

[Home](#) > [ar.cn.de.en.es.fr.id.it.ph.po.ru.sw](#)

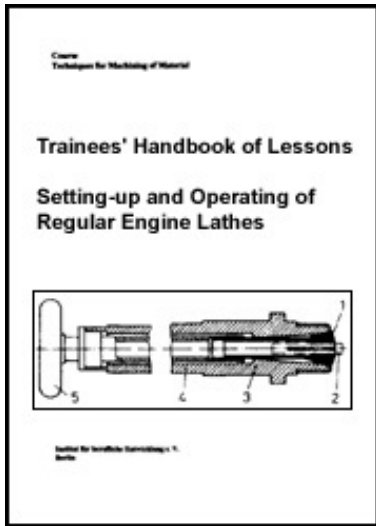

➔ **Setting-up and Operating of Regular Engine Lathes - Course: Techniques for machining of material. Trainees' handbook of lessons (Institut für Berufliche Entwicklung, 35 p.)**

(introduction...)

- 1. Importance of the regular engine lathe**
- 2. Structure of the regular engine lathe**
- 3. Structure and types of lathe tools**
- 4. Preparation of the work on the regular engine lathe**
- 5. Setting-up and operating the regular engine lathe**
- 6. Maintenance and care of the regular engine lathe**



[Home](#) > [ar.cn.de.en.es.fr.id.it.ph.po.ru.sw](#)

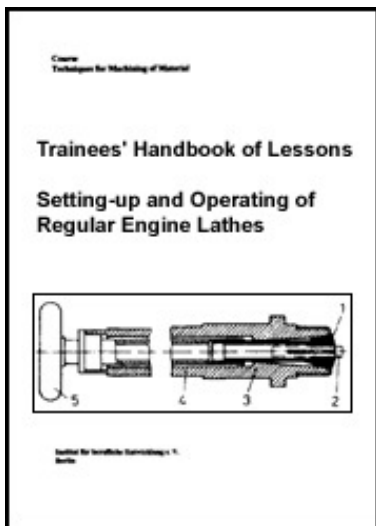

➔ **Setting-up and Operating of Regular Engine Lathes - Course: Techniques for machining of material. Trainees' handbook of lessons (Institut für Berufliche Entwicklung, 35 p.)**

(introduction...)

- 1. Importance of the regular engine lathe**
- 2. Structure of the regular engine lathe**
- 3. Structure and types of lathe tools**
- 4. Preparation of the work on the regular engine lathe**
- 5. Setting-up and operating the regular engine lathe**

 **6. Maintenance and care of the regular engine lathe**

**Institut für berufliche Entwicklung e.V.
Berlin**

**Original title:
Arbeitsmaterial für den Lernenden
"Einrichten und Bedienen von Leit- und Zugspindeldrehmaschinen"**

Author: Horst Kth

First edition © IBE

**Institut für berufliche Entwicklung e.V.
Parkstraße 23
13187 Berlin**

Order No.: 90-35-3201/2



[Home](#) > [ar](#).[cn](#).[de](#).[en](#).[es](#).[fr](#).[id](#).[it](#).[ph](#).[po](#).[ru](#).[sw](#)

 **Setting-up and Operating of Regular Engine Lathes - Course:
Techniques for machining of material. Trainees' handbook of
lessons (Institut für Berufliche Entwicklung, 35 p.)**

 **(introduction...)**

  **1. Importance of the regular engine lathe**



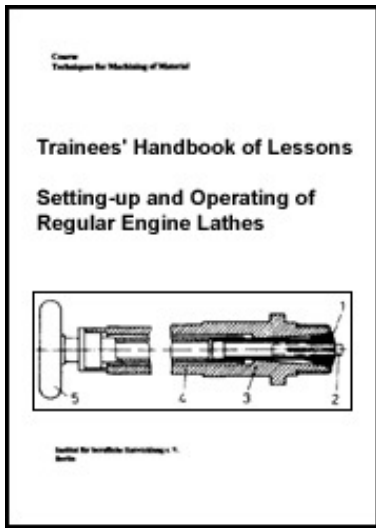

- 3. Structure and types of lathe tools
- 4. Preparation of the work on the regular engine lathe
- 5. Setting-up and operating the regular engine lathe
- 6. Maintenance and care of the regular engine lathe

1. Importance of the regular engine lathe

The regular engine lathe is a machine tool which gives a workpiece the desired shape, dimensions and surface quality by chip removal. Creating a movement between tool and workpiece, it places the tool on the point from which the chip has to be removed. The chip removal is carried out mainly by single-edged, permanently acting tools and serves to manufacture rotationally symmetrical workpieces required for high-standard machines and plants.

By the regular engine lathe work can be carried out such as:

- Centring by centring drill or single-point boring tool
- Plane turning
- Surfacing
- Boring by twist drill or single-point boring tool
- Counterboring
- Reaming

- **Recessing, cutting-out and parting-off**
- **Thread cutting by die, tap, etc., lathe tool (internal and external)**
- **Form turning**
- **Knurling and knurling straight-lined patterns**

with the aim to manufacture workpieces true to size and of the required shape and surface quality.

Primary materials for turning are products of the rolling industry, forgings, pressed parts and castings.



[Home](#) > [ar](#).[cn](#).[de](#).[en](#).[es](#).[fr](#).[id](#).[it](#).[ph](#).[po](#).[ru](#).[sw](#)

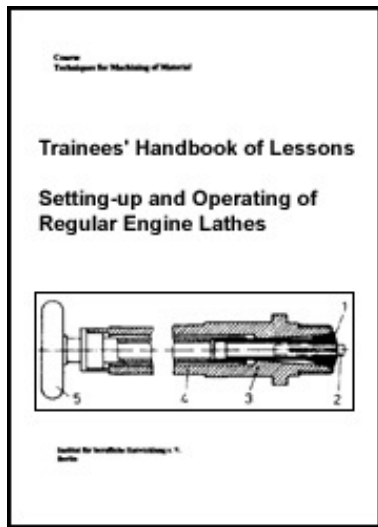

 **Setting-up and Operating of Regular Engine Lathes - Course: Techniques for machining of material. Trainees' handbook of lessons (Institut fr Berufliche Entwicklung, 35 p.)**

 **(introduction...)**

 **1. Importance of the regular engine lathe**

 **➔ 2. Structure of the regular engine lathe**

 **3. Structure and types of lathe tools**

 **4. Preparation of the work on the regular engine lathe**

 **5. Setting-up and operating the regular engine lathe**

 **6. Maintenance and care of the regular engine lathe**

2. Structure of the regular engine lathe

What main parts does a leadscrew and feed shaft lathe consist of?

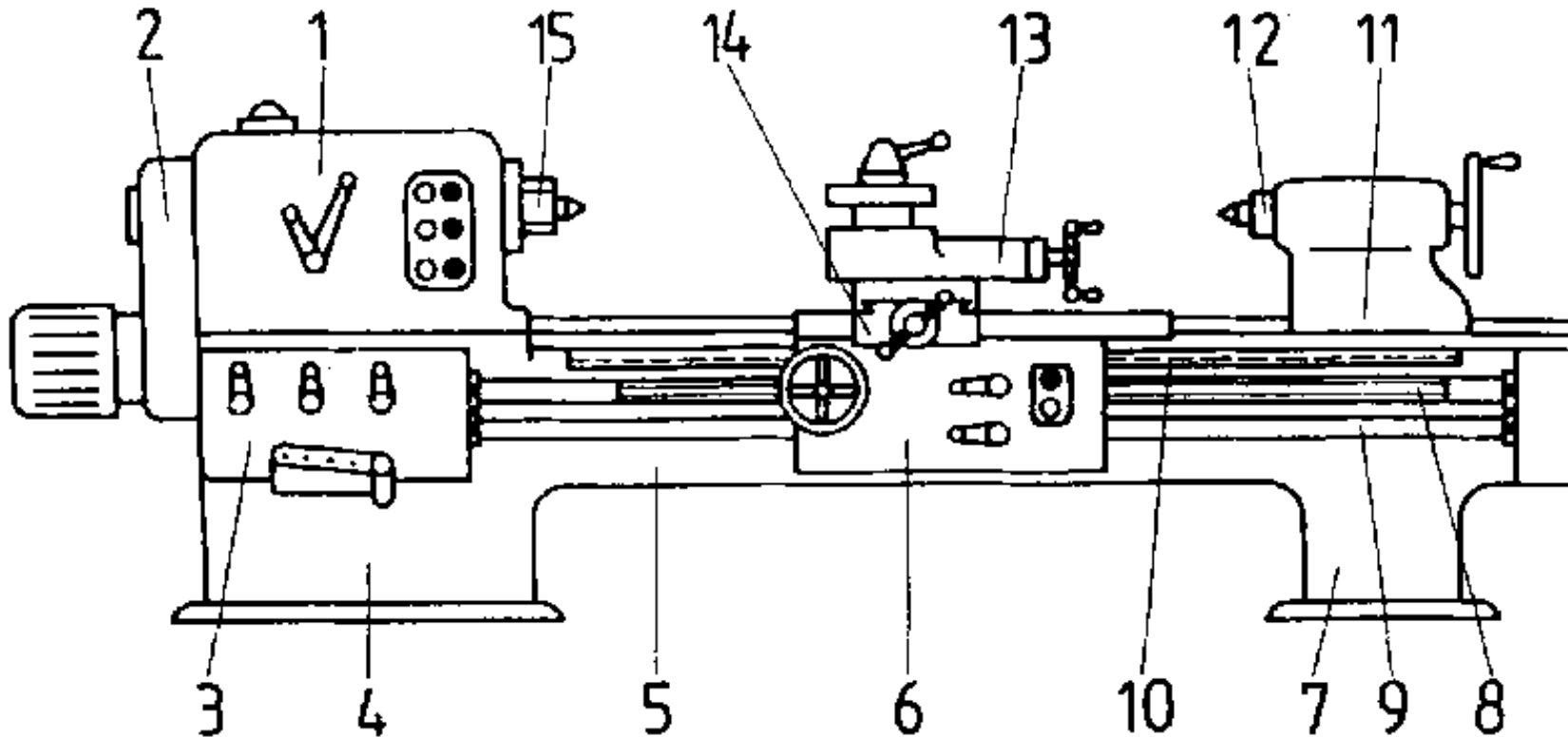

Figure 1. Regular engine lathe

1. _____

2. Train of pulleys

3. Feeding mechanism

4. _____

5. _____

6. _____

7. _____

8. _____

9. _____

10. _____

11. _____

12. **Quill**

13. _____

14. _____

15. **Work-driving spindle**

Regular engine lathes consist of various components which have to fulfill specific tasks, and the accurate functioning of which is a precondition of the handling of the operating elements.

The following components are distinguished:

- Lathe bed

- **Gear box**
- **Apron**
- **Tailstock**
- **Leadscrew and feed shaft lathe**

The faultless cooperation of the individual components and the correct operation of the lathe lead to the manufacture of workpieces of a high standard and the required accuracy.

Lathe bed

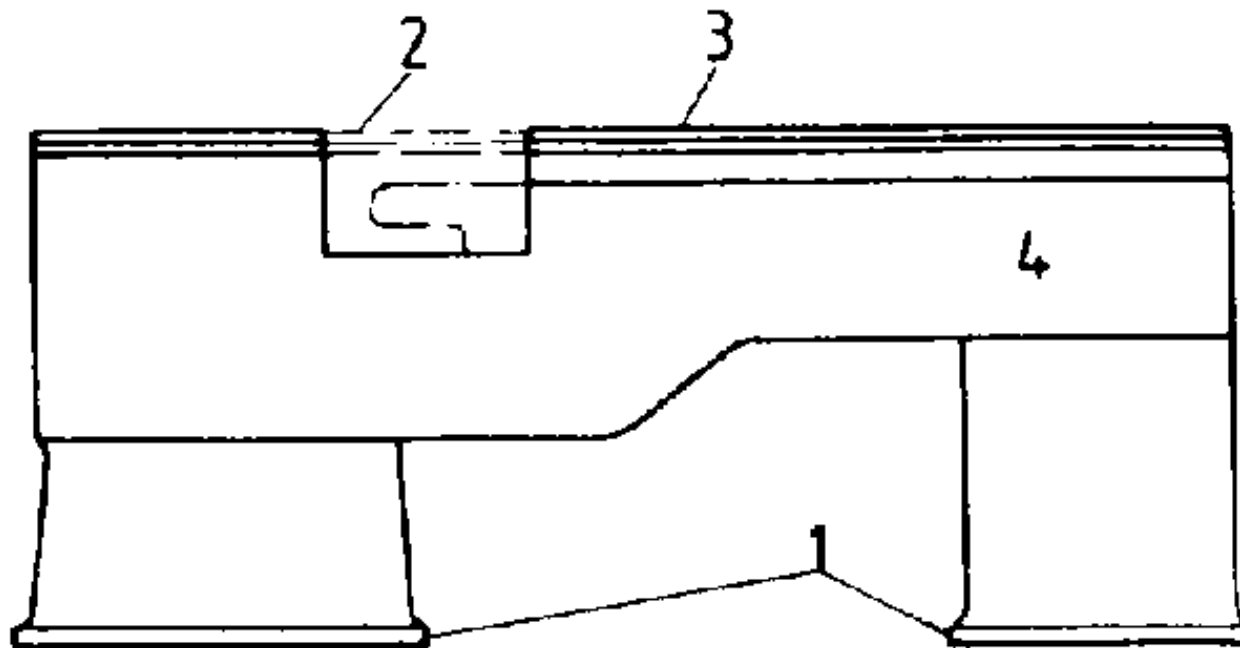

Figure 2. Lathe bed

1 lathe feet, 2 bridge, 3 guideways, 4 lathe bed

The lathe bed carries the spindle box with the work-driving spindle and the main

driving mechanism, the carriage with apron, saddle, cross slide, tool rest and lathe tool holder as well as tailstock with quill.

The apron and the tailstock are movable and are led on the lathe bed. In order to avoid shocks and vibrations as far as possible, the lathe bed is of a rigid construction.

Mostly, grey cast iron is used as material for the lathe bed, because this material absorbs shocks and vibrations and the graphite components create good sliding qualities and keep the abrasion low. To enable the turning of larger workpieces, the swing diameters of which are greater than their nominal diameters, on the faceplate, some lathes are equipped with a bridge that can be removed.

Important parts of the lathe bed are the guideways, of which two basic kinds are distinguished - sliding and roller guideways.

The sliding guideways are characterized by simple manufacture, great strength and faultless localization of the groups to be led. Roller guideways have roll bodies, only little friction, but are complicated in manufacture, have a low stressability and, when worn, become useless due to backlash.

Therefore, sliding guideways are used preferably.

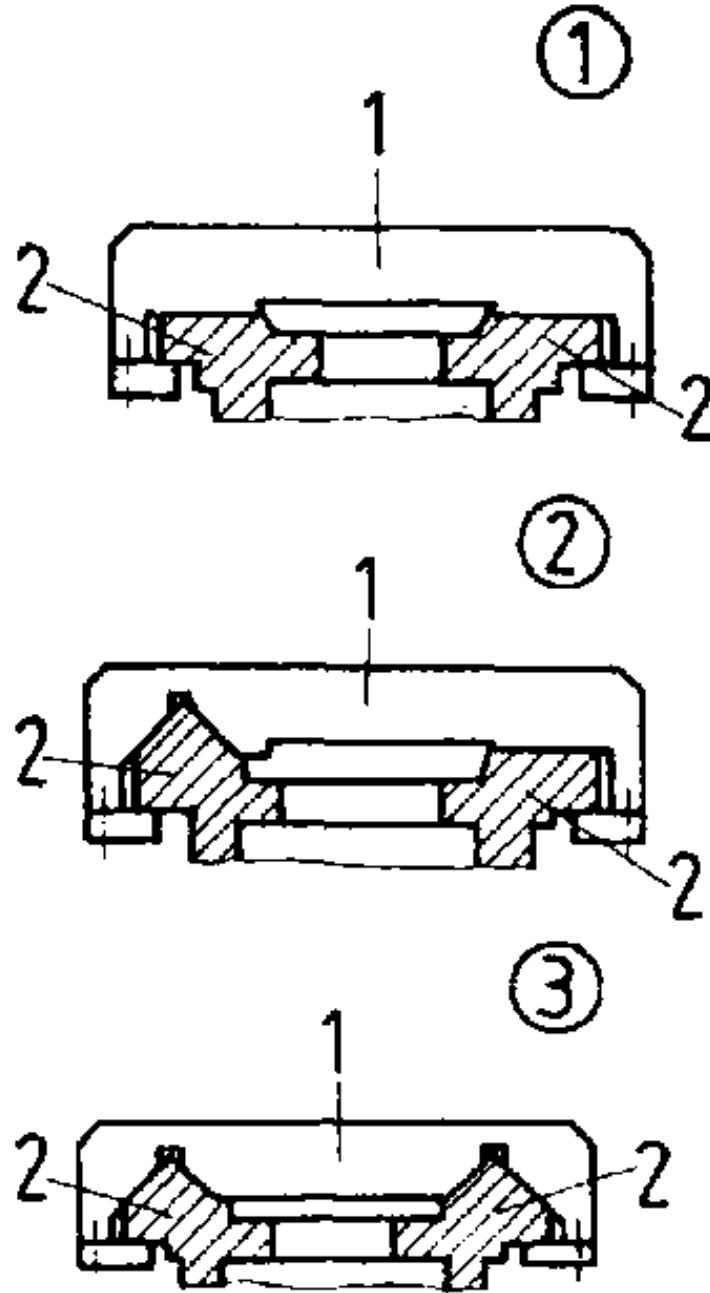

Figure 3. Slide

① flat track, ② combination of roof guide and flat track, ③ double roof guide
 1 saddle, 2 slide of the lathe bed

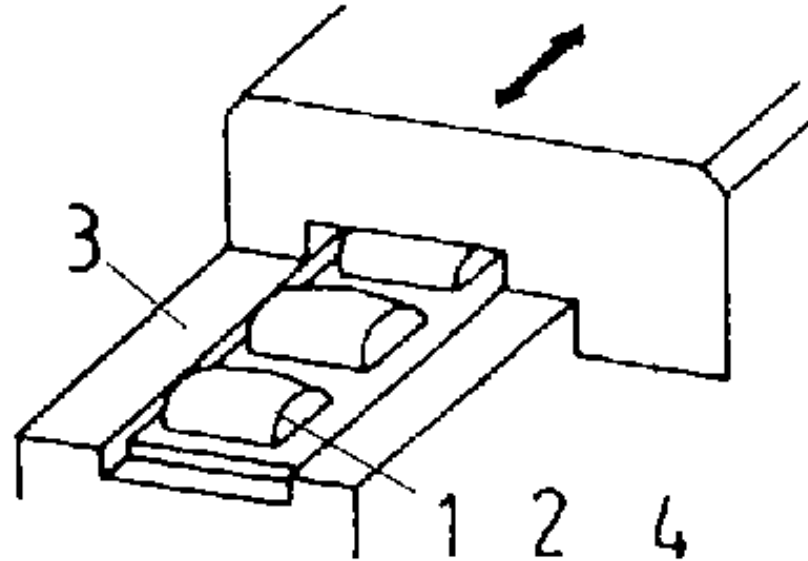

Figure 4. Roller guide

1 roll body, 2 cage, 3 lathe bed, 4 saddle

Why do some regular engine lathes have a bridge in the lathe bed and what purpose does it serve?

What are advantages and disadvantages of sliding and roller guideways, respectively, and which kind of guideways is used preferably?

Gear box

The main parts of the gear box are the headstock with the work-driving spindle, the main driving mechanism with the drive shaft as well as the feeding mechanism and the change-gear train.

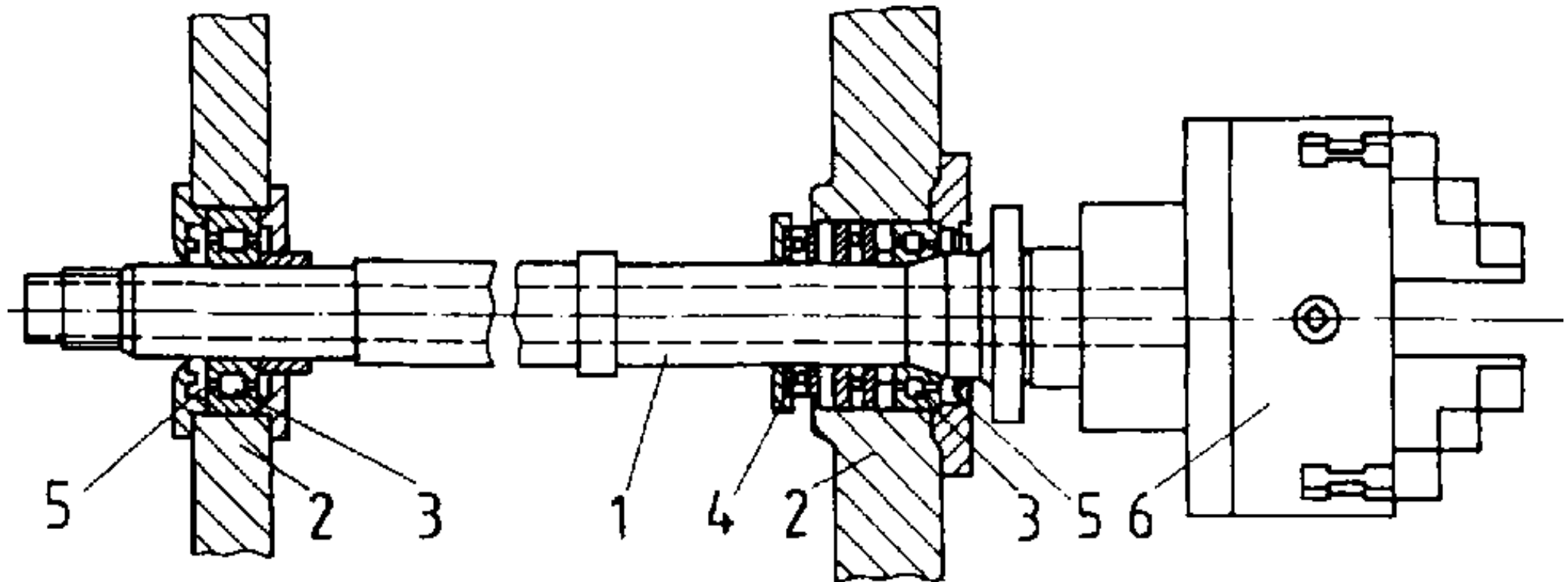

Figure 5. Work-driving spindle

1 work-driving spindle, 2 headstock casing, 3 radial roller bearing, 4 journal ball bearing, 5 packing, 6 chuck

In the headstock, the work-driving spindle is accommodated.

Mostly, the work-driving spindle is a hollow shaft, so that the material can be fed in, if required, (e.g. bar stock for the mass production of screws).

The end is equipped with an internal taper for receiving a centre and with an external thread for fixing the turning chuck, the faceplate, the work driver, etc. For radial stress, mostly cylindrical roller bearings, are used, for axial stress journal ball bearings.

The rotational speed of the spindle required for each respective operation is switched via the main driving mechanism. The main driving mechanism is designed either as a change-speed drive or as a stepless drive.

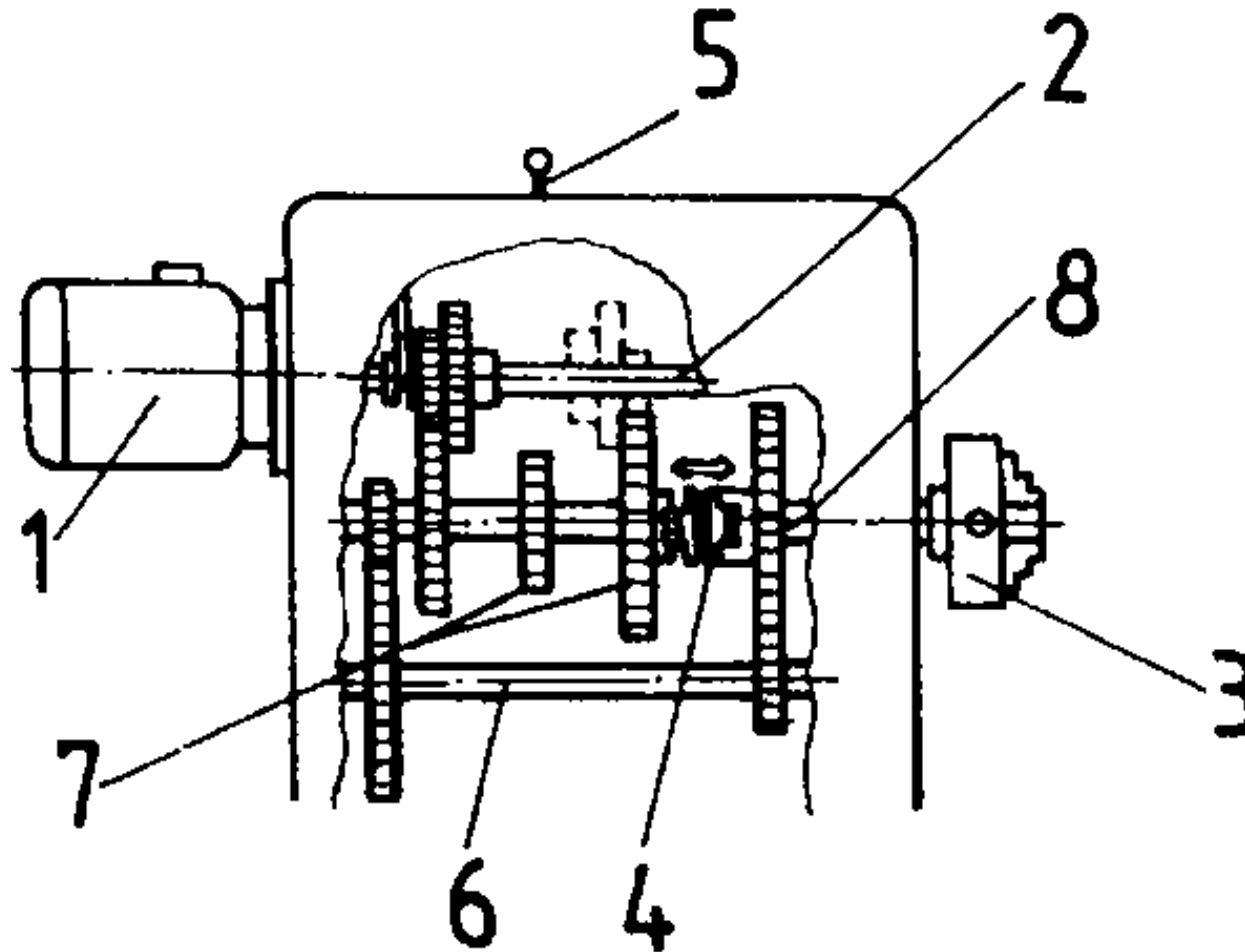

Figure 6. Main driving mechanism

1 driving motor (flange-mounte motor), 2 main shaft, 3 chuck, 4 coupling, 5 operating lever, 6 countershaft, 7 gears, 8 work-driving spindle

The power is transmitted from the motor via the toothed gears or the belt drive to the work-driving spindle (workpiece) or the feeding mechanism, respectively.

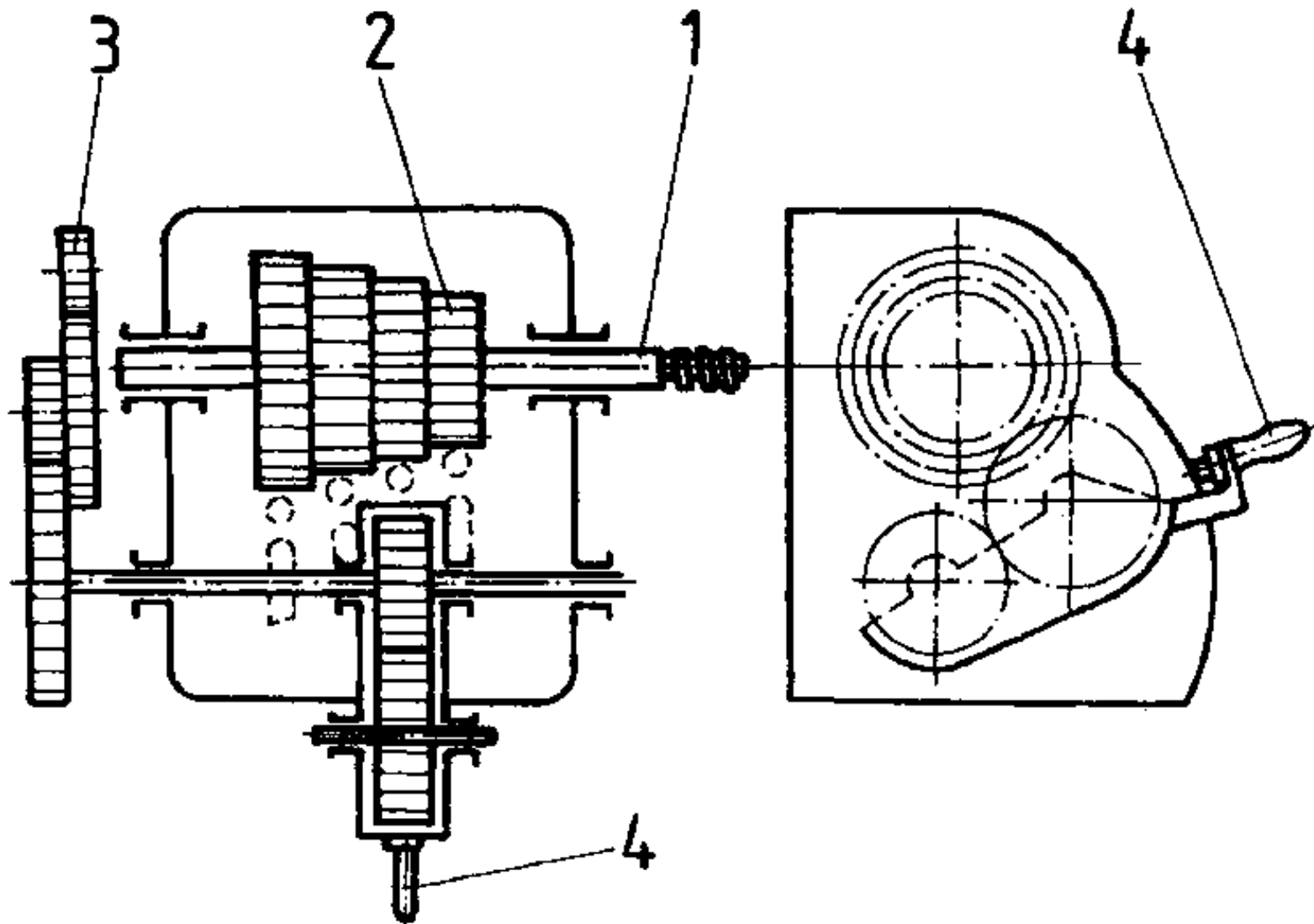

Figure 7. Feeding mechanism and change gear mechanism

1 leadscrew, 2 toothed gears, 3 change gear mechanism, 4 switching lever

By the feeding mechanism and the change-gear train the stepped feeding speeds are set, the thread cutting with different pitches is enabled, and the leadscrew and/or

feed shaft is driven.

What are the tasks of the feeding mechanism?

Describe the power train at a regular engine lathe.

1.

2.

3.

4.

5.

Carriage

On the carriage, the tools are fixed, put in working position and guided. The carriage slides on two prisms; it consists of the saddle, cross slide, swivel, tool rest and lathe tool holder.

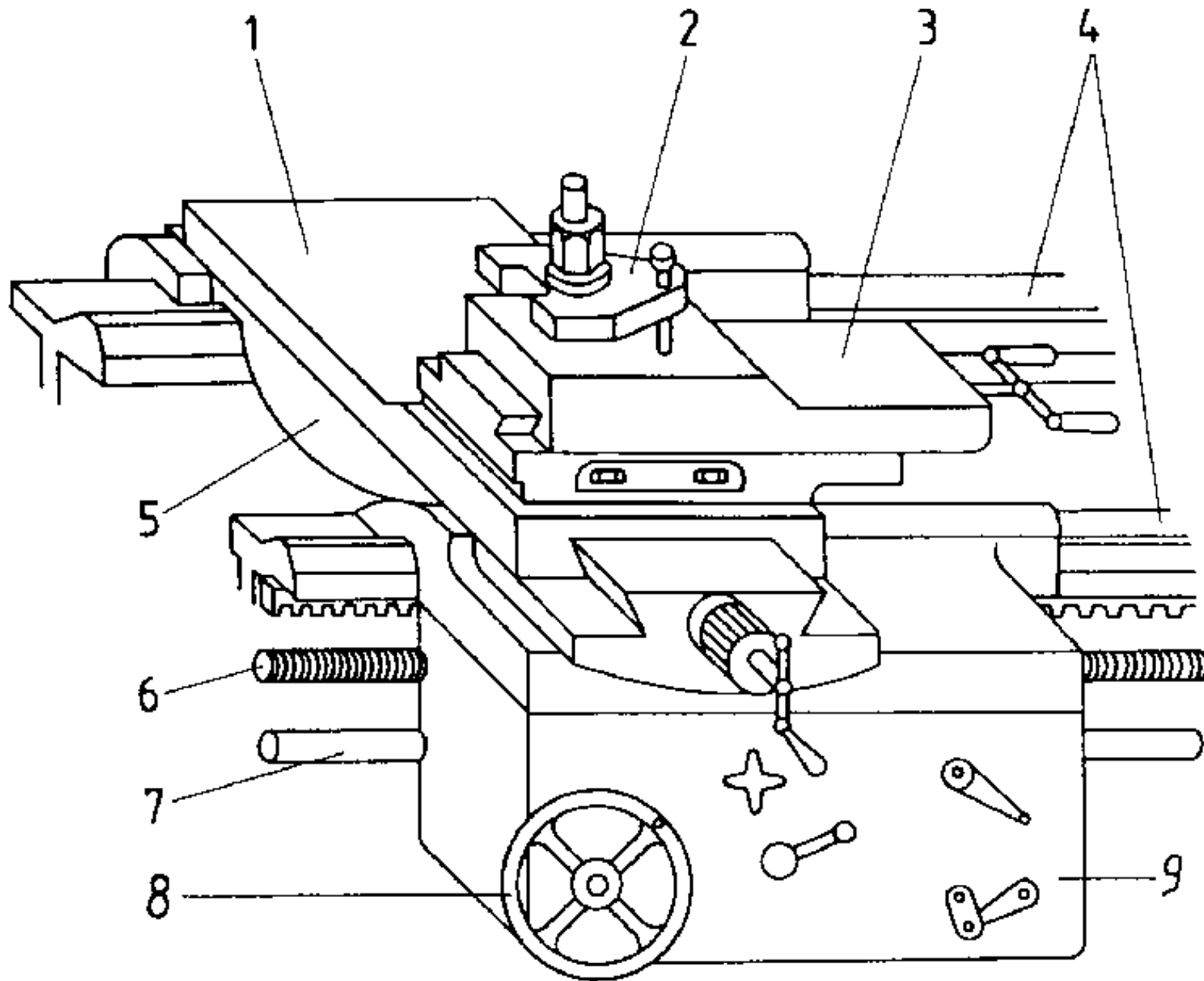

Figure 8. Carriage

1 cross slide, 2 lathe tool, holder, 3 tool rest, 4 guideways, 5 carriage, 6

leadscrew, 7 feed shaft, 8 hand wheel for longitudinal feed, 9 apron

The tool rest is pivoted on the cross slide and has a graduation in degrees for adjustment and/or taper turning. The compound rests slide in adjustable, dovetailed prismatic guideways.

The downfeed screws have ball cranks and large graduated disks for adjustment. The lathe tools are clamped in single or multiple-tool holders. The carriage is bolted to the lathe apron, which - due to its way of acting - belongs to the feed drive.

What are the tasks the carriage has to fulfill?

Tailstock

The tailstock is used as a counter-holding device for turning long workpieces or for drilling,

The tailstock is sliding on the guideways of the lathe bed and can be fixed in any place.

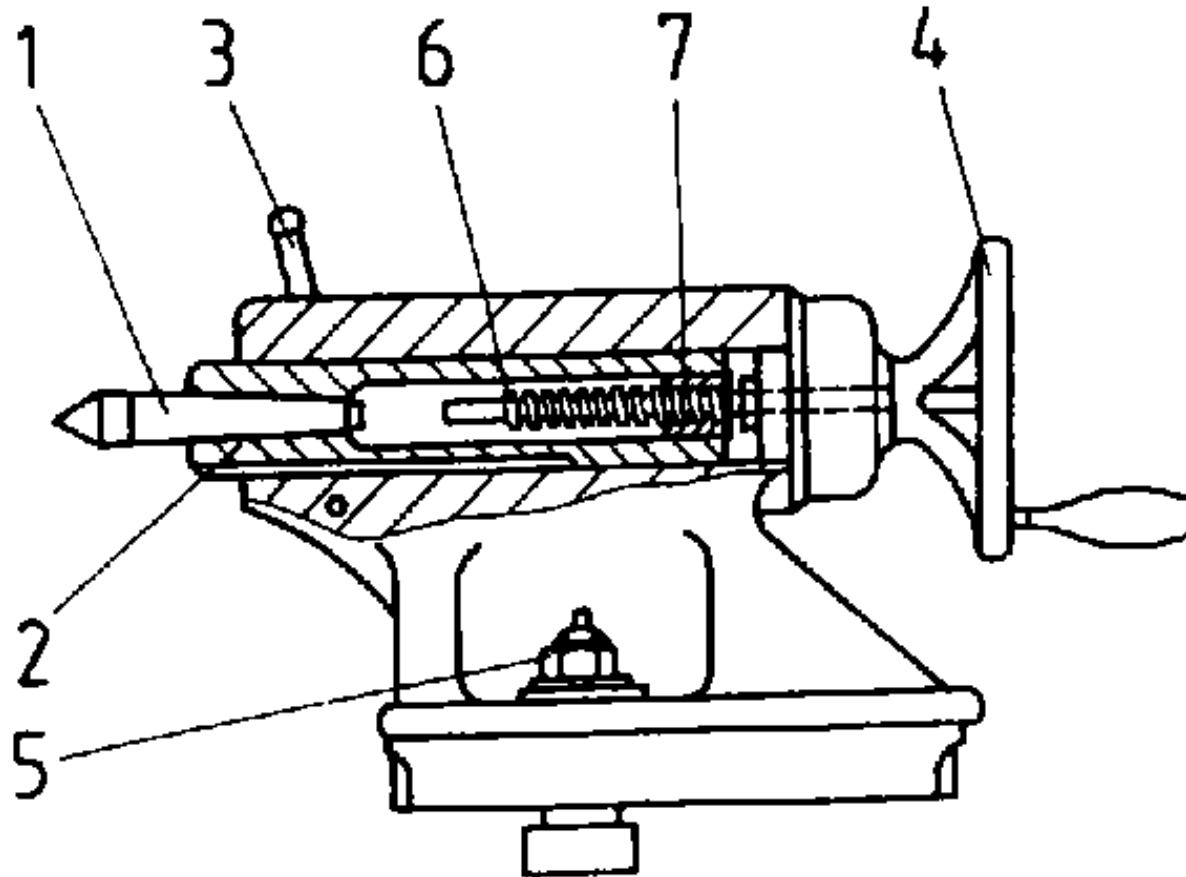

Figure 9. Tailstock

1 tailstock centre (replaceable), 2 quill, 3 clamping lever of the clamping nut, 4 hand wheel 5 tailstock clamping nut, 6 spindle, 7 spindle nut

When turning cylindrical workpieces, the centres of the headstock and of the tailstock must be exactly in line. By transverse displacement, it may also be used for turning slender tapers (loosening of the bridge, displacement of the tailstock on the bed plate by screws).

The quill is guided in a longitudinal boring. Its internal taper receives the centre of

the tailstock, the drill, the drill chuck or the reamer. The quill can be moved in its longitudinal direction for clamping the workpiece or for the drill feed. This can be made mechanically - through spindle and hand wheel or by levers - as well as hydraulically or pneumatically. By a clamping device the quill can be fixed in any position.

How can tapers be manufactured with the help of the tailstock and how must the tailstock be aligned for turning cylindrical workpieces?

Leadscrew and feed shaft

The leadscrew and feed shaft serve the purpose of thread cutting and/or automatic longitudinal and cross feed. The leadscrew is recognized by its acme thread, the feed shaft by its cylindrical shaft with longitudinal groove.

The power transmission of the leadscrew with thread cutting is effected by the closing of split nuts via toothed gears on the gear rack and from there on the carriage.

The feed is effected by the feed shaft the power being transmitted to the gear rack via a worm and toothed gears.

Describe the power train from the leadscrew and feed shaft to the carriage.



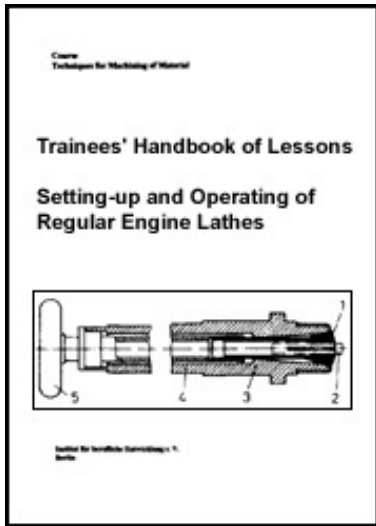

 **Setting-up and Operating of Regular Engine Lathes - Course: Techniques for machining of material. Trainees' handbook of lessons (Institut für Berufliche Entwicklung, 35 p.)**

 **(introduction...)**

 **1. Importance of the regular engine lathe**

 **2. Structure of the regular engine lathe**

 **3. Structure and types of lathe tools**

 **4. Preparation of the work on the regular engine lathe**

 **5. Setting-up and operating the regular engine lathe**

 **6. Maintenance and care of the regular engine lathe**

3. Structure and types of lathe tools

Knowledge of the lathe tools, their forms and application is the precondition of efficient working.

Structure of the lathe tool

Every lathe tool consists of the shank and the tool point. At the tool point, there are the top face and the flank. Shank and tool point may be made of the same material forming a whole.

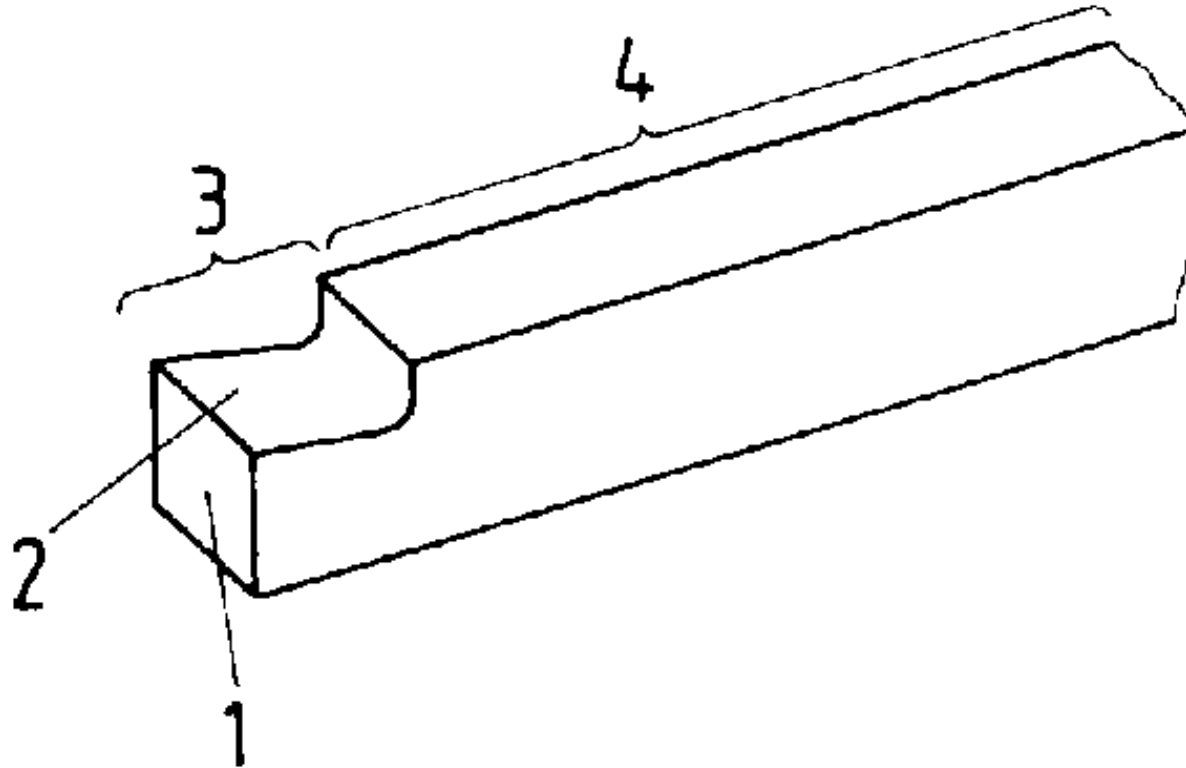
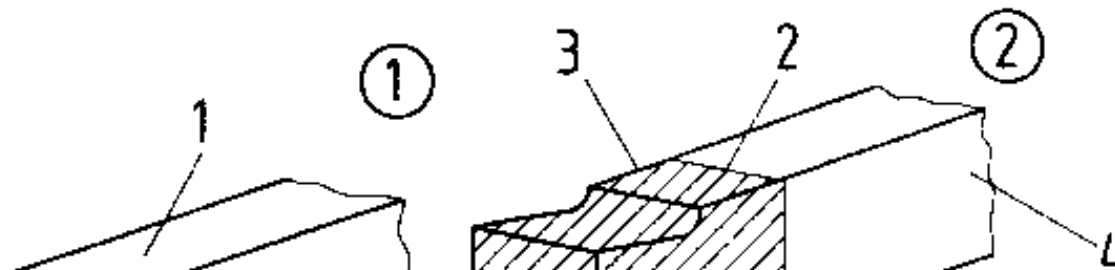
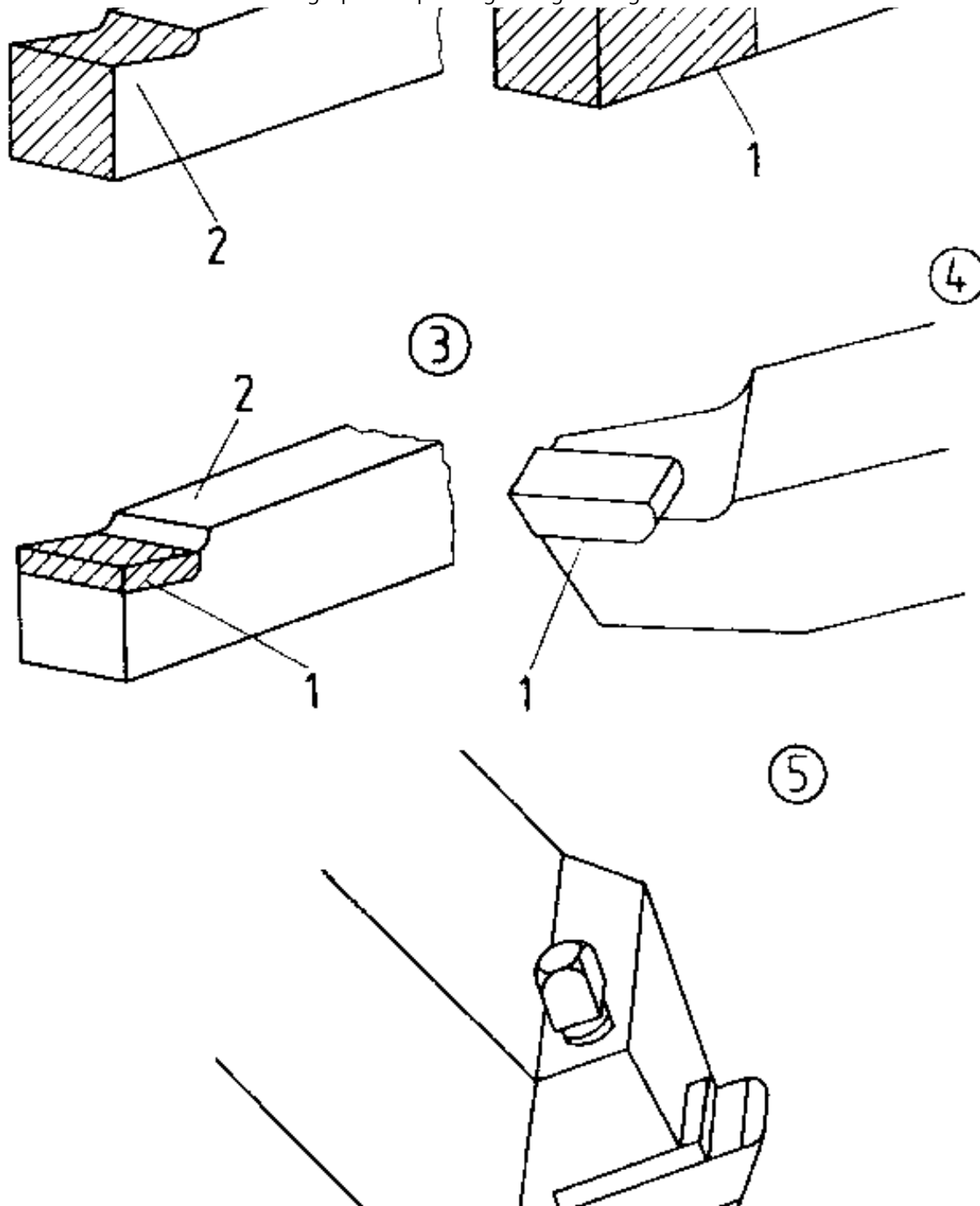

Figure 10. Structure of the lathe tool

1 flank, 2 cutting face, 3 tool point, 4 shank

In order to save valuable cutting material (high-speed steel) or because it is required by the qualities of other cutting materials such as hard metal, ceramic cutting materials, diamonds, the shank is often made from mild steel.





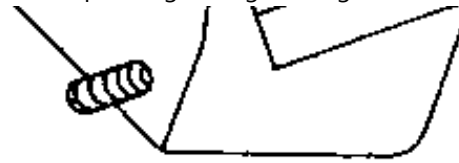

Figure 11. Lathe tool shank and cutting edge from solid steel or different materials

① lathe tool from solid steel

1 shank, 2 cutting head

② welded on (butt welded)

1 hardness threshold, 2 welding point, 3 high-speed steel, 4 mild steel

③ welded on

1 high-speed steel, 2 mild steel

④ welded on

1 soldering seam

⑤ seized

The cutting tip is welded or soldered or clamped in place in the form of a plate. The flank of the lathe tool is the surface of the tool point which is directed against the area of cut at the workpiece. The top face is the surface of the tool point over which the chip is removed.

Top face and flank must always be well and smoothly ground, so that no additional heat is created by friction during the turning process and a long service life of the tool is achieved.

Cutting edges at the lathe tool

The lathe tool has a primary cutting edge and a secondary cutting edge. The primary cutting edge faces the feed direction. The secondary cutting edge is adjacent to the primary cutting edge.

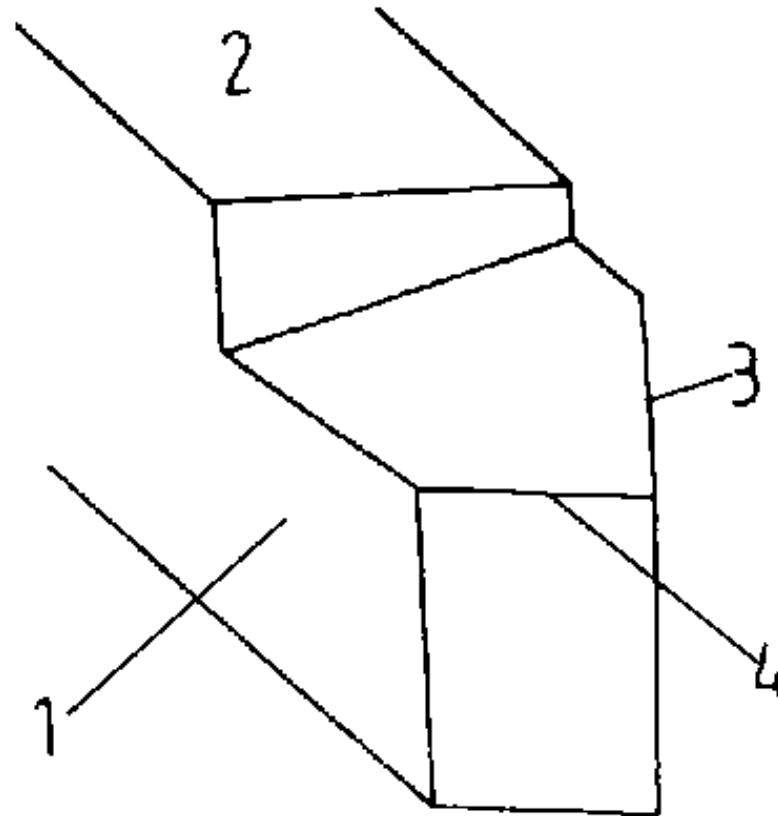

Figure 12. Cutting edges at the lathe tool

1 tool point, 2 shank, 3 main cutting edge 4 secondary cutting edge

Describe the structure of the lathe tools.

Angles at the lathe tool

Only if the cutting edges are ground correctly, the lathe tools can work economically. Therefore, one must know the correct angles at the cutting edge. The form of the cutting edge of the lathe tool is determined by the following angles:

α = angle of clearance

β = cutting-wedge angle

γ = rake angle

δ = cutting angle ($\alpha + \beta$)

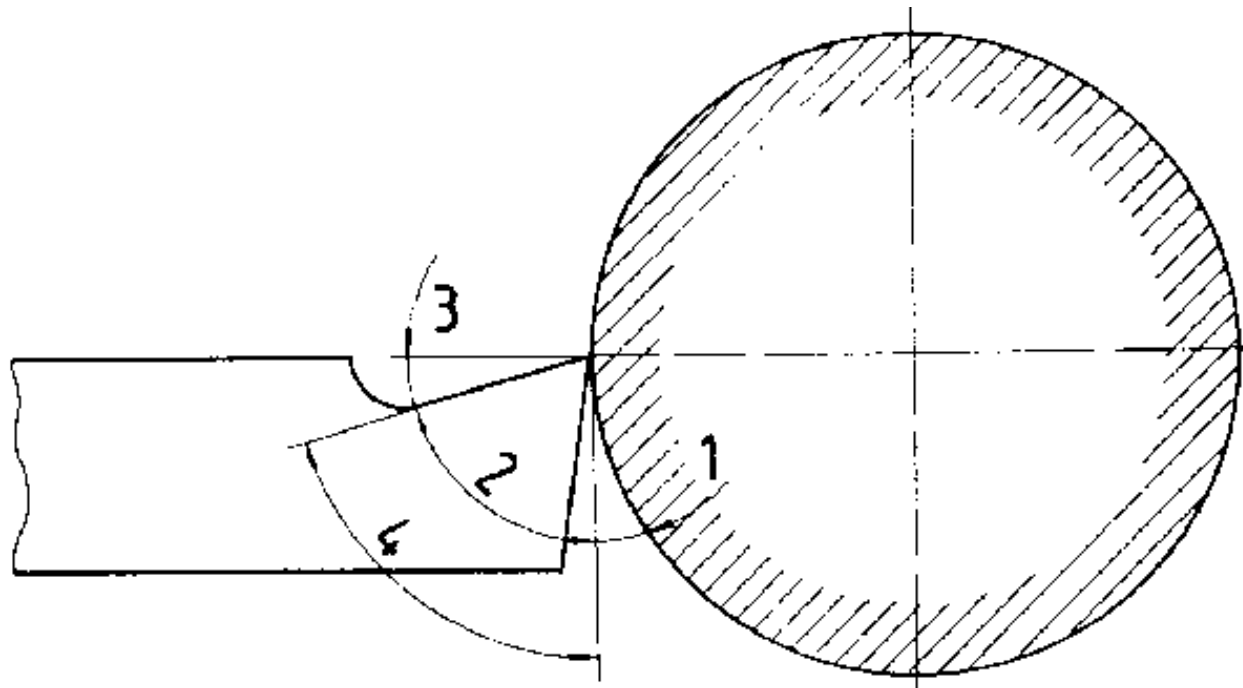

Figure 13. Angles at the lathe tool

1 angle of clearance α , 2 rake angle γ , 3 cutting-wedge angle β , 4 cutting angle δ

- **The cutting-wedge angle β is situated between flank and cutting face. It is measured in the normal (vertical) to the cutting edge. Its size is determined by the strength of the material to be worked.**

Hard materials require a large cutting-wedge angle, for instance steel: $\beta = 60 - 75^\circ$; soft materials require a small cutting-wedge angle, for instance aluminium: $\beta = 40^\circ$.

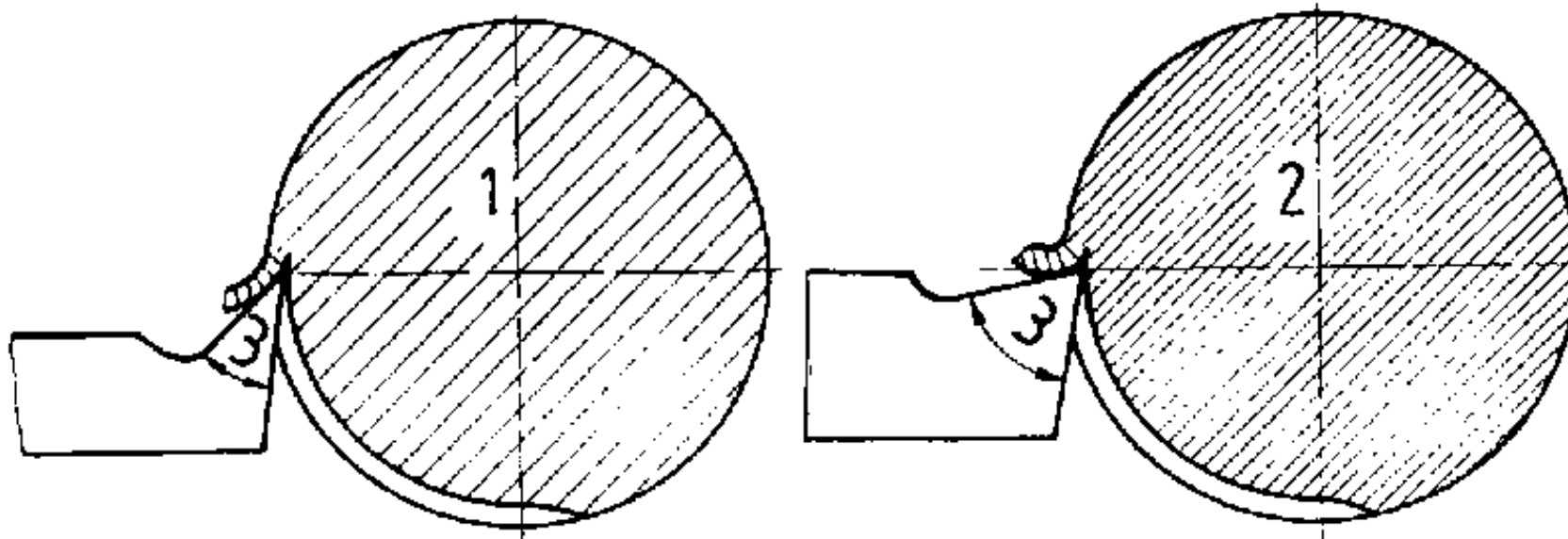

Figure 14. Lathe tool with small or large cutting-wedge angle

1 soft material - small cutting-wedge angle, 2 hard material - large cutting-wedge angle, 3 cutting-wedge angle β

- The angle of clearance α is determined by the flank and the tangent running through the points of contact of the cutting edge with the circumferential surface of the workpiece.

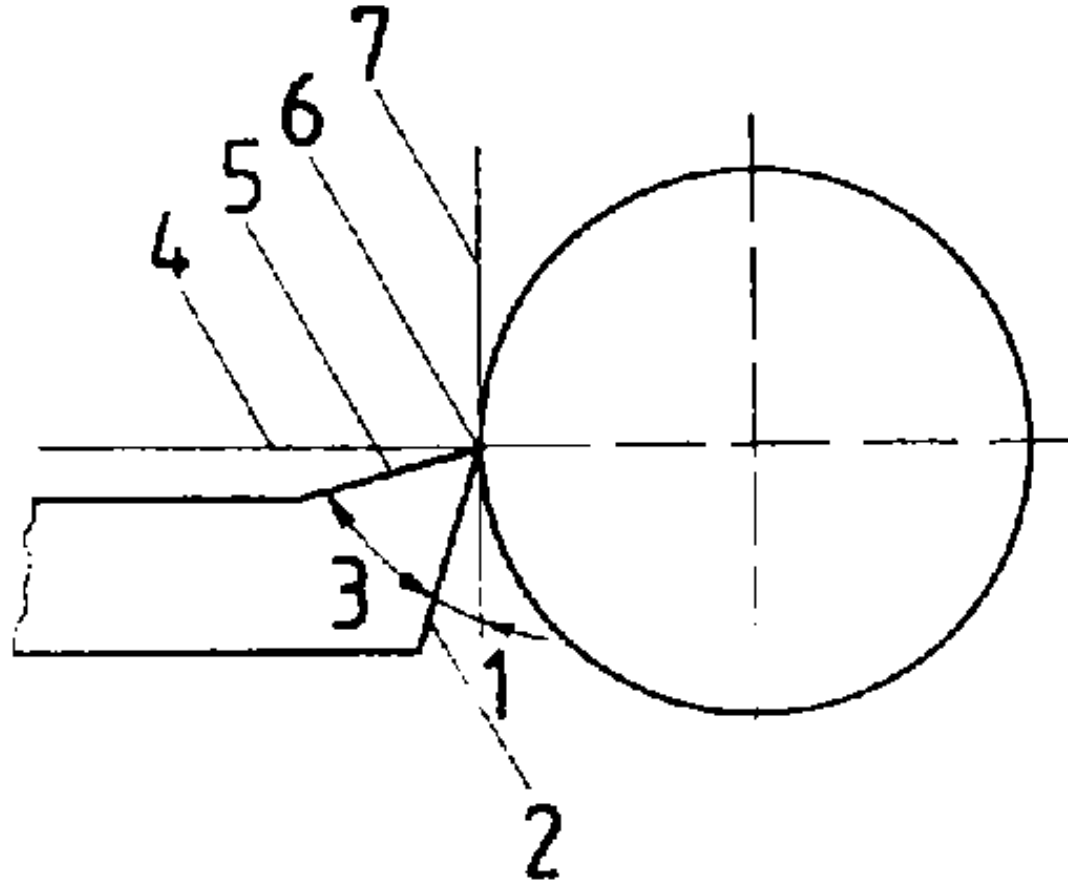

Figure 15. Position of the angle of clearance

1 angle of clearance α , 2 flank, 3 cutting-wedge angle β , 4 vertical, 5 top face, 6 point of contact, 7 tangent

The angle of clearance must always be chosen only that large so that there is not

too much friction between tool and work-piece.

- The rake angle γ is formed by the cutting face and the vertical drawn on the tangent in the point of contact. In principle, the rake angle should be kept large in order to enable an easy removal of the chips. However, the size of the rake angle is limited by the size of the cutting-wedge angle which depends on the material.

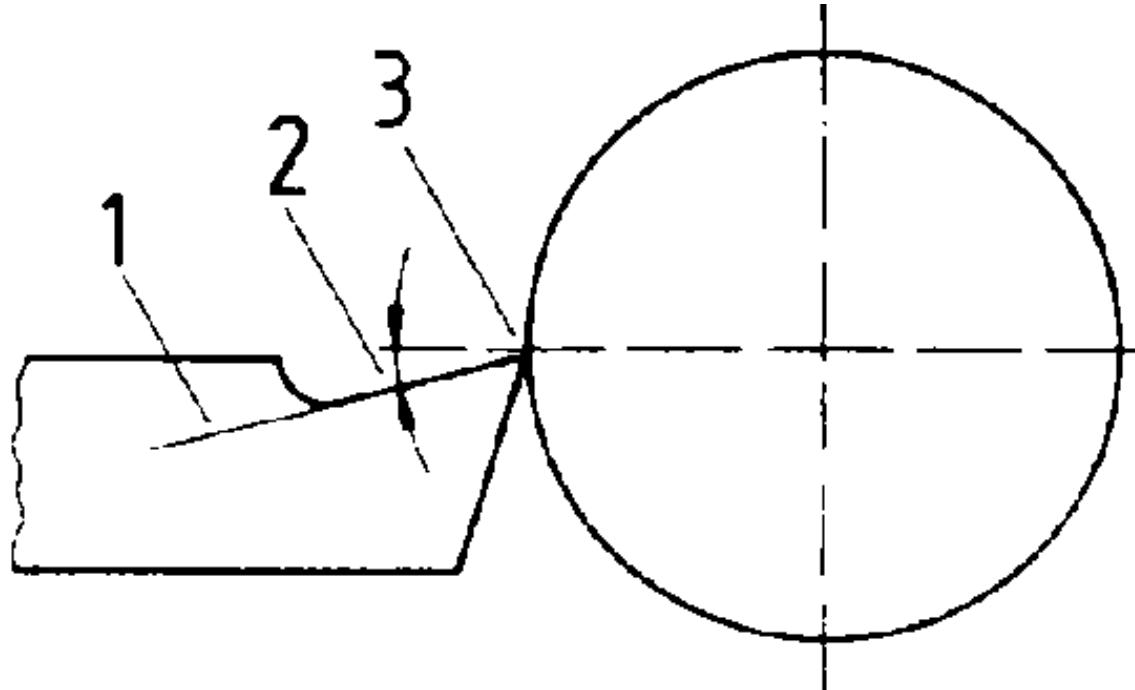

Figure 16. Position of the rake angle

1 top face, 2 rake angle γ , 3 vertical

- The cutting angle δ plays a secondary part only.

It is formed by the angle for clearance and the cutting-wedge angle ($\delta = \alpha + \beta$). It is situated between the cutting face and the vertical plane to the cutting edge.

Table 1 gives a general survey of the sizes of the angles at the lathe tool related to the cutting material "high-speed steel".

Why is it necessary to know the correct angles at the cutting edge of the tool?

Table 1

Material to be worked	Angle of clearance	Cutting-wedge angle	Rake angle¹⁾
	(indication of angles in °)		
Steel	8	62 - 68	14 - 20
Alloyed steel	8	68 - 74	8 - 14
Tool steel	8	72	10
Grey cast iron	8	80	2
Copper	10	55	25
Brass	8	74	8
Bronze	8	74	8
Aluminium	10	60	20

1) The angles apply to rigid cutting conditions. In semi-rigid conditions, only the rake angle has to be increased up to 15 %, with unstable conditions up to 25 % and with soft, smearing materials up to 30 % in order to achieve a good non-torn finish-machined surface.

Types of lathe tools:

The type of lathe tool to be used in each respective case is determined by the shape of the workpiece which has to be worked.

For longitudinal turning, roughing and finishing lathe tools are required, for turning internal surfaces such as corners side cutting turning tools, for plunging and cutting-off parting-off tools etc.

If much material has to be removed, the roughing tool has to be used first. If high demands are made on the surface quality of the workpiece, the finishing lathe tool has to be used. Each operation requires the corresponding lathe tool. It would be a waste of time and expensive material to permanently adapt one lathe tool - for instance a side cutting turning tool for all sorts of turning.

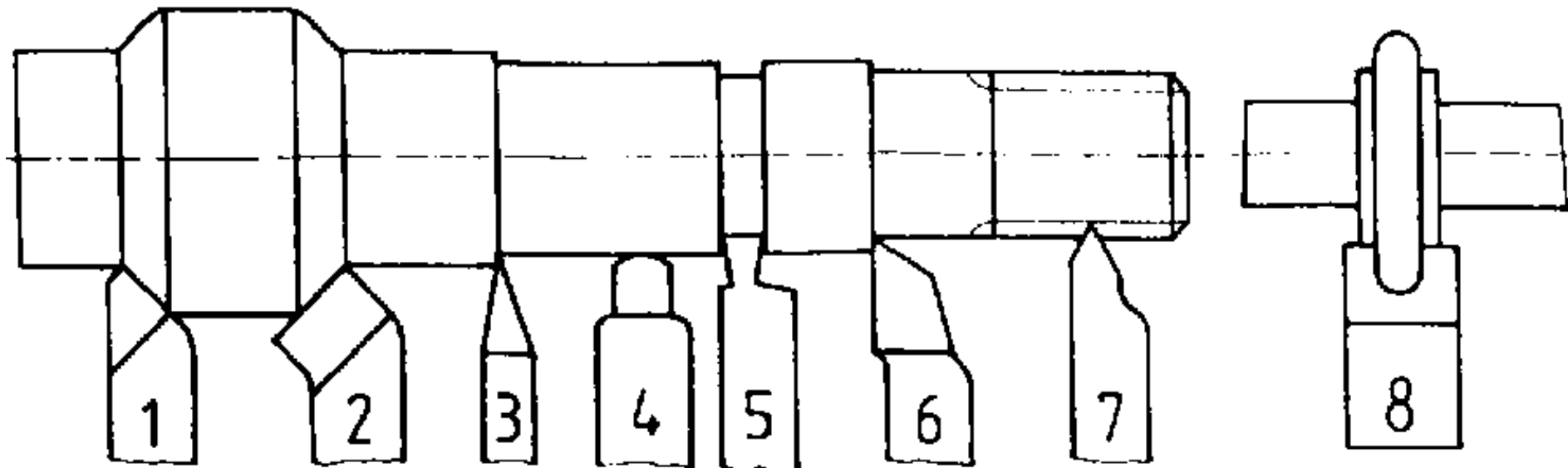

Figure 17. Tools for turning external diameters

1 straight left roughing lathe tool, 2 bent right roughing lathe tool, 3 straight finishing tool, 4 broad finishing tool, 5 straight right-end-cut turning tool, 6 offset side cutting turning tool, 7 vee thread cutting tool, 8 form turning tool

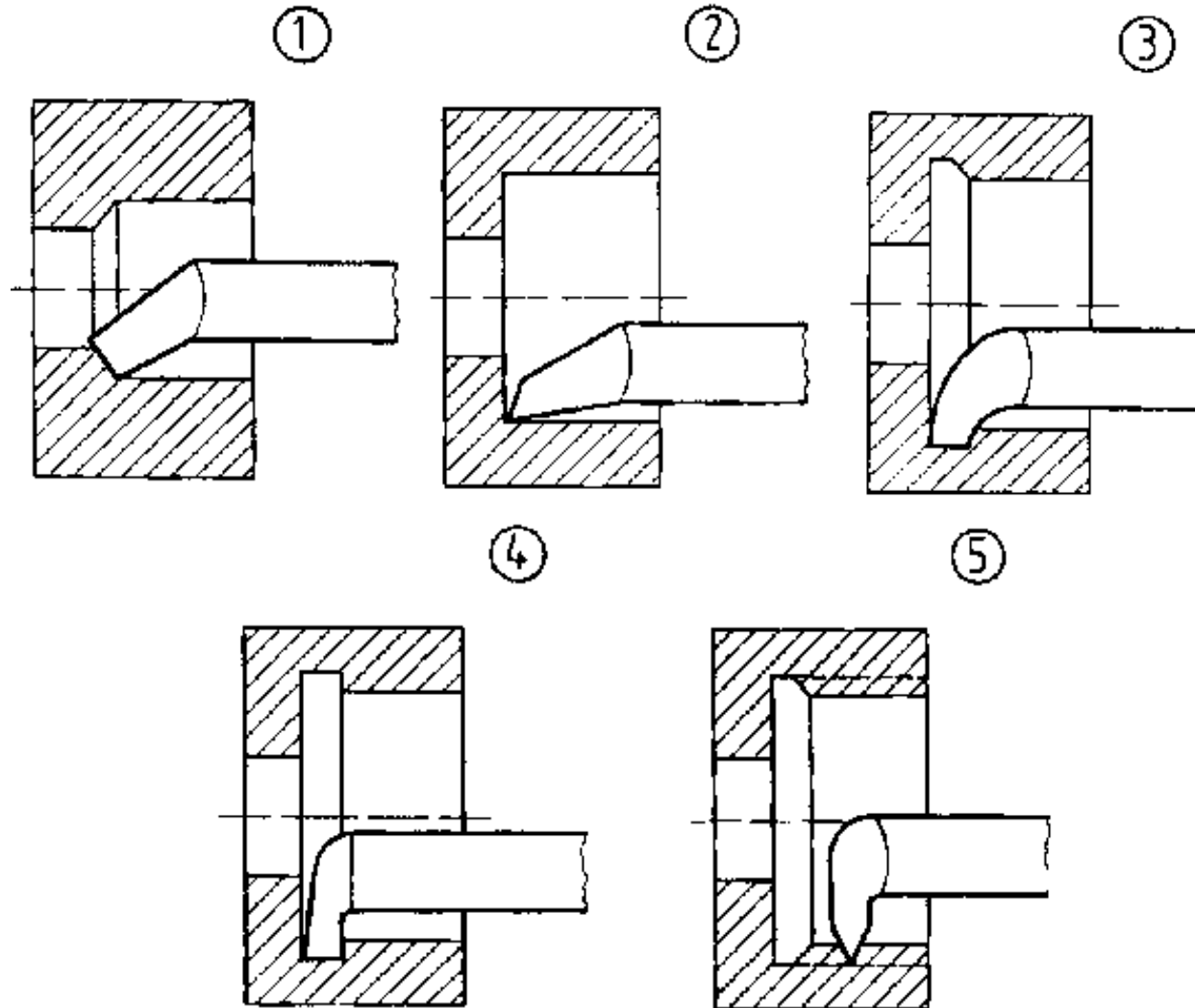

Figure 18. Internal turning tools

① single-point boring tool; ② internal side cutting turning tool; ③ thread

groove plunging tool; ④ right undercutting tool; ⑤ internal screw-cutting tool

The most important lathe tools are standardized as to their shapes and dimensions. As far as the designations of the angles and surfaces as well as of the various types of lathe tools are concerned, there are generally valid international arrangements, too.

Lathe tools for turning internal and external surfaces are generally distinguished as shown in the pictures. What does the use of the respective types of lathe tools depend on?



[Home](#) > [ar](#).[cn](#).[de](#).[en](#).[es](#).[fr](#).[id](#).[it](#).[ph](#).[po](#).[ru](#).[sw](#)

 **Setting-up and Operating of Regular Engine Lathes - Course: Techniques for machining of material. Trainees' handbook of lessons (Institut für Berufliche Entwicklung, 35 p.)**

 **(introduction...)**

 **1. Importance of the regular engine lathe**

 **2. Structure of the regular engine lathe**

 **3. Structure and types of lathe tools**

  **4. Preparation of the work on the regular engine lathe**

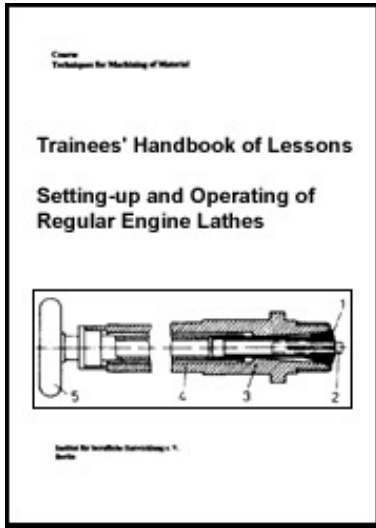

- 5. Setting-up and operating the regular engine lathe
- 6. Maintenance and care of the regular engine lathe

4. Preparation of the work on the regular engine lathe

Possibilities of tool clamping

Lathe tools must be firm and safely clamped. Insufficient clamping may lead to rejects or accidents. By the clamping claw or the lathe tool holder, the lathe tool is fixed well even with difficult cuts.

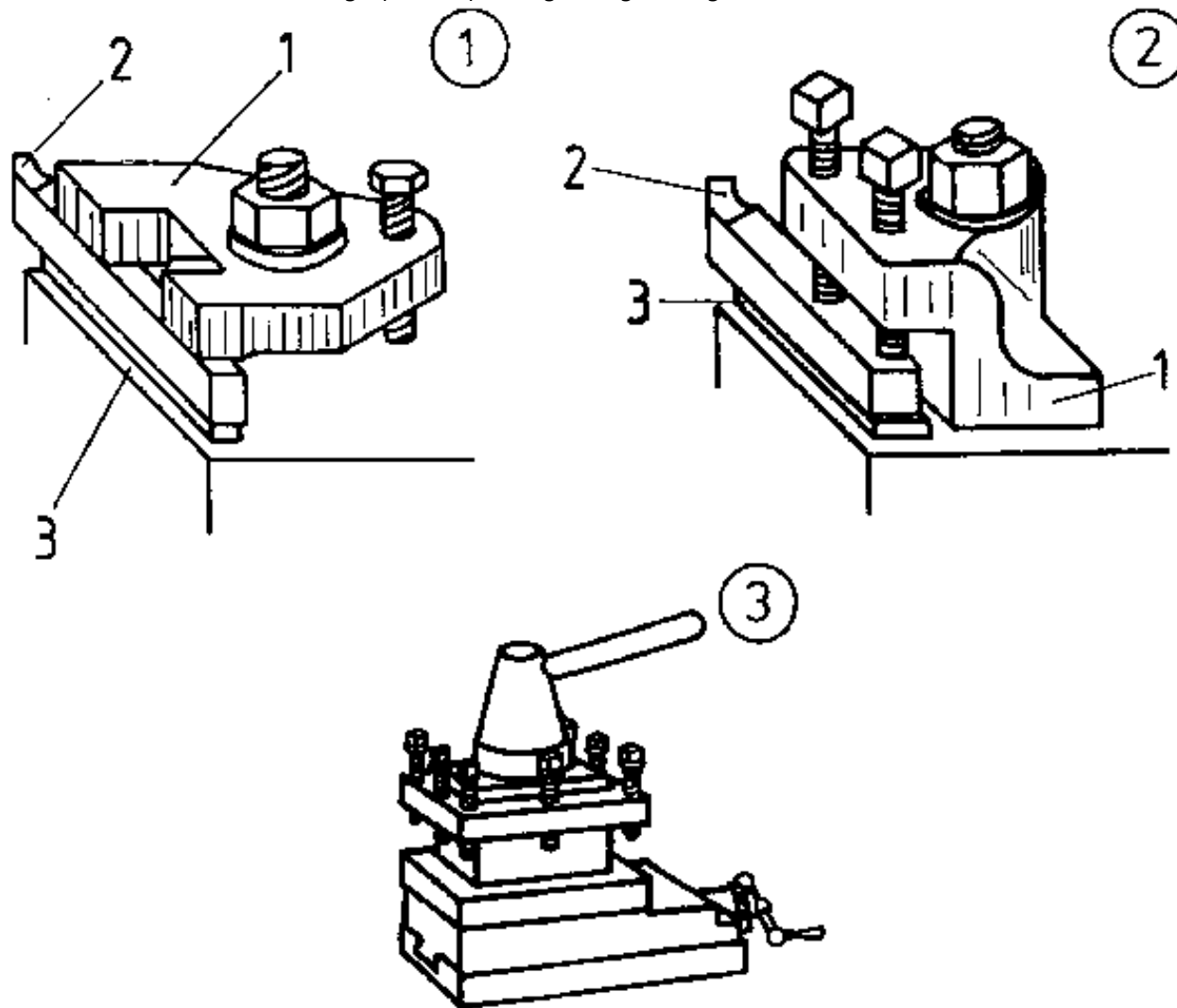

Figure 19. Clamping possibilities of the lathe tool

① clamping jaw; ② lathe tool holder; ③ rotatable fourfold lathe tool holder

With the help of the quadruple lathe tool holder, up to four lathe tools can be set up for the respective work.

Thus, the clamping and unclamping of the lathe tools and the work-pieces for the individual operations is no more necessary. As soon as a new workpiece shall be worked, the hand lever is unlocked, the tool holder is turned and the lever is tightened again with the exact position of the individual lathe tools being secured by an index.

Clamping must be firm and safe. Insufficient clamping may cause rejects, breaking of the lathe tools and accidents.

Pay attention to the following points:

- The lathe tool must always be in dead central position (centre of the tailstock/setting gauge).**
- Height adjustment by sheet metal backings (must be accurately plane and clean; use a few thick backings instead of many thin ones; the length should be at least three quarters of that of the tool shank).**
- Do not adjust the height by placing sheet metal under the rear end of the lathe tool.**
- Use of the quadruple lathe tool holder.**

The multiple-cutting edge boring tools are put by their taper shank into the machine taper of the tailstock spindle.

Then, they are advanced towards the workpiece which is rotating with the work-driving spindle with the help of the hand wheel.

If the external taper of the drill and the internal taper of the quill do not match, the difference - if the internal taper is larger - can be balanced by reducing sleeves.

External and internal tapers must be absolutely clean, otherwise the drill rotates in the quill and destroys the internal taper.

In addition, it would, in such case, not be at centre with the rotation axis.

Larger drills are protected against the above mentioned kind of rotation by putting on a work driver.

Small drills are clamped in the drill chuck, which, then, is put into the quill by its taper shank.

In some cases, the automatic feed is used for moving the boring tool forward. For this purpose, the drill is clamped on the carriage with the help of a holding device.

Drill axis and rotation axis must be accurately congruent.

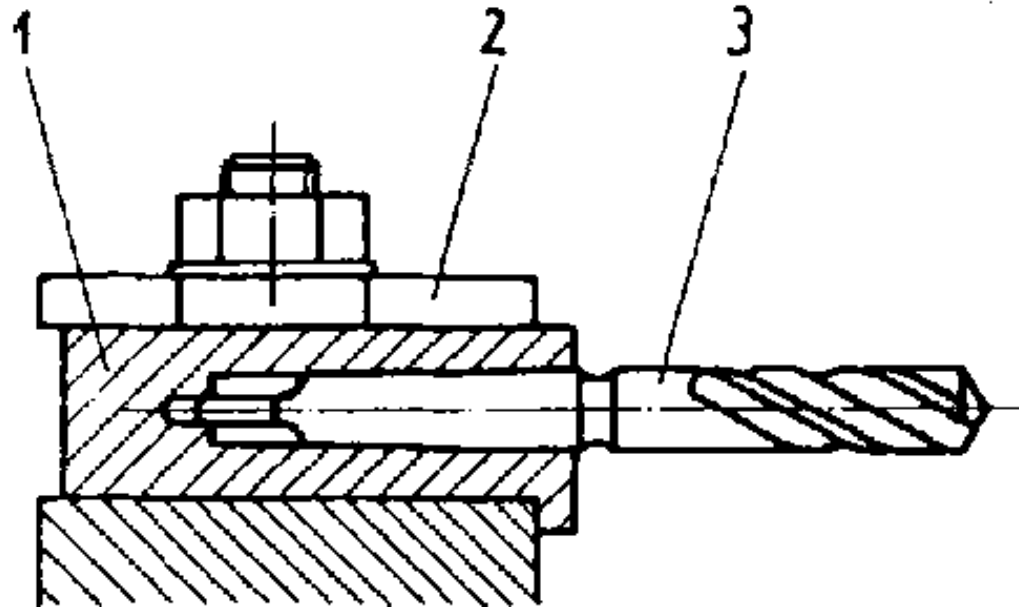

Figure 20. Boring block

1 boring block, 2 lathe tool holder, 3 twist drill

Possibilities of clamping the workpieces

The three-jaw chuck serves for clamping short workpieces quickly, safely and centrally.

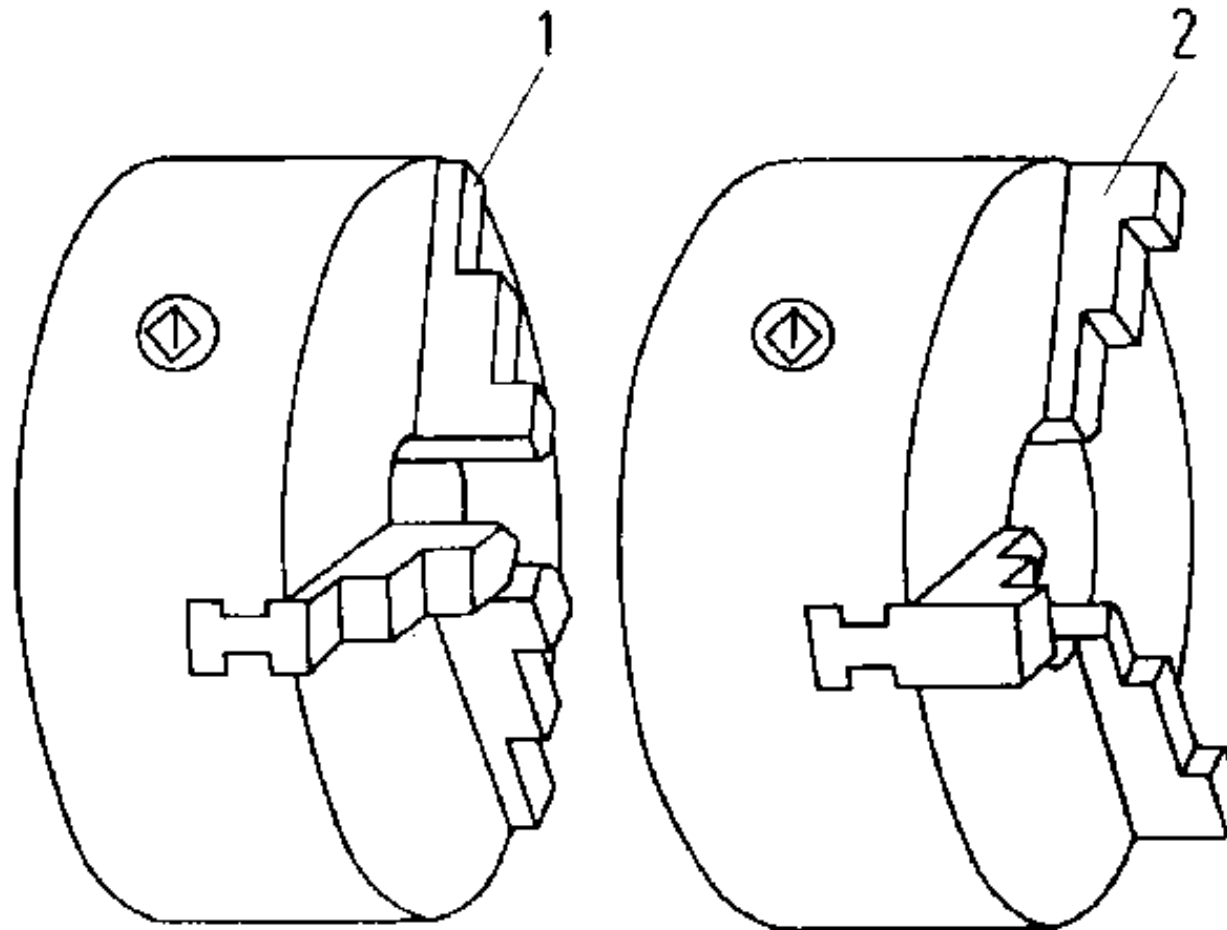

Figure 21. Three-jaw chuck

1 three-jaw chuck with turning jaws, 2 three-jaw chuck with boring jaws

With the help of the four-jaw chuck, quadrangular and octagonal parts are clamped.

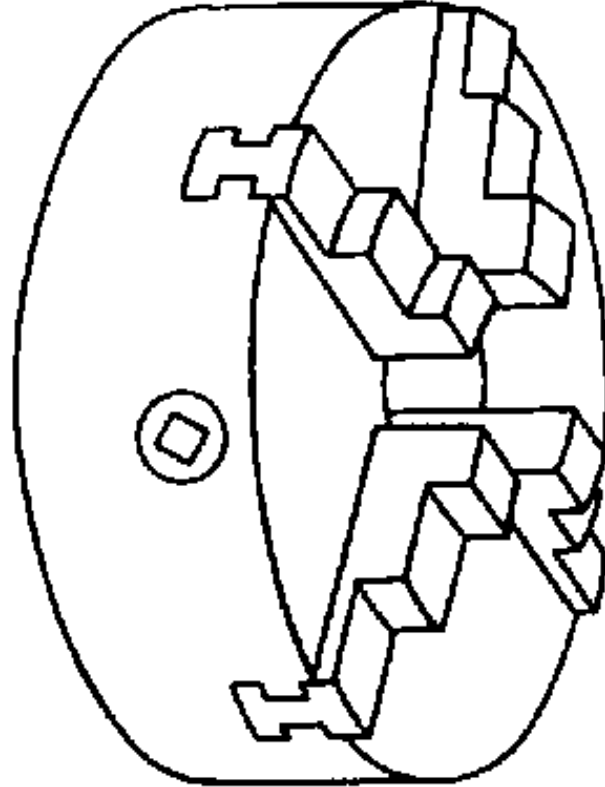

Figure 22. Four-jaw chuck

In order to achieve an exact true running of the parts, soft gripping jaws are used which are bored true to size of the respective workpieces.

Small, irregularly shaped workpieces are often clamped in the four-jaw chuck with individually adjustable chuck jaws.

They can be quickly aligned. The chuck jaws can be moved in common as well as individually,

For clamping smaller workpieces and for working from the bar, especially on turret lathes and automatics, the collet chuck is used.

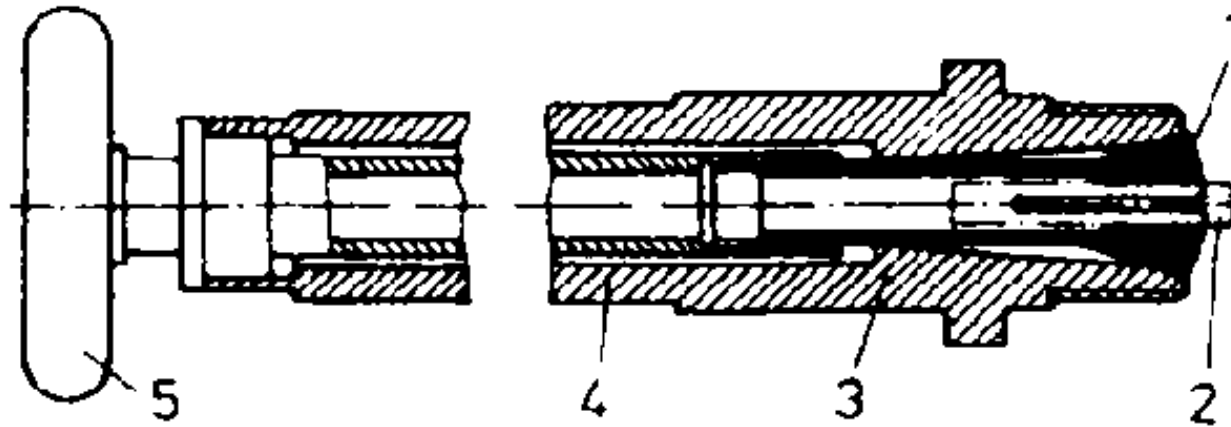
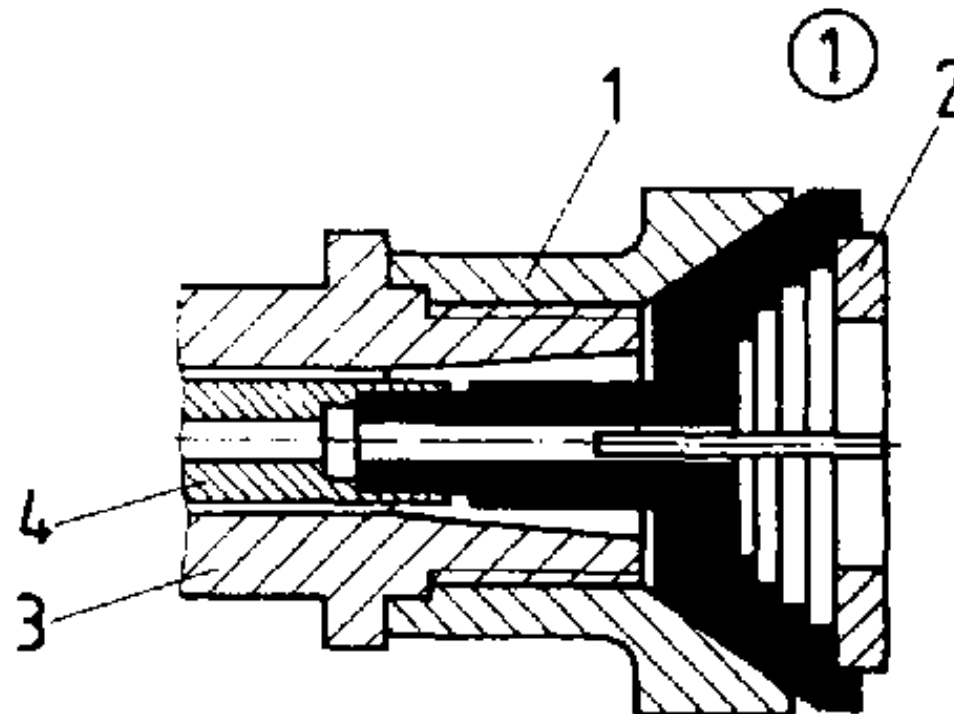

Figure 23. Collet

1 clamping body, 2 workpiece, 3 lathe spindle, 4 clamping tube, 5 handwheel



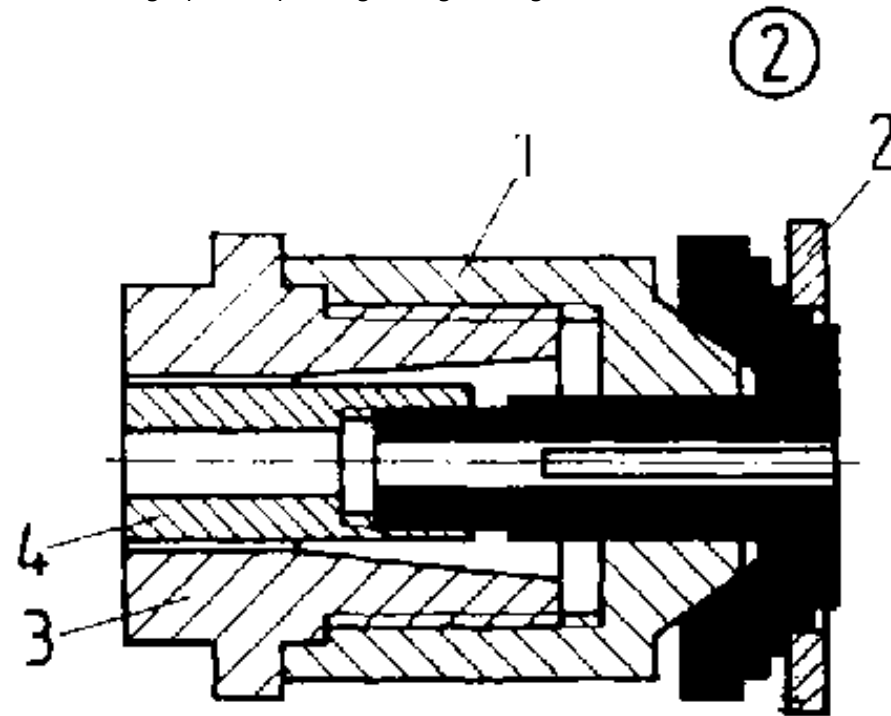

Figure 24. Step chuck

① internal step chuck; ② external step chuck

1 basic chuck, 2 workpiece, 3 lathe spindle, 4 clamping tube

Large, flat bodies of revolution such as disks and lids but also square and rectangular as well as irregularly shaped workpieces are - nearly without exception - are clamped flying on faceplates.

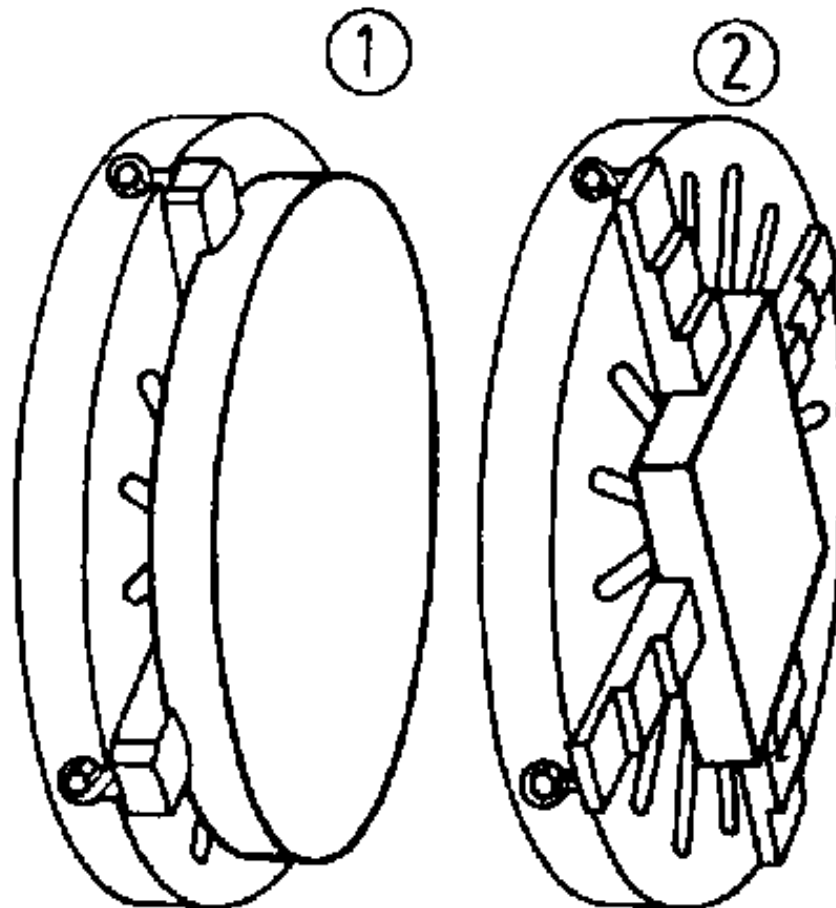

Figure 25. Faceplate

- ① clamping of large disks
- ② clamping of square workpieces

A very economical method of clamping is that on the mandrel, which is also called expansion arbor. It is put into the cleaned internal taper of the lathe spindle.

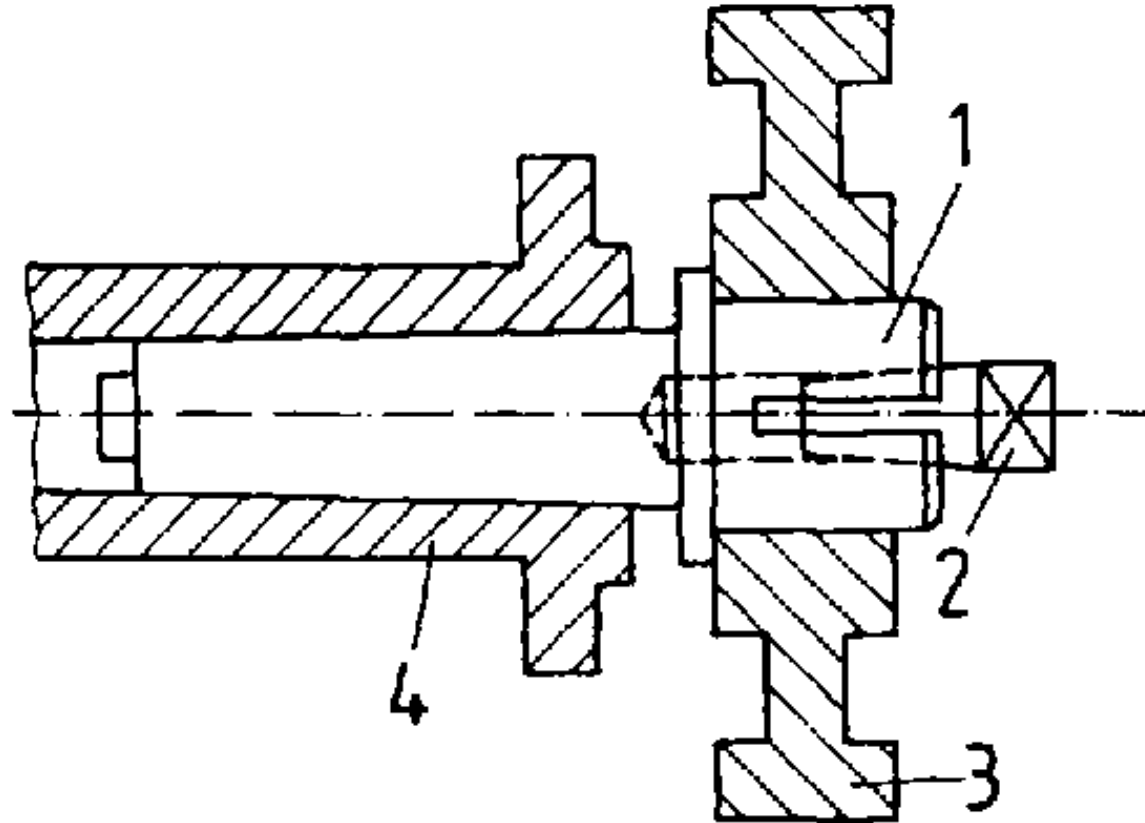

Figure 26. Arbor

1 clamping body, 2 taper plug, 3 workpiece, 4 lathe spindle

Premanufactured arbors can be adapted to various diameters by the lathe operator himself. They are especially suited for clamping levers and other irregularly shaped parts with a bore hole and save the use of complicated fixtures.

Other methods of clamping may be applied according to each respective kind of workpiece.

Clamping mistakes and their causes

Frequent clamping mistakes are:

- Too long projecting of the lathe tool - lathe tool is springy.
- Wrong setting-up at centre by too many backings and/or non-aligned backings - this causes chattering, canting, tool breaking,

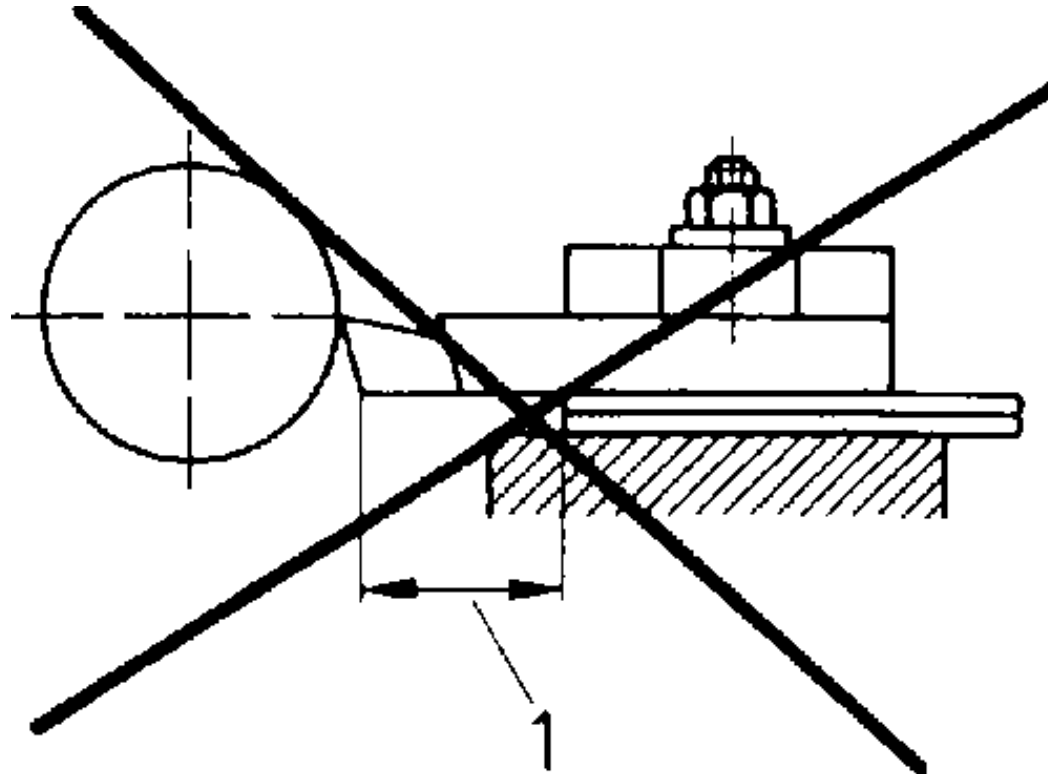

Figure 27. Lathe tool too much projecting

1 wrong clamping

- Inclination of the lathe tool due to overraised shank the consequences are: displacement of the cutting edge angles, the spindle of the clamp nut is tightened in

an oblique way.

Figure 28. Wrong setting at centre

1 too many backings, 2 inclined position of the lathe tool due to overraising of the shank, 3 distortion of the cutting edge angles, 4 spindle of the clamping nut not straight

- Wrong position of the clamping jaw and/or locking screws: the lathe tool is fixed only by one edge - the service life of the tool is reduced.

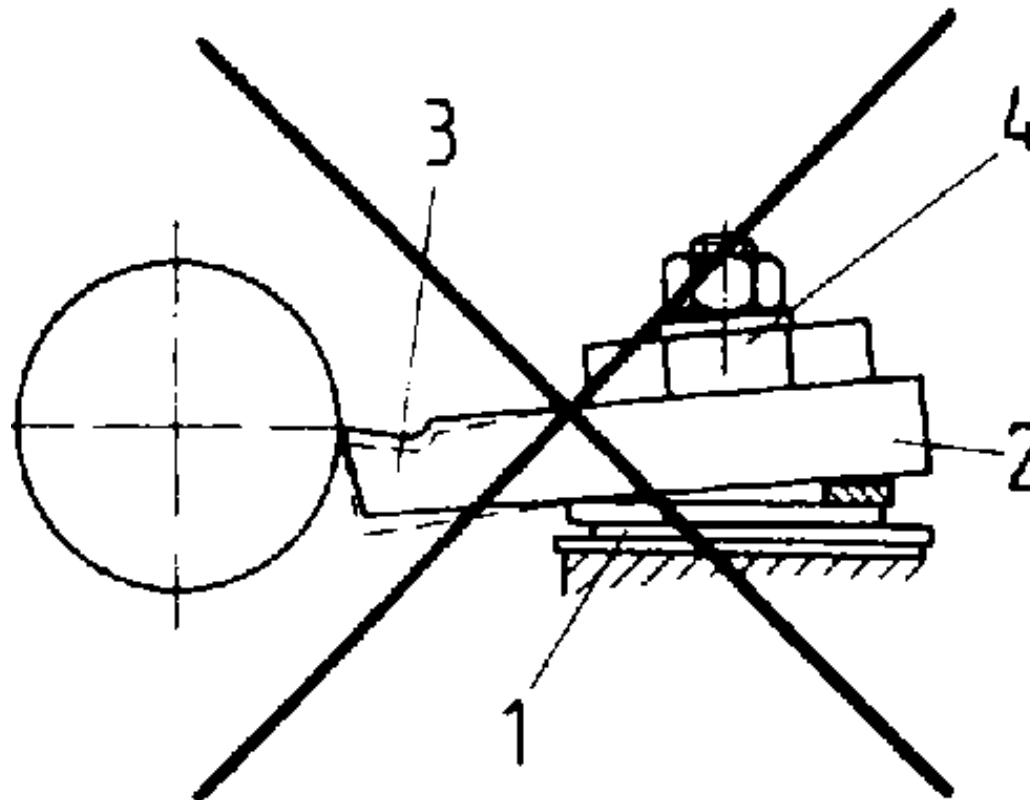
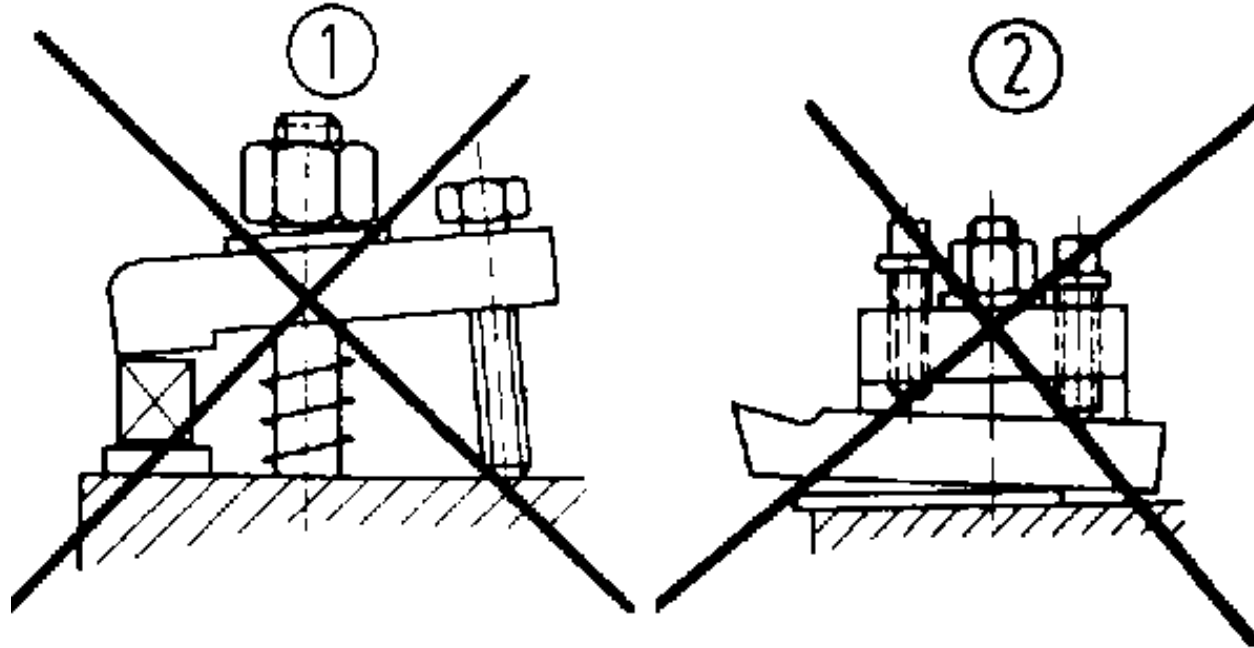

Figure 29. Wrong position of the clamping claw/clamping bolts

① clamping claw; ② clamping bolts

- Wrong position of the lathe tool: The tool is forced into the workpiece - risk of rejects.

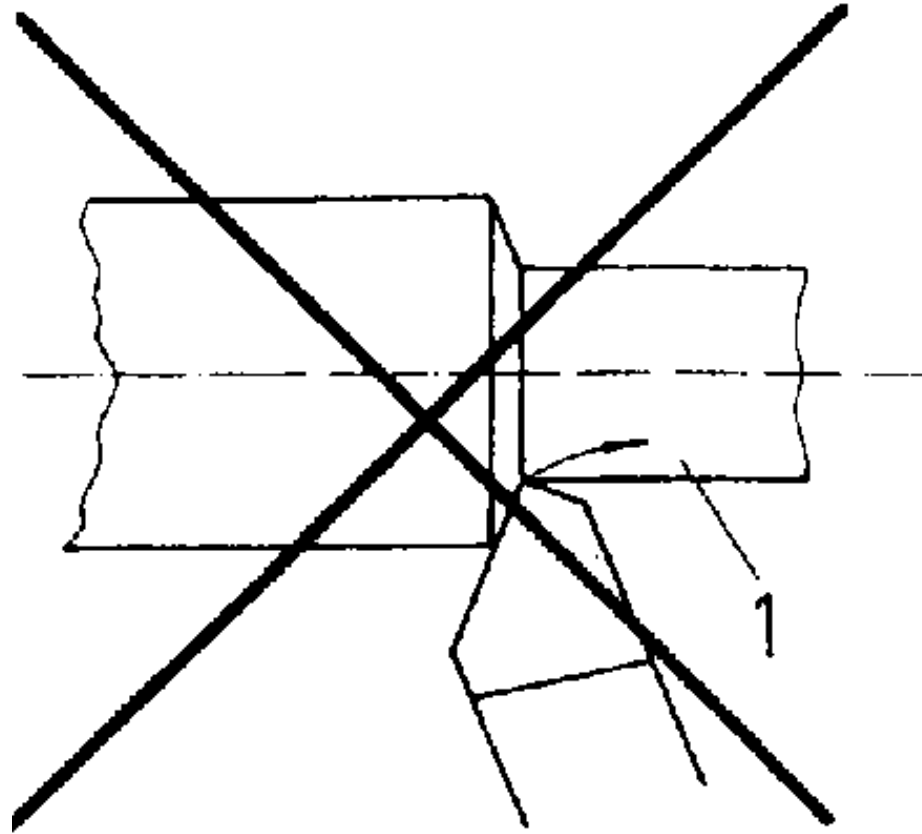

Figure 30. Wrong position of the roughing lathe tool

1 arrow points to the direction in which the tool is forced into the workpiece, workpiece becomes a reject

- Unclean quill: Foreign matters are between the tapers, which leads to rejects and tool breaking.

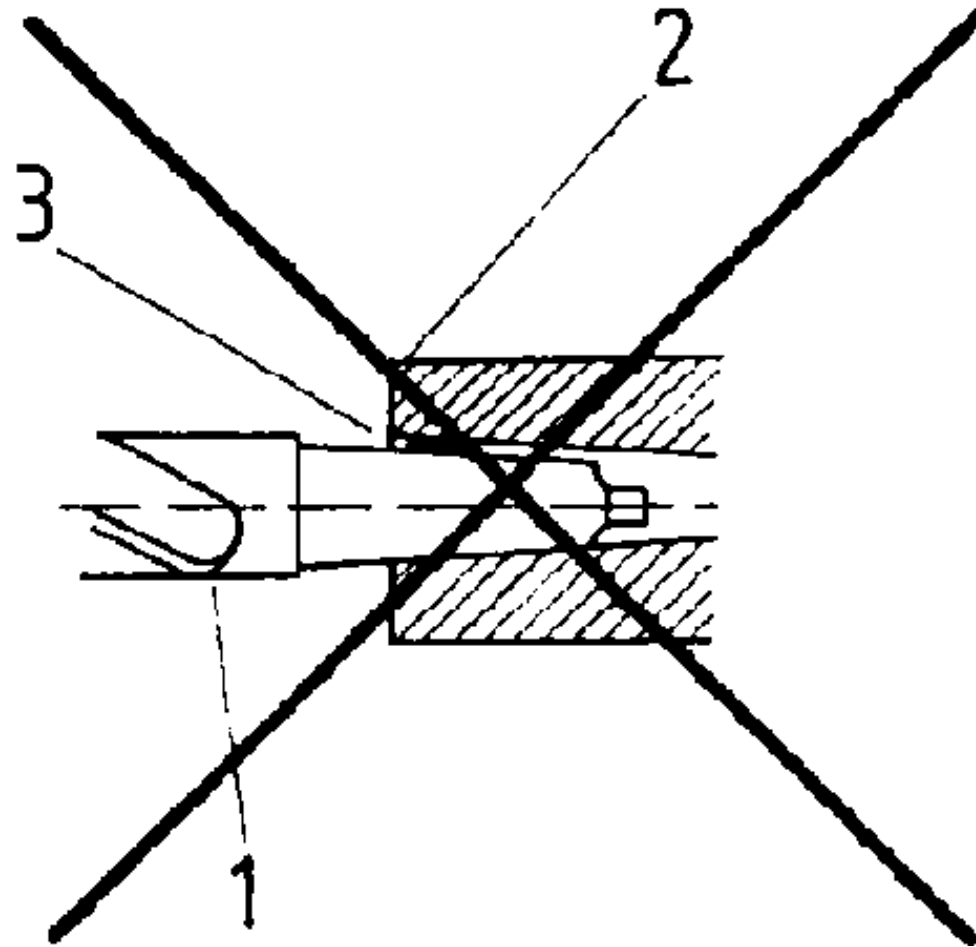

Figure 31. Foreign matters between the tapers

1 twist drill, 2 quill, 3 foreign matter

- Too much projecting of the workpieces and/or insufficient fitting to the clamping jaws - tool breaking due to chattering.

Rejects are also caused by canting of the workpiece.

Risk of accident when loosening the workpiece.

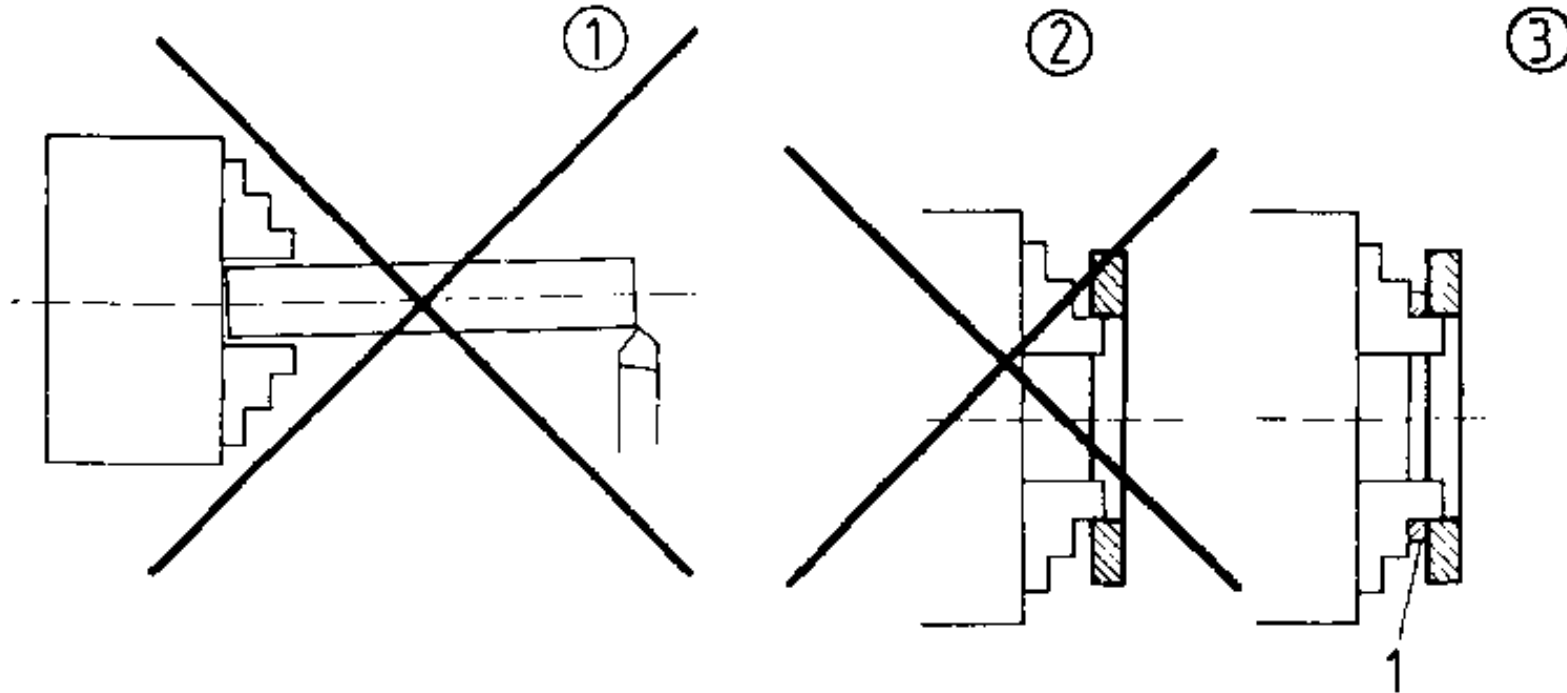

Figure 32. Workpiece projecting too much/ill-fitting clamping jaws

① too much projecting; ② thin workpieces clamped the wrong way; ③ thin workpieces are clamped against a supporting ring

1 supporting ring

How can workpieces be clamped?

What is the purpose of clamping in soft clamping jaws?

Determination of the settings (cutting values)

The settings (cutting values) resulting in the best possible economy can be determined only for one definite turning operation on one certain lathe. Cutting speed "v":

The speed v is the distance s covered in one unit of time, i.e.

$$v = \frac{s}{t}$$

The distance s can be expressed by any unit length, e.g. in mm or in m or in km. The unit of time forming the basis of the measurement of the speed can also be chosen in any measure of time, for instance in h (hours), in min (minutes) or in s (seconds).

For the purpose of a uniform determination of the cutting speeds in the turning process, the distance s is expressed in m and the time t in min.

$$v = \frac{s}{t}$$

v	s	t
m/min	m	min

The same applies to boring, counterboring, reaming, milling, broaching, planing, slotting and shaping, for which the cutting speeds are always given in m/min.

Pay attention to the fact, that sometimes cutting speeds are given in m/s, though.

If a workpiece completes one full rotation about its axis and if the diameter of this workpiece is d , each individual point on its surface covers a distance of

$$s = d \times \pi$$

If the same workpiece does not rotate only one time but n times about its axis, the distance each individual point of its surface covers is n times as long, i.e.

$$s = n \times d \times \pi$$

Since the diameter d enters this equation in mm, but the distance s shall be determined in m ($1 \text{ m} = 1000 \text{ mm}$), the equation reads as follows:

$$s = \frac{n \times d \times \pi}{1000}$$

s	n	π	d
m	-	-	mm

If the same workpiece again rotates n times about its axis, and if these n rotations are completed in exactly 1 min, it has the rotational speed of n per minute or n/min , which can also be written as follows: $n \text{ 1/min}$ or $n \text{ r.p.m.}$

The latter way of writing is used to indicate rotational speeds.

Since with the number of rotations completed in one minute the unit time of min has entered the equation, we now have no more just the distance s, but the distance s covered in one minute, that is to say, we are now dealing with a speed v.

Thus, the equation reads like this:

$$v = \frac{n \times d \times \pi}{1000}$$

v	n	d	π
m/min	r.p.m.		-

For example:

A workpiece of a diameter of d = 200 mm rotates along the lathe tool at n = 30 r.p.m. What is the peripheral speed v?

$$v = \frac{n \times d \times \pi}{1000} = \frac{30 \times 200 \times 3.14}{1000} = 18.84 \text{ m/min.}$$

The peripheral speed of the workpiece, at the same time, is the speed at which the turning is removed, i.e. the cutting speed.

Rotational speed "n": As is to be seen, there are certain relations between the cutting speed v, the diameter d and the rotational speed n.

A certain diameter and a certain cutting speed result in:

$$n = \frac{1000 \times v}{d \times \pi}$$

n	v	d	π
r.p.m.	m/min	mm	-

For example:

A disk of 200 mm shall be rough-machined at $v = 100$ m/min. The rotational speed n is to be determined.

Given: $d = 200$ mm, $v = 100$ m/min

Required: $n =$ r.p.m.

$$\text{Calculation: } n = \frac{1000 \times v}{d \times \pi} = \frac{1000 \times 100}{200 \times 3.14} = 159.24$$

159 r.p.m.

In planning pay attention, that the cutting speed, when reaching the centre, moves towards 0, i.e. the mean diameter is used for calculation.

With individual parts, a greater diameter may be chosen. With series, a smaller one may be taken in order to avoid frequent regrinding and setting-up.

Time is saved this way.

Cutting depth "a":

The cutting depth a in mm is the amount by which the lathe tool is fed before beginning a cut.

If possible, the entire machining allowance shall be removed in only one roughing and one finishing operation. With plain turning, it is calculated from the raw diameter d_r and the final diameter d of the workpiece according to the following equation:

$$a = \frac{d_r - d}{2}$$

Feed "s":

The feed, or better feeding distance s in mm is the progress of the lathe tool in the direction of the cutting movement after one rotation of the workpiece. It is selected from the in-feed scale of the lathe, which is determined by the feed gear, according to the proportion a : s.

By the cutting depth a and the feed s, the sectional area of chip F is determined:

$$F = a \times s$$

Therefore, for an economical turning, a certain chip proportion a : s must be observed.

With a great feed, a large quantity of chips is achieved - at the same time, the

performance of the machine is increased.

Further aspects in connection with the selection of the feed are the surface quality and the material of the workpiece. What diameter is chosen for the calculation of the cutting speed with finishing?

What is the equation for calculating the cutting speed?



[Home](#) > [ar](#).[cn](#).[de](#).[en](#).[es](#).[fr](#).[id](#).[it](#).[ph](#).[po](#).[ru](#).[sw](#)

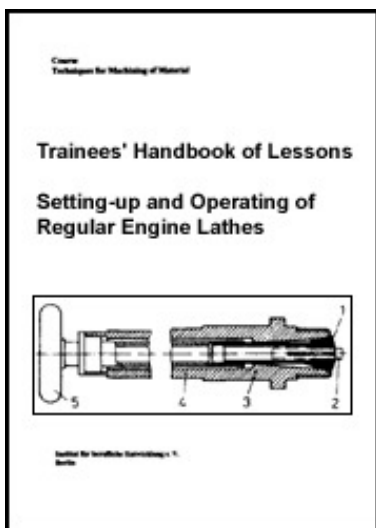

 **Setting-up and Operating of Regular Engine Lathes - Course: Techniques for machining of material. Trainees' handbook of lessons (Institut fr Berufliche Entwicklung, 35 p.)**

 **(introduction...)**

 **1. Importance of the regular engine lathe**

 **2. Structure of the regular engine lathe**

 **3. Structure and types of lathe tools**

 **4. Preparation of the work on the regular engine lathe**



5. Setting-up and operating the regular engine lathe

6. Maintenance and care of the regular engine lathe

5. Setting-up and operating the regular engine lathe

It belongs to the preparation of each respective operation that all working and auxiliary means required are provided in a useful way according to the regulations, so that they are accessible in the shortest possible time.

The setting-up and operating of the machine is carried out according to the following steps:

- Clamping of the workpiece

- Selecting the clamping means - the workpiece must rotate during the machining process and remain in its position even with the most difficult cuts. The various dimensions and shapes of the workpieces require various corresponding ways of clamping.**
- Selecting the clamping jaws - when using a clamping chuck.**
- Securing true running - perhaps by using soft clamping jaws.**
- With long workpieces - selection of a poppet.**

The workpieces have to be clamped short and firm according to their respective shape.

- Clamping of the tool

- **Short and firm clamping**
- **Always place in dead central position - backings according to the principle "as few as possible".**
- **Decide whether single or multi-tool holder are to be used.**

The tools must be examined as to their serviceability.

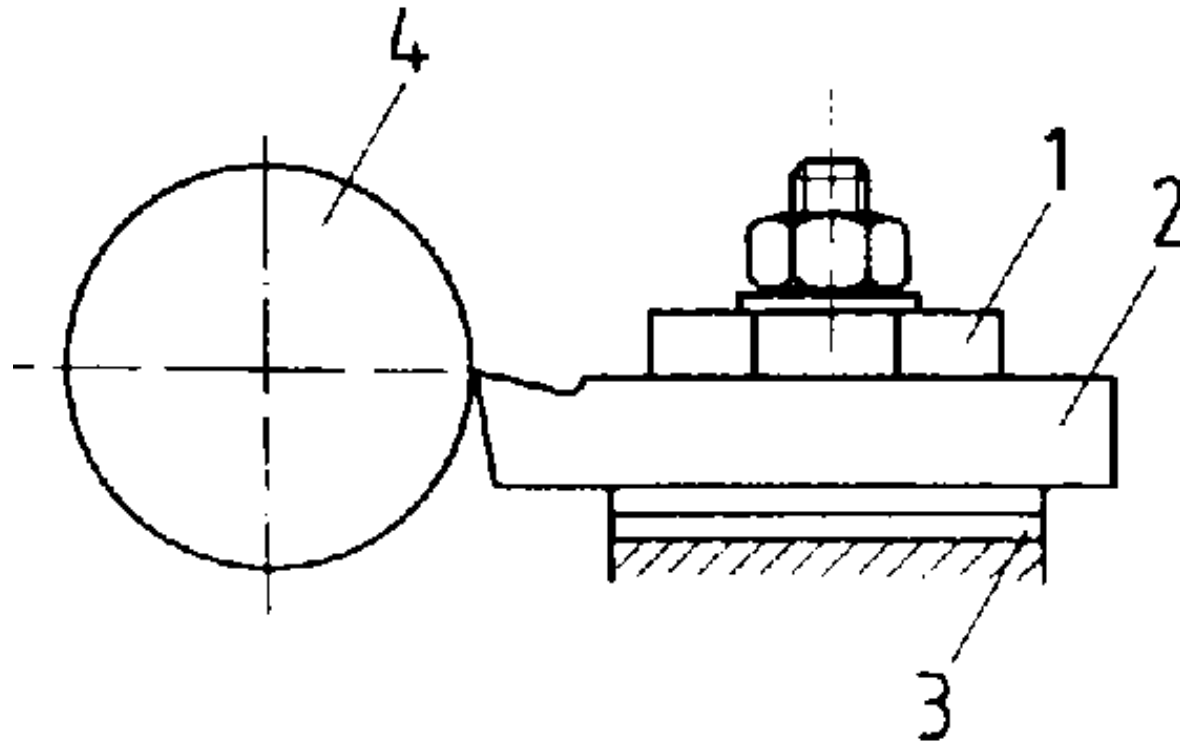

Figure 33. Clamping of the lathe tool

1 clamping claw, 2 lathe tool, 3 backings, 4 workpiece

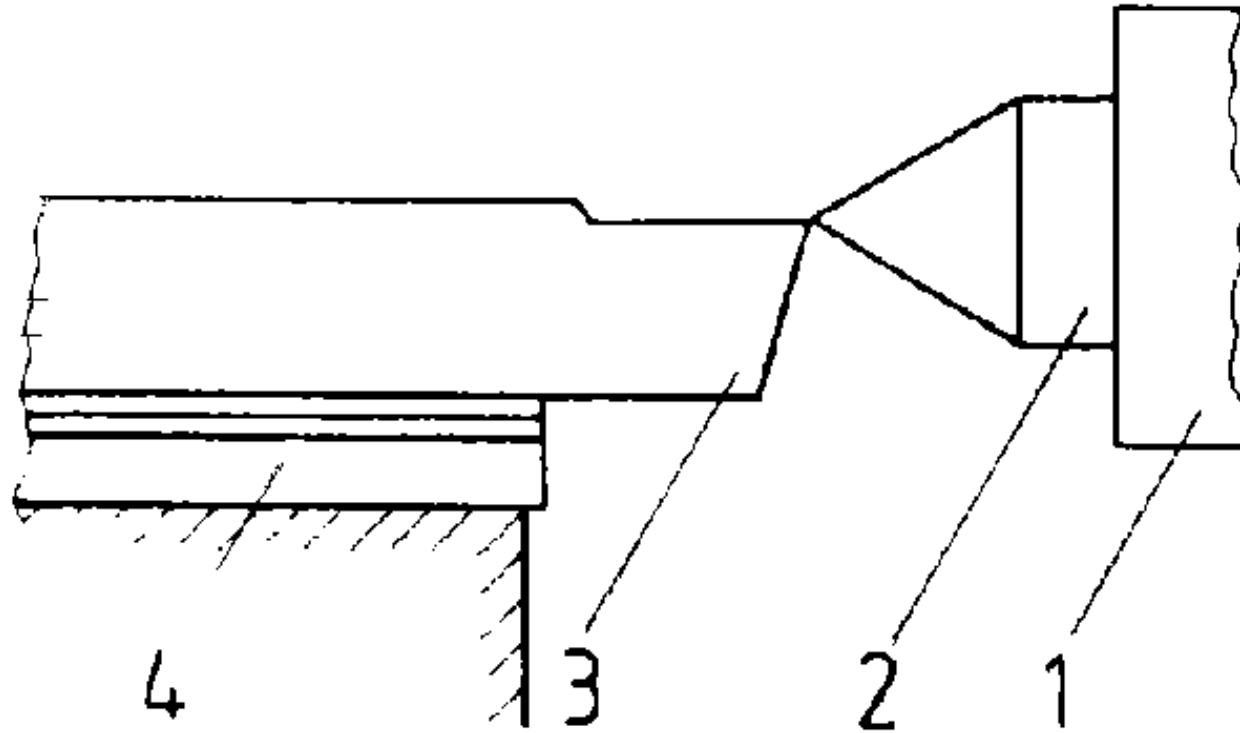

Figure 34. Vertical adjustment by tailstock centre

1 quill, 2 tailstock centre, 3 lathe tool, 4 backings

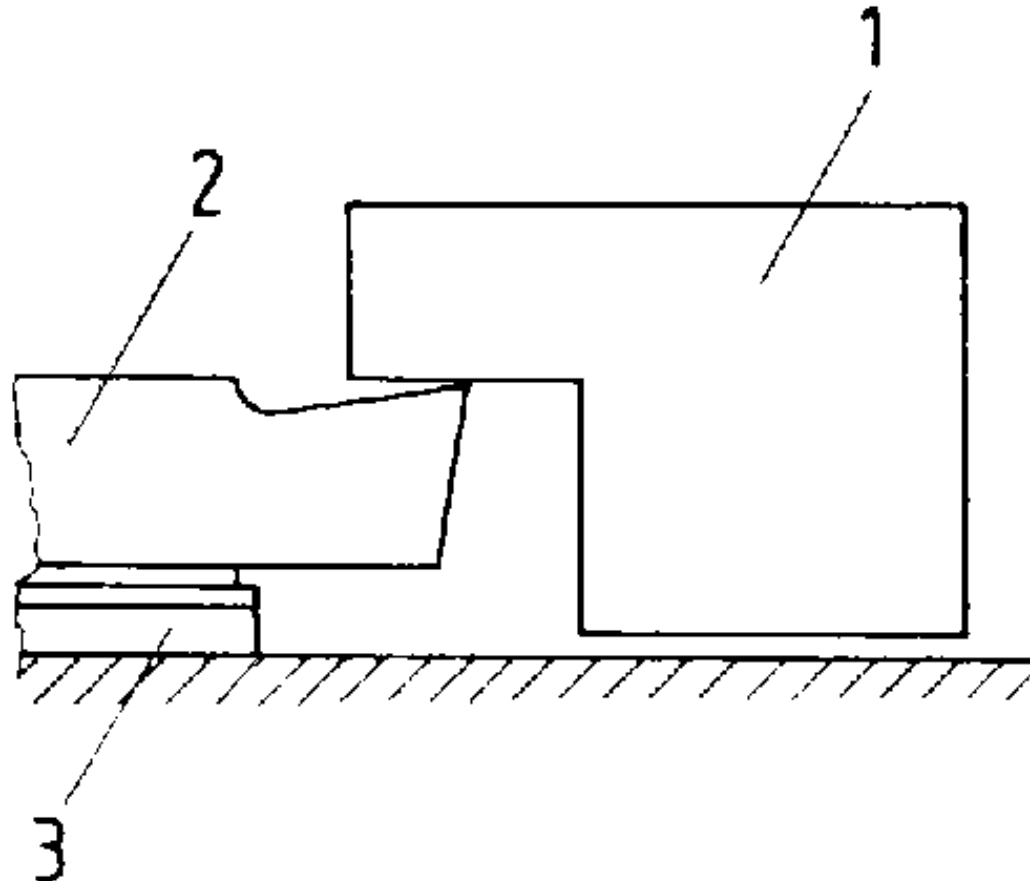

Figure 35. Vertical adjustment by setting gauge

1 machine-bound setting gauge, 2 lathe tool, 3 backings

- Setting-the cutting parameters

- **Setting of the rotational speed taking the existing speed tables and switching symbols into consideration.**

Switching only when the machine is at rest!

• Setting of the feed.

In case of replacement of the change gears, switch off the main switch before opening the gear case.

Why should the shims be selected according to the principle "as few as possible"?

What is the required rotational speed for machining a workpiece of St. 60 of a diameter of 65 mm using a carbide-tipped lathe tool?

a) For cylindrical turning

b) For surfacing

Formula: $n = \frac{v \times 1000}{d \times \pi}$ r.p.m.

Cylindrical turning:

Given: $v = 80 \text{ m/min}$ $d = 65 \text{ mm}$ $\pi = 3.14$

Required: n r.p.m.

Calculation:

=====

Surfacing:

Given: $v = 80 \text{ m/min}$ $d = 65 \text{ mm}$ $\pi = 3.14$

Required: n r.p.m.

Required.

Calculation:

=====

How is the rotational speed selected, when surfacing single parts or series?

What does the selection of the feed depend on?

For operating the regular engine lathe, the following rules have to be observed (sequence of operations):

- Switching the lathe on**
- Approaching the tool carrier with the lathe tool towards the workpiece**
- Entering the cut at the workpiece with the help of the hand feed**
- Infeed by tool rest and surfacing of the workpiece**
- Setting of the dog, length adjustment by log measure**
- Beginning the cut at the area of the cylindrical surface of the workpiece by hand feed**

Beginning the cut at the workpiece only with the machine running, because otherwise the main cutting edge of the lathe tool will chip.

- **Putting the scale of the cross slide on 0 and carry out the required feed operation for achieving the desired diameter (in the case of too much infeed, turn the crank back by one revolution in order to compensate backlash and start the feeding movement again).**
- **Starting the cut with 1-2 mm, then the tool carrier is returned (see fig. 36)**
- **Switching the machine off and dimensional inspection**
- **Switching the machine on - perhaps dimensional correction**
- **Switching on the automatic feed**
- **1 - 2 mm before reaching the stop, switch the automatic feed off and continue by hand feed till the stop is reached.**

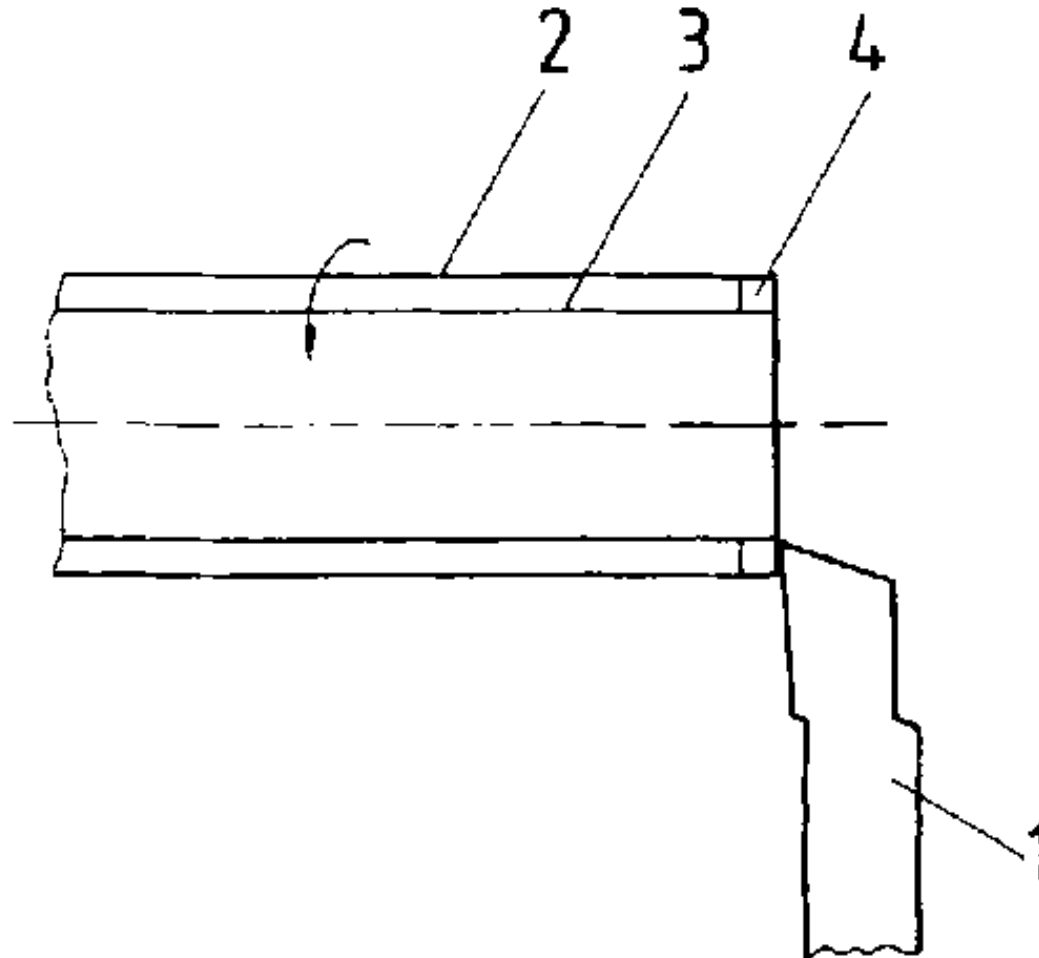

Figure 36. Starting the cut at the workpiece for dimensional inspection

1 right side cutting turning tool, 2 rough size of the workpiece, 3 final size of the workpiece, 4 starts of cuts at the workpiece for dimensional inspection

- Return cross slide (lathe tool)**
- Return tool carrier to original position**

- **Switching the machine off, dimensional inspection**

- **Unclamping of the workpiece.**

A workpiece has a diameter of 50.8 mm and shall be reduced to 50.4. By how many graduation marks must the crank be moved on if one graduation mark is equivalent to a lathe tool feed of 0.05 mm?

Solution:

What steps have to be taken if, with the tool infeed to final size, a too great feed was set by mistake?



[Home](#) > [ar](#).[cn](#).[de](#).[en](#).[es](#).[fr](#).[id](#).[it](#).[ph](#).[po](#).[ru](#).[sw](#)

 **Setting-up and Operating of Regular Engine Lathes - Course: Techniques for machining of material. Trainees' handbook of lessons (Institut fr Berufliche Entwicklung, 35 p.)**

 **(introduction...)**

 **1. Importance of the regular engine lathe**

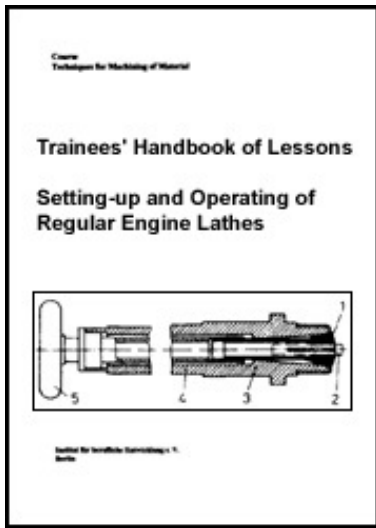

- 2. Structure of the regular engine lathe
- 3. Structure and types of lathe tools
- 4. Preparation of the work on the regular engine lathe
- 5. Setting-up and operating the regular engine lathe
- ➔ 6. Maintenance and care of the regular engine lathe

6. Maintenance and care of the regular engine lathe

Like all machine tools, regular engine lathes are subject to permanent wear.

By constant care and maintenance of the machines wear can be controlled and kept low.

The following principles have to be observed:

- The operating instructions are decisive for the use and maintenance of the machine. They must be carefully observed.
- Before beginning the daily work, all parts of the machine that have to be lubricated by hand have to be oiled according to the instructions. Unsufficient lubrication leads to early abrasion. For centralized and circulating lubrication make sure that the quantity of oil is sufficient.

The oil strainers have to be cleaned regularly and at the required intervals.

The following principle applies to the lubrication of a machine:

The prescribed quantity of the prescribed lubricant to the respective lubrication points of the prescribed time.

- Before putting the machine into operation make sure that all levers are in their correct positions. Wrong lever positions may lead to breaks.**
- All guideways must be protected against, chips, scale, dust and abrasion of any kind. Otherwise they will wear out soon and inaccurate work would be the result.**
- Guideway parts which are not used must be protected against contamination by protective equipment.**
- Make sure that the workplace is always in order. Clamping means and change gears must be kept in their proper places. On the regular engine lathe, the required tools must be well ordered and ready to hand on the protective boards.**

