

**Filing – Course: Technique for Manual Working of Materials.  
Methodical Guide for Instructors**



## Table of Contents

<b>Filing – Course: Technique for Manual Working of Materials. Methodical Guide for Instructors</b> .....	1
1. Objectives and contents of practical vocational training in the working technique of “Filing”.....	1
2. Organizational preparations.....	1
3. Recommendations for practical training in the working technique of “Filing”.....	3
4. Application of the working technique of “Filing”.....	10
5. Captions and legends of the “Filing” transparencies series.....	13



# **Filing – Course: Technique for Manual Working of Materials. Methodical Guide for Instructors**

**Institut für berufliche Entwicklung e.V.  
Berlin**

Original title:  
Methodische Anleitung für den Lehrenden  
“Feilen”

Author: Frank Wenghöfer

First edition © IBE

Institut für berufliche Entwicklung e.V.  
Parkstraße 23  
13187 Berlin

Order No.: 90–32–3105/2

## **1. Objectives and contents of practical vocational training in the working technique of “Filing”**

By concluding their training the trainees shall have a good command of the working technique of “Filing”. Therefore, the following objectives are to be achieved:

### Objectives

- Knowledge of purpose and application of the filing technique.
- Proper handling of files and capability of filing all surfaces, edges and break-throughs to size.
- Capability of selecting and properly using the appropriate tools and accessories.
- Capability of making decisions on quality independently.

The following contents have to be imparted to the trainees:

### Contents

- Purpose of filing
- Tools and accessories
- Effects and handling of files.

## **2. Organizational preparations**

In order to guarantee a trouble-free development of the instructions, exercises and practical work it is necessary to prepare this training appropriately.

The following steps have to be taken:

### 2.1. Preparations for instructions on labour safety

Prior to the exercises, a brief instruction on the proper use of tools and equipment has to be given. This comprises also hints for accident-free work.

The main emphasis is to be laid on:

- Files with crack-free file handles must be used only.
- New file handles are to be drilled and enlarged in relation to the tang of the file and then fixed by light blows with the hammer.
- Files are to be protected from dropping and must not be laid one above the other.
- Hardened components must not be filed – danger of slipping!

Familiarity with these hints has to be confirmed by the trainees' signatures in a control book,

## 2.2. Provision of teaching aids

- For demonstration purposes during the instructions, a vice has to be firmly installed at the place.
- The "Trainees' Handbook of Lessons – Filing" is to be handed out to the trainees in sufficient numbers.
- When using the transparencies series of "Filing", check whether they are complete (transparencies nos. 5.1. – 5.5.) and whether the overhead projector is functioning. (Check the operating conditions at the place of use and make sure of the proper mains supply!)
- Surveys etc. which are to be written on the blackboard have to be completed prior to the instruction,
- All the tools and accessories mentioned in section 3 (for filing purposes) should be kept ready for illustration purposes.

## 2.3. Provision of working tools and materials

- The "Instruction Examples for Practical Vocational Training – Filing" must be handed out to the trainees in sufficient copies to provide them with the theoretical foundations for the exercises to be carried out.
- The initial materials necessary for the exercises have to be prepared and laid out in sufficient numbers according to the materials mentioned in the "Instruction Examples ..."
- Each trainee is to be provided with a workbench at which a vice is firmly installed (check the proper height of this vice!)
- The trainees' workbenches have to be fully equipped with tools and accessories according to the envisaged exercises.

Recommended basic equipment:

- steel rule, vernier caliper, bevelled edge square, protractor
- steel scribe, prick punch, dividers
- hand hacksaw, locksmith's hammer
- bastard and smooth files 200 – 300 mm (flat, three-square, round)
- warding file (flat)
- In order to carry out the necessary preliminary work (drilling), bench-type or column-type drilling machines with necessary clamping devices (machine vices, holding clamps, C-clamps) are necessary.

- Before the exercises are carried out, the drilling machines must be checked in order to find out whether their functionality complies with the requirements of labour safety.

#### 2.4. Time schedule

Time planning is recommended for the following training stages:

- introduction to the working technique in the form of instructions
- necessary demonstrations
- job-related instructions to prepare the exercises
- carrying-out the exercises
- recapitulations and tests.

The necessary time-share depends on the respective training conditions. Most of the time is to be allocated to the exercises.

### **3. Recommendations for practical training in the working technique of “Filing”**

The following paragraphs comprise proposals on conducting trainee instruction, the demonstration of working techniques as well as the exercises and tests.

The following sequence of stages is recommended:

- Introductory instruction with demonstrations from the “Trainees’ Handbook of Lessons”
- Exercises in “Filing” based on the “Instruction examples 5.1. to 5.6.”
- Final test of theory knowledge based on the contents of “Examples for Recapitulations and Tests”

Practical skills should be evaluated immediately after having received the trainees’ test workpieces. Knowledge of theory should be constantly checked, however, it is recommended that a final test paper should be written after concluding the exercises.

#### 3.1. Introductory instruction

If possible, this instruction should be conducted in a classroom.

Make sure, that the trainees put down necessary and supplementary notes or answers to questions in their “Trainees’ Handbook of Lessons”.

Instruction can be carried out on the basis of the main points contained in the “Trainees’ Handbook of Lessons”.

The two major subjects of “Purpose of Filing” and “Tools and Accessories for Filing” should be taught in such a way that all the teaching aids available are employed.

##### Purpose of filing

This subject can be explained to the trainees by employing work-pieces which had been worked with files. The trainees will learn that these workpieces reveal all the signs of a single-piece production.

The trainees will learn – and this is to be emphasised – that the finishing of surfaces or shapes is one of the major applications of the filing technique and that they must have a good command of this skill.

##### Tools and accessories

Introducing the subject of files should be begun with a flat file. The design of this tool can be illustrated by referring to the original tool and to the illustrations contained in transparency no. 5.1.

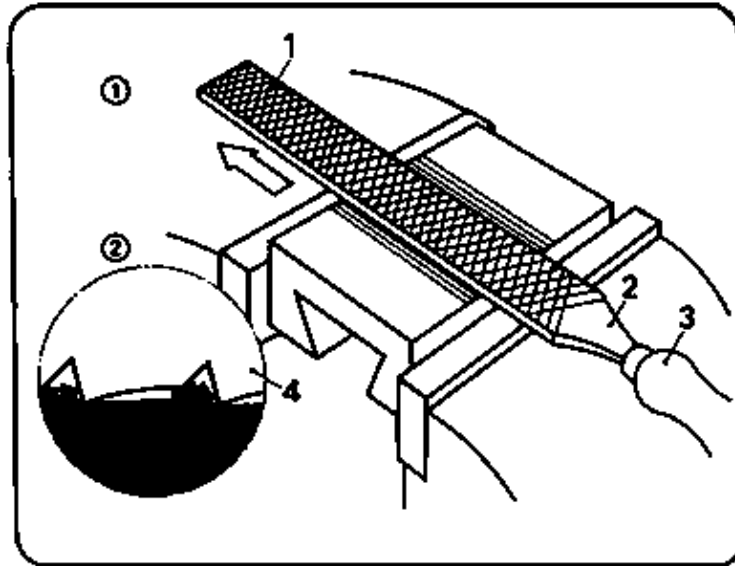

5.1

This is also the time to demonstrate the kinds of fixing file handles to the file blade. This will be followed by introducing the other types of files contained in the list of the "Trainees' Handbook of Lessons":

- flat file
- square file
- triangular file (three-square file)
- round file
- half-round file
- crossing file
- barrette file
- knife-edge file.

The demonstration of original tools can be supported by showing the illustrations contained in the transparencies nos. 5.2. and 5.3.

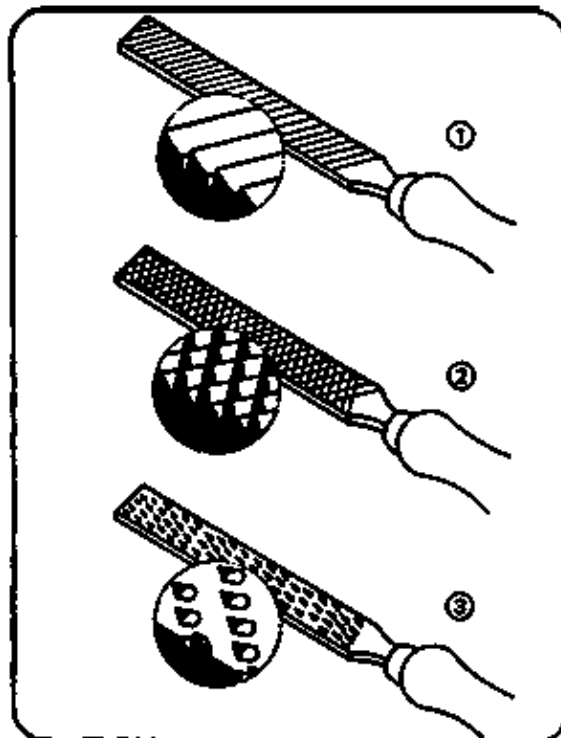

5.2



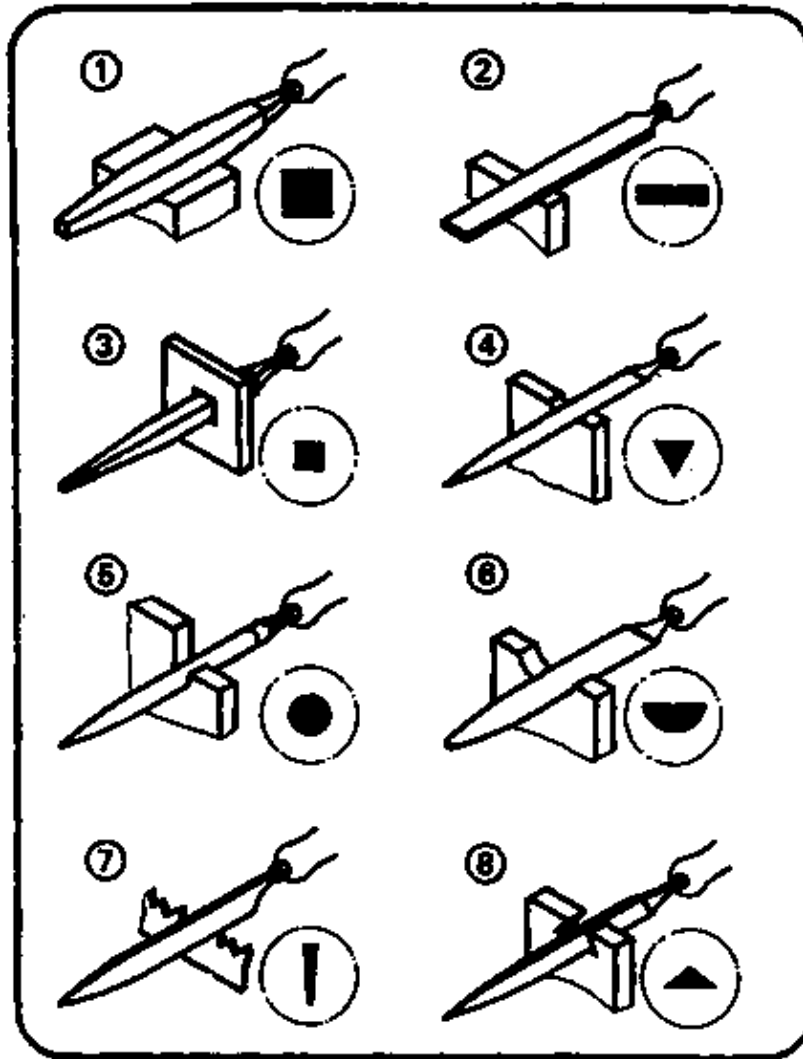

5.3

The trainees have not only to know the types of files but also how to use them. In this context the instructor has to mention that the use of files depends on their sizes and kinds of cut (single-cut, double-cut, rasp-cut).

The following survey (written on the blackboard) can be employed to finalise the instruction:

Designation Cut	no.	File surface	Use of file	Fineness of file
rough-cut file (roughing file)	0	rough (stroke of file tangible and visible)	for oversize of 0,5 mm and more	very coarse
bastard file	1			
second-cut file (coarse finishing file)	2	fine (file stroke no longer tangible but still visible)	for oversize of less than 0.1 mm	

smooth-cut (finishing file)	3			
dead-smooth file (fine finishing file)	4	very fine (file stroke neither tangible nor visible)	for fits and best surface finish	
super-smooth file (superfine finishing file)	5			very fine

The introduction of accessories should be linked with remarks on their respective application:

- vice
- vee clamps
- angle clamps
- protective jaws
- clamping jaws for round material
- clamping jaws for bolts and thread clamps
- saw sharpening vice
- hand vice and pin vice
- sheet metal dog vice

This is also the appropriate moment to mention that such accessories can be easily produced by everybody.

The subsequent working techniques contained in this course will give some ideas of how to manufacture these accessories during practical exercises.

#### Action of filing, postures of trainees and guidance of files

Transparency no. 5.1, as well as the illustrations contained in the “Trainees’ Handbook of Lessons” can be employed to describe the action of filing. The different actions of milled and chiselled files should be explained. It is to be mentioned that the use of chalk on surfaces will support the job of fine finishing.

The instructor must demonstrate the correct posture and guidance of the file when instructing the group. This can be demonstrated very effectively, if a vice is available in the classroom. If this is not the case, the sequence of motions has to be demonstrated quite clearly.

The instructor has to emphasise that the file must be moved by the motion of the arms only and that it must work in pushing direction only.

After these demonstrations each trainee should demonstrate the filing movement and posture. The instructor should see to it that all the trainees take part in evaluating the performance of their fellow-trainees.

#### Handling of files

If there is a vice available in the classroom, the following major subjects should be imparted to the trainees within the framework of the introductory instruction. The main method involved in these instructions should be that of demonstrating the practical use of these files. If such a demonstration cannot be given in the classroom, the instruction is to be continued in the workshop.

The instructor has to show how differently large, medium-size and small files have to be handled. Special emphasis is to be laid on the correct handling of file blades by the guiding hand.

Subsequently, the kinds of stroke (oblique stroke, cross stroke, longitudinal stroke) have to be demonstrated when filing flat surfaces. The trainees have to see that these kinds of stroke, when applied step by step, will improve the degree of evenness and surface finish.

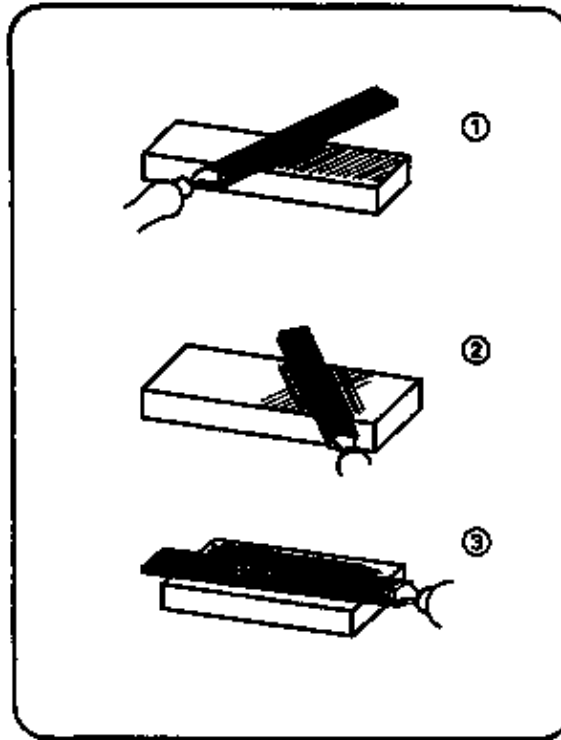

5.4

Transparency no. 5.4. should be employed as an additional teaching aid. Subsequently, testing of faces by means of bevelled steel straight-edge and bevelled edge square should be demonstrated.

There should be separate demonstrations of filing curved surfaces on small- and large-size external radii materials, stressing the different way of handling the file.

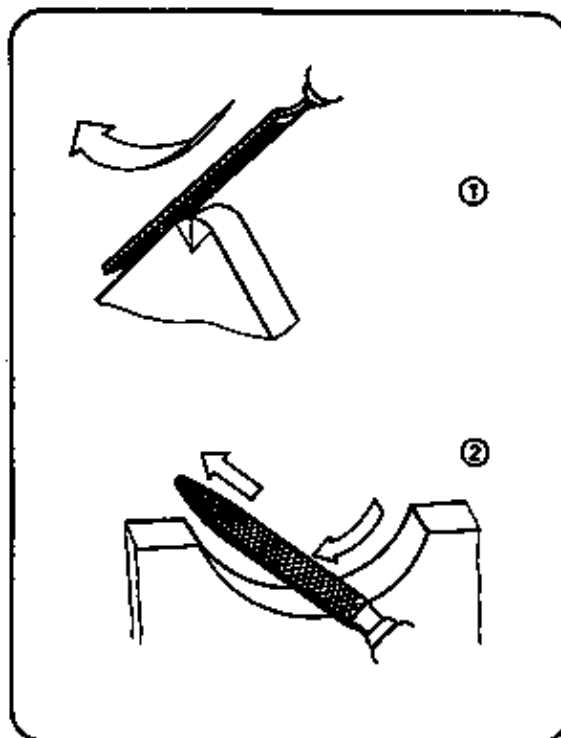

5.5

This fact is also illustrated by transparency no. 5.5. and illustrations in the “Trainees’ Handbook of Lessons”.

The instructor has to show how internal round surfaces have to be filed with different files depending on the size of the internal radii (round file, half-round file, crossing file). This should be followed by instructions in checking these radii with radius gauges and fillet gauges.

Pre-finished workpieces (sawn or drilled) must be prepared to demonstrate the working technique of filing cuts and breakthroughs. Depending on the shape of the cut or break-through the instructor has to select the appropriate form of the file. A separate section of instruction serves to demonstrate the filing of chamfers on large-size and small-size workpieces (employing a saw sharpening vice) as well as on round materials (bolts). The different ways of handling the files have to be underlined. This is also supported by the illustrations contained in the "Trainees' Handbook of Lessons".

The instructions should be concluded by the trainees' answers to questions asked in the "Trainees' Handbook of Lessons".

### 3.2. Exercises

If it has not been possible to include the individual demonstrations in the instructions, this should be done right now prior to the exercises. Subsequently, it will be possible to commence with the first exercise contained in the "Instruction Examples for Practical Vocational Training". However, it is necessary to prepare every individual exercise by a "job-related instruction" during which the trainees are shown a finished workpiece in order to demonstrate the objectives and purpose of the exercise.

The instructor must have made such a workpiece himself in order to be familiar with all the problems which might arise in producing such a workpiece.

Thus, the instructor can mention the criteria for evaluation as well as the problems involved in manufacturing such a workpiece. During these instructions the sequences of operation and the working drawings of the "Instruction Examples" should be placed on the desks so that the trainees can make notes therein. All the trainees can carry out these exercises simultaneously, if the material prerequisites are given (availability of a sufficient number of tools etc.). This being the case, any individual exercise should be carried out individually with each trainee being allowed to take the time he needs.

If this is not the case, the trainees have to be grouped in teams depending on the subject of work and number of the available working tools.

Trainees who cannot begin with filing should do other jobs in the workshop:

- selection and preparation of initial materials,
- checking and minor repair work on working tools under the supervision of the instructor,
- exercises which consolidate skills in the working techniques acquired in the past.

### 3.3. Examples for recapitulation and tests

This section comprises questions which are to consolidate and test the acquired skills and knowledge. Each question is provided with the respective answers. Questions which are also contained in the "Trainees' Handbook of Lessons" are marked with the letter "A".

1. What is the purpose of filing?

(To change flat or curved surfaces or edges of pre-worked components in terms of dimensions, forms and surface finish).

2. When is it useful to employ files?

"A" (In case of single-piece production, for repair work, and sometimes for assembly work).

3. Which of the file forms is the mainly used form?

"A" (Flat file).

4. Which type of cut is used for filing general steel grades and cast iron?

“A” (Double-cut file).

5. What is the order of files from coarse to fine surface finish?

(Roughing file – bastard file – coarse finishing file – finishing file – fine finishing file – superfine finishing file).

6. How do we select files?

(We have to consider the form of the surfaces or edges to be filed, the hardness of the material to be filed, the size of the surface to be filed, the amount of work and the surface finish).

7. How does a file act?

(Its many wedge-shaped teeth penetrate into the workpiece by means of pressure from above and to the front and remove chips).

8. Why are milled files well-suited to soft materials?

“A” (They are provided with very sharp teeth and small wedge-angles resulting in a cutting action).

9. Why are chiselled files well-suited to hard materials?

“A” (Their teeth have large wedge angles and exert a shaving effect).

10. Why must the files be operated with the arms in motion and the upper part of the body kept steady?

“A” (Otherwise the motion of the file would become arch-like instead of being horizontal and the filed surface would not be flat).

11. What is the difference in handling large and medium-size files?

(In the case of large-size files the guiding hand rests completely on the file blade, whereas thumb and finger of the guiding hand will grip the file blade of medium-size files).

12. Which kinds of strokes have to be employed successively when filing flat surfaces?

“A” (Oblique stroke, cross stroke, longitudinal stroke).

13. Why can only cross-stroke files be used to achieve flat surfaces of good surface finish?

“A” (The alteration in the direction of working makes it possible to recognize elevations and depressions on the worked surface very well by the working tracks left on it).

14. What is typical of file movements when filing small external radii?

“A” (Rocking feed movement opposite to the radius in the longitudinal direction of the curvature).

15. Which are the requirements to be met when using files for working internal radii?

“A” (The file must have a smaller radius than the curvature of the workpiece).

16. What is the difference in filing chamfers on large and small components?

“A” (With large-size components the file position will be 45° upwards; with small-size components the file position will be horizontal – the component should be fixed in a saw sharpening vice).

17. Which are the conditions to be met when clamping the work-piece?

“A” (You must clamp the workpieces so firmly and safely that the components will not spring or slip. The file position must be horizontal).

18. Which are the proper devices for clamping workpieces?

“A” (Vice, sheet metal dog vice, protective jaws of soft metal, clamping jaws for round pieces, vee clamps, thread jaws).

#### **4. Application of the working technique of “Filing”**

The sequence of exercises can follow the order of the 6 exercises mentioned in the “Instruction Examples for Practical Vocational Training”.

These “Instruction Examples ...” comprise a list of materials (initial material, working tools, measuring and testing tools, accessories) as well as the sequence of operations for the manufacture of these workpieces; also contained is an illustrative working drawing.

Thus, the trainees have the necessary information to begin their exercises.

If the quality of the produced workpieces should be considered insufficient, the trainee has to carry out comprehensive preliminary exercises. For this purpose any waste parts may be used. If the respective skill has been practised sufficiently, the envisaged workpiece can be produced.

The following hint should be taken into consideration:

The trainee has to do all the work involved alone – from the very beginning till completion.

This is the only way to guarantee a just evaluation of the achievements.

Should the offered “Instruction Examples ...” not be used in the exercises, then it is also possible to select other parts for practising. In this case all the working techniques acquired earlier should be also practised when working these pieces.

##### **4.1. Instruction Examples**

What follows is a brief description of the individual instruction examples in order to give a survey of the parts to be produced for practising the knowledge acquired:

Instruction Example 5.1.

Step Block

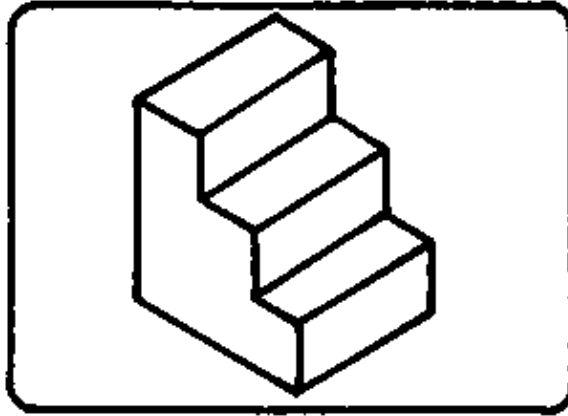

Filing of flat surfaces of square steel to finishing quality and of sawn out, stepped surfaces of small dimensions. Together with the parts produced as instruction examples 2.2., 5.2. and 5.5., it can be used as part of a set of clamping tools for an upright drilling machine.

Instruction Example 5.2.  
Sliding Block

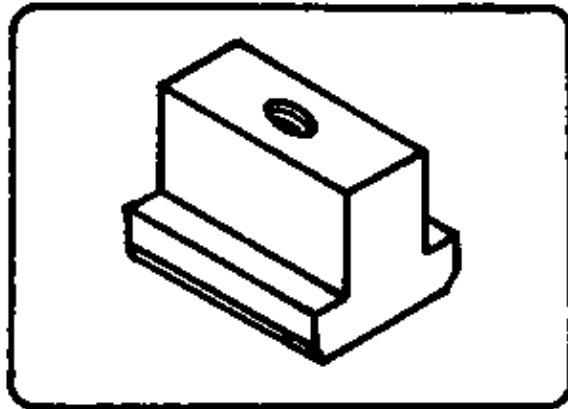

Filing of flat and stepped small-size surfaces of square steel to finishing quality and angularity. Additionally, the trainees practise filing of chamfers. Together with the components produced as instruction examples 2.2., 5.1. and 5.5. it will form another part of the set of clamping tools for an upright drilling machine.

Instruction Example 5.3.  
Locksmith's Hammer

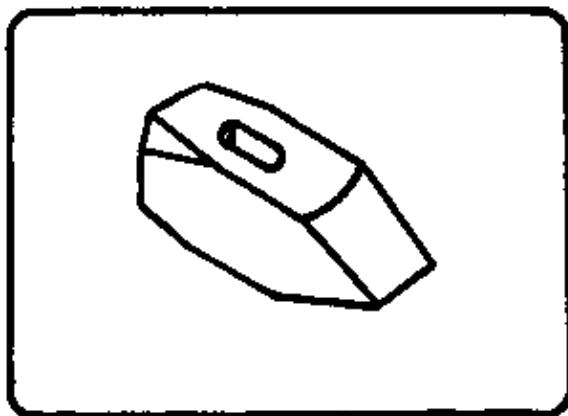

Filing of flat and inclined surfaces, radii, a break-through and chamfers on square steel. After being hardened, the locksmith's hammer can be fitted with a handle and be used in the workshop.

Instruction Example 5.4.  
Hexagon Socket Wrench

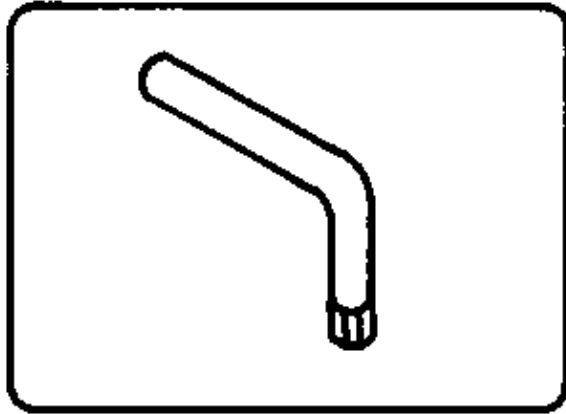

This exercise concentrates on filing small-sized, stepped surfaces on round steel materials. Angularity and accuracy to size are essential. A new degree of difficulty is added by filing a chamfer on round material.

After hardening this workpiece it may be used for mounting hexagonal socket-head bolts in the workshop.

Instruction Example 5.5.

Box Wrench

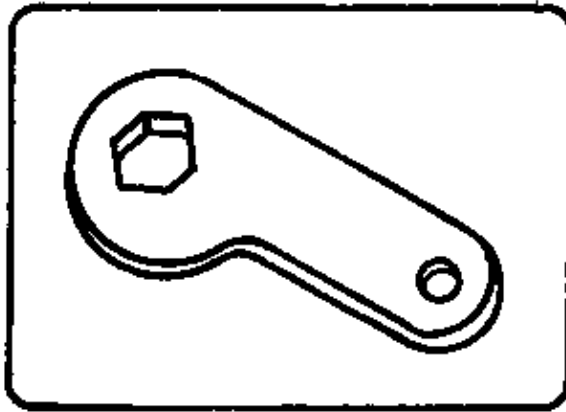

This filing practise concentrates on flat and curved narrow steel plate surfaces. The trainee will also practise how to produce a true-to-size hexagonal break-through.

Being part of a set of clamping tools for an upright drilling machine the size of this part complies with the size of the components produced as instruction examples 2.2., 5.1. and 5.2.

Instruction Example 5.6.

Bevel

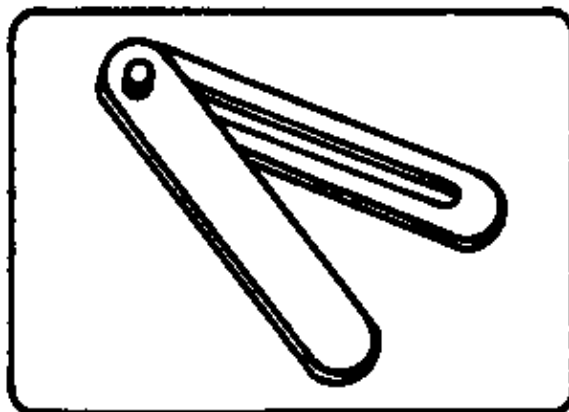

Here, too, flat and curved surfaces of flat steel are filed to finishing quality. Extremely difficult tasks are



associated with a long break-through on a single component. This bevel can be used for transferring angle values in the workshop.

#### 4.2. Criteria for practical training

It is recommended to determine some major points of observation and evaluation of the work to be performed.

The following criteria can serve as a guideline:

##### Flat surfaces and edges

- Is the trainee's posture correct?
- Does the trainee handle the file exactly horizontally or does the file “swing” over the surface?
- Does the trainee apply the oblique stroke technique to roughing?
- Does the trainee supply the cross stroke technique to achieve flat surfaces?
- Does the trainee apply longitudinal strokes to finishing filing?
- Does the trainee know how to check with the bevelled steel straight-edge or bevelled edge square?

##### Curved surfaces

- Does the trainee handle the file in the longitudinal direction of the round surface (with small-size round forms) and does he rock the file opposite to the radius?
- Does the trainee handle the file at right angles to the radius (with large-size round forms) and does he incline the file slightly?
- Does the trainee use a file with a smaller radius than the curvature for big internal radii?

##### Cut-outs and break-throughs

- Does the trainee employ the proper kind and size of file (in relation to cut-out and break-through)?

##### Chamfer

- Does the trainee employ the file at an angle of 45° with the file pointing upwards for large-size workpieces?
- Does the trainee use the saw sharpening vice when filing small-size components?
- Does the trainee handle the file laterally inclined and tilting towards the outside when filing round workpieces?

## 5. Captions and legends of the “Filing” transparencies series

Transparency no. 5.1.: Design and action of a file

(1) flat file

1 – file blade

2 – tang

3 – handle

(2) chip removal by  
the file teeth

4 – file tooth

Transparency no. 5.2.: Kinds of cuts

(1) single-cut file

(2) double-cut file

(3) rasp-cut file

Transparency no. 5.3.: Use of files

(1) square rubber file

(2) flat file

(3) square file

(4) triangular file

(5) round file

(6) half-round file

(7) knife-edge file

(8) barrette file

Transparency no. 5.4.: Filing of flat surfaces

(1) oblique-stroke  
filing

(2) cross-stroke filing

(3)  
longitudinal-stroke  
filing

Transparency no. 5.5.: Filing of curved  
surfaces

(1) filing of external  
radius – employing a  
flat file

(2) filing of Internal  
radius – employing a  
half-round file.