

TURNER

1st YEAR

TRANSPARENCIES



CIM CENTRAL INSTRUCTIONAL
MEDIA INSTITUTE, CHENNAI
AN INDO - GERMAN PROJECT



Directorate General of Employment & Training, Ministry of Labour, Govt. of India.

Developed by
CENTRAL INSTRUCTIONAL MEDIA INSTITUTE
in collaboration with DEUTSCHE GESELLSCHAFT FUER TECHNISCHE ZUSAMMENARBEIT (GTZ) Germany
P.O.Box 3142, 76, GST Road, Guindy, Chennai - 600 032. Phone: 234 5256, 234 5257. Fax: (0091 44) 234 2791

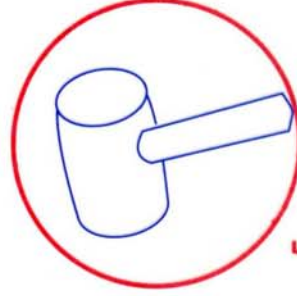
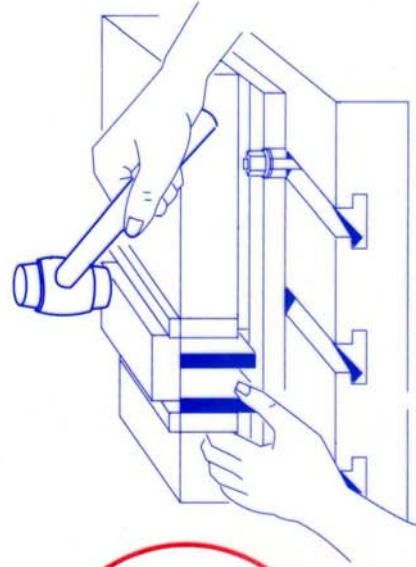
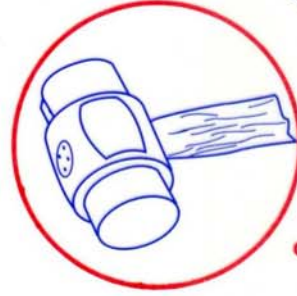
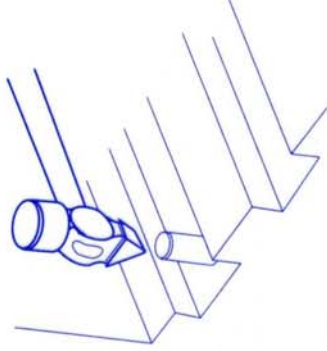
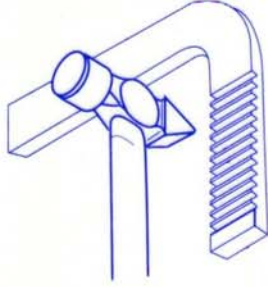
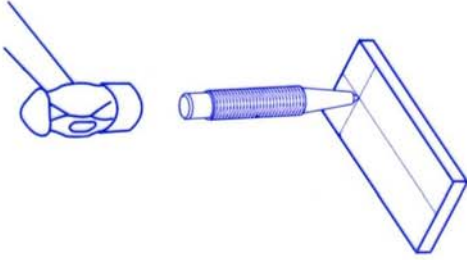
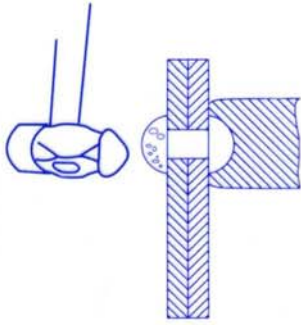

HAND HAMMERS - APPLICATIONS

TR0101010193

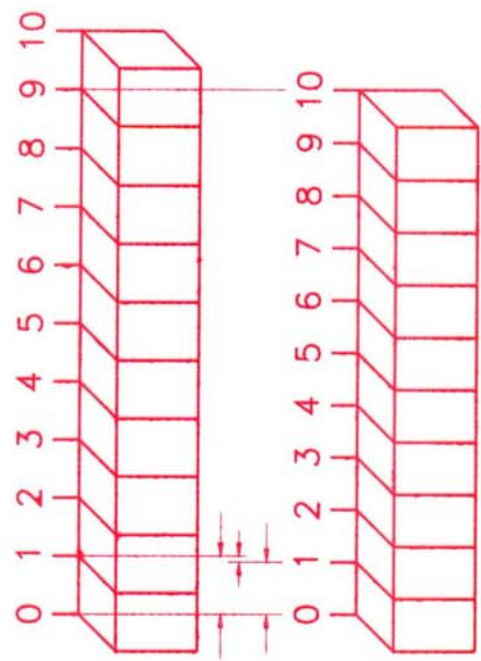
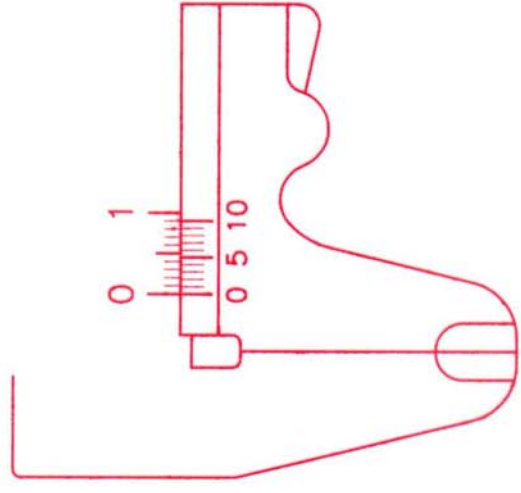
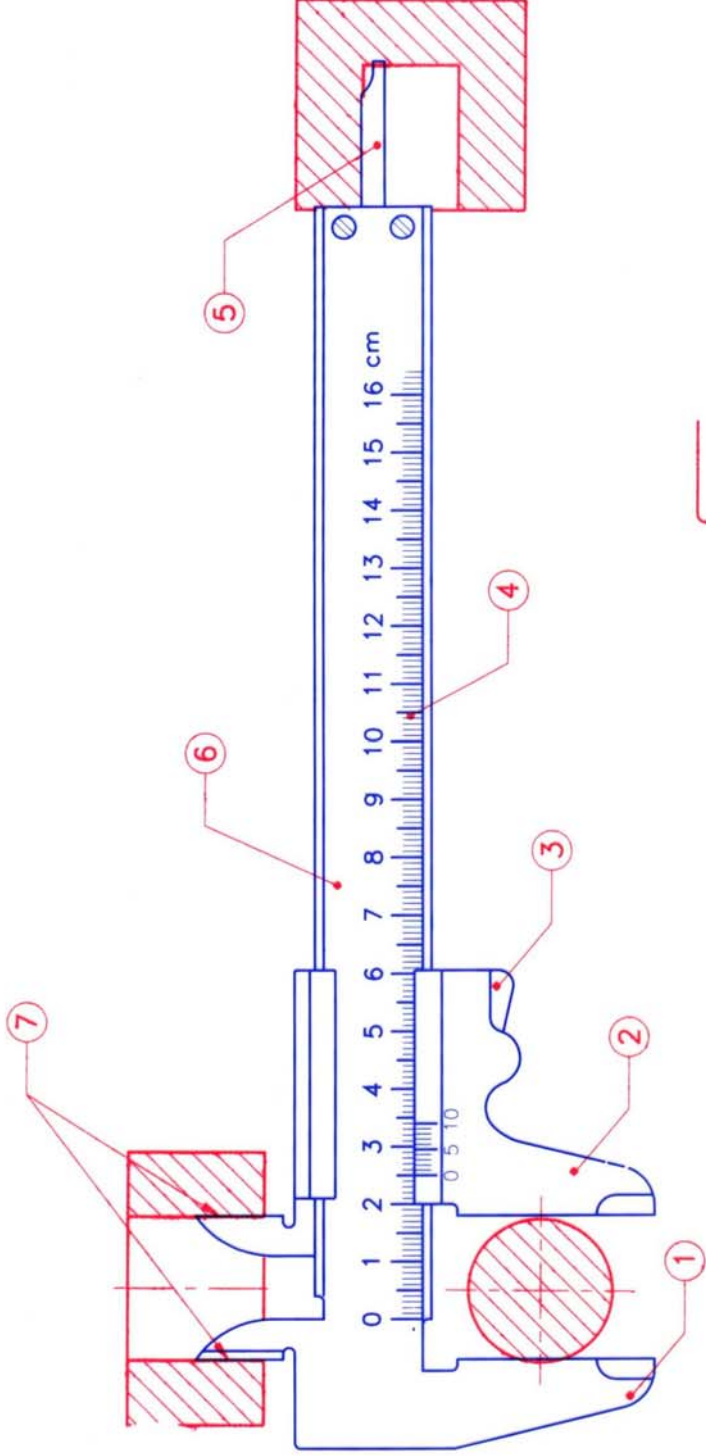

VERNIER CALIPER PARTS AND PRINCIPLE

TR0102010193

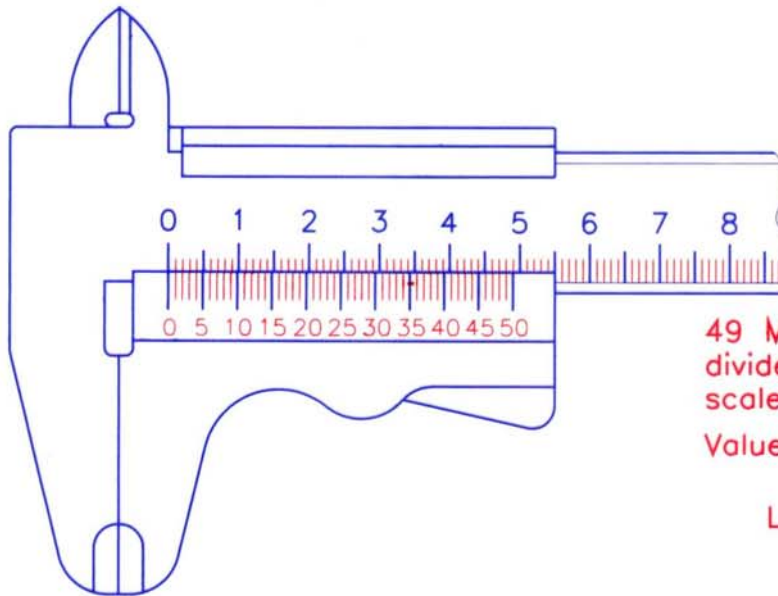

49 Main scale divisions are divided into 50 vernier scale divisions

$$\text{Value of 1 VSD} = \frac{49}{50} \text{ mm}$$

$$\text{Least count} = 1 \text{ MD} - 1 \text{ VSD}$$

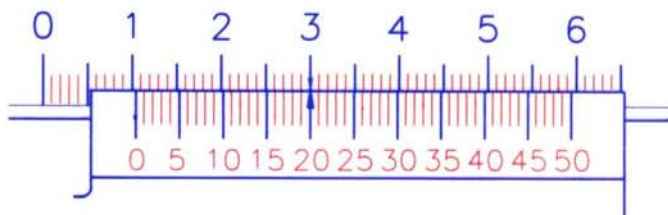

Main scale reading =

Value of coinciding vernier division } =

Reading =

Assignments:-

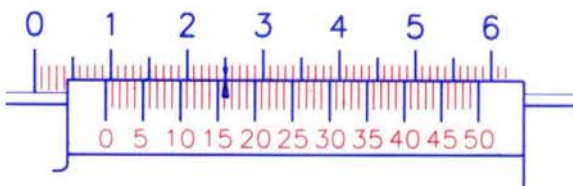

A Reading

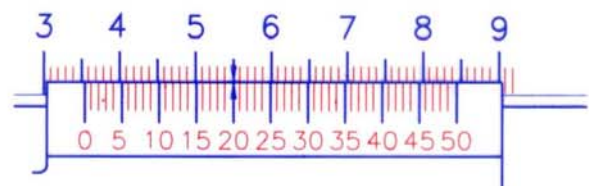

B Reading

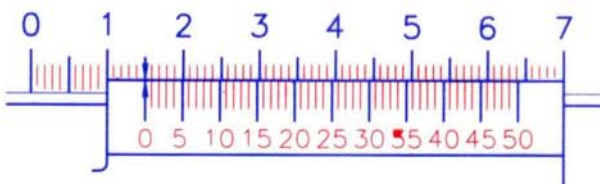

C Reading

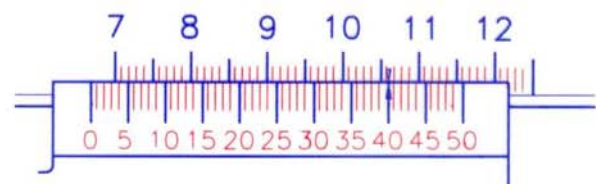

D Reading

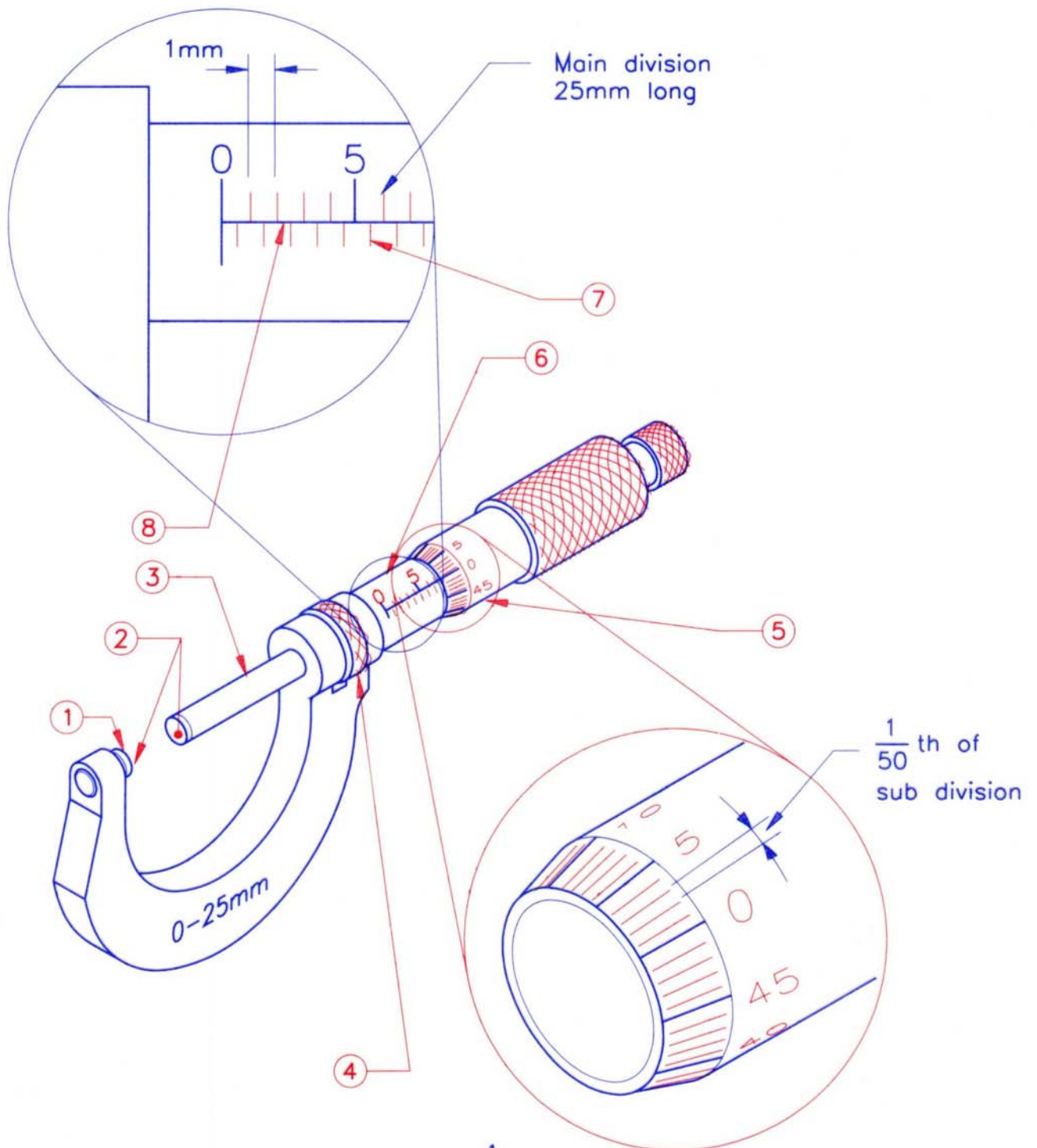

$$\begin{aligned} \text{Least count} &= \frac{1}{50} \text{ th of } 0.5 \\ &= \boxed{} \end{aligned}$$

**MICROMETER
PARTS AND GRADUATIONS**

TR0102020193

CIMI CENTRAL INSTRUCTIONAL
MEDIA INSTITUTE, MADRAS
AN INDO-GERMAN PROJECT

Micrometer graduations

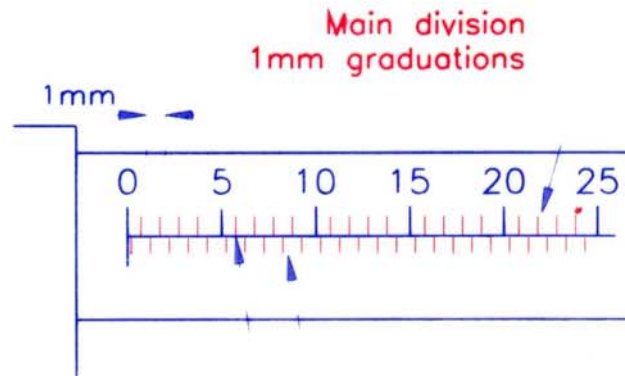

Datum line

Main division
1mm graduations

Sub division
0.5mm graduations

0.5mm - one rotation of thimble-
graduated into 50 parts

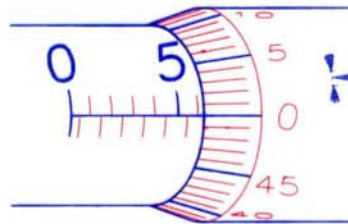

$\frac{1}{50}$ th of 0.5
= 0.01

Thimble divisions
0.01mm graduations

Micrometer reading

Main divisions
 $2 \times 1\text{mm} = 2.00\text{mm}$

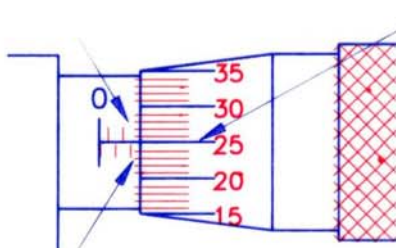

Thimble divisions
 $25 \times 0.1\text{mm}$
= 0.25mm

Sub division
 $1 \times 0.5\text{mm}$
= 0.5mm

Main divisions =
Sub division =
Thimble divisions =
Reading =

Example

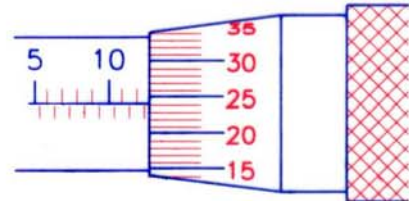

Main divisions =
Sub division =
Thimble divisions =
Reading =

Assignments:-

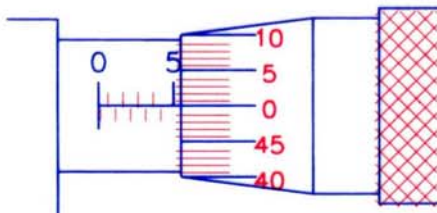

A Reading

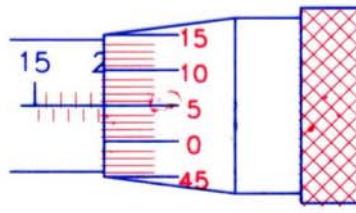

B Reading

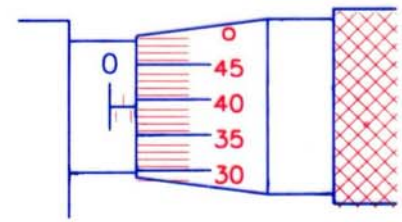

C Reading

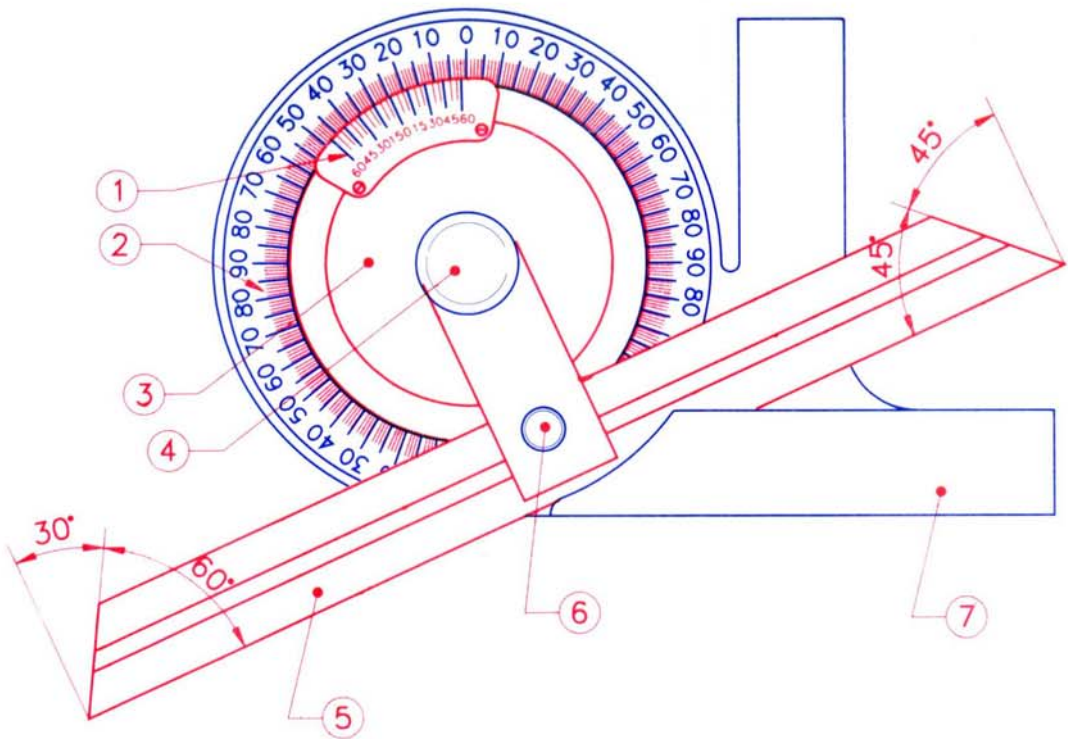

Applications:-

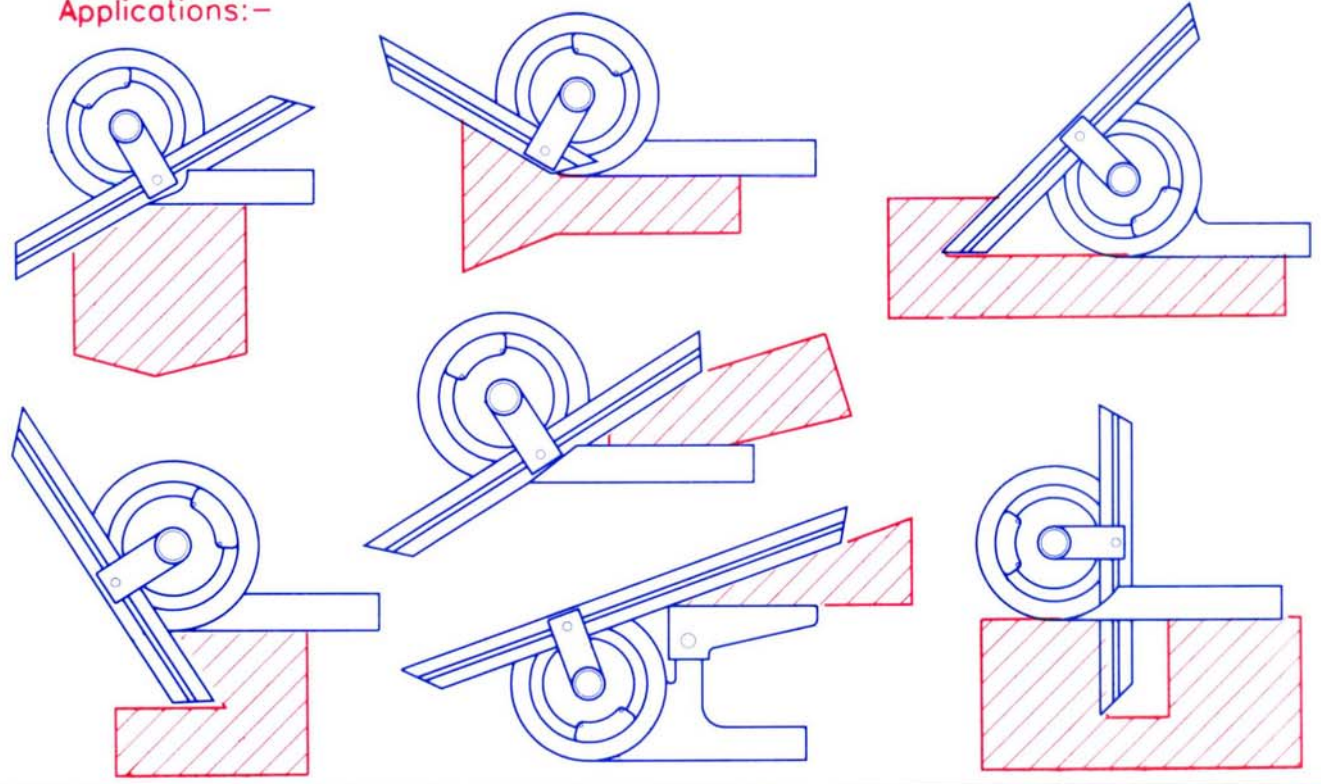

**VERNIER BEVEL PROTRACTOR
PARTS & APPLICATION**

TR0102030193

CIM CENTRAL INSTRUCTIONAL
MEDIA INSTITUTE, MADRAS
AN INDO-GERMAN PROJECT

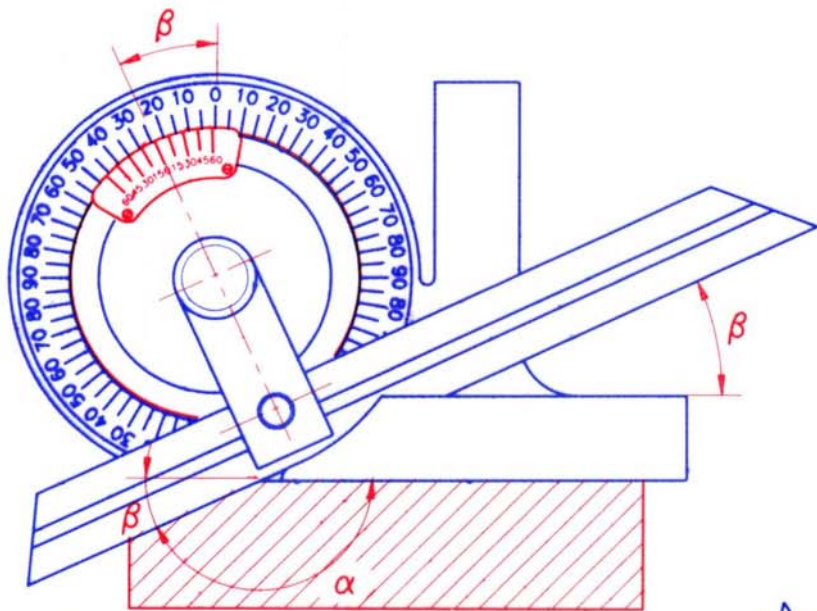

Obtuse angle
 $\alpha = 180^\circ - \beta$

Assignments:-

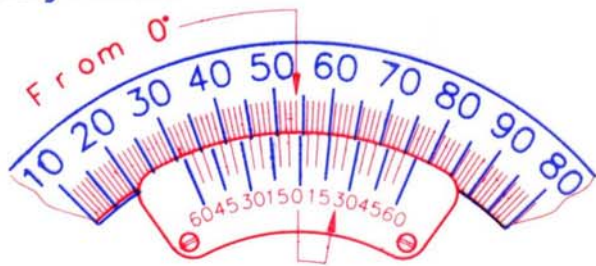

A Reading

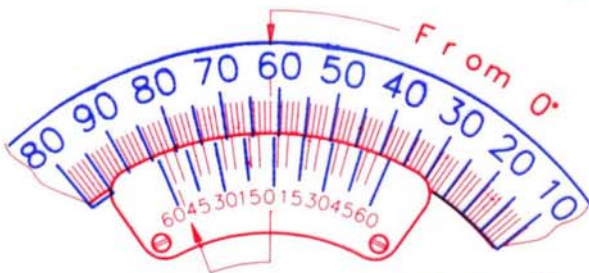
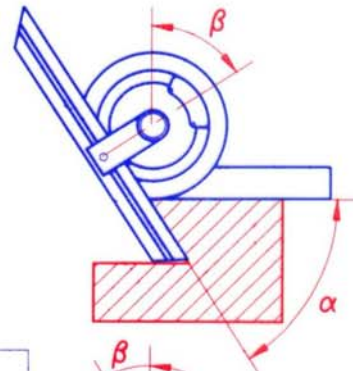

B Reading

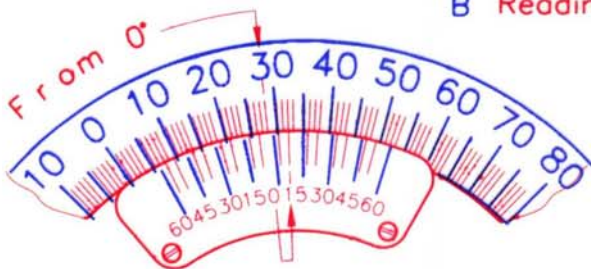
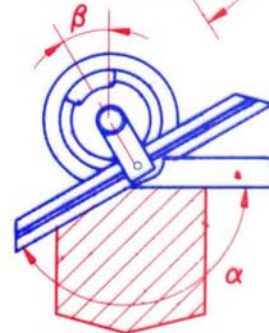

C Reading



D Reading

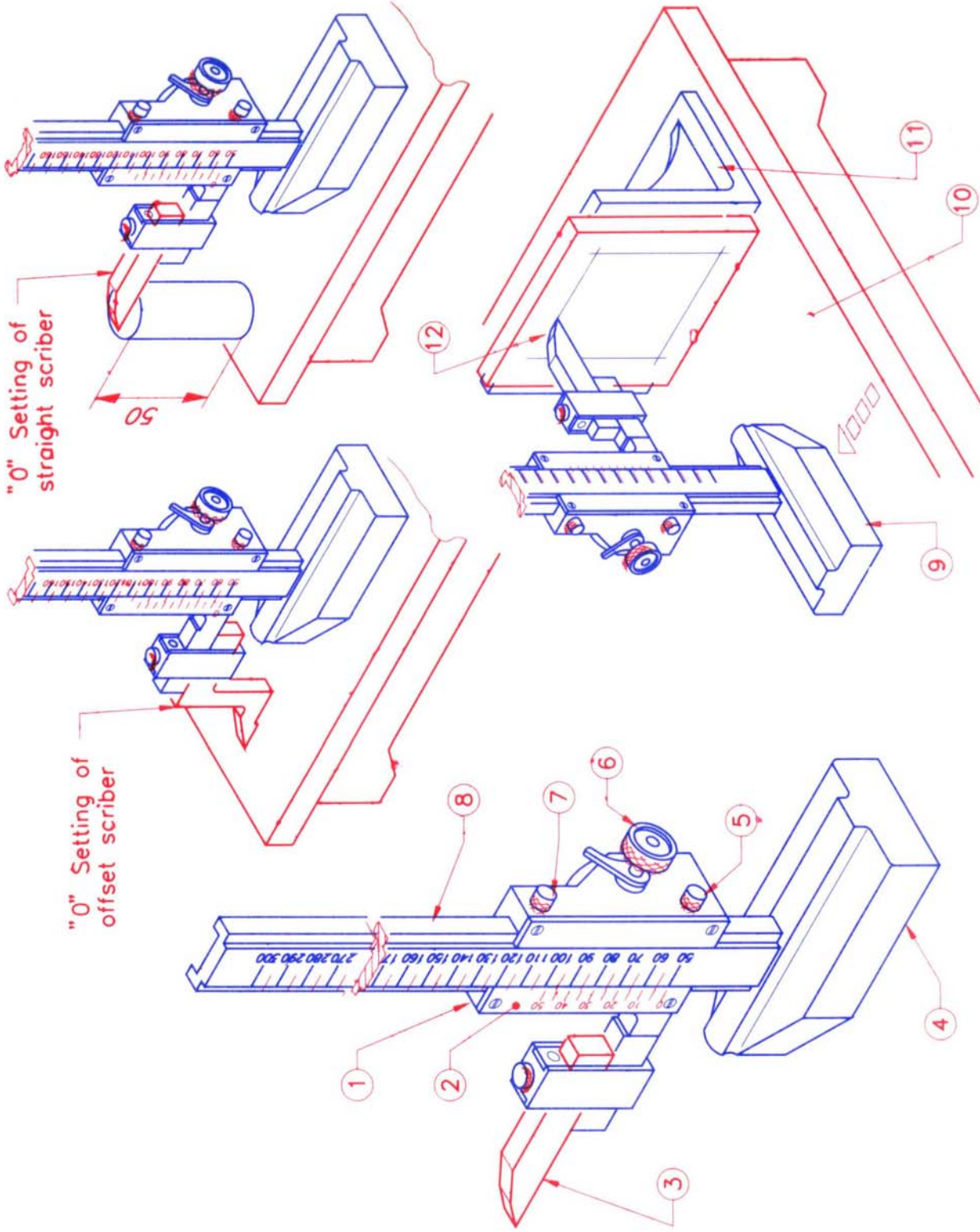

VERNIER HEIGHT GAUGE

TR0102040193

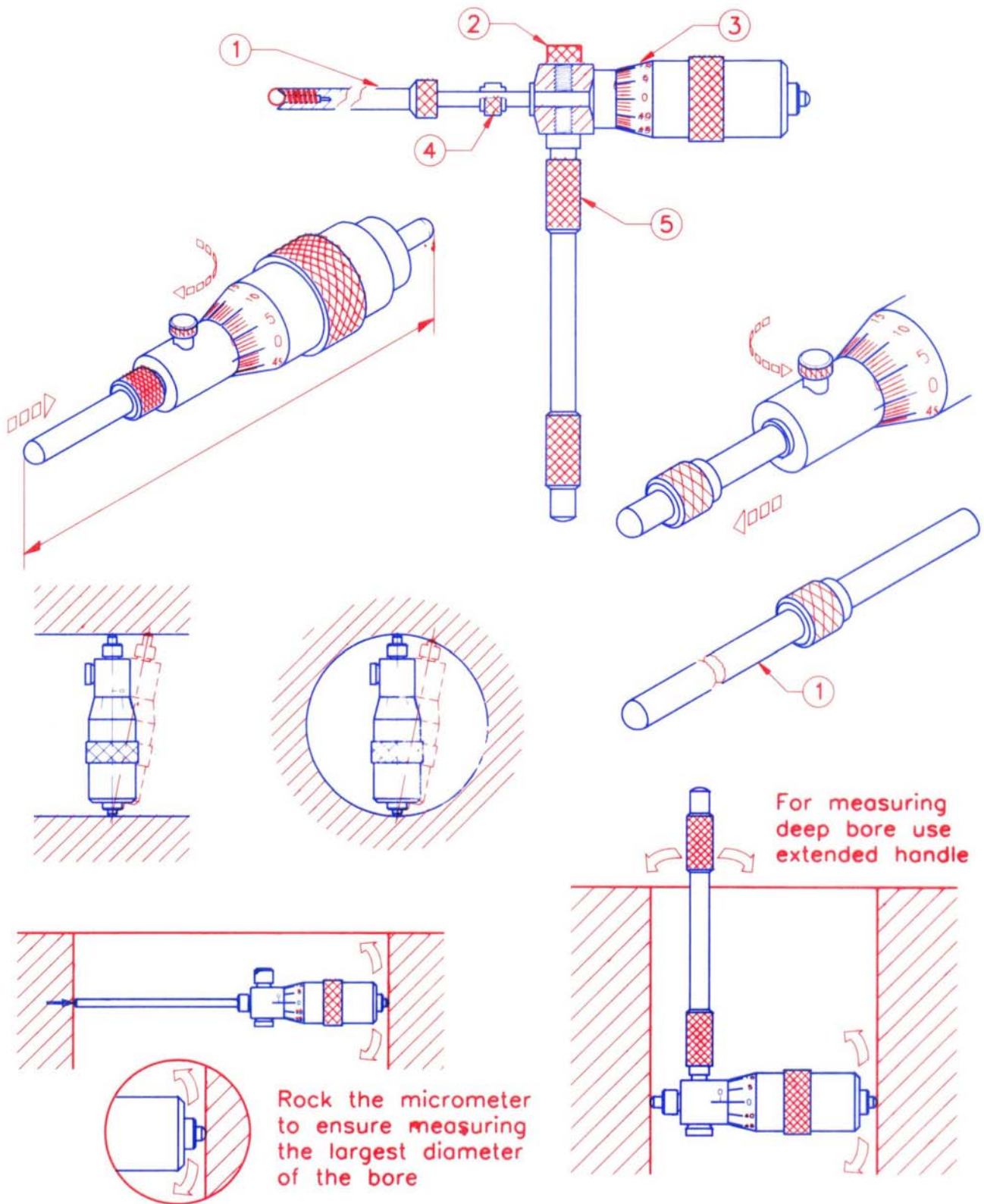

INSIDE MICROMETER

TR0102050193

CIMI CENTRAL INSTRUCTIONAL
 MEDIA INSTITUTE, MADRAS
 AN INDO-GERMAN PROJECT

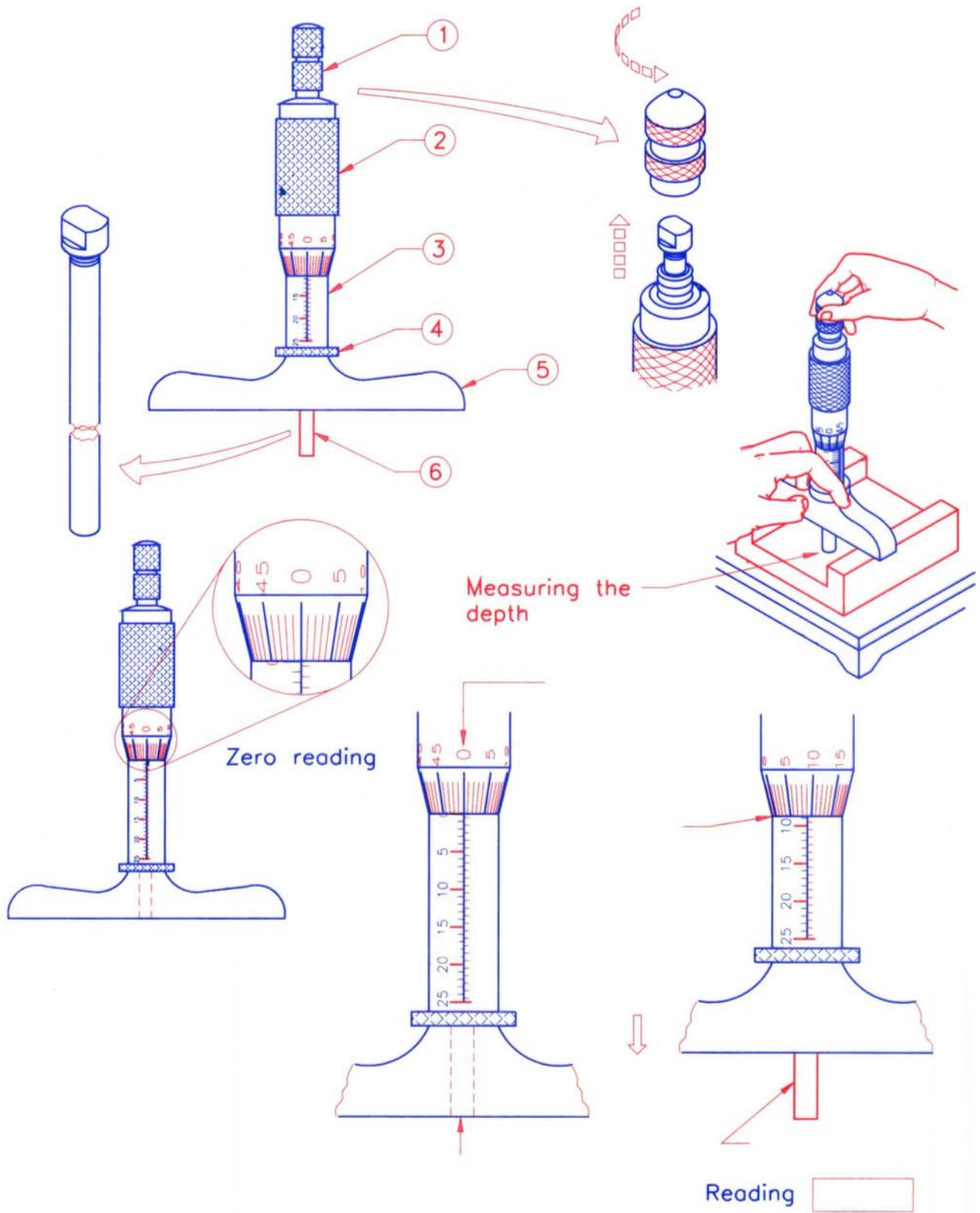

DEPTH MICROMETER

TR0102060193

51-A-46-H-5-V-8

Type of abrasive

A - Aluminium oxide
C - Silicon carbide

51-A-46-H-5-V-8

Grain size : (grit)
The actual size of the abrasive grain

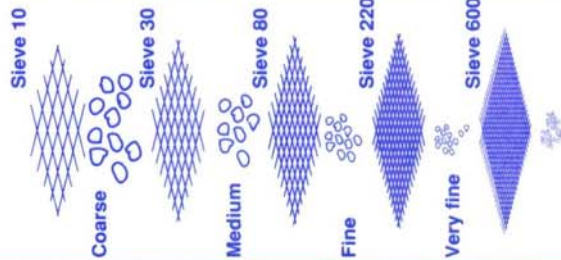

51-A-46-H-5-V-8

Grade :
The strength of the bond holds the grain in position

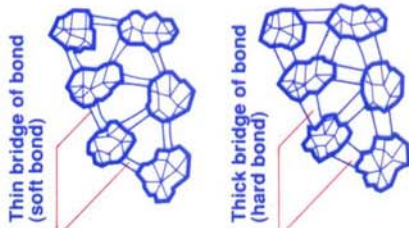

51-A-46-H-5-V-8

Structure :
The amount of bond present between the abrasive grains.

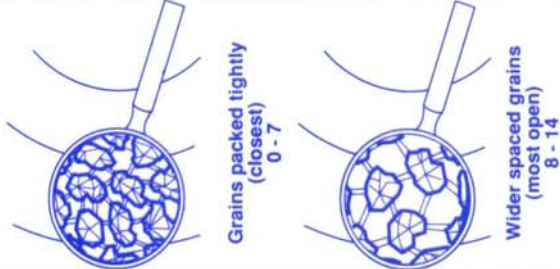

51-A-46-H-5-V-8

Type of bond

V - Vitrified
S - Silicate
R - Rubber
RF - Rubber reinforced
B - Resinoid (Synthetic resins)
BF - Resinoid reinforced
E - Shellac
Mg - Magnesia

51-A-46-H-5-V-8

Manufacturer's symbol for abrasive (Optional)

51-A-46-H-5-V-8

Manufacturer's own identification mark for the wheel (Optional)

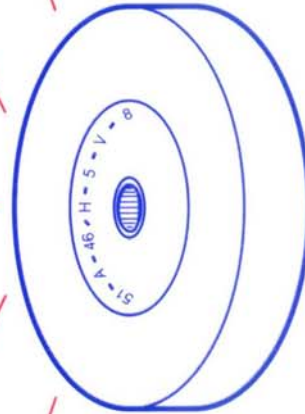

GRINDING WHEEL MARKING

TR0104010193

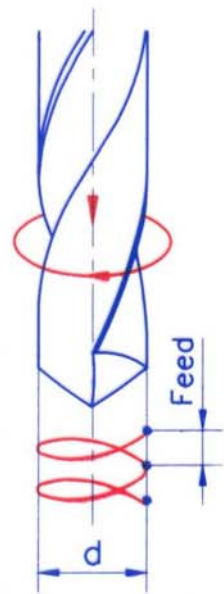
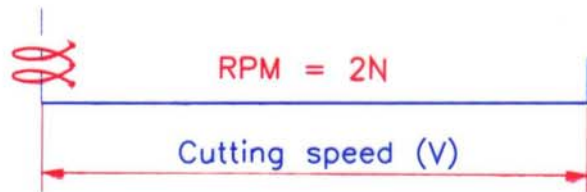
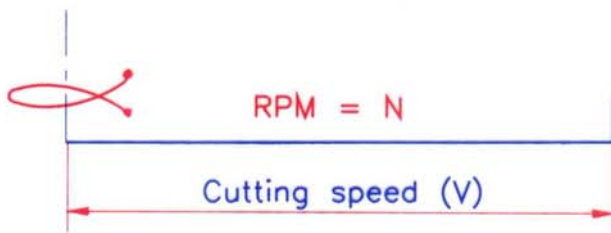
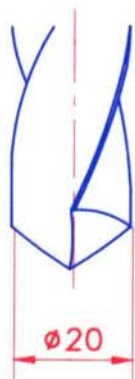
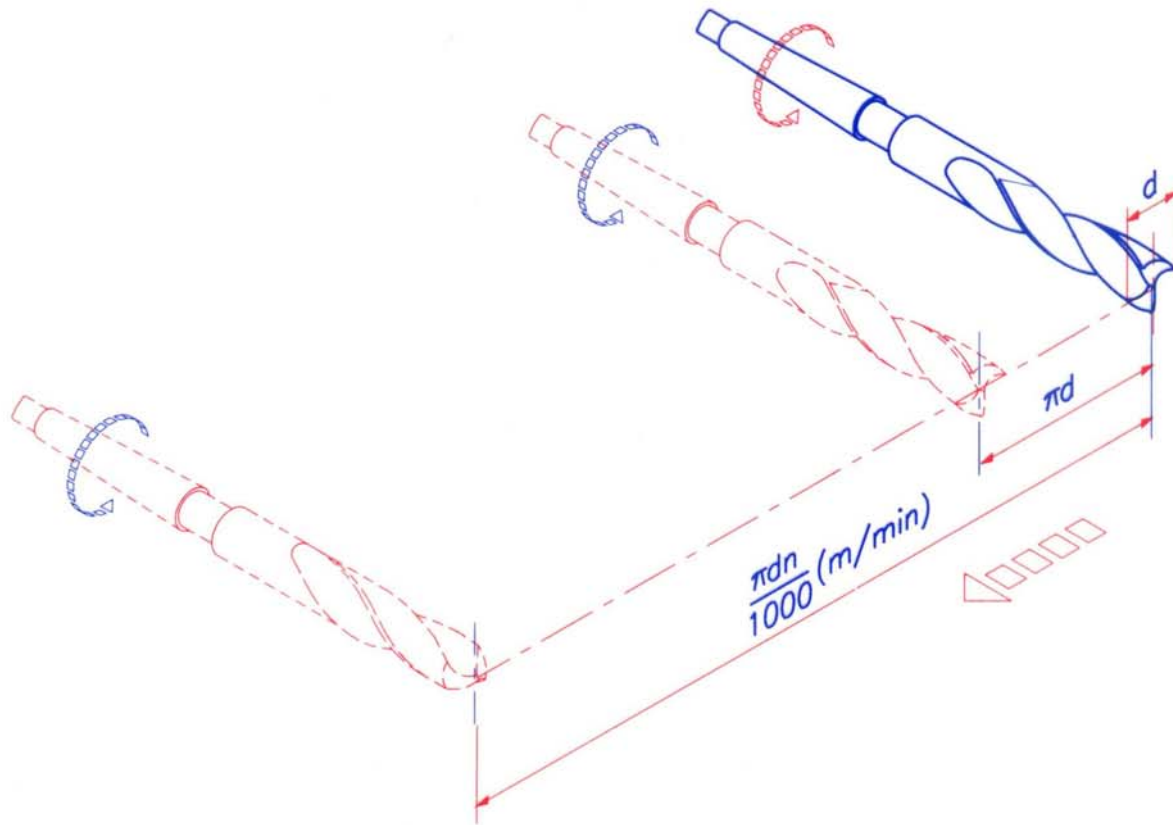

CUTTING SPEED, FEED AND R.P.M. OF DRILLS

TR0105010193

CIMI CENTRAL INSTRUCTIONAL
MEDIA INSTITUTE, MADRAS
AN INDO-GERMAN PROJECT

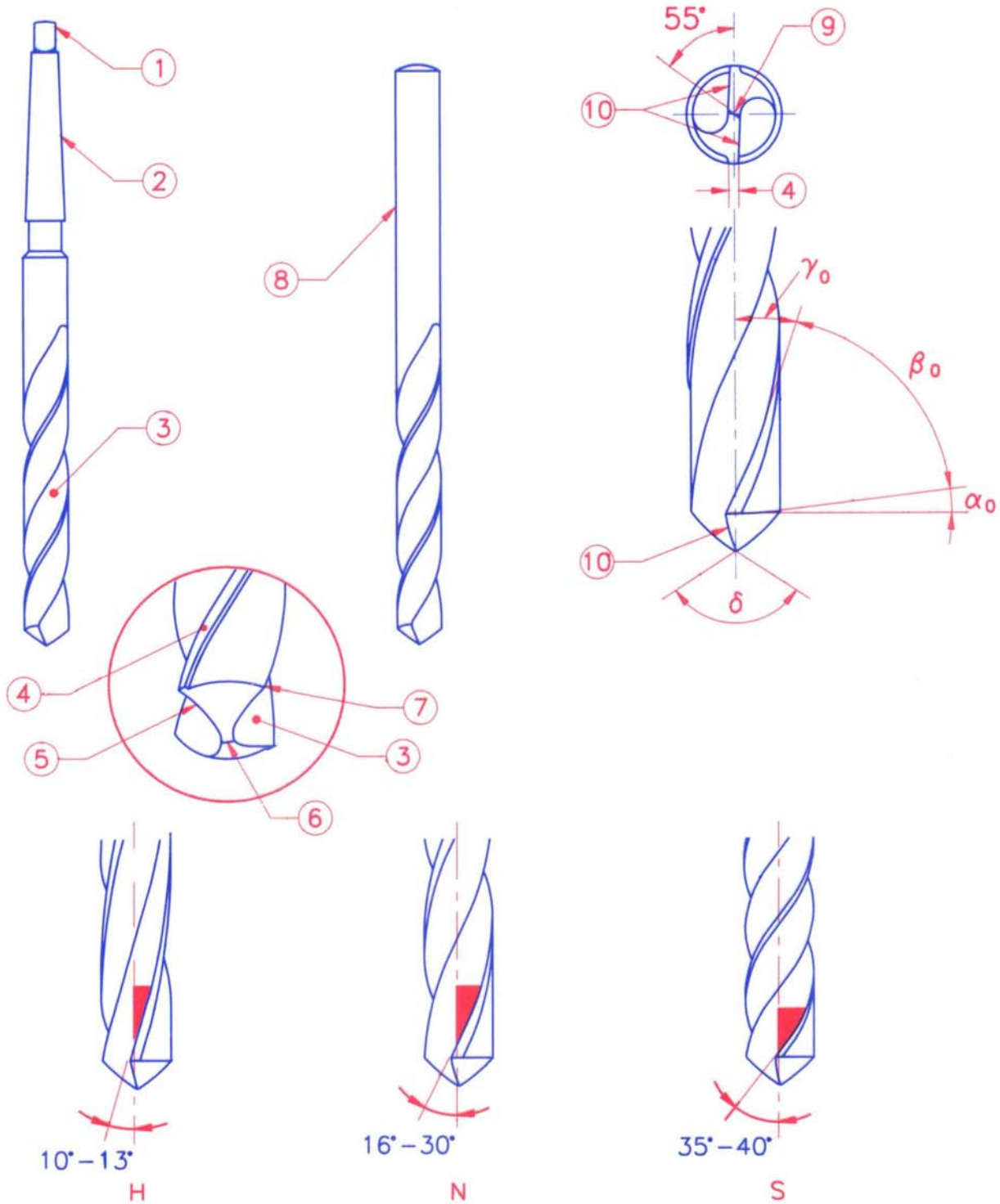

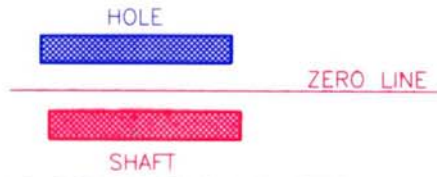

SIMPLIFIED SCHEMATIC DIAGRAM OF CLEARANCE FIT

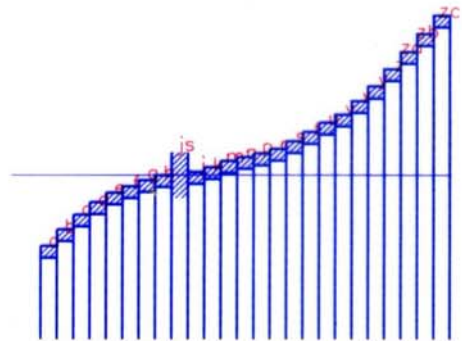
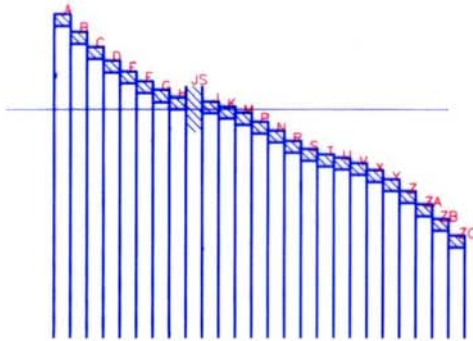
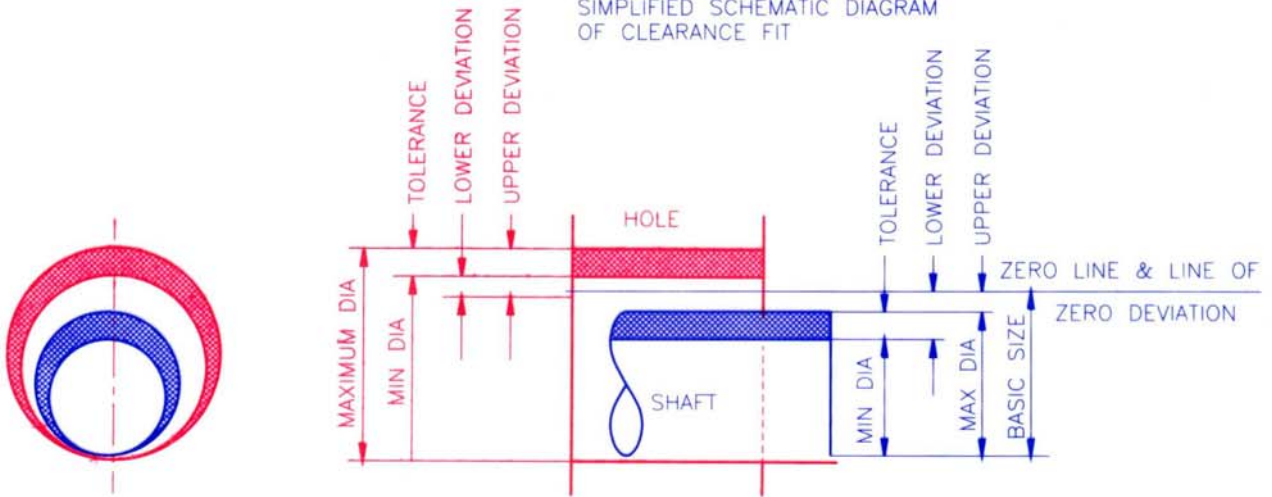

18 GRADES OF TOLERANCES

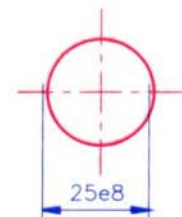
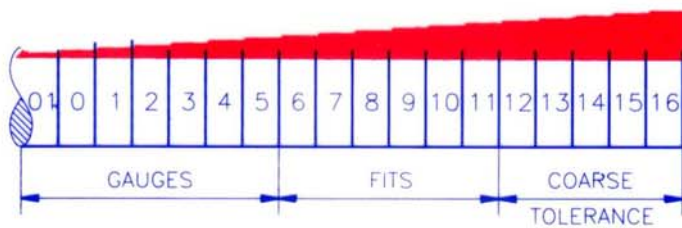
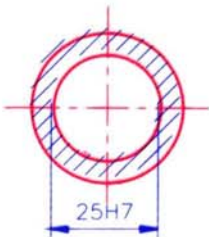

• WHAT DOES 25H7 INDICATE?

• WHAT DOES 25e8 INDICATE?

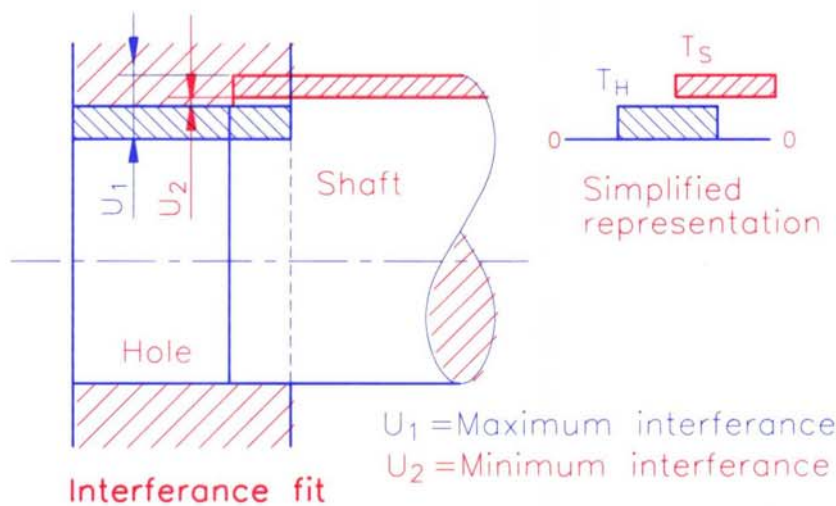
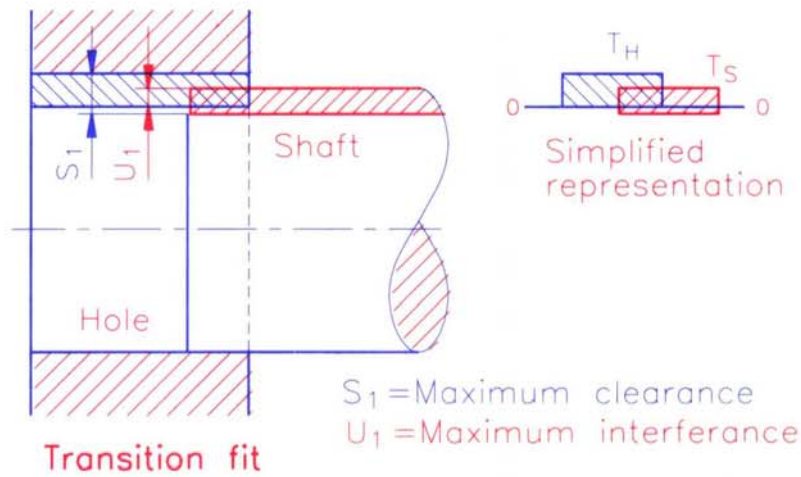
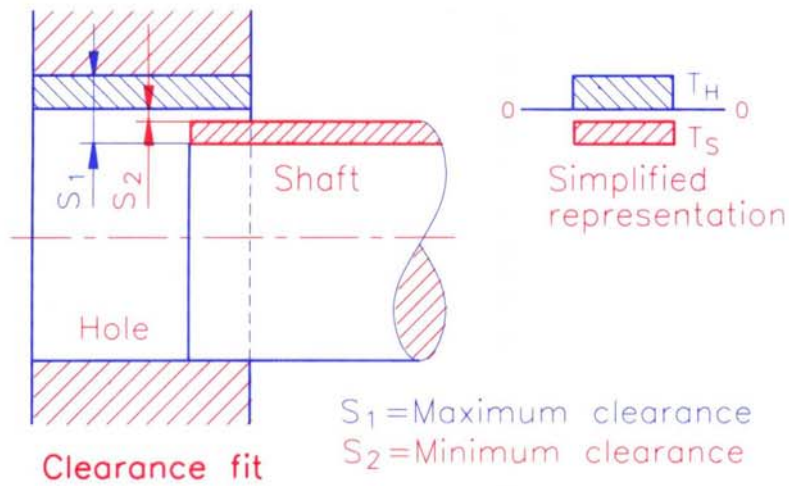

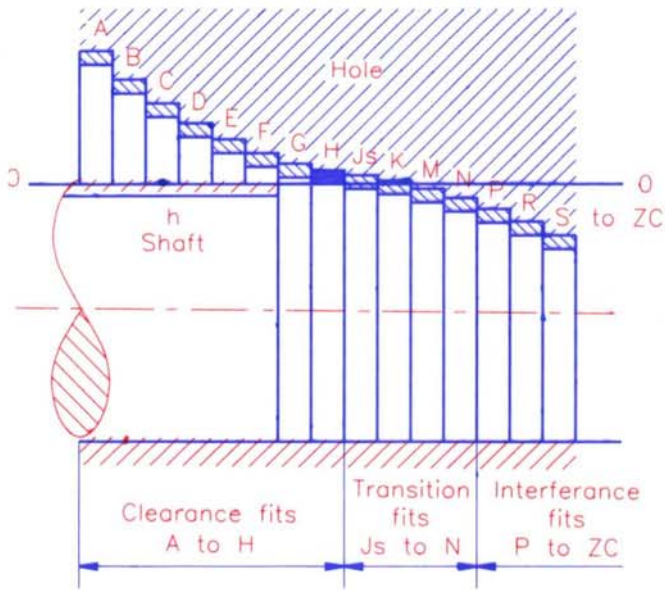

BASIC SHAFT SYSTEM

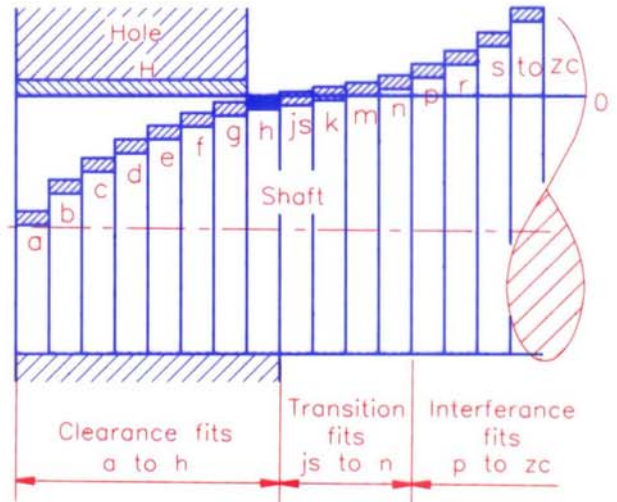

BASIC HOLE SYSTEM

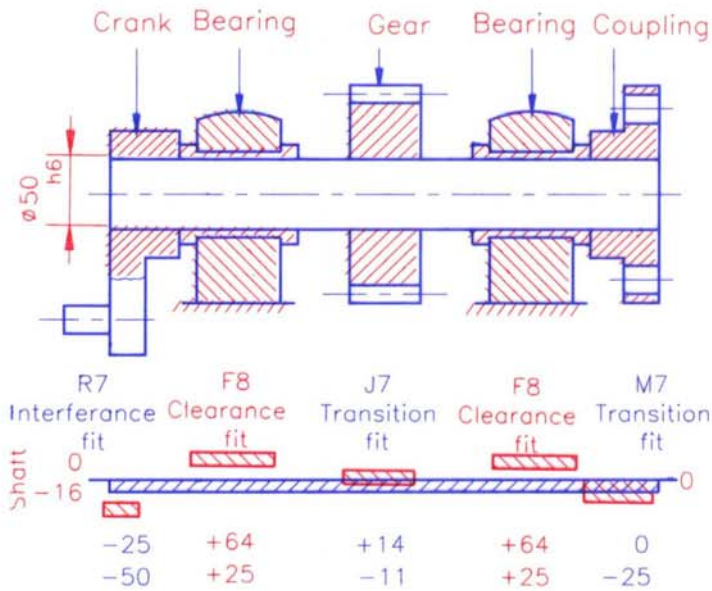

APPLICATION FOR THE BASIC SHAFT SYSTEM

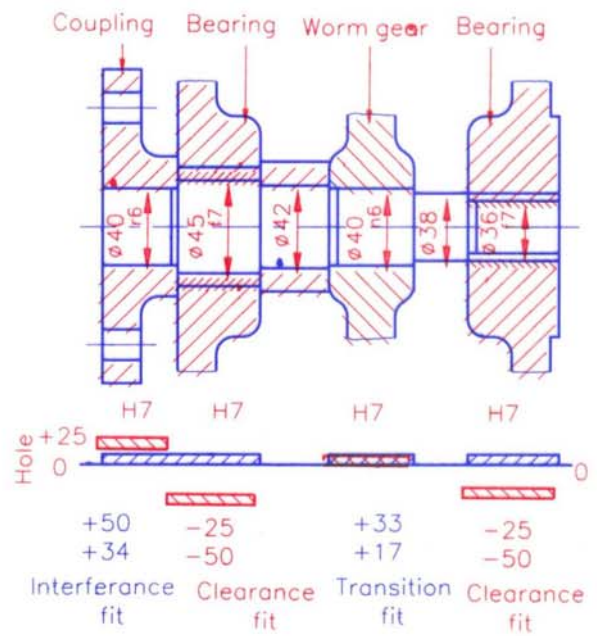

APPLICATION FOR THE BASIC HOLE SYSTEM

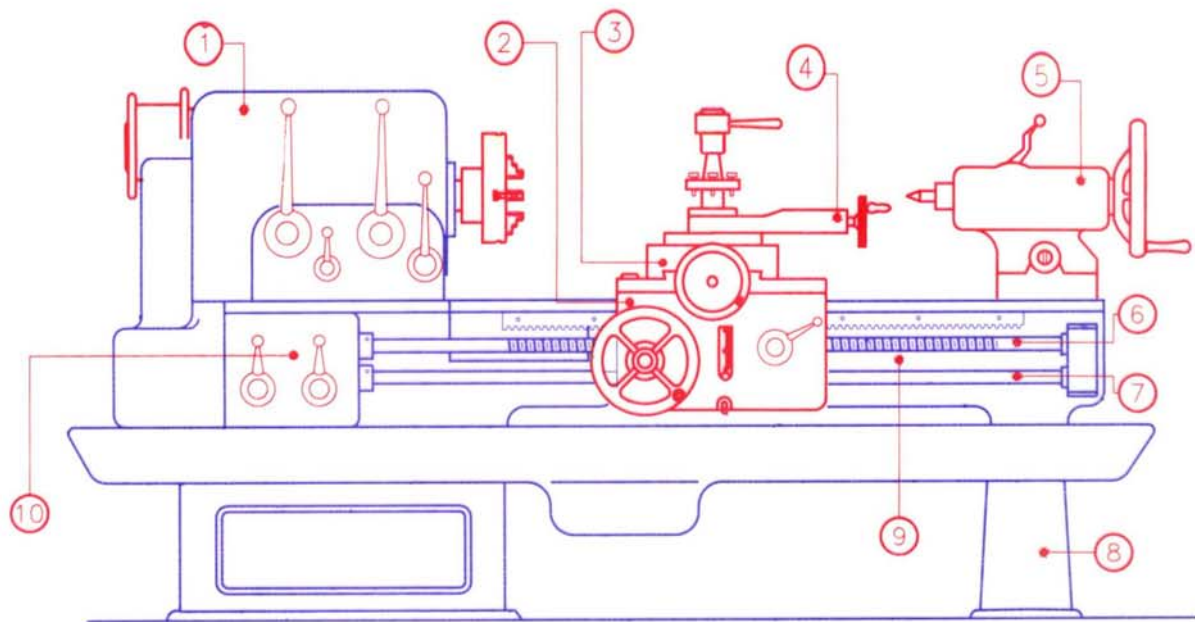

CENTRE LATHE

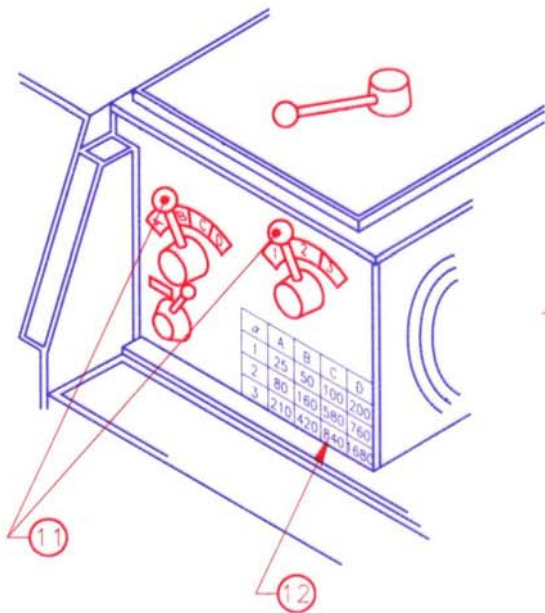

HEAD STOCK

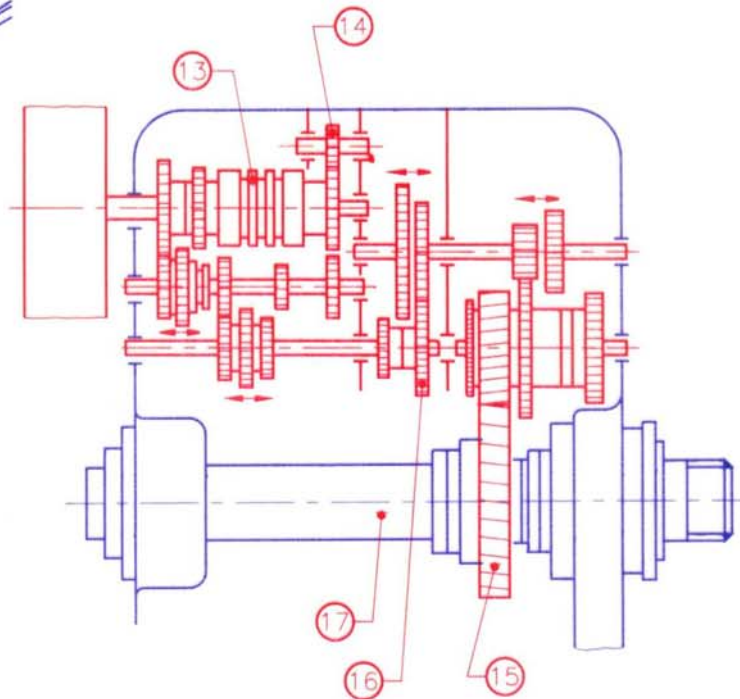

INNER MECHANISM

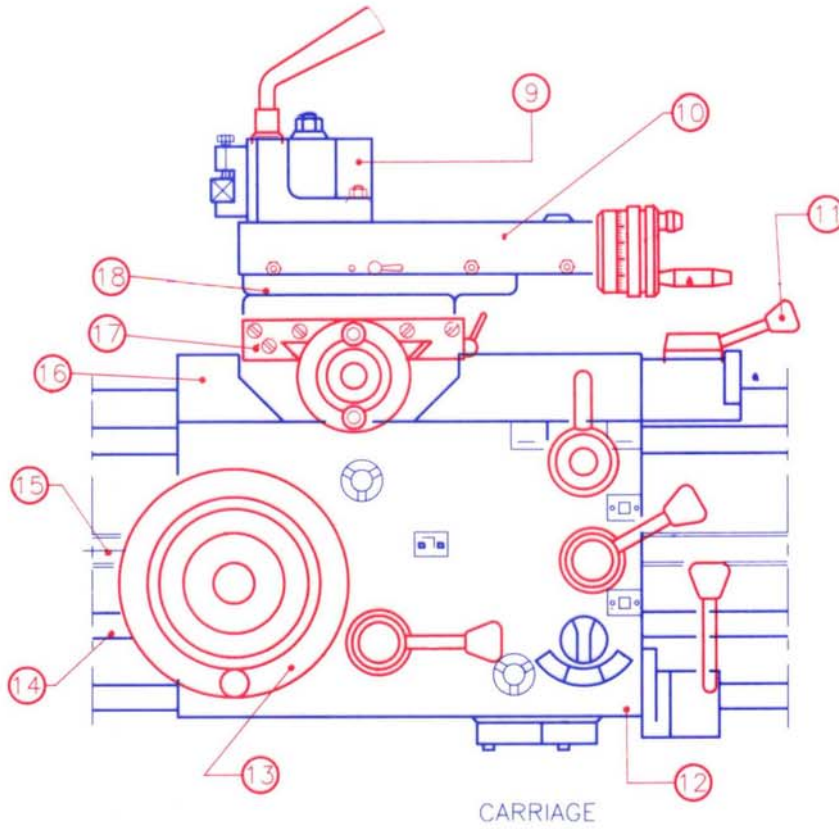
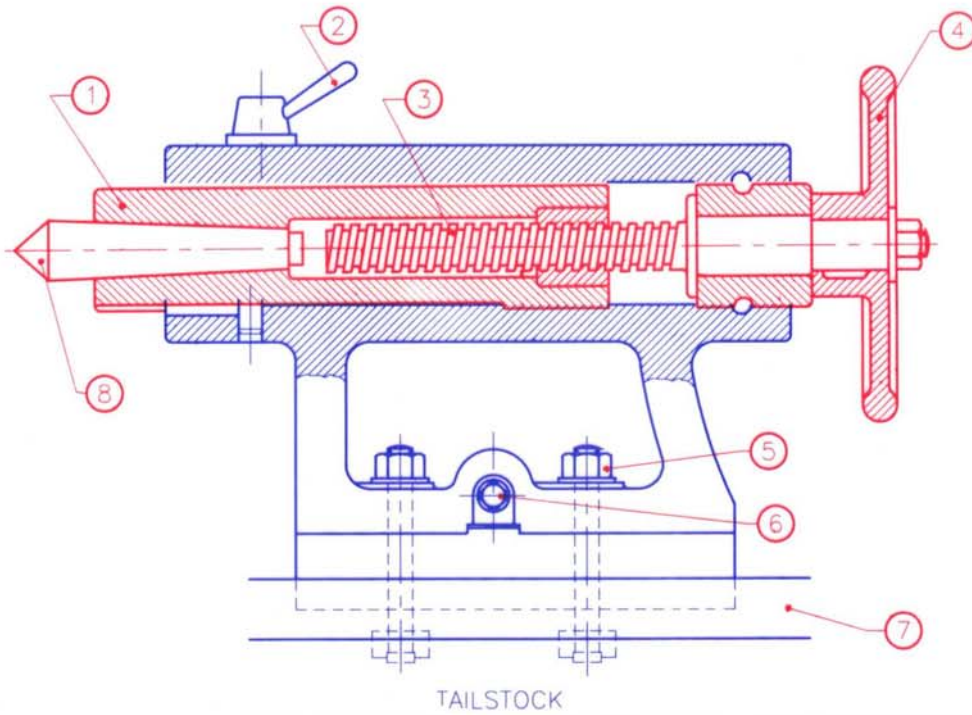

LATHE PARTS

TR01 1201 0293

CIMI CENTRAL INSTRUCTIONAL
MEDIA INSTITUTE, MADRAS
AN INDO-GERMAN PROJECT

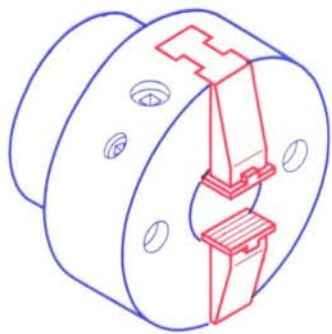

TWO JAW CHUCK

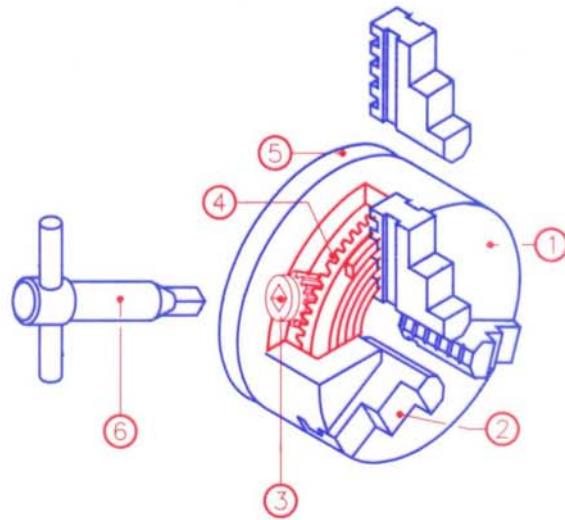

THREE JAW CHUCK

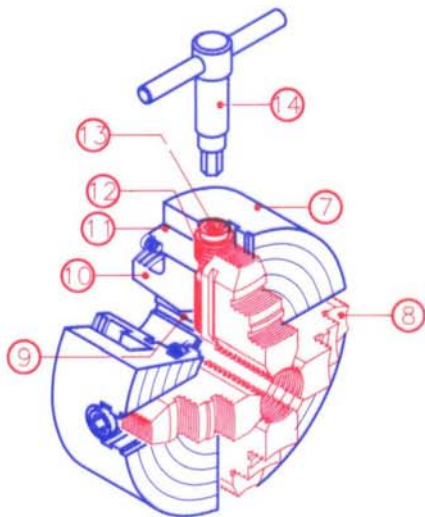

FOUR JAW CHUCK

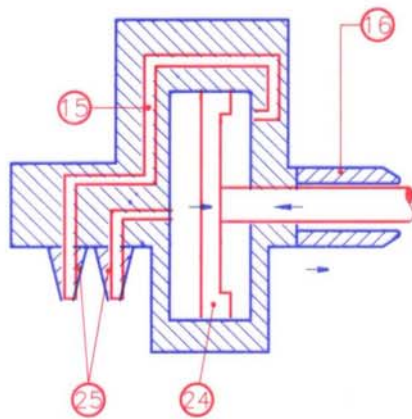

HYDRAULIC CHUCK

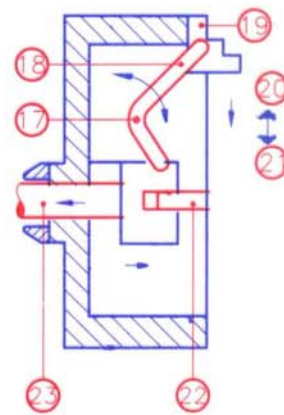

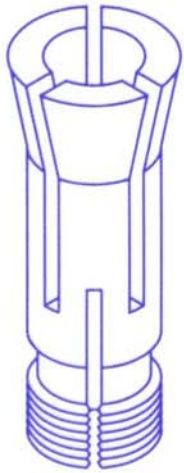

①

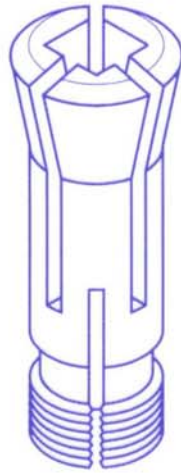

②

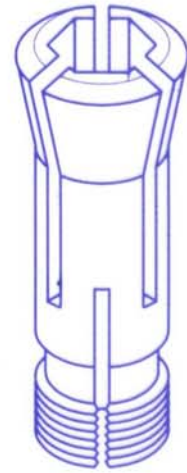

③

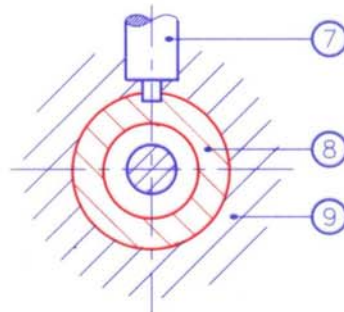
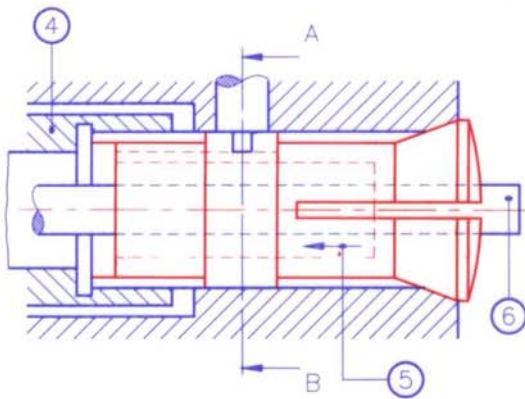

COLLET CHUCKS

TR01 1301 0293

CIM CENTRAL INSTRUCTIONAL
MEDIA INSTITUTE, MADRAS
AN INDO-GERMAN PROJECT

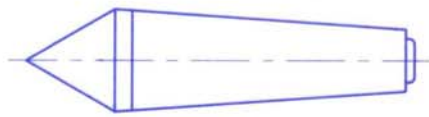

1

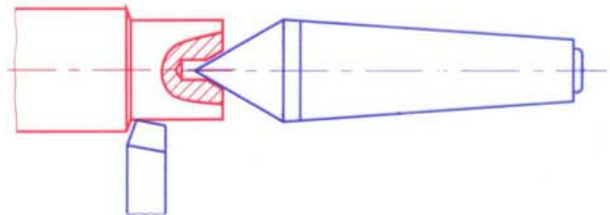

5

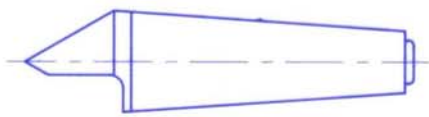

2

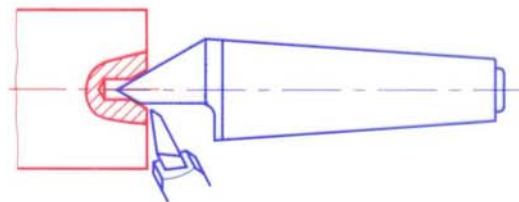

6

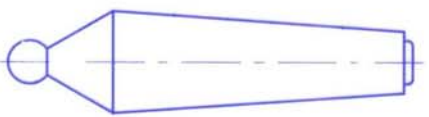

3

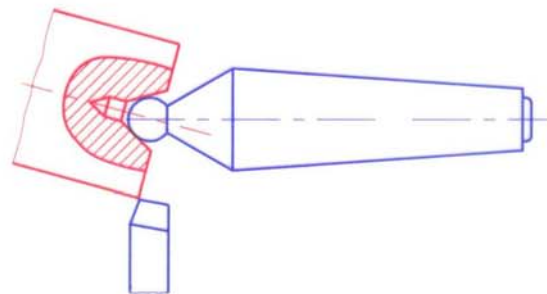

7

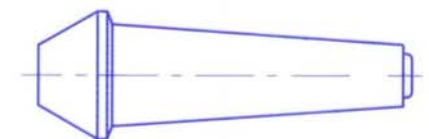

4

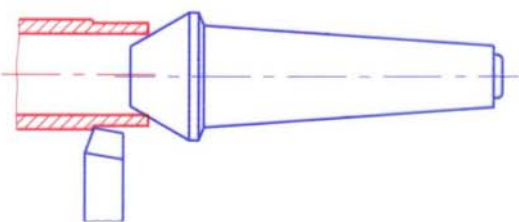

8

LATHE CENTRES AND THEIR APPLICATION

TR01 13020193

CIM CENTRAL INSTRUCTIONAL
MEDIA INSTITUTE, MADRAS
AN INDO-GERMAN PROJECT

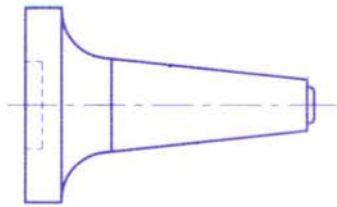

PAD CENTRE

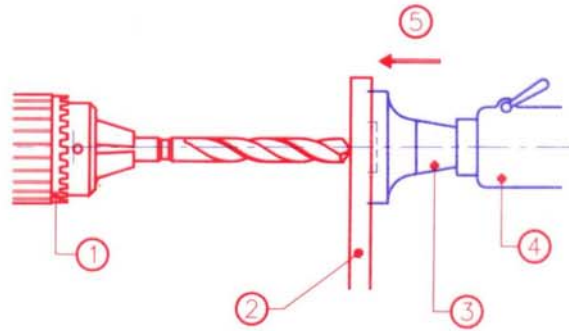

APPLICATION OF PAD CENTRE

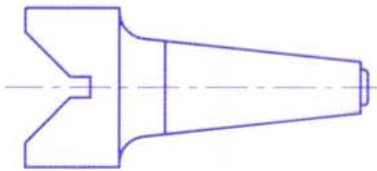

CROACH OR SWIVEL 'V' CENTRE

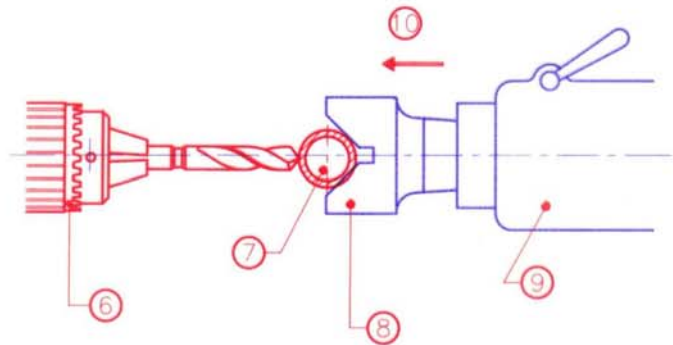

APPLICATION OF CROACH CENTRE

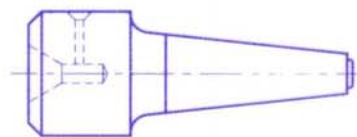

FEMALE CENTRE

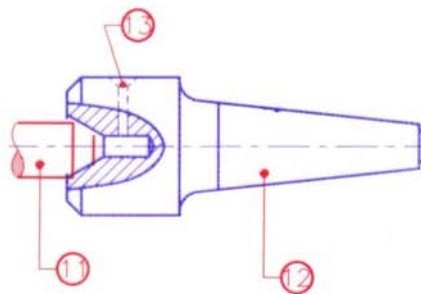

APPLICATION OF FEMALE CENTRE

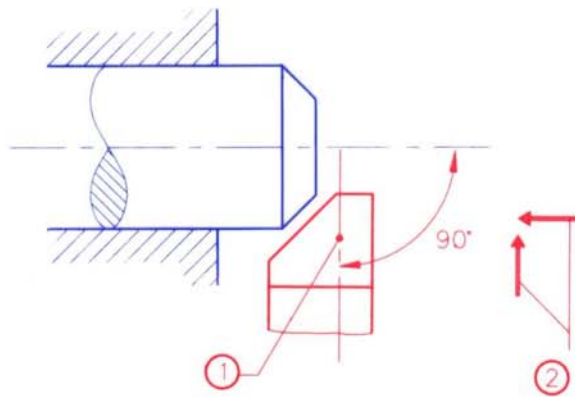

FORM TOOL METHOD

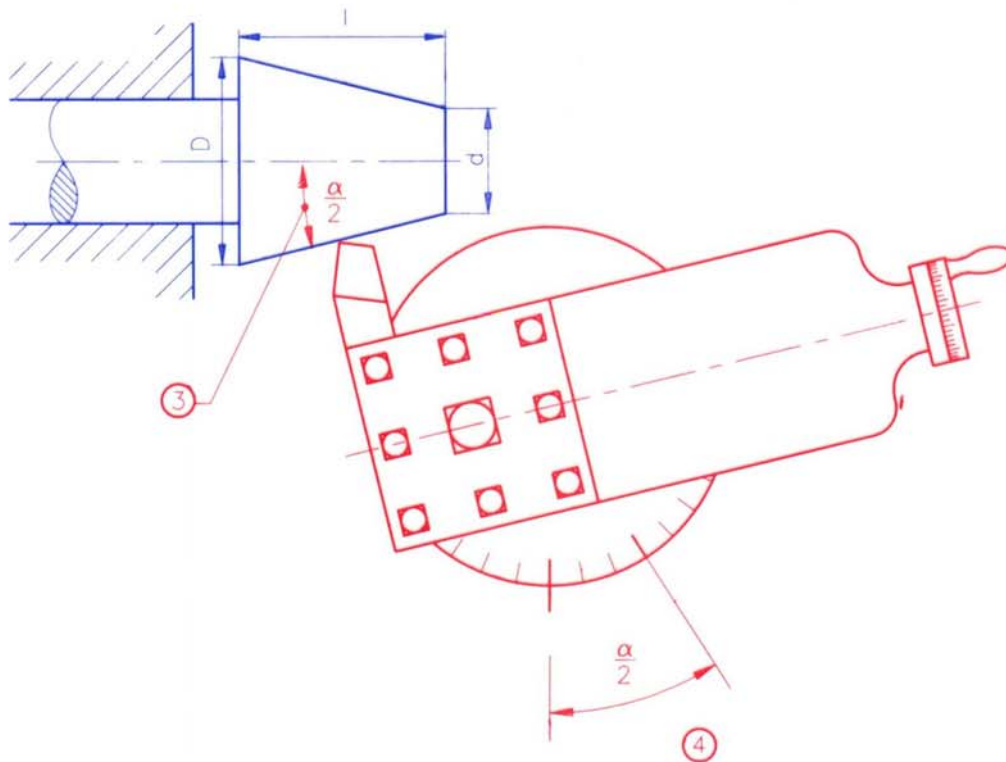

COMPOUND SLIDE METHOD

**DIFFERENT METHODS OF
TAPER TURNING**
(FORM TOOL AND COMPOUND REST)

TR01 15030193

CIMI CENTRAL INSTRUCTIONAL
MEDIA INSTITUTE, MADRAS
AN INDO-GERMAN PROJECT

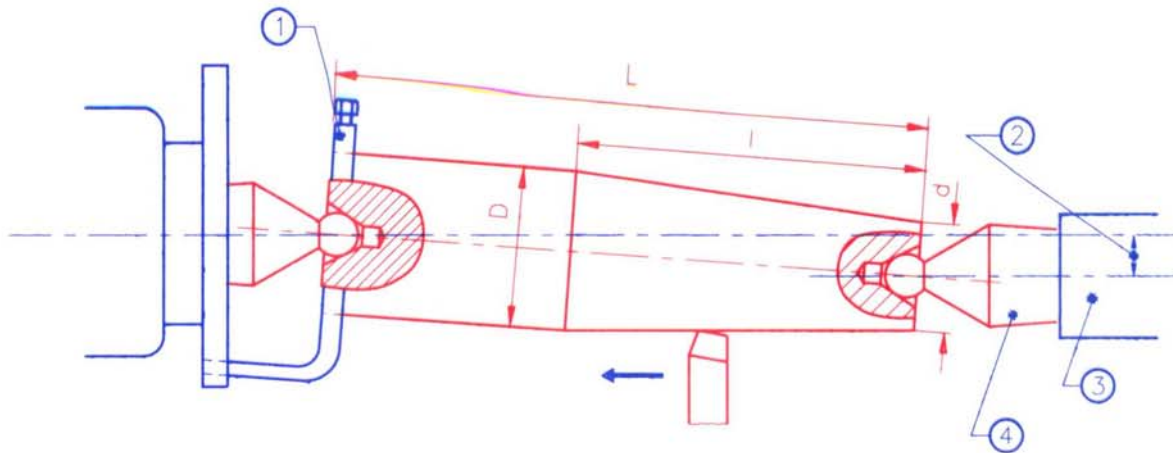

TAILSTOCK OFFSET METHOD

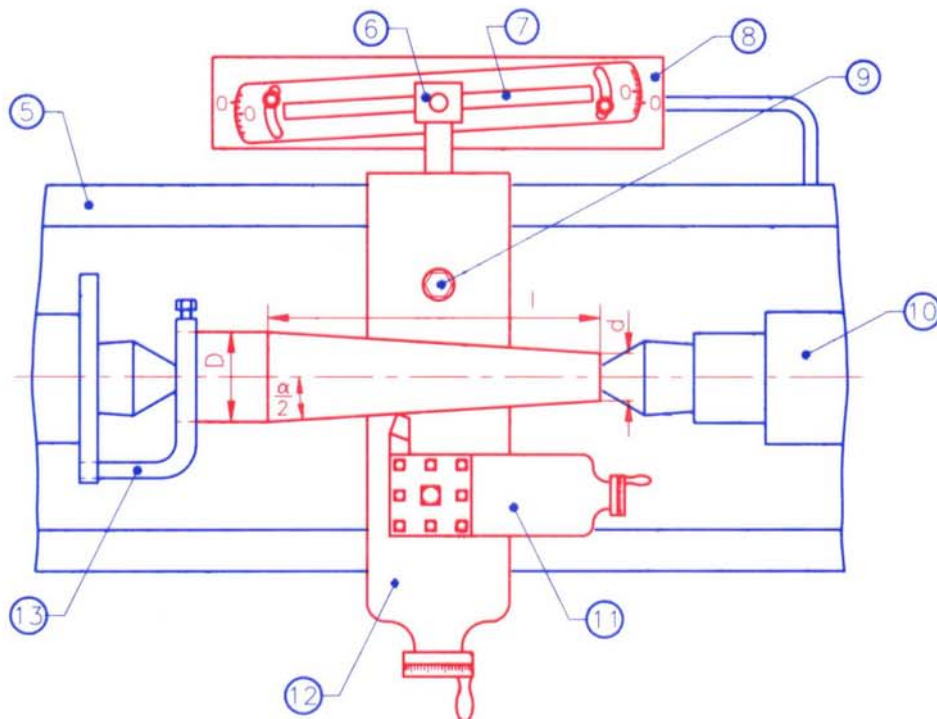

TAPER TURNING ATTACHMENT METHOD

DIFFERENT METHODS OF TAPER TURNING

(TAILSTOCK SET OVER AND TAPER TURNING ATTACHMENT)

TR01 15 03 02 93

CIM CENTRAL INSTRUCTIONAL
MEDIA INSTITUTE, MADRAS
AN INDO-GERMAN PROJECT

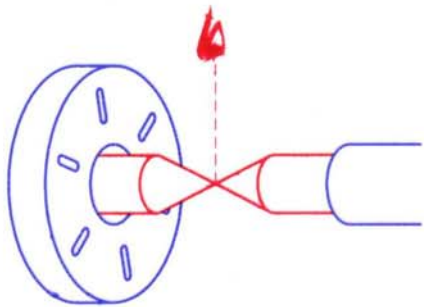

VISUAL ALIGNMENT OF CENTRES

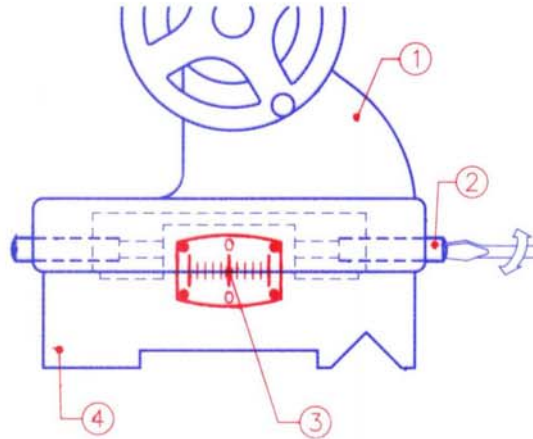

ALIGNMENT OF CENTRES USING GRADUATIONS ON BACK OF TAILSTOCK

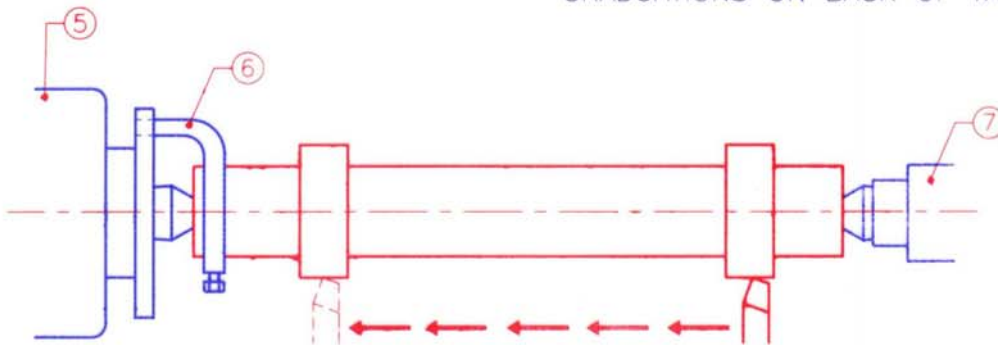

ALIGNMENT OF LATHE CENTRES BY TRAIL CUT METHOD

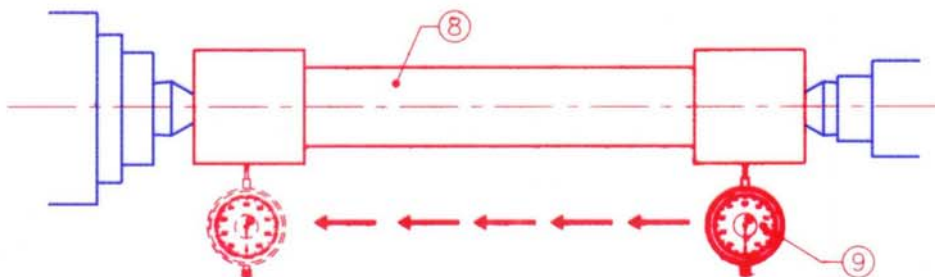

ALIGNING CENTRES WITH A TEST BAR AND DIAL INDICATOR