

# HAND HAMMERS - APPLICATIONS

TR0101010193

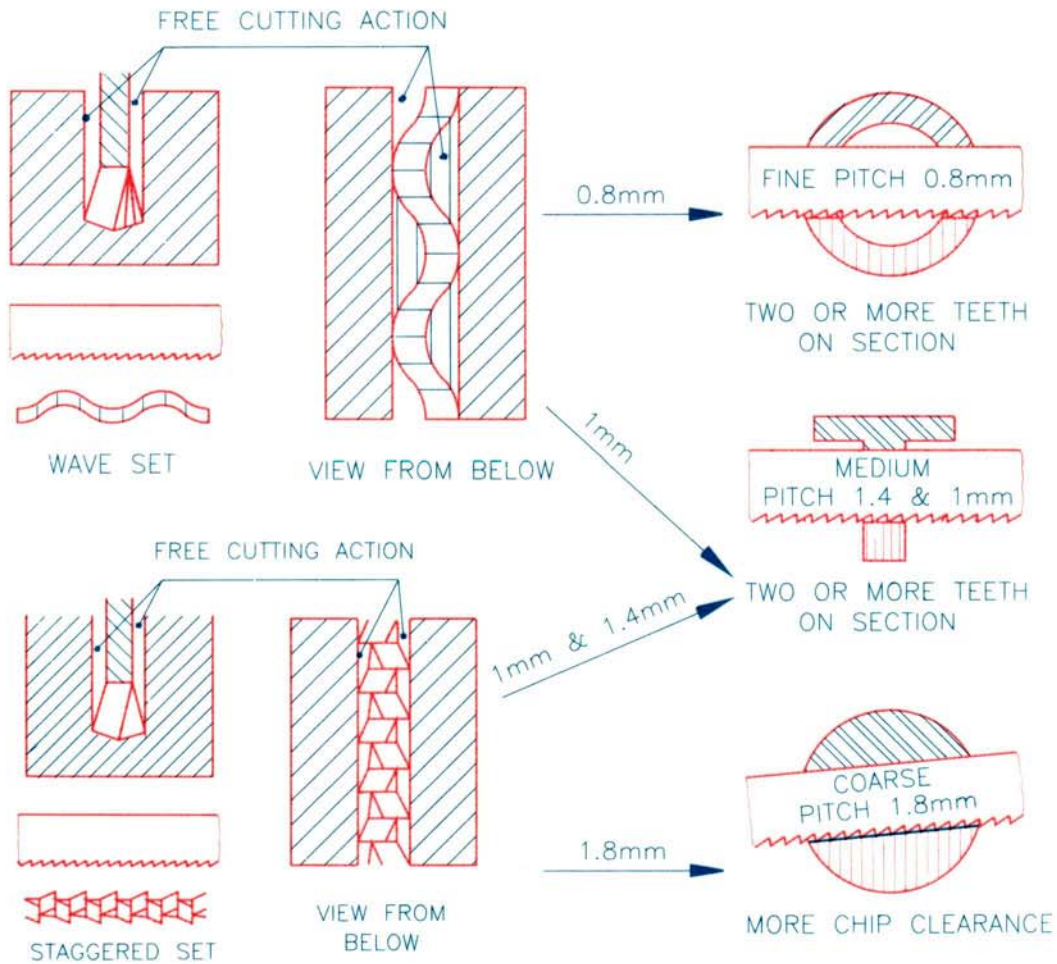
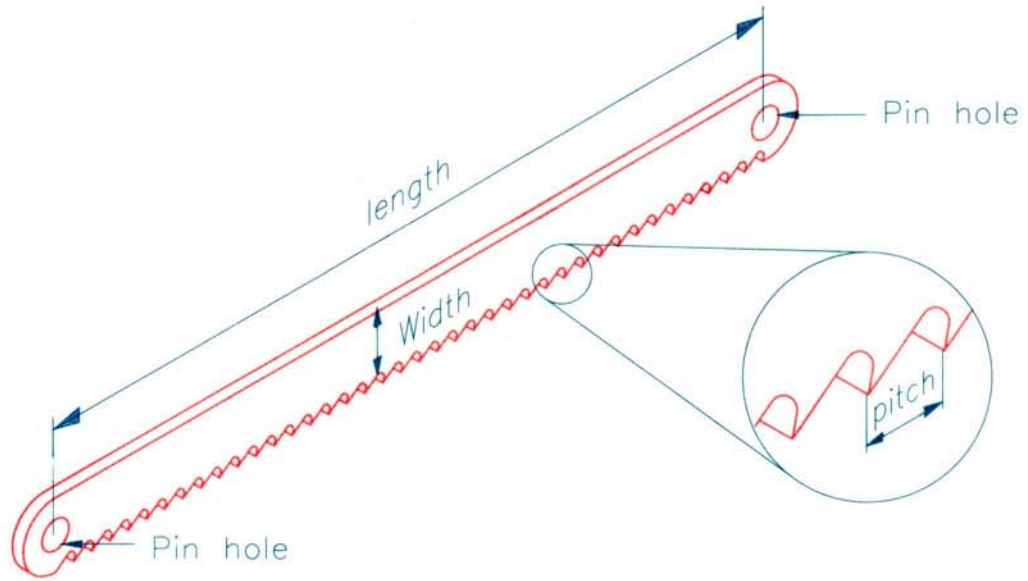

## HACKSAW BLADE – SELECTION

TR0101010293

**CIMI** CENTRAL INSTRUCTIONAL  
MEDIA INSTITUTE, MADRAS  
AN INDO-GERMAN PROJECT

SINGLE CUT

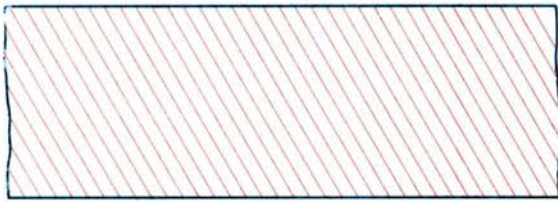

DOUBLE CUT  
UP CUT

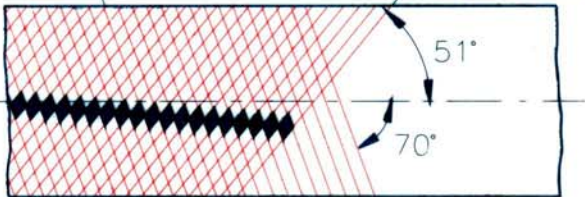

File teeth

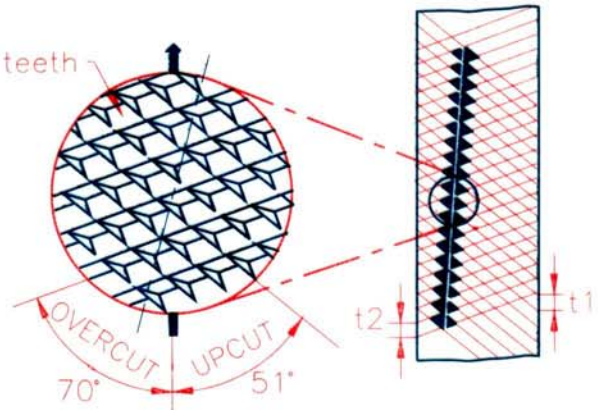

CURVED CUT

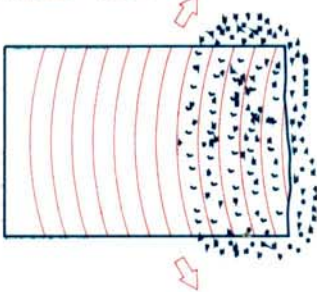

RASP CUT

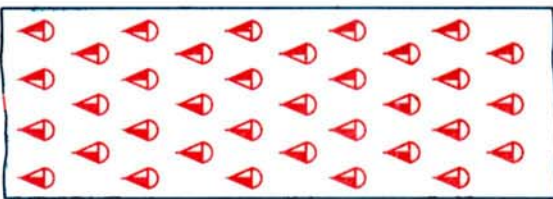

CHISEL CUT

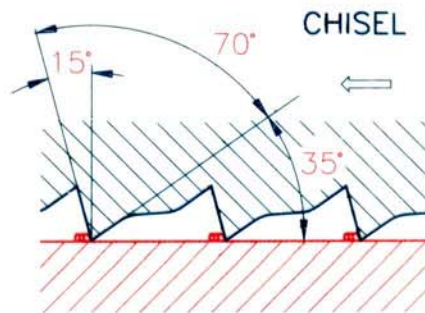

MILL CUT

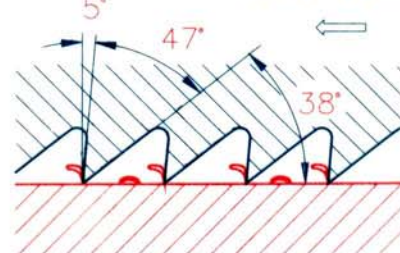

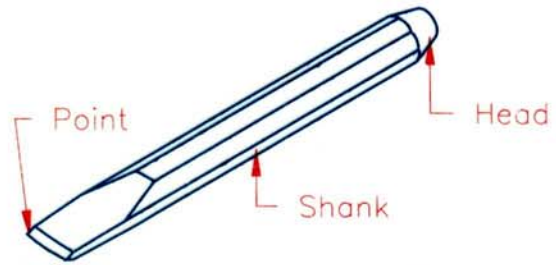
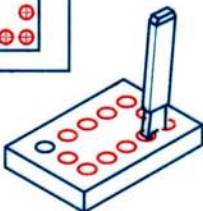
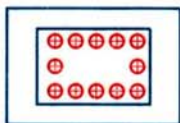
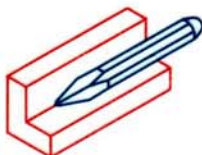
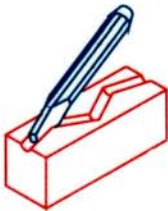
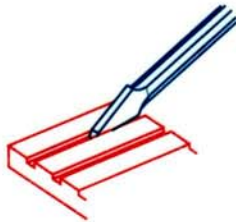
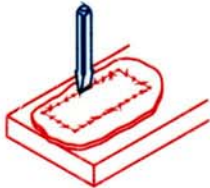
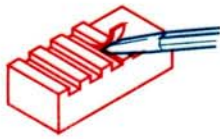

(a) Flat chisel

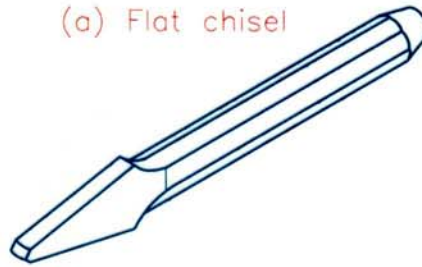

(b) Cross-Cut Chisel

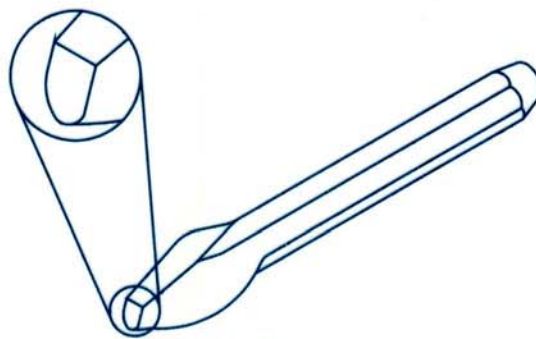

(c) Round-nose chisel

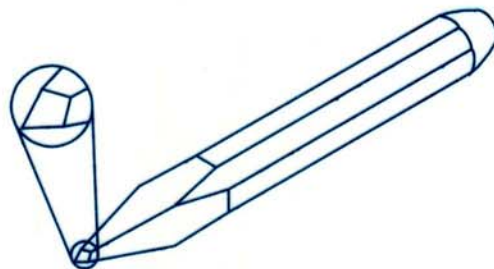

(D) Diamond-point chisel



(e) Web chisel

## TYPES OF CHISELS AND APPLICATION

TR01 01 01 0493

**CIMI** CENTRAL INSTRUCTIONAL MEDIA INSTITUTE, MADRAS  
AN INDO-GERMAN PROJECT

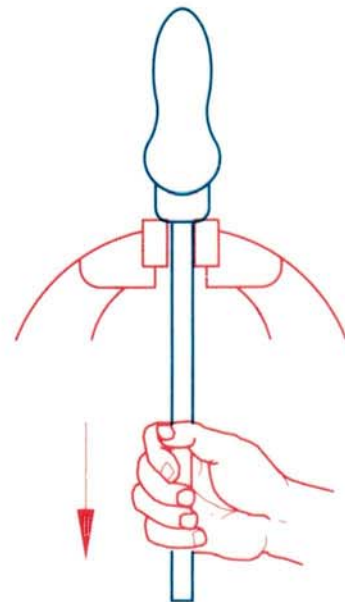
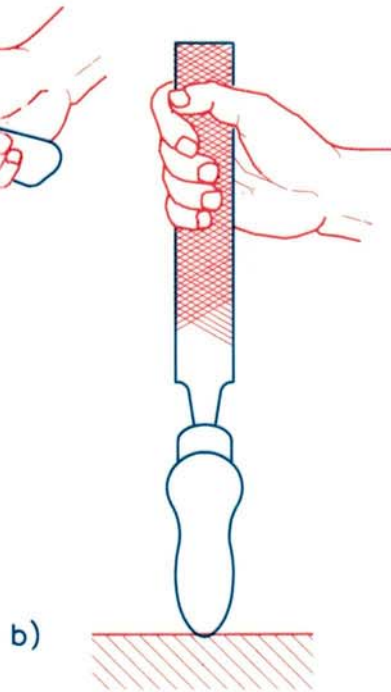
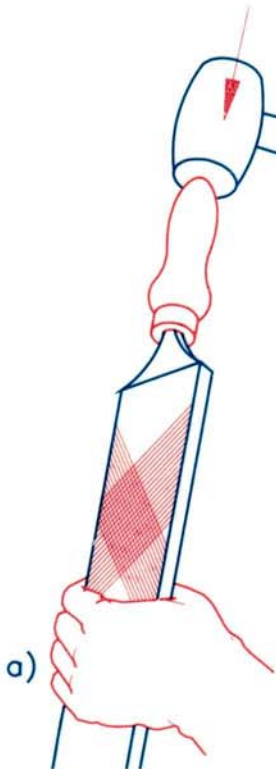
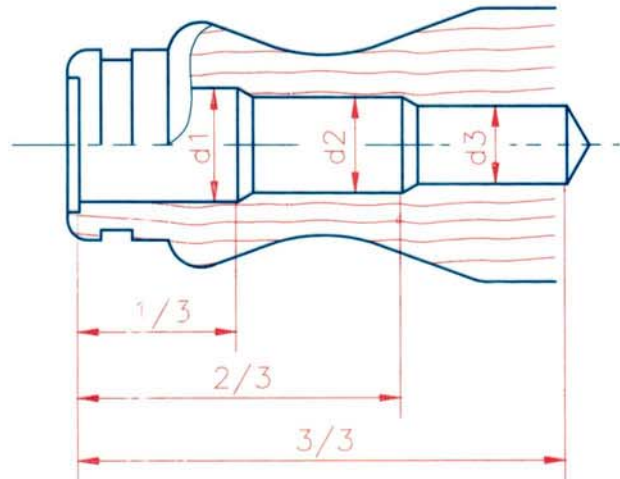
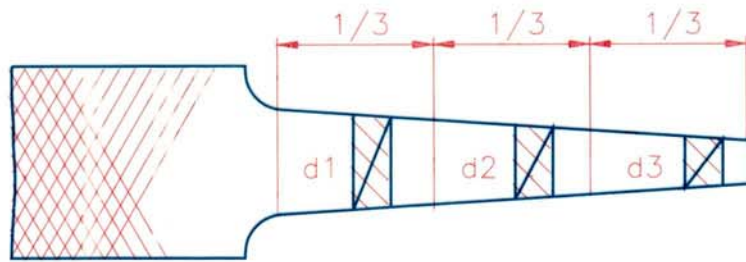

## FIXING FILE HANDLES

TR0101010593

**CIMI** CENTRAL INSTRUCTIONAL  
MEDIA INSTITUTE, MADRAS  
AN INDO-GERMAN PROJECT

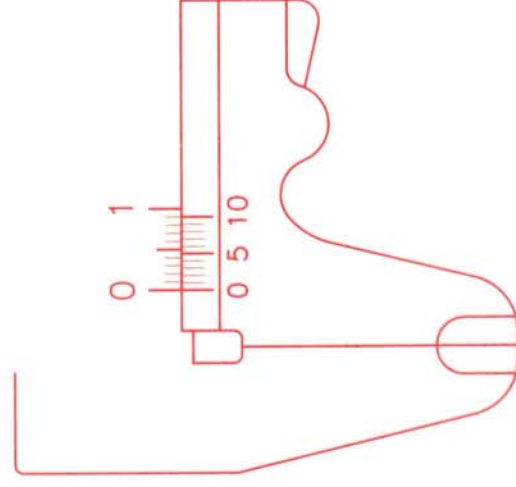
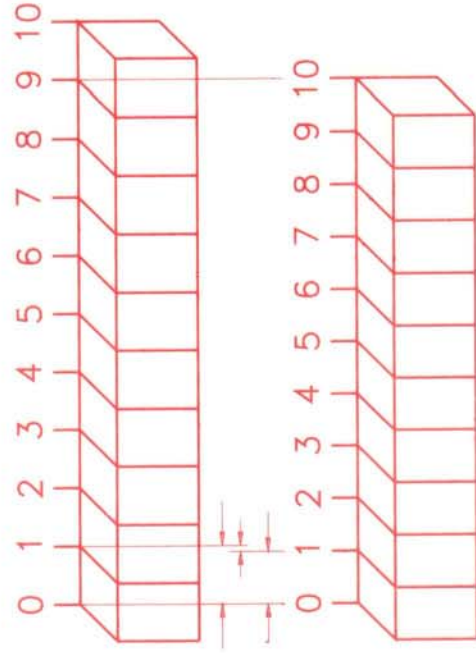
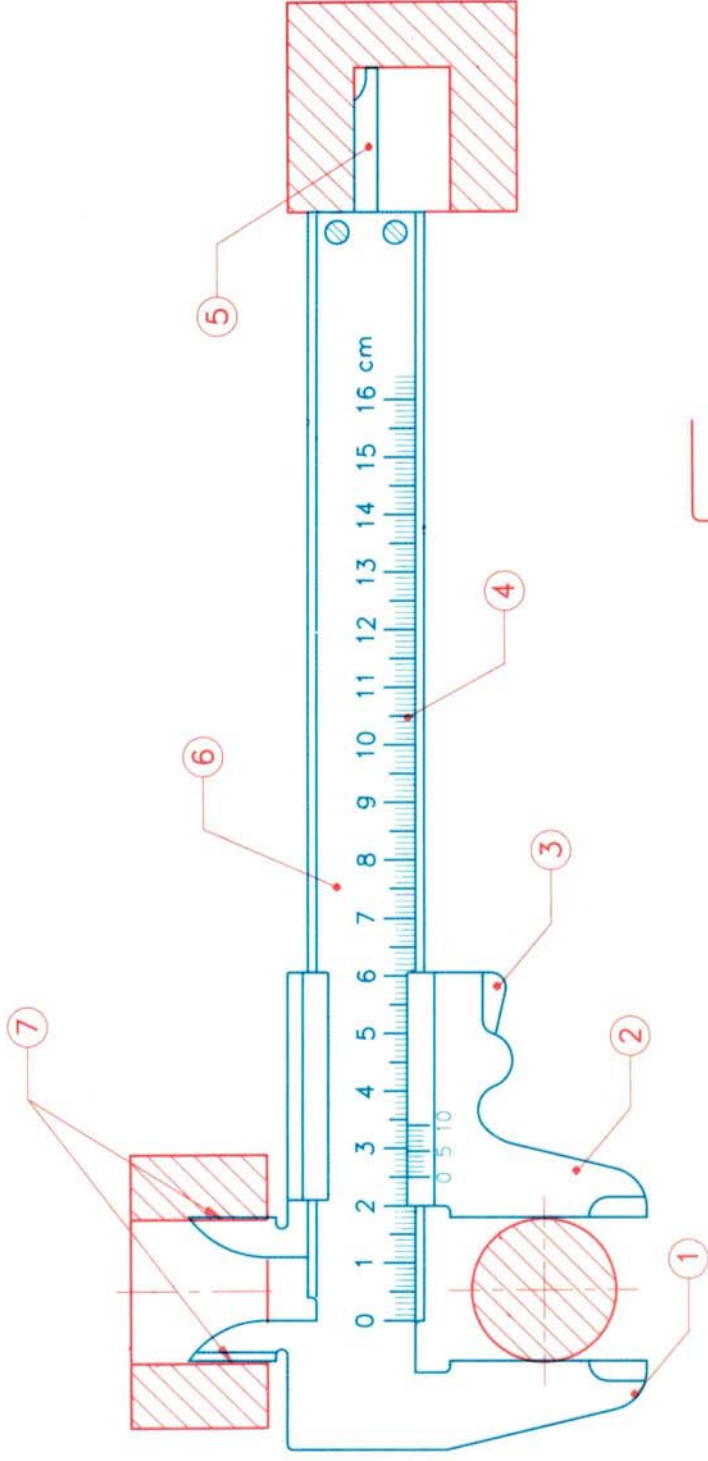

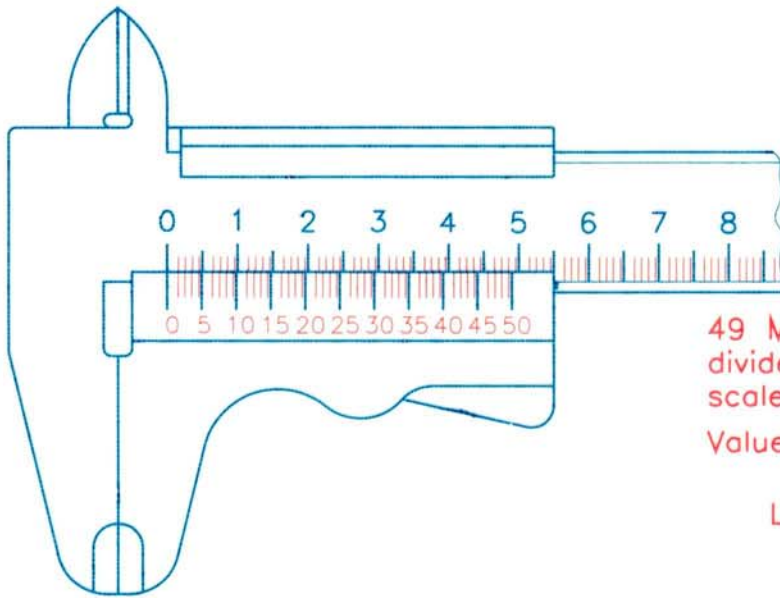

49 Main scale divisions are divided into 50 vernier scale divisions

$$\text{Value of 1 VSD} = \frac{49}{50} \text{ mm}$$

$$\text{Least count} = 1 \text{ MD} - 1 \text{ VSD}$$

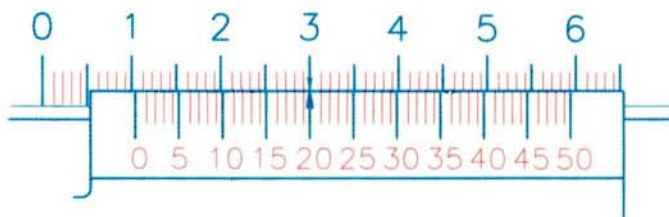

Main scale reading =

Value of coinciding vernier division } =

Reading =

Assignments:-

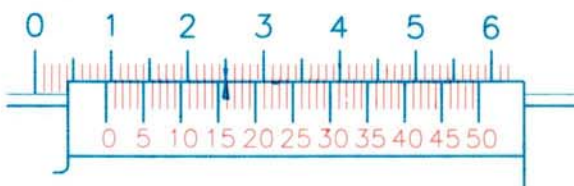

A Reading

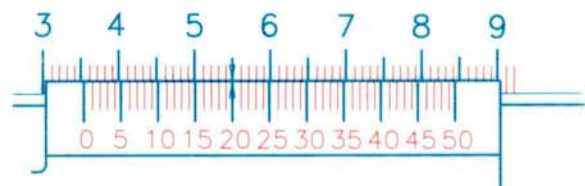

B Reading

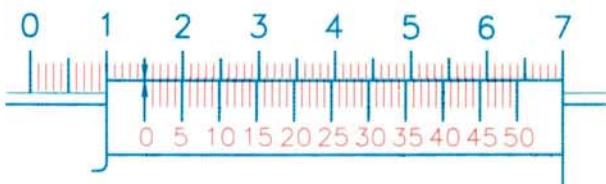

C Reading



D Reading

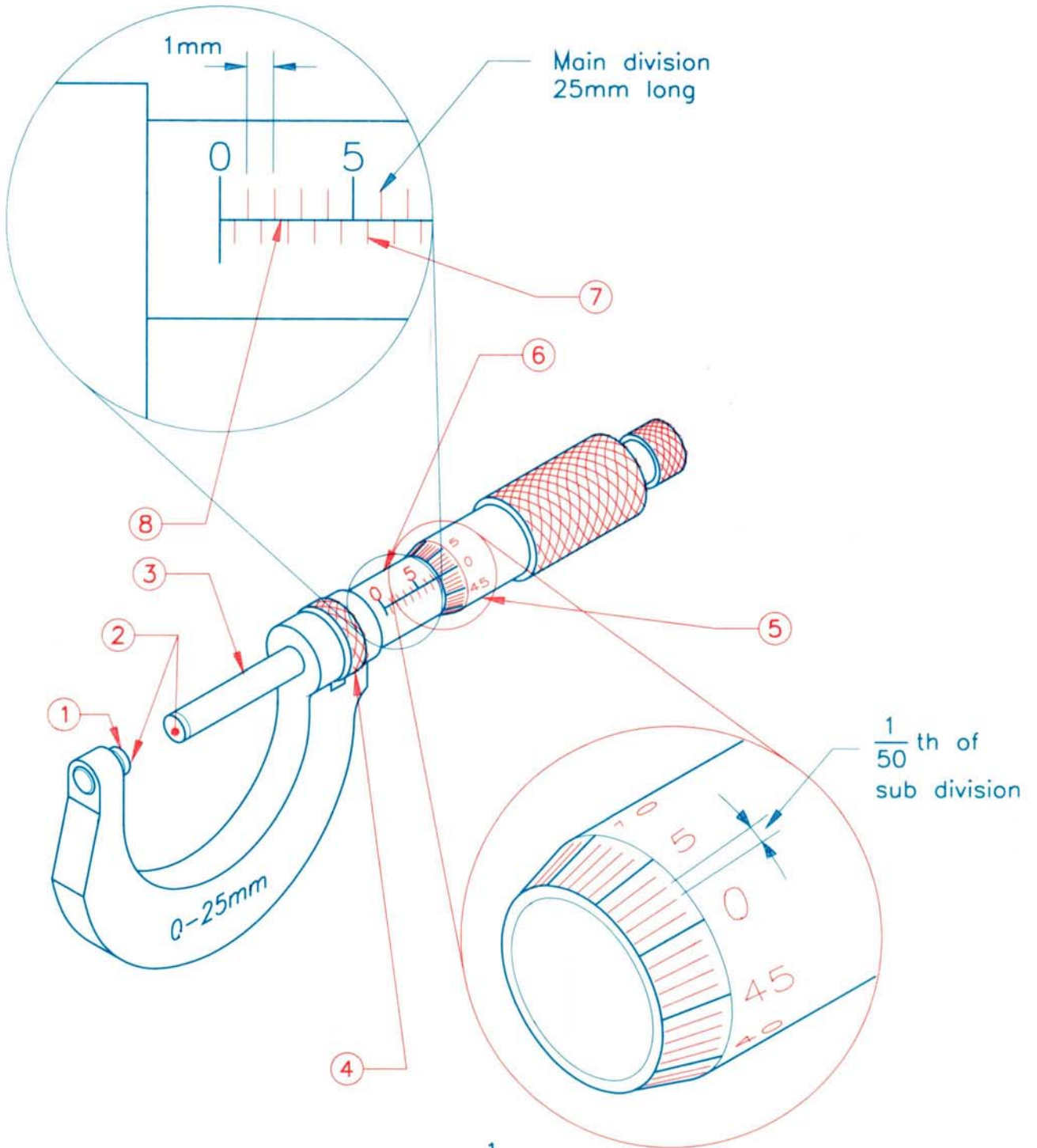

$$\text{Least count} = \frac{1}{50} \text{ th of } 0.5$$

$$= \boxed{\phantom{0.01}}$$

## MICROMETER PARTS AND GRADUATIONS

TR01 020201 93

**CIMI** CENTRAL INSTRUCTIONAL  
MEDIA INSTITUTE, MADRAS  
AN INDO-GERMAN PROJECT



## Micrometer graduations

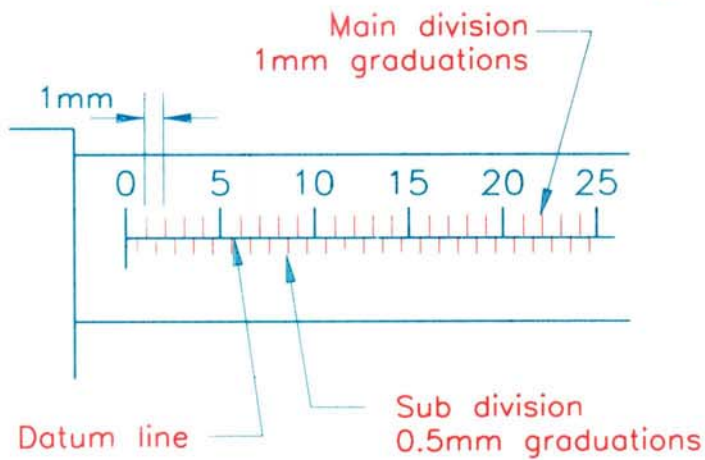

0.5mm - one rotation of thimble-  
graduated into 50 parts

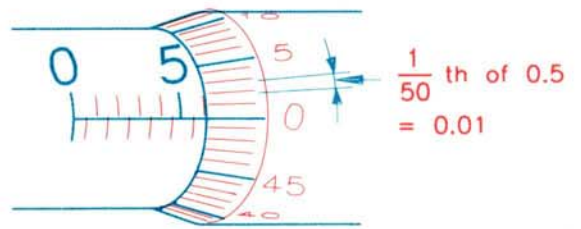

Thimble divisions  
0.01mm graduations

## Micrometer reading

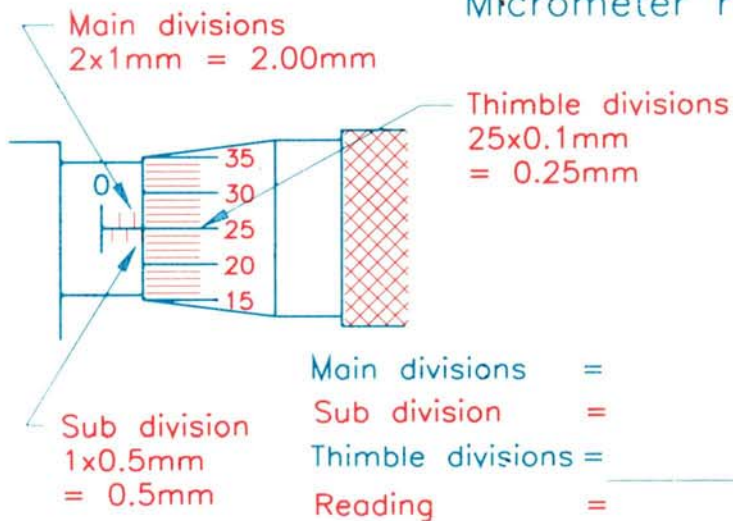

Example

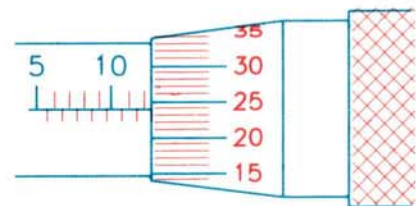

Assignments:-

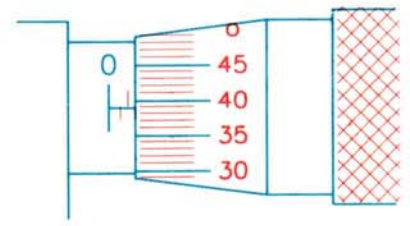
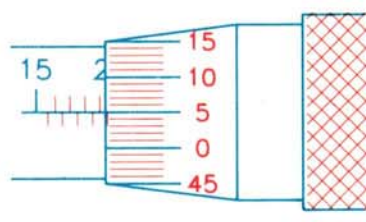
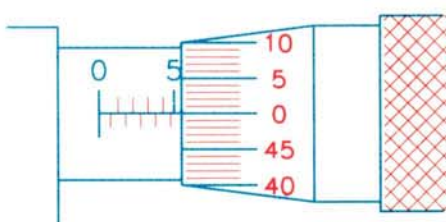

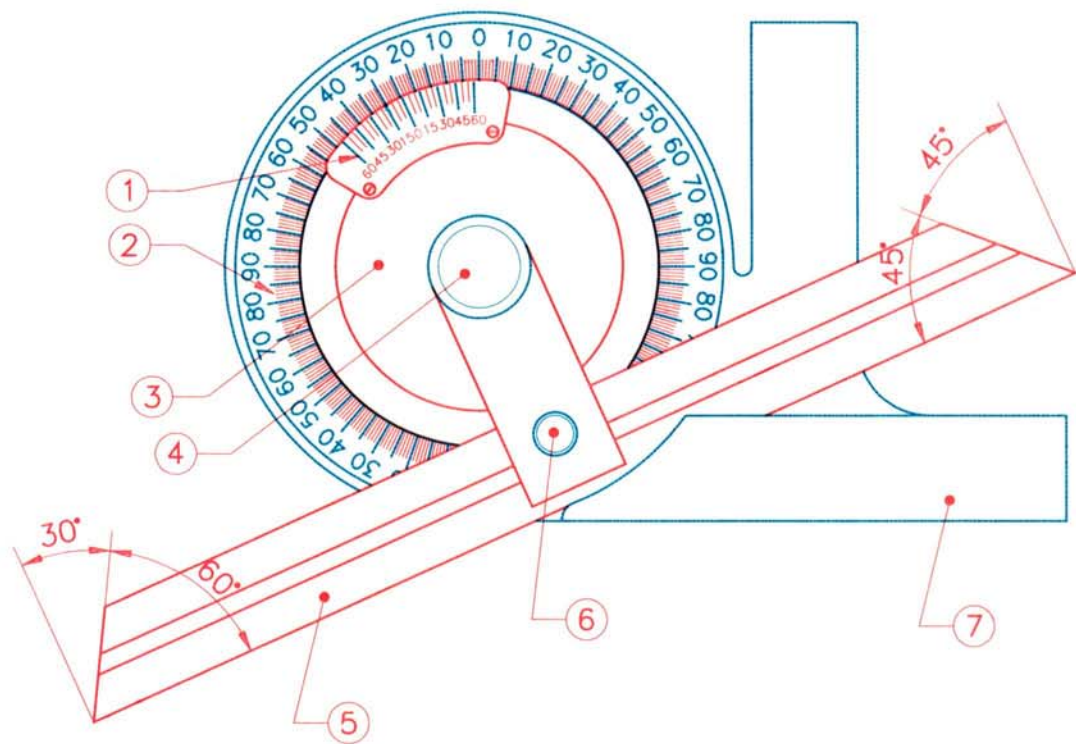

Applications:-

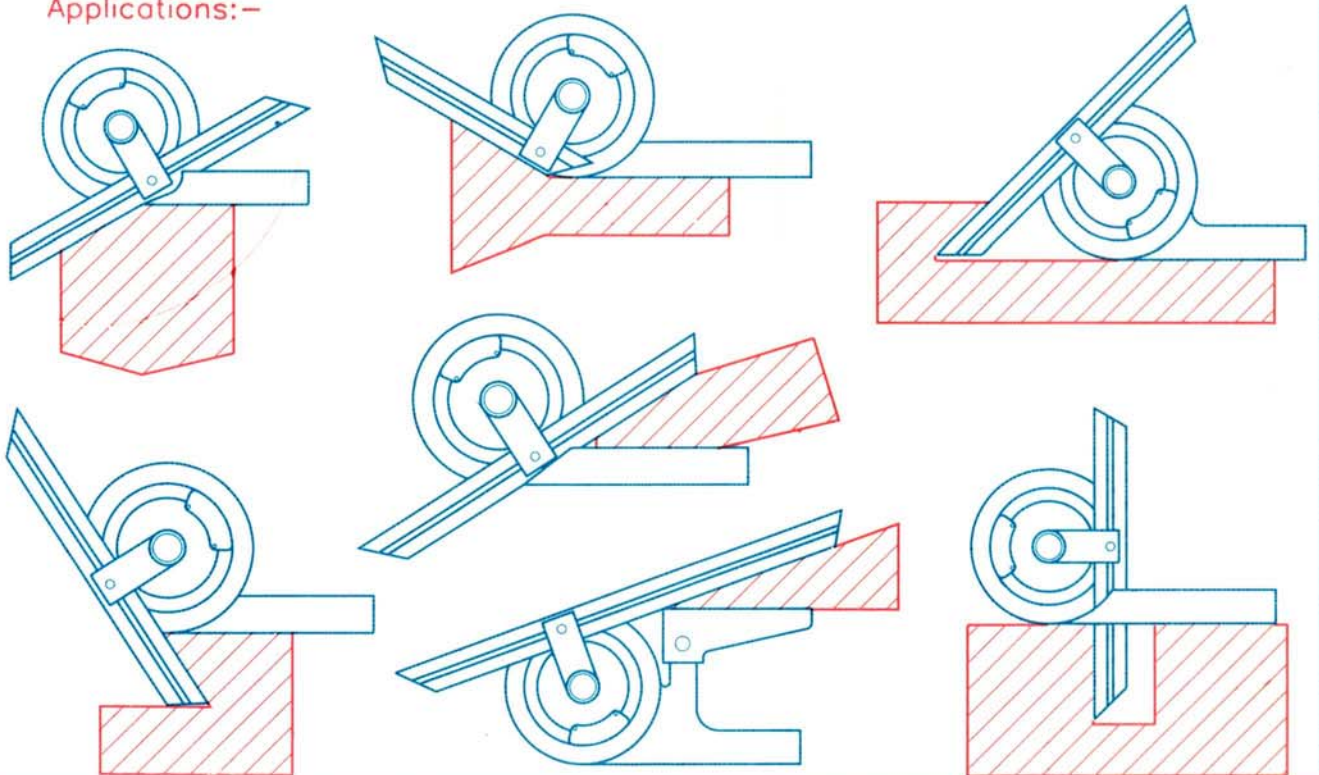

**VERNIER BEVEL PROTRACTOR  
PARTS & APPLICATION**

TR0102030193

**CIMI** CENTRAL INSTRUCTIONAL  
MEDIA INSTITUTE, MADRAS  
AN INDO-GERMAN PROJECT

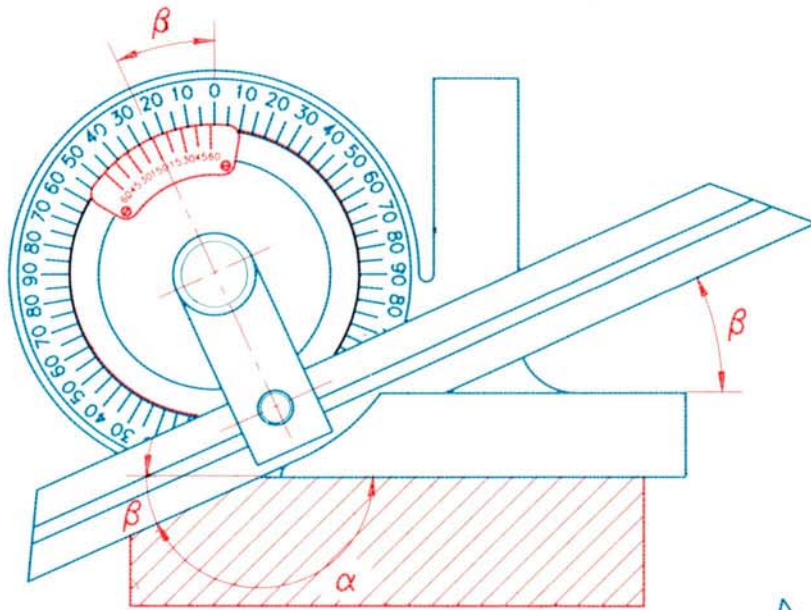

Obtuse angle  
 $\alpha = 180^\circ - \beta$

Assignments:-



A Reading



B Reading



C Reading

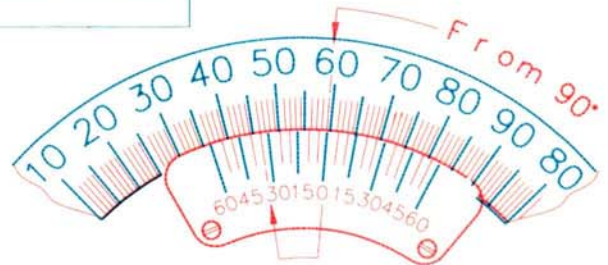

D Reading

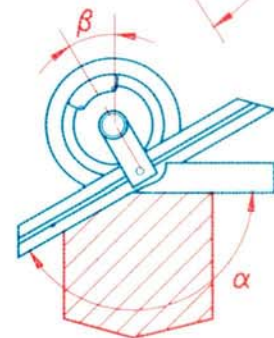
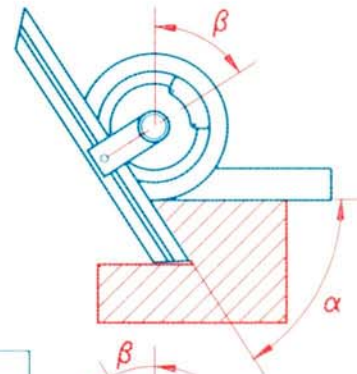

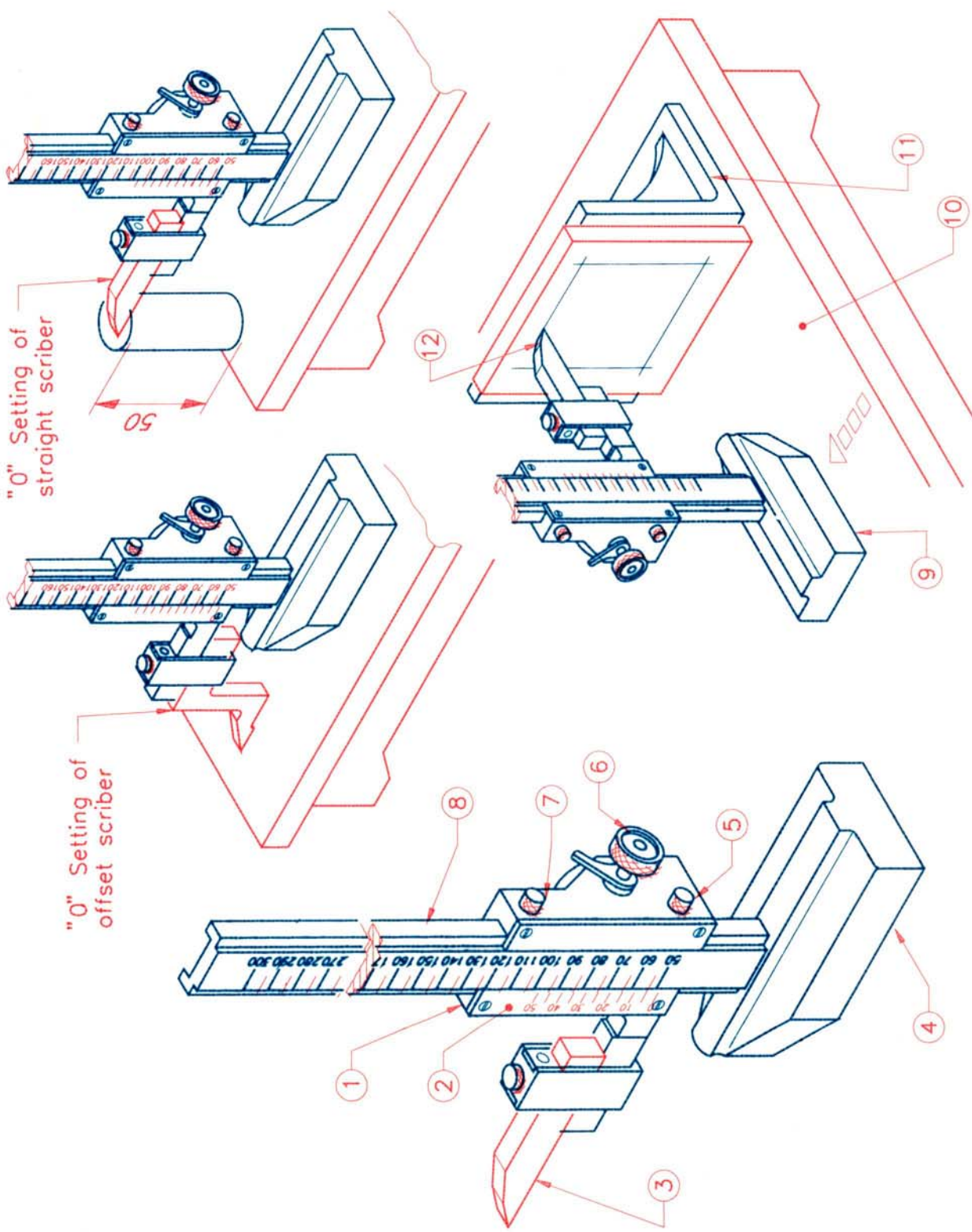

"0" Setting of straight scribe

"0" Setting of offset scribe

# VERNIER HEIGHT GAUGE

TR01 02 04 01.93

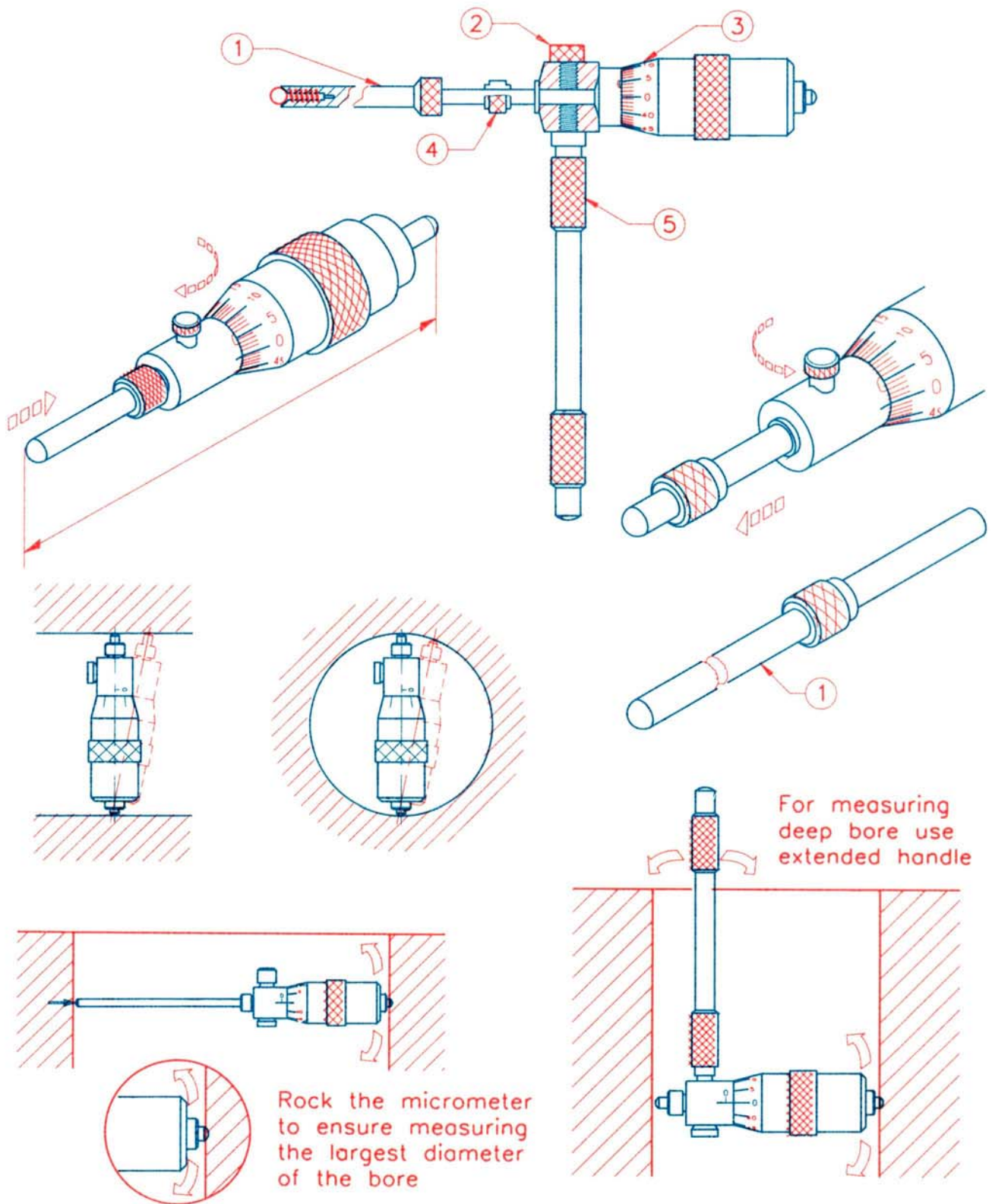

# INSIDE MICROMETER

TR0102050193

**CIM** CENTRAL INSTRUCTIONAL  
 MEDIA INSTITUTE, MADRAS  
 AN INDO-GERMAN PROJECT

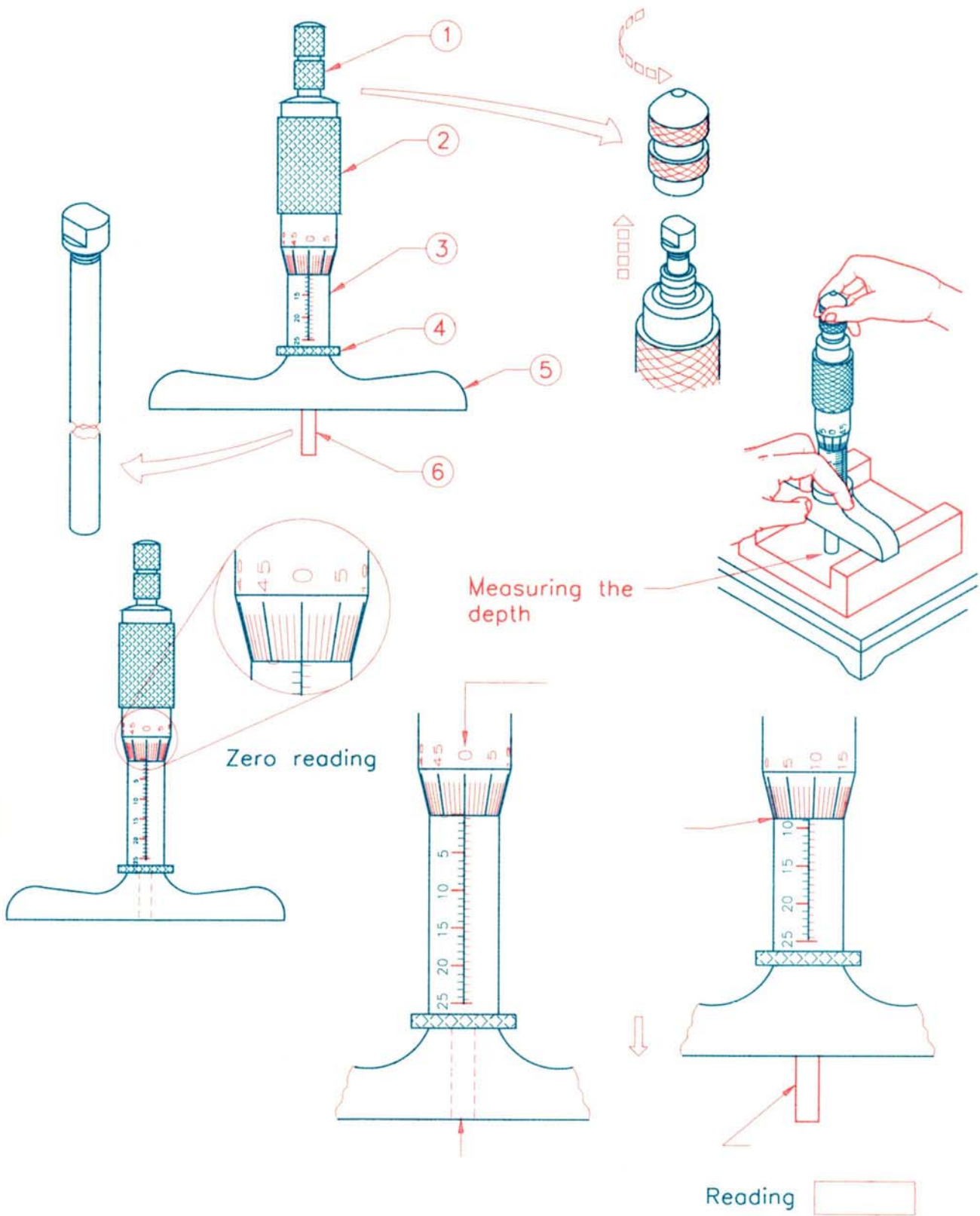

**DEPTH MICROMETER**

TR0102060193

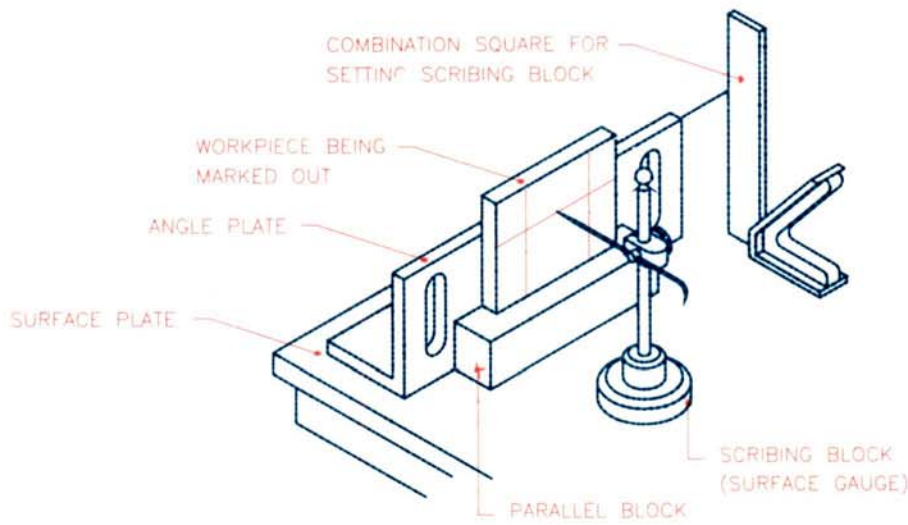
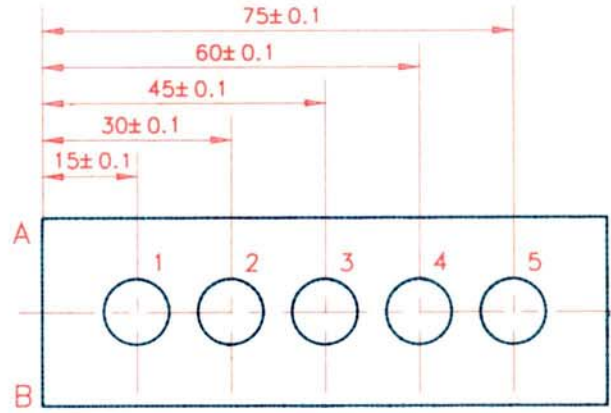
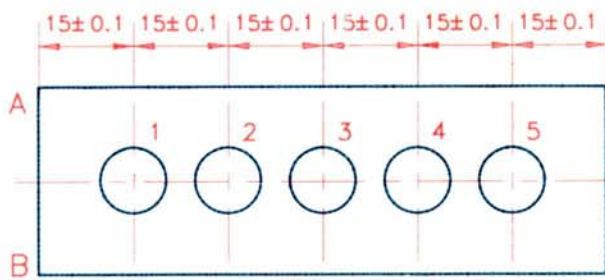

EDGE DATUM

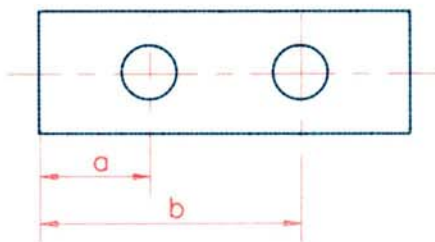

LINE DATUM

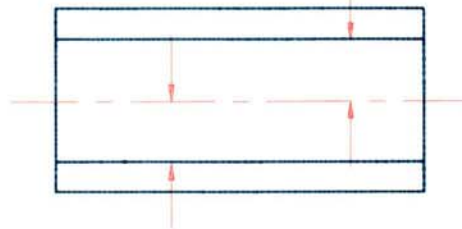

POINT DATUM

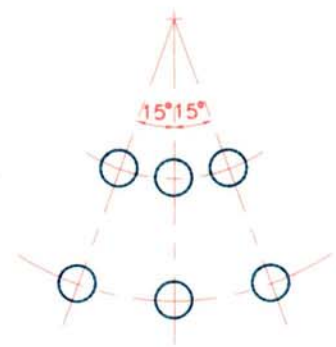

51-A-46-H-5-V-8

Type of abrasive

A - Aluminium oxide  
C - Silicon carbide

51-A-46-H-5-V-8

Grain size : (grit)  
The actual size of the abrasive grain

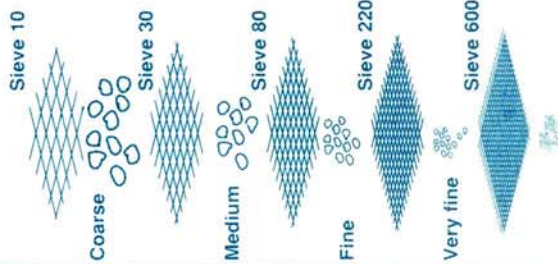

51-A-46-H-5-V-8

Grade :  
The strength of the bond holds the grain in position

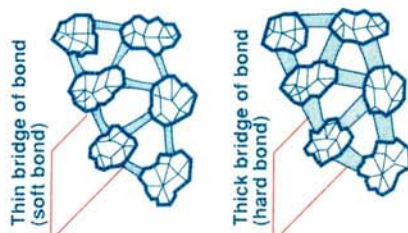

51-A-46-H-5-V-8

Structure :  
The amount of bond present between the abrasive grains.

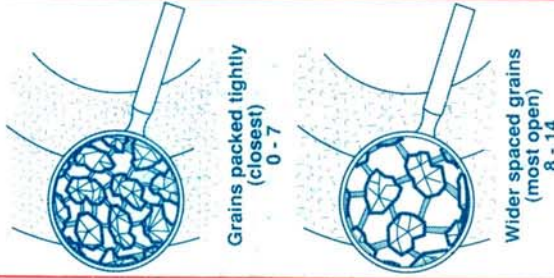

51-A-46-H-5-V-8

Type of bond

V - Vitrified  
S - Silicate  
R - Rubber  
RF - Rubber reinforced  
B - Resinoid (Synthetic resins)  
BF - Resinoid reinforced  
E - Shellac  
Mg - Magnesia

51-A-46-H-5-V-8

Manufacturer's symbol for abrasive (Optional)

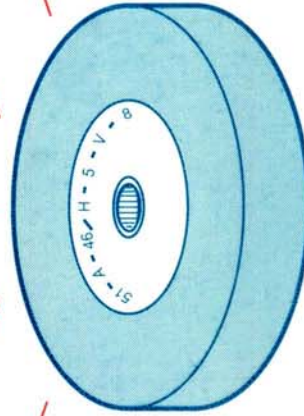

51-A-46-H-5-V-8

Manufacturer's own identification mark for the wheel (Optional)

# GRINDING WHEEL MARKING

TR0104010193



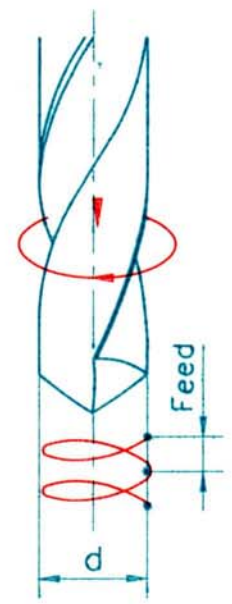
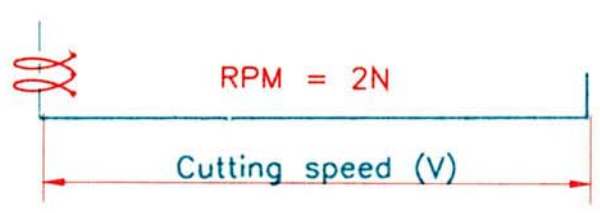
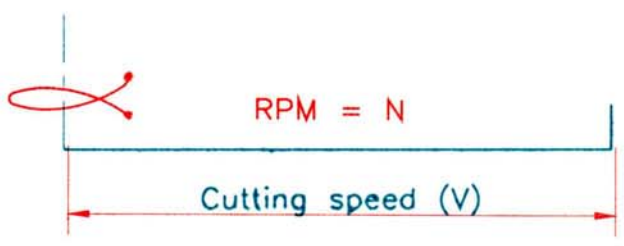
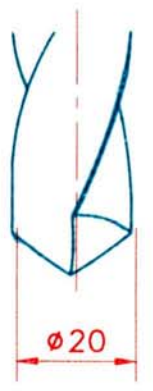
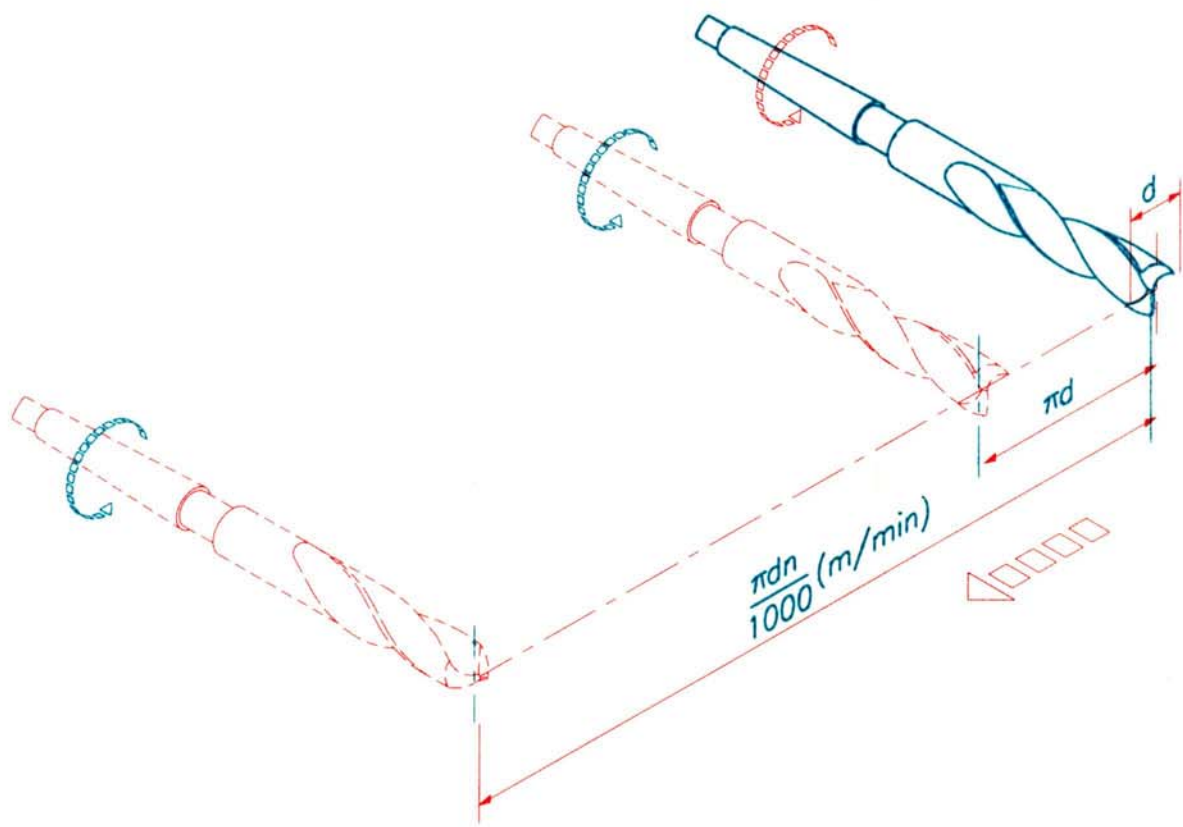

**CUTTING SPEED, FEED AND R.P.M. OF DRILLS**

TR0105010193

**CIMI** CENTRAL INSTRUCTIONAL MEDIA INSTITUTE, MADRAS  
AN INDO-GERMAN PROJECT

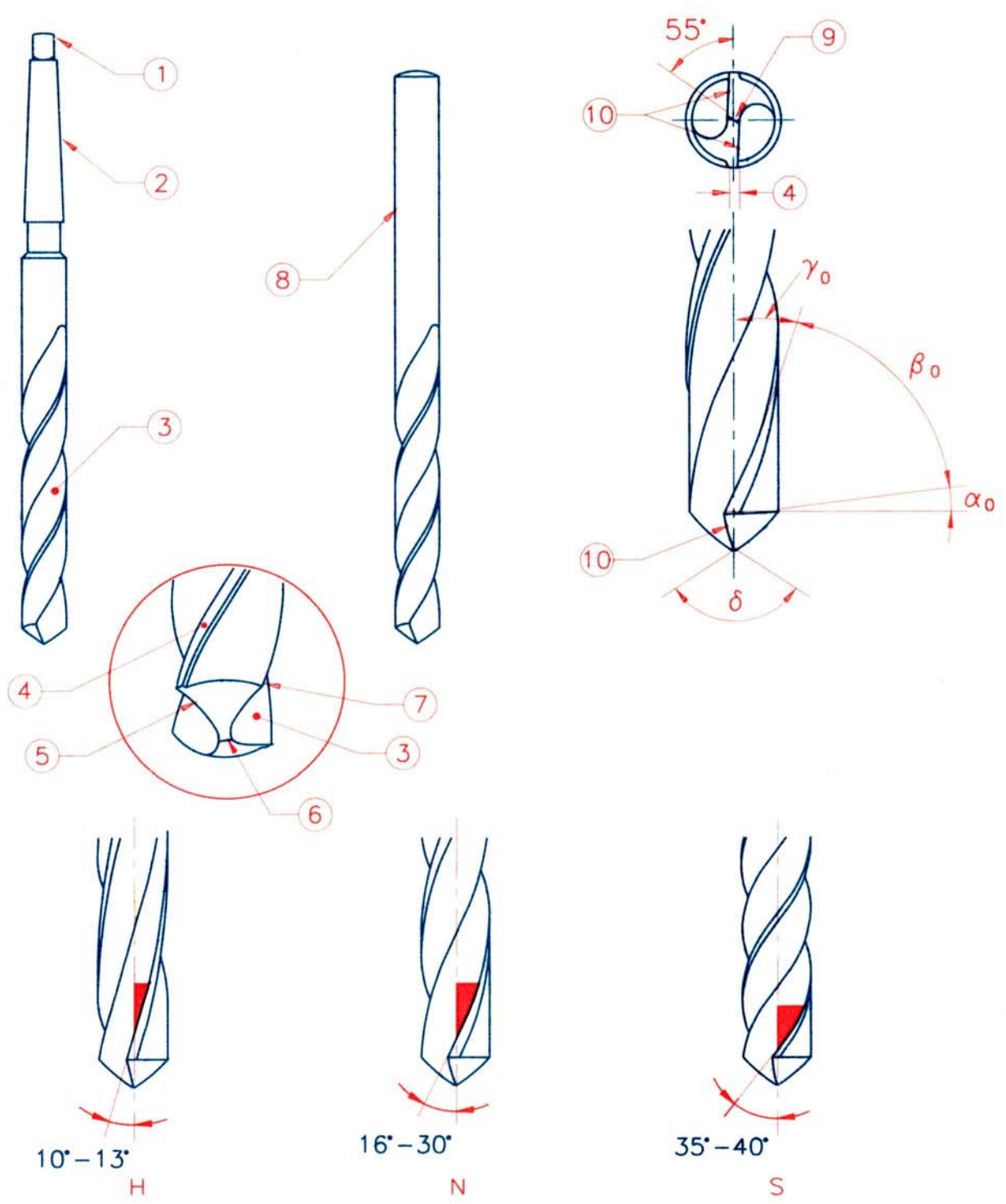

**DRILL PARTS AND ANGLES**

TR01 05 02 01 93

**CIMI** CENTRAL INSTRUCTIONAL MEDIA INSTITUTE, MADRAS  
AN INDO-GERMAN PROJECT

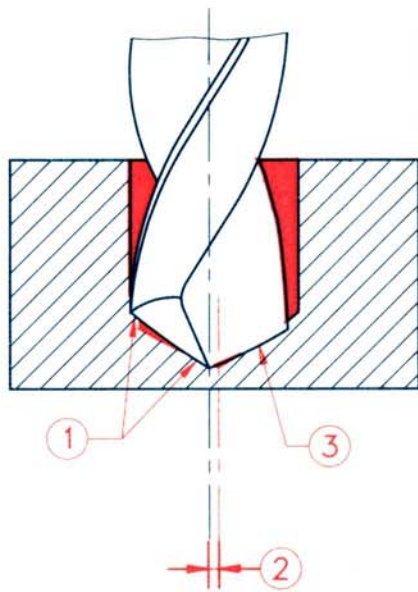

Cutting edges of unequal angles

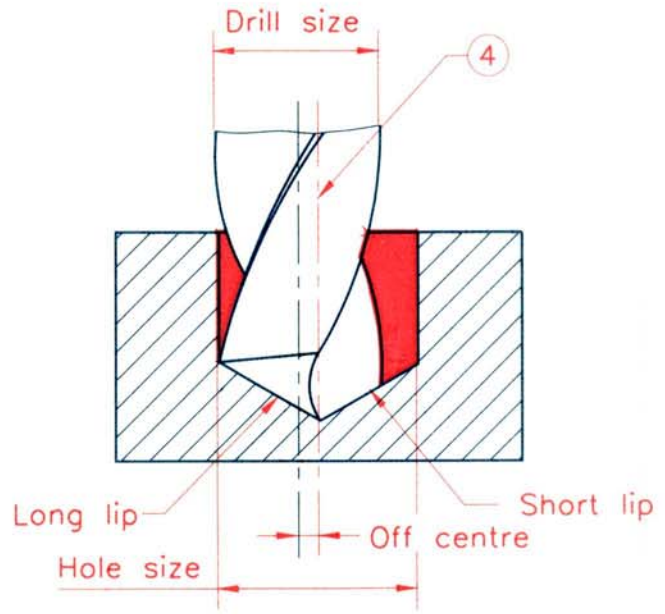

Cutting edges of unequal length but angles equal

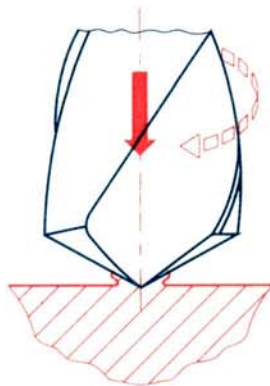

Thick web due to frequent grinding

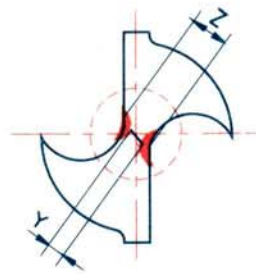

Web thinned by grinding

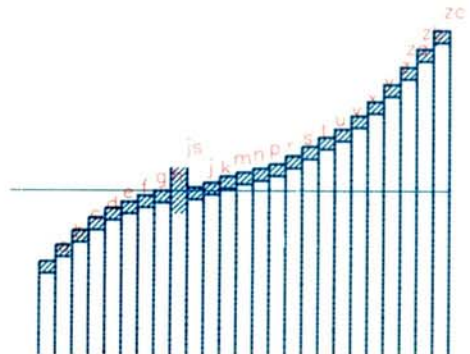
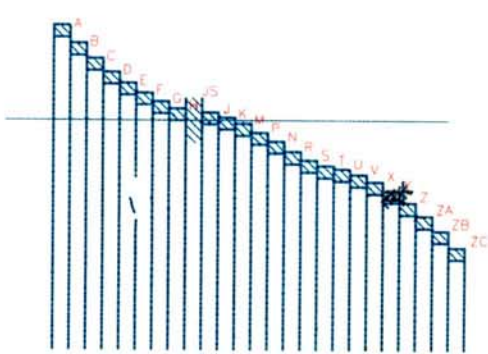
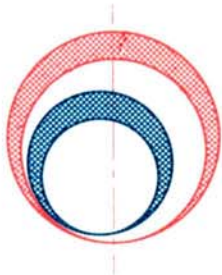
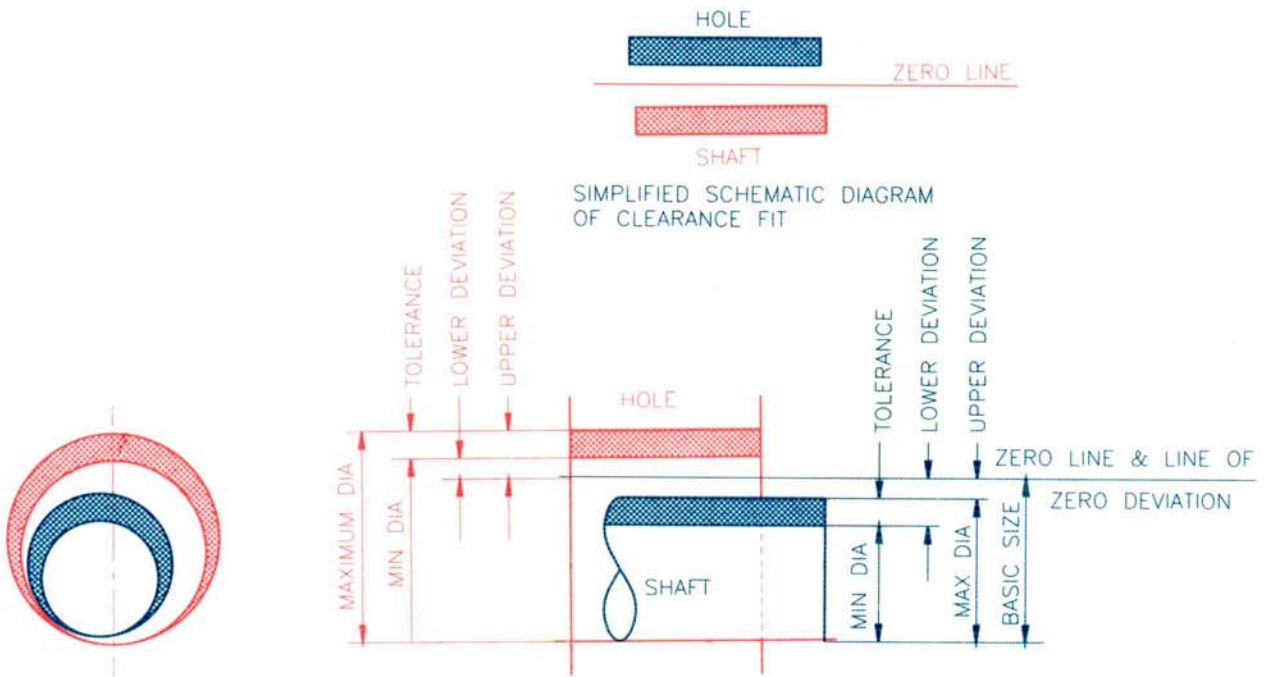

18 GRADES OF TOLERANCES

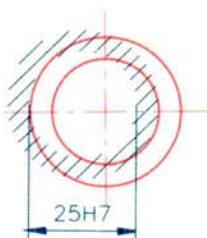

WHAT DOES 25H7 INDICATE?

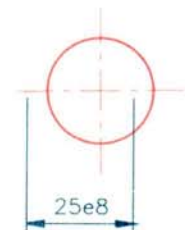
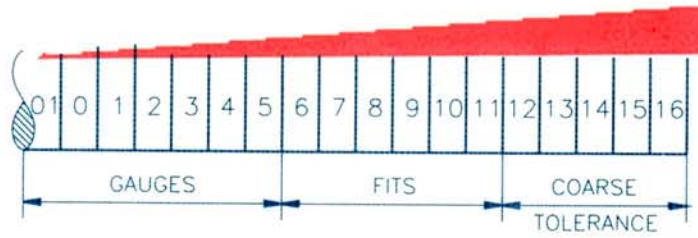

WHAT DOES 25e8 INDICATE?

**FUNDAMENTALS OF LIMITS AND FITS**

TR0106010193

**CIMI** CENTRAL INSTRUCTIONAL MEDIA INSTITUTE, MADRAS  
AN INDO-GERMAN PROJECT

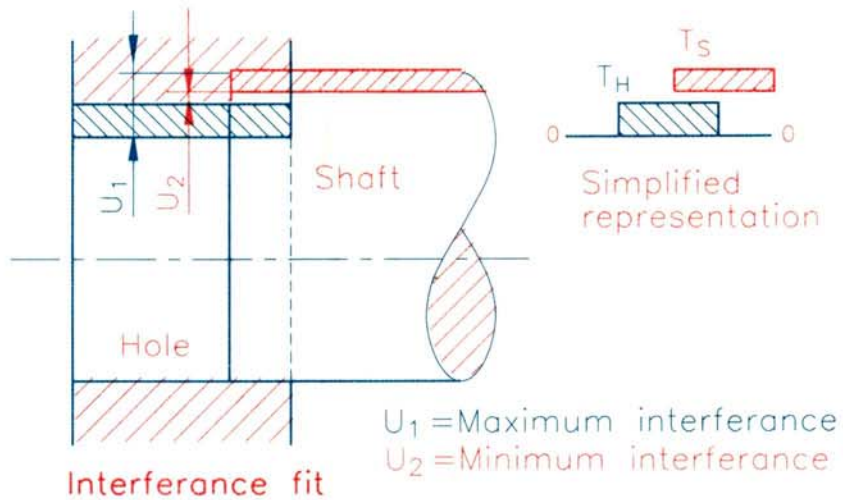
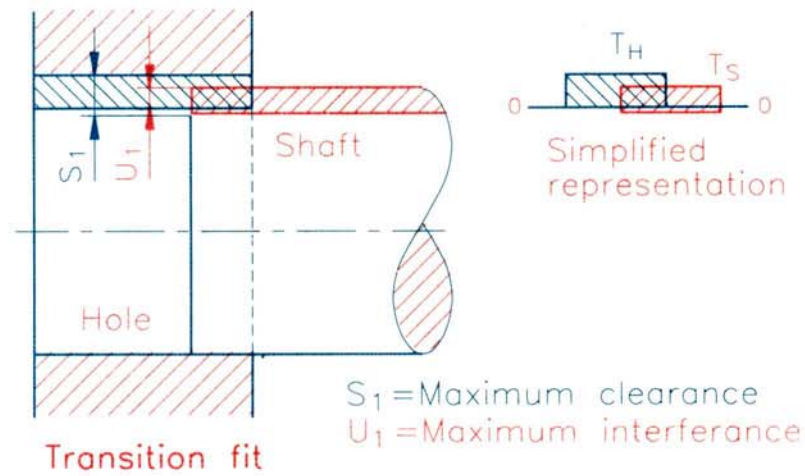
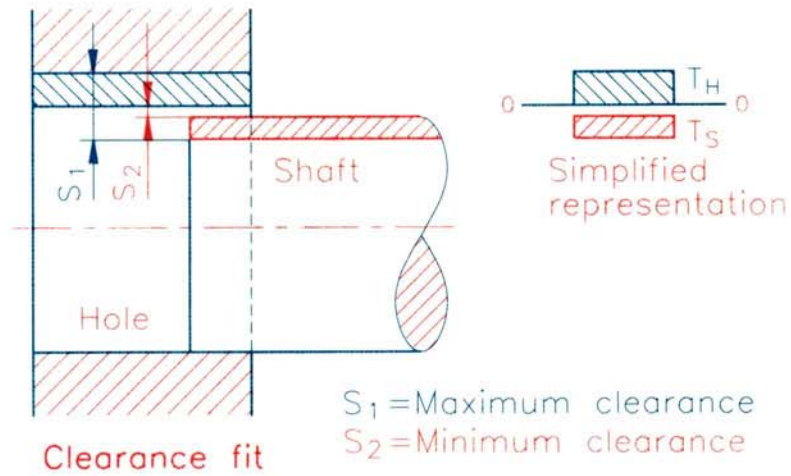

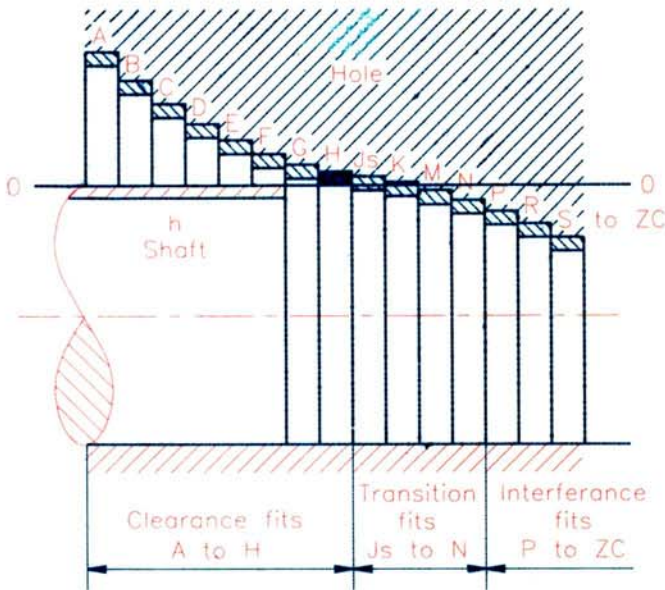

BASIC SHAFT SYSTEM

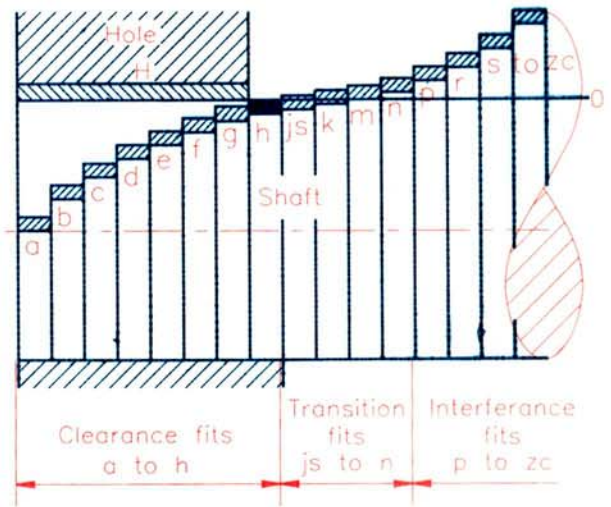

BASIC HOLE SYSTEM

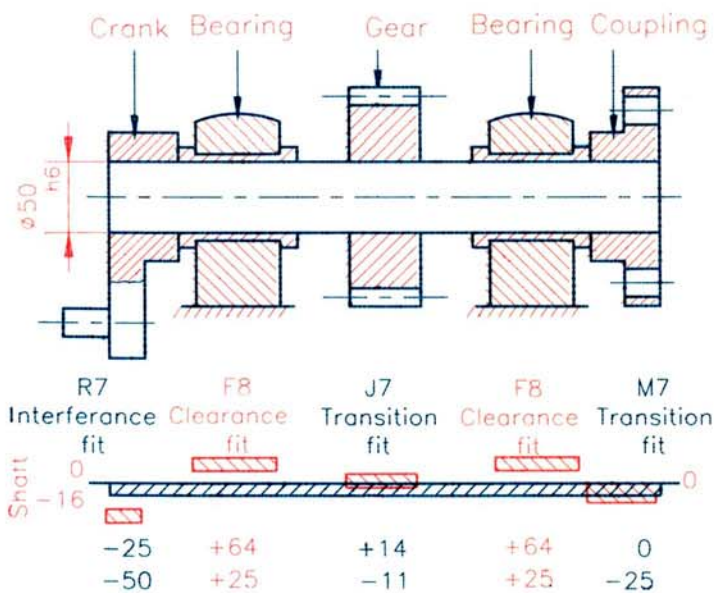

APPLICATION FOR THE BASIC SHAFT SYSTEM

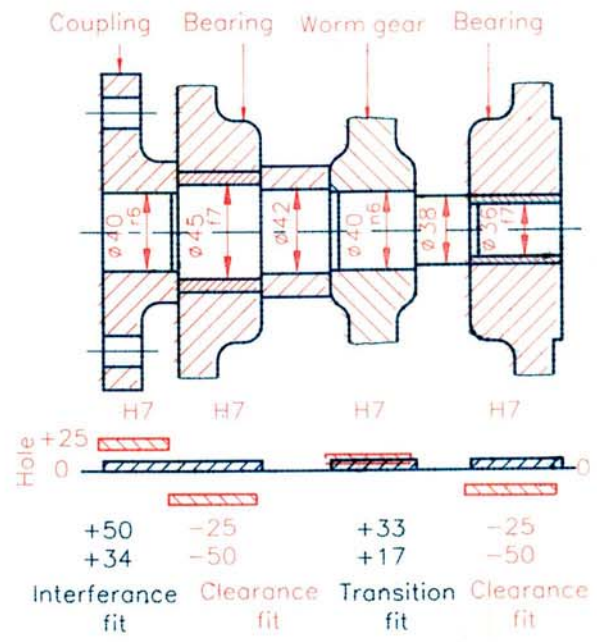

APPLICATION FOR THE BASIC HOLE SYSTEM

**SHAFT BASIS AND HOLE BASIS SYSTEM OF LIMITS AND FITS**

TR0106010393

**CIMI** CENTRAL INSTRUCTIONAL MEDIA INSTITUTE, MADRAS  
AN INDO-GERMAN PROJECT

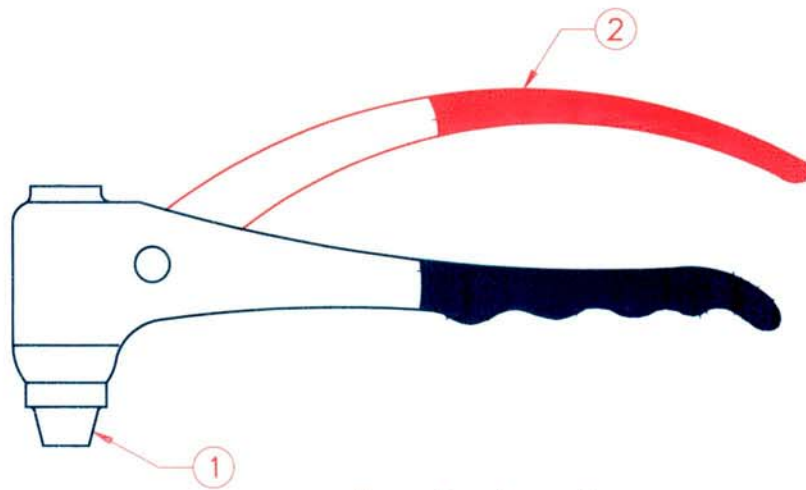

Pop riveting plier

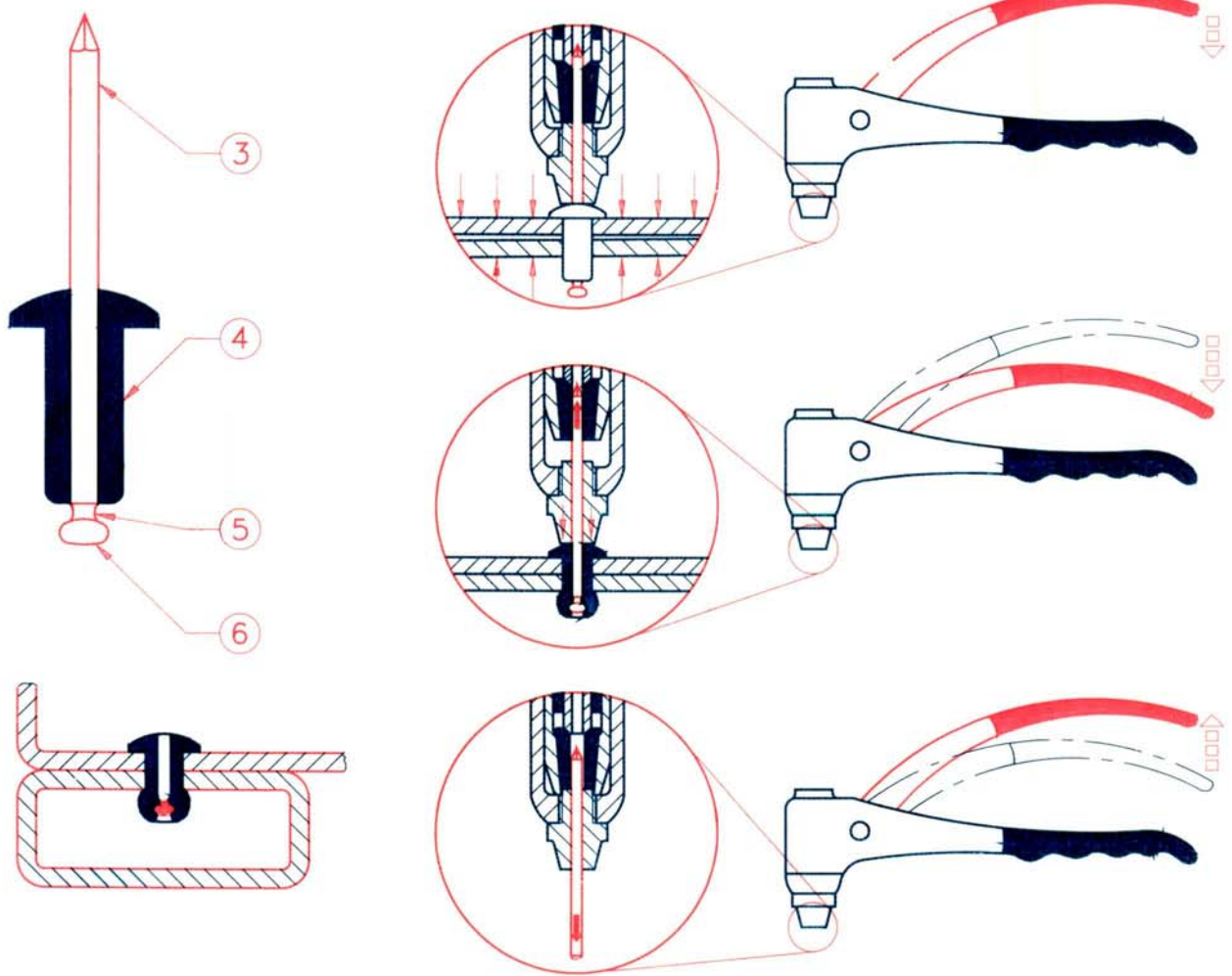

**BLIND RIVETING  
WITH POP RIVETS**

TR0111030193

**CIM** CENTRAL INSTRUCTIONAL  
MEDIA INSTITUTE, MADRAS  
AN INDO-GERMAN PROJECT

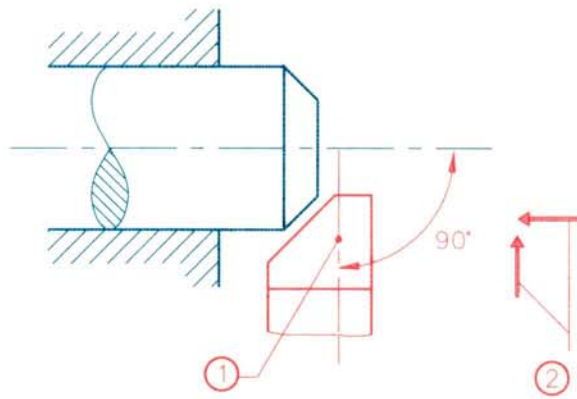

FORM TOOL METHOD

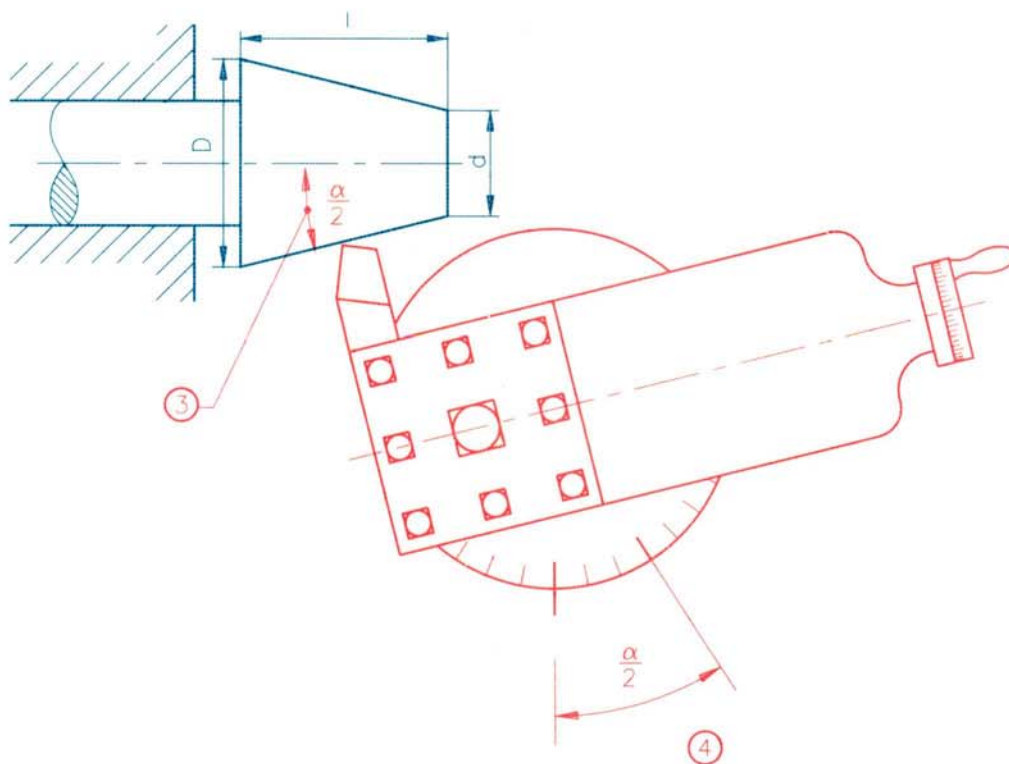

COMPOUND SLIDE METHOD

**DIFFERENT METHODS OF  
TAPER TURNING**  
(FORM TOOL AND COMPOUND REST)

TR01 15030193

**CIMI** CENTRAL INSTRUCTIONAL  
MEDIA INSTITUTE, MADRAS  
AN INDO-GERMAN PROJECT



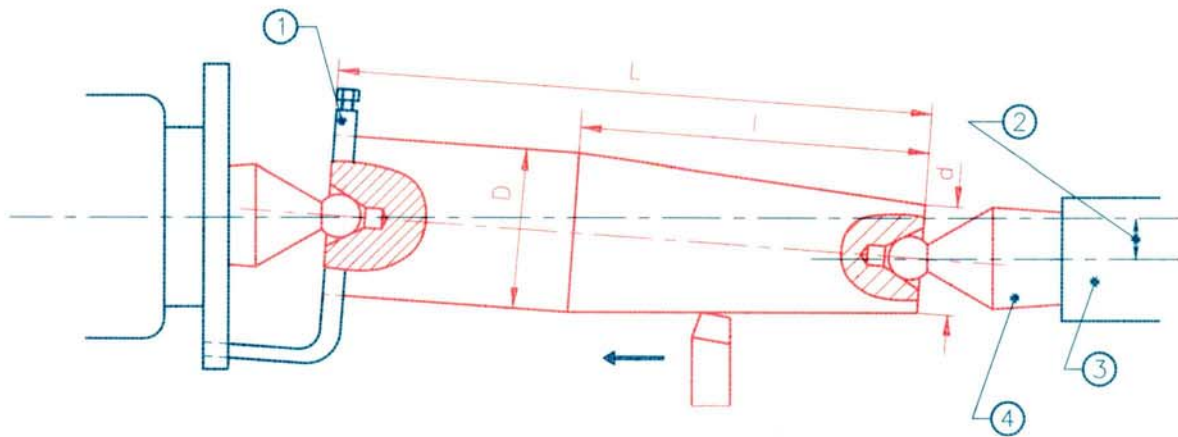

TAILSTOCK OFFSET METHOD

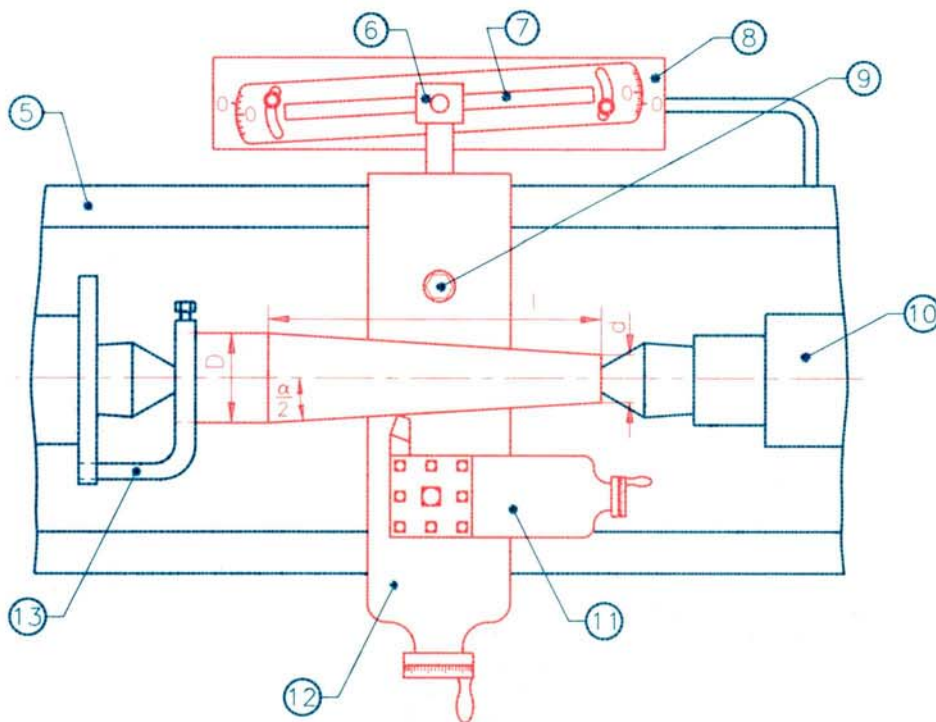

TAPER TURNING ATTACHMENT METHOD

## DIFFERENT METHODS OF TAPER TURNING

(TAILSTOCK SET OVER AND TAPER TURNING ATTACHMENT)

TR01 15030293

**CIMI** CENTRAL INSTRUCTIONAL  
MEDIA INSTITUTE, MADRAS  
AN INDO-GERMAN PROJECT