

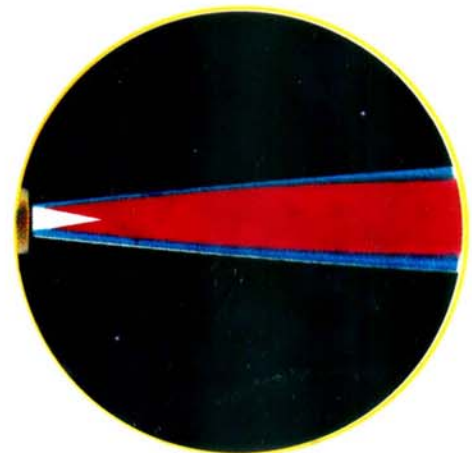

TYPES OF OXY-ACETYLENE FLAME

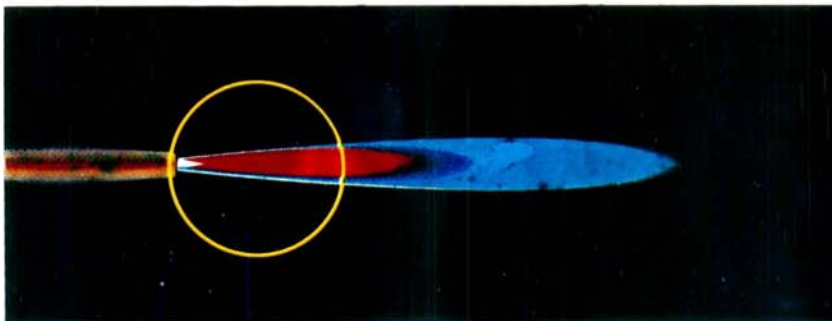

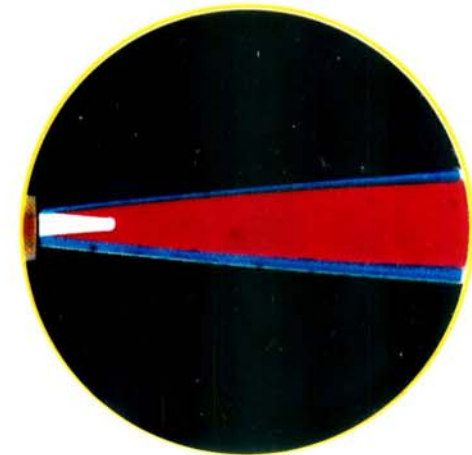
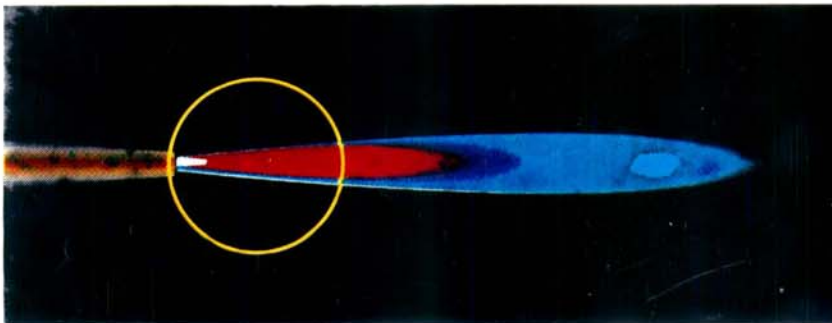
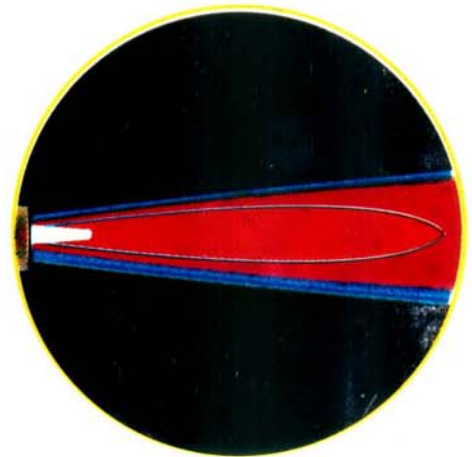
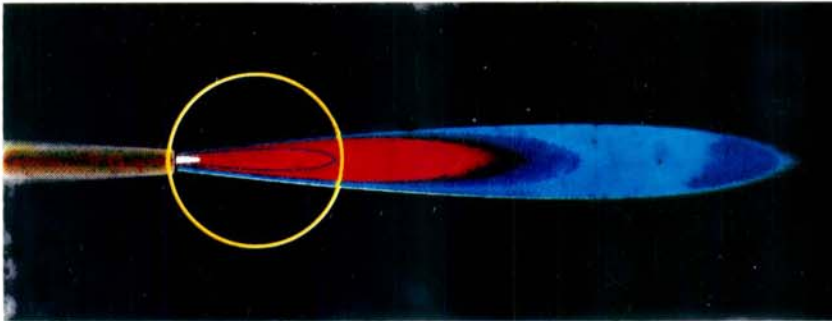

CHEMISTRY OF OXYGEN - ACETYLENE FLAME

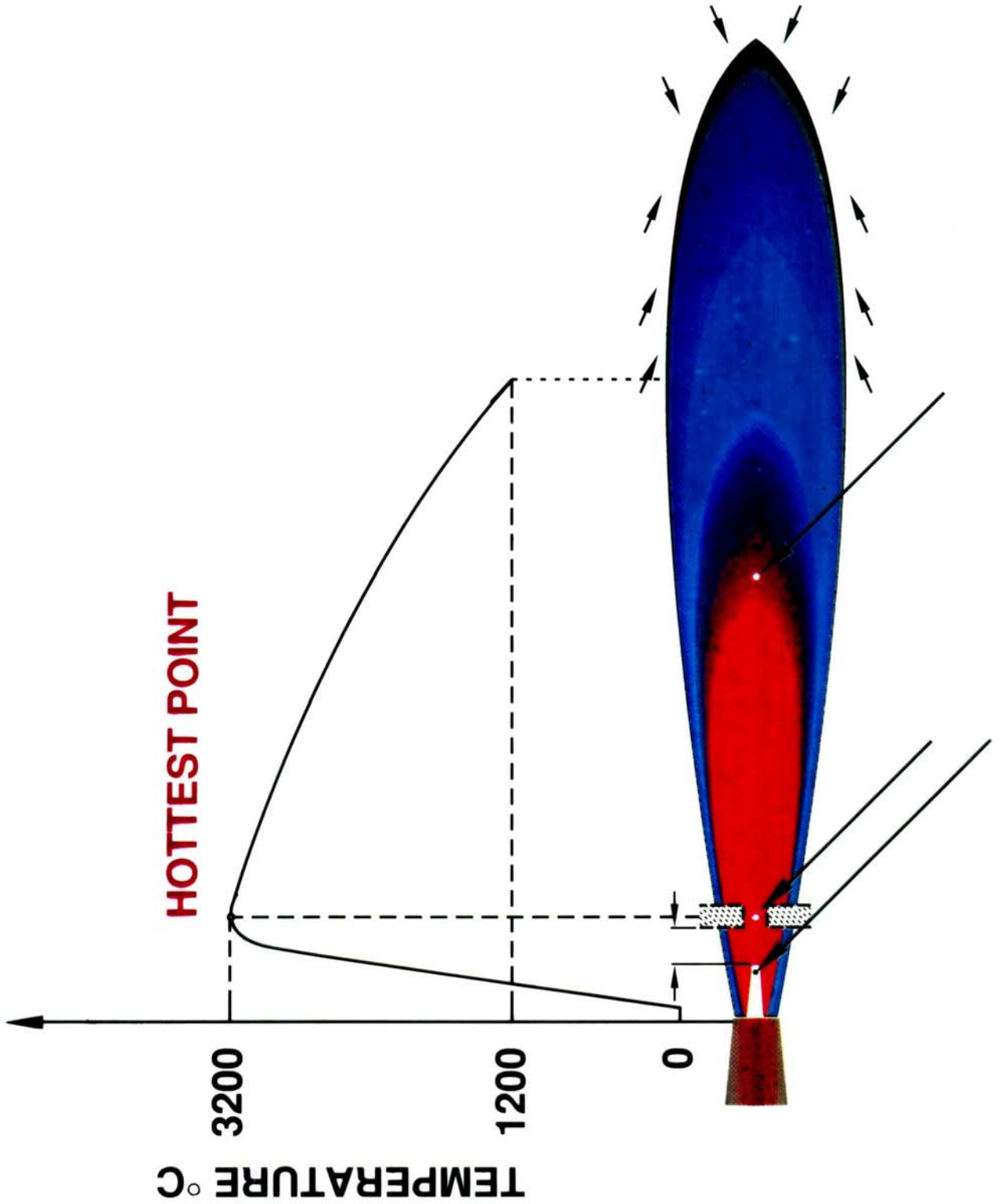



INFLUENCE OF DISCHARGE VELOCITY AND AMOUNT OF HEAT

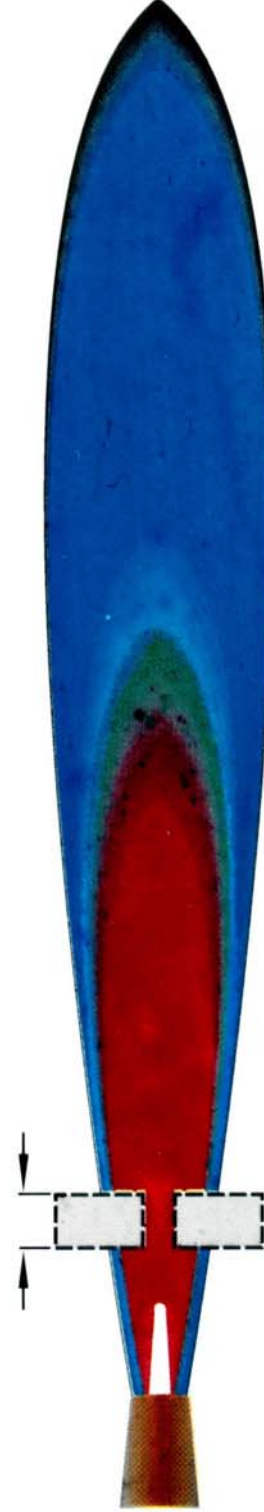
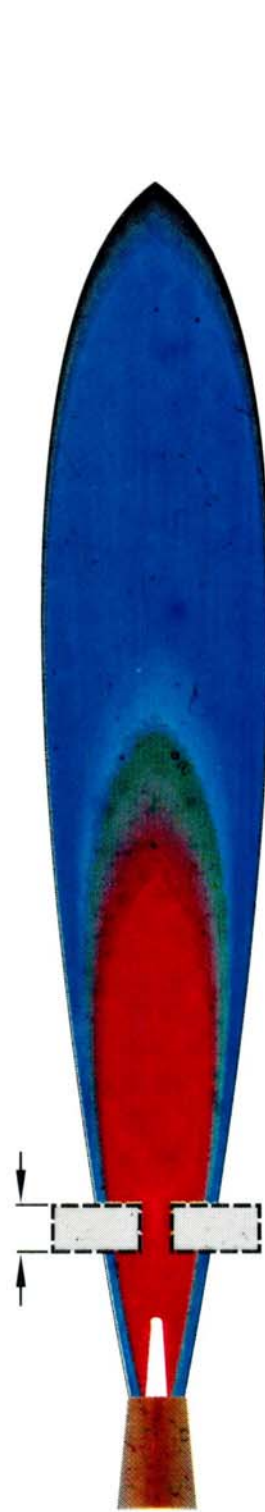



DOUBLE STAGE REGULATOR (FUNCTION)

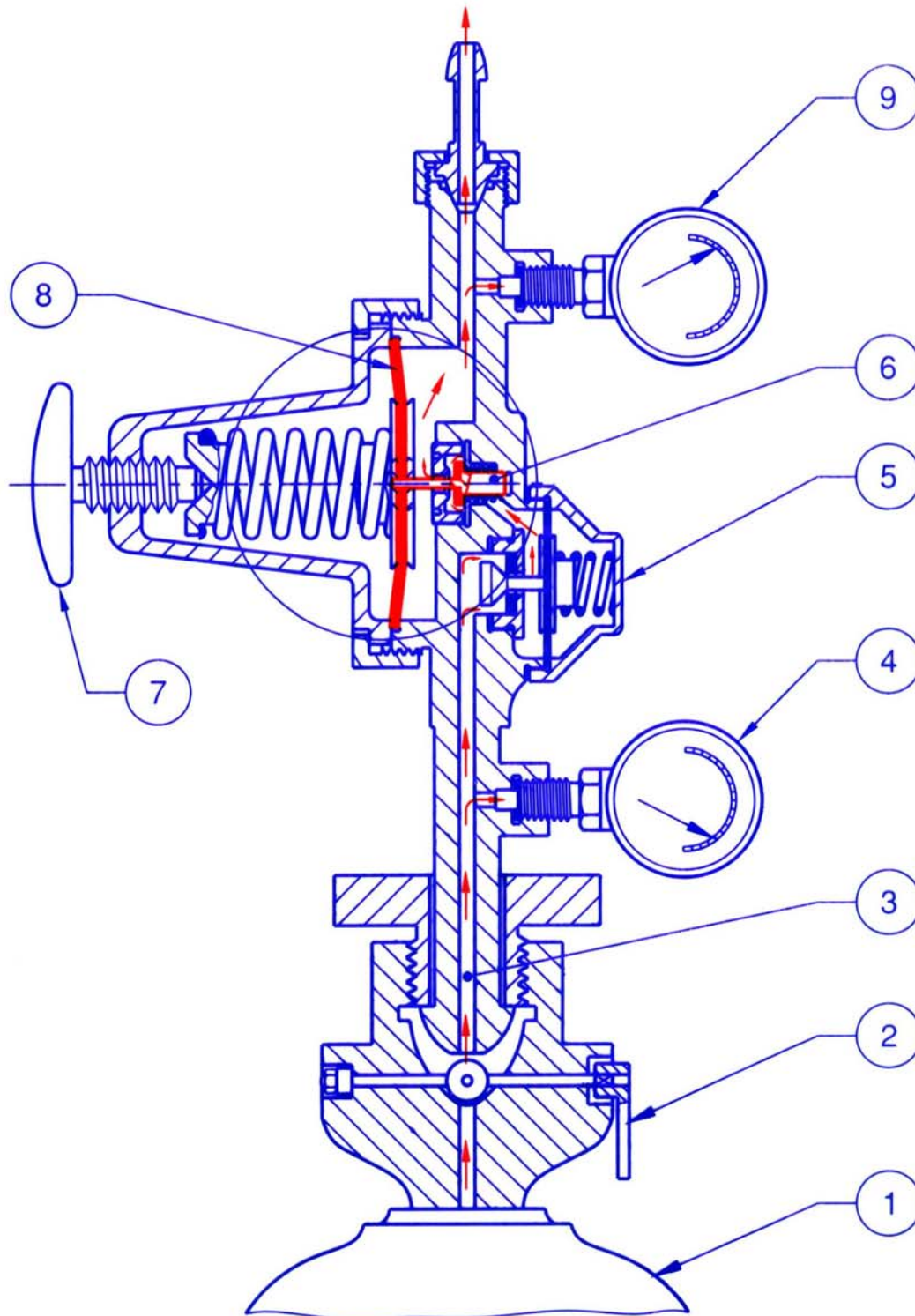



REGULATOR DIAPHRAGM (FUNCTION)

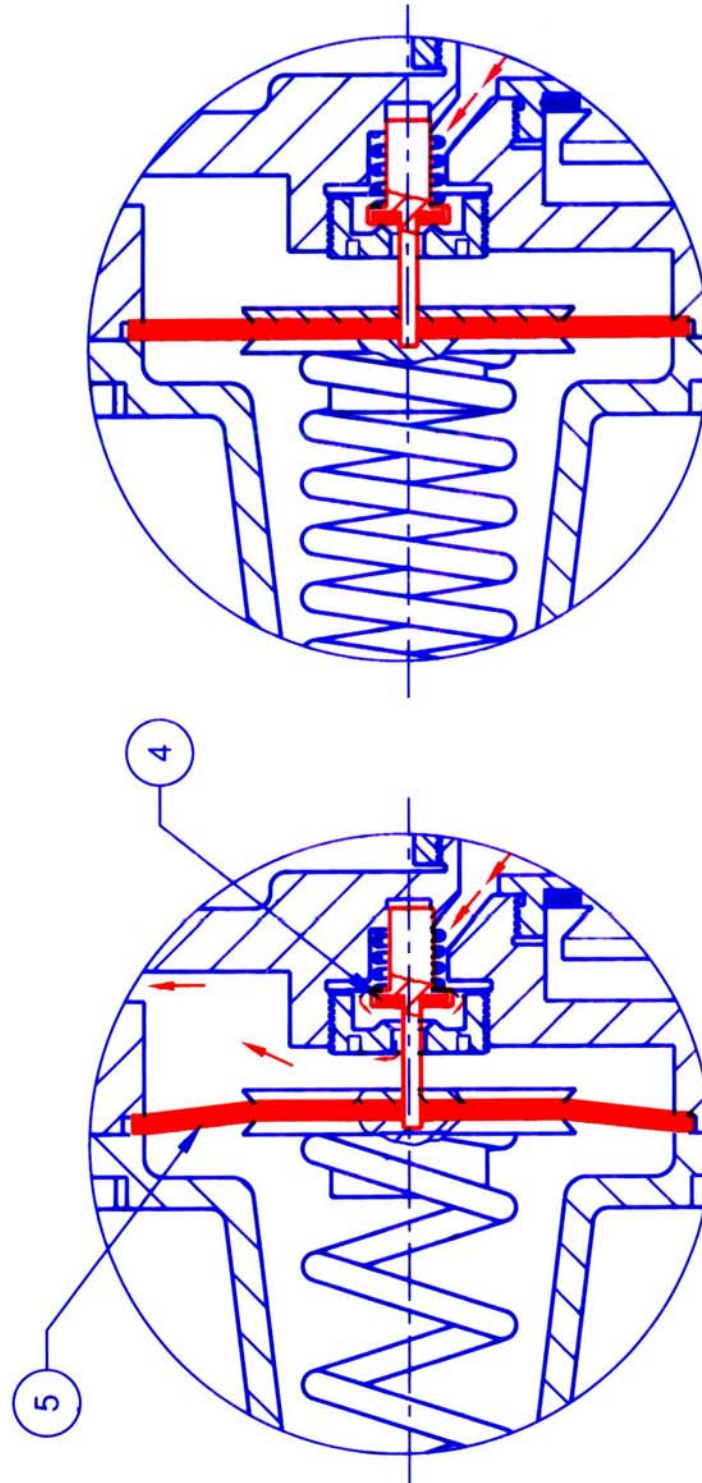



SINGLE STAGE REGULATOR (FUNCTION)

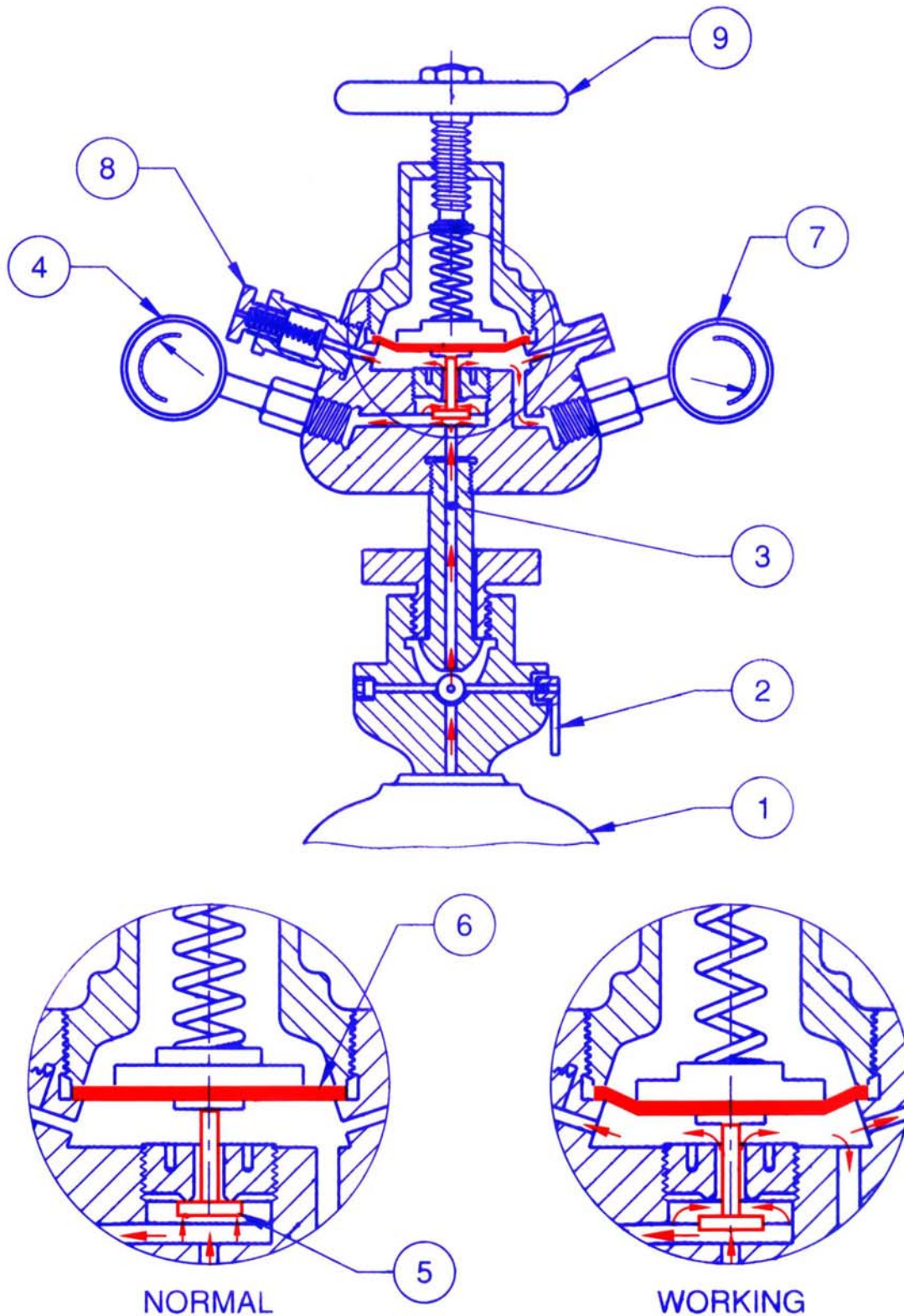

LOW PRESSURE BLOW PIPE (FUNCTION)

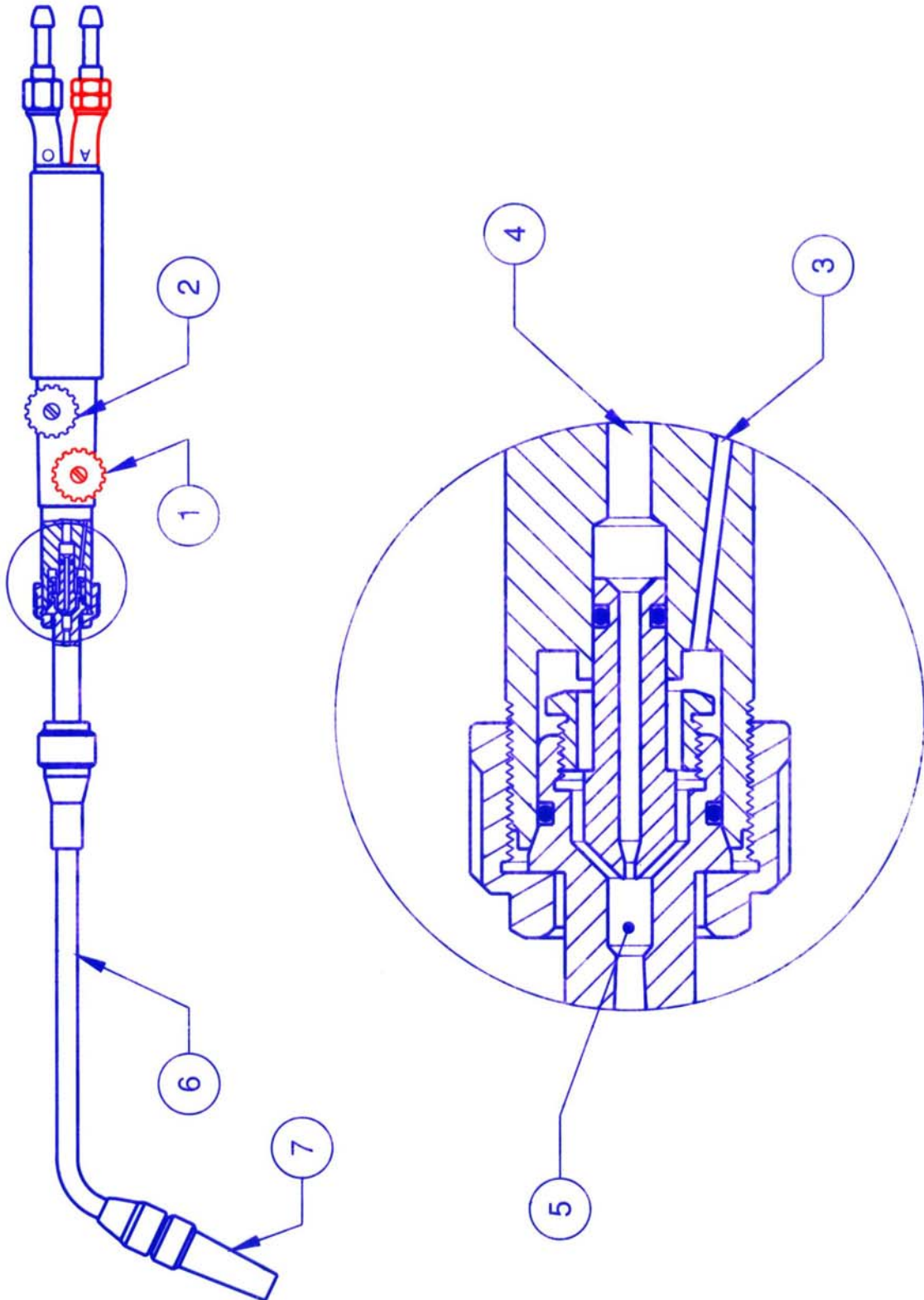



HIGH PRESSURE BLOW PIPE (FUNCTION)

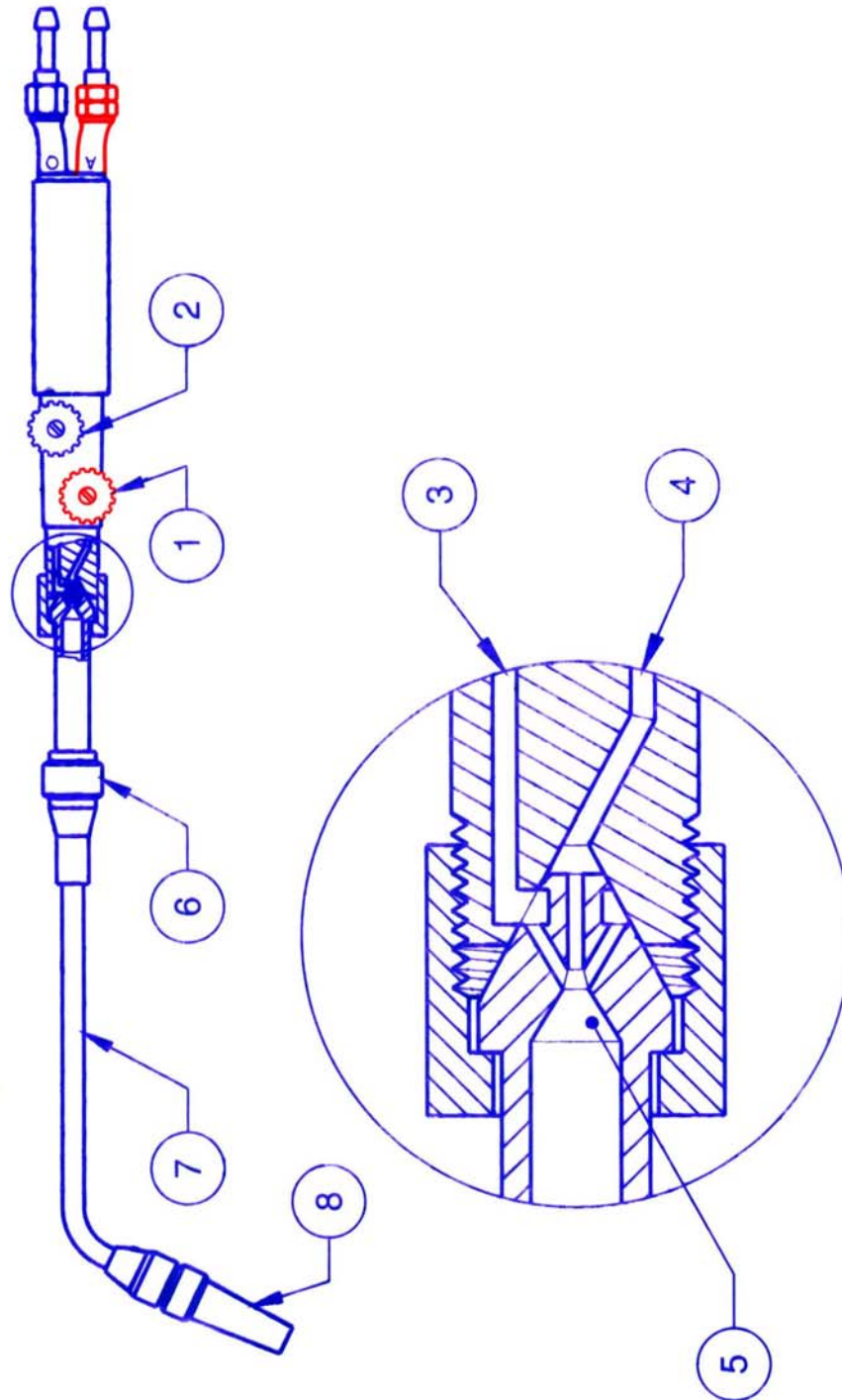



WATER TO CARBIDE GENERATOR (FUNCTION)

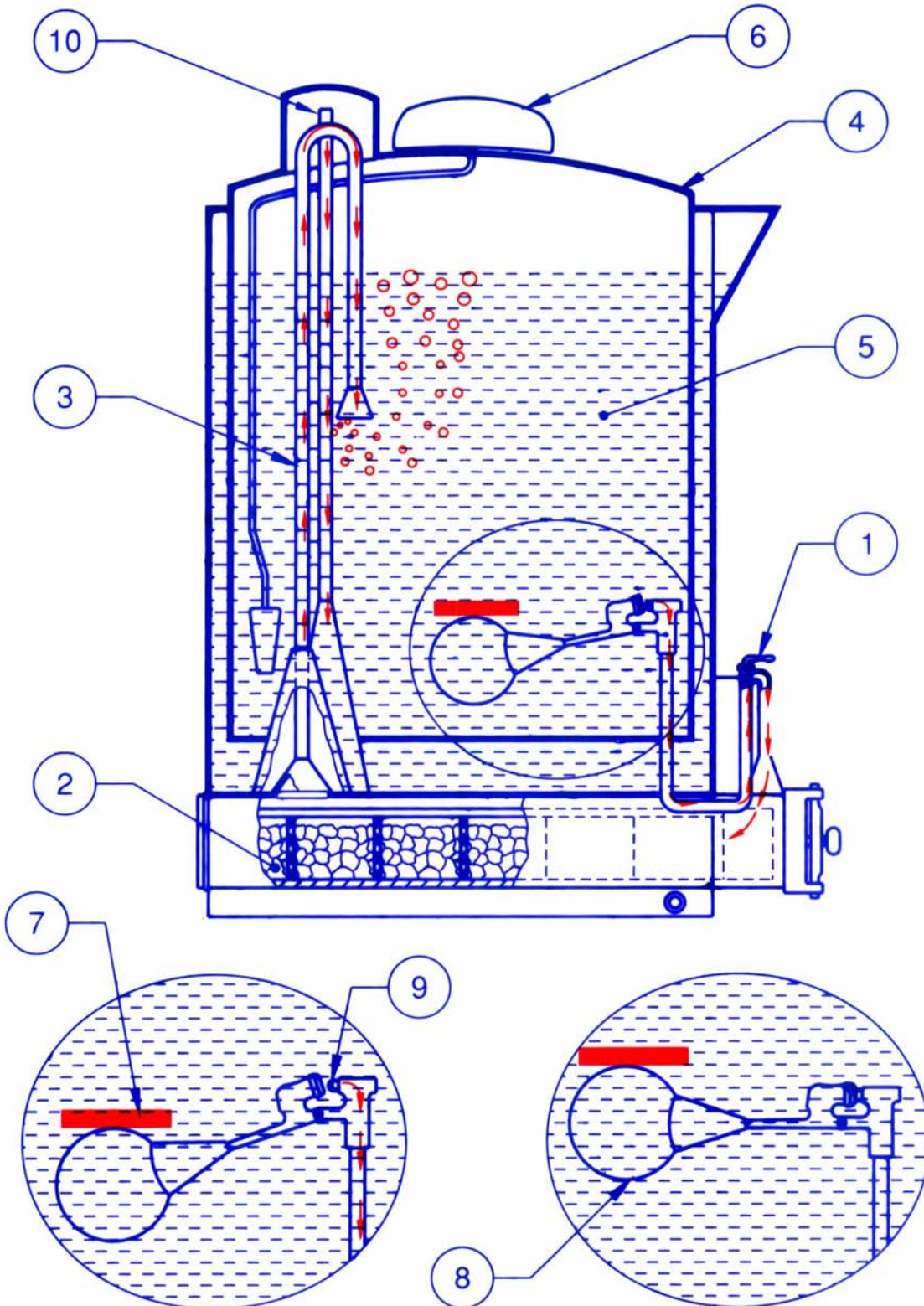



CARBIDE TO WATER GENERATOR (FUNCTION)

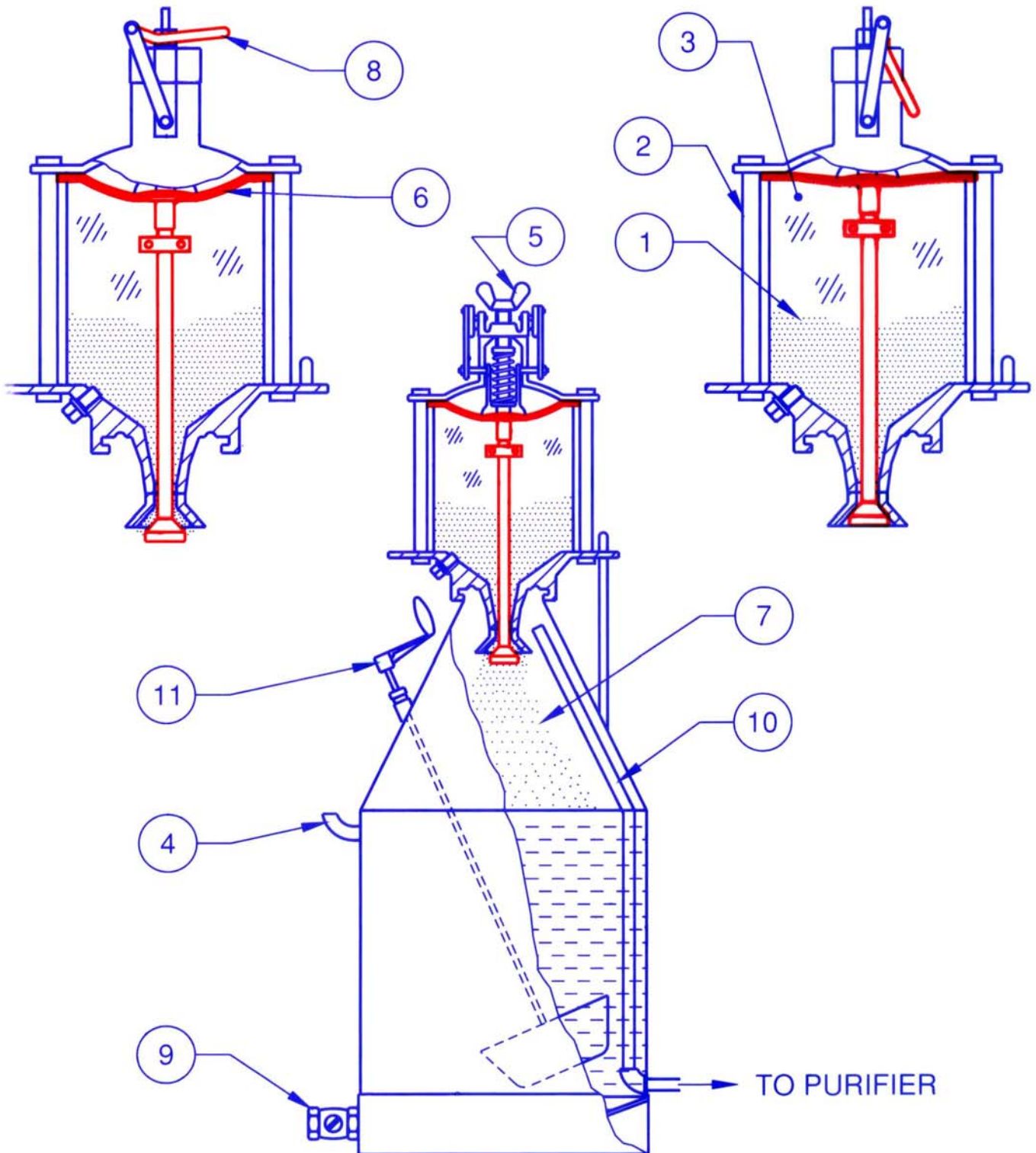



HYDRAULIC BACK PRESSURE VALVE (FUNCTION)

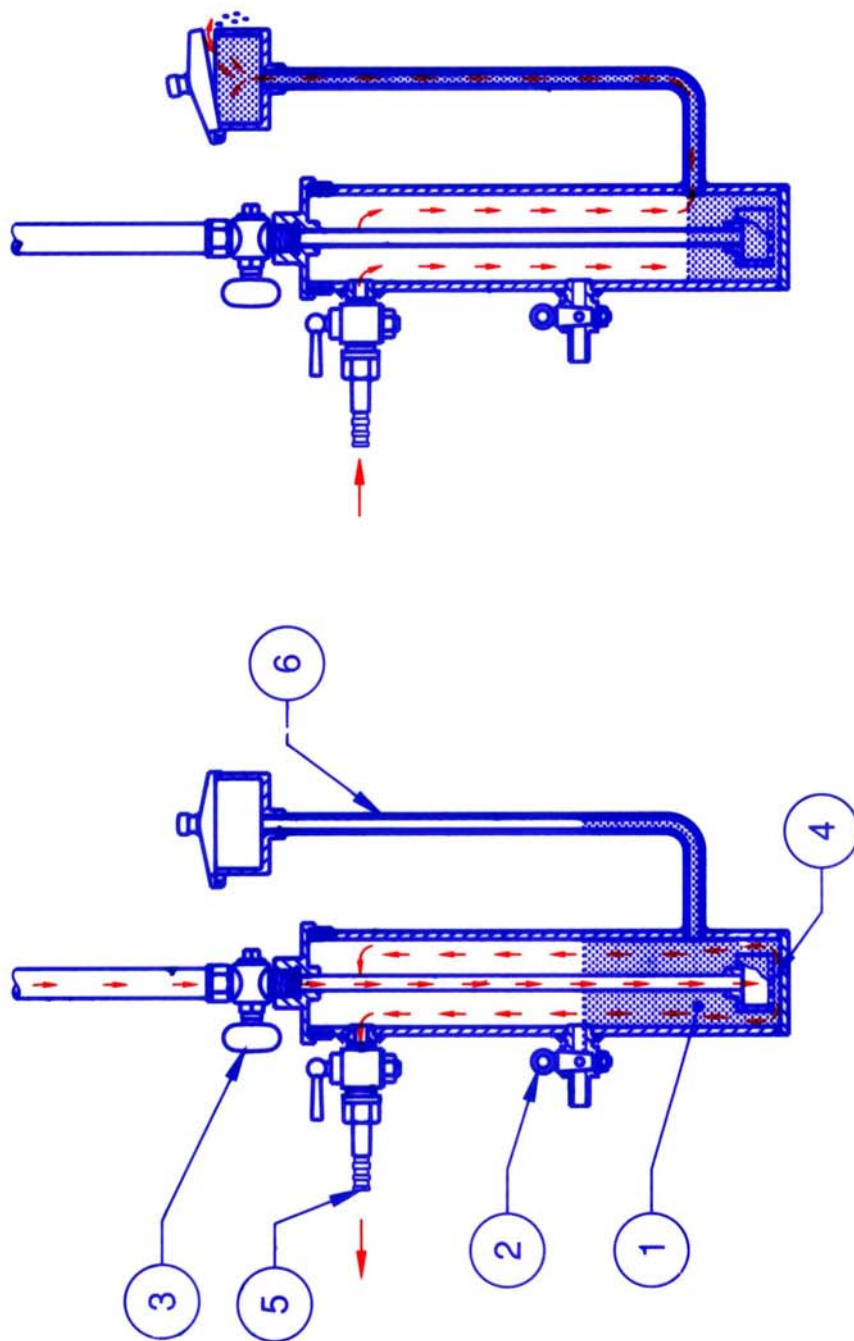



GAS WELDING TECHNIQUES

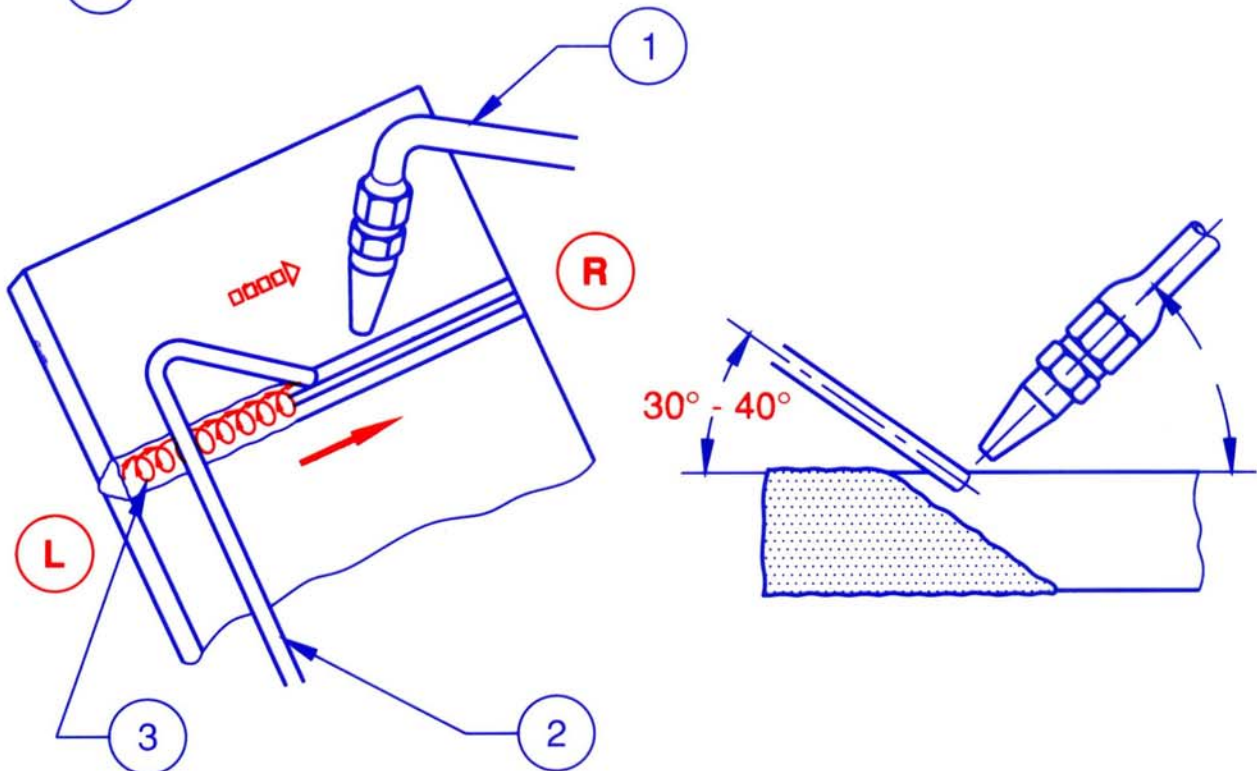
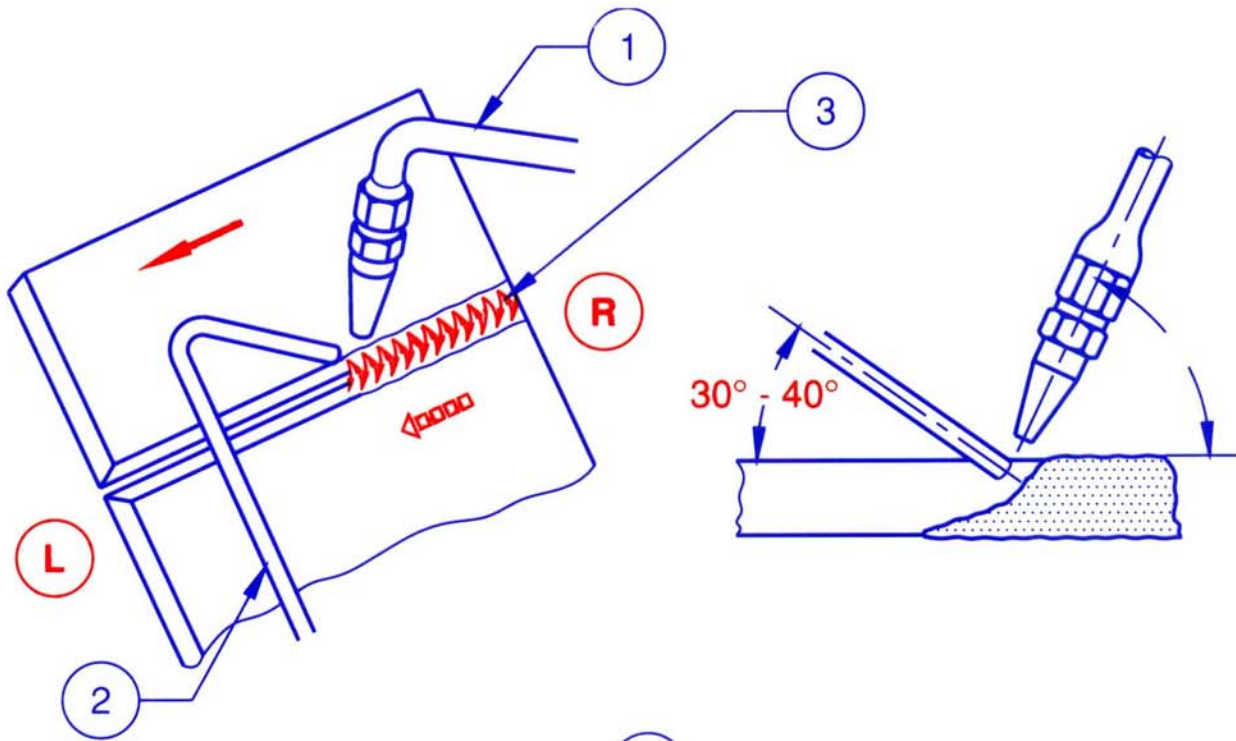



METALLIC ARC

ARC WITH COATED ELECTRODE

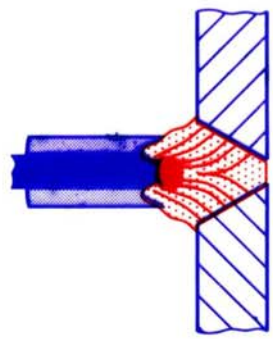

A

ARC WITH BARE ELECTRODE

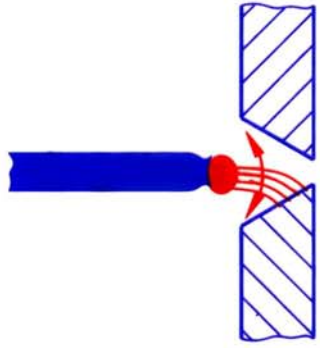

B

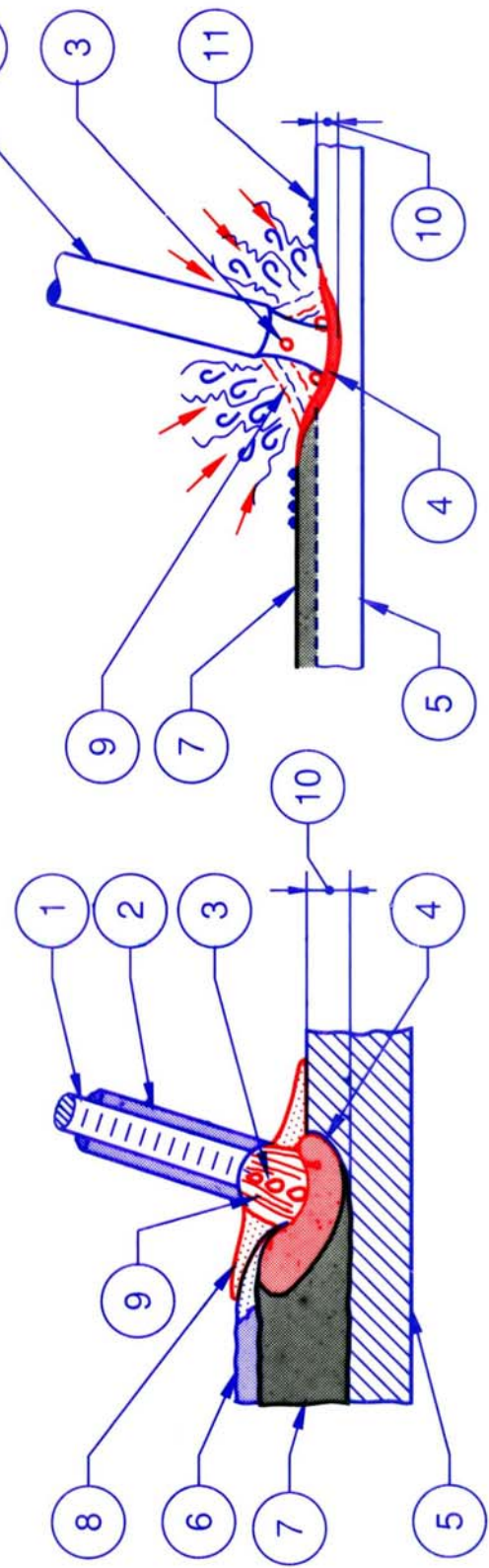

POLARITY AND ITS EFFECTS

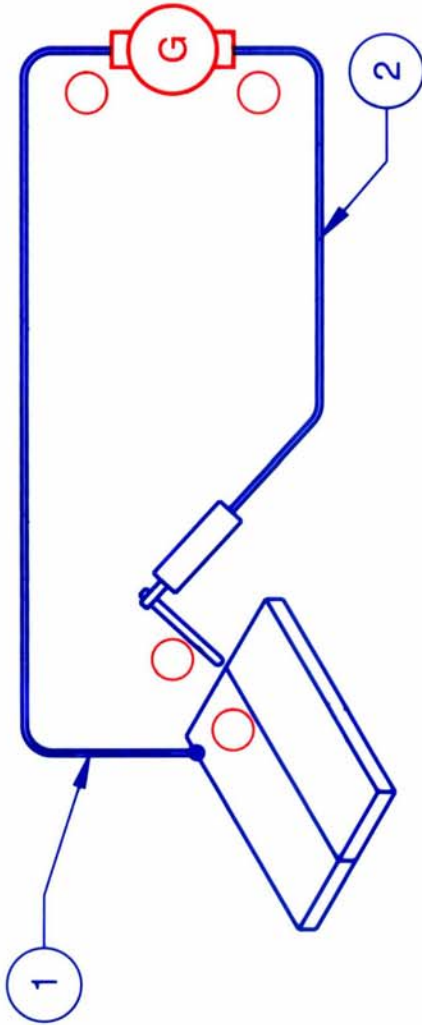
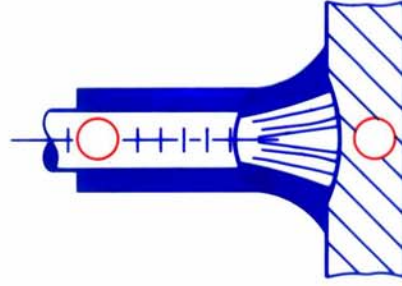
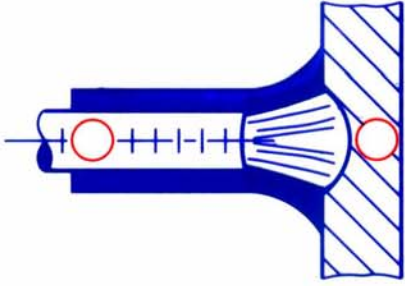

STRAIGHT POLARITY

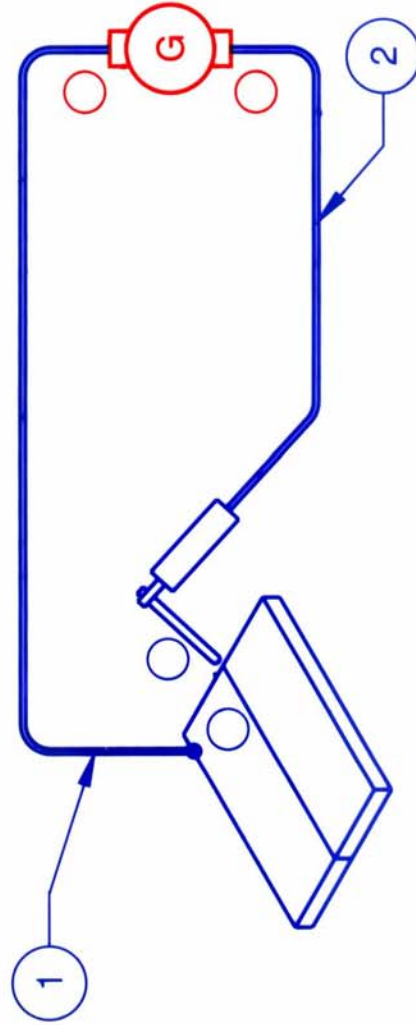

REVERSE POLARITY



NOMENCLATURE OF WELDMENTS

BUTT WELD

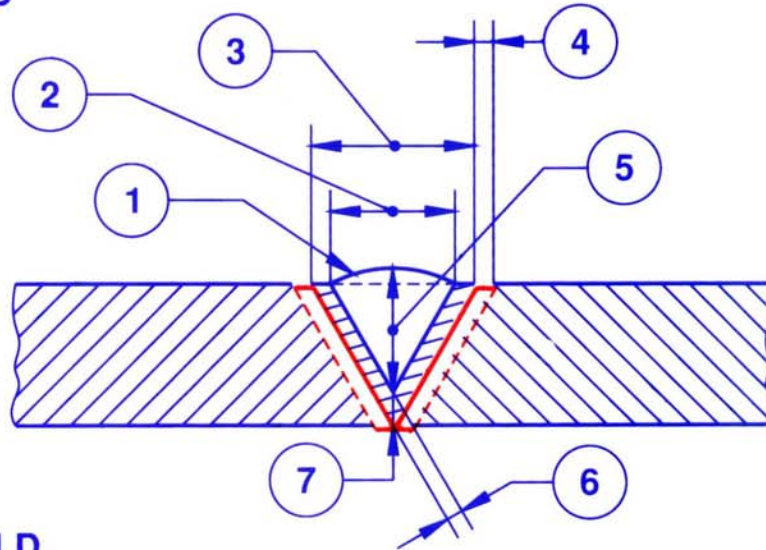

FILLET WELD

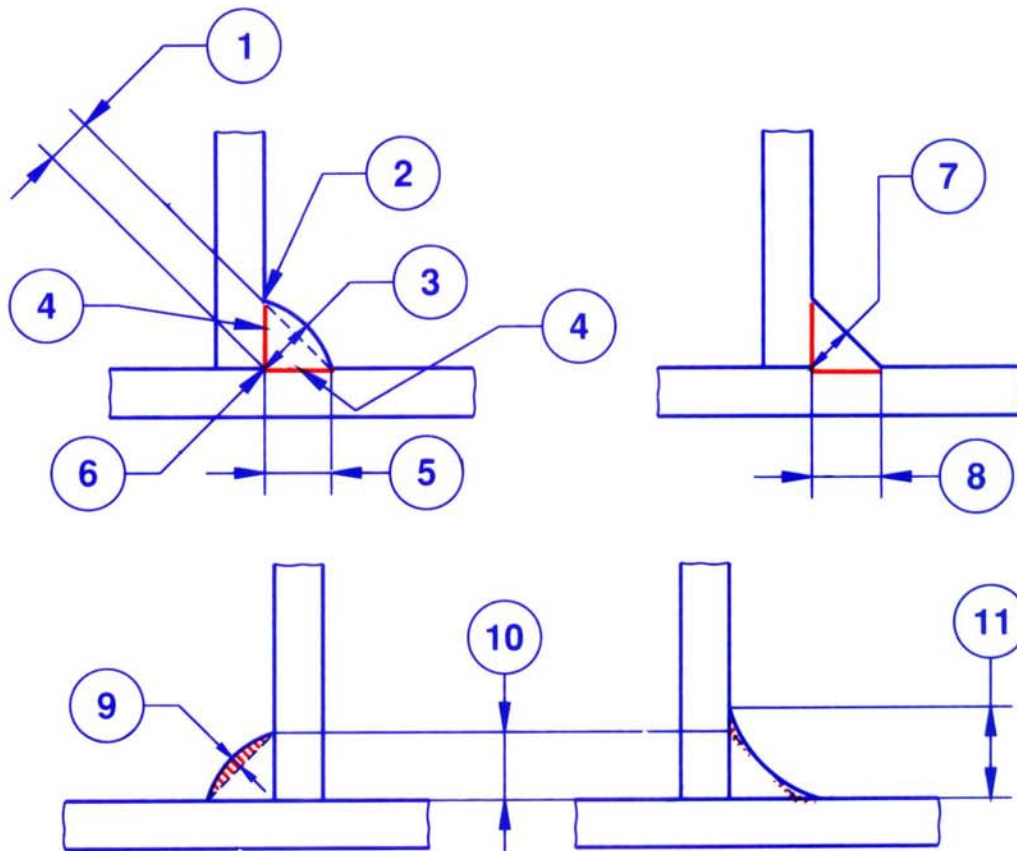



DIFFERENCE BETWEEN FUSION WELDING PROCESSES

GAS WELDING

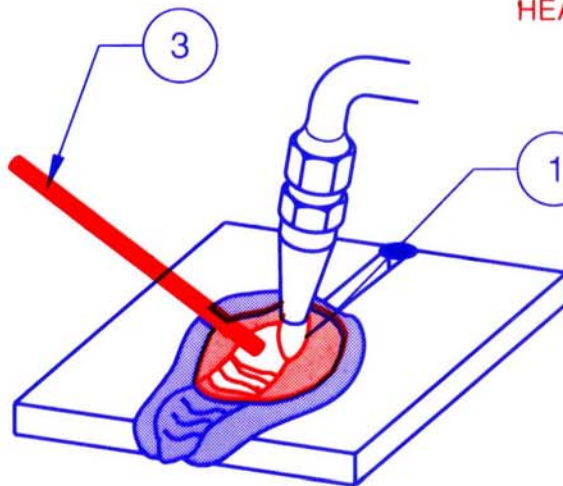

MANUAL ARC WELDING

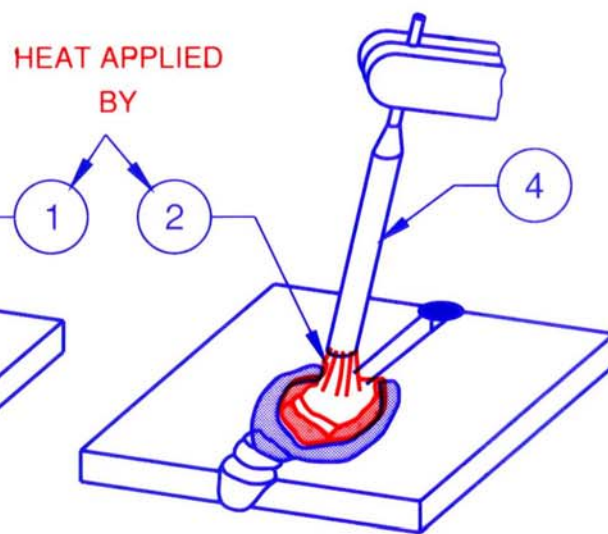

TUNGSTEN INERT GAS WELDING

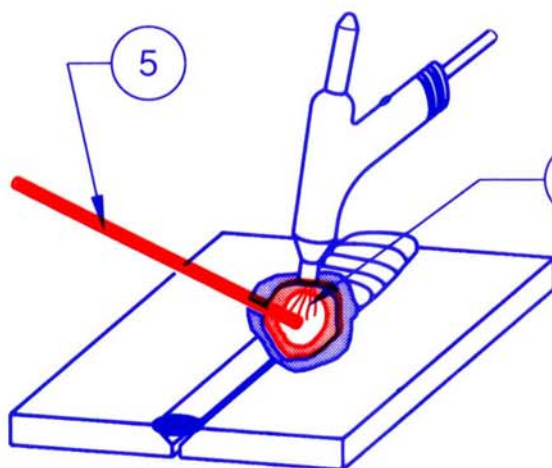

METAL INERT GAS WELDING

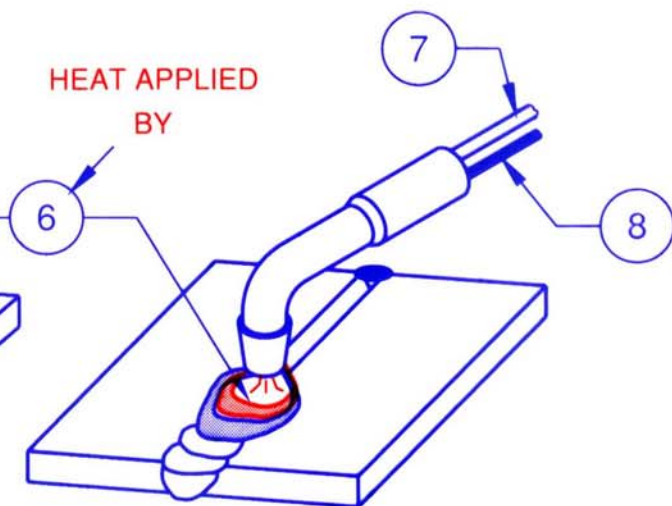

ARC BLOW AND ITS EFFECTS

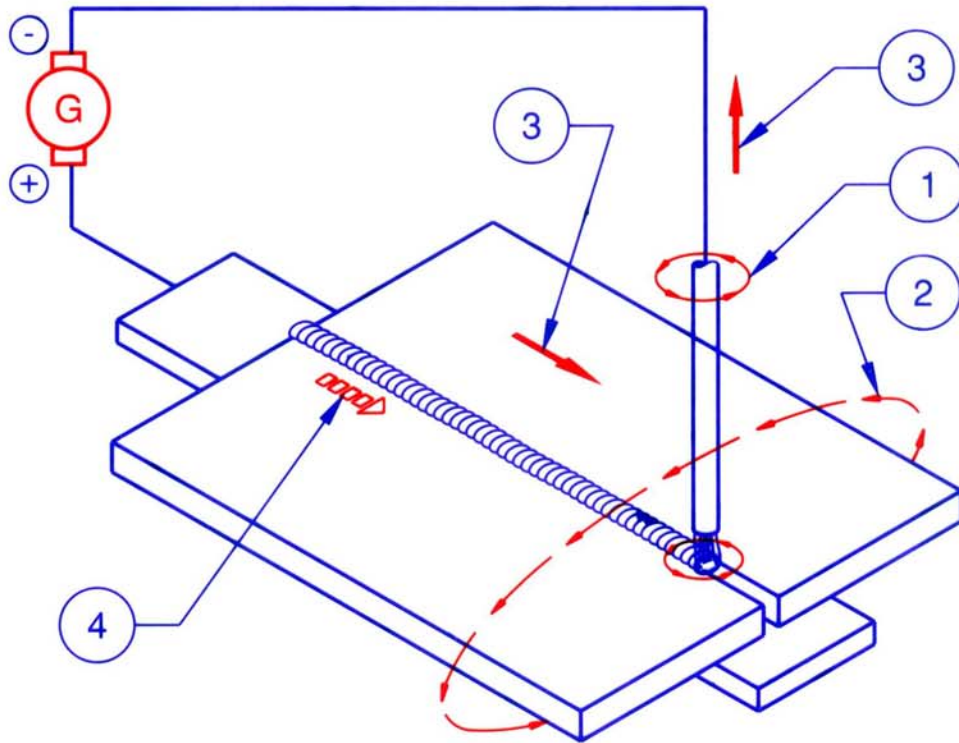

COMMON REASONS FOR THE ARC BLOW EFFECTS IN PARTICULAR WHEN USING DIRECT CURRENT

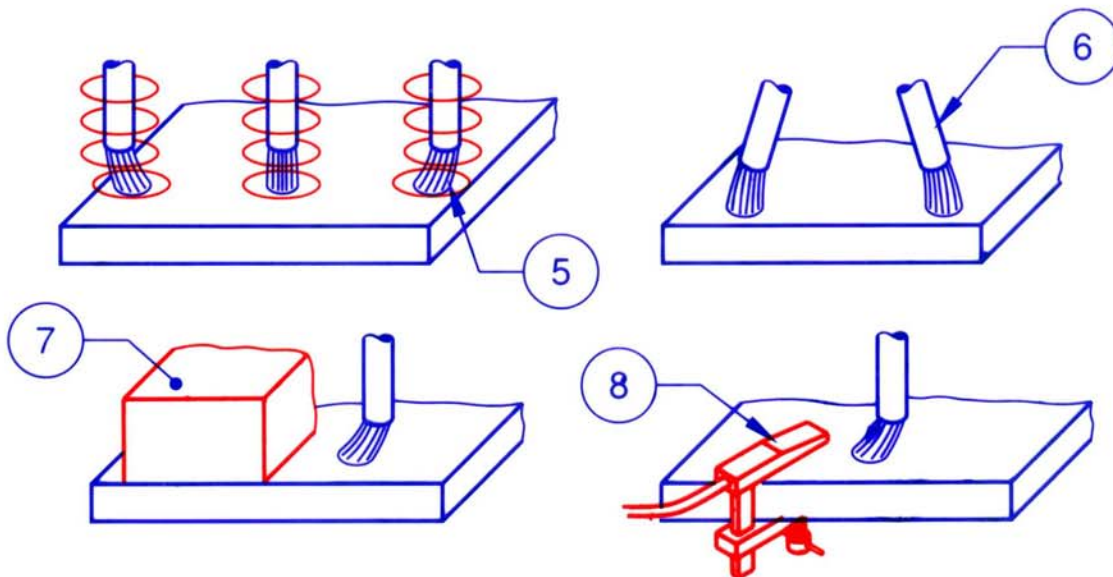



RADIOGRAPHY TEST

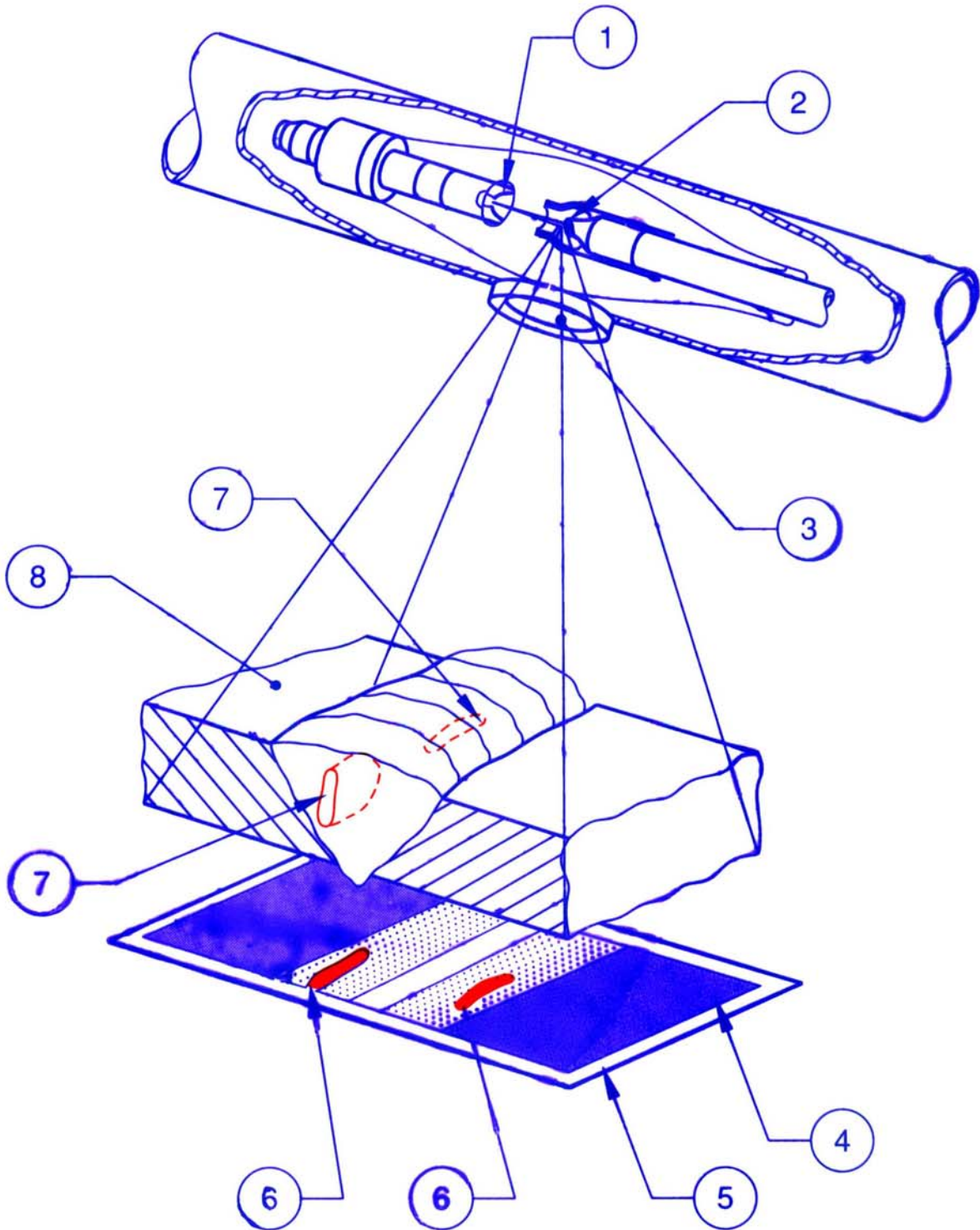



AUTOMATIC SUBMERGED ARC WELDING

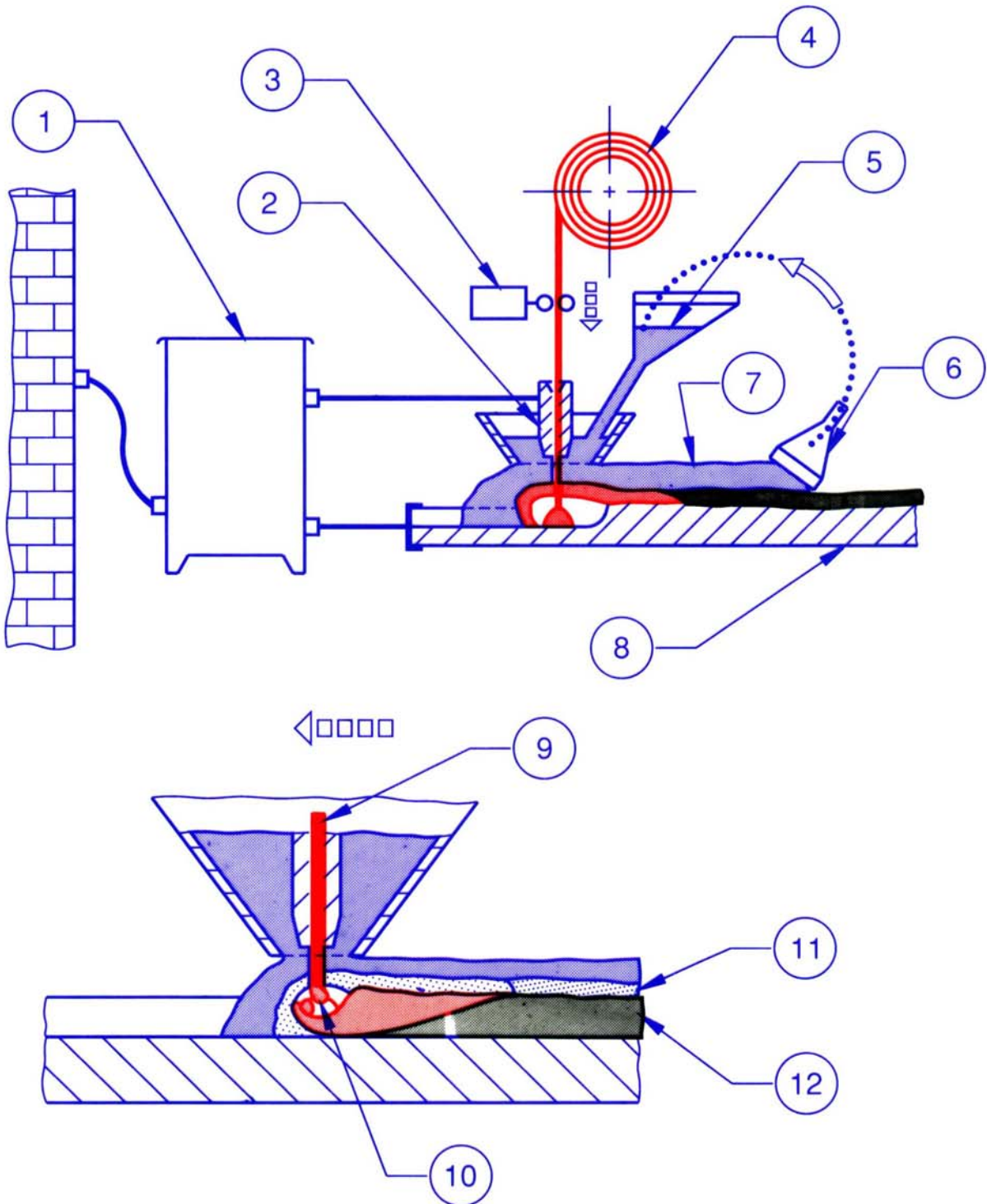



SPOT WELDING

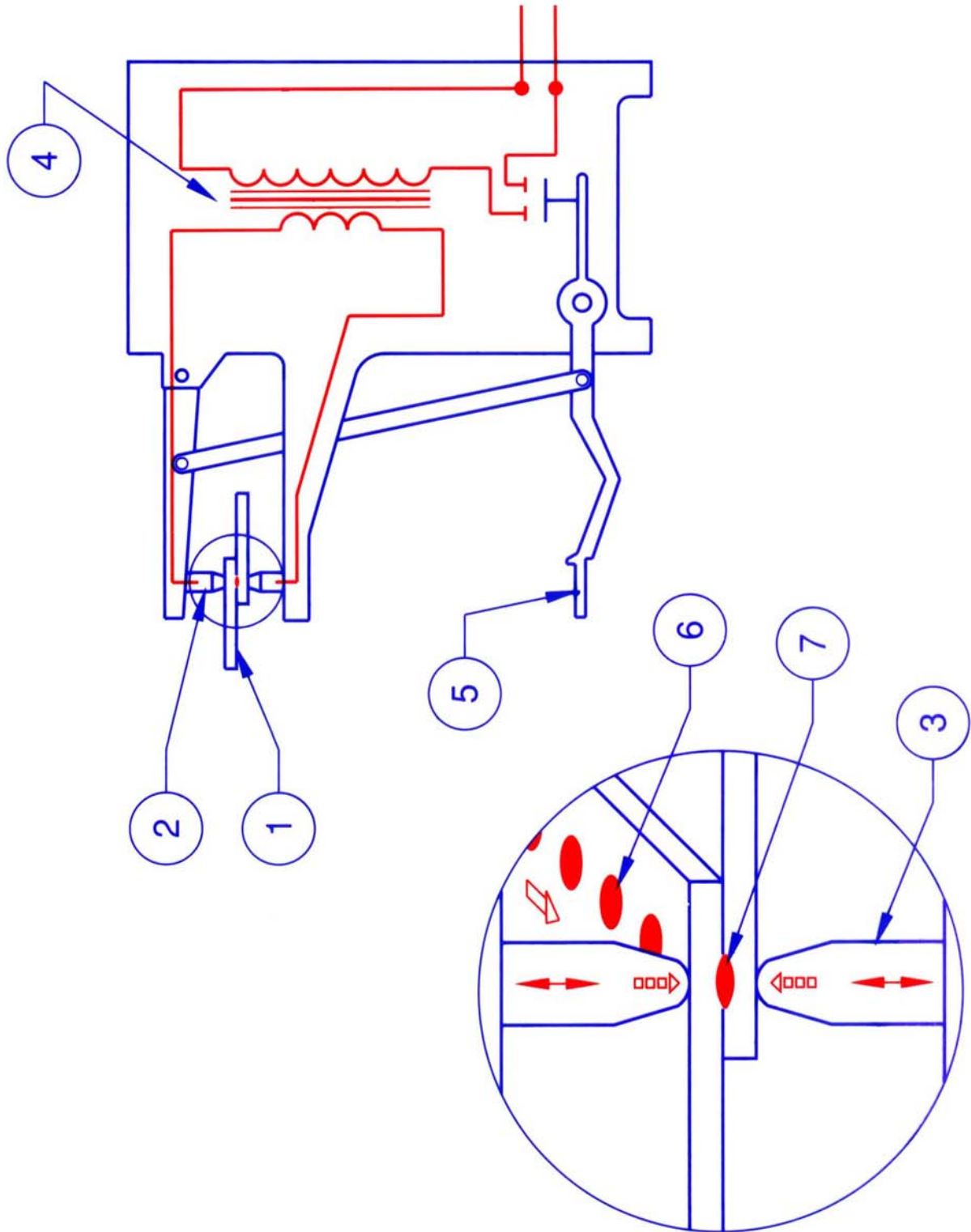



SEAM WELDING

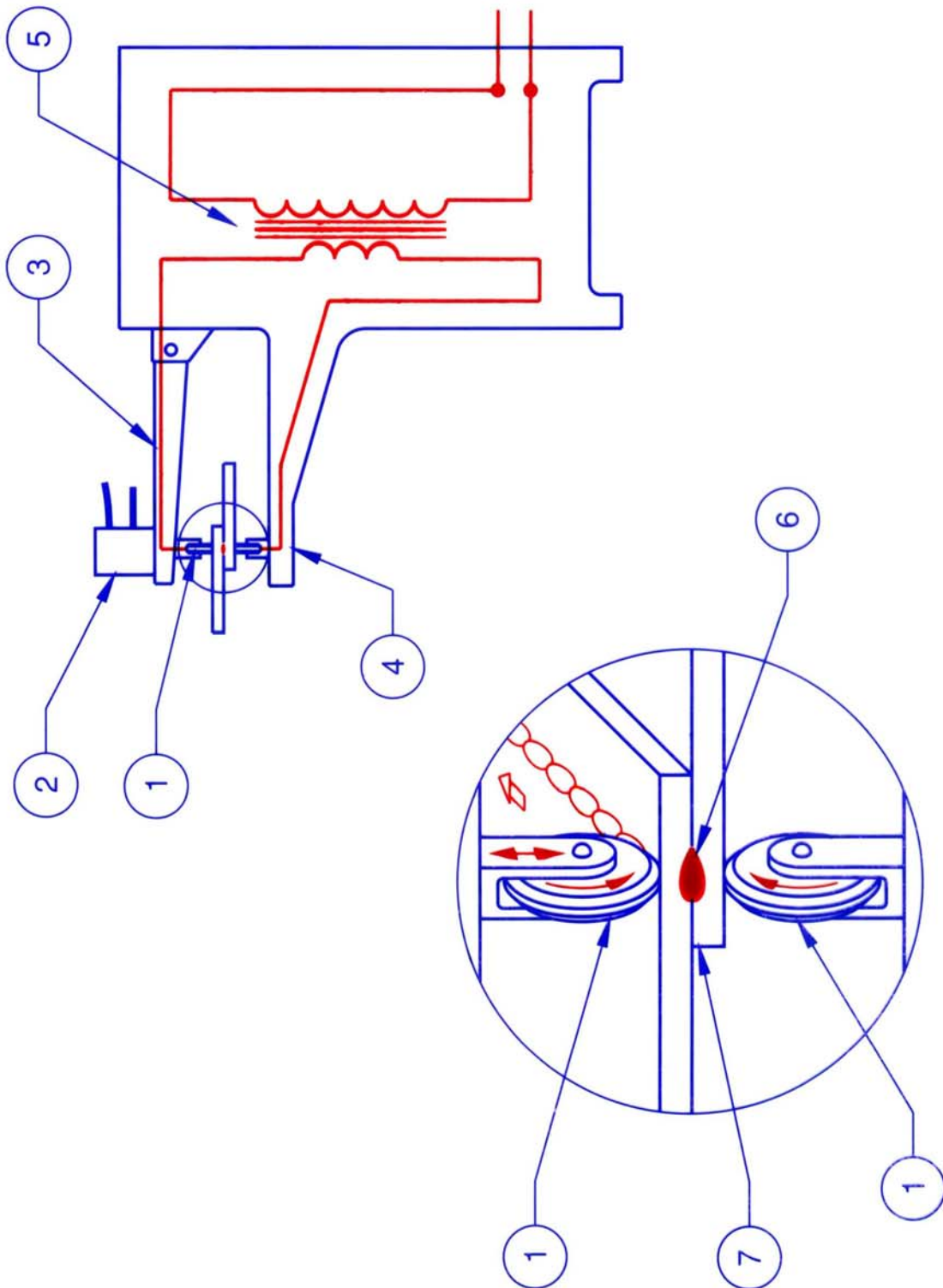

METAL INERT GAS (MIG) WELDING

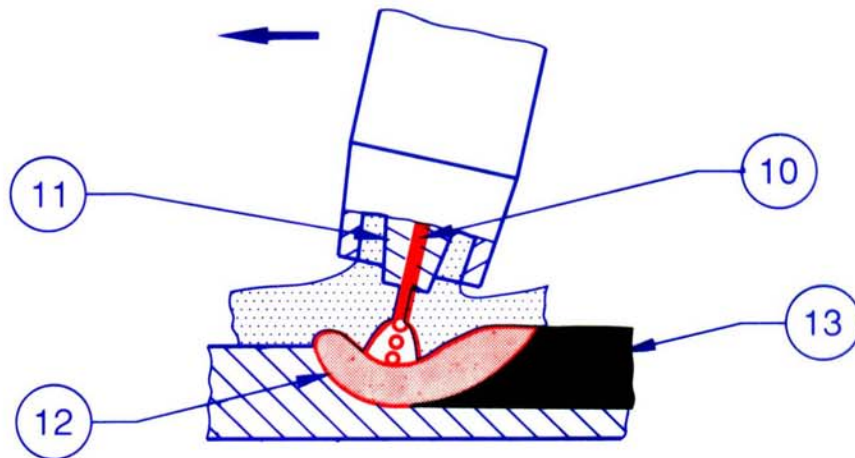
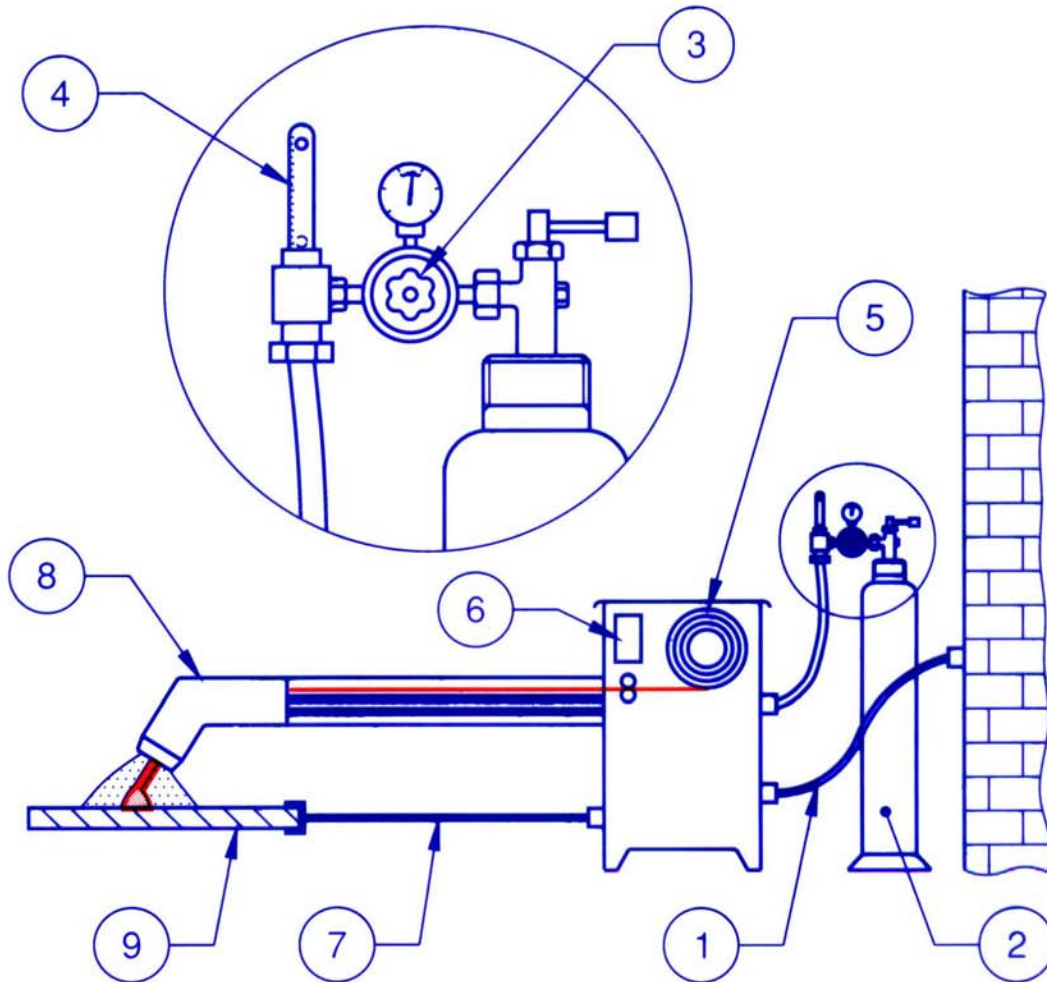

METAL INERT GAS WELDING (MIG) TORCH

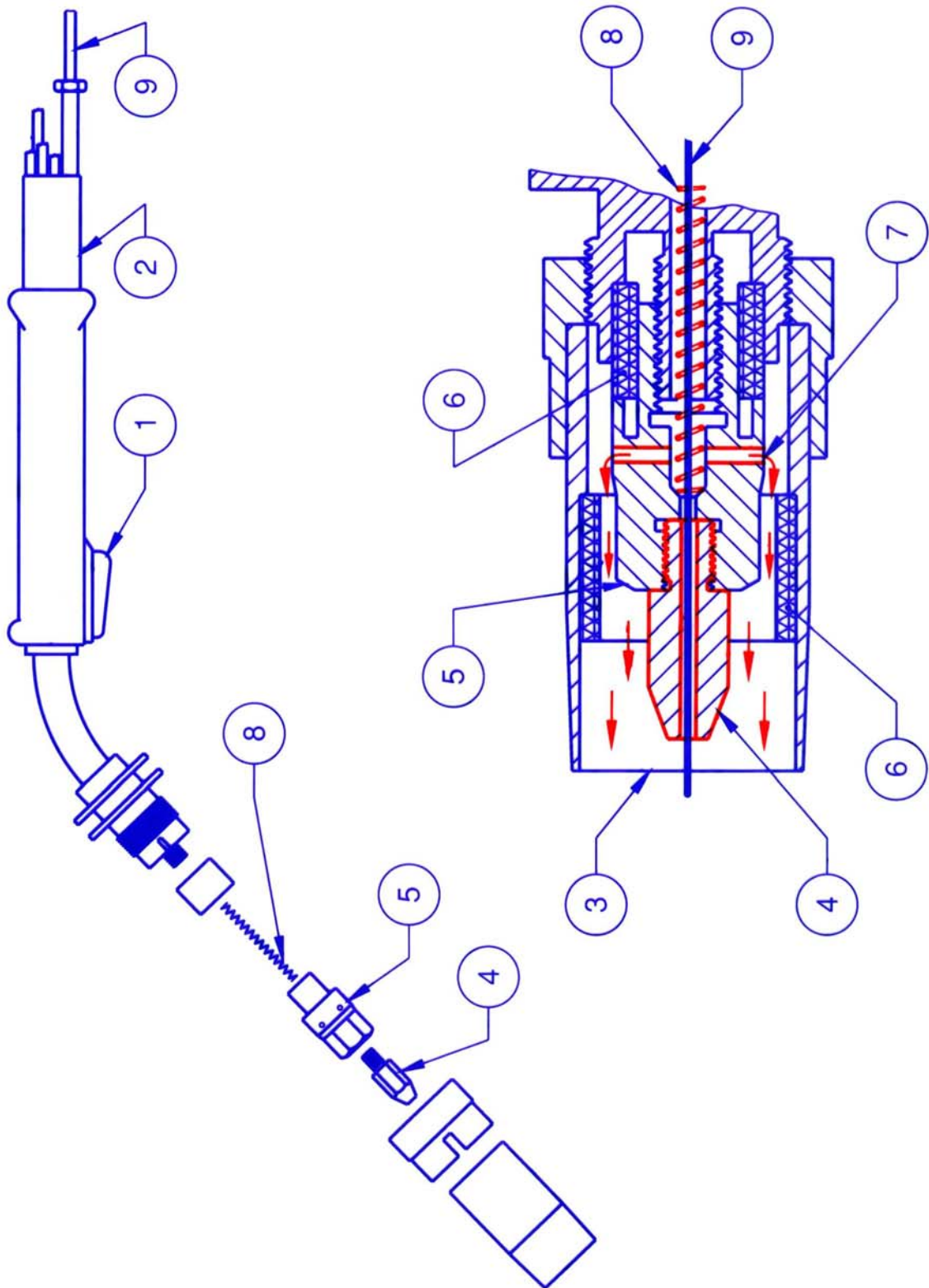

WELDING SYMBOLS

Butt weld between plates
with raised edges (the
raised edges being
melted down completely)

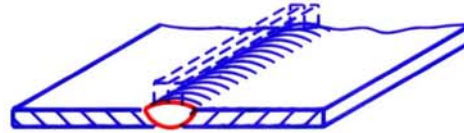

Square butt weld

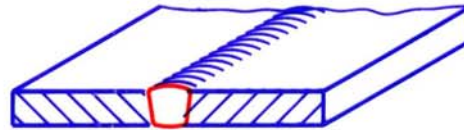

Single V butt weld

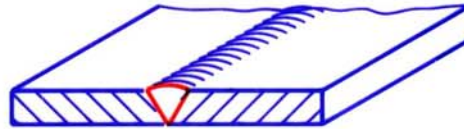

Single bevel butt weld

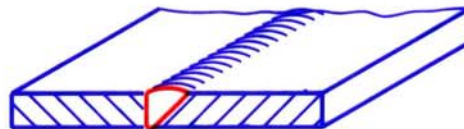

Single V butt weld with
broad root face

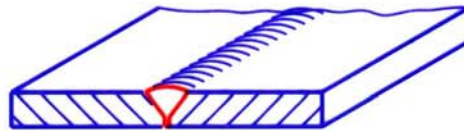

Single bevel butt weld
with broad root face

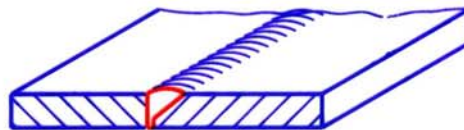

Single U butt weld
(parallel or sloping sides)

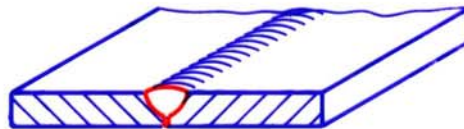

Single J butt weld

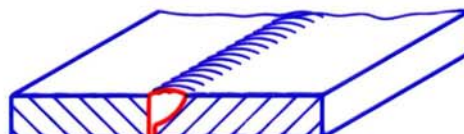



WELDING SYMBOLS

Backing run ; back or
backing weld

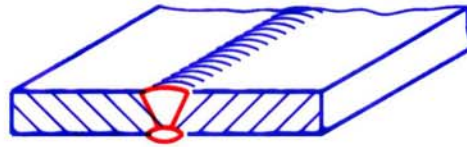

Fillet weld

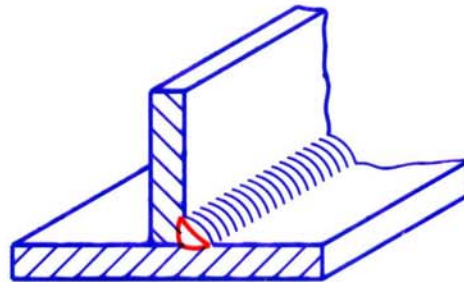

Plug weld ; plug or slot
weld /USA

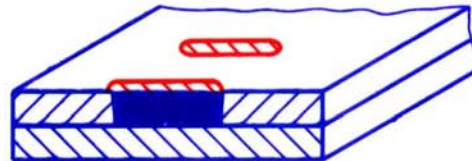

Spot welding

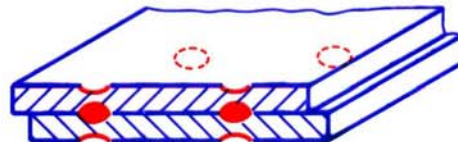

Spot welding

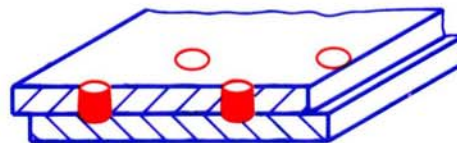

Seam welding

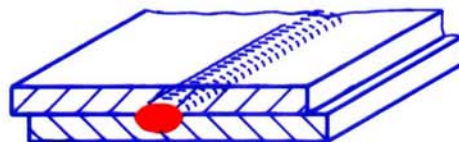

Seam welding

