

[Home](#) > [ar](#).[cn](#).[de](#).[en](#).[es](#).[fr](#).[id](#).[it](#).[ph](#).[po](#).[ru](#).[sw](#)

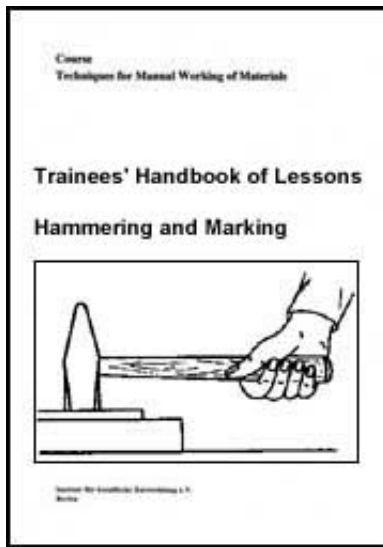

➔ **Hammering and Marking - Course: Technique for manual working of materials. Trainees' handbook of lessons (Institut fr Berufliche Entwicklung, 17 p.)**

📄 **(introduction...)**

- 📄 **1. Purpose of hammering and marking**
- 📄 **2. Tools and accessories**
- 📄 **3. Working principle of hammering**
- 📄 **4. Working techniques of hammering**
- 📄 **5. Working technique of marking**
- 📄 **6. Labour safety recommendations**



[Home](#) > [ar](#).[cn](#).[de](#).[en](#).[es](#).[fr](#).[id](#).[it](#).[ph](#).[po](#).[ru](#).[sw](#)

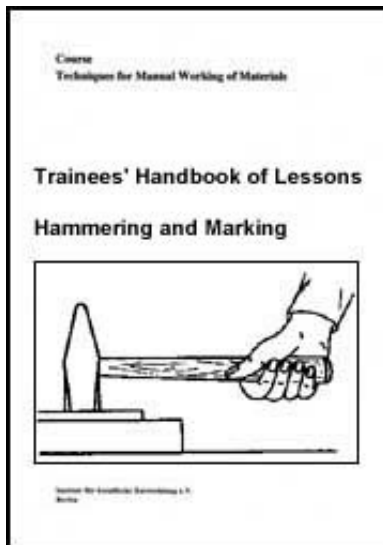

📖 **Hammering and Marking - Course: Technique for manual working of materials. Trainees' handbook of lessons (Institut fr Berufliche Entwicklung, 17 p.)**

➔ 📄 **(introduction...)**

- 📄 **1. Purpose of hammering and marking**
- 📄 **2. Tools and accessories**
- 📄 **3. Working principle of hammering**
- 📄 **4. Working techniques of hammering**
- 📄 **5. Working technique of marking**

 **6. Labour safety recommendations**

**Institut fr berufliche Entwicklung e.V.
Berlin**

**Original title:
Arbeitsmaterial fr den Lernenden
"Hmmern und Kenzeichen"**

Author Frank Wenghfer

First edition © IBE

**Institut fr berufliche Entwicklung e.V.
Parkstrae 23
13187 Berlin**

Order No.: 90-35-3103/2







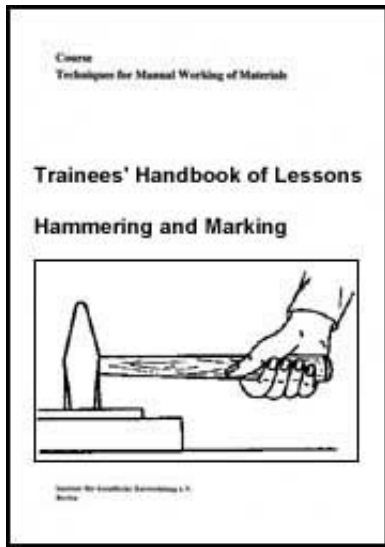

[Home](#) > [ar](#).[cn](#).[de](#).[en](#).[es](#).[fr](#).[id](#).[it](#).[ph](#).[po](#).[ru](#).[sw](#)

 **Hammering and Marking - Course: Technique for manual working of materials. Trainees' handbook of lessons (Institut fr Berufliche Entwicklung, 17 p.)**

 **(introduction...)**



- ➔  **1. Purpose of hammering and marking**
-  **2. Tools and accessories**
-  **3. Working principle of hammering**
-  **4. Working techniques of hammering**
-  **5. Working technique of marking**
-  **6. Labour safety recommendations**

1. Purpose of hammering and marking

Hammering is a technique of forming or straightening workpieces or increasing their strength and hardness by means of well-aimed hammer blows on sheet metal and sections.

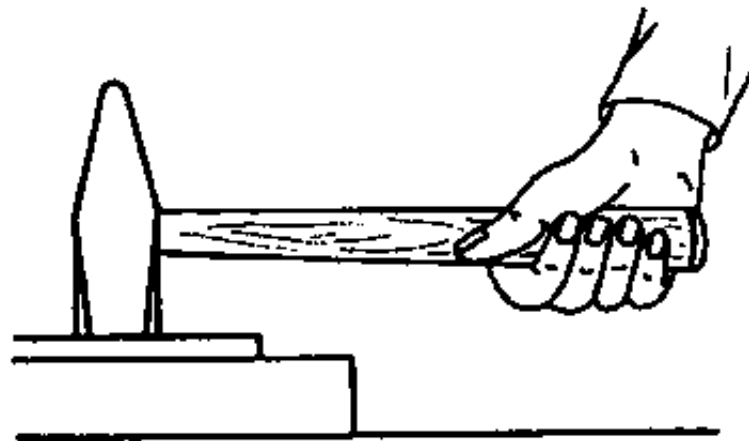

Figure 1 Hammering

It is used in single-piece production only, in special industries and trades or repair work.

Special hammering techniques are: lengthening, curving, chasing, flanging.

Marking is a technique of punching - by means of hammers and special marking punches - letters, figures or texts into the surface of workpieces for the purpose of identifying workpieces, giving sequences for assembly operations or durably noting down dates of manufacture.

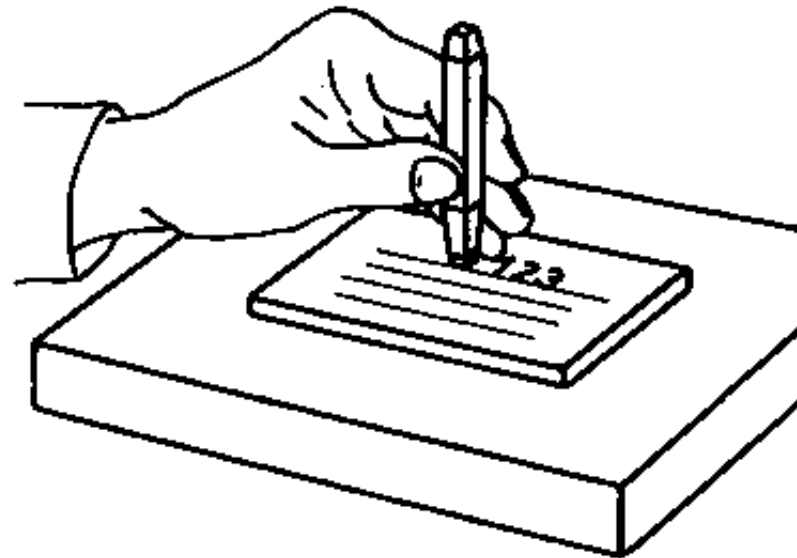
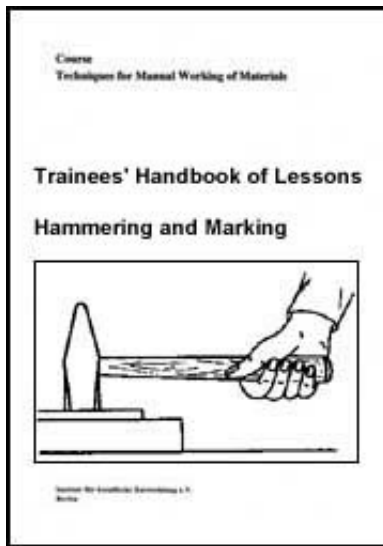

Figure 2 Marking

In modern batch or mass production such operations are performed on special machines by means of pressing, deep-drawing, bending and embossing tools





 **Hammering and Marking - Course: Technique for manual working of materials. Trainees' handbook of lessons (Institut fr Berufliche Entwicklung, 17 p.)**

 **(introduction...)**

 **1. Purpose of hammering and marking**

 **2. Tools and accessories**

 **3. Working principle of hammering**

 **4. Working techniques of hammering**

 **5. Working technique of marking**

 **6. Labour safety recommendations**

2. Tools and accessories

Main hammering tool is the hammer of various types.

Engineers' hammer

The hammer head is made of tough tool steel with hardened and ground face (2) and pane (4).

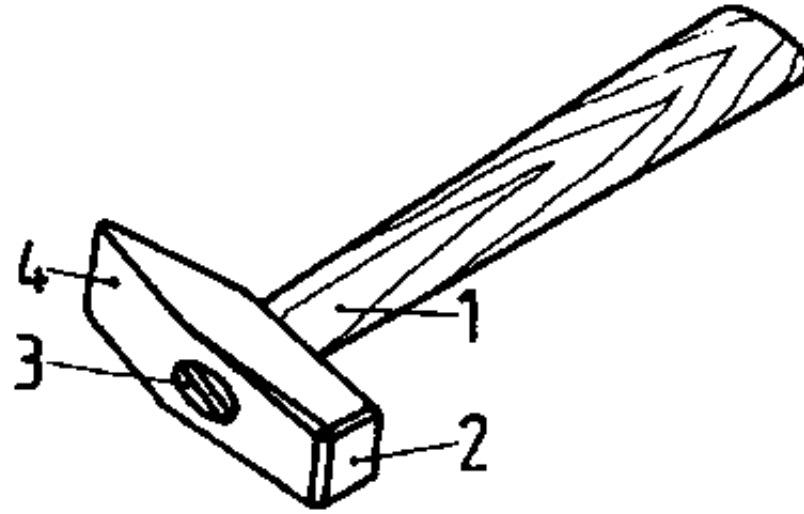

Figure 3 Engineers' hammer

The hammer handle (1) is made of strong and elastic wood and fixed to the hammer head by means of a cotter (3) in oblique position.

Different hammers are used, depending on the size of the workpiece and the purpose of use:

- Riveting hammer (50 g - 200 g),
used for smaller workpieces.**
- Hand hammer (200 g - 400 g),
widely used for various fitting purposes.**
- Bench hammer (400 g - 2000 g),
used for massive workpieces.**

Special hammers for sheet metal working:

**- Chasing hammer (250 g - 500 g),
ball face hammer for chasing of thin sheet metal.**

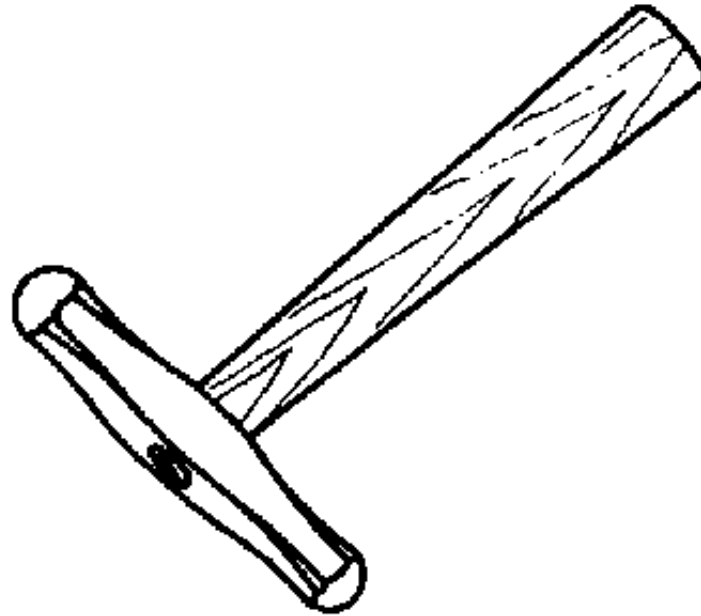

Figure 4 Chasing hammer

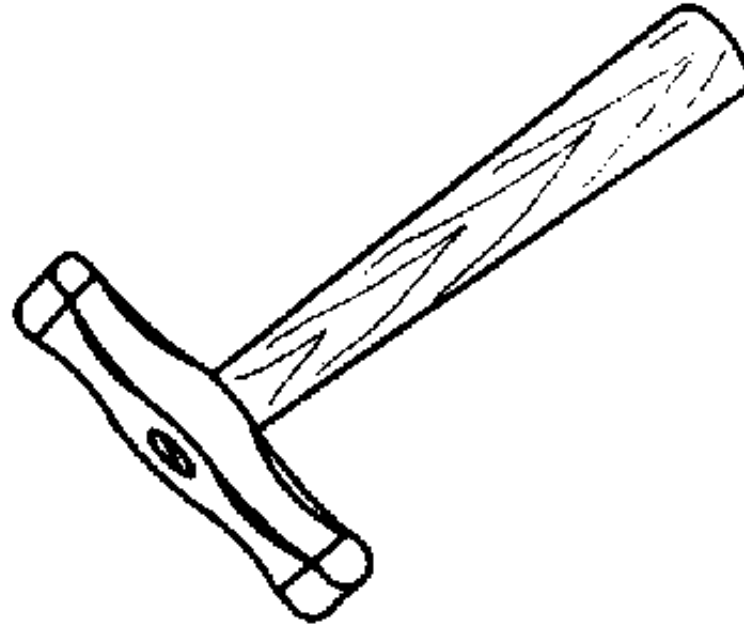

Figure 5 Curving hammer

- **Curving hammer (250 g - 750 g), barrel face hammer for notchless curving of sheet metal strips.**
- **Finishing hammer (250 g - 500 g) and smoothing hammer (350 g - 1000 g), flat or oval face hammers for planishing of faces.**
- **Wooden hammer (170 g - 500 g), rubber and aluminium hammers:**

Hammers not damaging the surface of the sheet metal during forming and straightening operations.

For special purposes, wooden hammers may be bevelled or radiused.

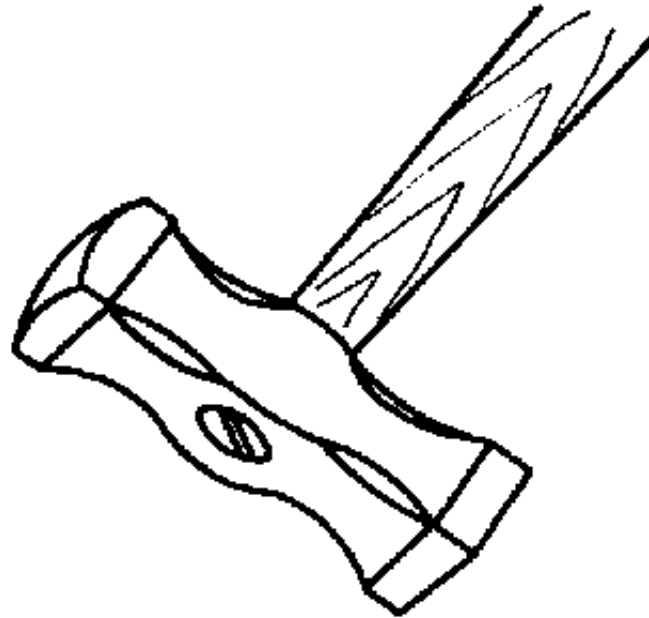

Figure 6 Finishing hammer

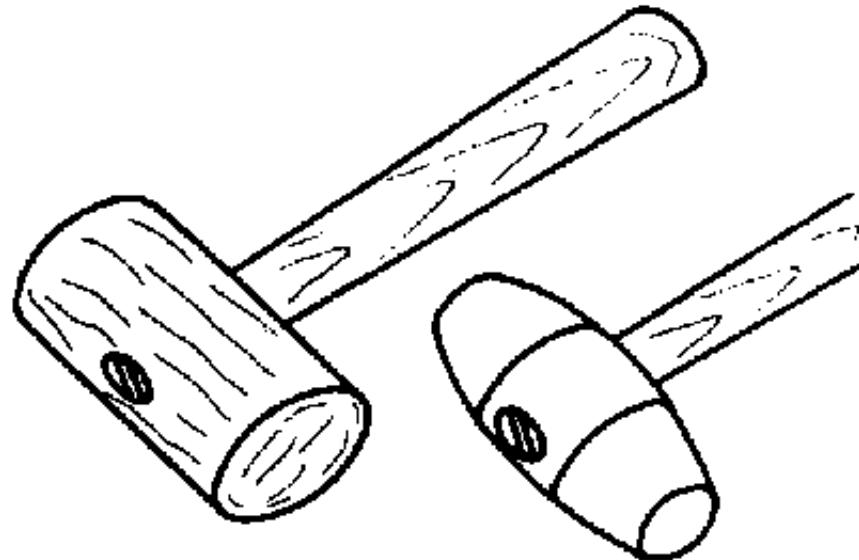

Figure 7 Wooden hammer and aluminium hammer

Hammering supports:

- Surface plates

Strong and flat cast-steel plates which are held by a stand or put on a work bench and are used for most hammering work.

Surface plates must not be damaged by chisel cuts!

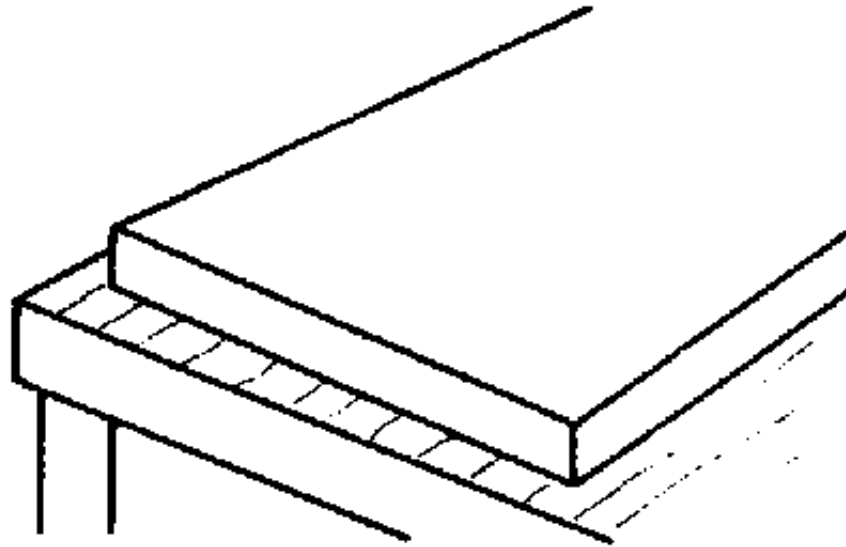

Figure 8 Surface plate

- Blacksmiths' anvil

Hardened support with face (2), round horn (1) and flat horn (3) for various forming and straightening operations.

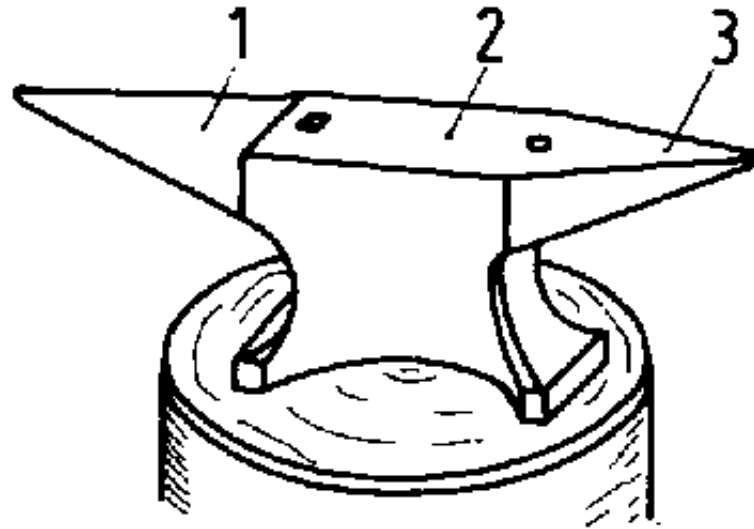

Figure 9 Blacksmiths' anvil

Special supports for sheet metal working

- Anvil tool

Flat surface of small size.

- Blacksmiths' double face sledge

Differently convex surfaces of small size.

- Blacksmiths' hardy and bordering tool

Differently shaped faces and edges, specifically for flanging work.

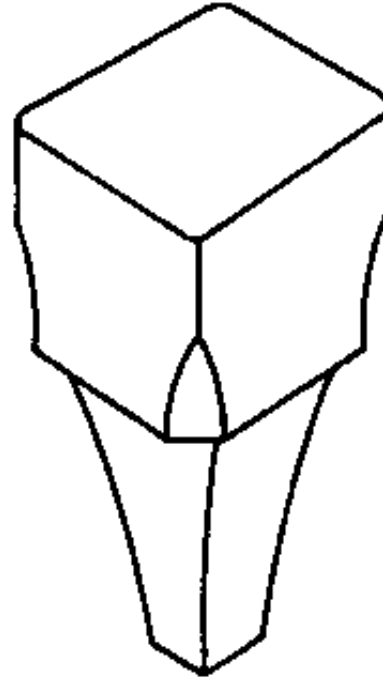

Figure 10 Anvil tool

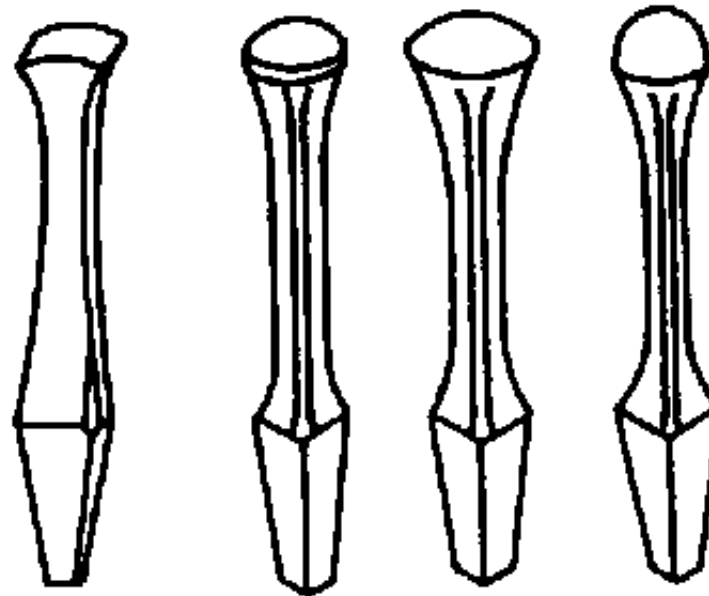

Figure 11 Blacksmiths' double face sledge

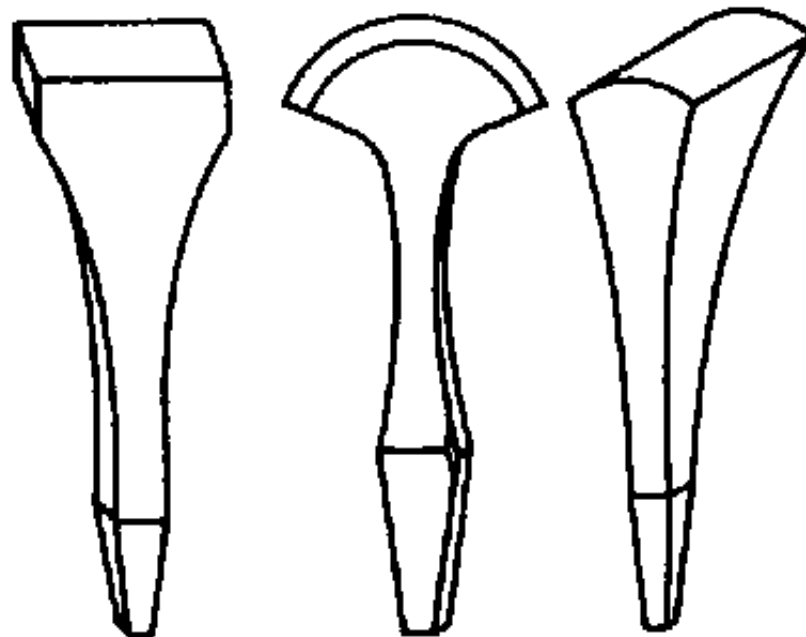

Figure 12 Blacksmiths' hardy and bordering tool

Main marking tool is the marking punch.

- Letter set

Set of marking punches of all alphabetic letters.

- Figure set

Set of marking punches of the figures 0 - 9.

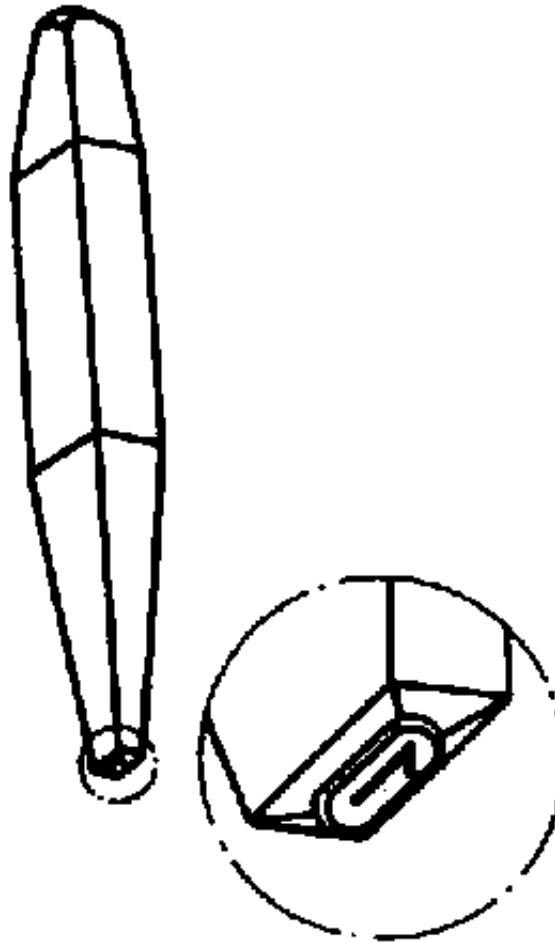

Figure 13 Marking punch (figure 1)

- Special number and word punches

Marking punches of groups of figures or complete words for special requirements.

What makes the difference between engineers' hammers and hammers for sheet metal working?

Which properties are typical of hammering supports?

Which supports are meeting the general requirements of hammering?

What types of marking punches are in use?



[Home](#) > [ar](#).[cn](#).[de](#).[en](#).[es](#).[fr](#).[id](#).[it](#).[ph](#).[po](#).[ru](#).[sw](#)

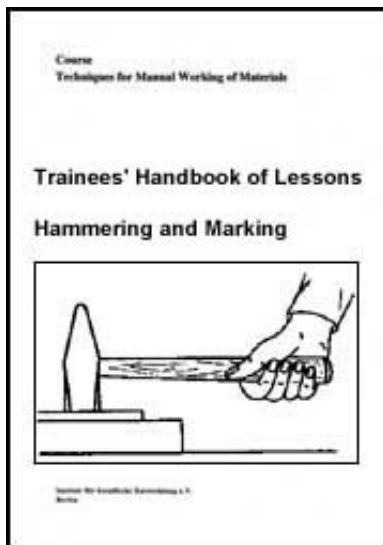

 **Hammering and Marking - Course: Technique for manual working of materials. Trainees' handbook of lessons (Institut fr Berufliche Entwicklung, 17 p.)**

 **(introduction...)**

 **1. Purpose of hammering and marking**

 **2. Tools and accessories**

 **3. Working principle of hammering**

 **4. Working techniques of hammering**

 **5. Working technique of marking**

6. Labour safety recommendations

3. Working principle of hammering

The impact of the hitting hammer face is transmitted through the workpiece to the strong, inflexible support which is repelling the blow.

The material gets compressed - it cannot yield in the direction of the blow.

It yields to two or more sides, depending on the shape of the hitting hammer head and on the shape of the hammering support, with such shapes getting impressed into the surface of the workpiece.

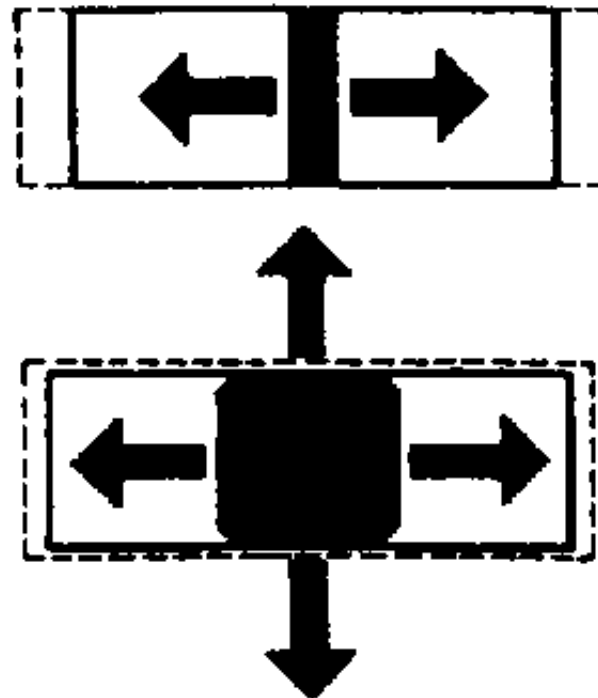

Figure 14 Effect of hammer pane and hammer face

Notes

- Ductile materials can be hammered only - brittle materials cannot be formed by hammering!**
- The more hammer blows, the faster hardening and the harder the material!**
- In case of extensive forming operations the hardness is to be reduced by "annealing" and "cooling down"!**
- Sheet steel is to be cooled down gradually in the air after annealing - sheet copper is to be quenched in cold water immediately after annealing!**

To ensure maximum hitting accuracy, the blow of the hammer should be directed from the wrist joint.

More powerful blows for heavy forming work should be directed from the shoulder joint.

What is the working principle of hammering?

What property must materials have that shall be hammered?

What is the effect of many hammer blows hitting one point of the workpiece?

How can that effect be reduced or eliminated?



[Home](#) > [ar](#).[cn](#).[de](#).[en](#).[es](#).[fr](#).[id](#).[it](#).[ph](#).[po](#).[ru](#).[sw](#)

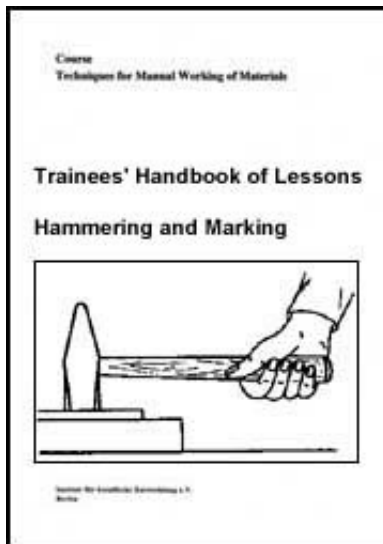

 **Hammering and Marking - Course: Technique for manual working of materials. Trainees' handbook of lessons (Institut fr Berufliche Entwicklung, 17 p.)**

 **(introduction...)**

 **1. Purpose of hammering and marking**

 **2. Tools and accessories**

 **3. Working principle of hammering**

 **4. Working techniques of hammering**

 **5. Working technique of marking**

 **6. Labour safety recommendations**

4. Working techniques of hammering

The effects on the workpiece may be varied by different ways of hammering and selecting appropriate hammering faces.

4.1. Lengthening

Lengthening means elongating or combined elongating and widening of workpieces.

It is mostly applied to sheet metal strips or strip steel.

Principle

When the hammer pane of the engineers' hammer hits the entire width of the metal strip, the material is yielding to the front and rear.

Several successive blows lengthen the material - the strip gets longer.

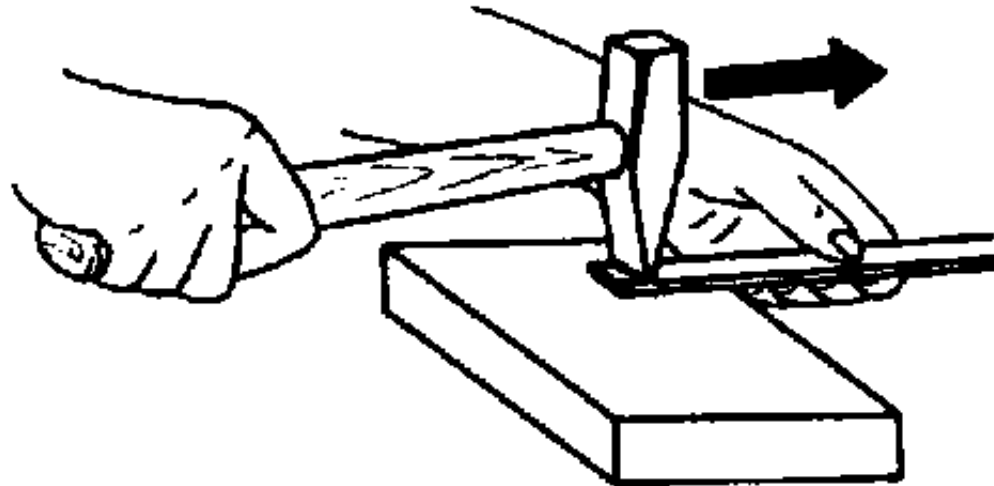

Figure 15 Lengthening with hammer pane

When the hammer face of the engineers' hammer hits the metal strip, the material is yielding to all sides.

Several successive blows lengthen and widen the material - the strip gets longer and wider.

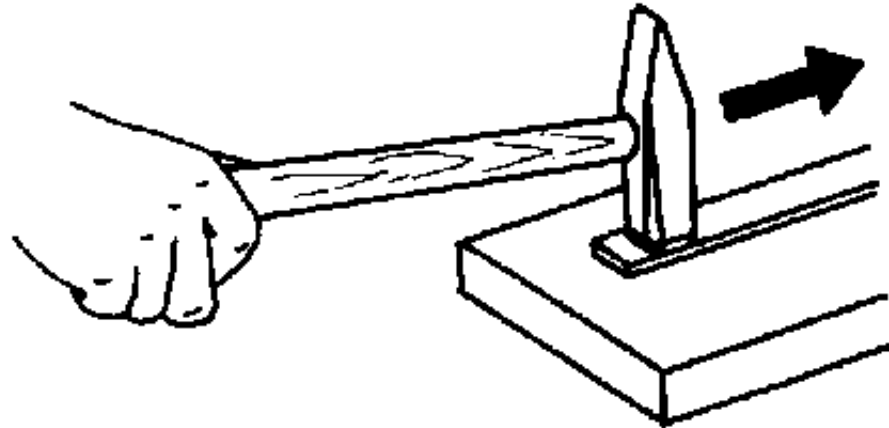

Figure 16 Lengthening and widening with hammer face

Note

The blows must be directed from front to rear or rear to front in rapid succession.

4.2. Curving

Curving means one-sided lengthening of sheet metal strips or strip steel to give a two-dimensional curved shape.

Principle

When the hammer pane of the engineers' hammer or the faces of the curving hammer obliquely hit one side of the strip, the material is yielding into two directions at this side only. Steady successive hammer blows result in one-sided

lengthening of the material, the strip gets longer and curved.

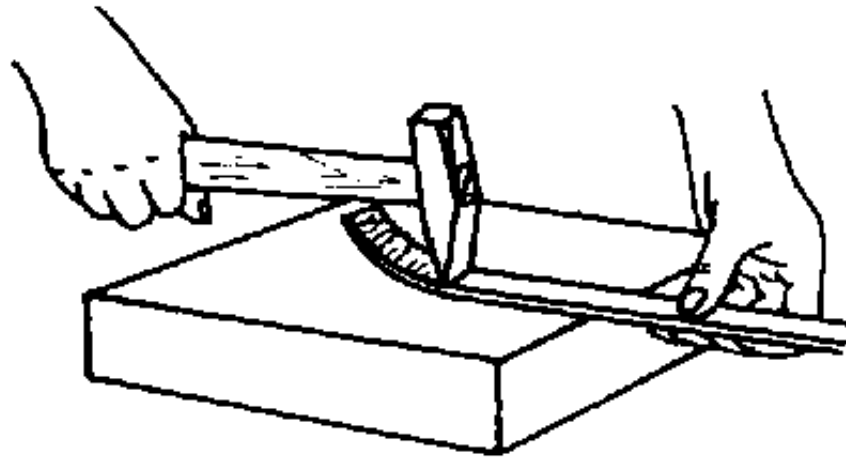

Figure 17 Two-dimensional curving with hammer pane

Note

The blows must be directed as described for lengthening!

4.3. Chasing

Chasing means three-dimensional shaping of thin sheet metal.

Principle

Version 1 - flat hammering support

When the hammer face of the chasing hammer hits a sheet metal disk, the material is yielding circularly to all sides.

Steady hammer blows spirally from the centre of the disk outward cause the

border to curve upward.

The blows in the middle must be closer than outside!

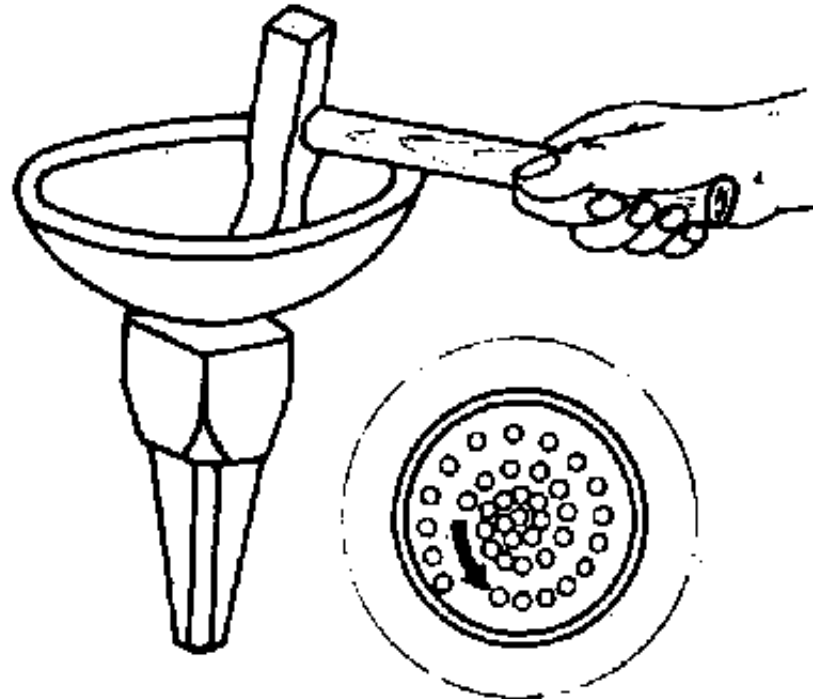

Figure 18 Chasing on flat hammering support

Notes

- **The hammer blows must not reach the border!**
- **The many blows make the metal thinner and harder in the middle - it may easily tear!**
- **Therefore, sheet steel is to be annealed and gradually cooled down!**
- **Therefore, sheet copper is to be annealed and quickly cooled down!**

Version 2 - hollow hammering support

The metal sheet is put on a steel tube with rounded upper edge and held.

Steady hammer blows with a radiused wooden hammer spirally from the border inward cause the sheet metal to curve downward.

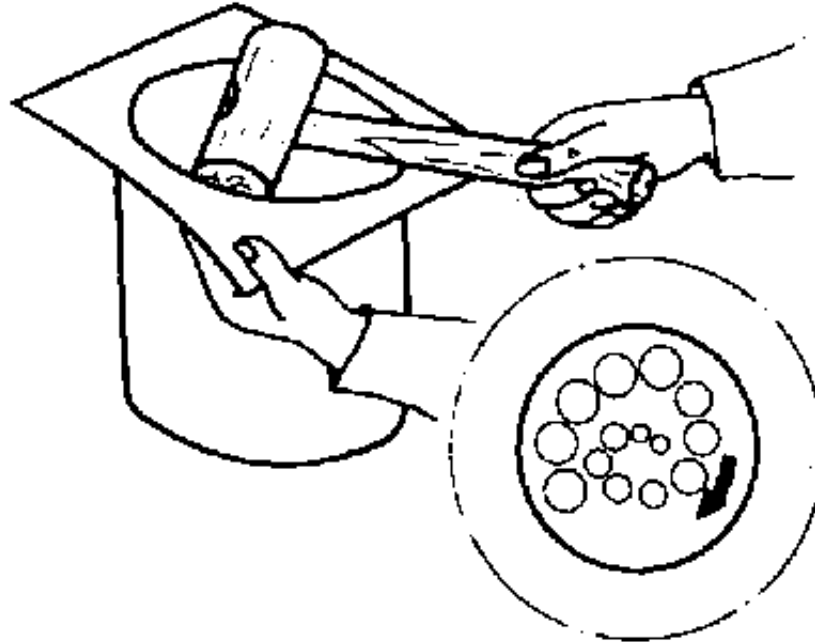

Figure 19 Chasing on hollow hammering support

The hammer blows must reach the centre at the end only!

Notes

- The many hammer blows make the metal thinner and harder - it may easily tear!

- Therefore, sheet metal is to be annealed and adequately cooled down!

What makes the difference between lengthening and curving of a sheet metal strip?

How is the blow to be directed when lengthening and curving?

4.4. Flanging

Flanging means bending down of borders of metal sheets obliquely or perpendicularly to the plane of the sheet. There are two types of flanging: outside flanging and inside flanging.

Principle of outside flanging

- Rough-flanging

The circular sheet is put centrically on a somewhat smaller steel tube. With an engineers' hammer, bevelled wooden hammer or aluminium hammer the border projecting outside is bent down by blows hitting obliquely from outside - the border is loosely touching the outside wall of the tube with puckers.

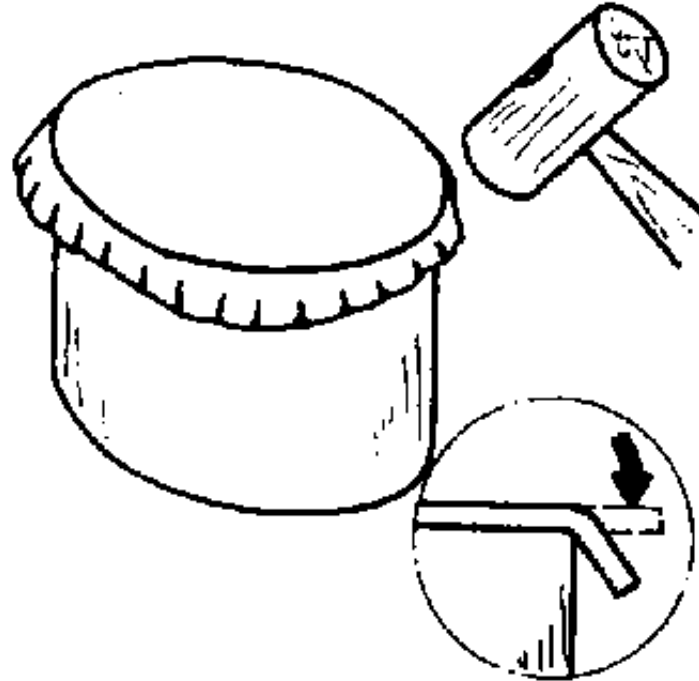

Figure 20 Rough-flanging: bending down of the outside border

Blacksmiths' hardies of various shapes, which have to be clamped in a vice, may also be used as hammering support.

- Finish-flanging:

with the face of the engineers' hammer the puckered border is bulged in on the outside wall of the tube and smoothed.

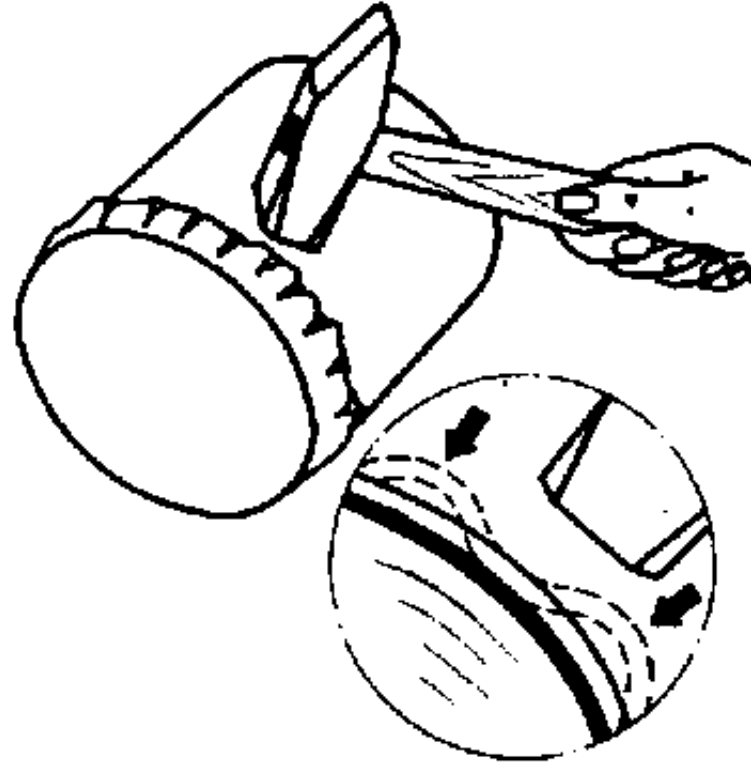

Figure 21 Finish-flanging: bulging in and smoothing of puckers

Principle of inside flanging

- Rough-flanging:

The sheet (1) with the punched hole is inserted in an adequate template (2).

With a bevelled wooden hammer (3).

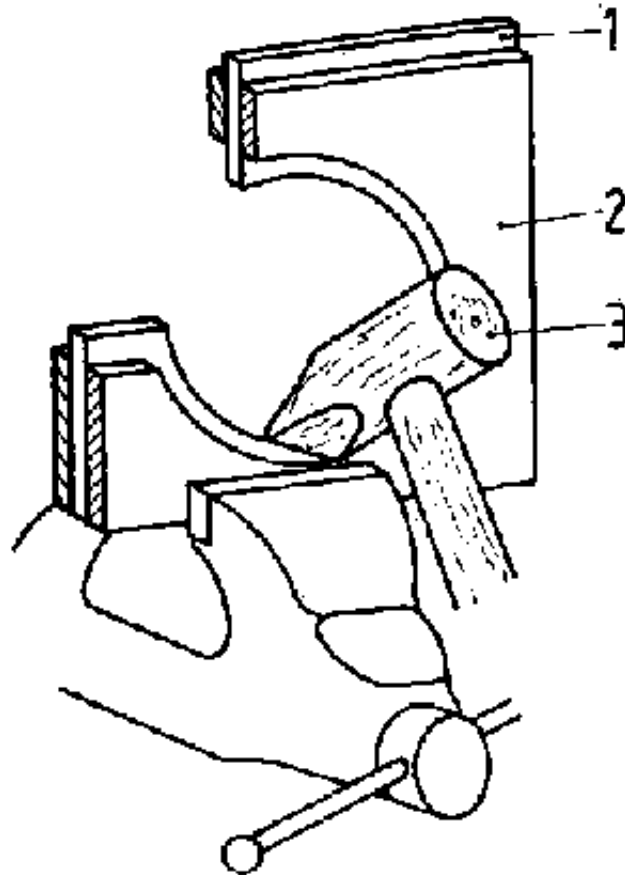

Figure 22 Rough-flanging: bending down of the inside border

a chasing hammer or curving hammer the border projecting inside is bent down with puckers by blows hitting obliquely.

Blacksmiths' hardies of various shapes, the anvil tool or blacksmiths' double face sledges may also be used as hammering support.

- Finish-flanging

With the chasing hammer or curving hammer the puckered border is bulged

in and smoothed.

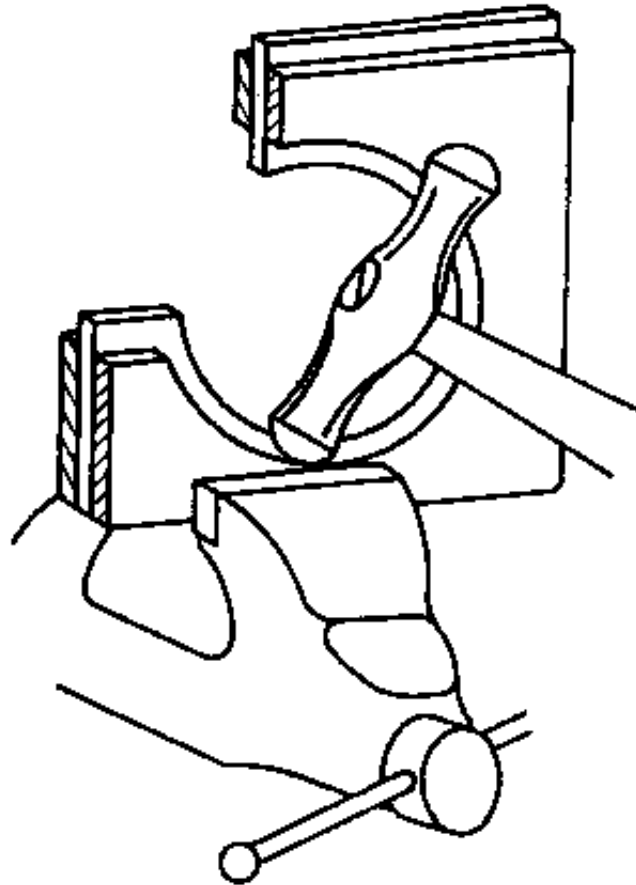

Figure 23 Finish-flanging: bulging in and smoothing of puckers

Notes

- When flanging very large borders, bending is to be performed step by step!

To avoid heavy puckers, a smooth hardwood counterpiece is used for complete bending down of the border!

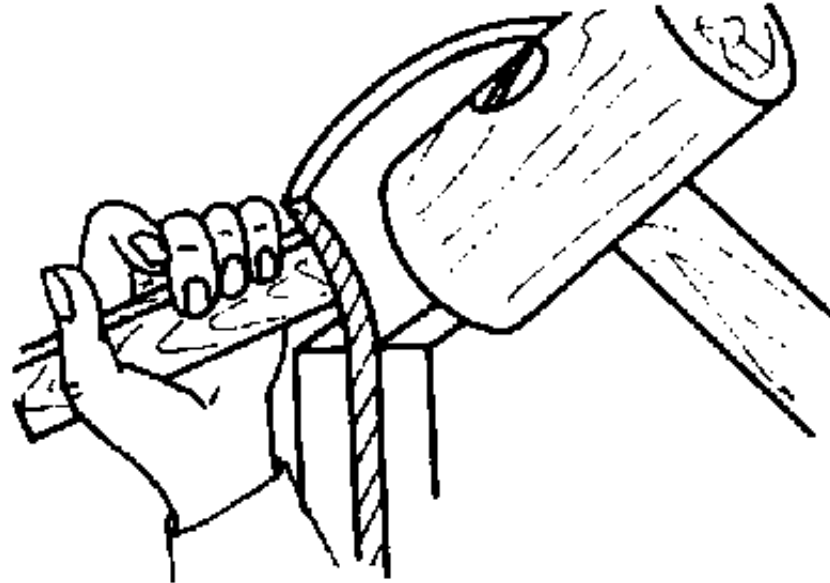

Figure 24 Use of hardwood counterpiece for bending down of large borders

- Sheet metal which is flanged to be used as lids or covering cap of containers should be hammered on the relevant container as hammering support to ensure perfect fit!

Which are the working steps when flanging sheet metal borders?



[Home](#) > [ar](#).[cn](#).[de](#).[en](#).[es](#).[fr](#).[id](#).[it](#).[ph](#).[po](#).[ru](#).[sw](#)

 **Hammering and Marking - Course: Technique for manual working of materials. Trainees' handbook of lessons**

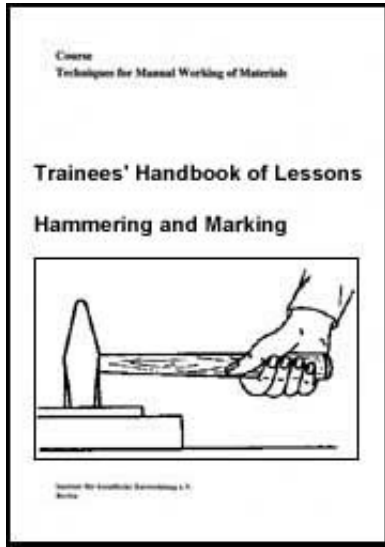

(Institut fr Berufliche Entwicklung, 17 p.)

 **(introduction...)**

 **1. Purpose of hammering and marking**

 **2. Tools and accessories**

 **3. Working principle of hammering**

 **4. Working techniques of hammering**

 **→ 5. Working technique of marking**

 **6. Labour safety recommendations**

5. Working technique of marking

The use of marking punches necessitates exact scribing of the line spacings wherever longer combinations of figures or letters shall be punched.

The following data may serve as guideline for the spacing of the lines (A) in relation to the height of the figures or letters (H):

A	H
3	2.5
5	4
8	6
10	8
12	10

Use a pencil or brass scriber for scribing! After marking remove the scribed line!

The marking punch is applied similar to a centre punch:

The marking punch is set on the scribed line in inclined position, aligned, set vertically and hit by one powerful blow.

Notes

- The direction of the row of figure or letter combinations should be selected so as to permit constant checking of the alignment!

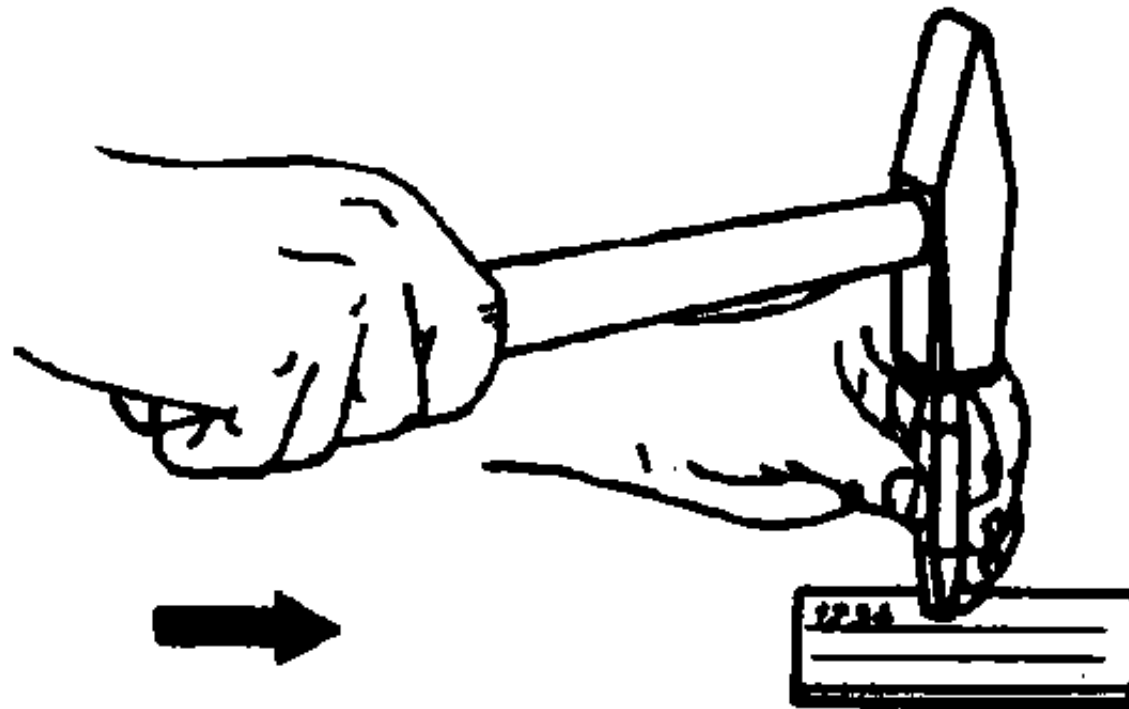

Figure 25 Marking in the direction of blow to the front

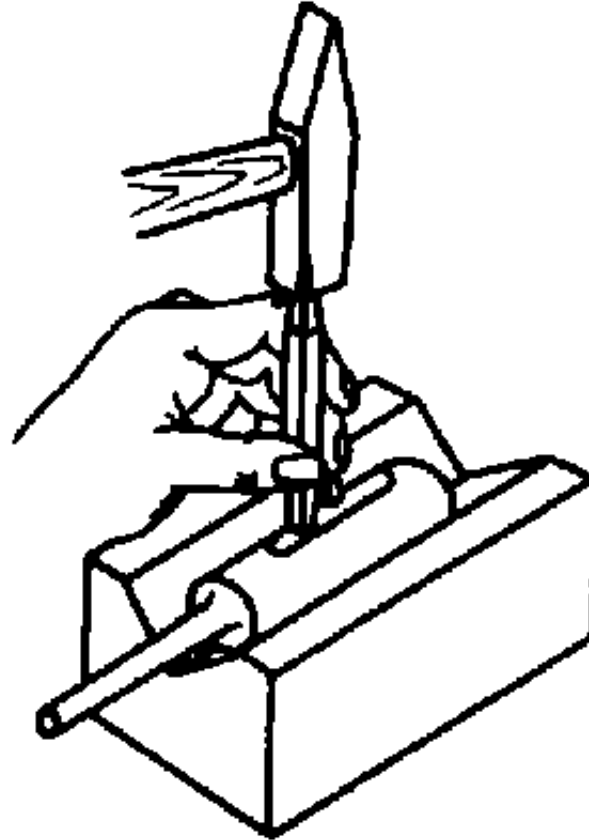

Figure 26 Marking on a filed face of a cylindrical workpiece

- When marking small workpieces a suitable hammering support is to be selected!

Put round stock on a vee!

- If the face to be marked is uneven or not flat, it should be smoothed or flattened'

How is scribing to be done for marking of combinations of figures or letters?



[Home](#) > [ar](#).[cn](#).[de](#).[en](#).[es](#).[fr](#).[id](#).[it](#).[ph](#).[po](#).[ru](#).[sw](#)

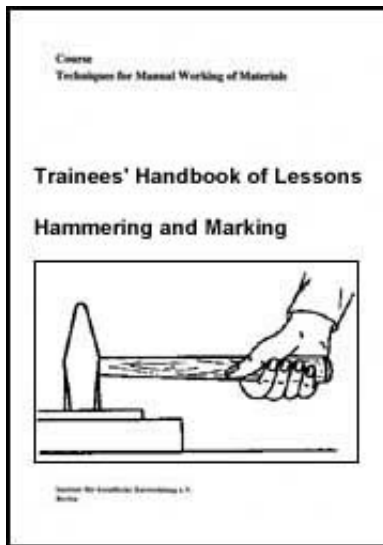

 **Hammering and Marking - Course: Technique for manual working of materials. Trainees' handbook of lessons (Institut für Berufliche Entwicklung, 17 p.)**

 **(introduction...)**

 **1. Purpose of hammering and marking**

 **2. Tools and accessories**

 **3. Working principle of hammering**

 **4. Working techniques of hammering**

 **5. Working technique of marking**

 **➔ 6. Labour safety recommendations**

6. Labour safety recommendations

Use properly fixed hammers only - hammer handle and head must be firmly cottered!

- Select the right hammering support - hard and inflexible surface is required!

- When using any fire for annealing of sheet metal, precautions against fire are to be taken!

