

[Http://cd3wd.com/dvd/10004/](http://cd3wd.com/dvd/10004/) - 2011.09.22

anneal_bend_chip_drill - anneal_bend_chip_drill
anneal_bend_chip_drill - m_annealing_hardening_tempering_gtz077ae
anneal_bend_chip_drill - m_annealing_hardening_tempering_gtz077be
anneal_bend_chip_drill - m_annealing_hardening_tempering_gtz077ce
anneal_bend_chip_drill - m_bearings_slides_h4284b
anneal_bend_chip_drill - m_bending_gtz075ae
anneal_bend_chip_drill - m_bending_gtz075be
anneal_bend_chip_drill - m_bending_gtz075ce
anneal_bend_chip_drill - m_chipping_gtz071ae
anneal_bend_chip_drill - m_chipping_gtz071be
anneal_bend_chip_drill - m_chipping_gtz071ce
anneal_bend_chip_drill - m_drilling_countersinking_gtz068ae
anneal_bend_chip_drill - m_drilling_countersinking_gtz068be
anneal_bend_chip_drill - m_drilling_countersinking_gtz068ce

file_fit_grind_hammer - m_filing_gtz066ae
file_fit_grind_hammer - m_filing_gtz066be
file_fit_grind_hammer - m_filing_gtz066ce
file_fit_grind_hammer - m_fitter_slides_year1_h4276e
file_fit_grind_hammer - m_fitter_slides_year2_h4277e
file_fit_grind_hammer - m_fitting_gtz118ae
file_fit_grind_hammer - m_grinding_gtz073ae
file_fit_grind_hammer - m_grinding_gtz073be
file_fit_grind_hammer - m_grinding_gtz073ce
file_fit_grind_hammer - m_hammering_marking_gtz064ae
file_fit_grind_hammer - m_hammering_marking_gtz064be
file_fit_grind_hammer - m_hammering_marking_gtz064ce

key_knurl_lathe_turn - m_keys_gtz122ae
key_knurl_lathe_turn - m_keys_gtz122be
key_knurl_lathe_turn - m_knurling_gtz103ae
key_knurl_lathe_turn - m_knurling_gtz103be
key_knurl_lathe_turn - m_lathes_gtz097ae
key_knurl_lathe_turn - m_lathes_gtz097be
key_knurl_lathe_turn - m_lathes_gtz100ae
key_knurl_lathe_turn - m_lathes_gtz100be
key_knurl_lathe_turn - m_machinist_slides_year1_h4278e
key_knurl_lathe_turn - m_machinist_slides_year2_h4279e

key_knurl_lathe_turn - m_turner_slides_year1_h4274e
key_knurl_lathe_turn - m_turner_slides_year2_h4275e
key_knurl_lathe_turn - m_turning_slides_h3708e

mill_rivet_scrape - m_milling_gtz104ae
mill_rivet_scrape - m_milling_gtz104be
mill_rivet_scrape - m_milling_gtz107ae
mill_rivet_scrape - m_milling_slides_h3709e
mill_rivet_scrape - m_pinned_joints_gtz119ce
mill_rivet_scrape - m_rivetting_gtz072ae
mill_rivet_scrape - m_rivetting_gtz072be
mill_rivet_scrape - m_rivetting_gtz072ce
mill_rivet_scrape - m_rivetting_slides_8pps_h3706e
mill_rivet_scrape - m_scraping_gtz067ae
mill_rivet_scrape - m_scraping_gtz067be
mill_rivet_scrape - m_scraping_gtz067ce

saw_mark_measure_metalwork - m_manual_sawing_gtz065ae
saw_mark_measure_metalwork - m_manual_sawing_gtz065be
saw_mark_measure_metalwork - m_manual_sawing_gtz065ce
saw_mark_measure_metalwork - m_marking_gtz063ae
saw_mark_measure_metalwork - m_marking_gtz063be
saw_mark_measure_metalwork - m_marking_gtz063ce
saw_mark_measure_metalwork - m_measuring_testing_gtz062ae
saw_mark_measure_metalwork - m_measuring_testing_gtz062be
saw_mark_measure_metalwork - m_measuring_testing_gtz062ce
saw_mark_measure_metalwork - m_metal_working_manual_gtz116e
saw_mark_measure_metalwork - m_metal_working_manual_gtz117e
saw_mark_measure_metalwork - m_metal_working_slides_h4283e
saw_mark_measure_metalwork - m_metalwork_slides_h4240b

shape_shear_straighten - m_shaping_gtz111ae
shape_shear_straighten - m_shaping_gtz111be
shape_shear_straighten - m_shaping_gtz112be
shape_shear_straighten - m_shaping_gtz113ae
shape_shear_straighten - m_shaping_gtz113be
shape_shear_straighten - m_shaping_gtz114be
shape_shear_straighten - m_shaping_slides_h3710e
shape_shear_straighten - m_shearing_gtz074ae
shape_shear_straighten - m_shearing_gtz074be

shape_shear_straighten - m_shearing_gtz074ce
shape_shear_straighten - m_straightening_gtz076ae
shape_shear_straighten - m_straightening_gtz076be
shape_shear_straighten - m_straightening_gtz076ce

thread_ream_weld - m_manual_reaming_gtz069ae
thread_ream_weld - m_manual_reaming_gtz069be
thread_ream_weld - m_manual_reaming_gtz069ce
thread_ream_weld - m_threading_gtz101ae
thread_ream_weld - m_threading_gtz101be
thread_ream_weld - m_threading_gtz120ae
thread_ream_weld - m_threading_gtz120be
thread_ream_weld - m_threading_gtz120ce
thread_ream_weld - m_threading_manual_gtz070ae
thread_ream_weld - m_threading_manual_gtz070be
thread_ream_weld - m_threading_manual_gtz070ce
thread_ream_weld - m_welder_slides_h4273e
thread_ream_weld - m_welding_h3564e
thread_ream_weld - m_welding_h3587e
thread_ream_weld - m_welding_h3588e
thread_ream_weld - m_welding_h3589e

**Keyed Joints – Course: Techniques of Fitting and Assembling
Component Parts to Produce Simple Units. Instruction Examples for
Practical Vocational Training**

Table of Contents

<u>Keyed Joints – Course: Techniques of Fitting and Assembling Component Parts to Produce Simple Units. Instruction Examples for Practical Vocational Training</u>	1
<u>Preliminary Remarks</u>	1
<u>Instruction Example 35.1. Tapered Driving Key Joints</u>	1
<u>Instruction Example 35.2. Laid-in Key Joint</u>	4
<u>Instruction Example 35.3. Tangential Key Joint</u>	7
<u>Instruction Example 35.4. Cotter Joint</u>	10

Keyed Joints – Course: Techniques of Fitting and Assembling Component Parts to Produce Simple Units. Instruction Examples for Practical Vocational Training

**Institut für berufliche Entwicklung e.V.
Berlin**

Original title:
Lehrbeispiele für die berufspraktische Ausbildung
“Keilverbindungen”

Author: Frank Wenghöfer

First edition © **IBE**

Institut für berufliche Entwicklung e.V.
Parkstraße 23
13187 Berlin

Order No.: 90–33–3135/2

Preliminary Remarks

The present material gives 4 selected instruction examples, by which the making of different types of keyed joints can be practised.

In these examples, drive-fitted keys, sunk keys, tangential keys and cotters are used.

Since keyed joints are made in various ways according to the respective function of the machine parts, simple pieces for exercise were chosen for practising the assembly and disassembly of the connections.

The material for the exercises must be prepared mechanically by turning, milling, shaping and reaming. In doing so, the given fitting sizes must be observed.

The keys are taken from standardized ranges or are to be premanufactured according to the given dimensions.

The prefabrication of the starting material is not described in this material.

In order to facilitate the preparation and carrying out of the exercises, the required materials, tools, devices, measuring and testing means as well as auxiliary accessories are indicated for each instruction example. Furthermore, the previous knowledge required for the accomplishment of the exercises is mentioned.

With the help of the working drawings and the appertaining sequences of operations the exercises can be independently be done by the trainees.

Instruction Example 35.1. Tapered Driving Key Joints

Practising the making of a keyed joint using a drive-fitted key.

Material

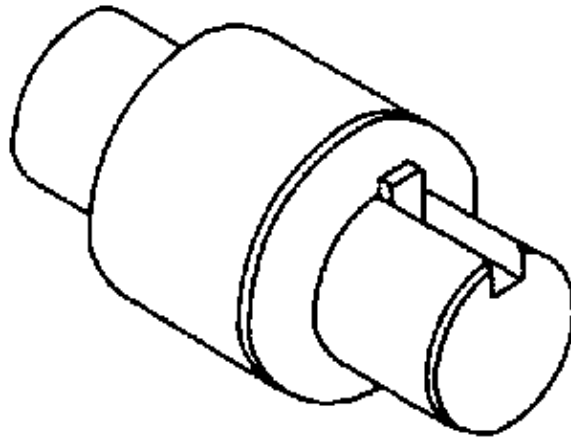

Component parts of steel (420 MPa) premanufactured according to the working drawing:

- Shaft (1)
 - Diameter 50 h 6
 - Length: 150 mm approx.
- Hub (2)
 - Diameter: 70 mm
 - Length: 65 mm
- Drive-fitted key (3)
 - Height: 8.7 mm
 - Width: 14 h 9
 - Length: 70 mm

Tools

Finishing file 200 mm (half-round), triangular scraper, locksmith’s hammer, hand hacksaw.

Measuring and testing means

Vernier caliper, plug limit gauge \varnothing 50 H 7, external limit gauge \varnothing 50 h 6, dial gauge with tripod and holding device for shaft.

Auxiliary accessories

Vice with soft-metal protective jaws, machine grease, cotter driver.

Necessary previous knowledge

Measuring, testing, fundamentals of fitting.

Sequence of operations

Comments

1. Preparing the workplace.
Making the working material available.

Checking for completeness.

2. Checking the individual parts for accuracy of size and burr; deburring, if necessary.	<ul style="list-style-type: none"> – Shaft (1) – Hub (2) – Drive-fitted key (3)
3. Putting the key in the keyways of the assembled parts by way of trial.	Finding out the bearing contact pattern on the back surface, reworking the surfaces to fit.
4. Sawing the tapered driving key to final length (approximately 63 mm).	Tapered driving key must not project from the side of the hub.
5. Greasing the shaft and the hub slightly and reassembling them.	
6. Putting in a slightly greased tapered driving key and fixing it with the help of hammer and cotter driver.	Clamp the component parts firmly in the vice!
7. Testing the joint.	<ul style="list-style-type: none"> – Firm fit of the hub. – Exact fitting of the tapered driving key. – True running.
8. Undoing the joint, dismantling of hub and shaft.	Driving out the tapered driving key in opposite direction by cotter driver.

14h9	0 -0,043
14D10	+0,120 +0,050
50h6	0 -0,016
50H7	+0,025 0

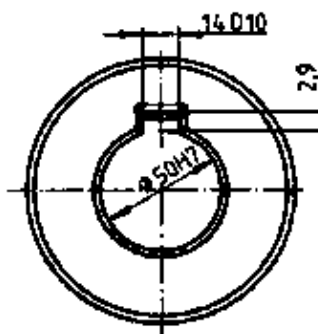
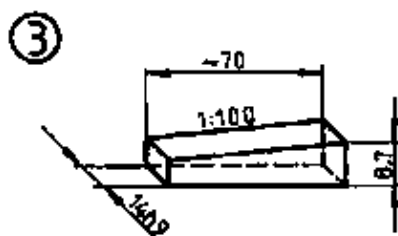
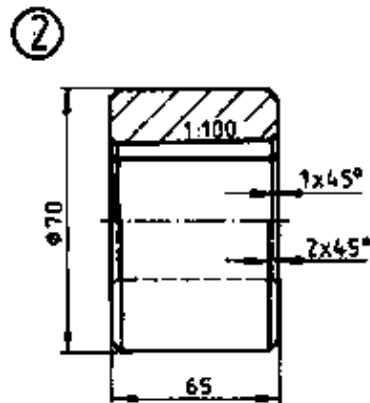
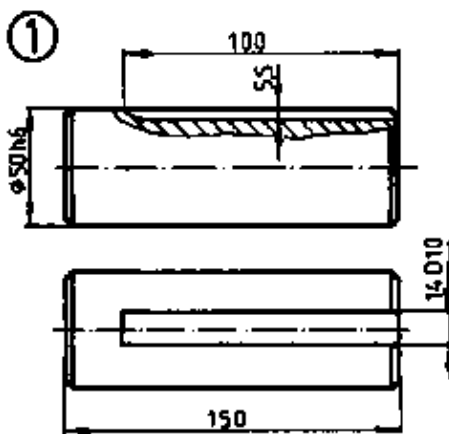
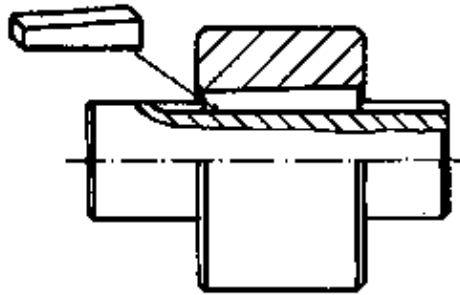

			35.1.
IBE	Tapered Driving		3135

Instruction Example 35.2. Laid-in Key Joint

Making a keyed joint by using a laid-in key.

Material

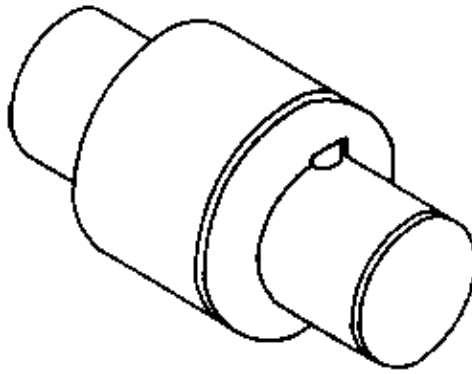

Individual parts of 420 MPa steel premanufactured according to the working drawing:

- Shaft (1)
 - Diameter: 50 h 6
 - Length: 150 mm, approx.
- Hub (2)
 - Diameter: 70 mm
 - Length: 65 mm
- Sunk key (3)
 - Height: 8.7 mm
 - Width: 14 h 9
 - Length: 63 mm

Tools

Finishing file 200 mm, half-round; triangular scraper, hand screw press with hollow die and support.

Measuring and testing means

Vernier caliper, plug limit gauge $\varnothing 50 H 7$, external limit gauge $\varnothing 50 h 6$, dial gauge with tripod and holding device for shaft.

Auxiliary accessories

Vice with soft-metal protective jaws, machine grease.

Necessary previous knowledge

Measuring, testing, fundamentals of fitting.

Sequence of operations

Comments

1. Preparing the workplace.
Making the working materials available.

Checking for completeness.

2. Checking the individual parts for accuracy of size and bun; deburring, if necessary.

– Shaft (1)
– Hub (2)
– Laid-in key (3)

- | | |
|---|--|
| 3. Pitting the laid-in key in the hub keyway. | Key must be easy to put in. |
| 4. Putting together (on trial) of shaft and hub over the key. | Finding out the bearing contact pattern of the back surface, reworking the surface to fit. |
| 5. Greasing shaft and hub slightly and putting them together again. | Pressing the elements together by using hand screw press. |
| 6. Testing the connection. | <ul style="list-style-type: none">- Firm fit of hub- True running |
| 7. Dismantling of hub and shaft, taking the laid-in key out. | Forcing the elements apart by means of hand screw press. |

14h9	0 -0,043
14D10	+0,120 +0,050
50h6	0 -0,016
50H7	+0,025 0

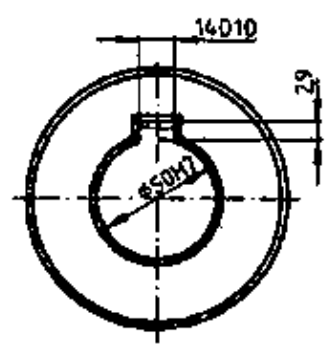
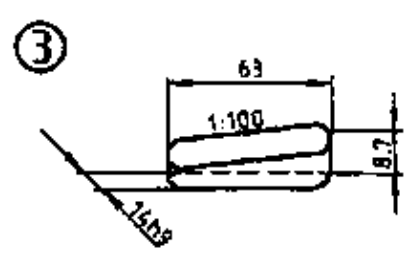
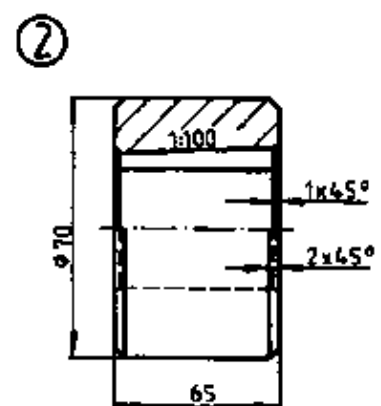
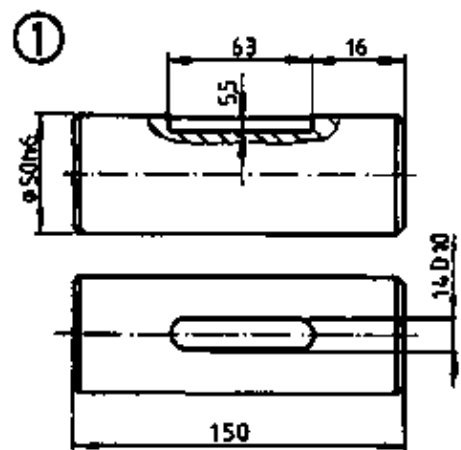
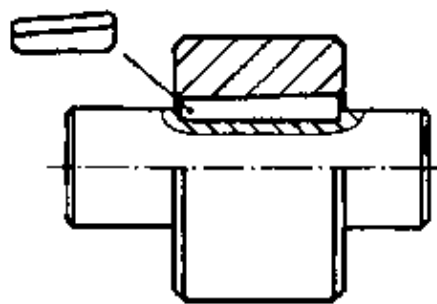

				35.2.
IBE	Laid-in Key Joint			3135

Instruction Example 35.3. Tangential Key Joint

Making a keyed joint by using tangential keys.

Material

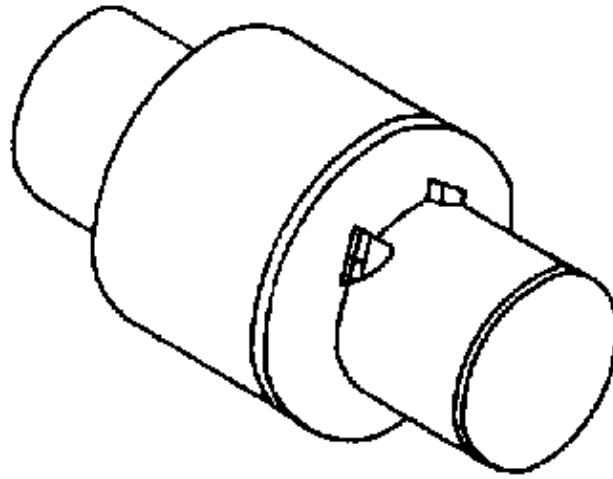

Steel parts from 420 MPa steel, premanufactured according to working drawing:

- Shaft (1)
 - Diameter: 50 h 6
 - Length: 150 mm
- Hub (2)
 - Diameter 70 mm
 - Length: 75 mm
- 2 pairs of tangential keys (3)
 - Height: 6 mm
 - Width: 9 mm
 - Length: 90 mm

Tools

Finishing file 200 mm, half-round; triangular scraper, hand hacksaw, locksmith's and light-metal hammers.

Measuring and testing means

Vernier caliper, plug limit gauge \varnothing 50 h 7, external limit gauge \varnothing 50 h 6, dial gauge with tripod and holding device for shaft.

Auxiliary accessories

Vice with soft-metal protective jaws, machine grease, cotter driver or non-ferrous metal arbor.

Necessary previous knowledge

Measuring, testing, fundamentals of fitting.

Sequence of operations

Comments

1. Preparing the workplace.
Making the working material available.

Checking for completeness.

- | | |
|---|--|
| 2. Checking the individual parts for accuracy of size and bun; deburring, if necessary. | <ul style="list-style-type: none"> – Shaft (1) – Hub (2) – 2 pairs of tangential keys (3) |
| 3. Putting the keys in the keyways of the assembled parts (on trial); putting one key in each keyway first, then driving in the other keys alternately. | Finding out the bearing contact pattern of the back surfaces and reworking them to fit. |
| 4. Sawing the keys to their final length – approximately 80 mm | Keys are allowed to project from the hub laterally by maximally 2 mm. |
| 5. Slightly greasing shaft and hub separately and putting them together again. | |
| 6. Putting in the slightly greased tangential keys and fixing them alternately with hammer and cotter driver. | Clamp the component parts firmly in the vice! |
| 7. Testing the joint. | <ul style="list-style-type: none"> – Firm fit of the hub – Accurate fit of the tangential keys – True running |
| 8. Undoing the connection, disassembling of hub and shaft. | Driving out the keys with cotter driver. |

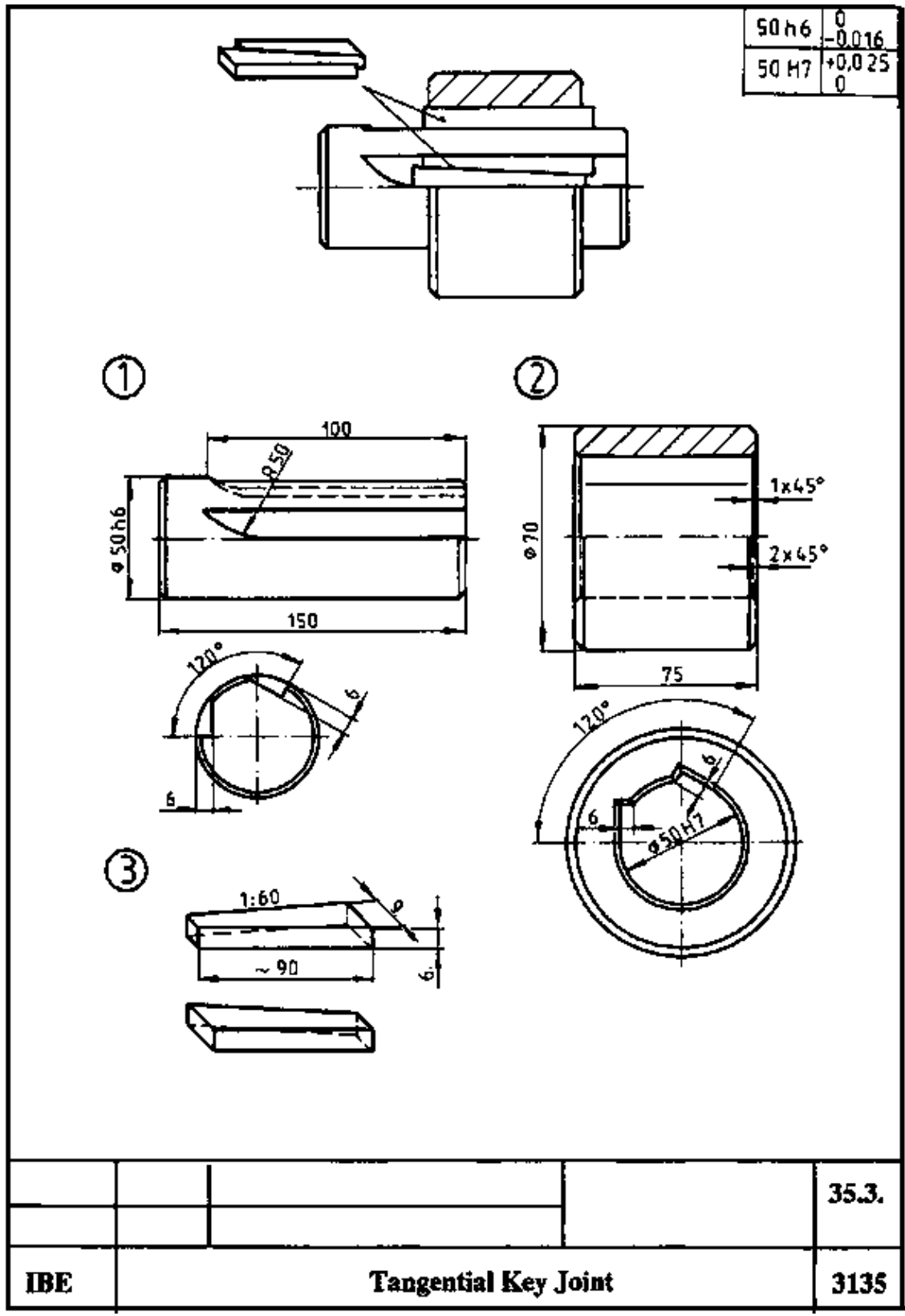

Instruction Example 35.4. Cotter Joint

Making a keyed joint by using a cotter.

Material

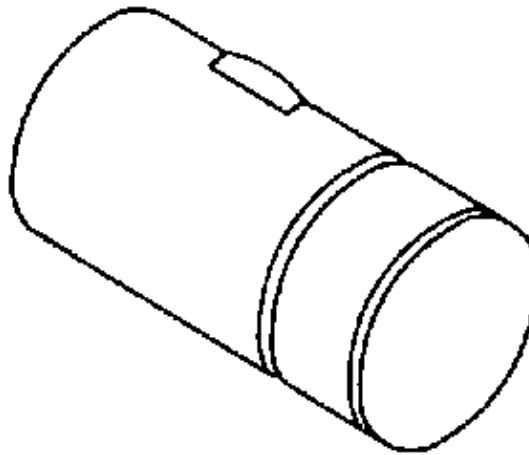

Premanufactured 420 MPa steel parts, premanufactured according to the working drawing:

- Sleeve (1)
 - Diameter: 50 mm
 - Length: 150 mm
- Core (2)
 - Diameter: 50 mm
 - Length: 110 mm
- Cotter (3)
 - Height: 20.5 mm
 - Width: 6 mm
 - Length: 60 mm

Tools

Finishing file 200 mm, half-round; triangular scraper; locksmith's and light-metal hammers; hand hacksaw

Measuring and testing means

Vernier caliper

Auxiliary accessories

Vice with soft-metal protective jaws, machine grease, non ferrous metal arbor

Necessary previous knowledge

Measuring, testing, fundamentals of fitting

<u>Sequence of operations</u>	<u>Comments</u>
1. Preparing the workplace Making the working material available.	Checking of completeness.
2. Checking the individual parts for accuracy of size and burr; deburring, if necessary.	– Sleeve (1) – Core (2) – Cotter (3)

3. Putting the key in the oblong hole of the aligned and assembled parts (on trial).

Finding out the bearing contact pattern, reworking the surface to fit.

4. Sawing the cotter to its final length and chamfering its head by filing.

5. Putting the slightly greased cotter in the oblong hole and fixing it by hammer blows.

Using light-metal hammer for fixing.

6. Testing the connection.

- Firm fit of sleeve and core
- Firm fit of the cotter
- Even flush of the cotter
- head-ends may project

7. Undoing the connection; dismantling of sleeve and core.

Driving the cotter out with non-ferrous metal arbor.

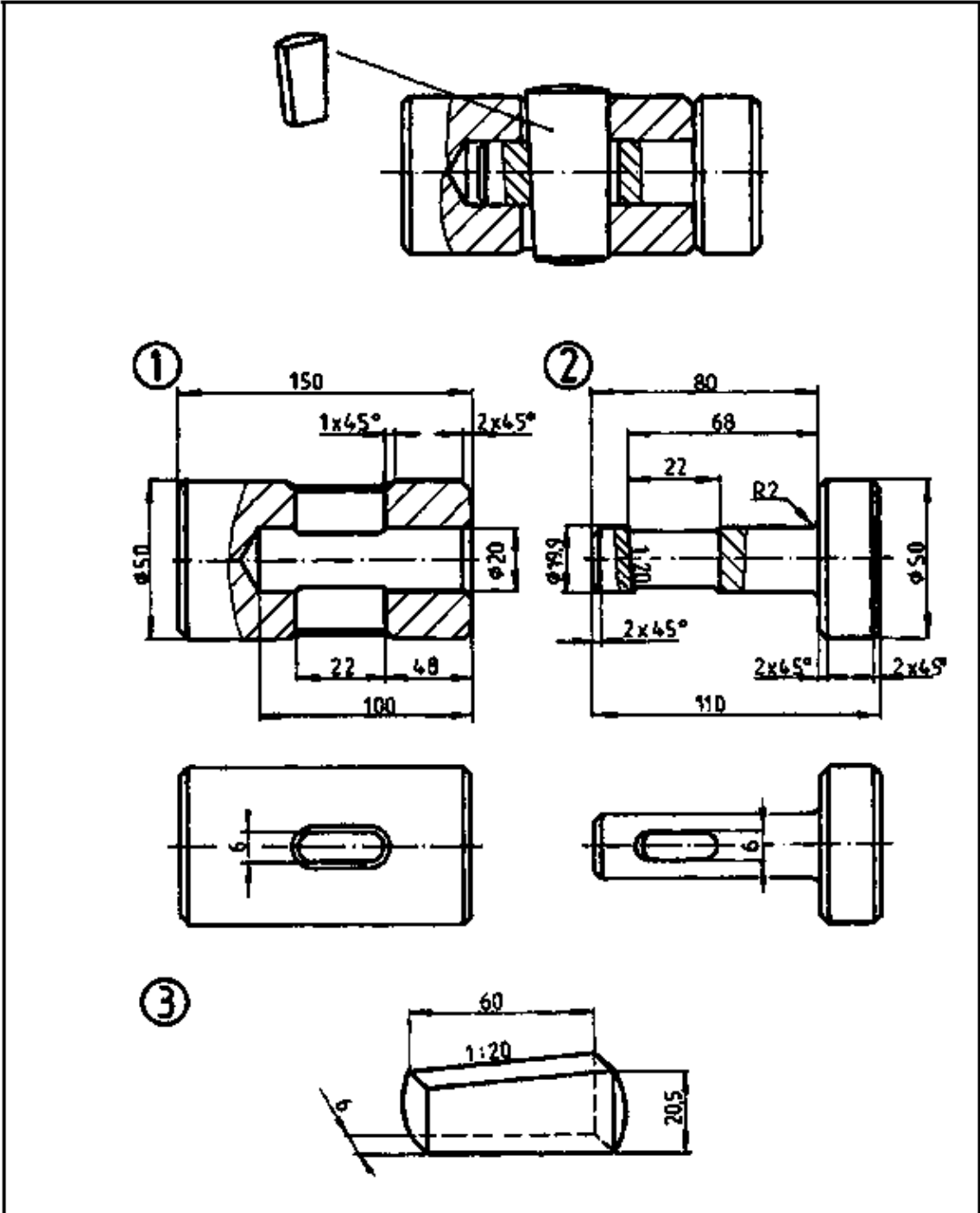

			35.4.
IBE	Cotter Joint		3135

**Keyed Joints – Course: Techniques of Fitting and Assembling
Component Parts to Produce Simple Units. Trainees' Handbook of
Lessons**

Table of Contents

<u>Keyed Joints – Course: Techniques of Fitting and Assembling Component Parts to Produce Simple Units. Trainees' Handbook of Lessons</u>	1
<u>Preliminary Remarks</u>	1
<u>Hints on Labour Safety</u>	1
<u>1. Intended Use of Keyed Joints</u>	1
<u>2. Types of Keys</u>	2
<u>3. Types of Keyed Joints</u>	7
<u>4. Kinds of Stress Acting on Keyed Joints</u>	8
<u>5. Tools and Auxiliary Accessories</u>	9
<u>6. Selected Technological Operations for Making Keyed Joints</u>	13
<u>7. Undoing of Keyed Joints</u>	23

Keyed Joints – Course: Techniques of Fitting and Assembling Component Parts to Produce Simple Units. Trainees' Handbook of Lessons

**Institut für berufliche Entwicklung e.V.
Berlin**

Original title:
Arbeitsmaterial für den Lernenden
"Keilverbindungen"

Author: Frank Wenghöfer

First edition © **IBE**

Institut für berufliche Entwicklung e.V.
Parkstraße 23
13187 Berlin

Order No.: 90–35–3135/2

Preliminary Remarks

The present material is designed for the training in occupations which – in addition to knowledge in the field of manual and mechanical metal working – require mastership of assembly operations.

The material describes the various ways of joining component parts with the help of keys taking the function of the respective unit into consideration.

The making and undoing of keyed joints are explained by their main steps.

The questions at the end of each sections, are intended to help the trainees check their acquired knowledge.

Hints on Labour Safety

On principle, the regulations on industrial safety apply which have to be observed with the techniques of filing, scraping, reaming, milling and slotting.

Special attention has to be paid to the following focal points:

- Use only clean, undamaged and sharp tools.
- Clamp the workpieces safely and firmly but so that they are not damaged.
- Keep the measuring and testing instruments in a safe place, protect them against damages caused by shock and/or corrosion.
- Keep your workplace in order, keep fittings pieces always together with their matching parts.

1. Intended Use of Keyed Joints

Keyed joints are detachable joints connecting machine parts by fasteners – keys – a non-positive way.

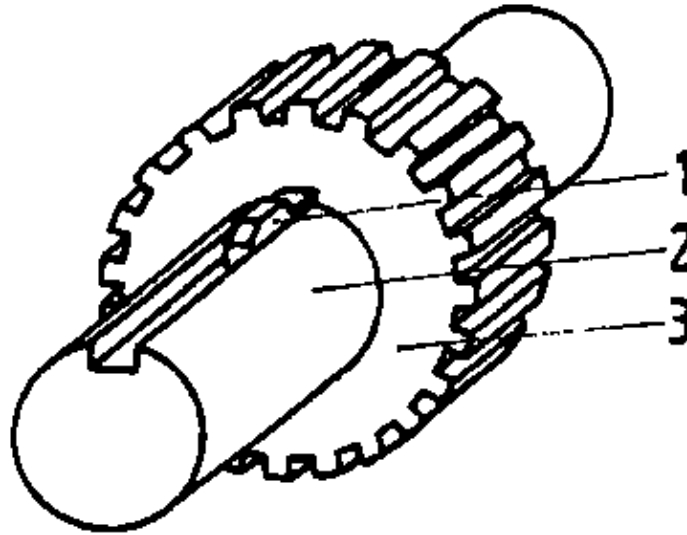

Figure 1 – Keyed Joints

1 key, 2 shaft, 3 hub

Keyed joints are made in order to

- connect machine parts that shall perform rotational movements transmitting little to great rotary powers;
- connect machine parts that shall perform a to-and-fro movement where little to great axial force must be transmitted;
- connect machine parts in such a way that their exact position relative to one another can be adjusted.

If parts of machines are designed as keys or tapers, they can be connected immediately as a result of this shape. In this case, no additional wedges are required. Such machine parts must be adapted to one another very accurately. Advantage of keyed joints:

- Guarantee of function even with reciprocal stress in the form of shocks.

Disadvantage:

- With rotating machine parts, the accuracy of true running is not guaranteed in case of high peripheral speeds.

2. Types of Keys

Keys are made from drawn steel with a tensile strength of approximately 700 MPa. They must have a greater strength and hardness than the machine parts to be connected, so that they are not deformed when they are driven in.

Taper sunk keys

These are long bodies with a rectangular cross-section, inclined back surface and with plane or rounded front surface.

The inclination has the proportion of 1:100, which means: the taper is 1 mm per 100 mm.

- Round-ended sunk keys are called laid-in keys – they are pressed (or inserted) into the snugly fitting groove of the shaft and the hub is subsequently driven on to the sunk key. These keys are used if there is no space for driving the key in or out

– Straight-ended sunk keys, also called tapered driving keys – in this case the shaft and the hub (or the machine parts in question) are mounted as in normal use and the sunk key driven in subsequently.

They are used if there is sufficient space to drive them in and out from either side.

– Tapered driving keys the thicker ends of which feature a nose are called gib-head keys. They are used if driving in or out can be done from one side only.

– Woodruff keys can also assume the function of taper sunk keys because – due to their rotatable mounting in the keyway they are able to adapt themselves to the taper in a hub keyway.

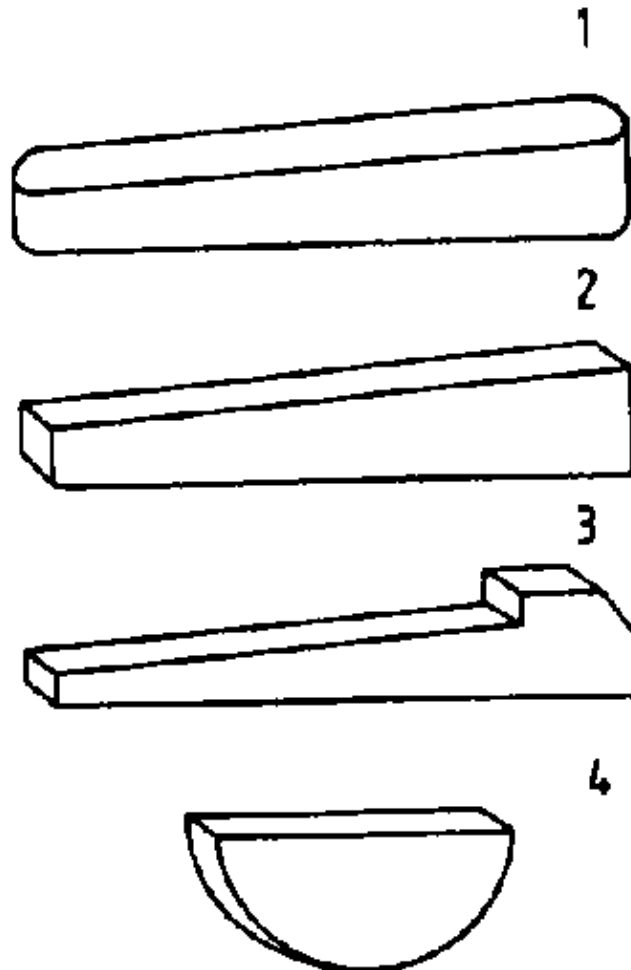

Figure 2 – Taper sunk keys

1 laid-in sunk key, 2 tapered driving key, 3 gib-head key, 4 Woodruff key

Hollow and flat keys

These are long bodies with a rectangular cross-section with inclined back surface and small taper. They are only used for transmitting little rotary forces. For these no keyway must be made:

– The bottom of hollow keys is concave in longitudinal direction. The edges of these keys resemble cutting edges which contact the shaft.

– A good adaption of the flat key to the shaft is achieved only, if the shaft is flattened corresponding to the width of the key in that place where the key shall be applied.

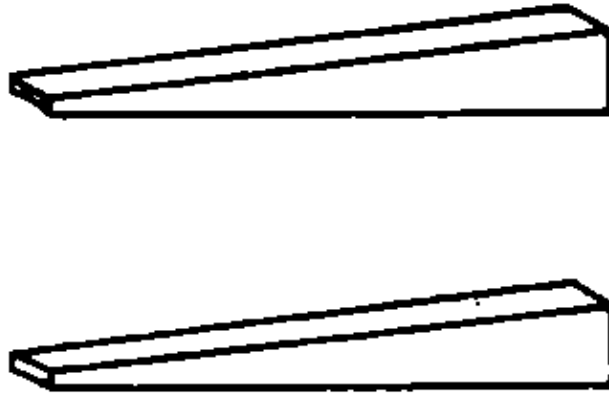

Figure 3 – Hollow and flat keys

Tangential keys

These consist in a pair of mating bodies of a rectangular cross-section. Each of these bodies has one inclined side face, the inclination proportion (taper) is 1:60 up to 1:100. Tangential keys are used if very great rotational forces have to be transmitted in both directions of rotation.

With their inclined surface turned towards each other, they are driven into inclined keyslots and hub keyways. In doing so, always two pairs of keys are staggered around the shaft circumference at an angle of 120°.

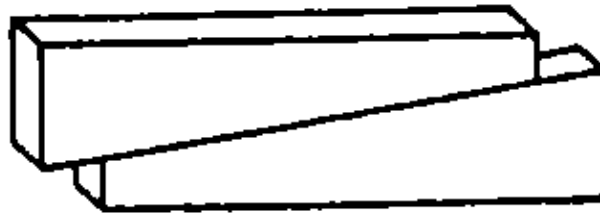

Figure 4 – Tangential keys

Taper sleeves

These are bodies in the form of truncated cones with internal and external tapers serving to connect machine parts directly. In general they are used with machine spindles where tools with taper shanks are applied. For undoing the connection, cotters are driven through lateral oblong holes into the taper sleeves. A special type of taper sleeve is the clamping sleeve, which, as an intermediate, is used in machine part joints. Clamping sleeves are placed on shafts on which then antifriction bearings, toothed gears and similar elements can be mounted. Their uniform circumferential stress which is the result of a taper between 1 in 10 and 1 in 20 guarantees exact true running.

They are fastened by nuts.

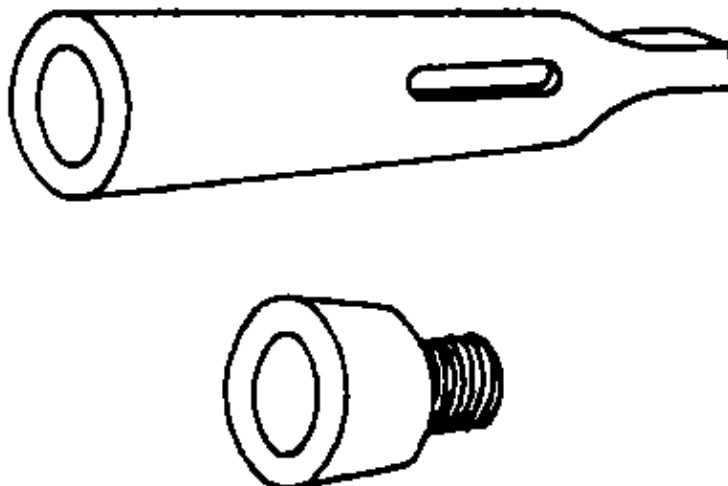

Figure 5 – Taper sleeves and clamping sleeves

Taper pins

These are elongated bodies in the form of truncated cones with a taper of 1 in 50.

In keyed joints they are also called 'cylindrical taper keys'. They are used if a joint shall be made very simply, shall be undone only seldom and has to transmit only little rotational force, for instance levers on axles.

The bore holes are reamed by reamers as it is done with taper pin joints.

For undoing the joint the taper pin must be bored out.

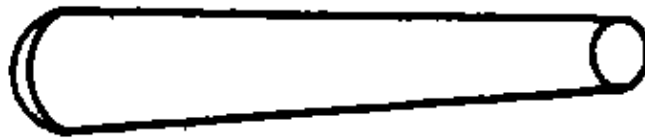

Figure 6 – Taper pin

Cotters

These are rectangular bodies with one or two inclined surfaces the edges of which are rounded.

They are used for fixing bolts and crankshafts in order to transmit longitudinal (to-and-fro) movements.

Cotters have a taper of 1 in 10 up to 1 in 40 and are often secured against loosening by additional means.

Since the manufacturing of the slots requires much time and labour, they are used only, if great axial forces have to be transmitted.

For the transmission of little force, taper pins can be used instead, because this facilitates the making of the joint.

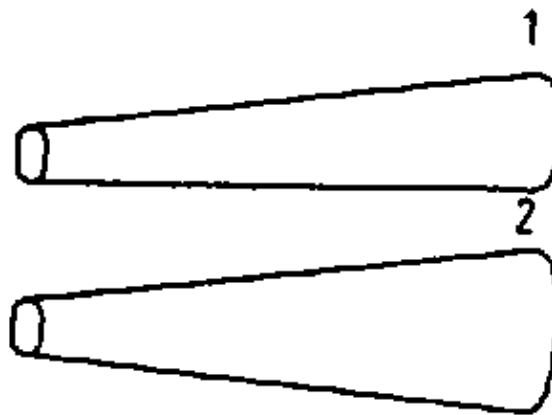

Figure 7 – Cotter

1 with one inclined surface
2 with two inclined surfaces

Tightening keys

These are rectangular bodies with one or two inclined surfaces and a tapped through hole in longitudinal direction.

Tightening keys transmit no rotary forces; they are used for clearance adjustment in divided bearings and guideways. They are applied across the rod axis. In order to achieve a great tightening effect by a short path of positioning in longitudinal direction, the back surfaces are manufactured with a taper between 1: 5 and 1:10.

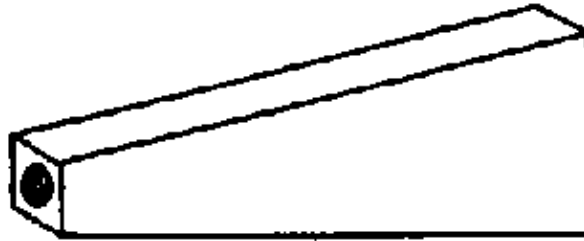

Figure 8 – Tightening key

What are keyed joints?

What is the special advantage of keyed joints?

What disadvantage has to be considered with keyed joints at rotating machine parts?

Which types of keys are used for joining machine parts that have to carry out rotating movements?

What are the tasks cotters have to fulfill?

What are the tasks of tightening keys?

Hints on manufacturing keys

- One's own keys are made only, if no industrially prefabricated ones are available. Keys are manually worked by filing and scraping.
- Since the bottom and back surfaces require reworking when the key is fitted in, they are made with an allowance of 0.3 to 0.5 mm.
- Often, the length of the key can be exactly determined only when the connection is just being made. Therefore, a sufficiently long key should be prepared.
- The side faces of taper sunk keys get the h 9 fit, so that they have enough play in the groove.

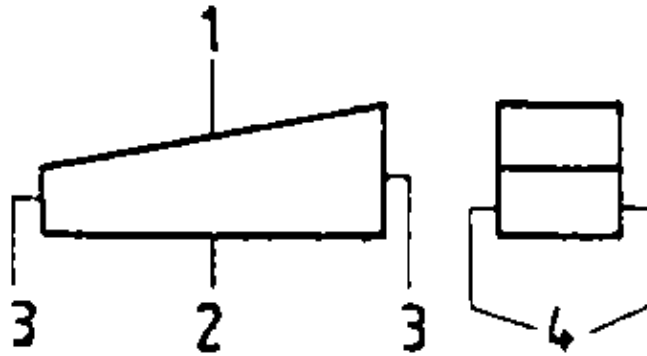

Figure 9 – Surfaces of a key

1 top of key, 2 key bottom, 3 front surfaces, 4 side faces

Sequence of operations for making a key for a shaft–and–hub joint:

- Putting the hub on the shaft
- Determining the key heights according to the dimensions of the grooves (reckoning the taper over again)
- Marking the material for the wedge
- Rough–finishing the taper by filing, breaking the comers $0.5 \times 45^\circ$
- Fitting the key, finding out the drag marks or the bearing contact pattern, scribing the length of the key
- Finishing the surfaces
- Sawing the key to length, breaking the comers, deburring

What allowances have to be made when manufacturing a wedge oneself?

3. Types of Keyed Joints

According to the task of the joint it is distinguished between fastening and tightening key joints. Keys used in fastening key joints are distinguished by their position to the longitudinal axis of the machine parts to be connected. Therefore, they are divided into keys and cotters.

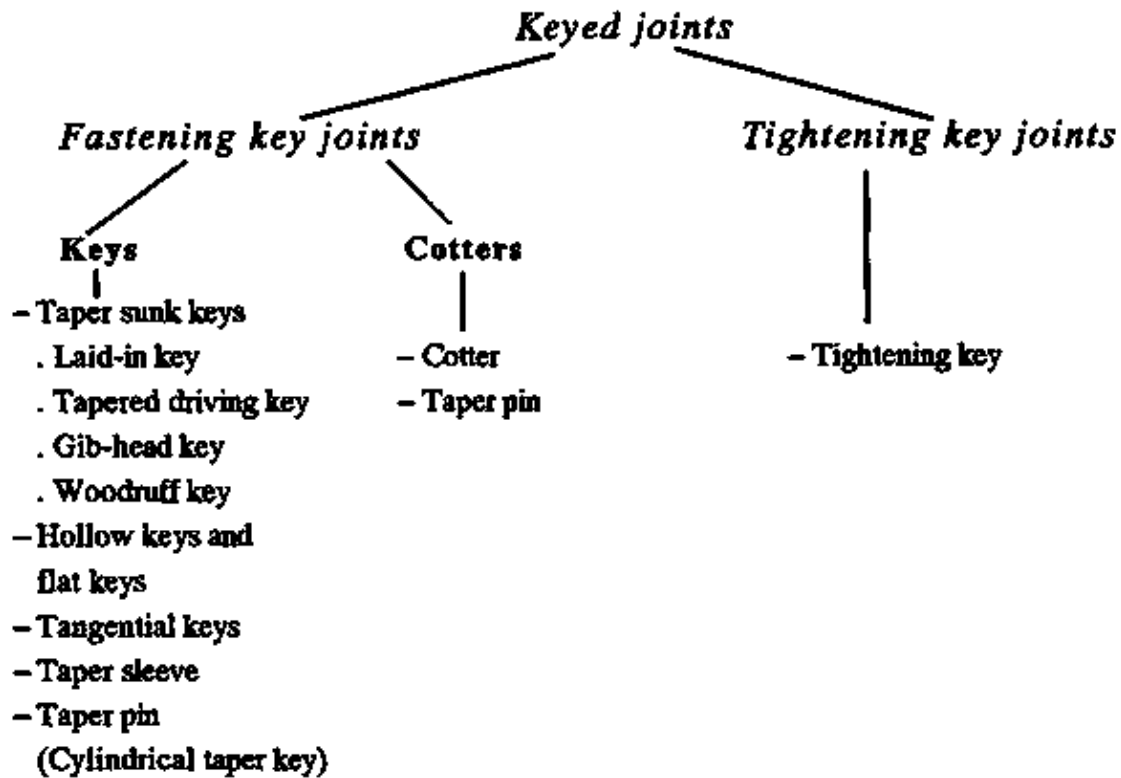

4. Kinds of Stress Acting on Keyed Joints

Keyed joints are non-positive connections – the back surface of the key is pressed against one part of a machine, its bottom surface against the other part of the machine. By this, the two machine parts are tightened with each other.

The tightening strength depends on the pressing-in force, on the angle of inclination of the surfaces and on the friction between the tightened surfaces.

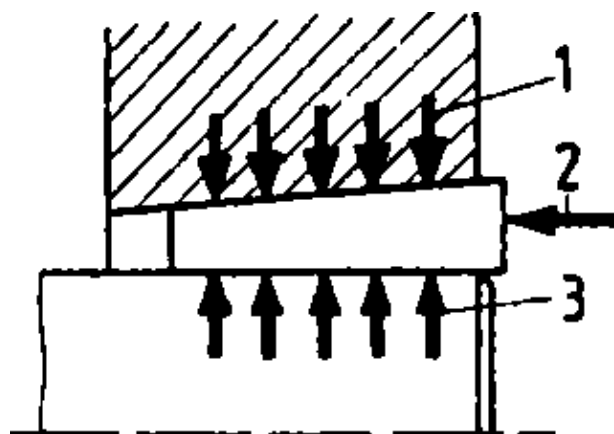

Figure 10 – Stress acting on keyed joints

1 tension between key and hub, 2 pressing-in force, 3 tension between key and shaft

Tightening becomes strong, if the pressing-in force is great. The smaller the taper of the key used, the greater the tightening effect. If there is much friction between the surface to be tightened, a great pressing-in force must be applied.

Principle of action of the keyed joint

The effect of keyed joints is based on the principle of the inclined plane.

It is known that heavy loads can be pulled up on an inclined plane with little force. Especially little force is required, if the plane has a narrow angle of inclination.

This means that keys of a small taper have a great tightening effect, although only little pressing-in force is required.

Therefore, it has to be considered with shaft and hub connections that too strong pressing into place of the key—may destroy the hub or, at least, may disturb the true running. Since, in this type of connection, only the back and bottom surfaces of the key are exposed to pressure, the side faces are normally free of pressure; they have play. However, with too strong rotary forces, the side faces of the wedge get in contact with the groove in shaft and hub.

Then, a shearing stress is generated in the cross section of the wedge on the level of the shaft diameter. As a result of this, the key might shear off.

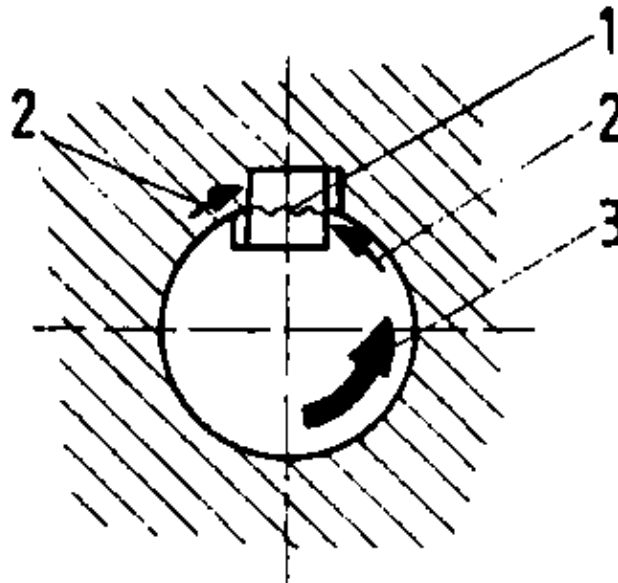

Figure 11 – Stress acting on a keyed joint in case of overload

1 shearing stress, 2 acting forces, 3 rotary force

What types of keyed joints are distinguished?

What stress is the key in the keyed joint exposed to?

5. Tools and Auxiliary Accessories

Shank cutter and cylindrical cutter

Shank cutters are used for making round-end grooves in shafts for laid-in keys as well as for drilling oblong holes for cotters.

Cylindrical cutters are used for making long, shallowing out grooves in shafts for receiving tapered driving keys as well as for making circular grooves for Woodruff keys.

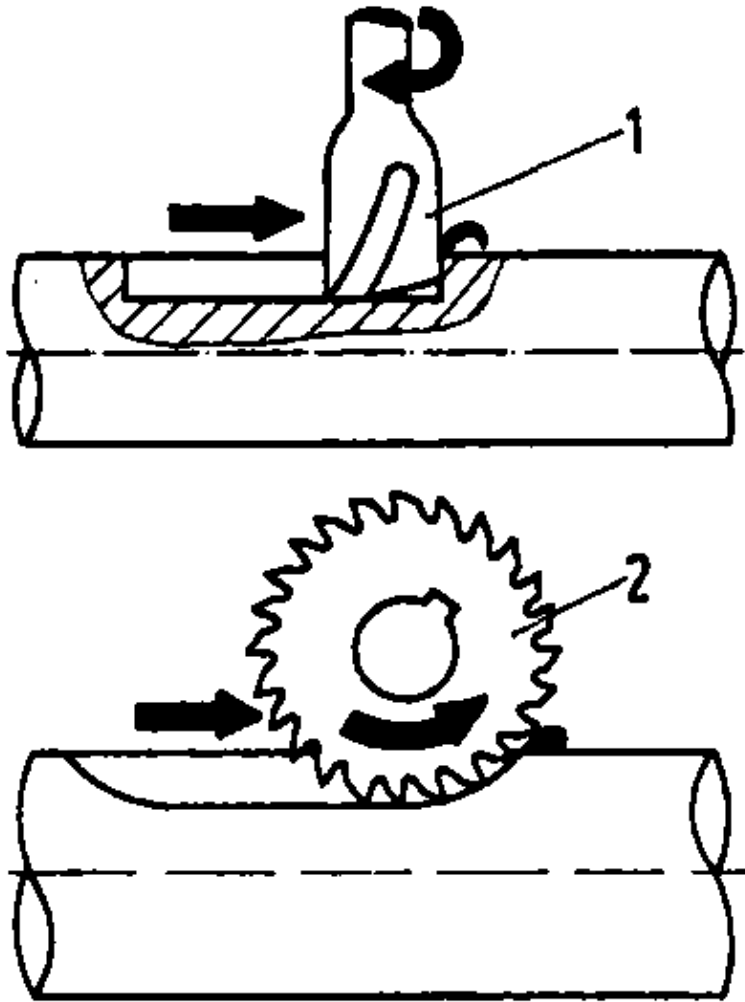

Figure 12 – Making of shaft keyways with the help of

1 end mill cutter, 2 cylindrical cutter

Broaches and grooving tools

Broaches or grooving planer tools are used for making hub key-ways on the respective machines according to the required technique of “broaching” or “shaping”.

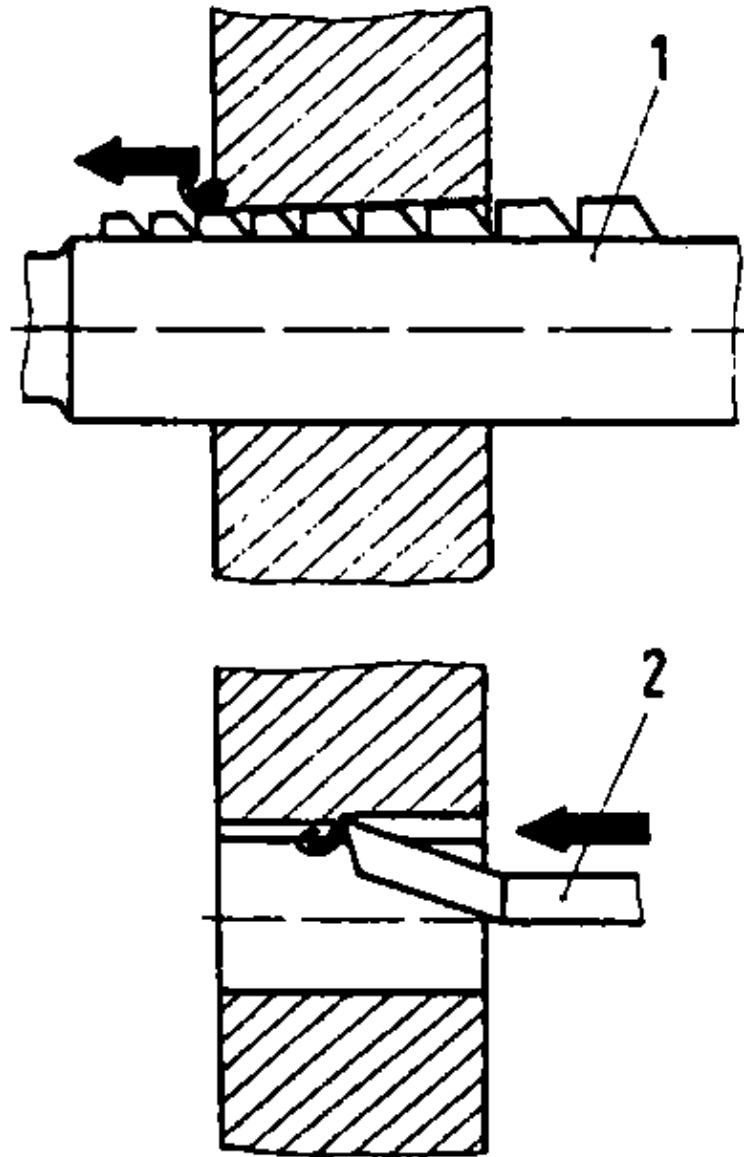

Figure 13 – Making of hub keyways with the help of

1 end mill cutter, 2 cylindrical cutter

Lathe tools and taper reamers

Lathe tools are used for making external tapers with taper sleeves and clamping sleeves. Taper reamers are used for making internal tapers with taper sleeves and taper pin joints.

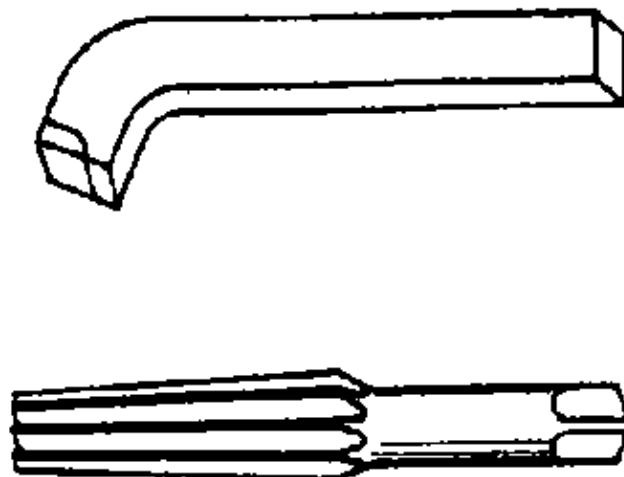

Figure 14 – Lathe tool and taper reamer

Files and scrapers

Finishing files as well as triangular flat scrapers are used for deburring grooves and keys as well as for reworking and fitting of the keys in the grooves.

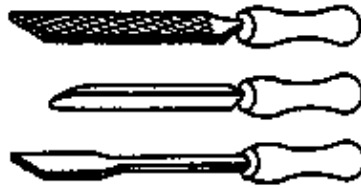

Figure 15 – Files and scrapers

Hammers

Locksmith's hammers are used for pressing the keys in the machine parts and light-metal hammers for pressing in cotters and taper pins.

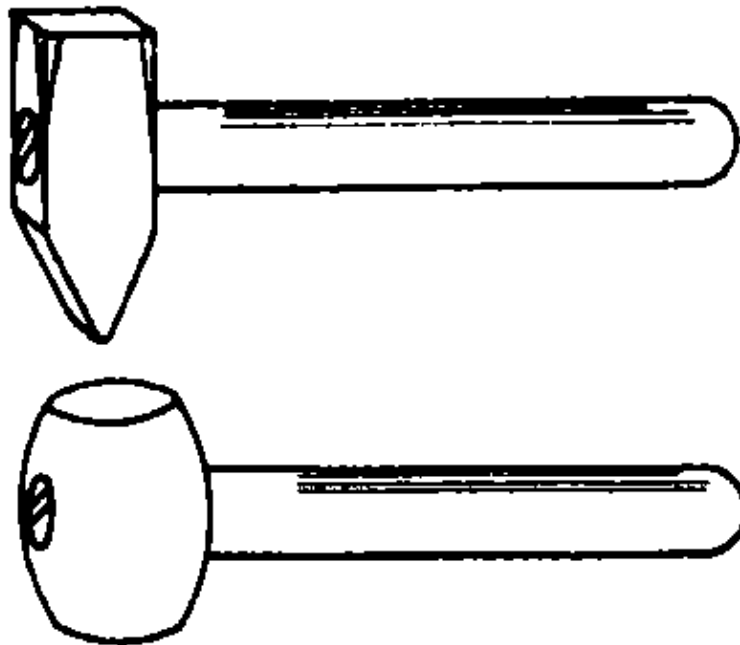

Figure 16 – Hammers

Cotter drivers and key extractors

Cotter drivers are used for forcing in and loosening of keys/cotters with the help of locksmith's hammers.

Non-ferrous metal arbors drifts serve the same purpose.

Key extractors are cotters which are used especially for drawing gib-head keys out of the joint

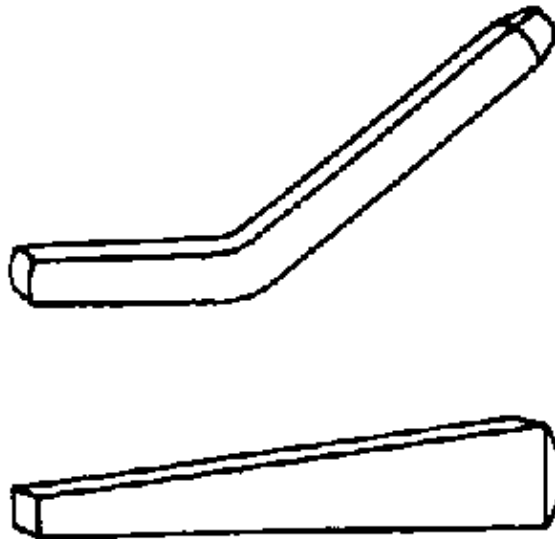

Figure 17 – Cotter driver and cotter extractor

Pullers

Pullers are used for pulling the hub from the shaft, if these parts cohere to each other very firmly and must be loosened.

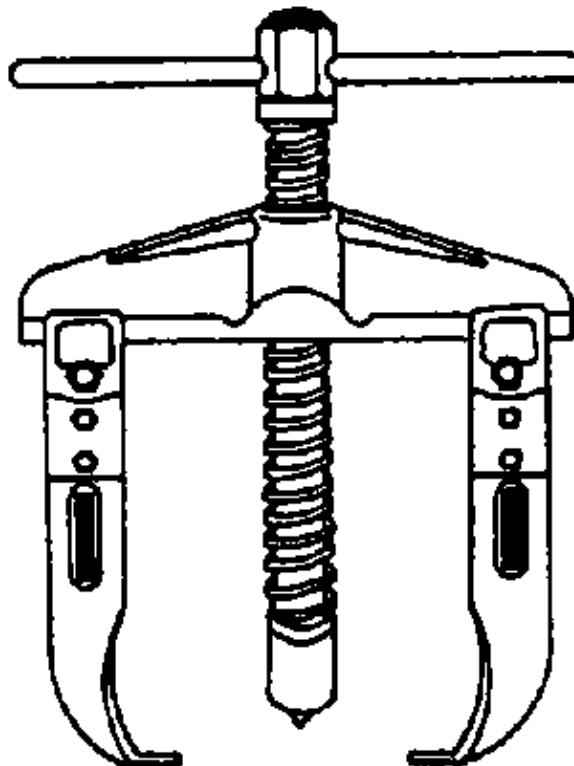

Figure 18 – Pulling device

6. Selected Technological Operations for Making Keyed Joints

The sequence of operations for making keyed joints are different according to the respective type of key that shall be put in.

6.1. Taper Sunk Key Joints

Prefabrication of the slots

If keyed joints shall be made with the help of taper sunk keys, grooves must be prepared in the parts to be joined, in order to receive the key. These parts are machined by “milling”, “broaching” and “shaping”. Mostly, the grooves are given the D 10 fit and must have the taper of 1 in 100 in the hub.

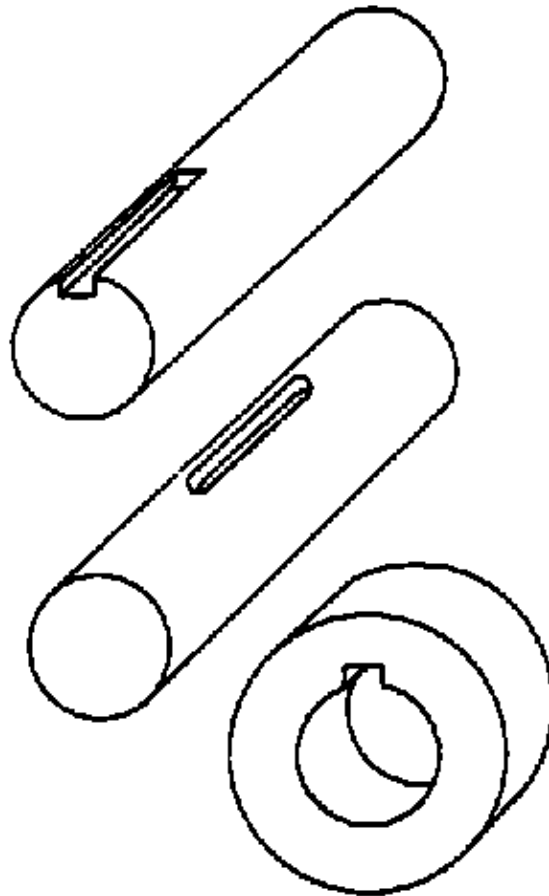

Figure 19 – Individual parts with prepared grooves

Testing the individual parts

The external condition and accuracy to size of the hub and shaft have to be checked. In doing so, make sure that

- the shaft has a clean surface quality without embossments;
- the bore of the hub is free of shoulders or ridges;
- length, width, depth and alignment of the shaft keyway as well as the taper of the hub keyway (1:100) are true to size;
- the accuracy of fit of shaft and hub have been exactly observed (check by external limit gauge or plug limit gauge).

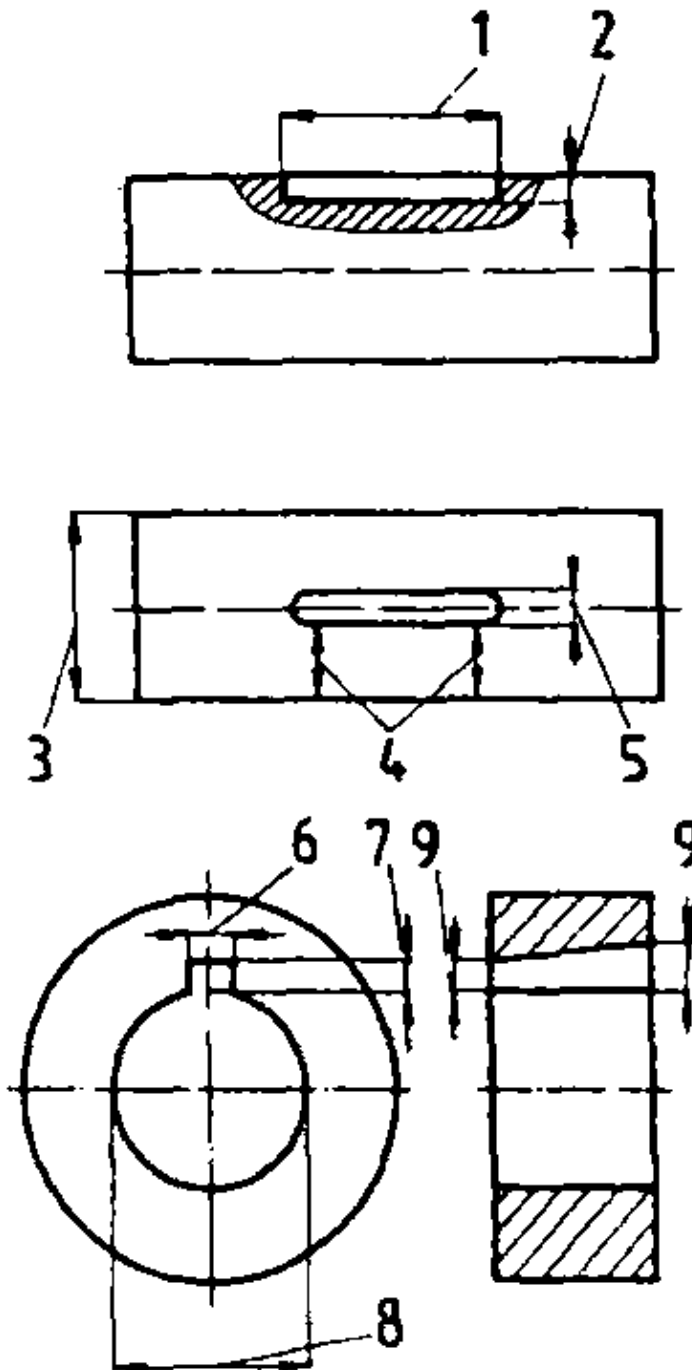

Figure 20 – Checking of the individual parts

1 length of shaft keyway, 2 depth of shaft keyway, 3 fit of shaft, 4 alignment of shaft keyway, 5 width of shaft keyway, 6 width of hub keyway, 7 depth of hub keyway, 8 fit of hub, 9 inclination taper of hub keyway

The clearance between shaft and hub must be kept very small, otherwise the hub moves off the centre by as much as the size of play and cants when the wedge is pressed in.

With high rotational speeds it may therefore come to great balance errors. In order to prevent this it is recommended to joint shaft and hub by a slight interference fit.

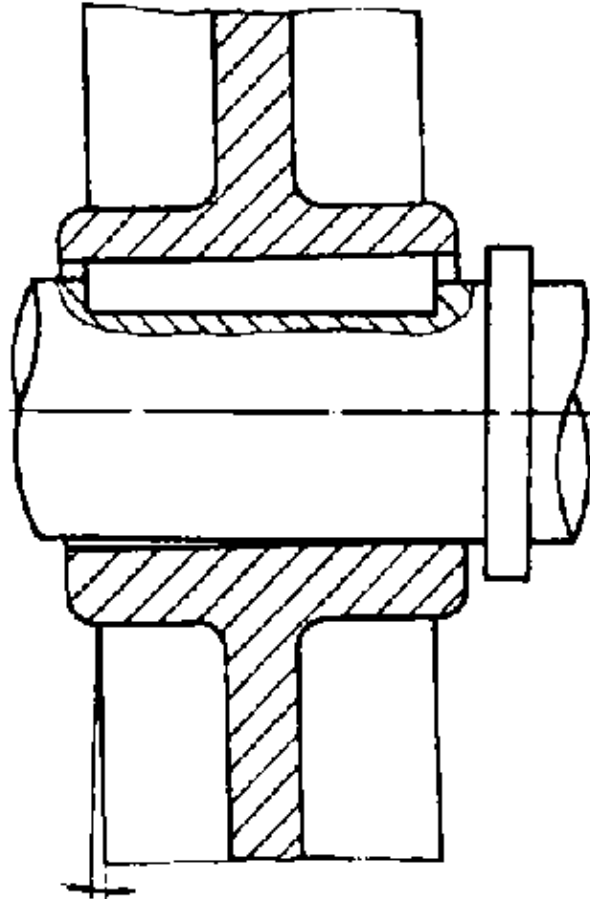

Figure 21 – Canting of hub and shaft due to too much play

Deburring of the individual parts

The keys as well as the keyways in shaft and hub are checked for burrs. Deburring is done by using a file or triangular scraper.

Fitting the key in the keyways

By slight driving-in of the tapered driving key in the keyway of the joined machine parts by way of trial it is found out whether the back surface carries well. For this purpose, one searches for drag marks or rubs the back surface with chalk; in order to find out the bearing contact pattern. Reworking is done by filling or scraping.

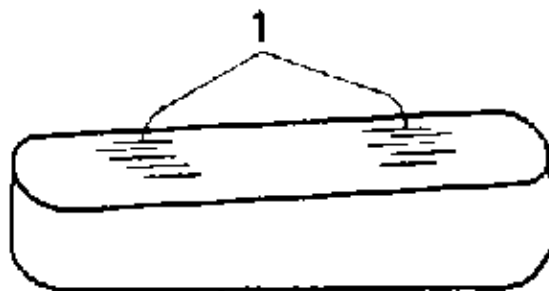

Figure 22 – Bearing contact pattern

1 surface areas required reworking

A similar procedure is followed with laid-in keys. As distinguished from the tapered driving key, the laid-in key is inserted into the shaft keyway and then the hub is driven on to the key.

Hints on the length of tapered driving keys

- After the test fitting, the respective key is sawn to the required length, so that it does not project from the hub.
- The length of gib-head keys is fixed in such a way that after the wedge is driven in the nose projects from the hub by the measure of the key width.

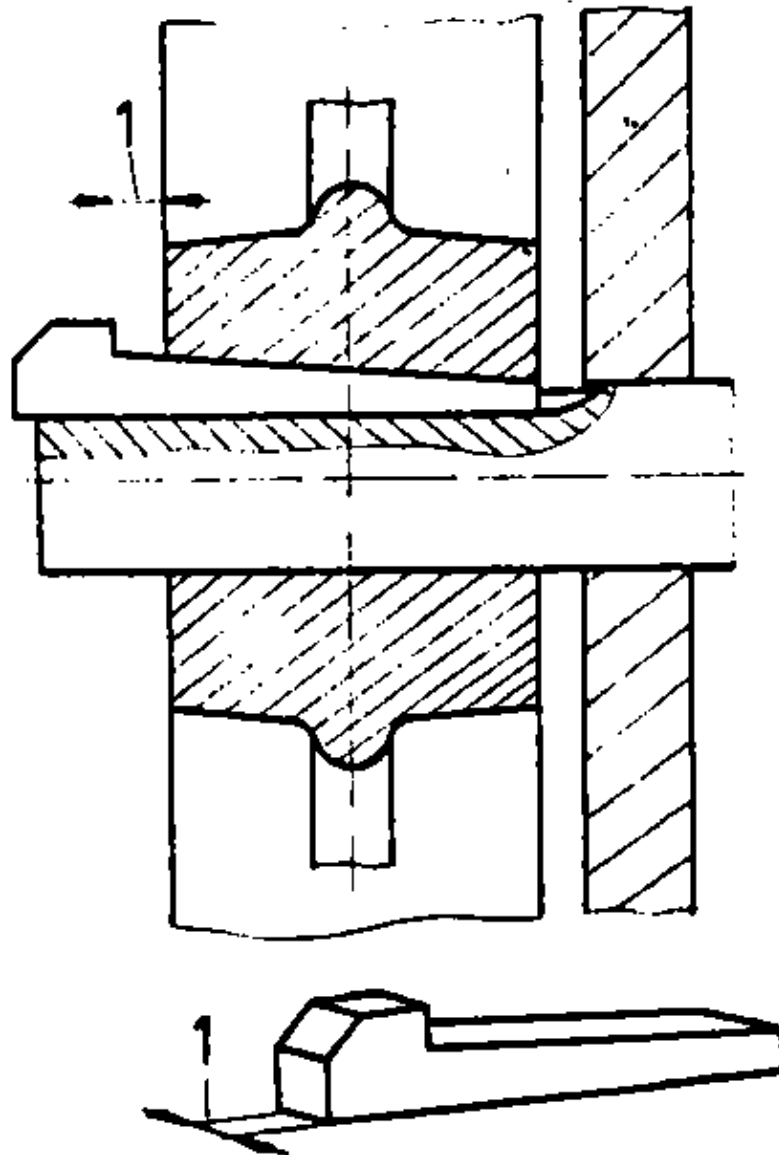

Figure 23 – Gib-head key put in place

1 width of gib-head key

Projecting gib-head keys must be protected by suitable protective caps. Freely rotating machine parts with gib-head keys may easily be the cause of an accident.

Assembling the individual parts

The shaft journal, the hub bore and the key are slightly greased.

Laid-in keys and Woodruff keys are put in the shaft keyway; then the hub is driven on to the shaft by press.

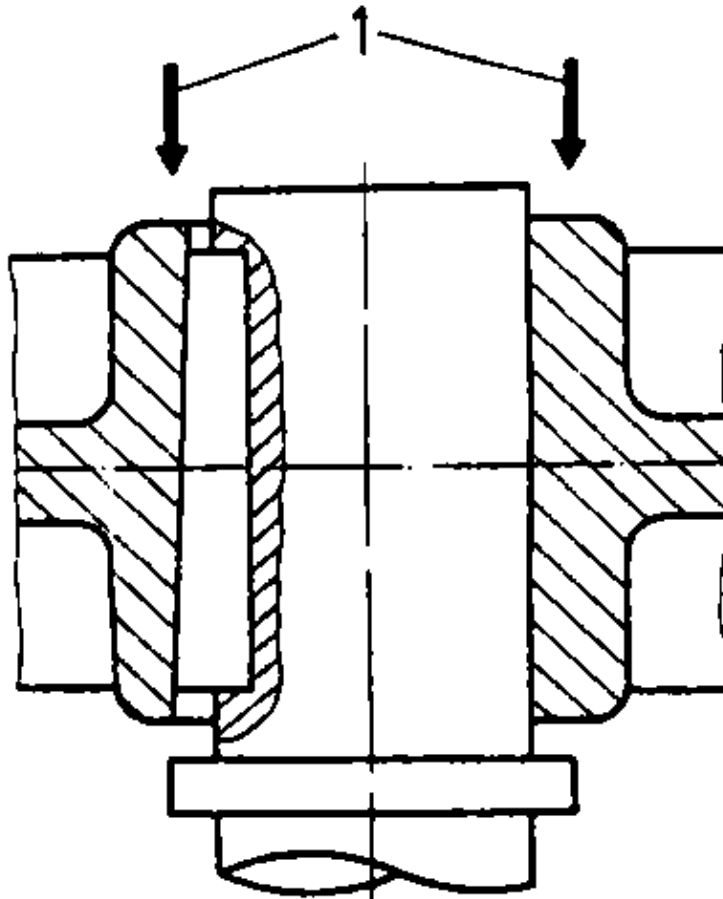

Figure 24 – Pressing-in of the hub using laid-in keys

1 pressing-in force

Tapered driving keys are driven into the previously joined individual parts with the help of a locksmith's hammer and a cotter driver.

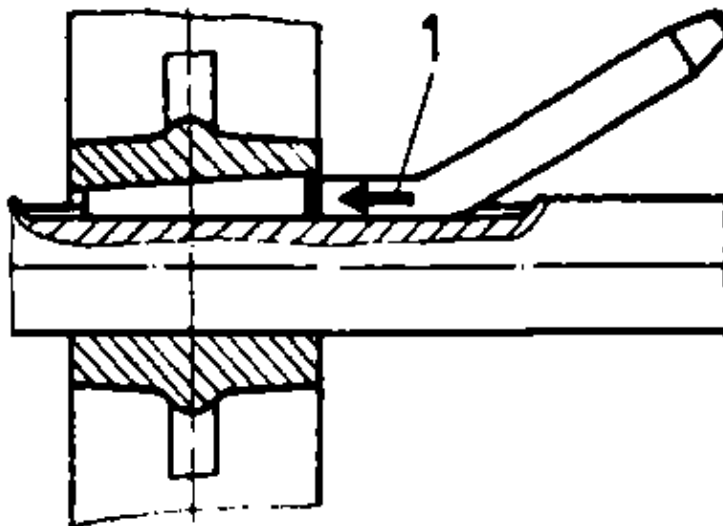

Figure 25 – Pressing-in of the tapered driving key by means of cotter driver

1 pressing-in force

Long and big tapered driving keys are forced in by about sledges and with the help of light metal backings. Neither the wedge nor the shaft and hub must be damaged when the wedge is forced in.

Testing the joint

After the key is driven in it has to be made sure that

- the key fits tightly
- the hub is in the right place on the shaft
- the hub rotates in truth on the shaft.

By what techniques are the grooves made in the shafts?

By what techniques are the grooves made in the hubs?

What qualities of the individual parts have to be examined if a taper sunk key joint shall be made?

What kind of fit is required between shaft and hub in case of taper sunk key joints?

6.2. Hollow Key and Flat Key Joints

- Preparation of the keyways:

Only hub keyways have to be made.

- Checking of the individual parts:

The external condition and accuracy to size of shaft and hub as well as of the hub keyway have to be inspected.

- Deburring of the individual parts:

Key and hub keyway have to be deburred.

- Fitting the key into the keyway:

By way of trial it is found out whether the key fits in the joined machine parts.
When using flat keys, the shaft has to be flattened corresponding to the bottom surface of the wedge.

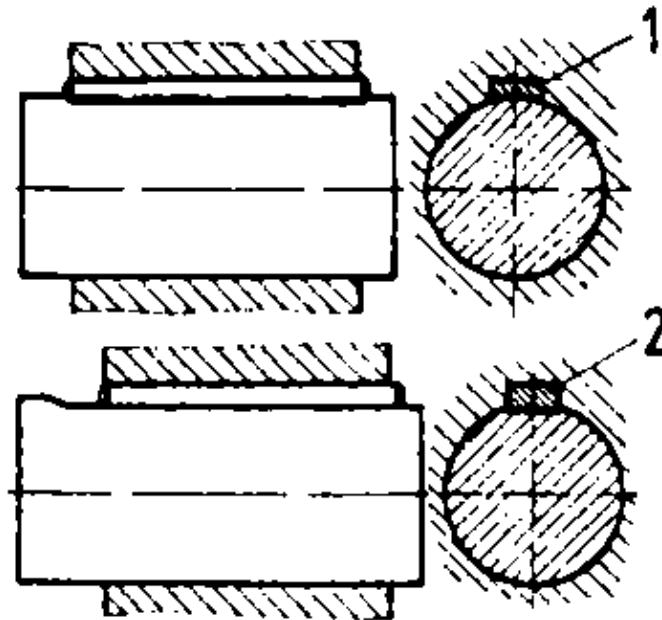

Figure 26 – Fitted in hollow and flat keys

1 hollow key, 2 flat key

- Assembling the individual parts:

Shaft and hub are slightly greased and put together. The key is driven in by a locksmith's hammer and a cotter driver.

- Testing of the joint:

After assembly, the firm fit of key and hub as well as the true running are tested.

6.3. Tangential Key Joint

- Preparation of the keyways:

In each shaft and hub two oblique (tangential) keyways have to be made which are staggered by 120° .

- Checking of the individual parts:

The external condition and accuracy to size of shaft and hub as well as of the keyways have to be checked.

- Deburring of the individual parts:

Wedges and keyways have to be deburred.

- Fitting the keys into the keyway:

At first, keys 2 and 4 are put in, then keys 1 and 3; they are slightly forced in and reworked after their bearing contact pattern has been inspected.

The inclined surfaces of keys 1 and 2 as well as 3 and 4 must be placed against one another for assembly.

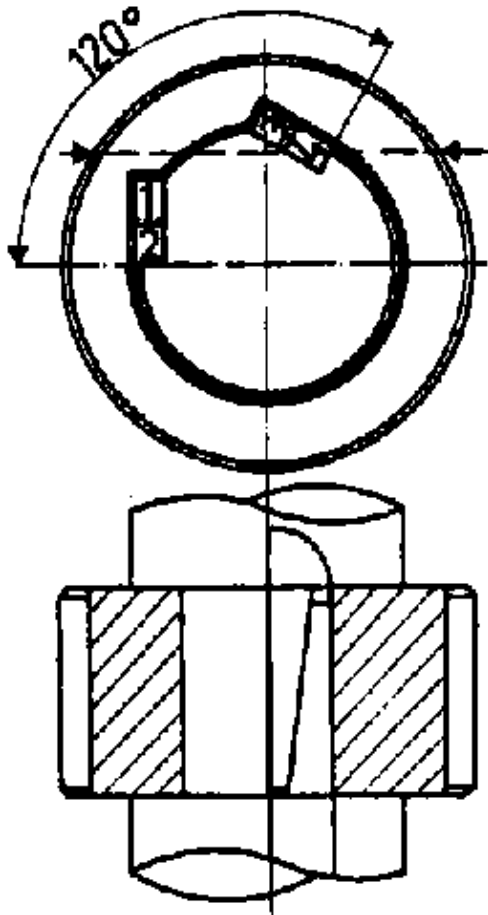

Figure 27 – Fitted in tangential keys

– Assembling the individual parts:

Shaft and hub are slightly greased and put together.

After that, keys 2 and 4 are inserted and then keys 1 and 3 beaten in alternately.

– Testing of the joint:

After assembly, the firm fit of the keys and the hub as well as the true running have to be tested.

How is the fit of the keys examined?

What is tested after a shaft and hub joint is made?

6.4. Particularities when Making Conical Connections

– Taper sleeves are adapted to conical shaft butts attaining full bearing capacity by ink-marking and subsequent grinding and scraping.

– Taper pins as longitudinal keys are fitted in shaft and hub joints by the technique of reaming. For this purpose, shaft and hub are clamped and bored and then reamed by taper reamers. Attention has to be paid that the front ends of shaft and hub level with each other so that they are bored accurately on the line of the shaft circumference.

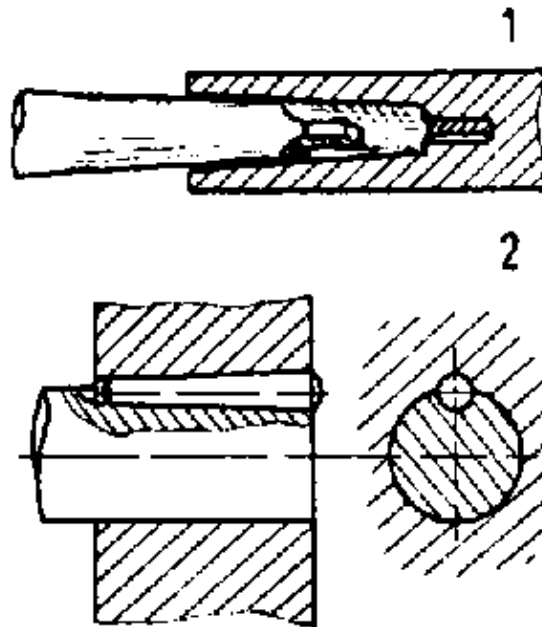

Figure 28 – Conical joints

1 taper shank in taper sleeve, 2 taper pin as key

6.5. Joining by Using Cotters

- Making of elongated holes:

By the techniques of milling or mechanical filing elongated holes with the required taper of the side faces are made in both machine parts.

- Assembling the individual parts:

The individual parts are deburred and cleaned and put together with the oblong holes being aligned.

- Fitting in the key:

The key is beaten in slightly (on trial) in order to find out the bearing capacity of the inclined surfaces.

- After having been reworked the key is forced into the elongated hole by systematic hammer blows.
- Shall the key stand heavy and changing loads it must be secured against coming loose.

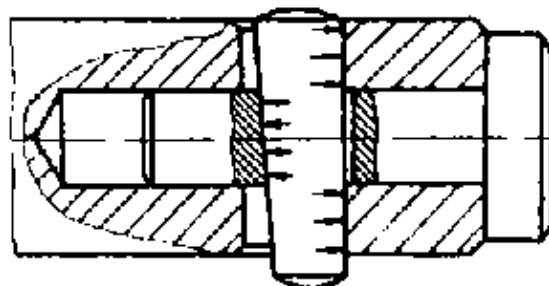

Figure 29 – Fitted in cotter

6.6. Joint Made by Using Tightening Keys

- Mounting the premanufactured individual parts:

The bearing shells are put into the mechanically made through hole. Thin sheet metal insets are placed between the two bearing shells.

The tightening key is put in such a way that a displacement of the key would cause also a displacement of one of the bearing shells.

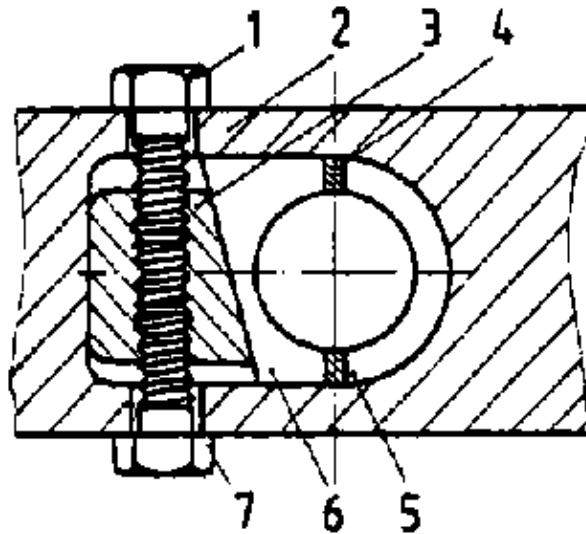

Figure 30 – Mounted adjusting key

1 adjusting screw, 2 casing, 3 tightening key, 4 plate insets, 5 bearing shell I, 6 bearing shell II

– Coarse adjustment of the tightening key:

The adjusting screw is screwed in and tightened till the bearing shells are pressed together. The locking screw is loosely screwed in – if tightened, it secures the tightening key against coming loose.

– Fine adjustment of the tightening key:

The shaft journal is put between the bearing shells. By tightening the adjusting screw the bearing shells are pressed together, but only to such an extent that a fine clearance remains between shaft and bearing shells.

If the shaft journal rattles, parts of the sheet metal insets have to be removed and the tightening key has to be retighten. Then, the tightening key is secured with the help of the locking screw.

7. Undoing of Keyed Joints

Machine parts which shall be dismantled and – after maintenance – shall be reassembled have to be marked before dismantling.

By this, they will be put in their right places after repair or maintenance.

Tapered driving keys, hollow keys, flat keys

These keys are removed by blows on a cotter driver or non-ferrous metal arbor (drift) opposite the driving-in direction.

Gib-head keys

Between hub and nose of the key the key extractor is driven and beaten through by hammer blows.

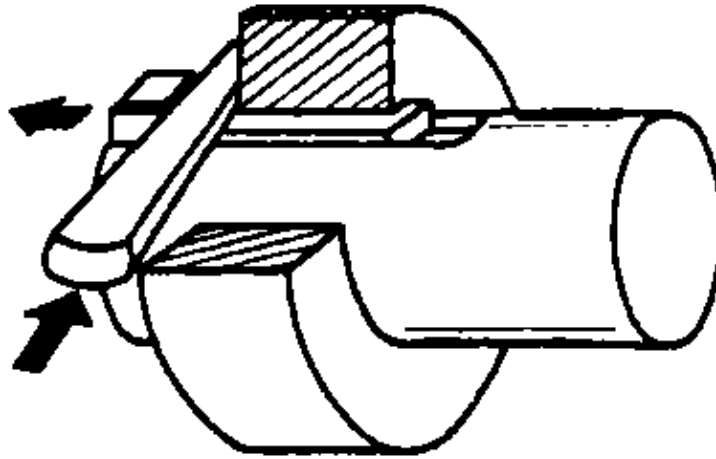

Figure 31 – Driving out of the gib-head key by cotter extractor

Laid-in keys, Woodruff key, tangential key

By means of puller shaft and hub are drawn apart, so that the joining elements can be taken out.

Taper sleeves

A cotter is inserted into the oblong hole of the taper sleeve and driven in by hammer blows.

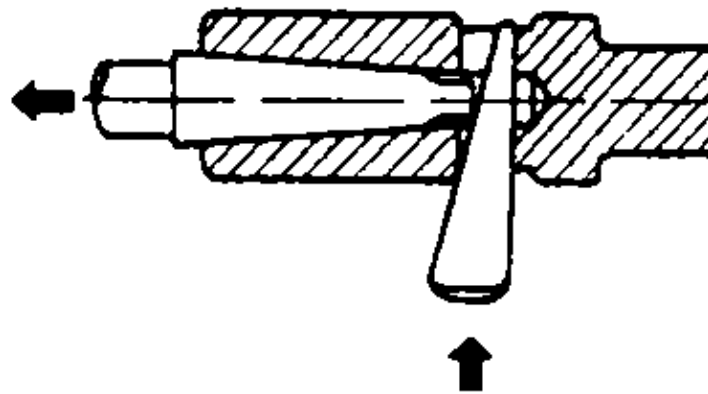

Figure 32 – Driving out of a taper shank by cotter

Taper pin used as a key

The joint is undone by drilling the taper pin out or by pulling the hub off by a puller.

Cotter and taper pin as a cotter

It is driven out with the help of a hammer and suitable non-ferrous metal arbor (drift) by blows opposite the driving-in direction.

Tightening key

The locking screw is loosened then, the tightening key can be loosened by the adjusting screw.

If the keyed joints appear to be too difficult to undo, the hub should be carefully heated up by a gas burner – make sure that the shaft does not become hot.

Then it is tried to drive or pull the key out.

If this is not possible, the shaft keyway, too, is heated up with the help of a second gas burner. Then the key can be driven out.

By heating up the hub, even very firm shaft and hub joints can be slackened so that they can be separated by a puller.

How is a tightening key fine-adjusted?

How are tapered driving keys loosened?

How are laid-in keys loosened?

**Knurling – Course: Techniques for Machining of Material. Instruction
Examples for Practical Vocational Training**

Table of Contents

<u>Knurling – Course: Techniques for Machining of Material. Instruction Examples for Practical Vocational Training</u>	1
<u>Introduction</u>	1
<u>Instruction example 7.1.: Locking screw</u>	2
<u>Instruction example 7.2.: Ring thread gauge</u>	4
<u>Instruction example 7.3.: Knurled screw</u>	7
<u>Instruction example 7.4.: Control knob</u>	10
<u>Instruction example 7.5.: Grip</u>	13

Knurling – Course: Techniques for Machining of Material. Instruction Examples for Practical Vocational Training

Institut für berufliche Entwicklung e.V.
Berlin

Original title:
Lehrbeispiele für die berufspraktische Ausbildung
“Rändeln und Kordeln”

Author: Horst Köth

First edition © IBE

Institut für berufliche Entwicklung e.V.
Parkstraße 23
13187 Berlin

Order No.: 90–33–3207/2

Introduction

The present booklet contains 5 selected training examples which are intended to help practising and consolidating knowledge and skills acquired in the working technique knurling.

In order to facilitate the preparation and execution of the work, the necessary materials, working, measuring and testing tools and accessories are stated for each training example.

For the training examples 1, 4 and 5 the steel is specified according to the value of its tensile strength in the unit “Megapascal” (MPa).

We also recommend knowledge required in addition to knowledge of knurling which should be repeated before starting with the work.

Explanations to the working drawings are given before the specification of the technological sequence.

The specified sequence of operations for the individual training examples gives the steps necessary for the production of the parts. This sequence of operations should be strictly observed if good quality is to be achieved.

For each training example a working drawing is attached showing the required shapes and dimensions of the workpiece.

It is also possible to select other parts with greater or smaller dimensional variations.

The admissible deviations for sizes with no indication of tolerances may be taken from the table below.

Nominal size	Admissible deviation in mm
0.5 – 6	± 0.1
6 – 30	± 0.2
30 – 120	± 0.3
120 – 315	± 0.5

Instruction example 7.1.: Locking screw

This example serves to practise straight knurling of simple cylindrical parts.

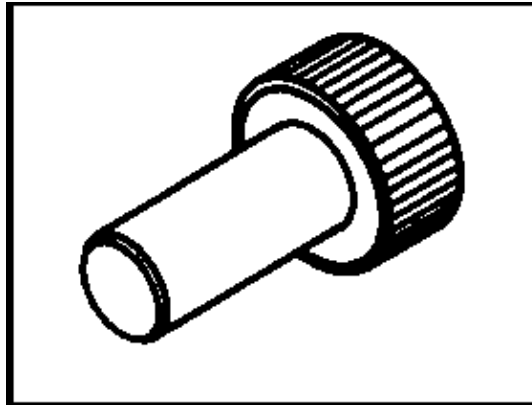

Material

St 42 (steel with tensile strength up to 420 MPa)

Dimensions

dia. 62 x 110 mm

Working tools

Right-bent roughing tool, chuck key, straight knurling tool with straight pitch ($t = 0.8$ mm)

Measuring and testing tools

Vernier caliper

Accessories

Hard chuck jaws, supporting plates, coolant and lubricant

Required previous knowledge

Reading of drawings, measuring and testing, behaviour of material in chipless shaping, longitudinal turning and facing, use of coolants and lubricants

Explanations to the working drawing

M 16: M = metric thread. 16 = nominal diameter

Straight knurling 0.8: straight knurling = straight wheel
0.8 = tooth pitch 0.8 mm

Sequence of operations

Remarks

- | | |
|---------------------------|---|
| 1. Dimensional inspection | dia. 30 x 14 mm |
| 2. Clamping of workpiece | Chucking – chuck jaws to chuck on dia. 16 mm, 30 mm deep. |

- | | | |
|-----|--|--|
| 3. | Clamping of tool to produce knurling diameter | Right-bent roughing tool |
| 4. | Setting of cutting values for turning the outside diameter | For steel $v = 80$ m/min.
Surface finished. |
| 5. | Producing the knurling diameter | By experience it is known that diameter of finished part becomes bigger by approx. half the pitch (1/2 mm) of knurling tool, i.e. diameter to be turned smaller – $d = 30$ mm less 0.4 mm = <u>29.6 mm</u> . |
| 6. | Tool change for producing knurling | Width of knurling tool according to width of workpiece.
Knurling tool to be clamped approx. 1 mm below centre and at right angle to workpiece axis. |
| 7. | Setting of cutting values for straight knurling | For steel $v = 6$ to 10 m/min.
For St 42 $v = 10$ m/min to be selected. |
| 8. | Straight knurling of diameter | To be cooled and lubricated with diluted soluble oil or cutting oil (heavy pressing force results in high friction and heat). |
| 9. | Tool change for producing the chamfers | Right-bent roughing tool. |
| 10. | Chamfering of workpiece | Chamfering of workpiece after knurling is necessary because material is forced towards end faces, both ends $0.8 \times 45^\circ$ (chamfer = t). |
| 11. | Unloading of workpiece | |
| 12. | Dimensional inspection | Dimensional and visual inspection (cleanliness of knurling grooves).
Wheel of knurling tool to be cleaned by wire brush. |

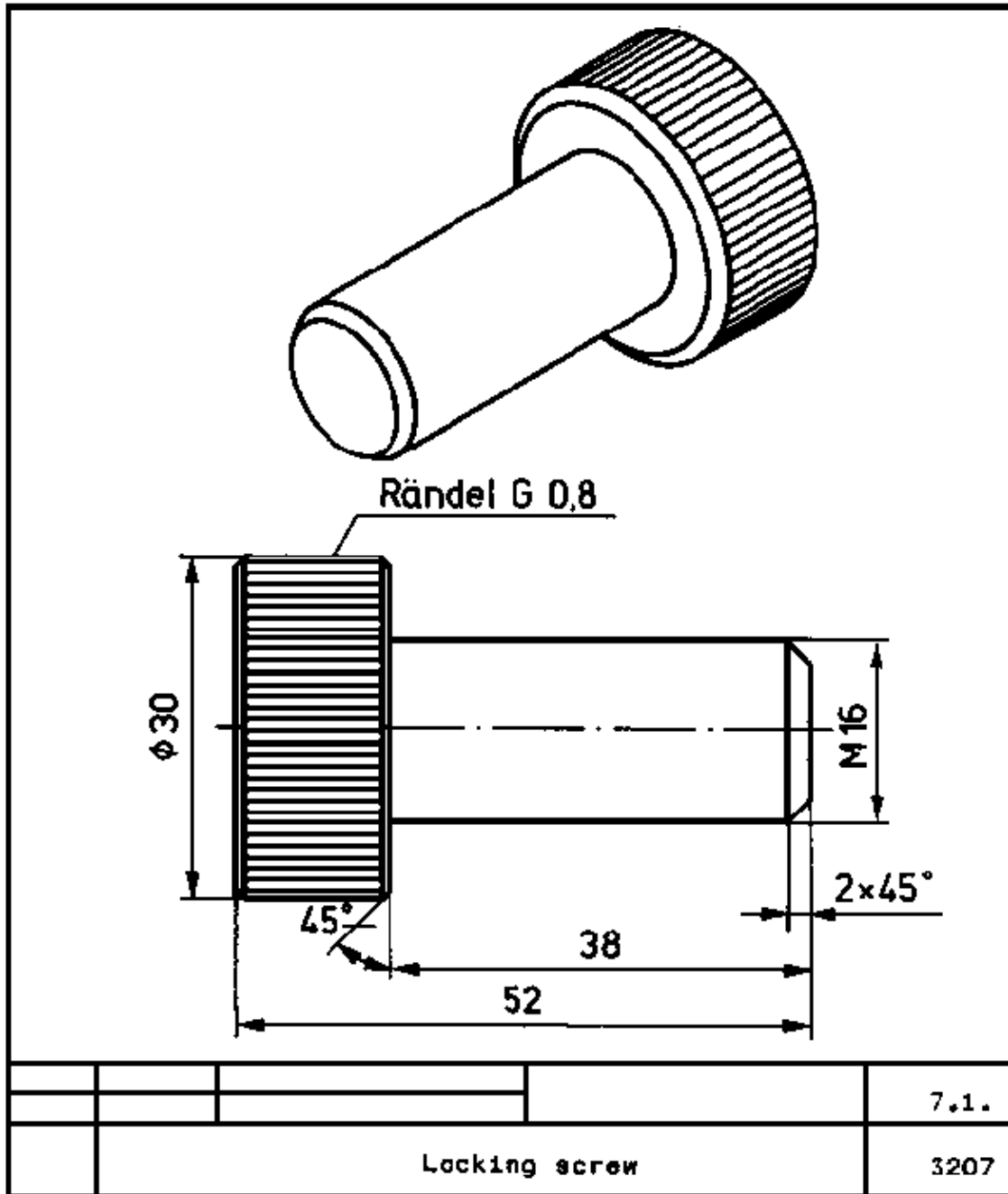

Instruction example 7.2.: Ring thread gauge

This example serves to practise spiral knurling of simple cylindrical parts.

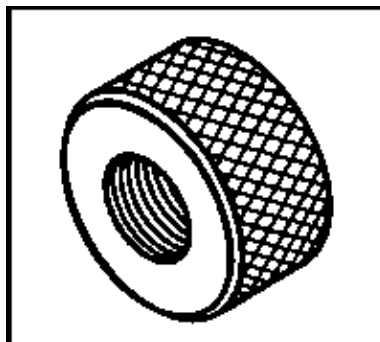

Material

16 Cr Mn 5 (low–alloy steel, alloy constituents: 0.16% carbon, 1.25% chromium, less than 1% manganese, rest iron)

Dimensions

dia. 52 x 27 mm

Working tools

Right–bent roughing tool, chuck key, spiral knurling tool with groove pitch ($t = 1.2$ mm)

Measuring and testing tools

Vernier caliper

Accessories

Hard chuck jaws, arbor M 24, supporting plates, coolant and lubricant

Required previous knowledge

Reading of drawings, measuring and testing, behaviour of material in chipless shaping, longitudinal turning and facing, use of coolants and lubricants

Explanations to the working drawing

M 24: M = metric thread, 24 = nominal diameter

Spiral knurling 1.2: Spiral knurling: spiral knurling wheels at an angle of 30° .

1.2 = tooth pitch (groove distance) 1.2 mm

Sequence of operations

Remarks

- | | |
|---|--|
| 1. Dimensional inspection | |
| 2. Clamping of workpiece | Chucking (hard jaws) – centre. Use arbor M 24 to mount ring thread gauge. Arbor to be produced with shoulder to give necessary distance between workpiece and chuck. |
| 3. Clamping of tool to produce knurling diameter | Right–bent roughing tool. |
| 4. Setting of cutting values for longitudinal turning | |
| 5. Producing the knurling diameter | $t/2$ mm: $d = 50$ mm less 0.6 mm = <u>49.4 mm</u> |
| 6. Tool change for producing the knurling | Spiral knurling tool to be clamped approx. 1 mm below centre and at right angle to workpiece axis. |

Matching edge bearing must fit well.

7. Setting of cutting values for spiral knurling
 $v = 6 - 10$ m/min. For low-alloy steel
 $v = 6$ m/min to be selected.
8. Spiral knurling of diameter
To be cooled and lubricated with soluble oil or cutting high (heavy pressing force results in high friction and heat). When longitudinal feed is used, feed must correspond to spiral-knurling pitch to avoid overlapping.
9. Tool change for chamfering
Right-bent roughing tool.
10. Chamfering of workpiece
Chamfers $1.2 \text{ mm} \times 45^\circ$ each (chamfer = t).
Chamfering to be done after knurling because material is forced towards end faces.
 v like for producing outside diameter.
11. Unloading of workpiece
12. Dimensional inspection
Dimensional and visual inspection. Wheels of spiral knurling tool to be cleaned by wire brush.

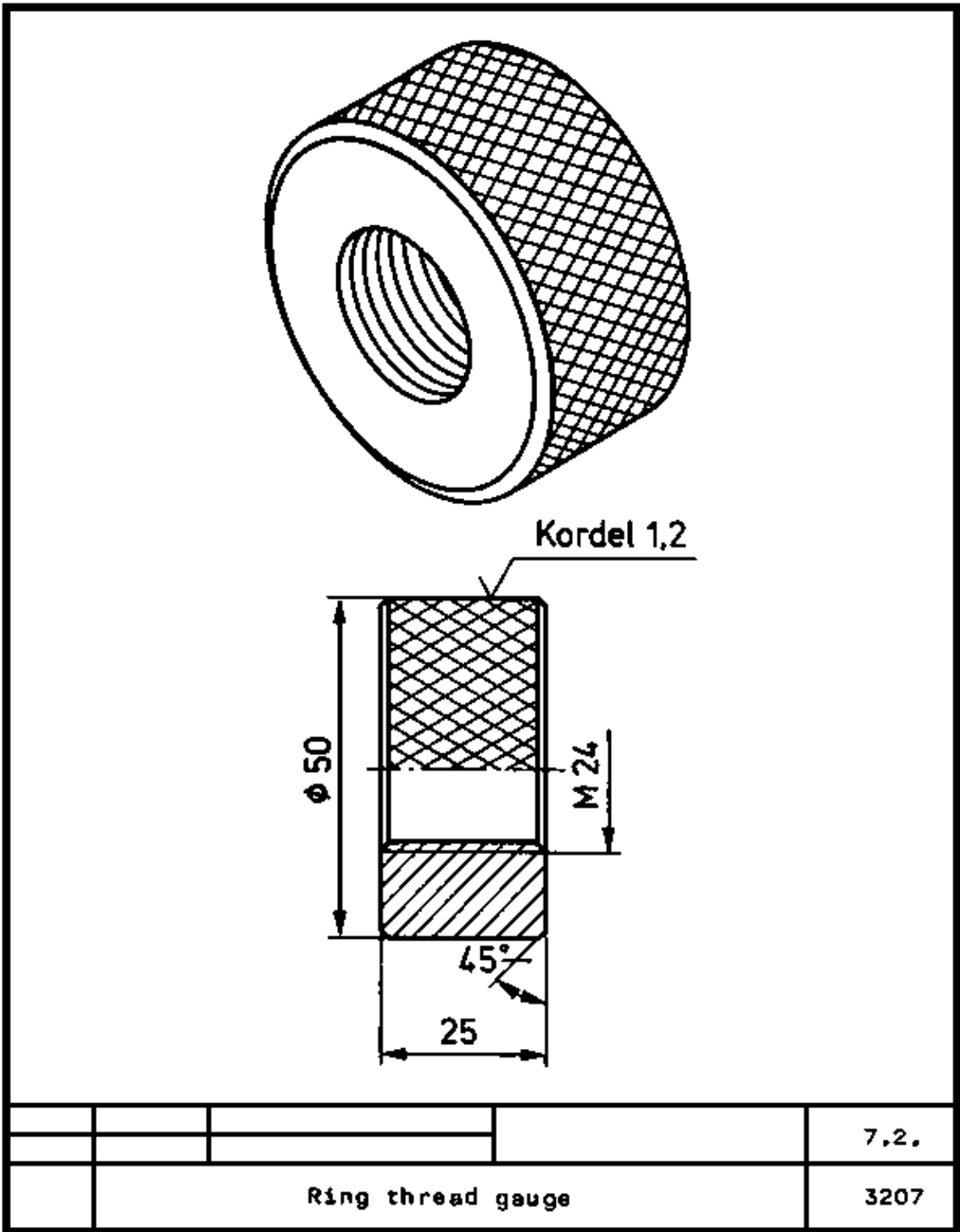

Instruction example 7.3.: Knurled screw

This example serves to practise cross knurling of non-metallic materials.

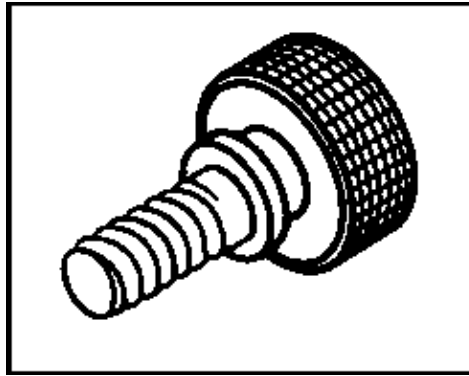

Material

Thermosetting plastics

Dimensions

dia. 34 x 58 mm

Working tools

Right-bent roughing tool, chuck key, cross knurling tool with groove pitch 0.8 mm (used for hard rubber, plastics)

Measuring and testing tools

Vernier caliper

Accessories

Soft chuck jaws which can be internally turned, supporting plates, coolant and lubricant

Required previous knowledge

Reading of drawings, measuring and testing, behaviour of material in chipless shaping, internal turning of jaws, longitudinal turning and facing, use of coolants and lubricants

Explanations to the working drawing

M 12: M = metric thread, 12 = nominal diameter

R 3: 3 mm radius

Cross knurling 0.8: Cross knurling = tooth pitch crossing at 90°, 0.8 = tooth pitch of 0.8 mm

All surfaces finished.

Sequence of operations

Remarks

- | | |
|--|--|
| 1. Dimensional inspection | |
| 2. Clamping of workpiece | Chucking – soft chuck jaws to be internally turned for dia. 12 mm. |
| 3. Clamping of tool to produce knurling diameter | Right-bent roughing tool. |

- | | |
|---|--|
| 4. Setting of cutting values | |
| 5. Producing the knurling diameter | $t/2: d = 32 \text{ mm less } 0.4 \text{ mm} = \underline{31.6 \text{ mm}}$ |
| 6. Tool change for producing knurling | Cross knurling tool to be clamped approx. 1 mm below centre and at right angle to workpiece axis. |
| 7. Setting of cutting values for cross knurling | $v = 6 - 10 \text{ m/min}$ – since soft material
$v = 10 \text{ m/min}$ to be selected. |
| 8. Cross knurling of diameter | To be cooled and lubricated with diluted soluble oil or petroleum. |
| 9. Tool change for chamfering | Right-bent roughing tool |
| 10. Chamfering of workpiece | Chamfers $0.8 \times 45^\circ$ each (chamfer = t).
Chamfering after knurling because material is also forced towards end faces.
v like for turning of outside diameter |
| 11. Unloading of workpiece | |
| 12. Dimensional inspection | Dimensional and visual inspection (cleanliness of grooves). Cross knurling wheel to be cleaned by wire brush. |

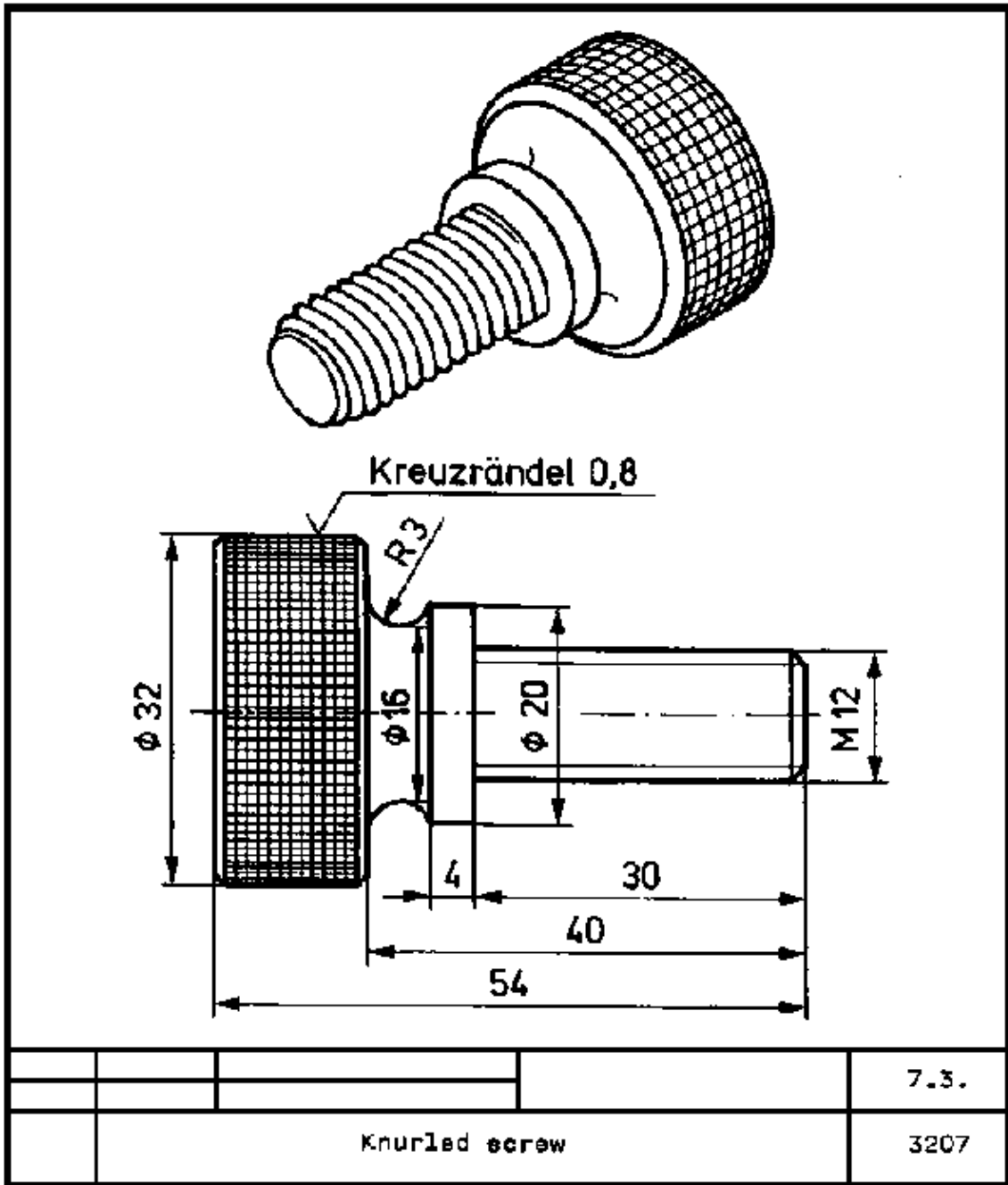

Instruction example 7.4.: Control knob

This example serves to practise straight knurling of convex parts.

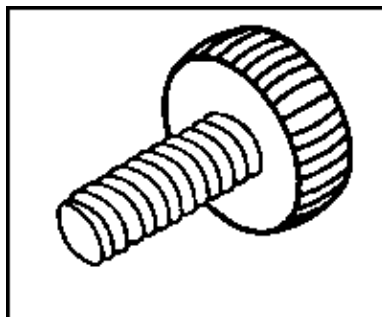

Material

St 34 (St = steel, 34 = tensile strength up to 340 MPa)

Dimensions

dia. 44 x 65 mm

Working tools

Right–offset side–cutting tool, radius turning tool, chuck key, hollow (concave) knurling tool

Measuring and testing tools

Vernier caliper, radius gauge

Accessories

Hard chuck jaws, supporting plates, coolant and lubricant

Required previous knowledge

Reading of drawings, measuring and testing, behaviour of material in chipless shaping, longitudinal turning and facing, use of coolants and lubricants

Explanations to the working drawing

M 16: M = metric thread, 16 = nominal diameter

Straight knurling K 1.0: K = hollow (concave) knurling wheel 1.0 = tooth pitch 1 mm

All surfaces finished.

<u>Sequence of operations</u>	<u>Remarks</u>
1. Dimensional inspection	
2. Clamping of workpiece	Chucking in hard chuck jaws 40 mm deep.
3. Clamping of tool to produce outside diameter	Right–offset side–cutting tool.
4. Setting of cutting values	
5. Producing the outside diameter	$t/2: d = 42 \text{ mm less } 0.5 \text{ mm} = \underline{41.5 \text{ mm}}$
6. Tool change for producing the radius	Form turning tool to be selected according to radius of knurling tool.
7. Setting of cutting values	Form turning tool is made of high–speed steel – $v = 25 - 50 \text{ m/min.}$ $v = 25 \text{ m/min}$ to be selected for form turning.

- | | | |
|-----|---------------------------------------|--|
| 8. | Producing the radius | Radius turning tool to be in centre position. |
| 9. | Tool change for producing knurling | Straight knurling tool to be clamped approx. 1 mm below centre and at right angle to workpiece axis. |
| 10. | Setting of cutting values | $v = 6 - 10$ m/min, since concave knurling wheel
$v = 6$ m/min to be selected. |
| 11. | Straight knurling of diameter | To be cooled and lubricated with soluble oil or cutting oil. First knurling to be done with one feed setting, if possible.
Tool to be positioned over full width – central position is essential
Operation must not last longer than necessary since surface gets harder and more brittle because of pressure. |
| 12. | Deburring of edges of knurled portion | Material is forced towards end faces forming burr. |
| 13. | Unloading of workpiece | |
| 14. | Dimensional inspection | Dimensional and visual inspection (cleanliness of knurling grooves).
Knurling wheel to be cleaned by wire brush. |

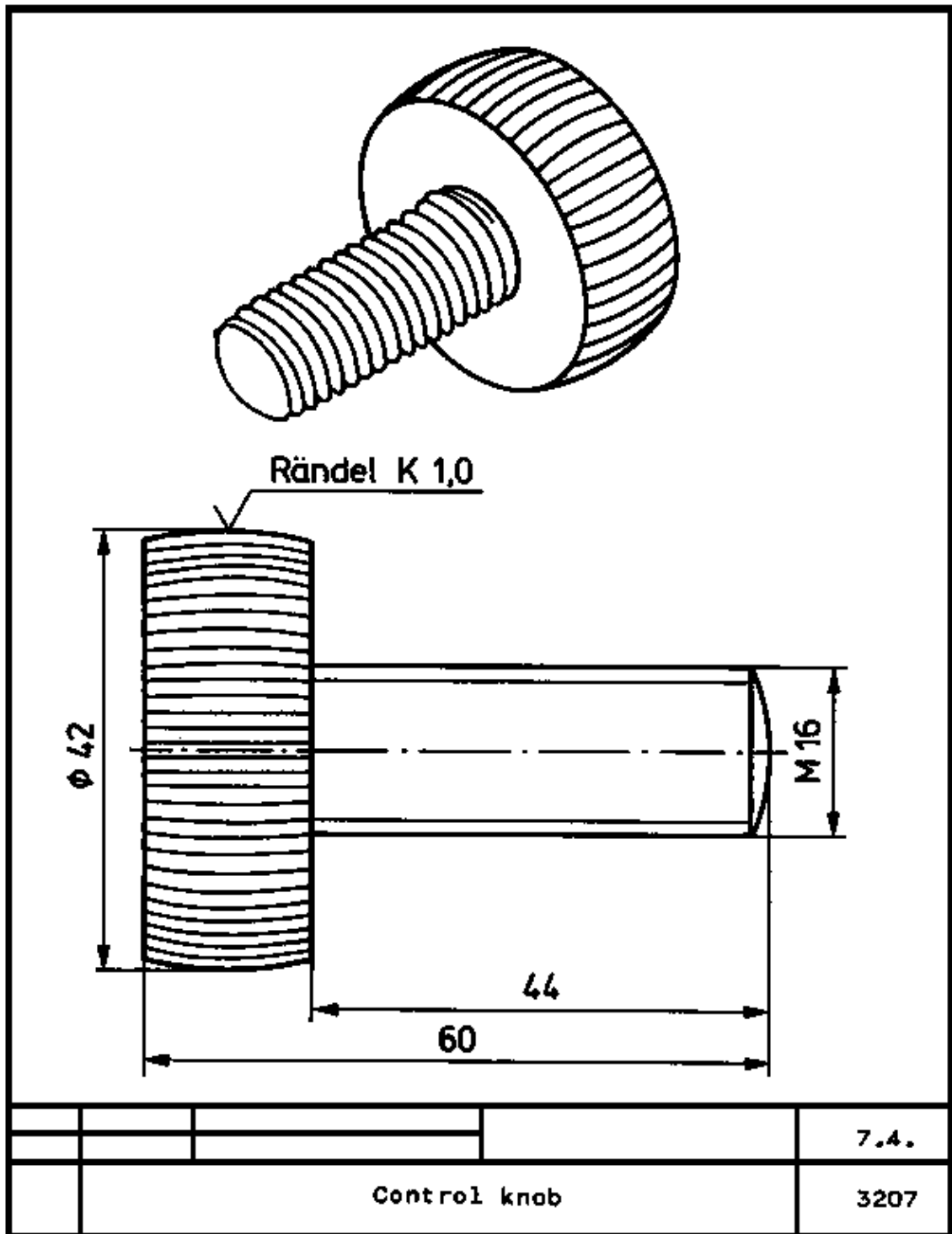

Instruction example 7.5.: Grip

This example serves to practise spiral knurling of long parts by means of the longitudinal feed.

Material

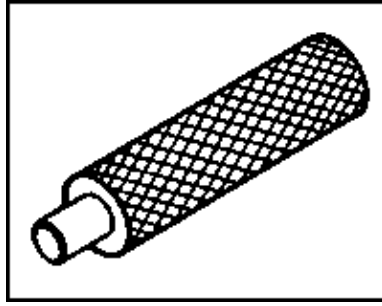

St 36 (steel with minimum tensile strength of up to 360 MPa)

Dimensions

dia. 26 x 110 mm

Working tools

Right-bent roughing tool, boring tool for corner work, chuck key, spiral knurling tool with groove pitch (t = 1.0 mm)

Measuring and testing tools

Vernier caliper

Accessories

Soft chuck jaws, supporting plates, live centre

Required previous knowledge

Reading of drawings, measuring and testing, behaviour of material in chipless shaping, internal turning of jaws, longitudinal turning and facing, use of coolants and lubricants

Explanations to the working drawing

Spiral knurling 1.0: Spiral knurling: spiral knurling wheels at an angle of 30°
 1.0 = tooth pitch (groove distance) 1 mm

Sequence of operations

Remarks

- | | | |
|----|--|---|
| 1. | Dimensional inspection | |
| 2. | Internal turning of soft jaws | Boring tool for corner work, depth 15 mm for dia. 12 mm |
| 3. | Clamping of workpiece | Chucking and with life centre |
| 4. | Clamping of tool to produce knurling diameter | Right-bent roughing tool |
| 5. | Setting of cutting values for longitudinal turning | |

- | | | |
|-----|---|--|
| 6. | Producing the knurling diameter | $t/2: d = 24 \text{ mm less } 0.5 \text{ mm} = \underline{23.5 \text{ mm}}$ |
| 7. | Tool change for producing knurling | Spiral knurling tool to be clamped approx. 1 mm below centre and at right angle to workpiece axis.
Matching edge bearing must fit well. |
| 8. | Setting of cutting values for spiral knurling | $v = 6 - 10 \text{ m/min}$, simple steel –
$v = 10 \text{ m/min}$ to be selected. |
| 9. | Spiral knurling of diameter | To be cooled and lubricated with diluted soluble oil – high pressing force and long portion result in high friction and heat. Starting position of tool not to be over full width immediately. Longitudinal feed must be according to spiral–knurling pitch to avoid overlapping. First knurling with one feed setting. Operation not to last longer than necessary because material gets harder and more brittle by cold forming. |
| 10. | Tool change for chamfering | Right–bent roughing tool. |
| 11. | Chamfering of workpiece | Chamfers $1 \times 45^\circ$ (chamfer = t)
v like for producing the knurling diameter. |
| 12. | Unloading of workpiece | |
| 13. | Dimensional inspection | |

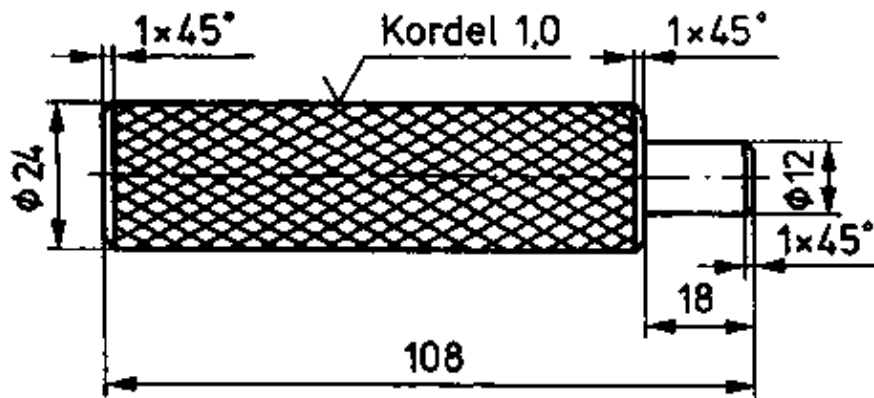
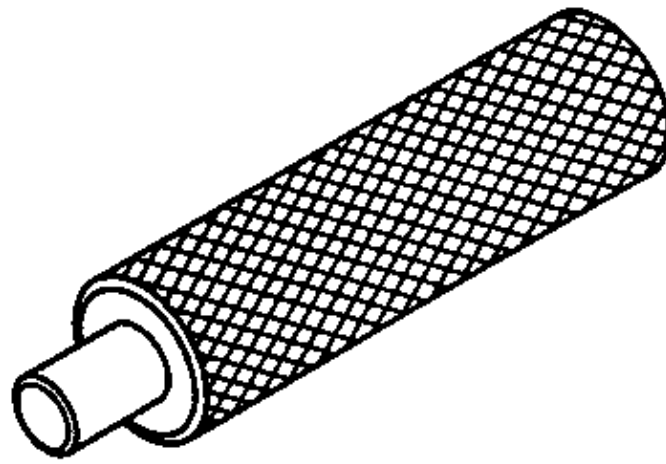

			7.5.
	Grip		3207

**Knurling – Course: Techniques for Machining of Material. Trainees'
Handbook of Lessons**

Table of Contents

Knurling – Course: Techniques for Machining of Material. Trainees' Handbook of Lessons	1
1. Purpose and meaning of knurling.....	1
2. Design and types of knurling tools.....	2
3. Preparation of knurling.....	5
4. Straight knurling of small widths on simple cylindrical parts.....	8
5. Spiral knurling of small widths.....	10
6. Cross knurling of small widths.....	11
7. Straight knurling of convex parts.....	11
8. Spiral knurling of big widths.....	12

Knurling – Course: Techniques for Machining of Material. Trainees' Handbook of Lessons

Institut für berufliche Entwicklung e.V.
Berlin

Original title:
Arbeitsmaterial für den Lernenden
"Rändeln und Kordeln"

Author: Horst Köth

First edition © All surfaces finished.

Institut für berufliche Entwicklung e.V.
Parkstraße 23
13187 Berlin

Order No.: 90-35-3207/2

1. Purpose and meaning of knurling

Cylindrical parts, such as screw heads, round nuts, gripping surfaces on measuring tools and all kinds of handles or grips which have to be gripped firmly, must have roughened gripping surfaces. Good grip of such gripping surfaces of operating elements is ensured by providing them with knurled portions. According to the patterns produced, the knurled portions are called straight knurling, cross knurling or spiral knurling.

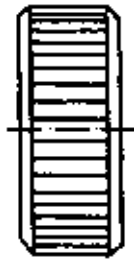

Figure 1 Straight knurling

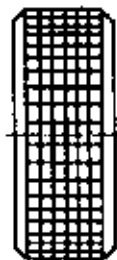

Figure 2 Cross knurling

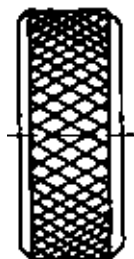

Figure 3 Spiral knurling

This non-cutting technique is no real turning operation. As an embossing operation it belongs to the metal forming techniques, but it is done on the lathe and is a very simple and cheap method.

Gripping surfaces thus produced are sufficient in terms of

- accuracy to size
- shape (good grip)
- surface finish and
- fit.

2. Design and types of knurling tools

By the knurling technique the outer surface of the parts is formed by means of a single-wheel or double-wheel knurling holder.

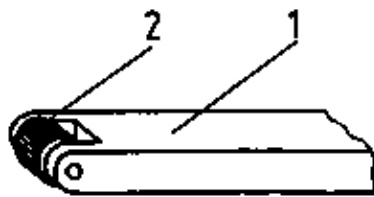

Figure 4 Straight knurling holder

- 1 knurling holder
- 2 knurling wheel

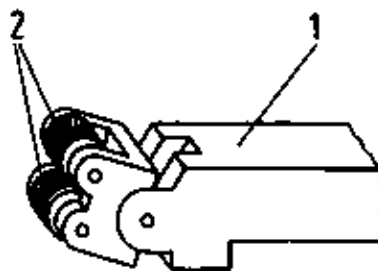

Figure 5 Spiral knurling holder

- 1 knurling holder
- 2 knurling wheels

The tools are toothed steel wheels (or rolls or knurls) pressing the pattern into the surface.

Straight knurling holders are solid and have one wheel (see Fig. 4). The wheel should run with a little clearance in the borehole as well as in the holder.

Straight knurlings are produced by means of straight or hollow knurling wheels (mostly cylindrical) with one wheel only in the knurling holder.

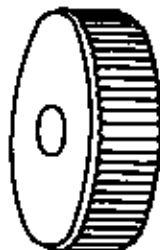

Figure 6 Straight knurling wheel

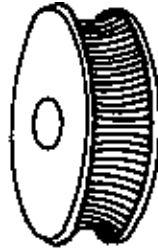

Figure 7 Hollow (concave) knurling wheel

The spiral knurling holder, the head of which is tiltable, holds two wheels (see Fig. 5).

Spiral knurling holders have a special matching edge bearing which must fit well at the upper edge of the tool slide when clamping so as to prevent the holder from being forced away during the operation.

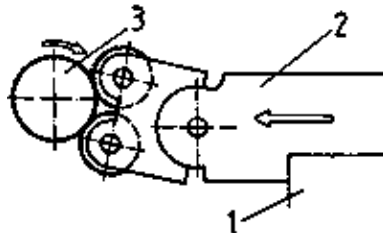

Figure 8 Spiral knurling tool – clamping with matching edge bearing

- 1 matching edge
- 2 knurling tool
- 3 workpiece

With cross knurlings the tooth pitches (grooves) are crossing at right angles. Cross knurlings are produced by knurling with two wheels having straight teeth in opposite directions.

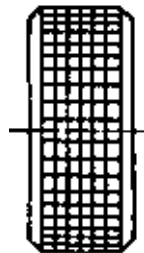

Figure 9 Cross knurling

Spiral knurlings are also produced by two wheels having tooth-type grooves in the form of a 30° right-hand or left-hand spiral (2 wheels with oppositely inclined teeth).

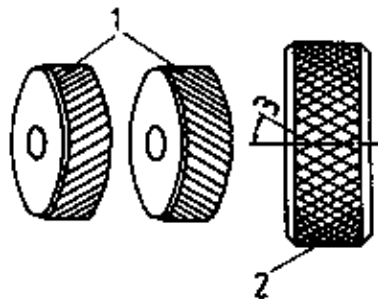

Figure 10 Spiral knurling

- 1 pair of knurling wheels
- 2 knurled portion
- 3 degrees (30°)

The groove distance is the pitch (t) which differs depending on the material, width and diameter of the workpiece.

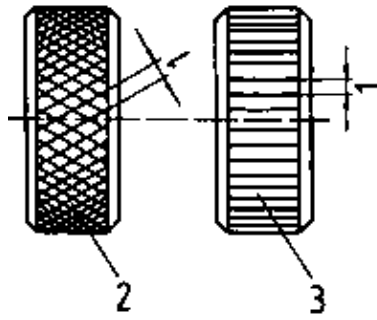

Figure 11 Form and pitch of teeth

- 1 pitch (groove distance t)
- 2 spiral knurling wheel
- 3 straight knurling wheel

Table 1 Recommended pitches for straight, cross and spiral knurlings

Dimensions of the workpiece		for any material	for hard rubber	for brass aluminium, fibre	for steel
		straight knurling 	cross knurling 	spiral knurling 	
Diameter d (mm)	Width b (mm)	Pitch t (mm)			
up to 8	any width	0.5	0.6	0.6	0.6
8...16	up to 2	0.5	–	–	–
	2...6	0.6	0.6	0.6	0.8
16...31	up to 2	0.5	–	–	–
	2...6	0.6	0.6	0.6	0.8
	more than 6	0.8	0.8	0.8	1.0
32...64	up to 6	0.6	0.6	0.6	0.8
	6...14	0.8	0.8	0.8	1.0
	more than 14	1.0	1.0	1.0	1.2
64...100	up to 6	0.8	0.8	0.8	0.8
	6...14	0.8	0.8	0.8	1.0
	14...30	1.0	1.0	1.0	1.2
	more than 30	1.2	1.2	1.2	1.6
more than 100	up to 2	0.8	–	–	–

	2...6	0.8	0.8	0.8	1.0
	6...14	1.0	1.0	1.0	1.2
	14...30	1.0	1.2	1.2	1.6
	more than 30	1.2	1.6	1.6	2.0

The knurling wheels are made of hardened tool steel and normally have a diameter of 15 – 20 mm. The teeth are similar to small cutting edges of tools.

Recommended pitches of straight, cross and spiral knurlings are given in the following table.

3. Preparation of knurling

Prior to knurling, all necessary working tools and materials are to be properly made available.

Setting up of the lathe basically involves the following steps:

Clamping/chucking of the workpiece for knurling

The parts to be knurled are mainly chucked in hard chuck jaws since the screws, knobs, etc. are mostly to be provided with a thread, i.e. they will be subjected to further machining.

Moreover, the gripping surfaces need not absolutely run true. If, however, true running is necessary or machined surfaces are to be protected, the parts are chucked in soft chuck jaws which are to be turned internally for this purpose.

Checking the diameter to be knurled for size.

By pressing the teeth into the workpiece, the diameter of the knurled portion will increase by approximately half the tooth pitch since there is no chip removal.

Therefore, the diameter of the workpiece must be turned smaller by 1 to 1/2 tooth pitch depending on the material.

$$(d_1 = d - t/2)$$

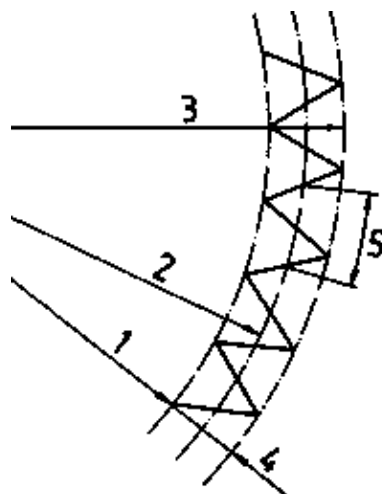

Figure 12 Increase in diameter

- 1 root circle
- 2 pitch circle
- 3 top circle
- 4 height
- 5 pitch t

Example: A steel part with a grip of $d = 30 \text{ mm}$ shall be spiral–knurled over a width of 40 mm. According to table 1 in section 2 the spiral–knurling pitch is 1 mm. By experience it is known that after knurling the diameter of the workpiece will be approx. $t/2$ bigger than before.

Therefore the grip is to be turned to

$$d_1 = d - t/2 \quad d_1 = 30 \text{ mm} - 0.5 \text{ mm} \quad d = \underline{29.5 \text{ mm}}$$

A grip of $d = 26 \text{ mm}$ shall be straight–knurled over a width of 20 mm.

What is the straight–knurling pitch and to which size is the nominal diameter to be turned?

Clamping of the tool for knurling

All straight and spiral knurling holders are generally to be clamped at right angles to the axis of rotation and to be positioned slightly below centre (approx. 1 mm).

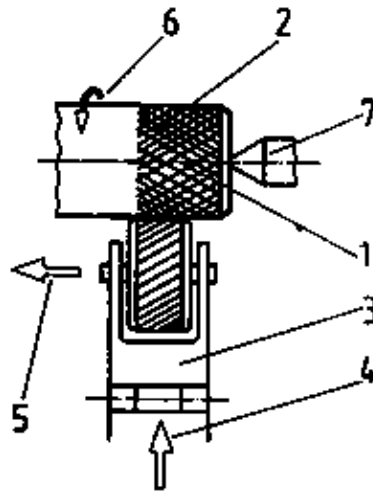

Figure 13 Clamping of the straight and spiral knurling holder at right angle to the axis of rotation

1 axis of rotation, 2 workpiece, 3 spiral knurling holder, 4 direction of tool pressure, 5 feed direction of tool, 6 direction of rotation of workpiece, 7 live centre of tailstock

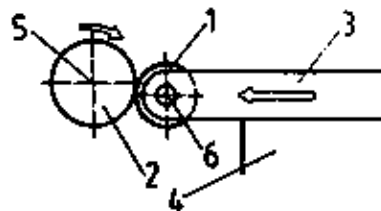

Figure 14 Clamping of straight knurling holder below centre

1 straight knurling wheel, 2 workpiece, 3 knurling holder, 4 tool support, 5 centre of workpiece, 6 centre of tool (below centre of workpiece)

Since the spiral knurling holder must exert double the pressing force compared to the straight knurling holder, it is more rigid and, moreover, provided with an edge to match the tool carrier (see Fig. 8).

All knurling wheels are fixed by unhardened steel pins.

Setting of the cutting values

Like with longitudinal turning and facing, the values to be set are determined by means of tables of recommended values depending on the kind of operation and on the lathe.

The rotational speeds of the workpieces should be a little lower than for turning with the same tool material (tool steel $v = 6 \dots 10$ m/min).

Example: A steel part (St 36) with a grip of $d = 30$ mm shall be straight-knurled over a width of 50 mm.

What is the rotational speed?

Cutting speed for tools of tool steel:

$v = 6 - 10$ m/min. Since St 36 has no special strength,
 $v = 10$ m/min is selected.

Given: $d = 30$ mm

Required: $n = ?$ r.p.m.

$\pi = 3.14$

$v = 10$ m/min

$$v = \frac{d \cdot \pi \cdot n}{1000}$$

$$n = \frac{v \cdot 1000}{d \cdot \pi} = \frac{10 \cdot 1000 \text{ mm/min}}{3.14 \cdot 30} = 106 \text{ r.p.m.}$$

If possible, the cutting depth should be produced in one feed setting.

Feed in axial direction will be necessary for longer spiral knurlings.

The longitudinal feed of the spiral knurling tools must always comply with the spiral-knurling pitch to avoid overlapping.

Making available coolant and lubricant

Cooling is absolutely necessary (normally by soluble oil or cutting oil) since the heavy pressing force produces heavy friction.

The following rules are to be observed:

- The knurling wheel must always be clean.
- All holders are to be clamped at right angles to the axis of rotation.
- The spiral knurling holder's matching edge bearing must be located at the upper edge of the tool slide to prevent the holder from being forced away.
- The straight knurling technique is used for all metals.
- The spiral knurling technique is used mainly for steel.
- The cross knurling technique is used for hard rubber, plastic material, etc.

What is the rotational speed for cross knurling of knobs of hard rubber with a gripping surface of $d = 24$ mm and 20 mm width?

Formula:
$$v = \frac{d \cdot \pi \cdot n}{1000 \text{ m/min}}$$

Given: _____

Required: _____

Calculation: _____

=====

What is the purpose of knurled portions?

Why is the diameter becoming bigger by knurling?

How are knurling tools to be serviced?

Why is a low cutting speed selected for knurling?

4. Straight knurling of small widths on simple cylindrical parts

By straight knurling gripping surfaces are produced, e.g on screws, round nuts and control knobs. Attention is to be paid to the following:

- The workpiece is clamped in a chuck. For longer parts the live centre is used as counter-support.
- Hard chuck jaws are mainly used.
- The knurling wheel is fixed in the holder by an unhardened steel pin (see Fig. 4).
- The knurling tool holder is to be clamped approx. 1 mm below centre and at right angle to the work-piece axis.
- Mislocation (oblique position) of the tool will result in failures and should be avoided.
- By operating the cross-slide screw, the tool is pressed against the workpiece.
- Firm and safe clamping of the workpiece and tool are important because of the high pressing force.
- If possible, the knurling should be produced in one feed setting.
- Sufficient cooling and lubrication are to be ensured.
- The edges of the workpiece are to be chamfered after knurling since the material is also pressed to the end faces. The amount of chamfer should be approximately equal to the pitch (chamfer = t).
- By visual inspection the grooves are checked for cleanliness.

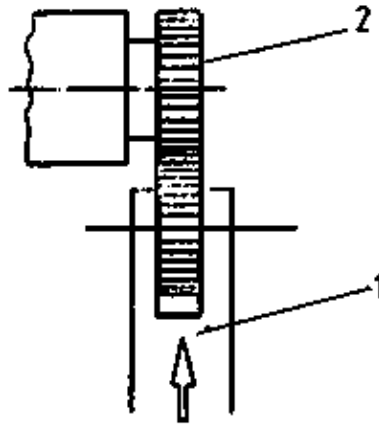

Figure 15 Working position of tool

- 1 straight knurling holder
- 2 workpiece

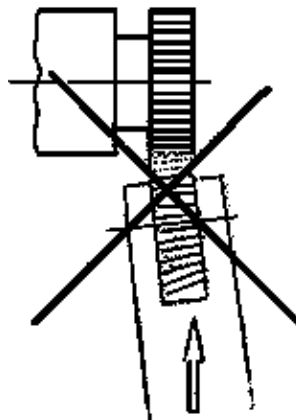

Figure 16 Misplacement of tool

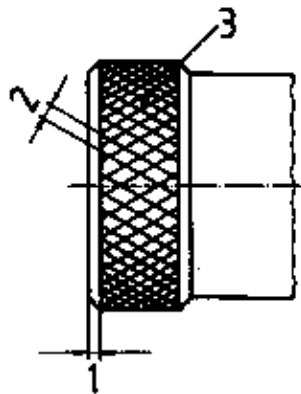

Figure 17 Chamfering of workpiece

- 1 chamfer
- 2 pitch
- 3 workpiece

What is the purpose of straight knurlings?

5. Spiral knurling of small widths

With this technique attention is to be paid to the following:

- The workpiece is mostly chucked in hard chuck jaws.
- The knurling wheels are fixed in the holder by unhardened steel pins (see Fig. 5).
- The knurling wheels must always be clean.
- The knurling holder is to be clamped approx. 1 mm below centre and at right angle to the workpiece axis.
- The matching edge bearing of the knurling tool must be perfectly fitting.
- By operating the cross–slide screw, the tool is pressed against the workpiece.
- If possible, the knurling should be produced in one feed setting.
- Good cooling and lubrication are to be ensured.
- The workpiece is to be chamfered after knurling.
- By visual inspection the knurling is checked.

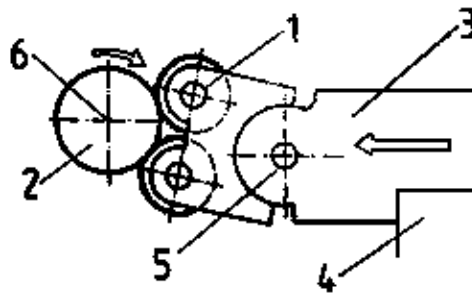

Figure 18 Clamping of spiral knurling holder below centre

1 spiral knurling wheel, 2 work–piece, 3 spiral knurling holder, 4 tool support (below centre of workpiece), 6 centre of workpiece

Measure and test only with the machine at rest or the workpiece unloaded.

Why are the workpieces provided with chamfers only after straight or spiral knurling?

How are spiral knurling tools to be clamped and serviced?

What safety requirements must be met in spiral knurling?

What tools are used for chamfering the workpieces?

6. Cross knurling of small widths

With this technique attention is to be paid to the following:

- The workpiece is mostly chucked in internally turned chuck jaws because material with low mechanical strength is knurled.
 - The pressing force depends on the material of the workpiece. If necessary and possible, a live centre is to be used as counter–support.
 - The knurling wheels are fixed in the holder by unhardened steel pin.
 - The knurling wheel must be clean.
 - The knurling holder is to be clamped (approx. 1 mm) below centre and at right angle to the workpiece axis.
 - By operating the cross–slide screw, the tool is pressed against the workpiece.
 - If possible, the knurling should be produced in one feed setting.
 - Good lubrication is to be ensured. Attention! The materials knurled (e.g. plastics) have other properties than steel!
- Sticky or smeary lubricants are not to be used.
- The workpiece is to be chamfered after knurling.
 - By visual inspection the knurling is checked.

Firm and safe clamping of the workpieces is essential because of high pressing forces generated in chipless forming.

7. Straight knurling of convex parts

With this technique attention is to be paid to the following:

- Mostly the workpiece is clamped in hard chuck jaws.
- Concave knurling is mainly applied for straight knurling of control knobs.
- The knurling wheel is fixed in the holder by an unhardened steel pin.
- The possibilities of application depend on the width of the portion to be knurled and the concave knurling wheels available.
- The knurling holder is to be clamped (approx. 1 mm) below centre and at right angle to the workpiece axis.
- By operating the cross–slide screw, the tool is pressed against the workpiece.
- If possible, the knurling should be produced in one feed setting.
- The knurling wheel must be clean.
- The workpiece is to be chamfered after knurling.
- The knurling is checked by visual inspection.

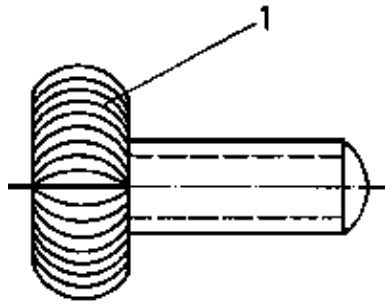

Figure 19 Control knob

1 gripping surface

8. Spiral knurling of big widths

With this technique attention is to be paid to the following:

- The workpiece is held in a chuck with live centre as counter–support.
- Depending on the state of machining of the parts, chucking is either in hard or in soft chuck jaws.
- The knurling wheels are fixed in the holder by unhardened steel pins.
- The knurling holder is to be clamped (approx. 1 mm) below centre and at right angle to the workpiece axis.
- The matching edge bearing of the tool must be properly located.
- By operating the cross–slide screw, the tool is pressed against the workpiece.
- The tool slide is laterally moved step by step or the longitudinal feed is used.
- The feed must comply with the spiral–knurling pitch to avoid overlapping.
- The tool must not be immediately applied to the full width.
- If possible, the knurling should be produced in one feed setting. For hard materials re–pressing will sometimes be necessary. In such cases the tool is not to be retracted but to continue in the same grooves to avoid overlapping.
- Basically the operation must not take longer than necessary since the cold forming process makes the material harder and more brittle.
- Good cooling and lubrication are to be ensured.
- The workpiece is to be chamfered after knurling.
- Measuring and testing is first by means of the vernier caliper, followed by visual inspection of the knurled portion.

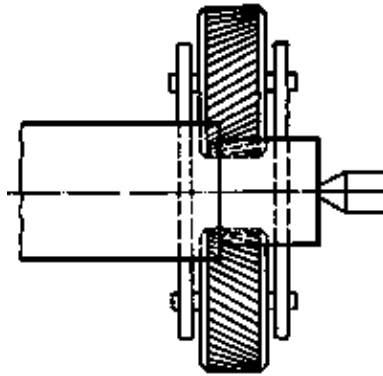

Figure 20 Spiral knurling of long parts

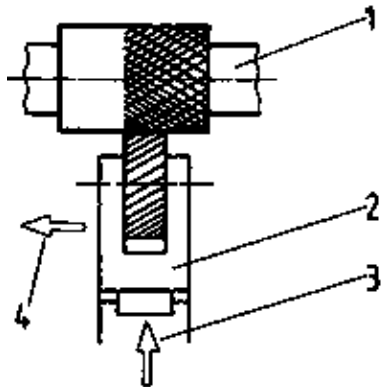

Figure 21 Spiral knurling of a wide portion with longitudinal feed

- 1 workpiece (long)
- 2 spiral knurling tool
- 3 pressing of tool
- 4 weed of tool

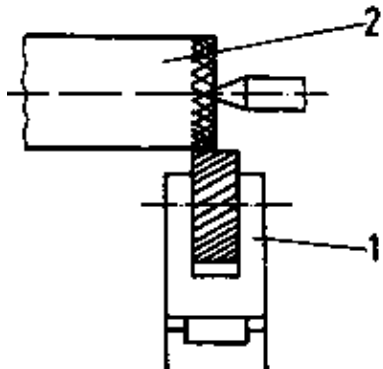

Figure 22 Tool not to be applied immediately to the full width

- 1 tool
- 2 workpiece

How are knurling tools constructed?

Which types of knurling do you know?

Explain the process of spiral knurling of wide portions!

**Setting-up and Operating of Regular Engine Lathes – Course:
Techniques for Machining of Material. Instruction Examples for
Practical Vocational Training**

Table of Contents

<u>Setting-up and Operating of Regular Engine Lathes – Course: Techniques for Machining of Material. Instruction Examples for Practical Vocational Training</u>	1
<u>Preface</u>	1
<u>Instruction example 1.1.: Handling the operation elements</u>	1
<u>Instruction example 1.2.: Selection of the working means</u>	3
<u>Instruction example 1.3.: Clamping and aligning of workpiece and tool</u>	5
<u>Instruction example 1.4.: Care and maintenance of the lathe</u>	9

Setting-up and Operating of Regular Engine Lathes – Course: Techniques for Machining of Material. Instruction Examples for Practical Vocational Training

Institut für berufliche Entwicklung e.V.
Berlin

Original title:
Lehrbeispiele für die berufspraktische Ausbildung
“Einrichten und Bedienen von Leit- und Zugspindeldrehmaschinen”

Author: Horst Köth

First edition © IBE

Institut für berufliche Entwicklung e.V.
Parkstraße 23
13187 Berlin

Order No.: 90–33–3201/2

Preface

The present material contains selected practical examples serving the purpose of applying and consolidating the knowledge, skills and abilities in the field of setting-up and operating lead-screw and feed shaft lathes.

The instructions given on the required sequences of operations, tools and auxiliary means form the basis for the systematic preparation of the setting-up and operating of leadscrew and feed shaft lathes. They are meant to make the sequence of operations as efficient as possible.

Previous knowledge is recommended, as this is the precondition for the operations to be carried out.

The previous knowledge should be checked and/or repeated before beginning the work. The given technological sequence of operations guarantees a good acquisition of the abilities to be learned. The sequence of the operations must be observed in order to achieve a good quality.

To the instruction examples 2 and 3, a workshop sketch is attached from which the required shapes and dimensions of the workpiece are to be seen. The necessary explanations of these sketches are placed in front of the technological sequence of operations of these examples.

The regulations on labour safety and fire protection have always to be observed. Hints in this connection are given only in special cases under the category of “Remarks”.

Instruction example 1.1.: Handling the operation elements

The operation elements of a regular engine lathe shall be actuated and their functions be realized.

Required previous knowledge

Read the drawing.

Sequence of operations

Remarks

1. Setting the rotational speed

Pay attention to the switching symbols, use existing rotational speed tables. Do switching exercises only with the machine at rest.

- | | |
|--|---|
| 2. Setting the feed | Pay attention to the switching symbols. If required, change interchangeable gears (interchangeable gear calculation). Switch off the main switch before opening the gear box. |
| 3. Setting the tool carrier with apron for cylindrical turning and/or thread cutting | Pay attention to differences in actuating the feed with thread cutting. Use the control shaft with long machines. |
| 4. Setting the cross slide for surfacing | Pay attention to the possibilities of manual and automatic feed. Take notice of feed and change of diameter (scale). |
| 5. Actuating the tool rest | Only manual feed possible. |
| 6. Setting the lathe tool holder | Examine clamping jaw and/or drawbolts. |
| 7. Actuating the tailstock | Fixing by tightening the clamping screw. Note adjustability, examine rubbing surfaces as to cleanliness. |
| 8. Switching on the machine | Observe safety regulations. Close chuck protection. Do not leave the chuck key inside. |
| 9. Switching off the machine | Do not stop the three-jaw chuck by hand. |

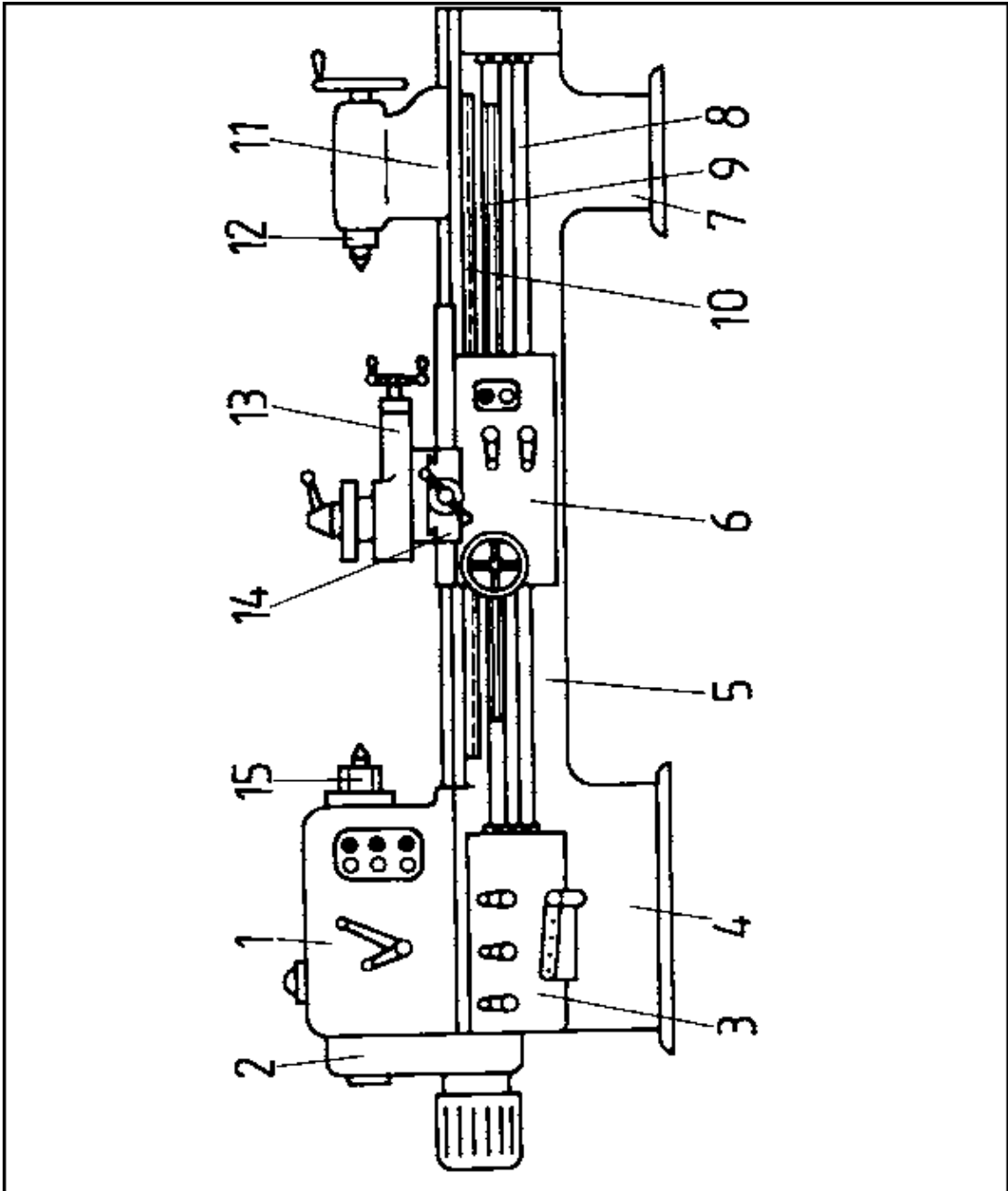

			1.1.
IBE	Handling the operation elements		3201

Handling the operation elements

Instruction example 1.2.: Selection of the working means

Demonstrated by the example of the manufacture of a pump shaft on a regular engine lathe.

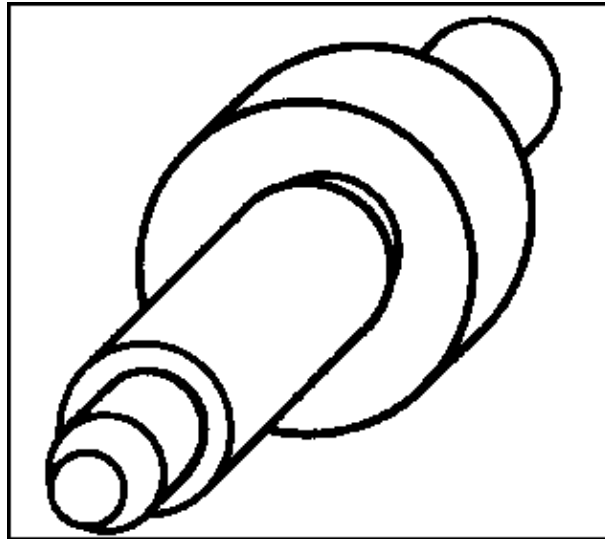

Required previous knowledge

Read the drawing, kinds and application of the clamping and auxiliary means.

Explanations of the workshop sketch

Surface quality: finished	M24 x 1.5	M = metric thread 24 = nominal diameter 1.5 = pitch
Ø 40 h7: 40 = nominal diameter h = standard shaft 7 = quality	A4 x 0.3	A = recess at the diameter 4 = width of the recess in mm 0.3 = depth of the recess below final size

Sequence of operations

Remarks

- | | |
|--|---|
| 1. Setting the driving plate | Length of the pin of the driving plate max. 24 mm, because the Ø 52, Ø 42 and Ø 24 are made at one setting. |
| 2. Selecting and clamping a firm centre | After having placed the centre, it has to be checked as to true running and, if necessary, to be corrected. |
| 3. Placing the lathe carrier at disposal | Select the lathe carrier corresponding to the diameter of the reception. |
| 4. Right curved side cutting turning tool (3 mm width) | Making available various shims for placing the tool at centre. |
| 5. Thread groove parting–off tool | To be selected according to the data of the drawing. |
| 6. Right–curved roughing lathe tool | Visual inspection of the cutting edges. |

7. Setting the tailstock

Pay attention to correct clamping.

8. Selecting the live centre

Select the machine taper corresponding to the quill of the tailstock, check the true running of the centre.

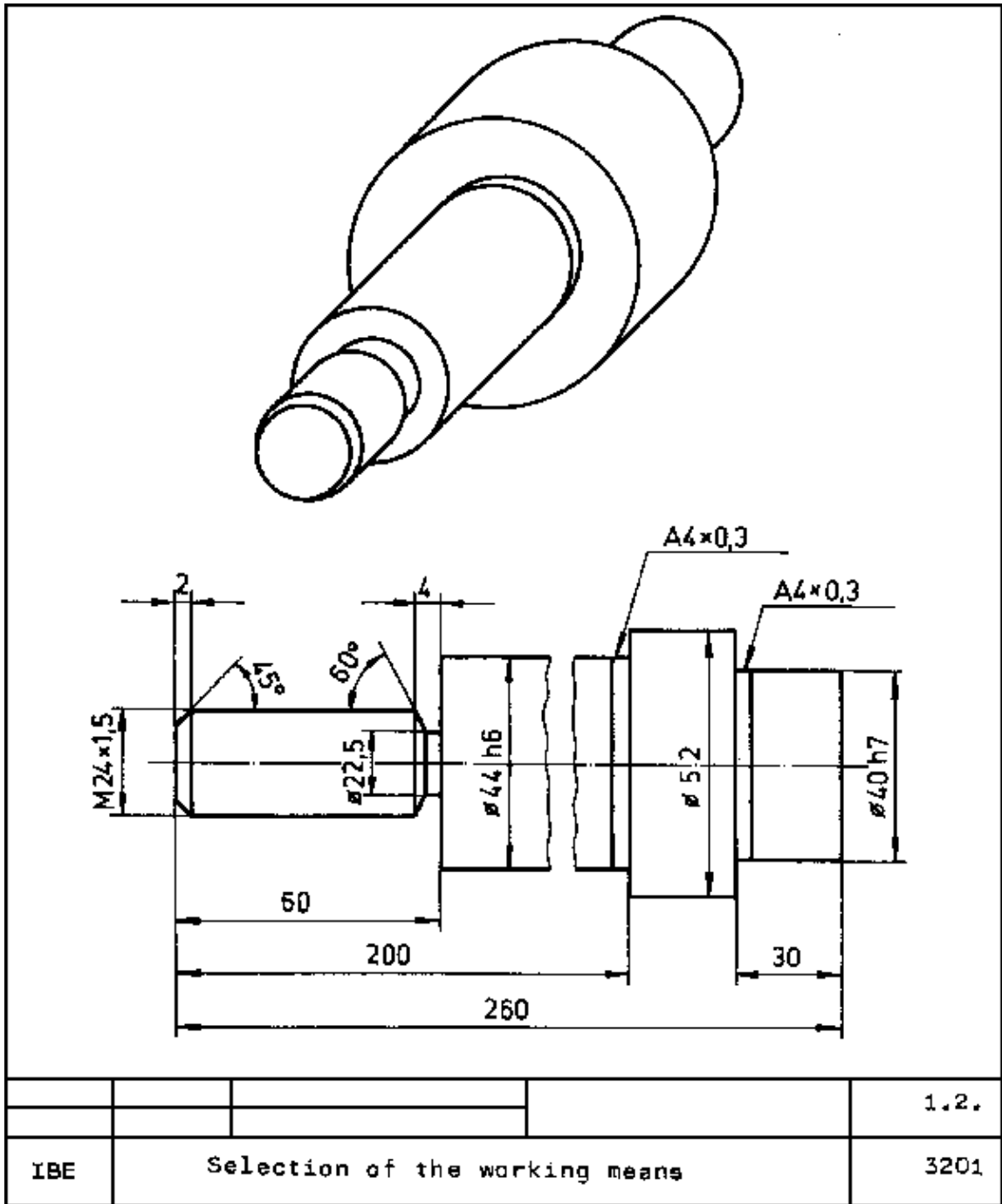

Selection of the working means

Instruction example 1.3.: Clamping and aligning of workpiece and tool

Material:

20 Mn Cr 5 low-alloy steel, 0.2 % carbon, 1.2 % manganese, less than 1 % chromium, rest: iron

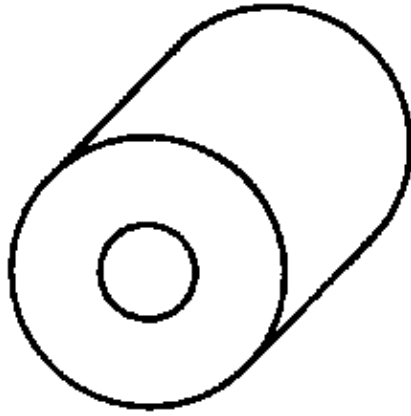

Tools

Auxiliary means

- | | |
|----------------------|---------------------------------|
| Internal corner tool | Gripping jaws that can be bored |
| Boring tool | Shims |
| Undercut ting-tool | Hollowing rings |
| Clamping wrench | |
| Open-end wrench | |

Measuring and testing tools

Vernier caliper

Dial gauge

Required previous knowledge

Kinds and application of clamping means and auxiliary means, reading of the technical drawing.

Explanations of the workshop drawing

- 36 h 6: 36 = Nominal diameter
 h = Basic shaft
 6 = Quality
- A4 x 0.3: A = Recess at the diameter
 4 = width of the recess in mm
 0.3 = Depth of the recess below final size

Sequence of operations

Remarks

- | | |
|---|--|
| 1. Putting in soft jaws. | Use of soft jaws in order to secure true running and to maintain the surface quality of the workpiece. |
| 2. Hollowing the soft jaws to Ø 60 mm and a depth of 50 mm. | Use the required hollowing rings. When clamping, mark the clamping spot on the chuck and use the same place in all following operations. |
| 3. Clamping the workpiece. | Pay attention to the clamping force – with too much force, the workpiece will be deformed. Use the marked clamping places. |

4. Aligning the workpiece. Control the true running with the help of the dial gauge at the external diameter.
5. Clamping the tool. With multi-tool holders, clamp one drilling tool for through holes and blind holes, each as well as one undercutting tool of 3 mm in width, with the help of shims (with round tool shank – prism).
6. Aligning the tool. Pay attention to central position, required hollow grinding and length of the clamped part of the tool.

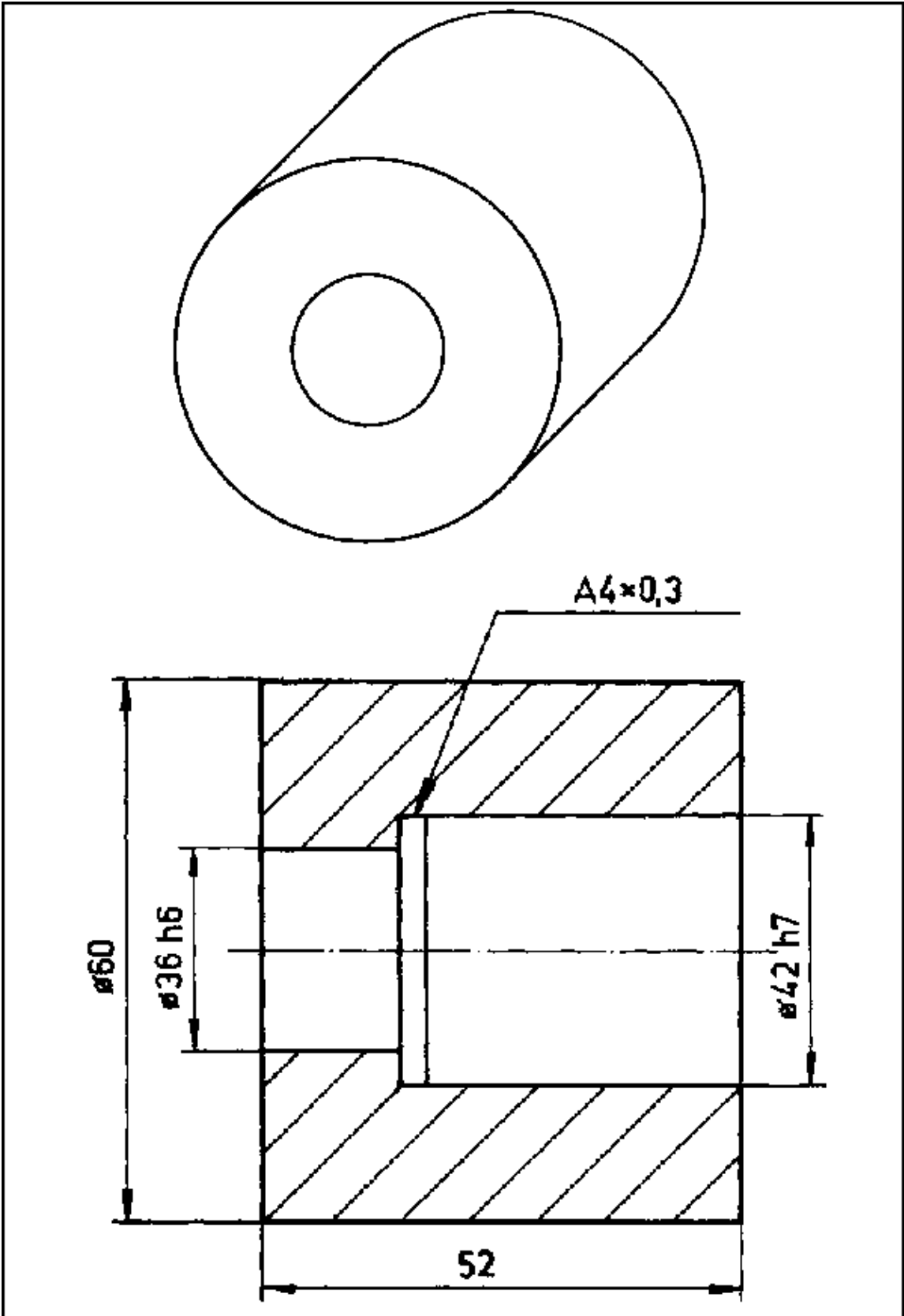

			1.3.
IBE	Clamping and aligning of workpiece and tool		3201

Clamping and aligning of workpiece and tool

Instruction example 1.4.: Care and maintenance of the lathe

Demonstrated by the example of a regular engine lathe.

Required previous knowledge

Qualities of lubricants and auxiliary agents, (lubricating schedule of the respective machine, operating instructions).

<u>Sequence of operations</u> <u>Kind of maintenance work</u>	<u>Remarks</u> <u>Frequency of maintenance work</u>
1. Cleaning of the guideway	Every day
2. Inspection of the oil level with the help of the oil-level gauge	Every day
3. Lubricating according to the lubrication schedule	Every day, every week, every three months, every six months
4. Cleaning the magnetic filter	Every three months
5. Draining off and replacing the oil	Every six months
6. Checking the contents of the coolant container	Every week
7. Cleaning the machine	Every week
8. Checking the bearing clearance	Every year
9. Checking contactors and limit switches	Every three months
10. Examining the lubrication pump	Every six months

The lubrication points of the lathe are given in the workshop sketch.

Permanent oil filling:	1
Oiling by the oil squirt:	2, 3, 6, 9, 10, 11, 12, 13, 14, 15
Oiling and cleaning of the sliding points:	4, 5, 7, 8

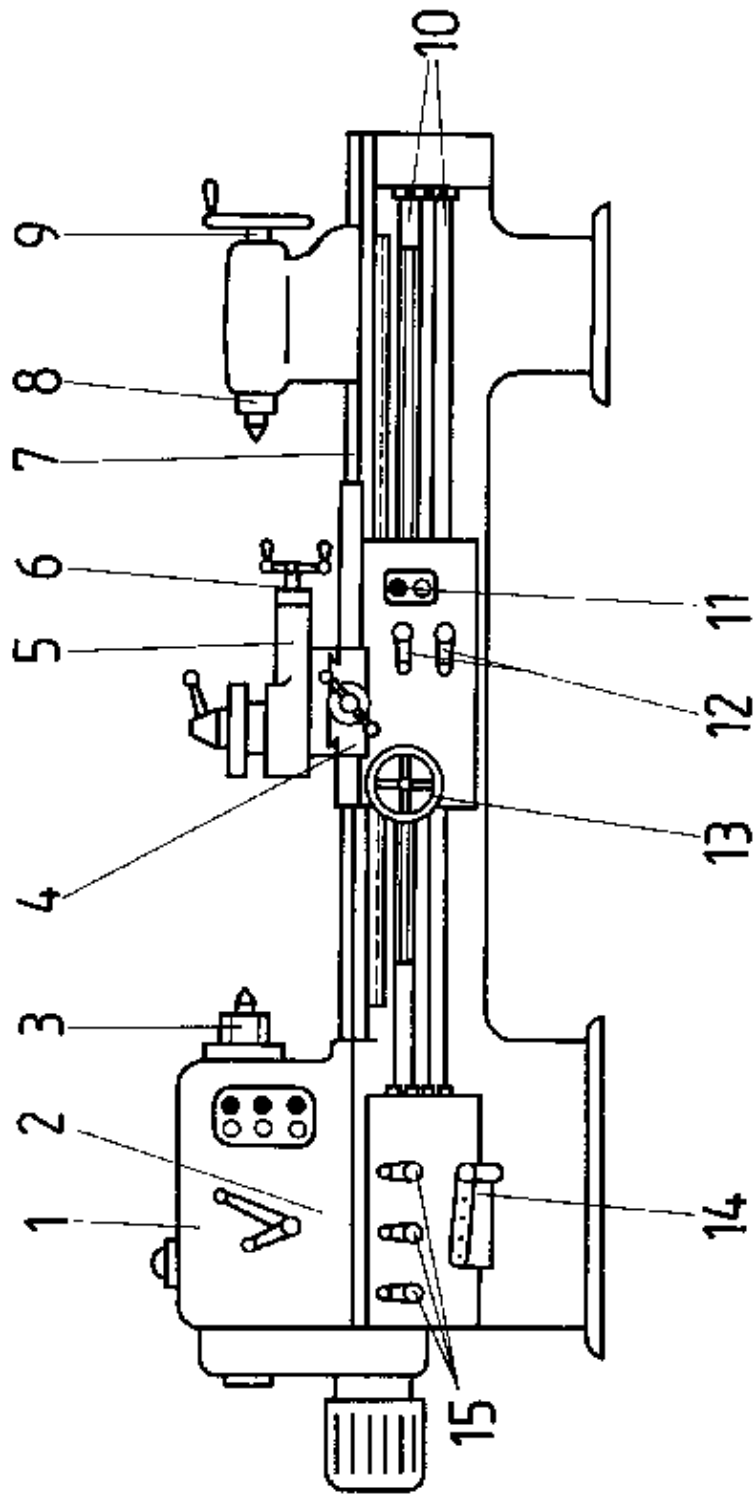

			1.4.
IBE	Care and maintenance of the lathe		3201

Care and maintenance of the lathe

**Setting-up and Operating of Regular Engine Lathes – Course:
Techniques for Machining of Material. Trainees' Handbook of Lessons**

Table of Contents

Setting-up and Operating of Regular Engine Lathes – Course: Techniques for Machining of

<u>Material. Trainees' Handbook of Lessons</u>	1
<u>1. Importance of the regular engine lathe</u>	1
<u>2. Structure of the regular engine lathe</u>	1
<u>3. Structure and types of lathe tools</u>	10
<u>4. Preparation of the work on the regular engine lathe</u>	17
<u>5. Setting-up and operating the regular engine lathe</u>	29
<u>6. Maintenance and care of the regular engine lathe</u>	33

Setting-up and Operating of Regular Engine Lathes – Course: Techniques for Machining of Material. Trainees' Handbook of Lessons

Institut für berufliche Entwicklung e.V.
Berlin

Original title:
Arbeitsmaterial für den Lernenden
“Einrichten und Bedienen von Leit- und Zugspindeldrehmaschinen”

Author: Horst Köth

First edition © IBE

Institut für berufliche Entwicklung e.V.
Parkstraße 23
13187 Berlin

Order No.: 90–35–3201/2

1. Importance of the regular engine lathe

The regular engine lathe is a machine tool which gives a workpiece the desired shape, dimensions and surface quality by chip removal. Creating a movement between tool and workpiece, it places the tool on the point from which the chip has to be removed. The chip removal is carried out mainly by single-edged, permanently acting tools and serves to manufacture rotationally symmetrical workpieces required for high-standard machines and plants.

By the regular engine lathe work can be carried out such as:

- Centring by centring drill or single-point boring tool
- Plane turning
- Surfacing
- Boring by twist drill or single-point boring tool
- Counterboring
- Reaming
- Recessing, cutting-out and parting-off
- Thread cutting by die, tap, etc., lathe tool (internal and external)
- Form turning
- Knurling and knurling straight-lined patterns

with the aim to manufacture workpieces true to size and of the required shape and surface quality.

Primary materials for turning are products of the rolling industry, forgings, pressed parts and castings.

2. Structure of the regular engine lathe

What main parts does a leadscrew and feed shaft lathe consist of?

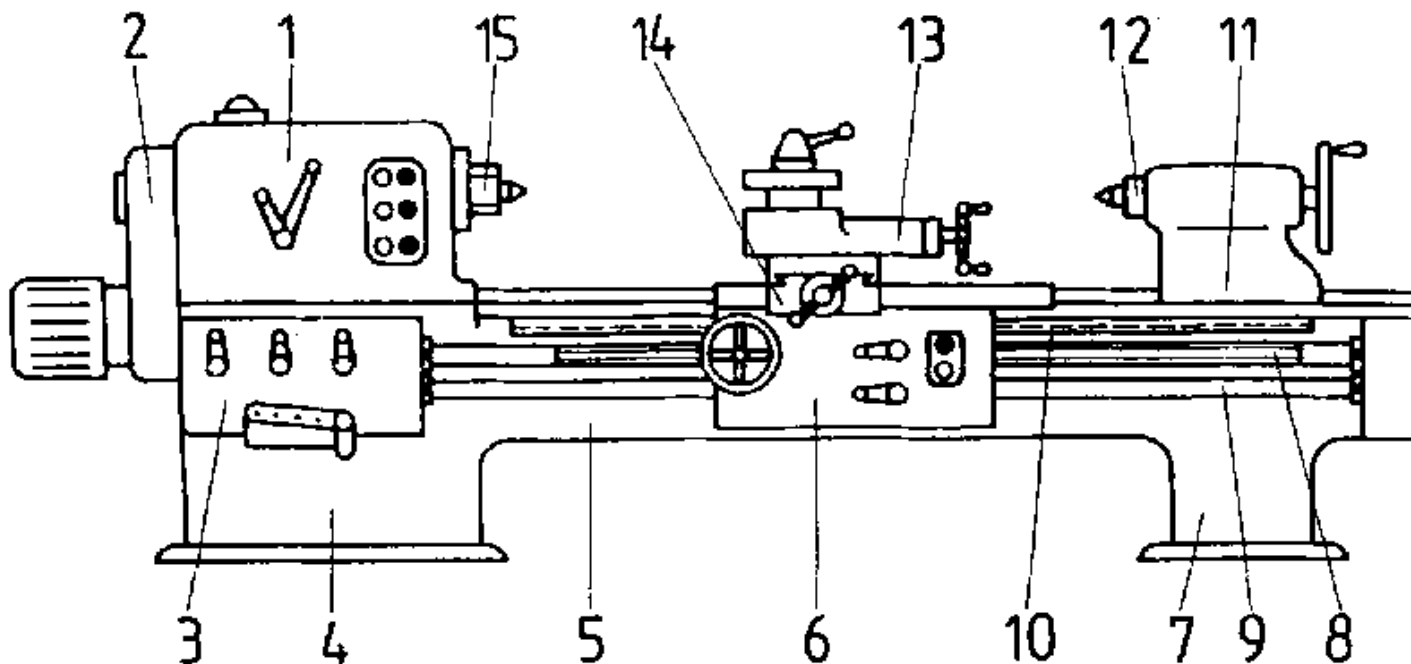

Figure 1. Regular engine lathe

1. _____

2. Train of pulleys

3. Feeding mechanism

4. _____

5. _____

6. _____

7. _____

8. _____

9. _____

10. _____

11. _____

12. Quill

13. _____

14. _____

15. Work-driving spindle

Regular engine lathes consist of various components which have to fulfill specific tasks, and the accurate functioning of which is a precondition of the handling of the operating elements.

The following components are distinguished:

- Lathe bed
- Gear box

- Apron
- Tailstock
- Leadscrew and feed shaft lathe

The faultless cooperation of the individual components and the correct operation of the lathe lead to the manufacture of workpieces of a high standard and the required accuracy.

Lathe bed

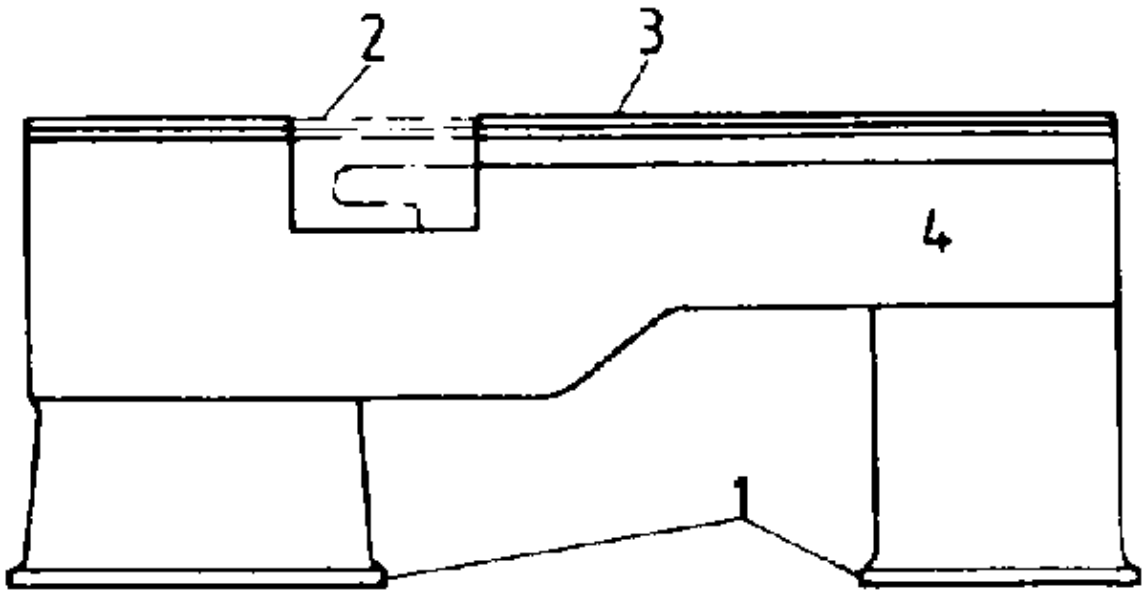

Figure 2. Lathe bed

1 lathe feet, 2 bridge, 3 guideways, 4 lathe bed

The lathe bed carries the spindle box with the work-driving spindle and the main driving mechanism, the carriage with apron, saddle, cross slide, tool rest and lathe tool holder as well as tailstock with quill.

The apron and the tailstock are movable and are led on the lathe bed. In order to avoid shocks and vibrations as far as possible, the lathe bed is of a rigid construction.

Mostly, grey cast iron is used as material for the lathe bed, because this material absorbs shocks and vibrations and the graphite components create good sliding qualities and keep the abrasion low. To enable the turning of larger workpieces, the swing diameters of which are greater than their nominal diameters, on the faceplate, some lathes are equipped with a bridge that can be removed.

Important parts of the lathe bed are the guideways, of which two basic kinds are distinguished – sliding and roller guideways.

The sliding guideways are characterized by simple manufacture, great strength and faultless localization of the groups to be led. Roller guideways have roll bodies, only little friction, but are complicated in manufacture, have a low stressability and, when worn, become useless due to backlash.

Therefore, sliding guideways are used preferably.

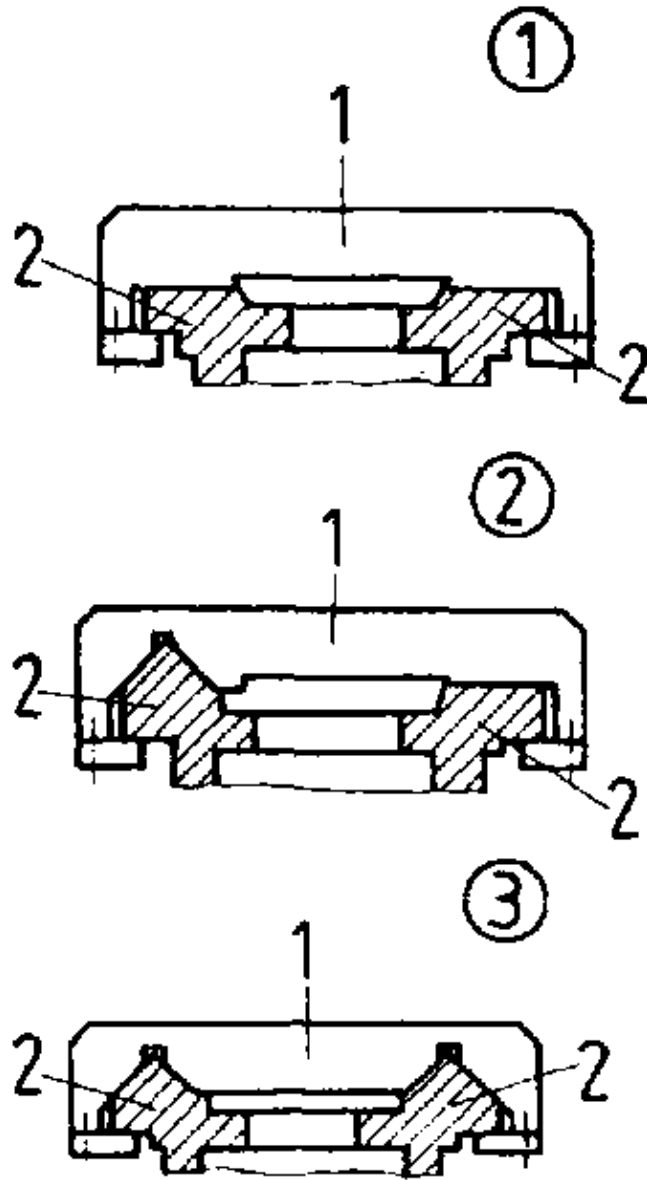

Figure 3. Slide

① flat track, ② combination of roof guide and flat track, ③ double roof guide
 1 saddle, 2 slide of the lathe bed

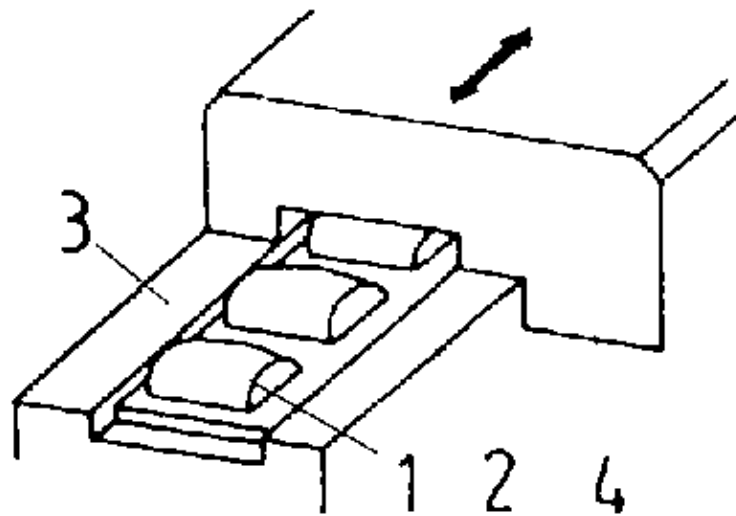

Figure 4. Roller guide

1 roll body, 2 cage, 3 lathe bed, 4 saddle

Why do some regular engine lathes have a bridge in the lathe bed and what purpose does it serve?

What are advantages and disadvantages of sliding and roller guideways, respectively, and which kind of guideways is used preferably?

Gear box

The main parts of the gear box are the headstock with the work-driving spindle, the main driving mechanism with the drive shaft as well as the feeding mechanism and the change-gear train.

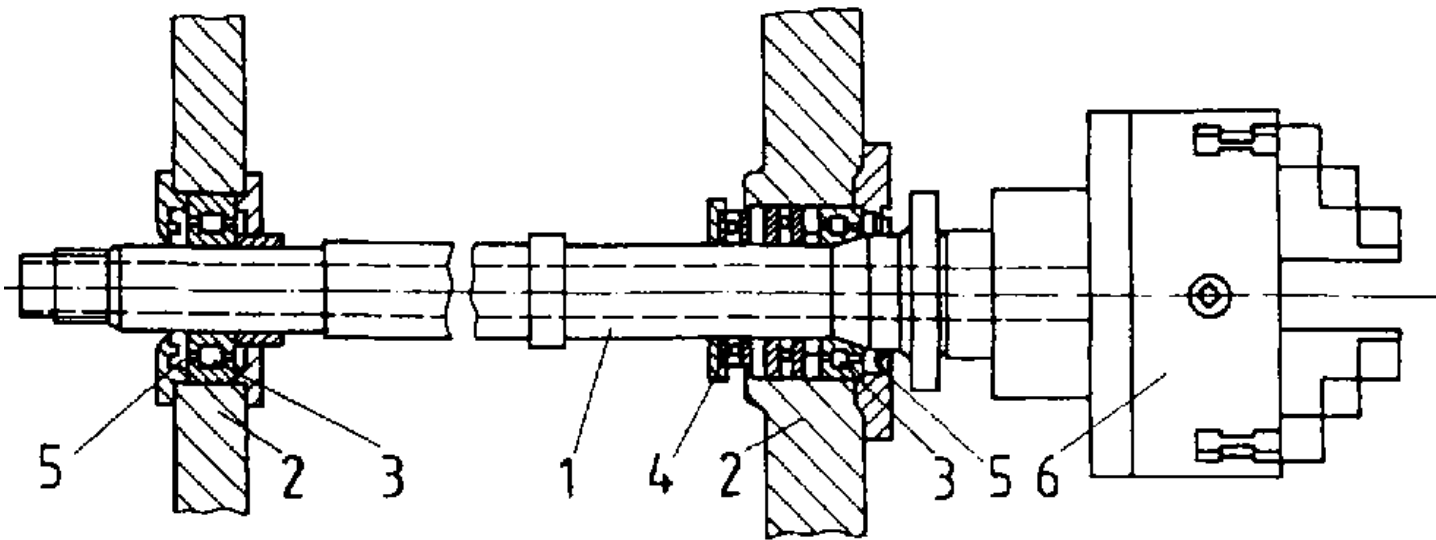

Figure 5. Work-driving spindle

1 work-driving spindle, 2 headstock casing, 3 radial roller bearing, 4 journal ball bearing, 5 packing, 6 chuck

In the headstock, the work-driving spindle is accommodated.

Mostly, the work-driving spindle is a hollow shaft, so that the material can be fed in, if required, (e.g. bar stock for the mass production of screws).

The end is equipped with an internal taper for receiving a centre and with an external thread for fixing the turning chuck, the faceplate, the work driver, etc. For radial stress, mostly cylindrical roller bearings, are used, for axial stress journal ball bearings.

The rotational speed of the spindle required for each respective operation is switched via the main driving mechanism. The main driving mechanism is designed either as a change-speed drive or as a stepless drive.

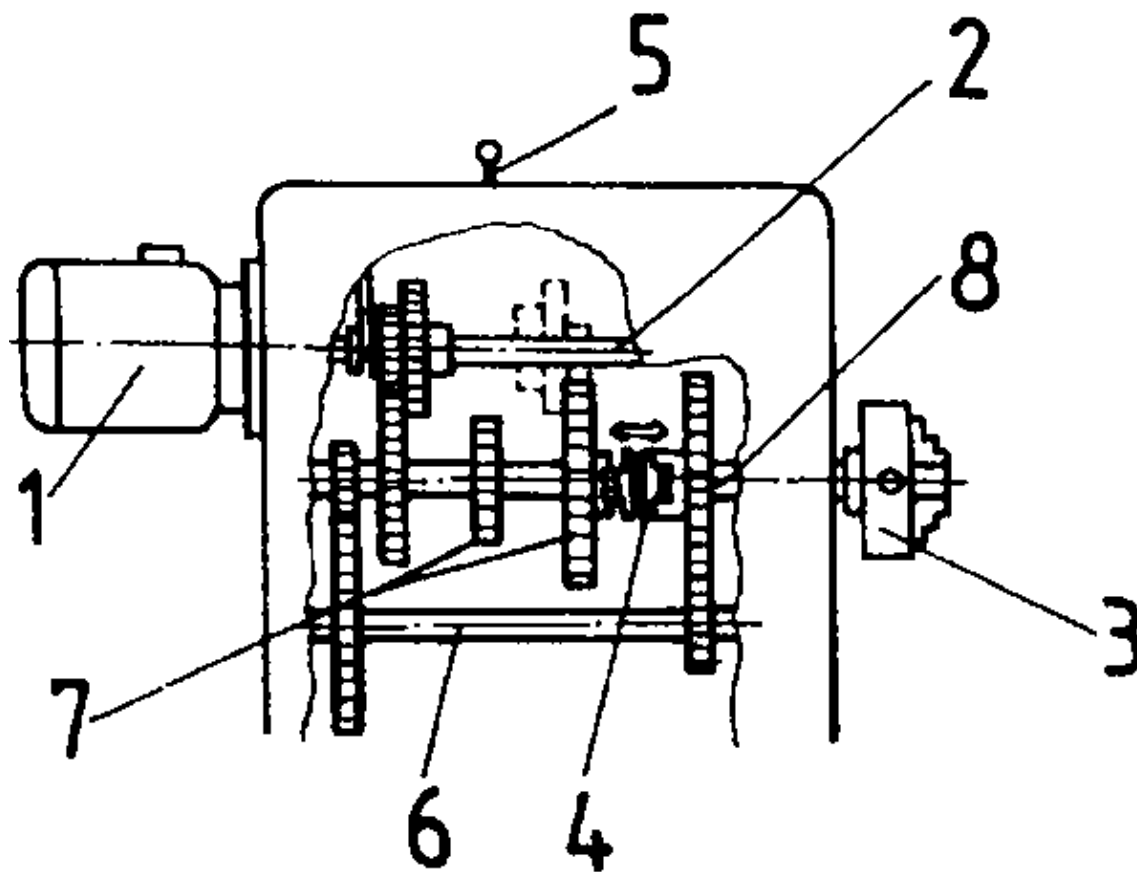

Figure 6. Main driving mechanism

1 driving motor (flange-mounted motor), 2 main shaft, 3 chuck, 4 coupling, 5 operating lever, 6 countershaft, 7 gears, 8 work-driving spindle

The power is transmitted from the motor via the toothed gears or the belt drive to the work-driving spindle (workpiece) or the feeding mechanism, respectively.

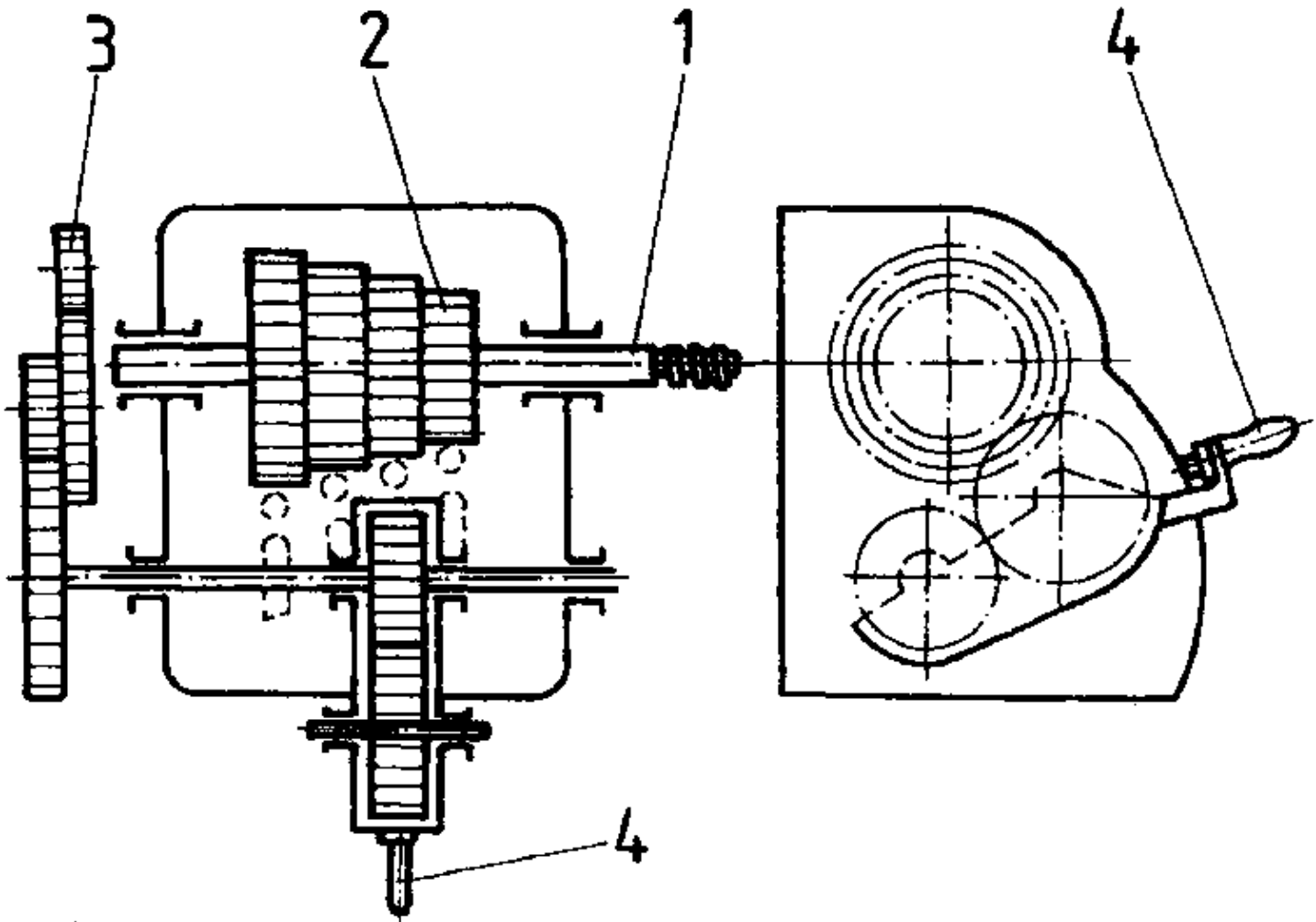

Figure 7. Feeding mechanism and change gear mechanism

1 leadscrew, 2 toothed gears, 3 change gear mechanism, 4 switching lever

By the feeding mechanism and the change-gear train the stepped feeding speeds are set, the thread cutting with different pitches is enabled, and the leadscrew and/or feed shaft is driven.

What are the tasks of the feeding mechanism?

Describe the power train at a regular engine lathe.

1. _____
2. _____
3. _____
4. _____
5. _____

Carriage

On the carriage, the tools are fixed, put in working position and guided. The carriage slides on two prisms; it consists of the saddle, cross slide, swivel, tool rest and lathe tool holder.

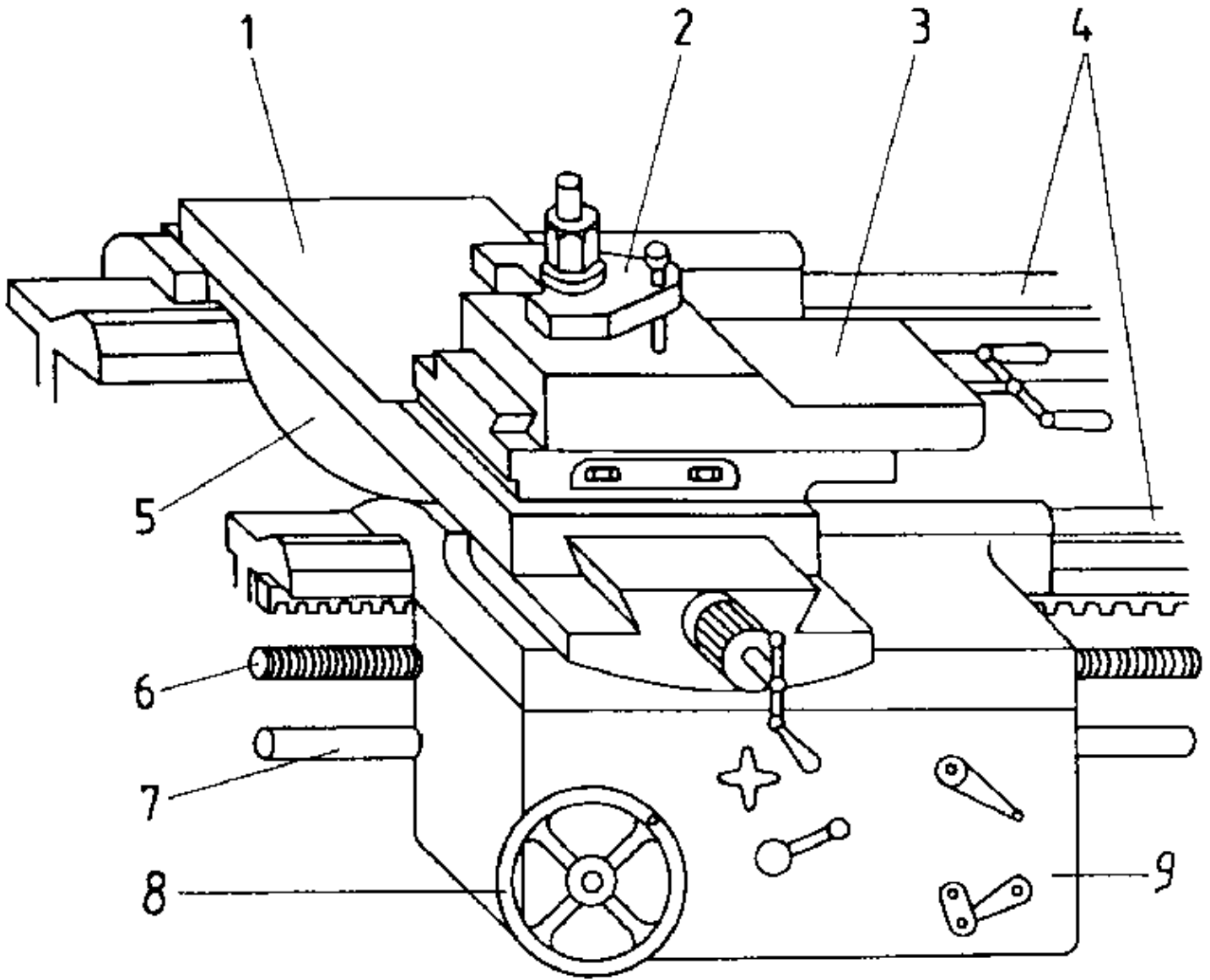

Figure 8. Carriage

1 cross slide, 2 lathe tool, holder, 3 tool rest, 4 guideways, 5 carriage, 6 leadscrew, 7 feed shaft, 8 hand wheel for longitudinal feed, 9 apron

The tool rest is pivoted on the cross slide and has a graduation in degrees for adjustment and/or taper turning. The compound rests slide in adjustable, dovetailed prismatic guideways.

The downfeed screws have ball cranks and large graduated disks for adjustment. The lathe tools are clamped in single or multiple-tool holders. The carriage is bolted to the lathe apron, which – due to its way of acting – belongs to the feed drive.

What are the tasks the carriage has to fulfill?

Tailstock

The tailstock is used as a counter-holding device for turning long workpieces or for drilling,

The tailstock is sliding on the guideways of the lathe bed and can be fixed in any place.

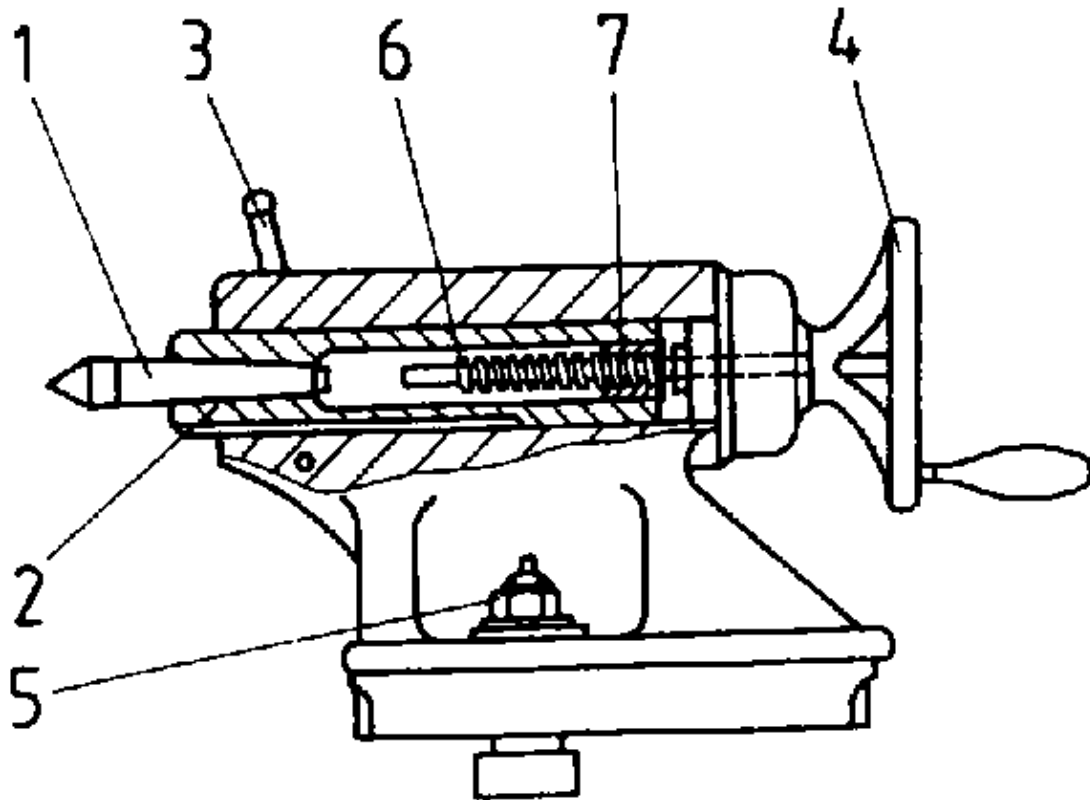

Figure 9. Tailstock

1 tailstock centre (replaceable), 2 quill, 3 clamping lever of the clamping nut, 4 hand wheel 5 tailstock clamping nut, 6 spindle, 7 spindle nut

When turning cylindrical workpieces, the centres of the headstock and of the tailstock must be exactly in line. By transverse displacement, it may also be used for turning slender tapers (loosening of the bridge, displacement of the tailstock on the bed plate by screws).

The quill is guided in a longitudinal boring. Its internal taper receives the centre of the tailstock, the drill, the drill chuck or the reamer. The quill can be moved in its longitudinal direction for clamping the workpiece or for the drill feed. This can be made mechanically – through spindle and hand wheel or by levers – as well as hydraulically or pneumatically. By a clamping device the quill can be fixed in any position.

How can tapers be manufactured with the help of the tailstock and how must the tailstock be aligned for turning cylindrical workpieces?

Leadscrew and feed shaft

The leadscrew and feed shaft serve the purpose of thread cutting and/or automatic longitudinal and cross feed. The leadscrew is recognized by its acme thread, the feed shaft by its cylindrical shaft with longitudinal groove.

The power transmission of the leadscrew with thread cutting is effected by the closing of split nuts via toothed gears on the gear rack and from there on the carriage.

The feed is effected by the feed shaft the power being transmitted to the gear rack via a worm and toothed gears.

Describe the power train from the leadscrew and feed shaft to the carriage.

3. Structure and types of lathe tools

Knowledge of the lathe tools, their forms and application is the precondition of efficient working.

Structure of the lathe tool

Every lathe tool consists of the shank and the tool point. At the tool point, there are the top face and the flank. Shank and tool point may be made of the same material forming a whole.

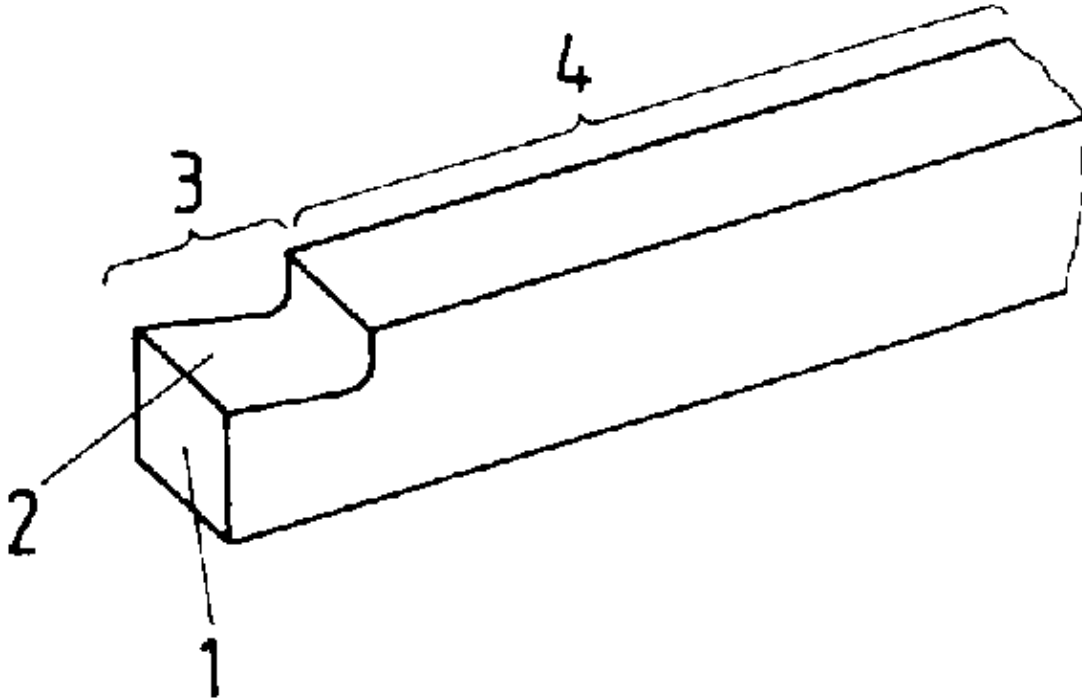

Figure 10. Structure of the lathe tool

1 flank, 2 cutting face, 3 tool point, 4 shank

In order to save valuable cutting material (high-speed steel) or because it is required by the qualities of other cutting materials such as hard metal, ceramic cutting materials, diamonds, the shank is often made from mild steel.

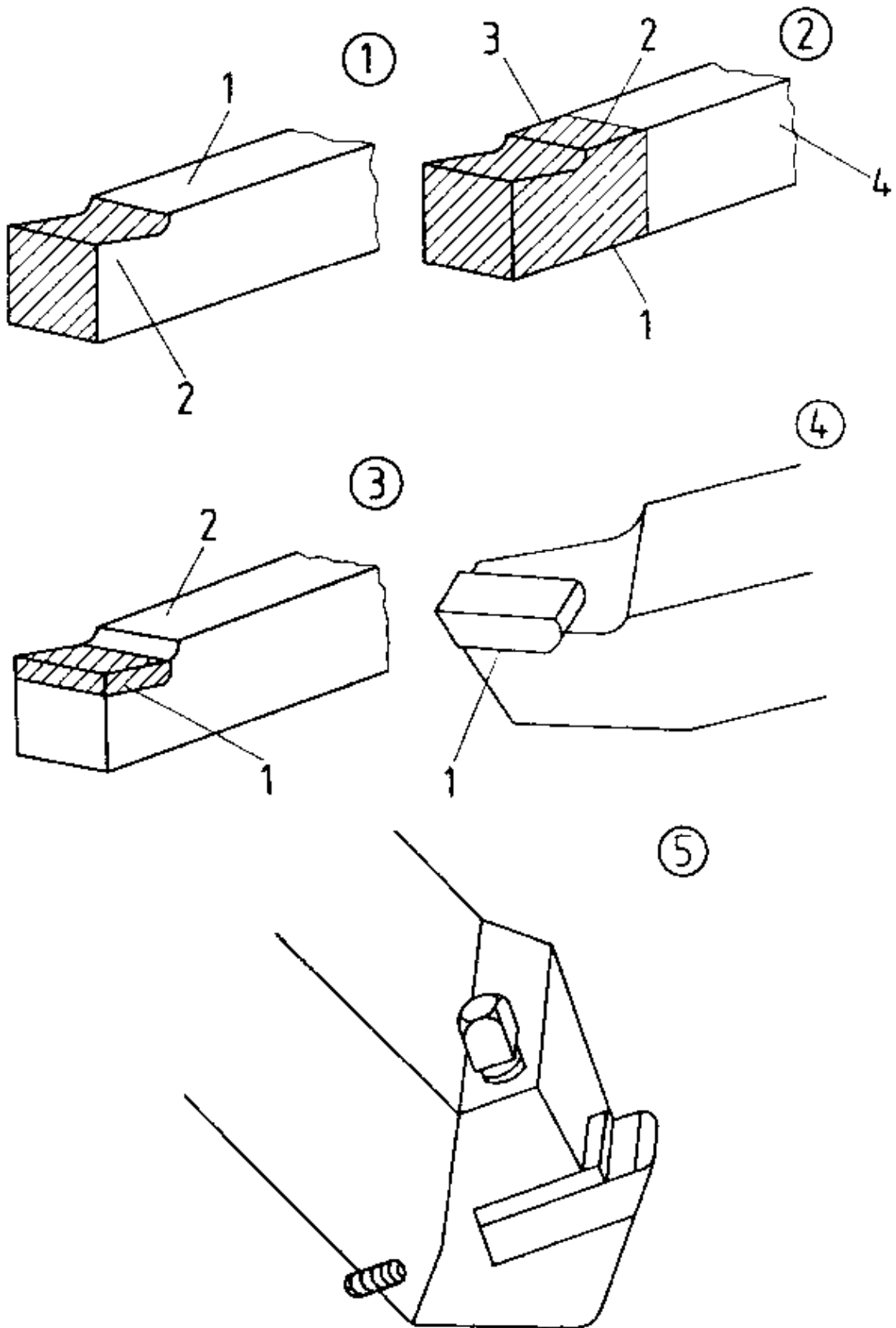

Figure 11. Lathe tool shank and cutting edge from solid steel or different materials

① lathe tool from solid steel
1 shank, 2 cutting head

② welded on (butt welded)
1 hardness threshold, 2 welding point, 3 high-speed steel, 4 mild steel

③ welded on

1 high-speed steel, 2 mild steel

④ welded on

1 soldering seam

⑤ seized

The cutting tip is welded or soldered or clamped in place in the form of a plate. The flank of the lathe tool is the surface of the tool point which is directed against the area of cut at the workpiece. The top face is the surface of the tool point over which the chip is removed.

Top face and flank must always be well and smoothly ground, so that no additional heat is created by friction during the turning process and a long service life of the tool is achieved.

Cutting edges at the lathe tool

The lathe tool has a primary cutting edge and a secondary cutting edge. The primary cutting edge faces the feed direction. The secondary cutting edge is adjacent to the primary cutting edge.

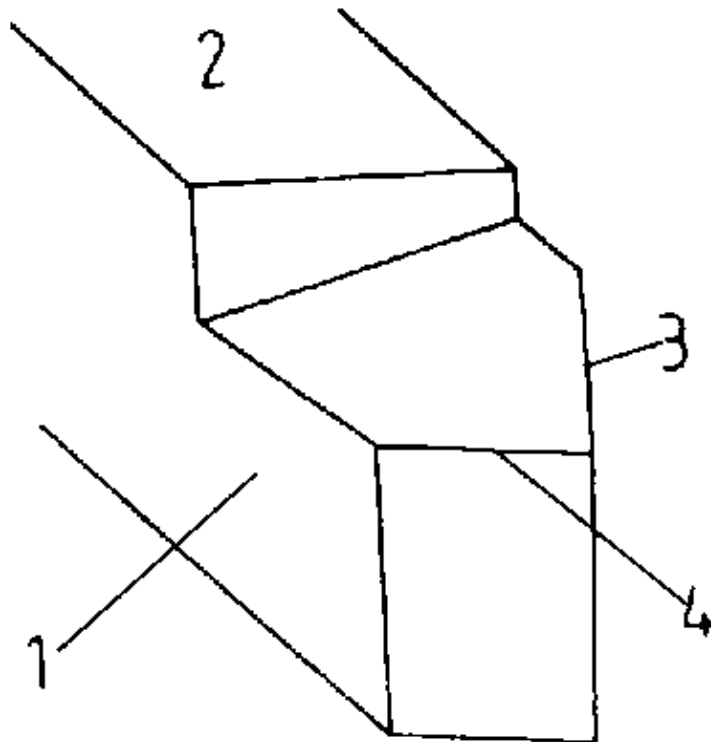

Figure 12. Cutting edges at the lathe tool

1 tool point, 2 shank, 3 main cutting edge 4 secondary cutting edge

Describe the structure of the lathe tools.

Angles at the lathe tool

Only if the cutting edges are ground correctly, the lathe tools can work economically. Therefore, one must know the correct angles at the cutting edge. The form of the cutting edge of the lathe tool is determined by the following angles:

? = angle of clearance

? = cutting-wedge angle

ϕ = rake angle
 θ = cutting angle ($\phi + \theta$)

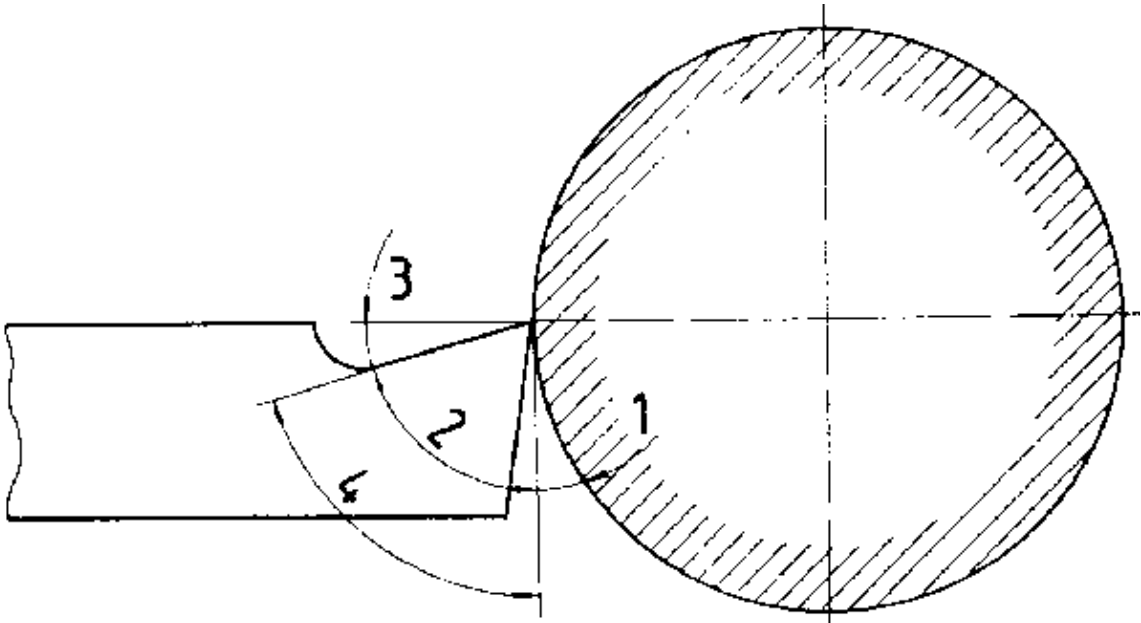

Figure 13. Angles at the lathe tool

1 angle of clearance θ , 2 rake angle ϕ , 3 cutting-wedge angle θ , 4 cutting angle θ

– The cutting-wedge angle θ is situated between flank and cutting face. It is measured in the normal (vertical) to the cutting edge. Its size is determined by the strength of the material to be worked.

Hard materials require a large cutting-wedge angle, for instance steel: $\theta = 60 - 75^\circ$; soft materials require a small cutting-wedge angle, for instance aluminium: $\theta = 40^\circ$.

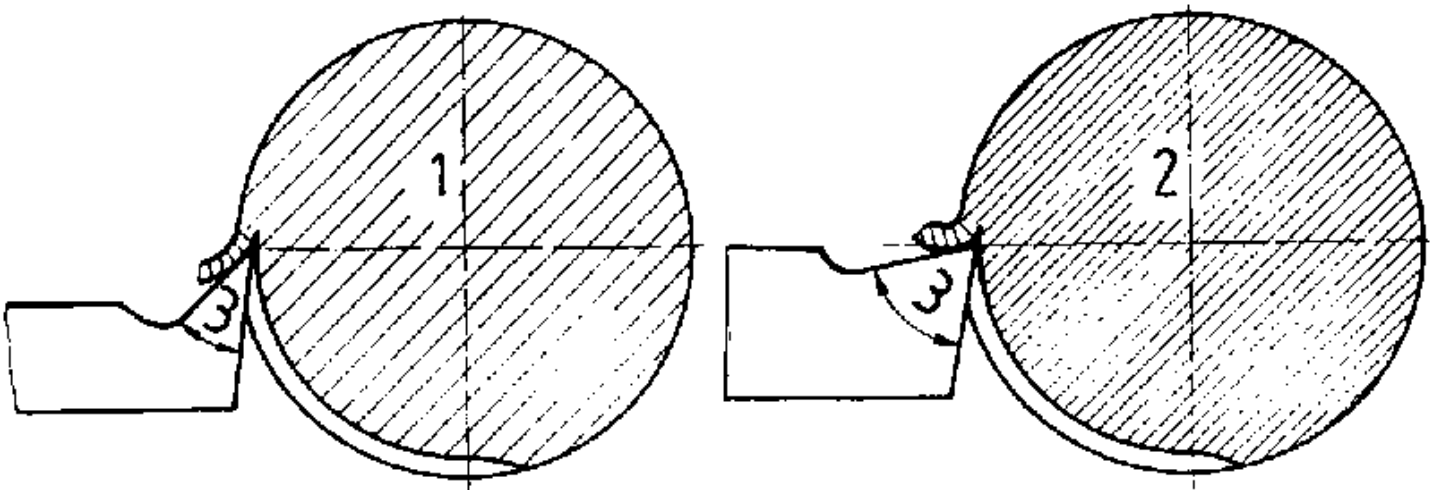

Figure 14. Lathe tool with small or large cutting-wedge angle

1 soft material – small cutting-wedge angle, 2 hard material – large cutting-wedge angle, 3 cutting-wedge angle θ

– The angle of clearance θ is determined by the flank and the tangent running through the points of contact of the cutting edge with the circumferential surface of the workpiece.

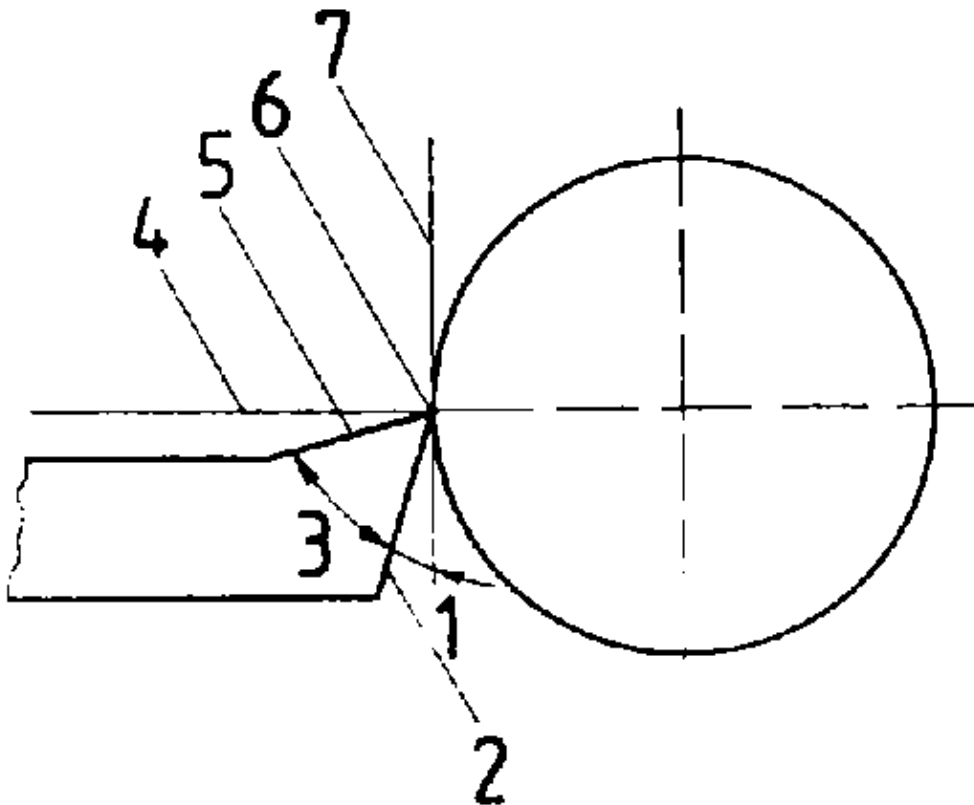

Figure 15. Position of the angle of clearance

1 angle of clearance ϕ , 2 flank, 3 cutting-wedge angle α , 4 vertical, 5 top face, 6 point of contact, 7 tangent

The angle of clearance must always be chosen only that large so that there is not too much friction between tool and work-piece.

– The rake angle γ is formed by the cutting face and the vertical drawn on the tangent in the point of contact. In principle, the rake angle should be kept large in order to enable an easy removal of the chips. However, the size of the rake angle is limited by the size of the cutting-wedge angle which depends on the material.

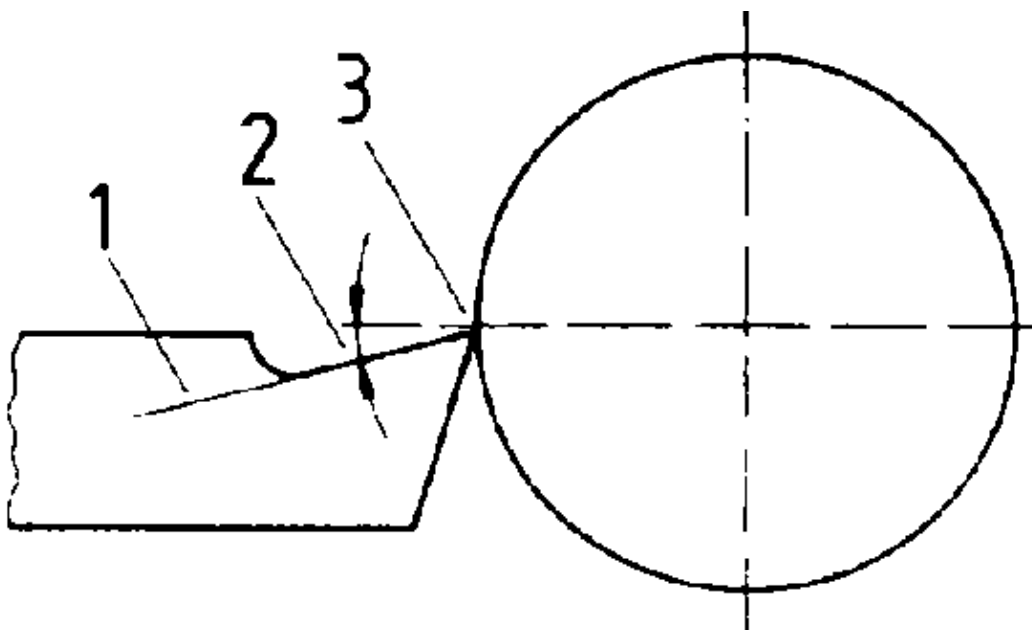

Figure 16. Position of the rake angle

1 top face, 2 rake angle γ , 3 vertical

– The cutting angle ϕ plays a secondary part only.

It is formed by the angle for clearance and the cutting–wedge angle ($\phi = \alpha + \beta$). It is situated between the cutting face and the vertical plane to the cutting edge.

Table 1 gives a general survey of the sizes of the angles at the lathe tool related to the cutting material “high–speed steel”.

Why is it necessary to know the correct angles at the cutting edge of the tool?

Table 1

Material to be worked	Angle of clearance	Cutting–wedge angle	Rake angle ¹⁾
	(indication of angles in °)		
Steel	8	62 – 68	14 – 20
Alloyed steel	8	68 – 74	8 – 14
Tool steel	8	72	10
Grey cast iron	8	80	2
Copper	10	55	25
Brass	8	74	8
Bronze	8	74	8
Aluminium	10	60	20

¹⁾ The angles apply to rigid cutting conditions. In semi–rigid conditions, only the rake angle has to be increased up to 15 %, with unstable conditions up to 25 % and with soft, smearing materials up to 30 % in order to achieve a good non–torn finish–machined surface.

Types of lathe tools:

The type of lathe tool to be used in each respective case is determined by the shape of the workpiece which has to be worked.

For longitudinal turning, roughing and finishing lathe tools are required, for turning internal surfaces such as corners side cutting turning tools, for plunging and cutting–off parting–off tools etc.

If much material has to be removed, the roughing tool has to be used first. If high demands are made on the surface quality of the workpiece, the finishing lathe tool has to be used. Each operation requires the corresponding lathe tool. It would be a waste of time and expensive material to permanently adapt one lathe tool – for instance a side cutting turning tool for all sorts of turning.

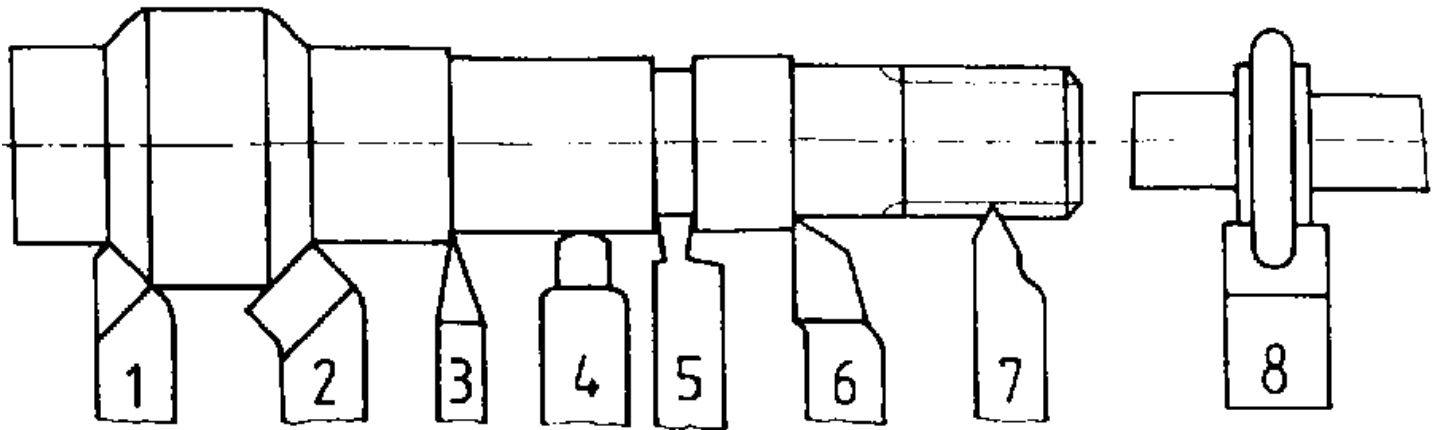

Figure 17. Tools for turning external diameters

1 straight left roughing lathe tool, 2 bent right roughing lathe tool, 3 straight finishing tool, 4 broad finishing tool, 5 straight right-end-cut turning tool, 6 offset side cutting turning tool, 7 vee thread cutting tool, 8 form turning tool

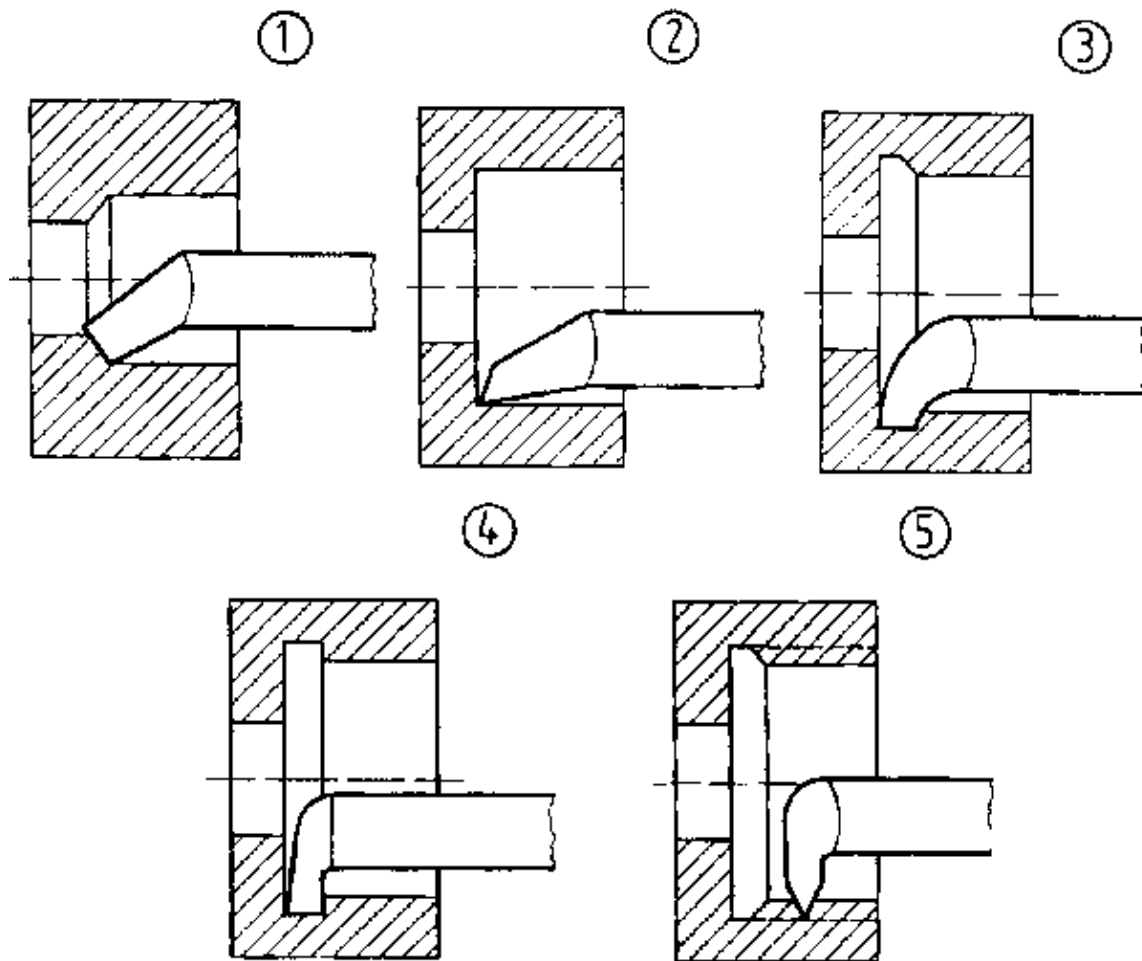

Figure 18. Internal turning tools

① single-point boring tool; ② internal side cutting turning tool; ③ thread groove plunging tool; ④ right undercutting tool; ⑤ internal screw-cutting tool

The most important lathe tools are standardized as to their shapes and dimensions. As far as the designations of the angles and surfaces as well as of the various types of lathe tools are concerned, there are generally valid international arrangements, too.

Lathe tools for turning internal and external surfaces are generally distinguished as shown in the pictures. What does the use of the respective types of lathe tools depend on?

4. Preparation of the work on the regular engine lathe

Possibilities of tool clamping

Lathe tools must be firm and safely clamped. Insufficient clamping may lead to rejects or accidents. By the clamping claw or the lathe tool holder, the lathe tool is fixed well even with difficult cuts.

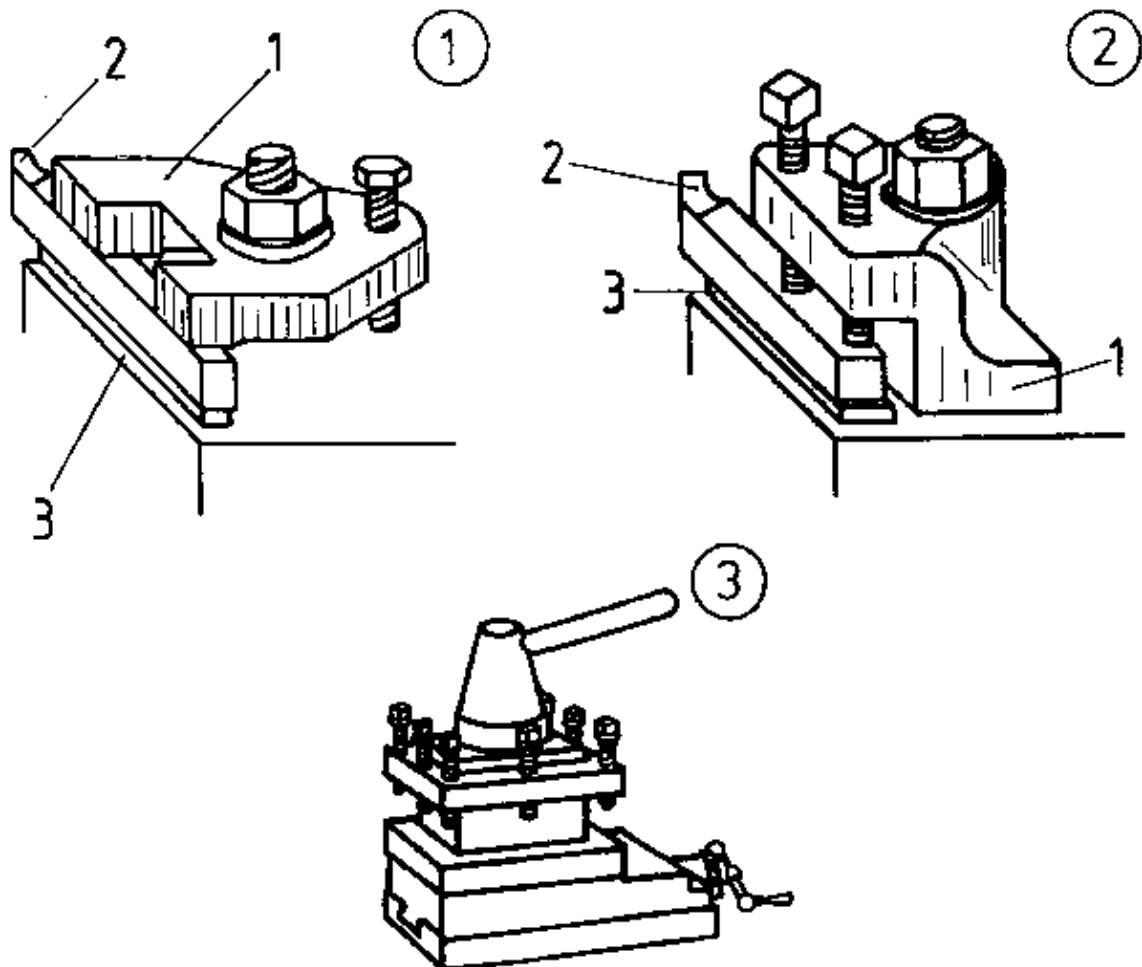

Figure 19. Clamping possibilities of the lathe tool

- ① clamping jaw; ② lathe tool holder; ③ rotatable fourfold lathe tool holder

With the help of the quadruple lathe tool holder, up to four lathe tools can be set up for the respective work.

Thus, the clamping and unclamping of the lathe tools and the work-pieces for the individual operations is no more necessary. As soon as a new workpiece shall be worked, the hand lever is unlocked, the tool holder is turned and the lever is tightened again with the exact position of the individual lathe tools being secured by an index.

Clamping must be firm and safe. Insufficient clamping may cause rejects, breaking of the lathe tools and accidents.

Pay attention to the following points:

- The lathe tool must always be in dead central position (centre of the tailstock/setting gauge).
- Height adjustment by sheet metal backings (must be accurately plane and clean; use a few thick backings instead of many thin ones; the length should be at least three quarters of that of the tool shank).
- Do not adjust the height by placing sheet metal under the rear end of the lathe tool.
- Use of the quadruple lathe tool holder.

The multiple-cutting edge boring tools are put by their taper shank into the machine taper of the tailstock spindle.

Then, they are advanced towards the workpiece which is rotating with the work-driving spindle with the help of the hand wheel.

If the external taper of the drill and the internal taper of the quill do not match, the difference – if the internal taper is larger – can be balanced by reducing sleeves.

External and internal tapers must be absolutely clean, otherwise the drill rotates in the quill and destroys the internal taper.

In addition, it would, in such case, not be at centre with the rotation axis.

Larger drills are protected against the above mentioned kind of rotation by putting on a work driver.

Small drills are clamped in the drill chuck, which, then, is put into the quill by its taper shank.

In some cases, the automatic feed is used for moving the boring tool forward. For this purpose, the drill is clamped on the carriage with the help of a holding device.

Drill axis and rotation axis must be accurately congruent.

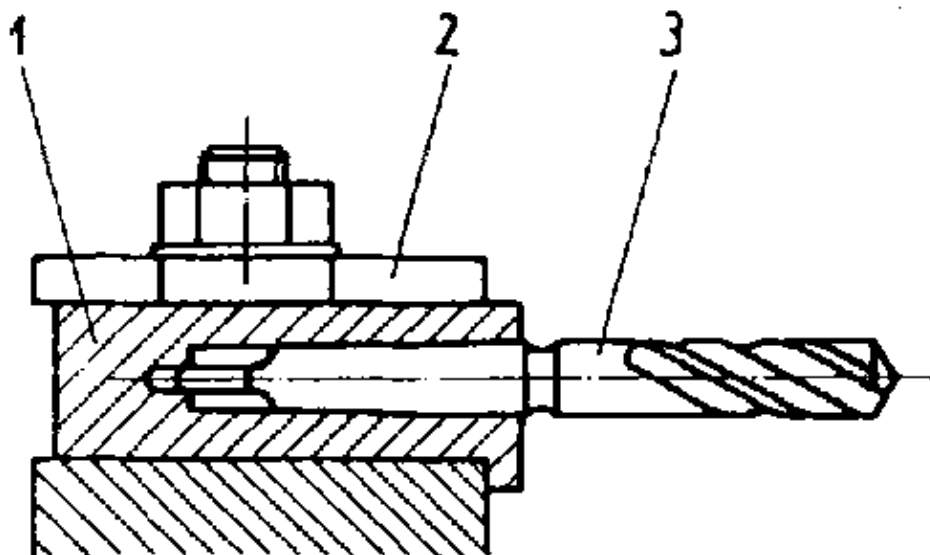

Figure 20. Boring block

1 boring block, 2 lathe tool holder, 3 twist drill

Possibilities of clamping the workpieces

The three-jaw chuck serves for clamping short workpieces quickly, safely and centrally.

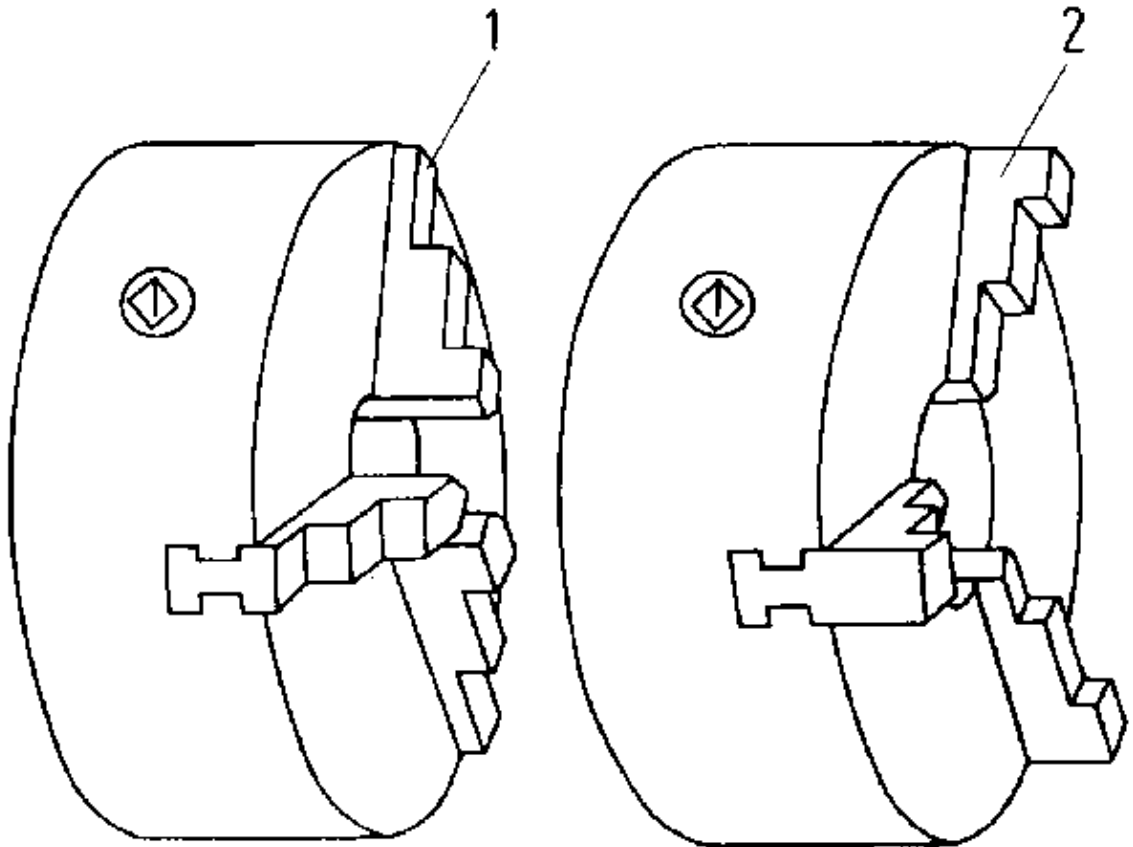

Figure 21. Three-jaw chuck

1 three-jaw chuck with turning jaws, 2 three-jaw chuck with boring jaws

With the help of the four-jaw chuck, quadrangular and octagonal parts are clamped.

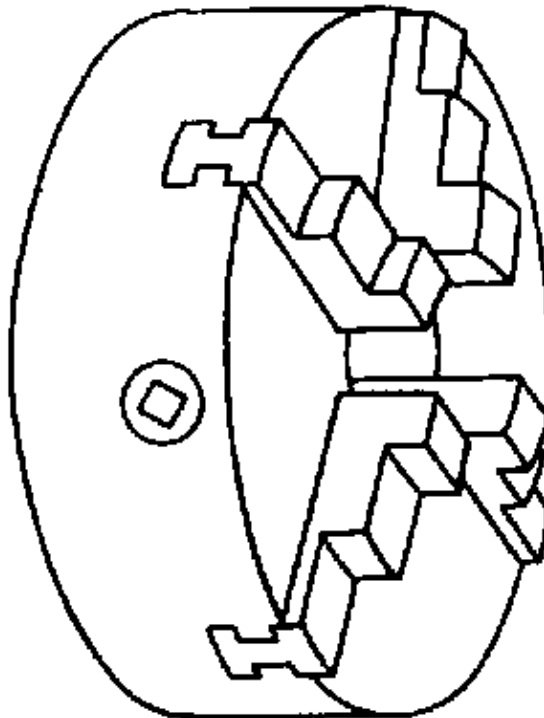

Figure 22. Four-jaw chuck

In order to achieve an exact true running of the parts, soft gripping jaws are used which are bored true to size of the respective workpieces.

Small, irregularly shaped workpieces are often clamped in the four-jaw chuck with individually adjustable chuck jaws.

They can be quickly aligned. The chuck jaws can be moved in common as well as individually,

For clamping smaller workpieces and for working from the bar, especially on turret lathes and automatics, the collet chuck is used.

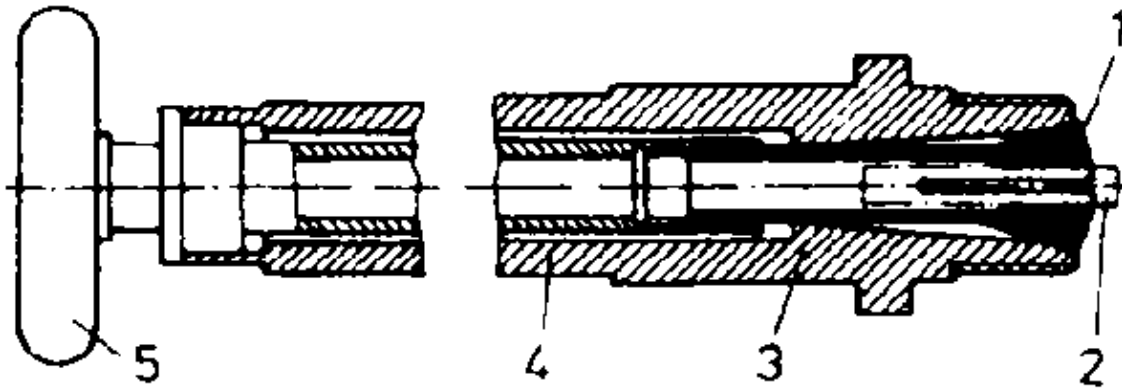

Figure 23. Collet

1 clamping body, 2 workpiece, 3 lathe spindle, 4 clamping tube, 5 handwheel

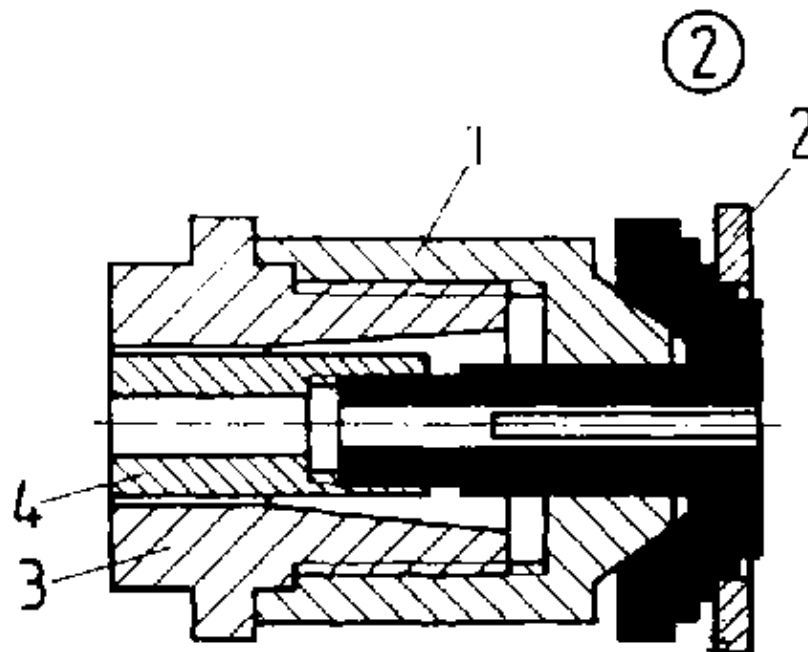
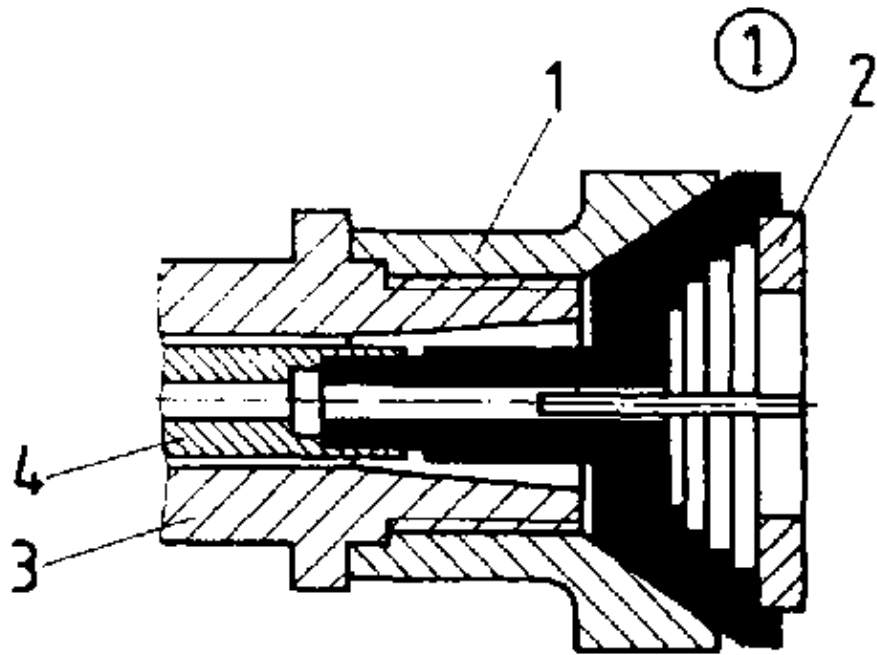

Figure 24. Step chuck

① internal step chuck; ② external step chuck
 1 basic chuck, 2 workpiece, 3 lathe spindle, 4 clamping tube

Large, flat bodies of revolution such as disks and lids but also square and rectangular as well as irregularly shaped workpieces are – nearly without exception – are clamped flying on faceplates.

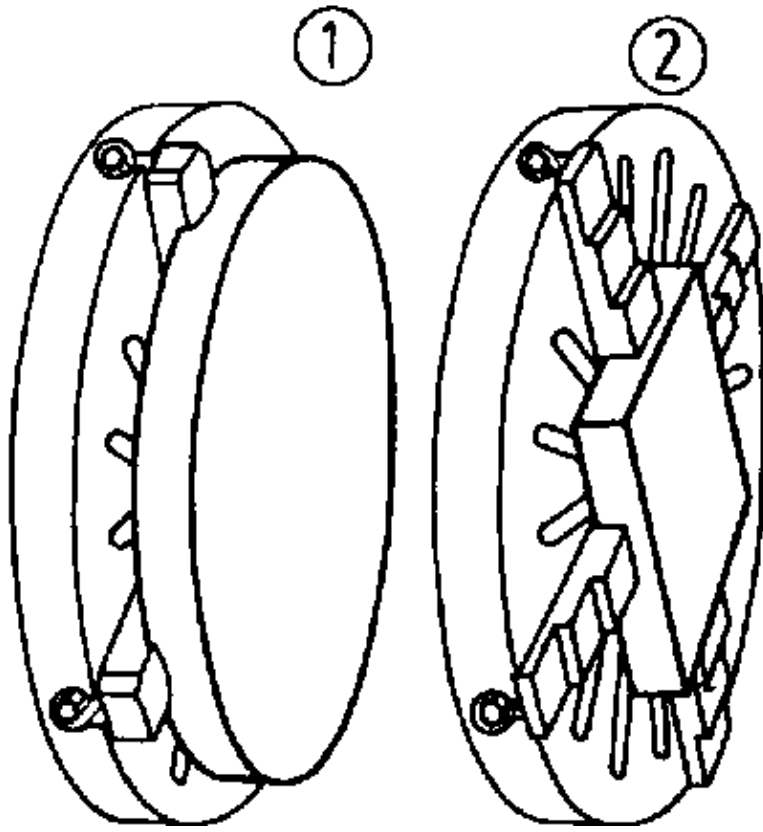

Figure 25. Faceplate

- ① clamping of large disks
- ② clamping of square workpieces

A very economical method of clamping is that on the mandrel, which is also called expansion arbor. It is put into the cleaned internal taper of the lathe spindle.

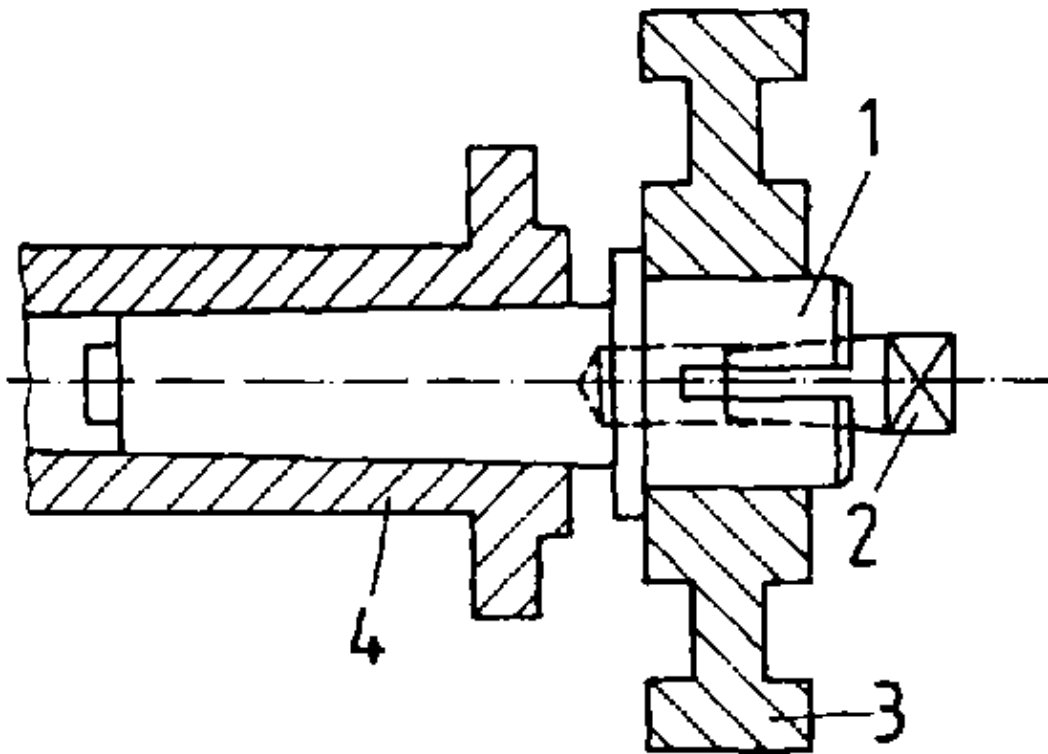

Figure 26. Arbor

- 1 clamping body, 2 taper plug, 3 workpiece, 4 lathe spindle

Premanufactured arbors can be adapted to various diameters by the lathe operator himself. They are especially suited for clamping levers and other irregularly shaped parts with a bore hole and save the use of complicated fixtures.

Other methods of clamping may be applied according to each respective kind of workpiece.

Clamping mistakes and their causes

Frequent clamping mistakes are:

- Too long projecting of the lathe tool – lathe tool is springy.
- Wrong setting-up at centre by too many backings and/or non-aligned backings – this causes chattering, canting, tool breaking,

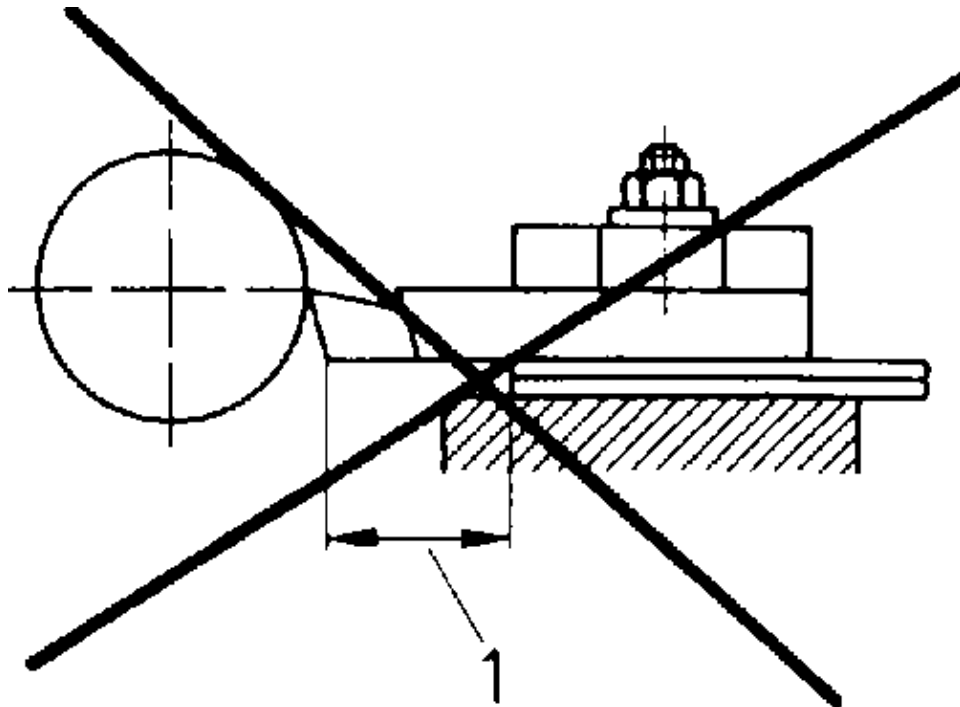

Figure 27. Lathe tool too much projecting

1 wrong clamping

- Inclination of the lathe tool due to overraised shank the consequences are: displacement of the cutting edge angles, the spindle of the clamp nut is tightened in an oblique way.

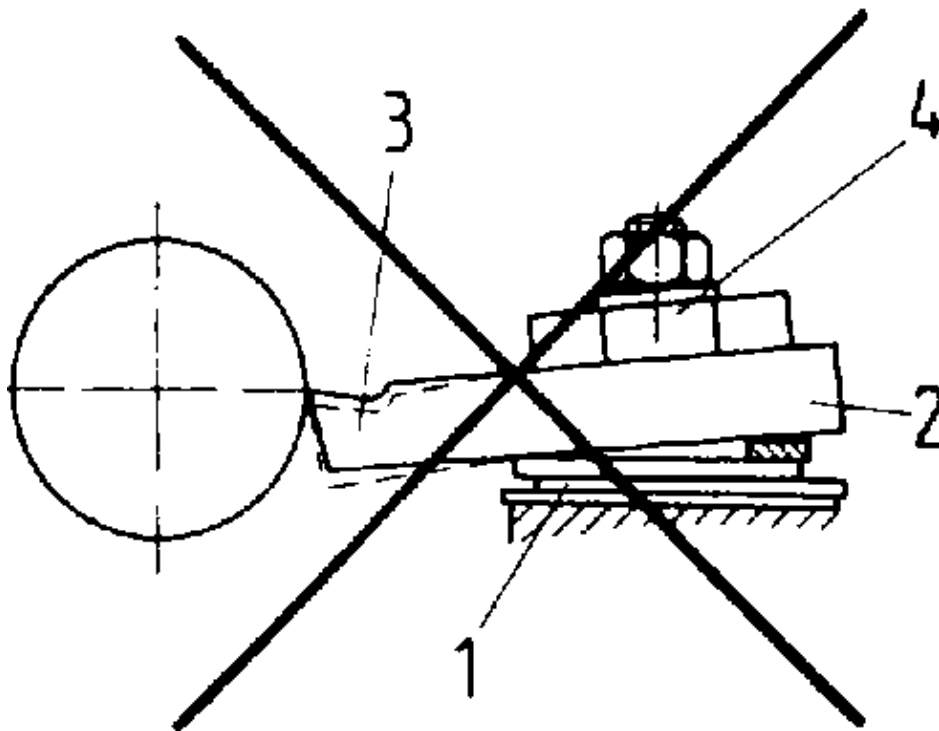

Figure 28. Wrong setting at centre

1 too many backings, 2 inclined position of the lathe tool due to overraising of the shank, 3 distortion of the cutting edge angles, 4 spindle of the clamping nut not straight

– Wrong position of the clamping jaw and/or locking screws: the lathe tool is fixed only by one edge – the service life of the tool is reduced.

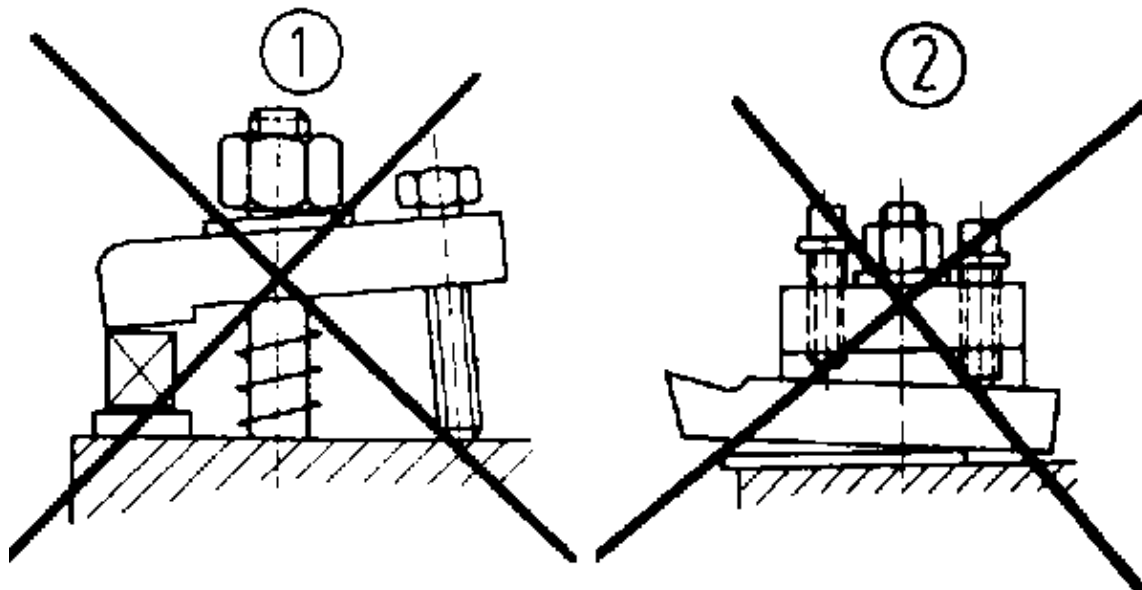

Figure 29. Wrong position of the clamping claw/clamping bolts

① clamping claw; ② clamping bolts

– Wrong position of the lathe tool: The tool is forced into the workpiece – risk of rejects.

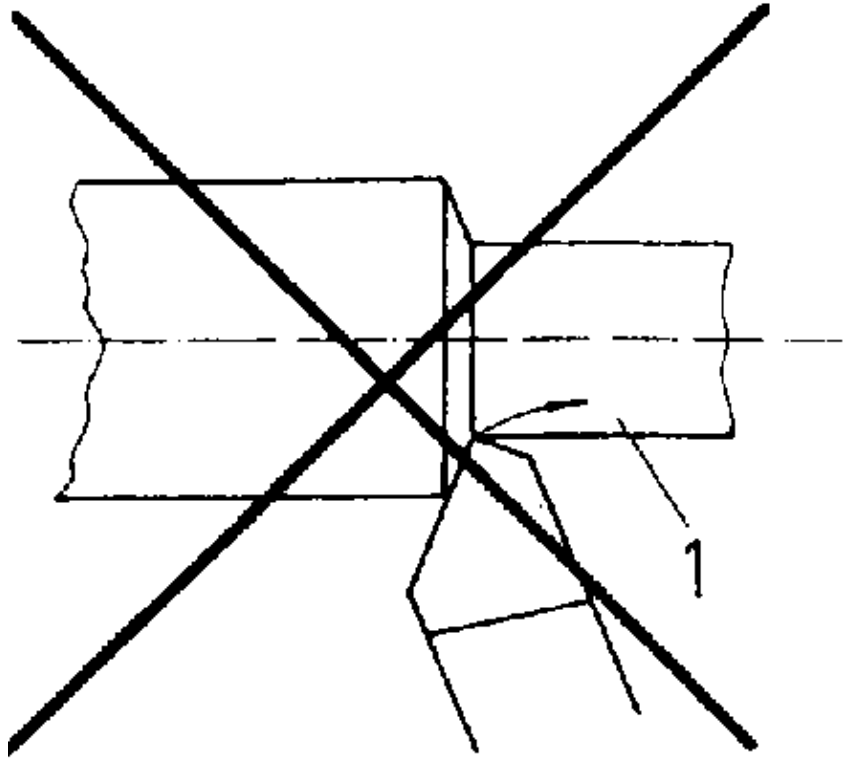

Figure 30. Wrong position of the roughing lathe tool

1 arrow points to the direction in which the tool is forced into the workpiece, workpiece becomes a reject

– Unclean quill: Foreign matters are between the tapers, which leads to rejects and tool breaking.

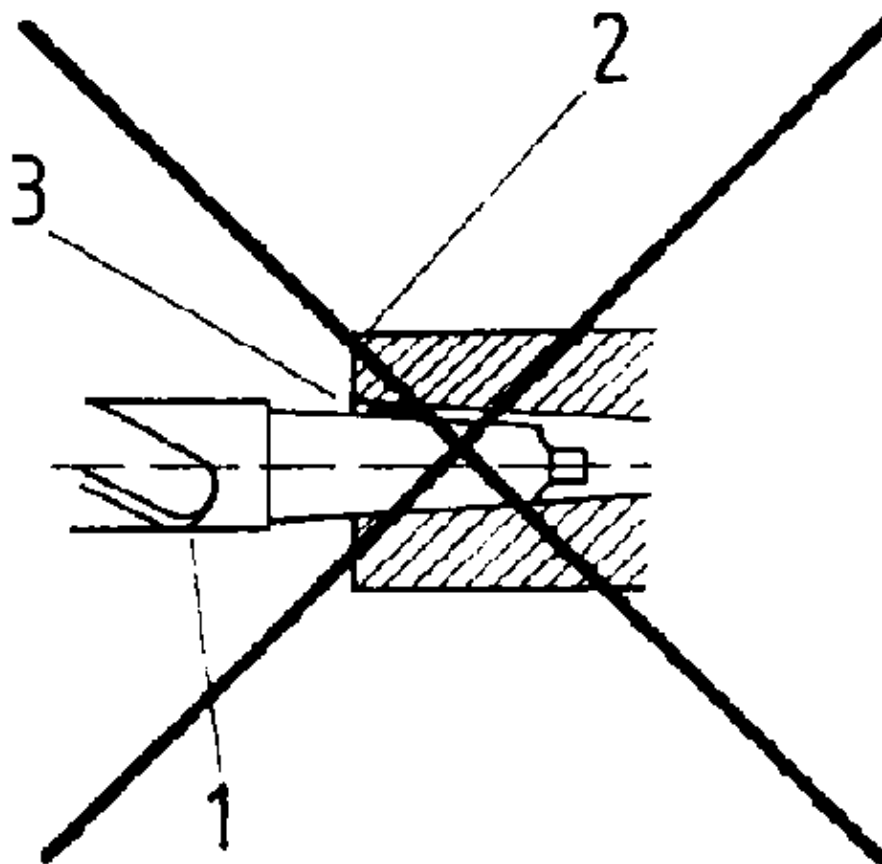

Figure 31. Foreign matters between the tapers

1 twist drill, 2 quill, 3 foreign matter

– Too much projecting of the workpieces and/or insufficient fitting to the clamping jaws – tool breaking due to chattering.

Rejects are also caused by canting of the workpiece.

Risk of accident when loosening the workpiece.

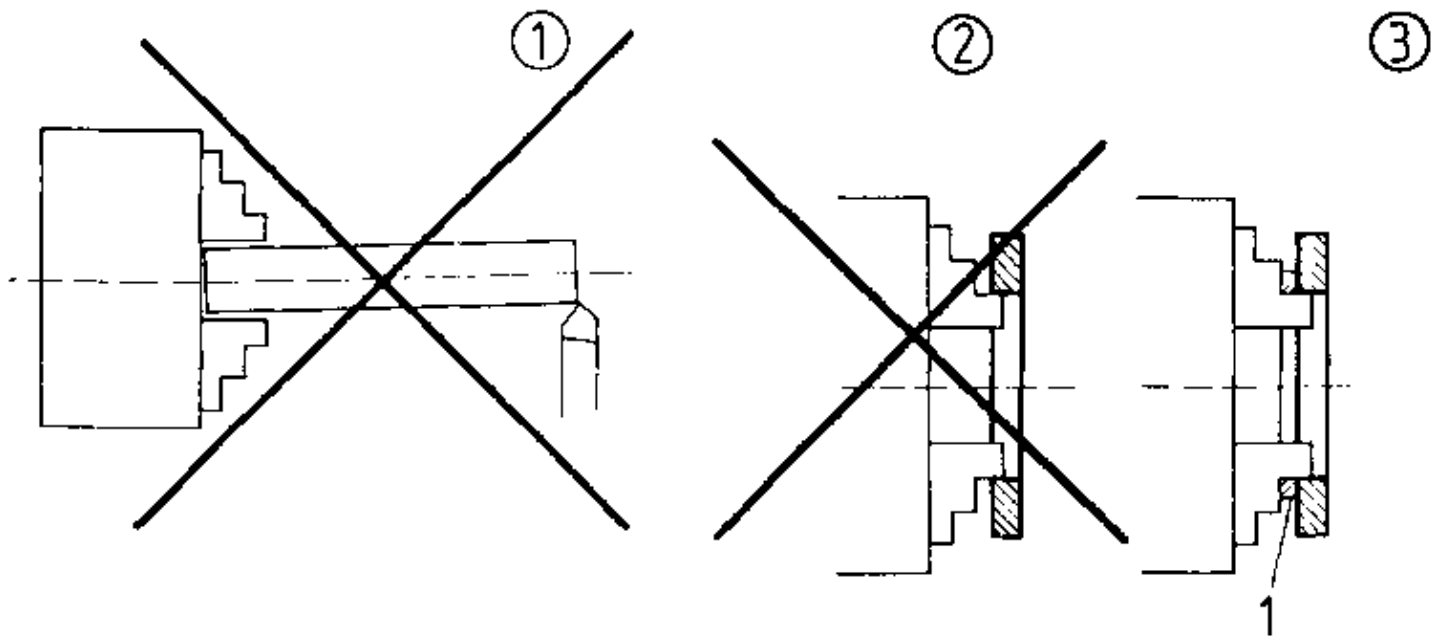

Figure 32. Workpiece projecting too much/ill-fitting clamping jaws

① too much projecting; ② thin workpieces clamped the wrong way; ③ thin workpieces are clamped against a supporting ring

1 supporting ring

How can workpieces be clamped?

What is the purpose of clamping in soft clamping jaws?

Determination of the settings (cutting values)

The settings (cutting values) resulting in the best possible economy can be determined only for one definite turning operation on one certain lathe. Cutting speed “v”:

The speed v is the distance s covered in one unit of time, i.e.

$$v = \frac{s}{t}$$

The distance s can be expressed by any unit length, e.g. in mm or in m or in km. The unit of time forming the basis of the measurement of the speed can also be chosen in any measure of time, for instance in h (hours), in min (minutes) or in s (seconds).

For the purpose of a uniform determination of the cutting speeds in the turning process, the distance s is expressed in m and the time t in min.

$$v = \frac{s}{t}$$

v	s	t
m/min	m	min

The same applies to boring, counterboring, reaming, milling, broaching, planing, slotting and shaping, for which the cutting speeds are always given in m/min.

Pay attention to the fact, that sometimes cutting speeds are given in m/s, though.

If a workpiece completes one full rotation about its axis and if the diameter of this workpiece is d , each individual point on its surface covers a distance of

$$s = d \times \pi$$

If the same workpiece does not rotate only one time but n times about its axis, the distance each individual point of its surface covers is n times as long, i.e.

$$s = n \times d \times \pi$$

Since the diameter d enters this equation in mm, but the distance s shall be determined in m (1 m = 1000 mm), the equation reads as follows:

$$s = \frac{n \times d \times \pi}{1000}$$

s	n	?	d
m	-	-	mm

If the same workpiece again rotates n times about its axis, and if these n rotations are completed in exactly 1 min, it has the rotational speed of n per minute or n/min , which can also be written as follows: $n \text{ 1/min}$ or $n \text{ r.p.m.}$

The latter way of writing is used to indicate rotational speeds.

Since with the number of rotations completed in one minute the unit time of min has entered the equation, we now have no more just the distance s , but the distance s covered in one minute, that is to say, we are now dealing with a speed v .

Thus, the equation reads like this:

$$v = \frac{n \times d \times \pi}{1000}$$

v	n	d	?
m/min	r.p.m.		-

For example:

A workpiece of a diameter of $d = 200 \text{ mm}$ rotates along the lathe tool at $n = 30 \text{ r.p.m.}$ What is the peripheral speed v ?

$$v = \frac{n \times d \times \pi}{1000} = \frac{30 \times 200 \times 3.14}{1000} = 18.84 \text{ m/min.}$$

The peripheral speed of the workpiece, at the same time, is the speed at which the turning is removed, i.e. the cutting speed.

Rotational speed “n”: As is to be seen, there are certain relations between the cutting speed v, the diameter d and the rotational speed n.

A certain diameter and a certain cutting speed result in:

$$n = \frac{1000 \times v}{d \times \pi}$$

n	v	d	?
r.p.m.	m/min	mm	–

For example:

A disk of Ø 200 mm shall be rough-machined at v = 100 m/min. The rotational speed n is to be determined.

Given: d = 200 mm, v = 100 m/min

Required: n = r.p.m.

$$\text{Calculation: } n = \frac{1000 \times v}{d \times \pi} = \frac{1000 \times 100}{200 \times 3.14} = 159.24$$

159 r.p.m.

In planning pay attention, that the cutting speed, when reaching the centre, moves towards 0, i.e. the mean diameter is used for calculation.

With individual parts, a greater diameter may be chosen. With series, a smaller one may be taken in order to avoid frequent regrinding and setting-up.

Time is saved this way.

Cutting depth “a”:

The cutting depth a in mm is the amount by which the lathe tool is fed before beginning a cut.

If possible, the entire machining allowance shall be removed in only one roughing and one finishing operation. With plain turning, it is calculated from the raw diameter d_r and the final diameter d of the workpiece according to the following equation:

$$a = \frac{d_r - d}{2}$$

Feed “s”:

The feed, or better feeding distance s in mm is the progress of the lathe tool in the direction of the cutting movement after one rotation of the workpiece. It is selected from the in-feed scale of the lathe, which is determined by the feed gear, according to the proportion a : s.

By the cutting depth a and the feed s, the sectional area of chip F is determined:

$$F = a \times s$$

Therefore, for an economical turning, a certain chip proportion $a : s$ must be observed.

With a great feed, a large quantity of chips is achieved – at the same time, the performance of the machine is increased.

Further aspects in connection with the selection of the feed are the surface quality and the material of the workpiece. What diameter is chosen for the calculation of the cutting speed with finishing?

What is the equation for calculating the cutting speed?

5. Setting-up and operating the regular engine lathe

It belongs to the preparation of each respective operation that all working and auxiliary means required are provided in a useful way according to the regulations, so that they are accessible in the shortest possible time.

The setting-up and operating of the machine is carried out according to the following steps:

– Clamping of the workpiece

- Selecting the clamping means – the workpiece must rotate during the machining process and remain in its position even with the most difficult cuts. The various dimensions and shapes of the workpieces require various corresponding ways of clamping.
- Selecting the clamping jaws – when using a clamping chuck.
- Securing true running – perhaps by using soft clamping jaws.
- With long workpieces – selection of a poppet.

The workpieces have to be clamped short and firm according to their respective shape.

– Clamping of the tool

- Short and firm clamping
- Always place in dead central position – backings according to the principle “as few as possible”.
- Decide whether single or multi-tool holder are to be used.

The tools must be examined as to their serviceability.

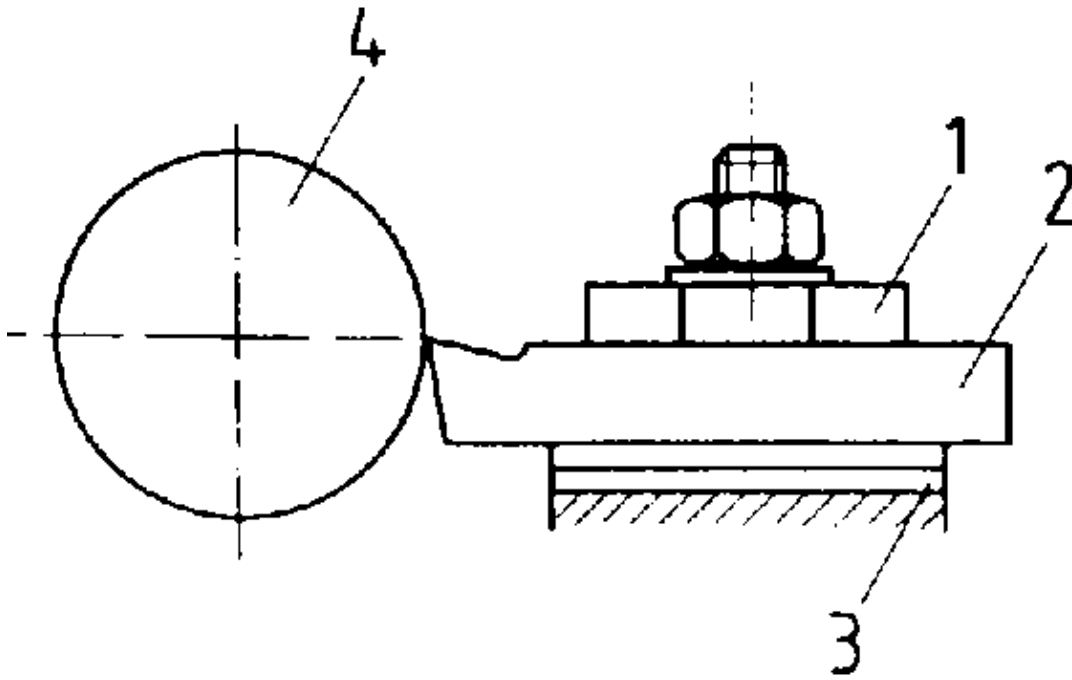

Figure 33. Clamping of the lathe tool

1 clamping claw, 2 lathe tool, 3 backings, 4 workpiece

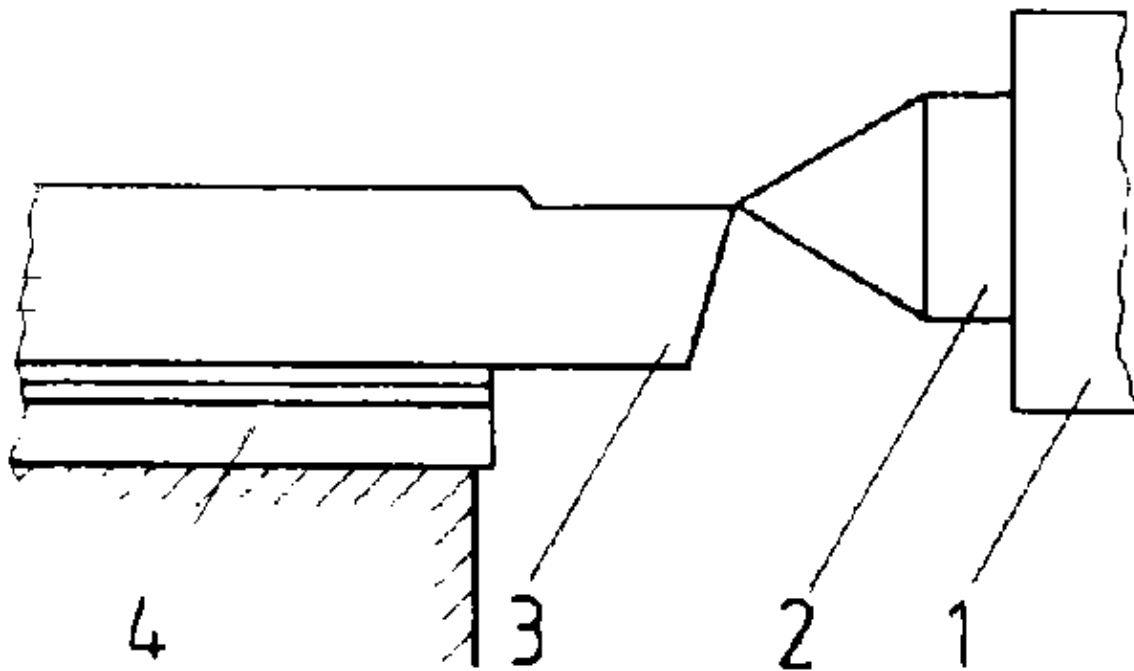

Figure 34. Vertical adjustment by tailstock centre

1 quill, 2 tailstock centre, 3 lathe tool, 4 backings

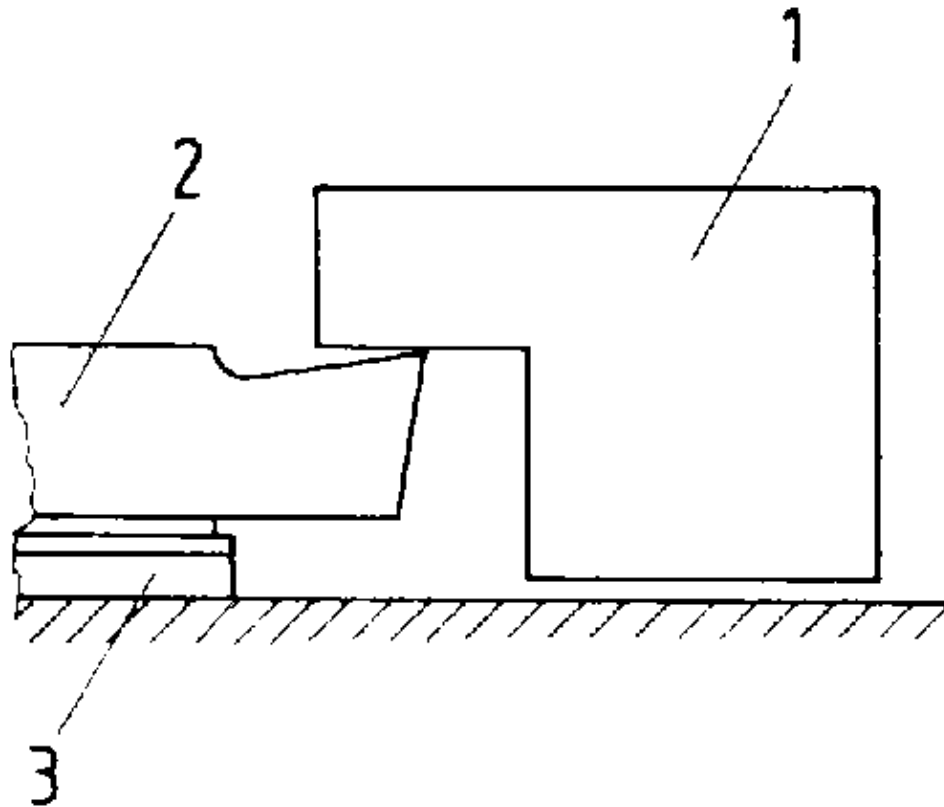

Figure 35. Vertical adjustment by setting gauge

1 machine-bound setting gauge, 2 lathe tool, 3 backings

– Setting–the cutting parameters

- Setting of the rotational speed taking the existing speed tables and switching symbols into consideration.

Switching only when the machine is at rest!

- Setting of the feed.

In case of replacement of the change gears, switch off the main switch before opening the gear case.

Why should the shims be selected according to the principle “as few as possible”?

What is the required rotational speed for machining a workpiece of St. 60 of a diameter of 65 mm using a carbide-tipped lathe tool?

a) For cylindrical turning

b) For surfacing

Formula: $n = \frac{v \times 1000}{d \times \pi}$ r.p.m.

Cylindrical turning:

Given: $v = 80 \text{ m/min}$ $d = 65 \text{ mm}$ $\pi = 3.14$

Required: n r.p.m.

Calculation:

=====

Surfacing:

Given: $v = 80 \text{ m/min}$ $d = 65 \text{ mm}$ $\pi = 3.14$

Required: $n \text{ r. p.m.}$

Calculation:

=====

How is the rotational speed selected, when surfacing single parts or series?

What does the selection of the feed depend on?

For operating the regular engine lathe, the following rules have to be observed (sequence of operations):

- Switching the lathe on
- Approaching the tool carrier with the lathe tool towards the workpiece
- Entering the cut at the workpiece with the help of the hand feed
- Infeed by tool rest and surfacing of the workpiece
- Setting of the dog, length adjustment by log measure
- Beginning the cut at the area of the cylindrical surface of the workpiece by hand feed

Beginning the cut at the workpiece only with the machine running, because otherwise the main cutting edge of the lathe tool will chip.

- Putting the scale of the cross slide on 0 and carry out the required feed operation for achieving the desired diameter (in the case of too much infeed, turn the crank back by one revolution in order to compensate backlash and start the feeding movement again).
- Starting the cut with 1–2 mm, then the tool carrier is returned (see fig. 36)
- Switching the machine off and dimensional inspection
- Switching the machine on – perhaps dimensional correction
- Switching on the automatic feed
- 1 – 2 mm before reaching the stop, switch the automatic feed off and continue by hand feed till the stop is reached.

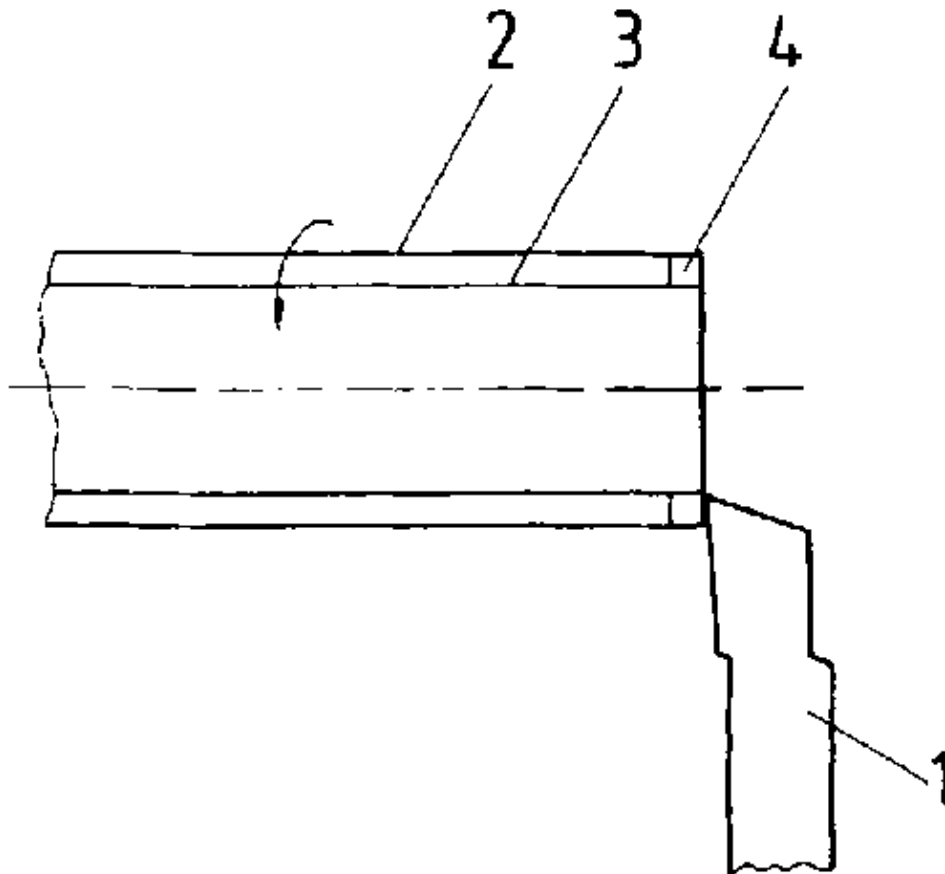

Figure 36. Starting the cut at the workpiece for dimensional inspection

1 right side cutting turning tool, 2 rough size of the workpiece, 3 final size of the workpiece, 4 starts of cuts at the workpiece for dimensional inspection

- Return cross slide (lathe tool)
- Return tool carrier to original position
- Switching the machine off, dimensional inspection
- Unclamping of the workpiece.

A workpiece has a diameter of 50.8 mm and shall be reduced to $\text{Ø} 50.4$. By how many graduation marks must the crank be moved on if one graduation mark is equivalent to a lathe tool feed of 0.05 mm?

Solution:

What steps have to be taken if, with the tool infeed to final size, a too great feed was set by mistake?

6. Maintenance and care of the regular engine lathe

Like all machine tools, regular engine lathes are subject to permanent wear.

By constant care and maintenance of the machines wear can be controlled and kept low.

The following principles have to be observed:

- The operating instructions are decisive for the use and maintenance of the machine. They must be carefully observed.
- Before beginning the daily work, all parts of the machine that have to be lubricated by hand have to be oiled according to the instructions. Uninsufficient lubrication leads to early abrasion. For centralized and circulating lubrication make sure that the quantity of oil is sufficient.

The oil strainers have to be cleaned regularly and at the required intervals.

The following principle applies to the lubrication of a machine:

The prescribed quantity of the prescribed lubricant to the respective lubrication points of the prescribed time.

- Before putting the machine into operation make sure that all levers are in their correct positions. Wrong lever positions may lead to breaks.
- All guideways must be protected against chips, scale, dust and abrasion of any kind. Otherwise they will wear out soon and inaccurate work would be the result.
- Guideway parts which are not used must be protected against contamination by protective equipment.
- Make sure that the workplace is always in order. Clamping means and change gears must be kept in their proper places. On the regular engine lathe, the required tools must be well ordered and ready to hand on the protective boards.

Recessing, Cutting-out and Cutting-off – Course: Techniques for Machining of Material. Instruction Examples for Practical Vocational Training

Table of Contents

<u>Recessing, Cutting-out and Cutting-off – Course: Techniques for Machining of Material.</u>	
<u>Instruction Examples for Practical Vocational Training</u>	1
<u>Introduction</u>	1
<u>Instruction example 4.1.: Joint bolt</u>	2
<u>Instruction example 4.2.: Clamping bush</u>	4
<u>Instruction example 4.3.: Flange</u>	5
<u>Instruction example 4.4.: Spring plate</u>	8

Recessing, Cutting-out and Cutting-off – Course: Techniques for Machining of Material. Instruction Examples for Practical Vocational Training

Institut für berufliche Entwicklung e. V.
Berlin

Original title:
Lehrbeispiele für die berufspraktische Ausbildung
"Ein-, Aus- und Abstechen"

Author Horst Köth

First edition © IBE

Institut für berufliche Entwicklung e.V.
Parkstraße 23
13187 Berlin

Order No.: 90-33-3204/2

Introduction

The present booklet contains 4 selected instruction examples which are intended to help practising and consolidating knowledge and skills acquired in the working techniques "recessing, cutting-out and cutting-off".

In order to facilitate the preparation and execution of the work, the necessary materials, cutting and operating tools, measuring and testing tools, and accessories are stated for each instruction example.

For the instruction examples 2, 3, 4 the steel is specified according to the value of its tensile strength in the unit "Megapascal" (MPa).

We also recommend knowledge required in addition to the knowledge of "recessing, cutting-out and cutting-off" which should be repeated before starting with the work.

Explanations to the workshop drawings, if necessary, are given before the specification of the technological sequence of operations. The specified sequence of operations gives the steps necessary for the production of the relevant workpiece. This sequence of operations should be strictly observed if good quality is to be achieved.

For each training example a workshop drawing is attached showing the required shapes and dimensions of the workpiece. The admissible deviations for sizes with no indication of tolerances may be taken from the table below.

Nominal size	Admissible deviation in mm
0.5 – 6	± 0.1
6 – 30	± 0.2
30 – 120	± 0.3
120 – 315	± 0.5

The admissible surface roughness Rz is specified in μm (0.001 mm)

Instruction example 4.1.: Joint bolt

This example serves to practise recessing of external grooves in circumferential surfaces in the form of a grinding recess and a thread groove on a joint bolt.

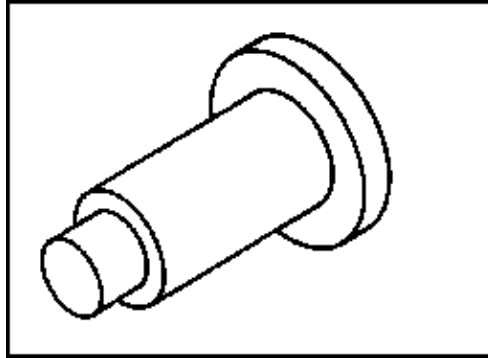

Material

16 Cr Mo 4 (low-alloy steel, alloy constituents: 0.16 % carbon, 1 % chromium, less than 1 % molybdenum, rest iron)

Dimensions

dia. 52×107 mm

Cutting and operating tools

Straight right-hand end-cut turning tool (grind to suit shape and width of recesses), chuck key, open-end wrench and box wrench

Measuring and testing tools

Vernier caliper

Accessories

Supporting plates for turning tool, soft chuck jaws, live centre

Required previous knowledge

Reading of drawings, measuring and testing, types and application of clamping tools and accessories.

Explanations to the workshop drawing

Undercut A 4×0.3: A = shape, 4 = width of recess, 0.3 = depth of recess (i.e., dia. 0.6 mm smaller)

Thread M 20: M = metric thread, 20 = nominal diameter in mm

Fit 30 h 6: 30 = nominal size, h 6 = tolerance for shaft

Sequence of operations

Remarks

- | | |
|---------------------------|--|
| 1. Dimensional inspection | Apply vernier caliper. |
| 2. Clamping of workpiece | Chuck in stepped, soft chuck jaws, use live centre as counter-support. |
| 3. Clamping of tool | Position end-cut turning tool exactly in line with centre. To avoid jamming of turning tool, make sure that tool point is tapered from front to rear and from top to |

bottom.

4. Setting of cutting values

Use existing tables of cutting values.

5. Recessing of grinding recess A 4x0,3 on dia. 30 h 6

Switch on lathe. End-cut turning tool to take first cut on circumferential surface 30 mm dia. of rotating part. Set cross slide scale to "0". Set depth of cut. Return tool carrier to initial position, switch off machine for dimensional inspection.

6. Recessing of thread groove on dia. M 20

Switch on lathe. End-cut turning tool to take first cut on circumferential surface 20 mm dia. of rotating part. Set depth of cut. Return tool carrier to initial position, switch off machine for dimensional inspection. Inspect surface finish. Cover turning tool for any measuring done on the lathe.

7. Unloading of workpiece

8. Dimensional and surface inspection

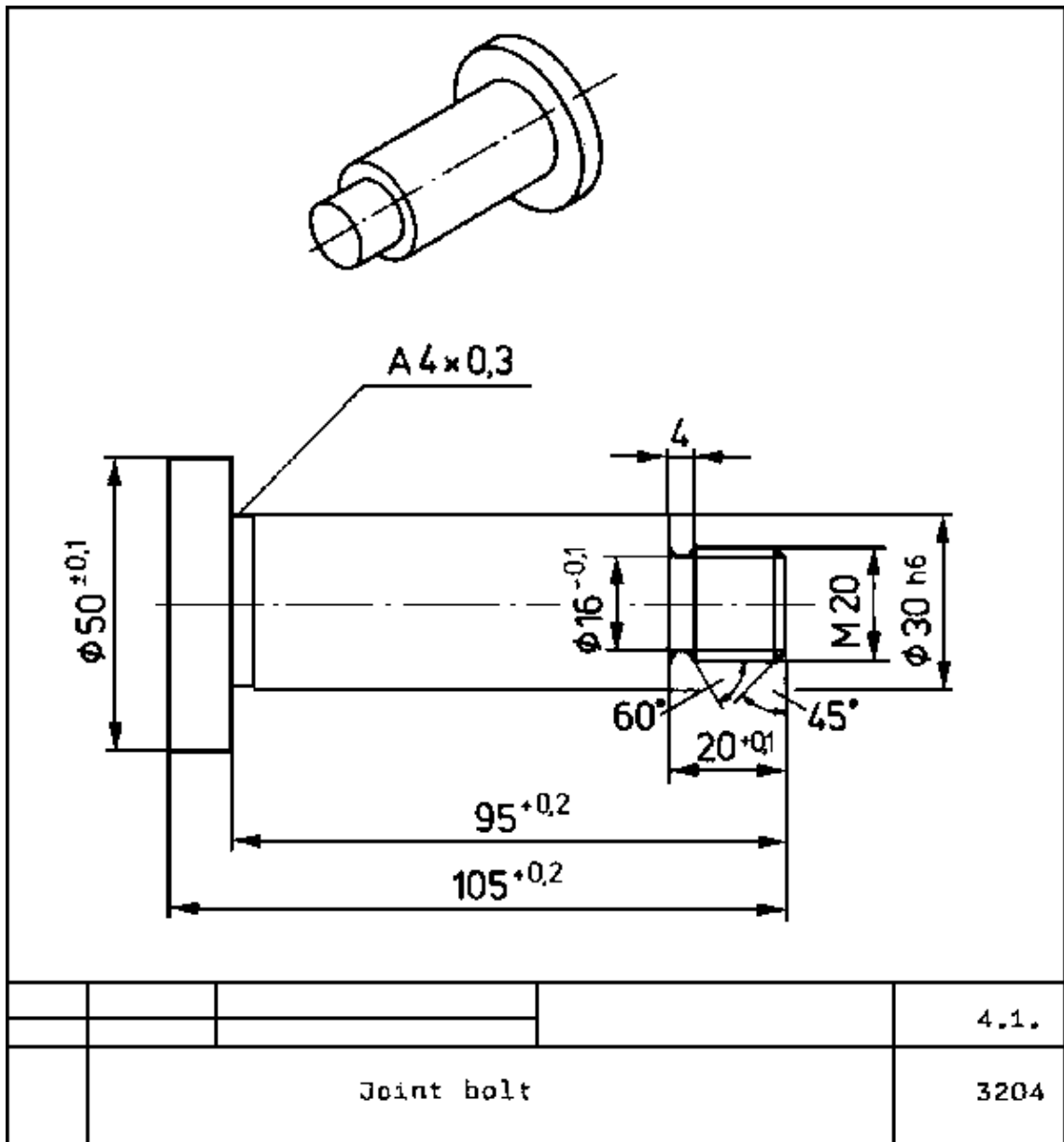

Instruction example 4.2.: Clamping bush

This example serves to practise recessing of internal grooves in hollow parts in the form of a thread groove in a clamping bush.

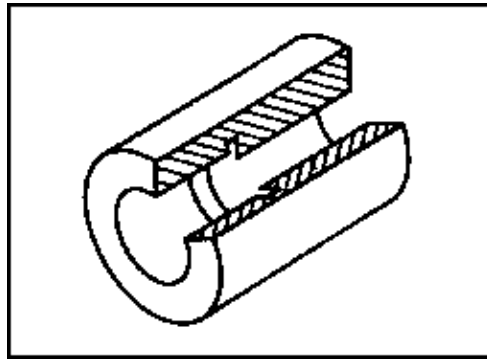

Material

St 34 b – 2 (St = steel, 34 = tensile strength 340 MPa, b = deoxidizing degree: dead, 2 = grade 2)

Dimensions

dia. 70×105 mm

Cutting and operating tools

Hook tool (grind to suit shape and width of recess), chuck key, open–end wrench and box wrench

Measuring and testing tools

Vernier caliper. inside caliper, dial gauge

Accessories

Supporting plates for turning tool, soft chuck jaws, stop, 60 mm block gauge

Required previous knowledge

Reading of drawings, measuring and testing, types and application of clamping tools and accessories

Explanations to the workshop drawing

Thread M 40×1.5: M = metric thread, 40 = nominal dia. in mm,

1.5 = pitch in mm

Fit 30 H 6: 30 = nominal size, H 6 = tolerance for hole

Sequence of operations

Remarks

- | | |
|------------------------------|--|
| 1. Clamping of workpiece | Type of clampings chucking in soft chuck jaws, check for true running. |
| 2. Clamping of tool | Ensure central position with respect to axis of rotation. Short and firm clamping is essential (to avoid chatter marks). |
| 3. Setting of cutting values | Work with low cutting speed since hook tool cannot withstand high forces because of weak cross section. |
| 4. First cut on end face | Set stop and insert 60 mm block gauge. Tool to take first cut on the end face of the rotating part. Remove block gauge, return tool carrier. |

5. Recessing dia. 44

Move tool carrier to stop, take first cut on circumferential surface. Set cross slide scale to "0" and finish turning diameter 44. Return tool carrier to initial position.

6. Unloading of workpiece

Cover hook tool to avoid accidents.

7. Dimensional and surface inspection

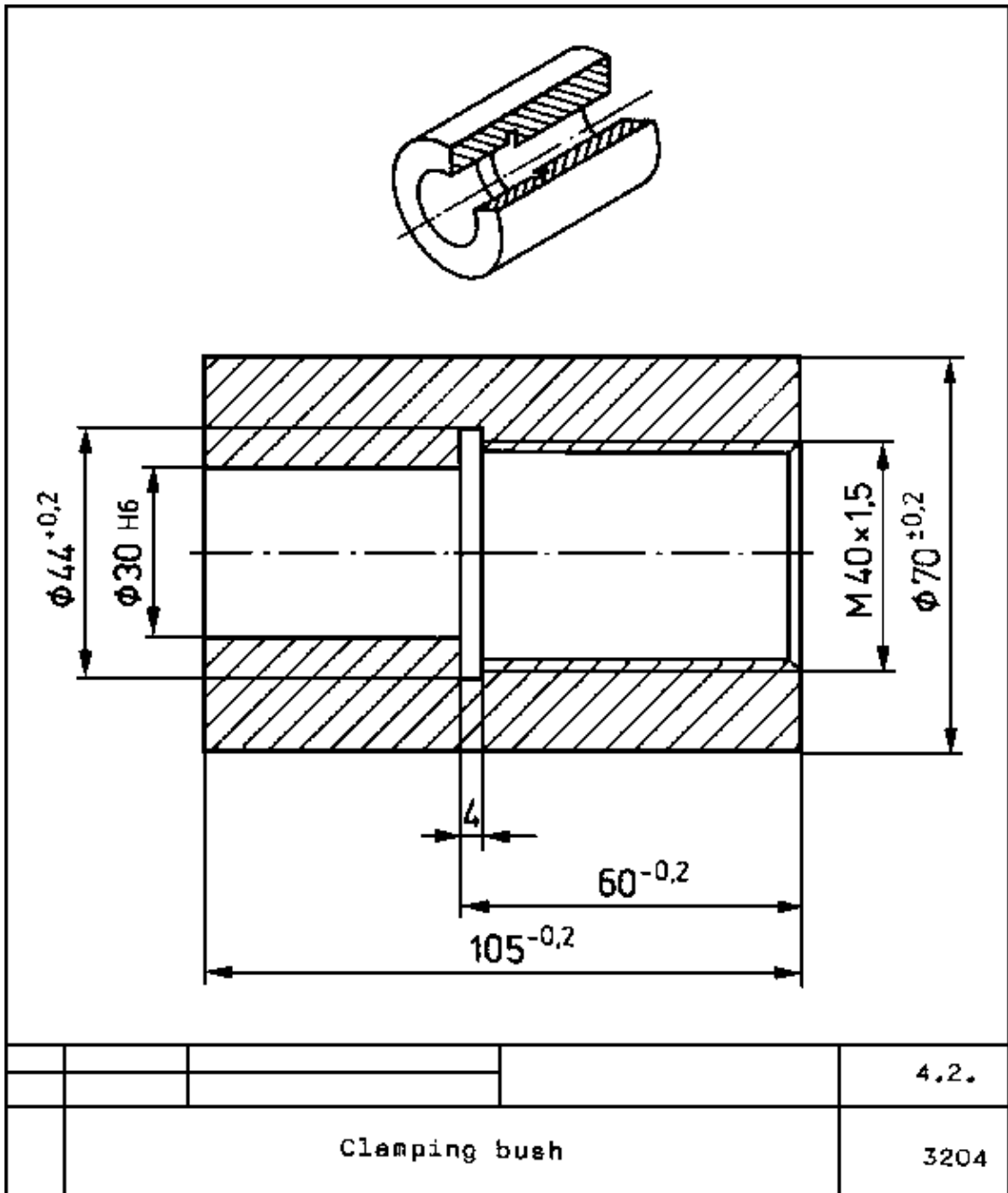

Instruction example 4.3.: Flange

This example serves to practise cutting-out of disks and rings.

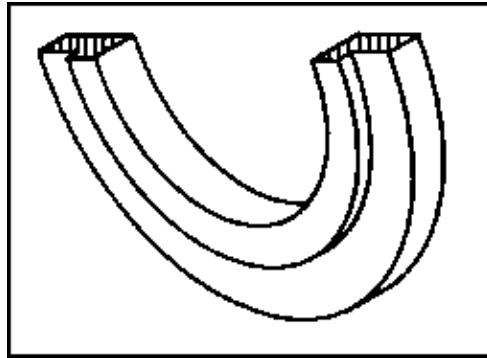

Material

St 45 (St = steel, 45 = 450 MPa tensile strength)

Dimensions

dia. 150×15 mm

Cutting and operating tools

Straight right-hand/left-hand end-cut turning tool (width approx. 10 mm), internal side-cutting tool (boring tool) for through holes, chuck key, open-end wrench and box wrench

Measuring and testing tools

Vernier caliper, depth gauge

Accessories

Supporting plates for turning tools, stepped, soft chuck jaws, 14.8 mm block gauge

Required previous knowledge

Reading of drawings, measuring and testing, types and application of clamping tools and accessories

<u>Sequence of operations</u>	<u>Remarks</u>
1. Clamping of workpiece	Type of clamping: chucking in soft, stepped chuck jaws.
2. Clamping of tool	Ensure central position and short and firm clamping of tool. Pay attention to proper relief-grinding.
3. Setting of cutting values	Work with low cutting speed since tool cannot withstand high forces because of weak cross section.
4. First cut on end face	Set stop and insert 14.8 block gauge. Turning tool to take first cut on end face of the rotating part. Remove block gauge.
5. Cutting-out dia. 100 mm to 99.5 mm	Since tool cannot withstand high forces because of weak cross section, work with low feed rate and ensure sufficient supply of coolant. Cutting through would imply danger of tool breakage (therefore depth of recess 0.2 mm before cutting through).
6. Unloading of workpiece and tool	Remove core by hammer blows.
7. Clamping of workpiece	
8. Clamping of tool	For round shank use Vee support .

9. Turning dia. 100 mm Primary cutting edge to take first cut on dia. 99.5 mm and set required size. Use internal side-cutting tool.
10. Deburring Chamfer edges.
11. Unloading of workpiece
12. Dimensional and surface inspection.

For batches of workpieces repeat sequence of operations until operation 5 and continue with operation 6 at the end of the batch.

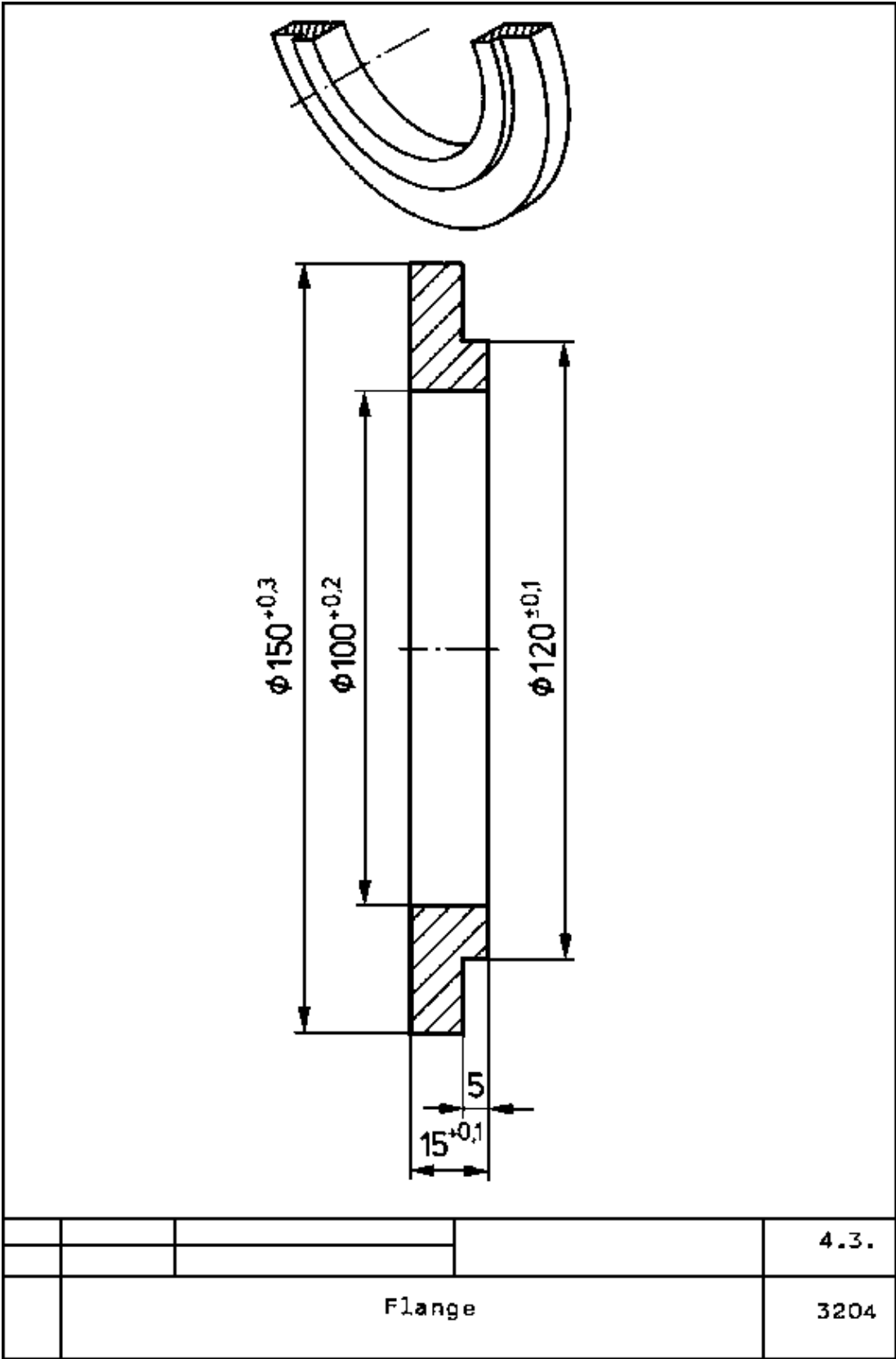

Instruction example 4.4.: Spring plate

This example serves to practise cutting-off.

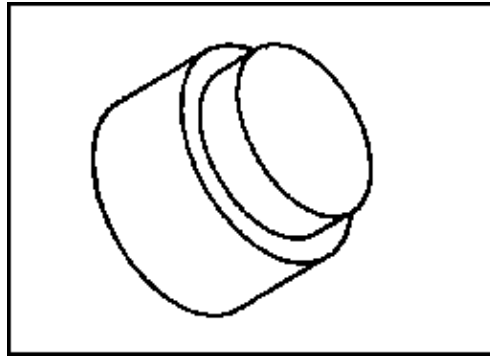

Material

St 37 (CSt = steel. 37 a 370 MPa tensile strength)

Dimensions

dia. 18 (bars)

Cutting and operating tools

Straight right-hand end-cut turning tool (4 mm), chuck key, open-end wrench and box wrench

Measuring and testing tools

Vernier caliper, steel tape-rule

Accessories

Supporting plates for turning tools, chuck jaws, stop. 9.5 mm and 11 mm block gauges

Required previous knowledge

Reading of drawings, measuring and testing, types and application of clamping tools and accessories

Explanations to the workshop drawing

Rz 20: Description of surface finish

Rz = roughness, 20 = roughness height in μm (finished)

Sequence of operations

Remarks

- | | |
|--|--|
| 1. Clamping of workpiece | Type of clamping: chucking in hard chuck jaws. |
| 2. Clamping of tool | Locate tool exactly in central position. |
| 3. Setting of cutting values | Set low cutting speed since tool cannot withstand high forces because of weak cross section. |
| 4. Moving of tool carrier in working position | Move end-cut turning tool as close to chuck as possible. Fix stop. |
| 5. Set length of workpiece | Set workpiece to 12 mm length by means of steel tape-rule. Move tool carrier to stop. |
| 6. Turning of shoulder 17 mm dia. | |
| 7. Turning of shoulder dia. 13×2 mm and facing of end face 13 dia. | Insert 9.5 mm block gauge. Recess to dia. 13 mm. Insert 11 mm block gauge and face end face. |
| 8. Cutting-off the part | Remove block gauges. Use end-cut turning tool with |

oblique grind to remove cutting-off flash.

For batches of workpieces repeat operations 5 to 8. Face and deburr at the end of the batch with chuck, soft chuck jaws and right-bent roughing tool.

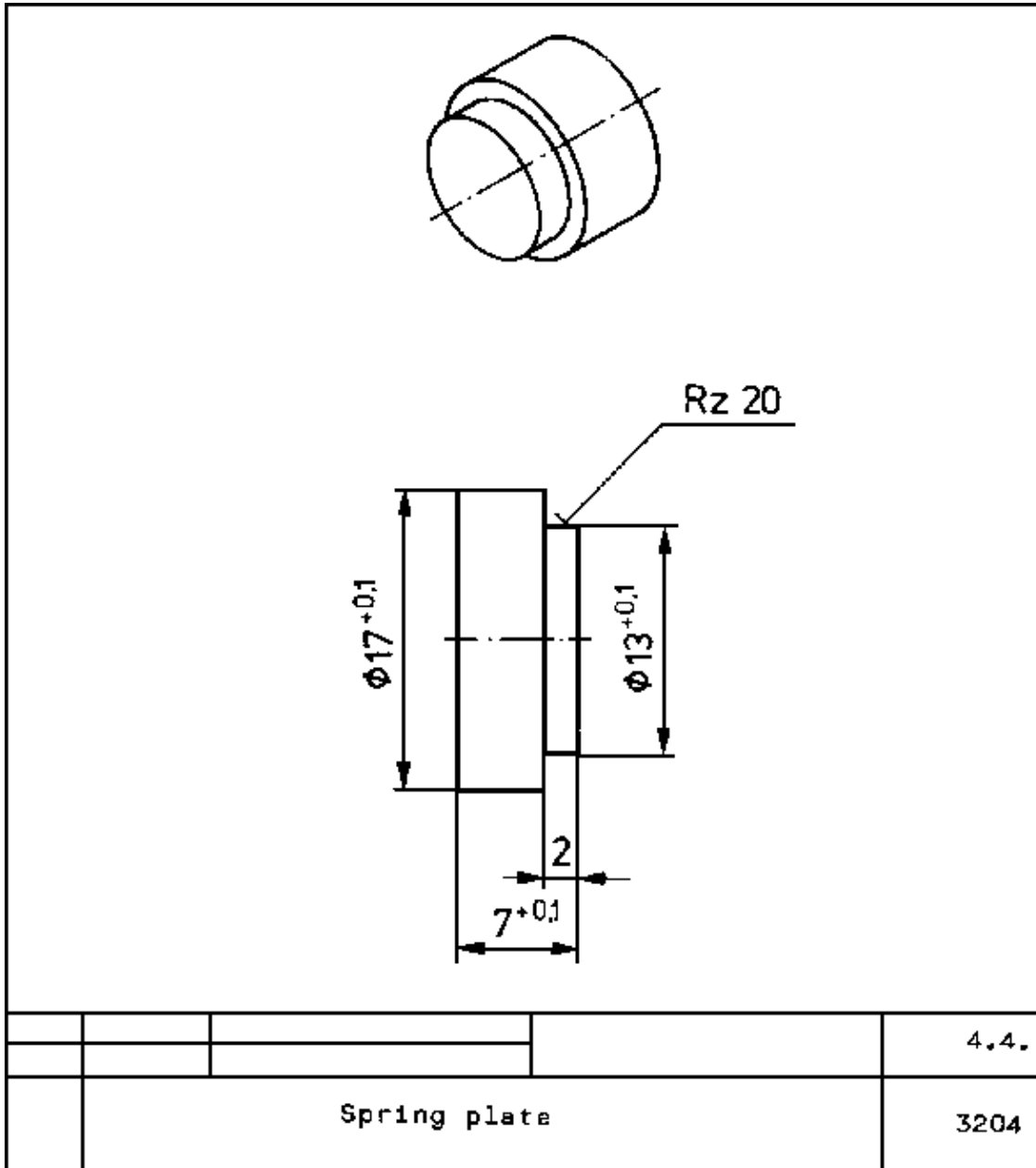

**Recessing, Cutting-out and Cutting-off – Course: Techniques for
Machining of Material. Trainees' Handbook of Lessons**

Table of Contents

<u>Recessing, Cutting-out and Cutting-off – Course: Techniques for Machining of Material. Trainees' Handbook of Lessons</u>	1
<u>1. Purpose and importance of recessing, cutting-out and cutting-off</u>	1
<u>2. Design and types of turning tools to be used</u>	1
<u>3. Preparation of recessing, cutting-out and cutting-off</u>	4
<u>4. Recessing of external and internal grooves</u>	7
<u>5. Cutting-out of disks and rings</u>	9
<u>6. Cutting-off of solid stock and hollow parts</u>	10

Recessing, Cutting-out and Cutting-off – Course: Techniques for Machining of Material. Trainees' Handbook of Lessons

Institut für berufliche Entwicklung e. V.
Berlin

Original title:
Arbeitsmaterial für den Lernenden
"Ein-, Aus- und Abstechen"

Author: Horst Köth

First edition © IBE

Institut für berufliche Entwicklung e.V.
Parkstraße 23
13187 Berlin

Order No.: 90-35-3204/2

1. Purpose and importance of recessing, cutting-out and cutting-off

Recessing, cutting-out and cutting-off are turning techniques often used.

These techniques permit intricate shapes to be produced.

The recessing (necking, grooving) technique as metal-cutting operation serves to produce

- undercuts for the production of threads,
- recesses in circumferential surfaces or hollow parts for grinding of simple and intricate workpieces,
- grooves for intricate machine parts, such as grooves for V-belts, oil grooves, snap rings, annular grooves.

Cutting-out can be used for cylindrical turning of sheet-metal parts and for economical production of rings from solid material with savings in material (cut-out material can be used for further processing). The cutting-out technique as metal-cutting operation serves

- to machine intricate sheet-metal parts which shall be turned cylindrically,
- to produce rings from solid material,
- to prevent deformations of thin-walled rings.

The cutting-off (parting-off) technique as metal-cutting operation serves to

- economically produce workpieces from bar stock with the shape, dimensions and surface finish required.

2. Design and types of turning tools to be used

For recessing, cutting-out and cutting-off the end-cut turning tool and hook tool are mostly used.

The end-cut turning tool is used for machining on the circumferential surface. The hook tool serves to machine hollow parts.

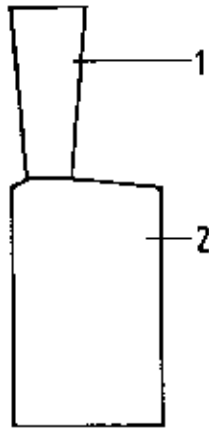

Figure 1 Right-hand end-cut turning tool

- 1 tool point (or tool nose)
- 2 shank

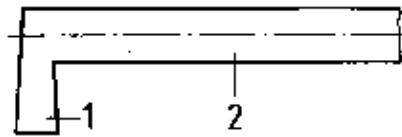

Figure 2 Hook tool

- 1 tool point (or tool nose)
- 2 shank

What are the main components of an end-cut turning tool?

1. _____
2. _____

For special shapes of grooves and recesses, the turning tools to be used are ground to suit the shape to be produced.

In order to maintain the shape of the cutting portion and to save cutting tool material, the end-cut turning tool is reground on the cutting face only.

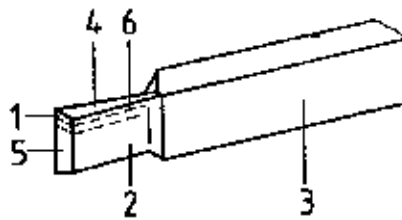

Figure 3 Right-hand end-cut turning tool

- 1 side-cutting edge (or primary cutting edge),
- 2 end flank,
- 3 shank,
- 4 cutting face,
- 5 flank,
- 6 regrind

When grinding the end-cut turning tool, special attention is to be paid to maintaining the angles.

The following rules are to be observed:

- Length of the cutting portion depends on the depth of the recess to be produced.
- Clearance angle and rake angle depend on the material of the workpiece.
- Tapering from front to rear and top to bottom to avoid jamming.

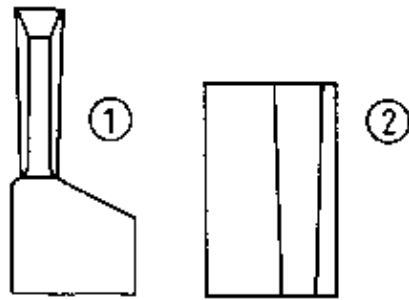

Figure 4 Tapering of cutting edges

- (1) from front to rear
- (2) from top to bottom

– For cutting–out and cutting–off the primary cutting edge is ground obliquely so that the corner of the edge facing the workpiece is slightly leading. This avoids hooking or breaking off when parting, and no parting–off flash is left on the workpiece.

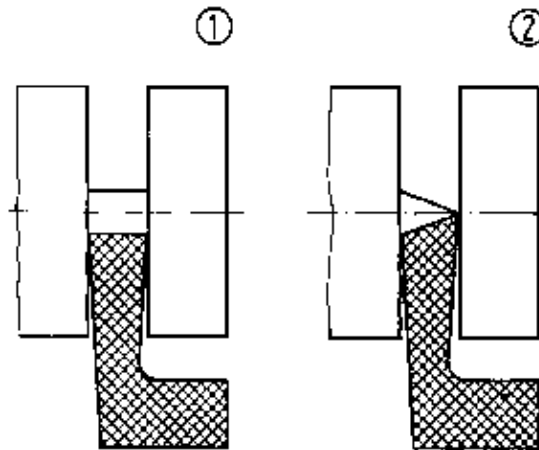

Figure 5

- (1) unfavourable shape of cutting edge
- (2) correct shape of cutting edge

In order to guarantee economical machining of large quantities of workpieces, a special grinding angle (roof type) is used for the cutting–off tool which permits the tool life to be increased and high cutting speeds to be used.

– For cutting–out, a special grinding angle is applied to the secondary cutting edge to avoid "dragging".

Re–grinding at the side weakens the end–cut turning tool. It results in high wear and the danger of breaking off.

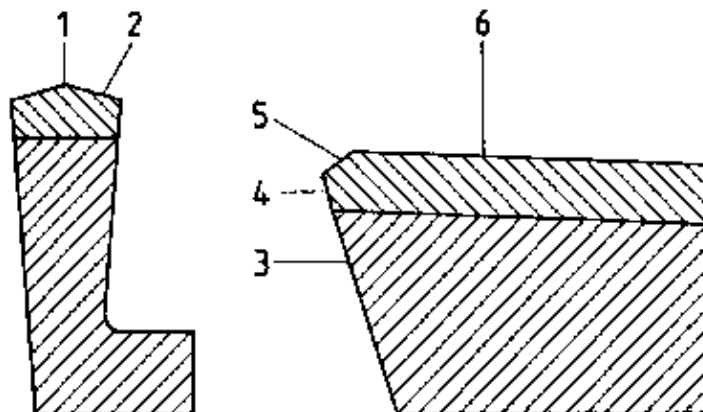

Figure 6 End–cut turning tool with roof–type grind

- 1 cutting relief 0.1 – 0.2,
- 2 trailing edges 100,
- 3 flank 12°,
- 4 tool point 6–8°,
- 5 tool point 30° x 0.1,
- 6 cutting face

The special grind is lapped.

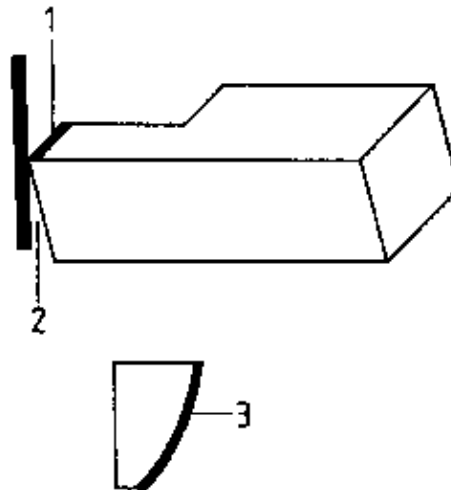

Figure 7 Right-hand end-cut turning tool with special grinding for cutting out

- 1 primary cutting edge
- 2 flank
- 3 special grind

What is to be considered when grinding an end-cut turning tool?

Because of the intricacy of the recesses and of the constantly changing cutting speed in cutting-off, cutting tools of high-speed steel are normally used since carbide-tipped end-cut turning tools often chip.

Why does the cutting speed constantly change when the cutting edge of the end-cut turning tool is approaching the centre?

3. Preparation of recessing, cutting-out and cutting-off

The preparation of the relevant operations includes to properly and duly make available all tools, materials and auxiliary means needed.

In doing so, the following rules are to be observed:

- Check the tools for serviceability. Use serviceable tools only.
- Tools to be used must not be placed one above another.
- Store tools in clean condition.
- Store measuring and testing tools on adequate supports only.

- Select the necessary auxiliary means according to the work order and place them at disposal on adequate supports (sup–porting plates for turning tools, boring rings, live centre, stop, block gauge, chuck key, stationary steady rest).

Never leave the chuck key in the chuck because of danger of accidents when switching on the machine.

What is to be considered when checking the tools for service–ability?

Setting–up of the machine mainly involves the following steps:

- Clamping/chucking of the workpiece for recessing
 - Internal turning (turning out) of soft chuck jaws since the parts to be turned are already pre–machined.

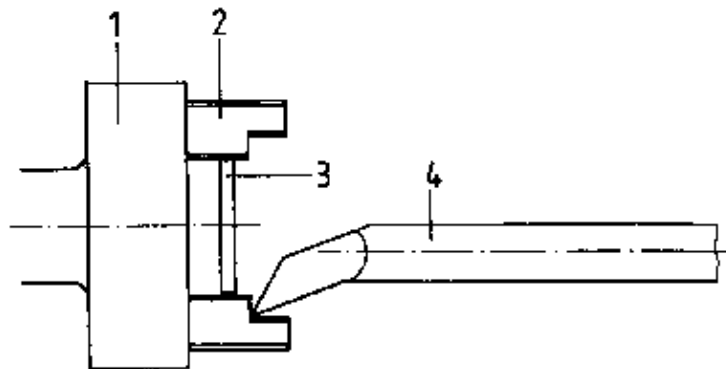

Figure 8 Internal turning of soft chuck jaws

- 1 three–jaw chuck
- 2 soft chuck jaws
- 3 boring ring
- 4 internal side–cutting tool (or boring tool).

Internal turning of the chuck jaws guarantees true running of the parts and prevents the surface of the parts to be damaged.

- Clamping/chucking of the workpiece for cutting–out .
 - Internal turning of soft chuck jaws.
 - Use of thrust pads when machining sheet metal and thin–walled parts.

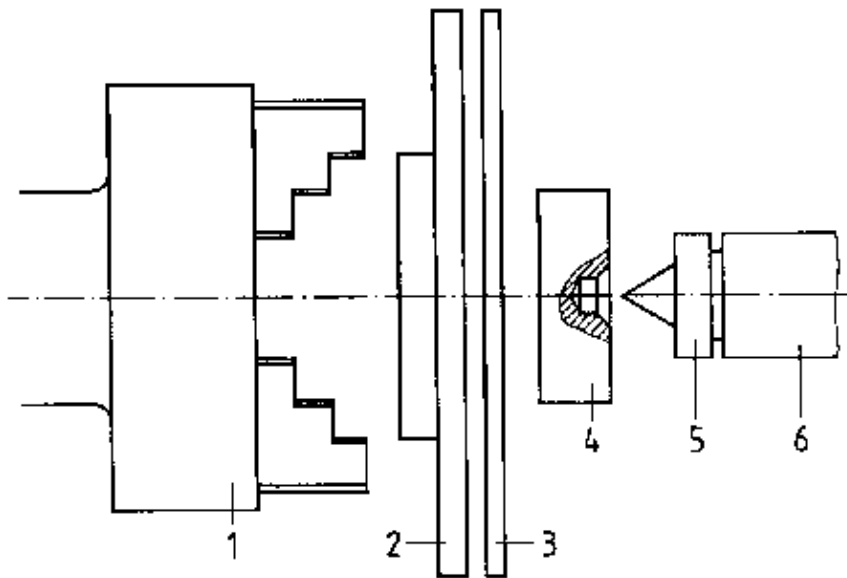

Figure 9 Use of thrust pads

- 1 three-jaw chuck,
- 2 thrust pad – chucked in three-jaw chuck,
- 3 workpiece,
- 4 thrust pad as counter-support,
- 5 live centre,
- 6 tailstock sleeve

– Clamping/chucking of the workpiece for cutting-off

- Three-jaw chuck and hard chuck jaws (for bar stock).
- Internal turning of soft jaws (for pre-machined parts and hollow parts).

– Clamping of the tools

- Always ensure short and firm clamping of the end-cut turning tool/hook tool exactly in central position to avoid springing, hooking and breaking off of the tool.
- For long, thin workpieces use steady rest, if necessary.
- Choose supporting plates of adequate thickness (to avoid clamping with several supporting plates). In case of bad spindle bearing, hooking of the end-cut turning tool can be avoided by clamping the tool upside down and rotating the chuck in anti-clockwise direction.

When cutting-off with the tool clamped upside down, the chuck is to be secured against getting loose unintentionally.

– Setting of the cutting values

What rotational speed will be necessary for a recess on a 30 mm diameter of a part of St 60 steel using an end-cut turning tool made of high-speed steel?

Formula: _____

given: _____

required: _____

Calculation:

What rotational speed is to be selected for cutting-off disks from St 60 solid stock of 140 mm diameter? (Turning tool used is made of high-speed steel)

Formula: _____

given: _____

required: _____

Calculation:

Give the reasons for the selection of the speed:

4. Recessing of external and internal grooves

With the recessing technique the workpieces are machined on the circumferential surface towards the axis of rotation and, in the case of hollow parts, away from the axis of rotation.

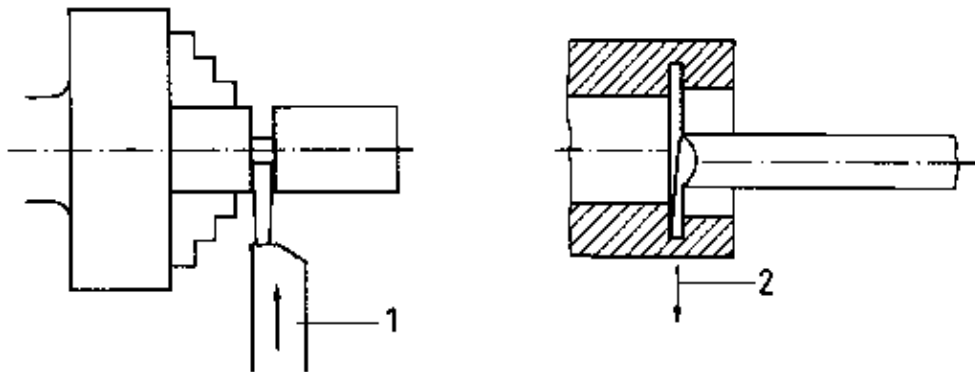

Figure 10 Direction of machining when recessing

1 circumferential surface – towards axis of rotation

2 hollow part – away from axis of rotation

– The part is held in a chuck and for external grooves a live centre is used as counter-support.

– The recess in the circumferential surface is turned by a straight right-hand end-cut turning tool or hook tool.

– The workpiece is to be clamped in internally turned chuck jaws to guarantee true running of the workpiece and prevent damage to the surface at the points of contact.

– The width of the recess is produced in one operation provided that the end-cut turning tool or hook tool has the exact width.

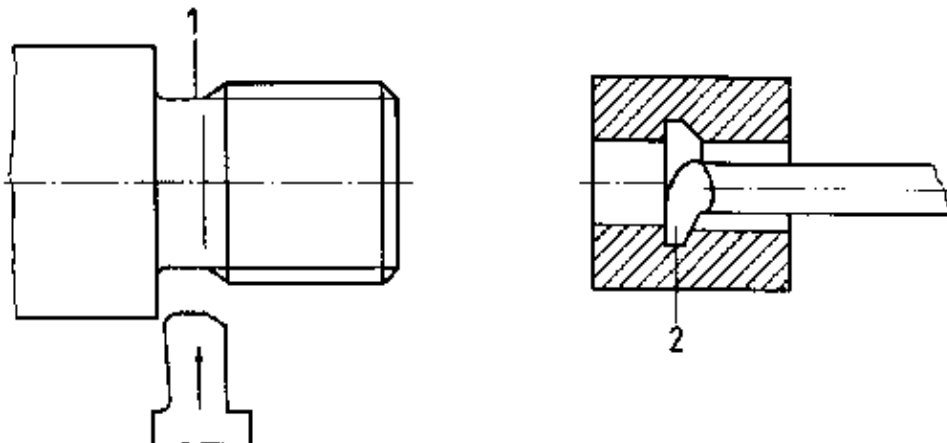

Figure 11 Width of recess in one operation

- 1 recessing in the circumferential surface
- 2 recessing in hollow parts

- When recessing thread grooves, grinding of the 60° taper for the thread runout can be done at the same time.
- The exact width of the end-cut turning tool necessitates exact sharpening but guarantees dimensional consistency for many parts and is economical.
- To avoid vibrations, the workpiece and end-cut turning tool or hook tool should be clamped as short as possible.
- To ensure proper quality, stop and block gauge should be used.

Due to the rotation of the workpiece to be machined, the diameter of the workpiece is doubled by the amount of feed setting.

Do not do any measuring or testing unless the machine is at rest!

What is to be considered when grinding the round corner for the chips to roll off?

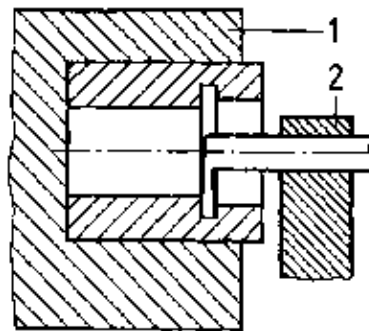

Figure 12 Safe clamping of workpiece and tool

- 1 clamping of workpiece
- 2 clamping of turning tool

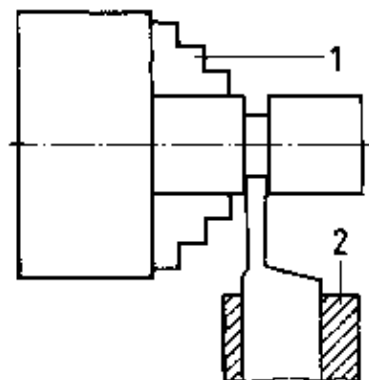

Figure 13 Safe clamping of workpiece and tool

- 1 clamping of workpiece
- 2 clamping of turning tool

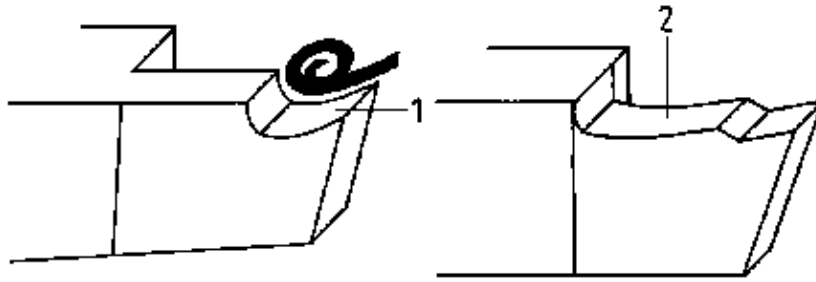

Figure 14 Round (concave) corner for the chips to roll off at the end-cut turning tool

- 1 unfavourable grind,
- 2 correct grind

For dimensional checks retract the hook tool sufficiently and cover it by a rag to prevent accidents.

5. Cutting-out of disks and rings

The cutting-out technique involves machining of the workpieces on their end faces and is used for specific jobs. The turning tool is moved in axial direction. The right-hand end-cut turning tool, specially ground, is mostly used (see Fig. 4 – relief-grinding of the secondary cutting edge to avoid "dragging" of the tool).

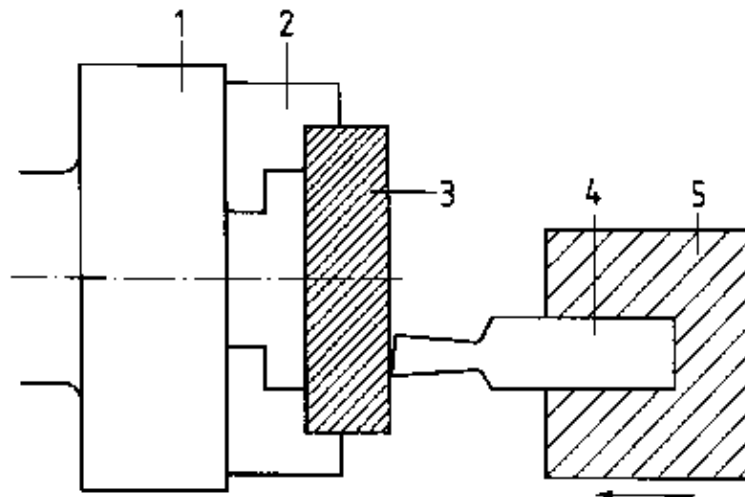

Figure 15 Working direction when cutting-out

- 1 three-jaw chuck,
- 2 soft chuck jaws,
- 3 workpiece,
- 4 end-cut turning tool,
- 5 turning tool holder

- The workpiece is chucked in a chuck.
- The workpiece is held in internally turned chuck jaws.
- Stop and block gauge are used to avoid cutting-through and, consequently, tool breakage.
- Cutting-out is completed 0.1 – 0.2 mm before breaking-through and after unloading the cut-out part is knocked out by hammer blows to avoid tool breakage and prevent accidents.

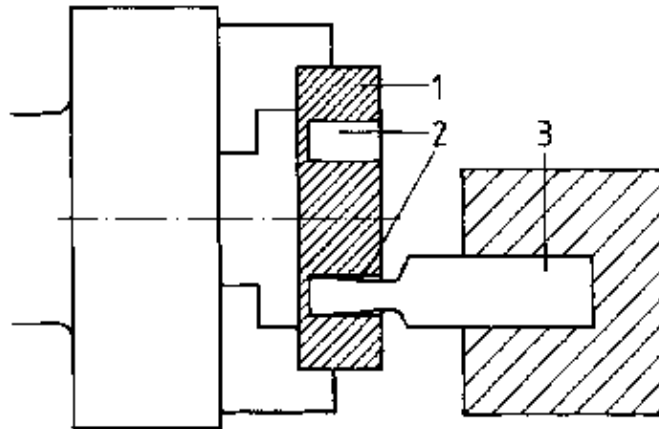

Figure 16 Completion of cutting-out before breaking-through

- 1 workpiece,
- 2 cutting-out depth 0.1 – 0.2 mm before breaking through,
- 3 end-cut turning tool

– Cutting-out of very long workplaces can be done from two ends to add up to the stability of the turning tool.

Which measuring and testing tools are used for cutting-out?

6. Cutting-off of solid stock and hollow parts

The cutting-off technique involves machining of the workpieces on the circumferential surface towards the axis of rotation until the workpiece is parted.

The right-hand end-cut turning tool is mostly used.

The cutting-off technique as metal-cutting operation is a highly economical way of parting workpieces.

- The parts to be machined are held in a chuck in hard chuck jaws.
- When cutting-off into solid stock, the turning tool works under similar conditions as with facing of a disk, i.e. the diameter is reduced and, with constant rotational speed, the cutting speed is reduced, too.

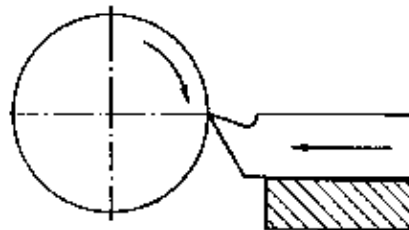

Figure 17 Facing of a disk

With constant rotational speed – reduction in diameter – cutting speed approaching 0.

- With the turning tool approaching the centre, the cutting speed is approaching the value zero.
- The spindle bearing of the lathe must be free from play to avoid hooking and breakage of the turning tool.

– The primary cutting edge of the end-cut turning tool is to be ground slightly obliquely so that no parting-off flash will be left on the cut-off part. (Fig. 5 in section 2).

Machinist 1st Year – Transparencies

Table of Contents

<u>Machinist 1st Year – Transparencies</u>	1
<u>Vernier caliper Parts and Principle – TR 01 02 01 01 98</u>	1
<u>Reading of Vernier Caliper – TR 01 02 01 02 98</u>	1
<u>Reading of Vernier Caliper (Assignments) – TR 01 02 01 03 98</u>	2
<u>Micrometer parts and graduations – TR 01 02 02 01 98</u>	3
<u>Reading of Micrometer (Outside) – TR 01 02 02 02 98</u>	3
<u>Vernier Bevel Protractor parts and principle – TR 01 02 03 01 98</u>	4
<u>Vernier Bevel Protractor (Reading) – TR 01 02 03 02 98</u>	5
<u>Vernier Bevel Protractor (Applications) – TR 01 02 03 03 98</u>	7
<u>Depth Micrometer Parts and Reading – TR 01 02 06 01 98</u>	7
<u>Cutting speed, R.P.M. and Feed of drills – TR 01 05 01 01 98</u>	8
<u>Limits and Fits – Terminology – TR 01 06 01 01 98</u>	10
<u>Method of indicating surface roughness – TR 01 02 12 01 98</u>	10
<u>Classes of fits – TR 01 06 01 03 98</u>	12
<u>Basic shaft system (Shaft basis) – TR 01 06 01 04 98</u>	13
<u>Basic Hole System (Hole basis) – TR 01 06 01 05 98</u>	15
<u>Lathe parts and function – TR 01 12 01 01 98</u>	16
<u>Quick return motion of shaper – TR 01 16 02 01 98</u>	17
<u>Feed mechanism of a shaper – TR 01 16 03 01 98</u>	18
<u>Hydraulic Shaper Mechanism – TR 01 16 06 01 98</u>	18
<u>Relationship of Helix angle & force acting – TR 01 19 02 01 98</u>	20
<u>Up milling and Down milling – TR 01 19 04 01 98</u>	21
<u>Dividing Head Parts and Functions – TR 01 19 05 01 98</u>	22
<u>Elements of a Spur Gear I – TR 01 20 02 01 98</u>	22
<u>Elements of a Spur Gear II – TR 01 20 02 02 98</u>	23
<u>Gear Tooth Vernier Caliper & its Application – TR 01 20 03 01 98</u>	25

Machinist 1st Year – Transparencies



Directorate General of
Employment and Training
Ministry of Labour, Govt. of India

Deutsche Gesellschaft für Technische
Zusammenarbeit (GTZ), GmbH
German Technical Co-operation



Developed by

CENTRAL INSTRUCTIONAL MEDIA INSTITUTE

P.O. Box. 3124, 76, GST Road, Guindy, Chennai – 600 032. Phone: 234 5256, 234 5257. Fax: (0091-44) 234 2791

Vernier caliper Parts and Principle – TR 01 02 01 01 98

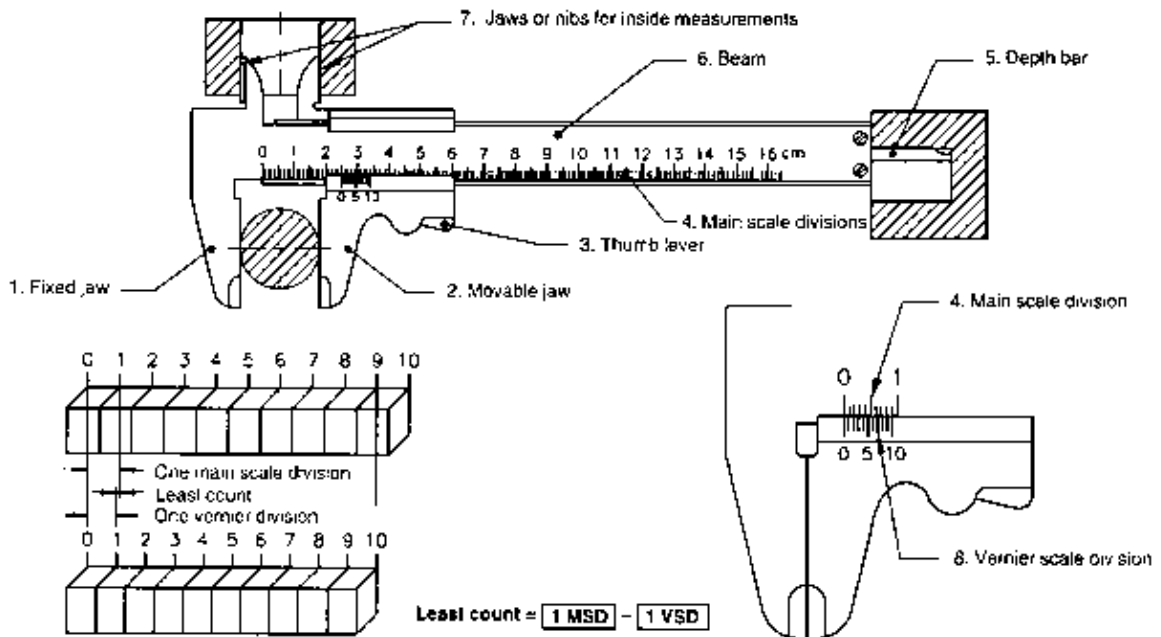

Reading of Vernier Caliper – TR 01 02 01 02 98

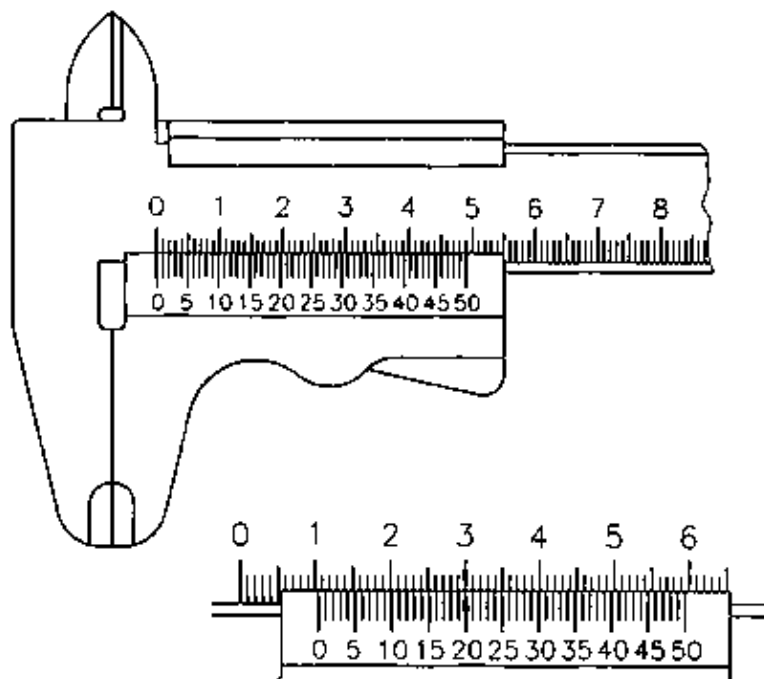

49 Main scale divisions are divided into 50 vernier scale divisions

Value of 1 VSD $= \frac{49}{50} mm$

Least count $= 1 \text{ MSD} - 1 \text{ VSD}$
 $= 1 - \frac{49}{50}$
 $= \frac{1}{50} = 0.02 mm$

Main scale reading $= 10.00 mm$

No of VSD coinciding with MSD $= 20$

Value of coinciding vernier division $= 00.40 mm$

Reading $= \text{MS Reading} + \text{VS Reading}$
 $= 10.00 + 0.40 mm$
 $= 10.40 mm$

Reading of Vernier Caliper (Assignments) – TR 01 02 01 03 98

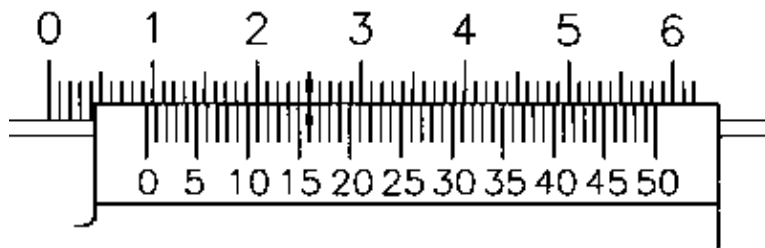

Main scale reading $= 9.00 mm$

Value of coinciding vernier division $= 0.32 mm$

Reading $= 9.32 mm$

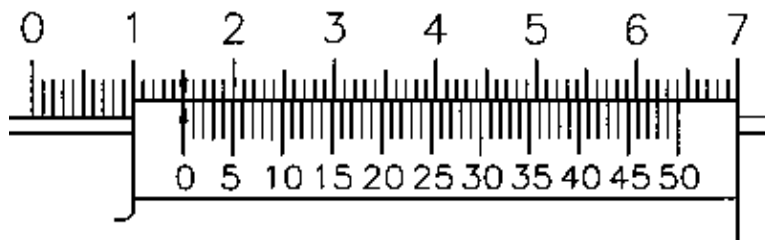

Main scale reading $= 15.00 mm$

Value of coinciding vernier division $= 0 mm$

Reading $= 15.00 mm$

Micrometer parts and graduations – TR 01 02 02 01 98

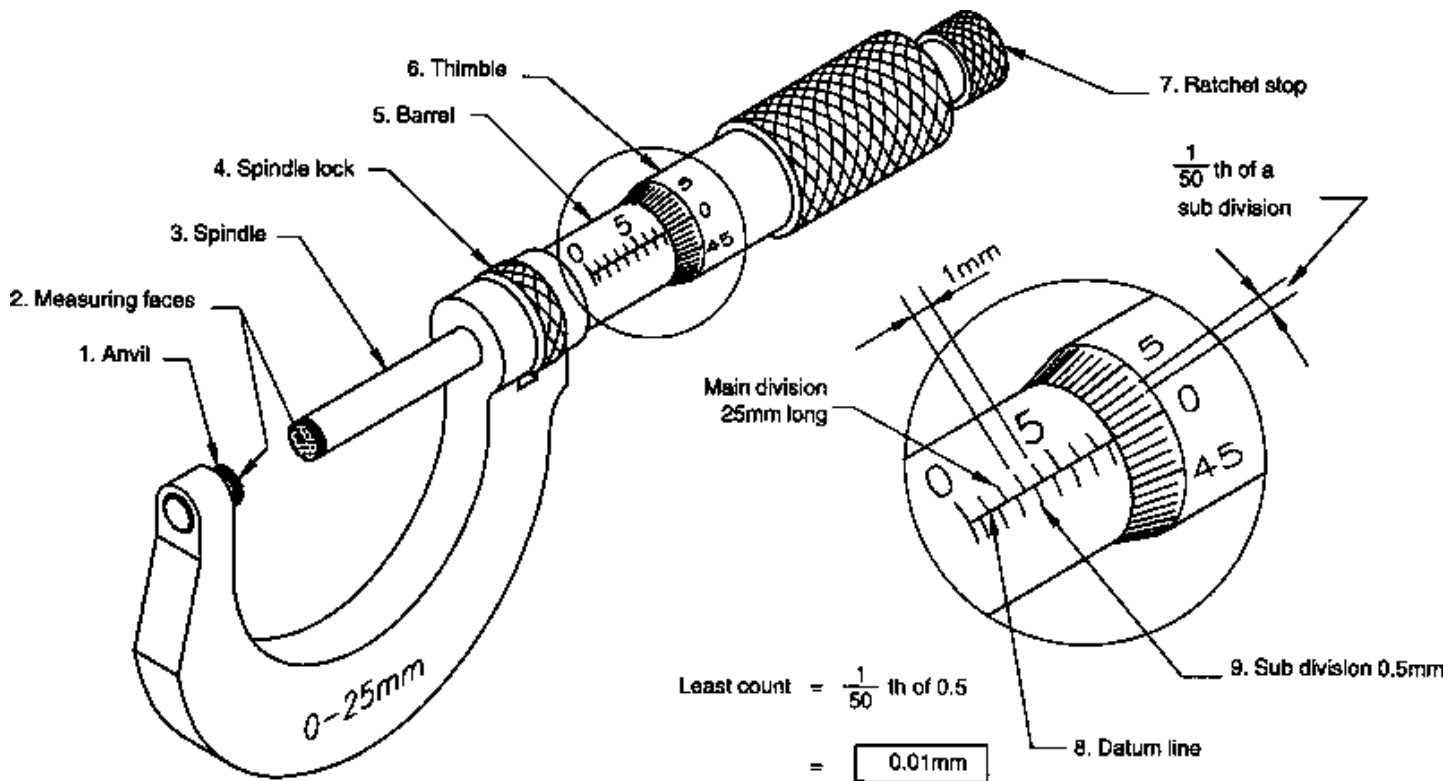

The range of the Micrometer is 0 – 25 mm.

Reading of Micrometer (Outside) – TR 01 02 02 02 98

Main divisions
2 x 1mm = 2.00 mm

Thimble divisions
25 x 0.01mm = 0.25 mm

Sub division
0 x 0.5mm = 0.5 mm

Main divisions	= 2 x 1 mm	2.00 mm
Sub division	= 1 x 0.50 mm	0.50 mm
Thimble divisions	= 25 x .01 mm	

0.25
mm

Reading = 2.75
mm

EXAMPLE

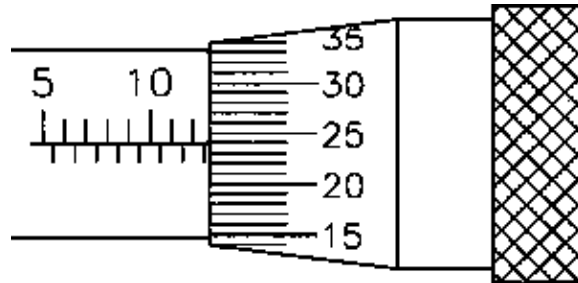

Main divisions = $12 \times 1 \text{ mm}$ = 12.00
mm

Sub division = $1 \times 0.50 \text{ mm}$ = 0.50
mm

Thimble divisions = $24 \times 0.01 \text{ mm}$ = 0.24
mm

Reading = 12.74
mm

Vernier Bevel Protractor parts and principle – TR 01 02 03 01 98

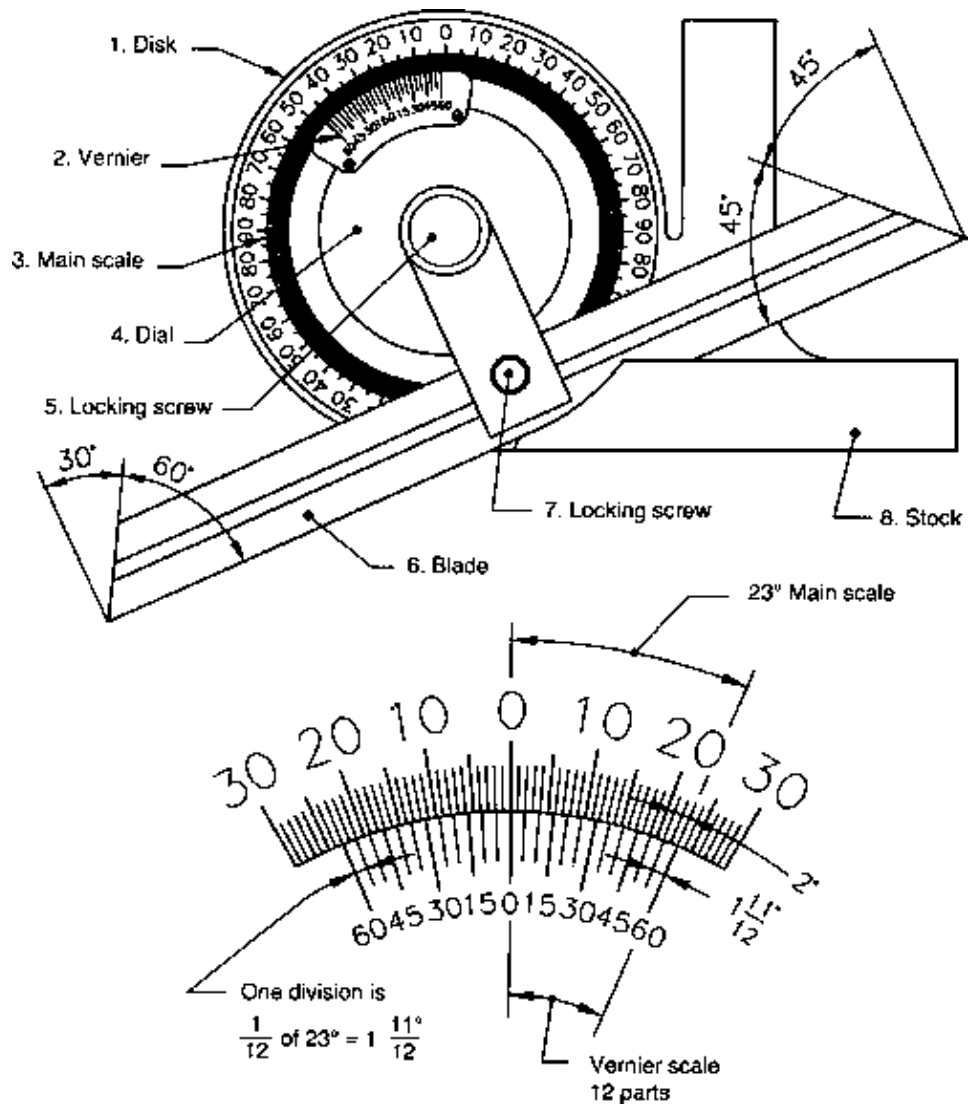

The full circumference of the disk is graduated into 360 equal parts.

The value of each division on the disk is = 1° (Main scale division)

23° of the main scale division is divided into 12 equal parts on the vernier scale.

The value of each vernier scale division is $= \frac{23^\circ}{12}$ or $1^\circ 55'$

Least count is $= 2^\circ - \frac{23^\circ}{12} = \frac{1^\circ}{12}$ or 5'

Note: Value of one VSD ($1^\circ 55'$) is more than 1° (MSD). Hence 2 MSD (2°) are taken

Vernier Bevel Protractor (Reading) – TR 01 02 03 02 98

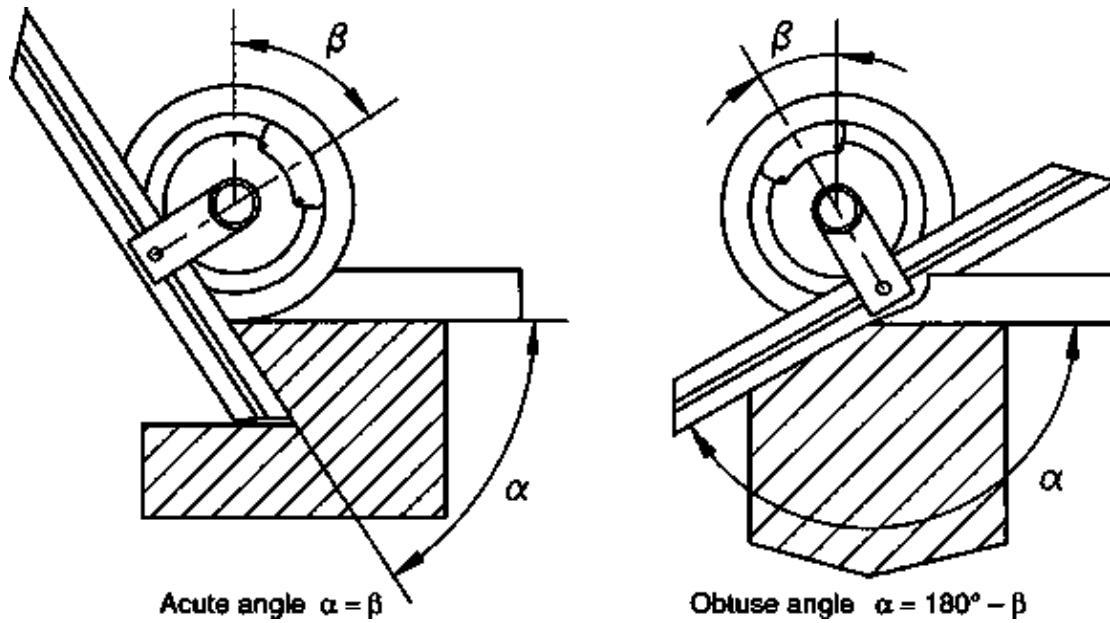

ASSIGNMENTS



MSD = 54°
 Value of VSD = $25'$
 Reading = $54^\circ 25'$



MSD = 60°
 Value of VSD = $55'$
 ? = $180^\circ - 60^\circ 55'$
 Reading = $119^\circ 5'$



MSD = 29°
 Value of VSD = 10'
 Reading = 29° 10'



MSD = 30°
 Value of VSD = 35'
 Reading = 30° 35'

Vernier Bevel Protractor (Applications) – TR 01 02 03 03 98

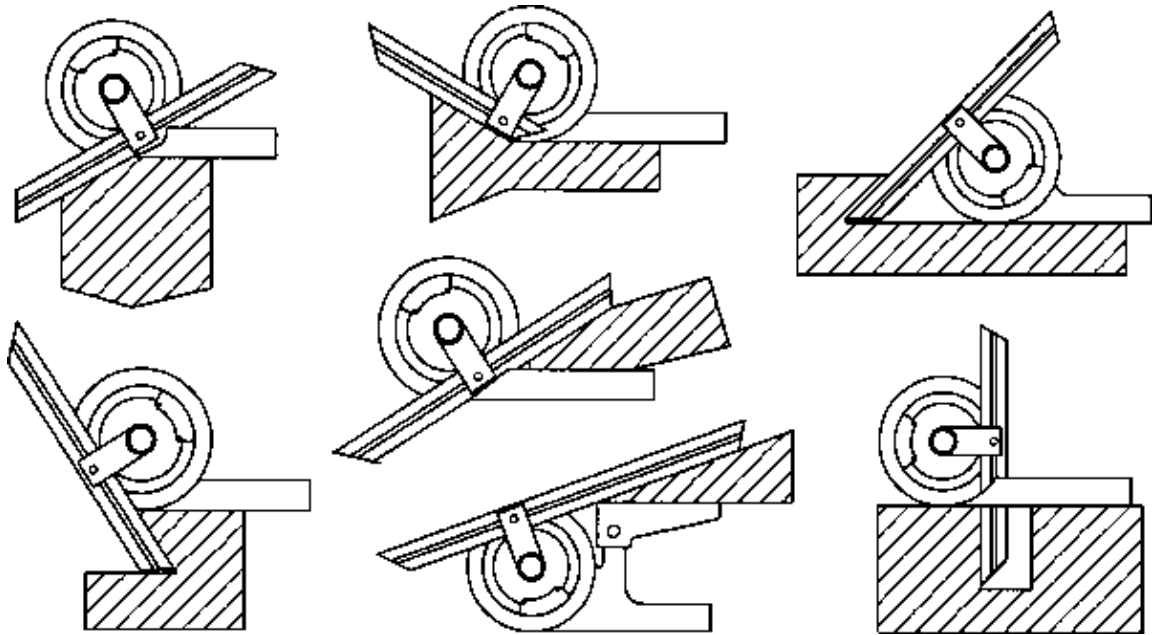

Depth Micrometer Parts and Reading – TR 01 02 06 01 98

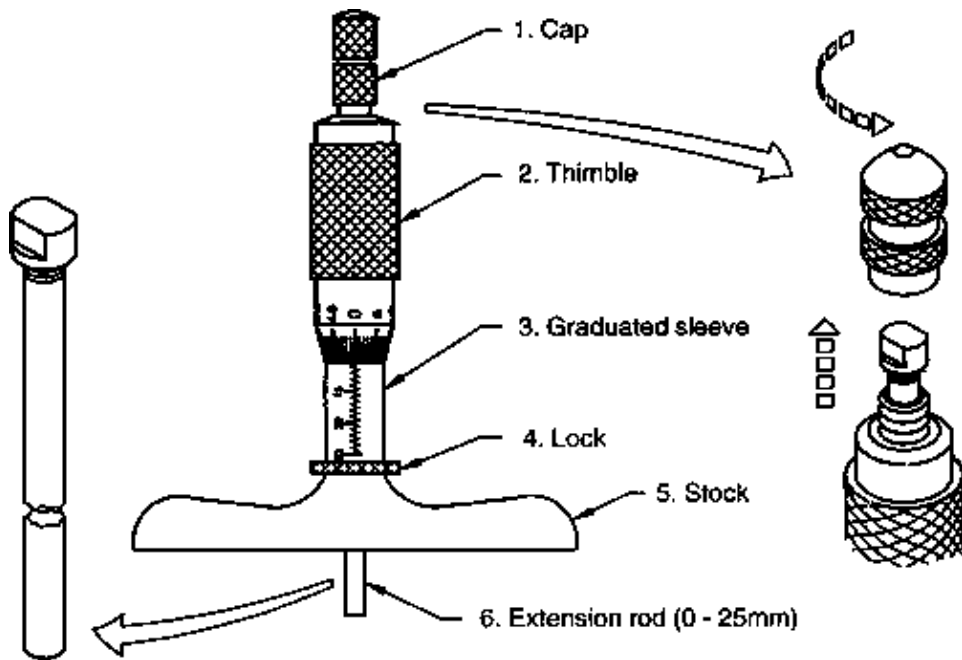

The extension rod face flushes with the stock when zero of thimble coincides with the zero of sleeve

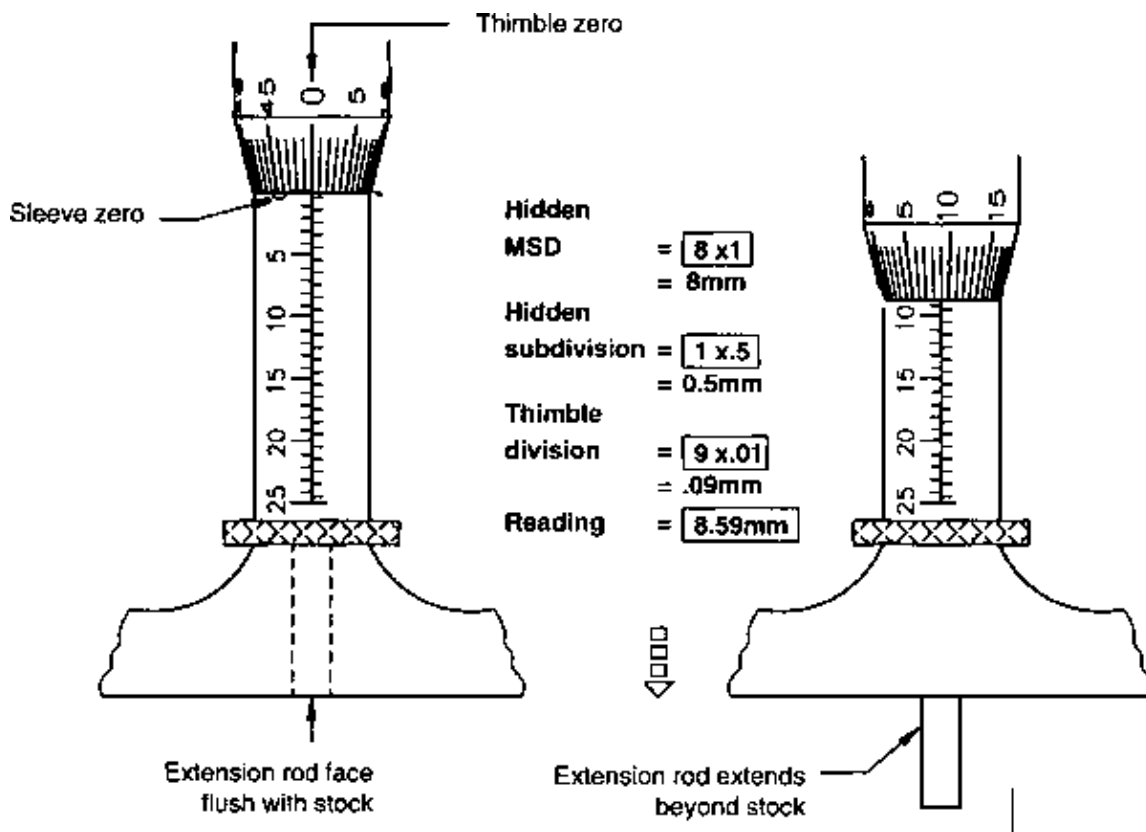

Cutting speed, R.P.M. and Feed of drills – TR 01 05 01 01 98

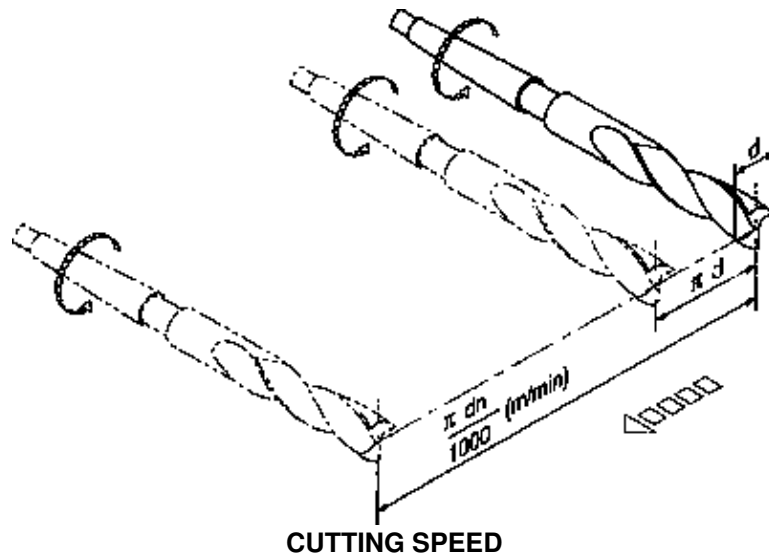

The cutting speed for drilling is the speed of the periphery of the cutting edge in m/min.

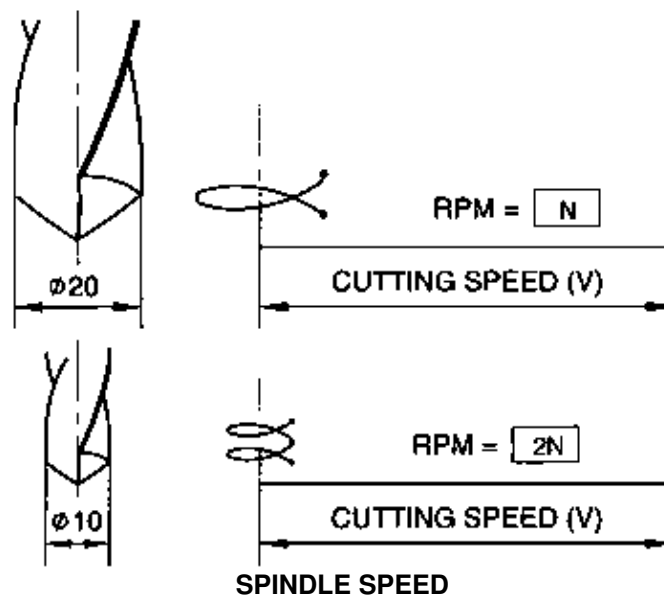

The RPM of the drill depends on the cutting speed and diameter of the drill.

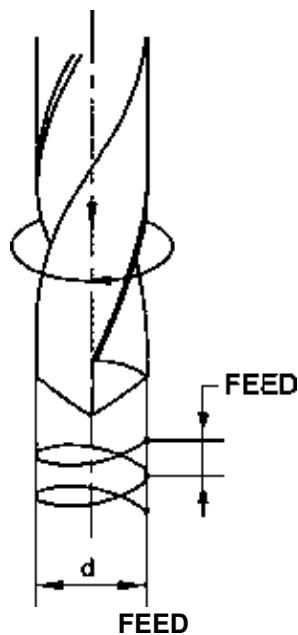

Feed is the distance that a drill advances into the work for each revolution.

Limits and Fits – Terminology – TR 01 06 01 01 98

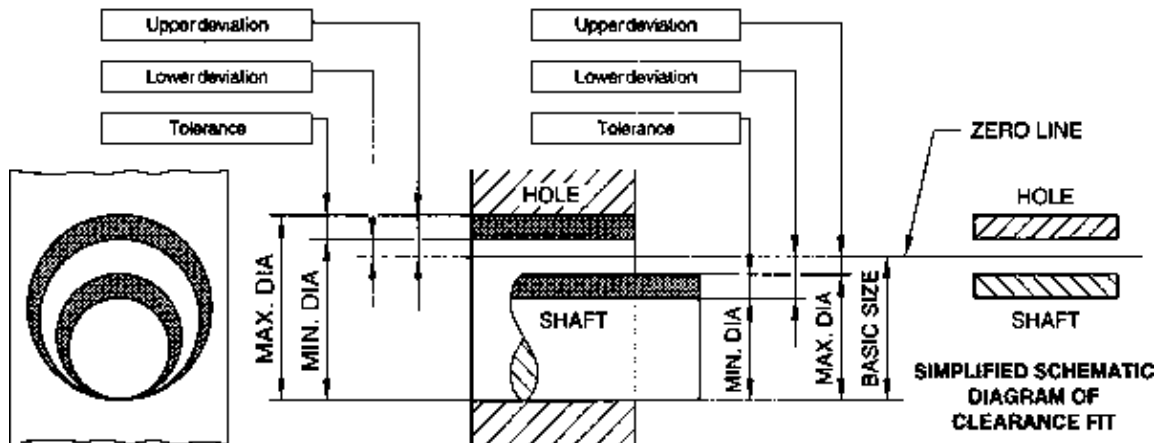

- The zero line is the line of zero deviation and represents the Basic size.
- The deviation which gives maximum limit of size is called Upper deviation.
- The deviation which gives minimum limit of size is called Lower deviation.
- By convention, when the zero line is drawn horizontally Positive deviations are shown above and Negative deviations are shown below it.

Method of indicating surface roughness – TR 01 02 12 01 98

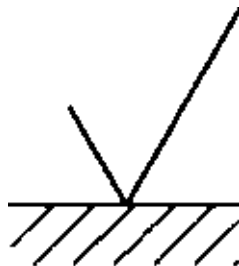

This is the basic symbol and has no meaning as it is.

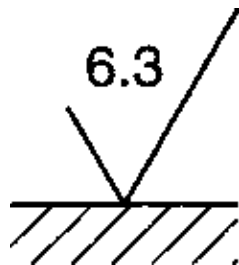

Should be followed by roughness value.

The roughness value may be obtained by any process

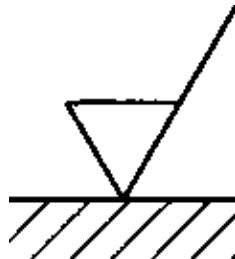

Removal of material is by machining only.

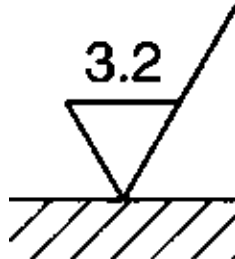

Should be followed by roughness value.

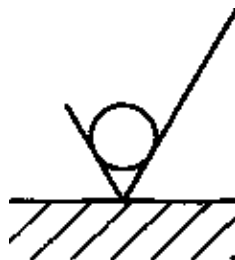

Removal of material is prohibited.

Surface finish is obtained by process (eg.) electroplating, burnishing, lapping etc.

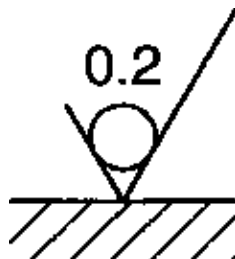

Roughness value must be obtained without removal of material.

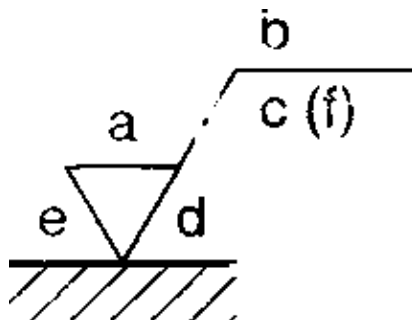

- a = Roughness value R_a in micrometer or roughness grade number N1 to N2.
- b = Production method, Treatment or coating
- c = Sampling length,
- d = direction of lay.
- e = Machining allowance
- f = Other roughness value (in bracket)

EXAMPLE

∇ N7 / all over
except where otherwise stated

OR

∇ N7 / (∇ N3 / ∇ N5)

OR

∇ N7 / (\checkmark)

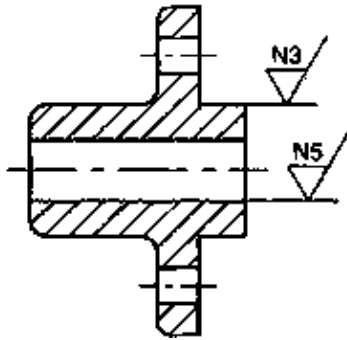

The surface roughness is indicated as follows:

– The notation “except where otherwise stated”

or

– The symbol or symbols of roughness which are exceptional to the general symbol are indicated on the corresponding surfaces.

or

– a basic symbol (in bracket) where otherwise stated.

Classes of fits – TR 01 06 01 03 98

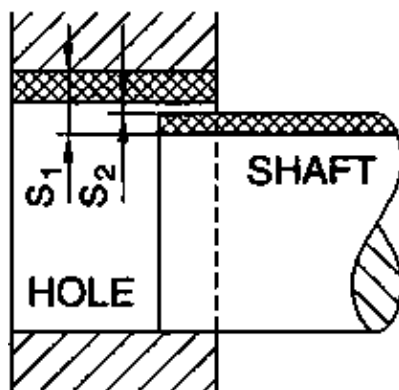

**SIMPLIFIED
REPRESENTATION**

CLEARANCE FIT

S_1 = Maximum Clearance

S_2 = Minimum Clearance

In a clearance fit the tolerance zone of hole will be always above the tolerance zone of shaft.

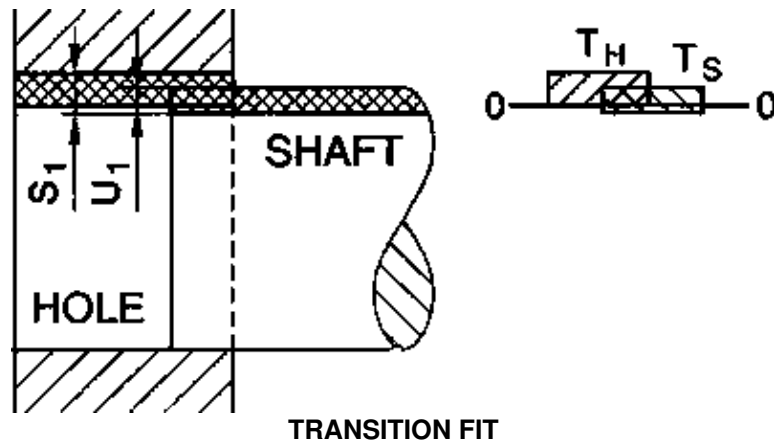

$S_1 =$ Maximum Clearance
 $U_1 =$ Maximum Interference

In a transition fit the tolerance zone of hole and tolerance zone of shaft will overlap.

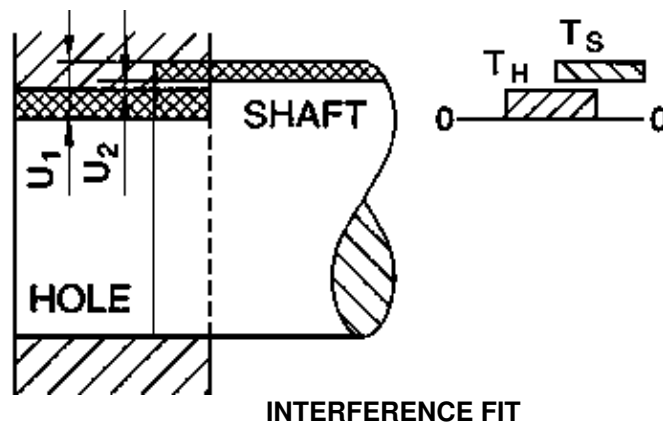

$U_1 =$ Maximum Interference
 $U_2 =$ Minimum Interference

In an interference fit the tolerance zone of hole will be always below the tolerance zone of shaft.

Basic shaft system (Shaft basis) – TR 01 06 01 04 98

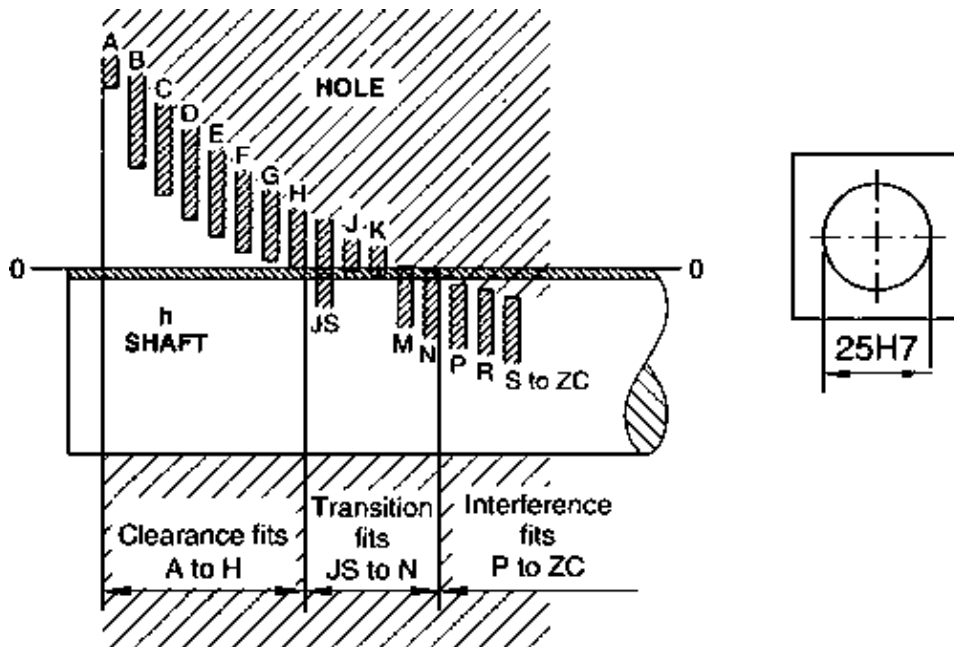

Capital letters A to ZC indicate 25 fundamental deviations for holes.

(A,B,C,D,E,F,G,H,JS,J,K,M,N,O,P,R,S,T,U,V,X,Y,Z,ZA,ZB,ZC) There are 18 grades of tolerances. (01,0,1....16)

- 25 mm is basic size
- 'H' is the fundamental deviation for hole
- '7' is the grade of tolerance

APPLICATION

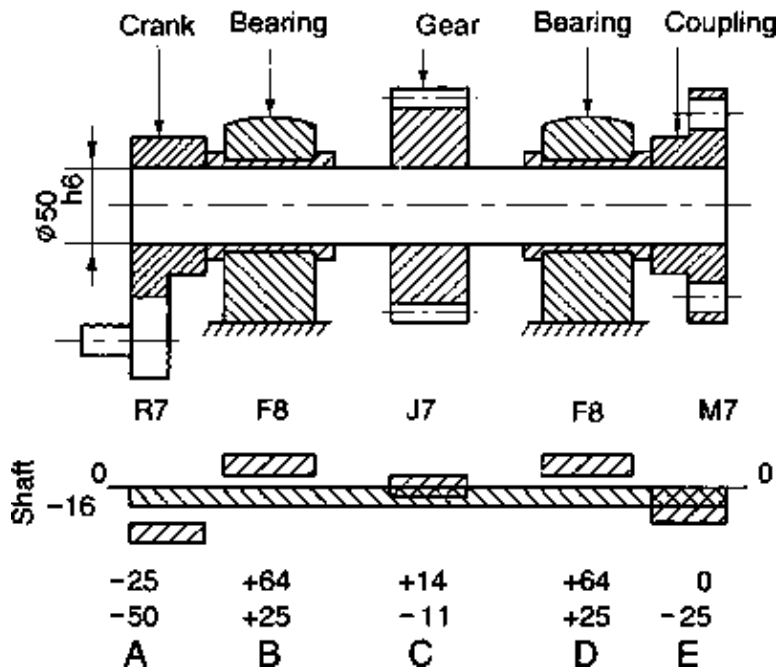

What is shaft basic system?

Different clearances and interferences are obtained in associating various holes with single shaft, whose upper deviation is zero. (symbol 'h')

Name the fit

- A Interference fit
- B Clearance fit
- C Transition fit
- D Clearance fit
- E Transition fit

Basic Hole System (Hole basis) – TR 01 06 01 05 98

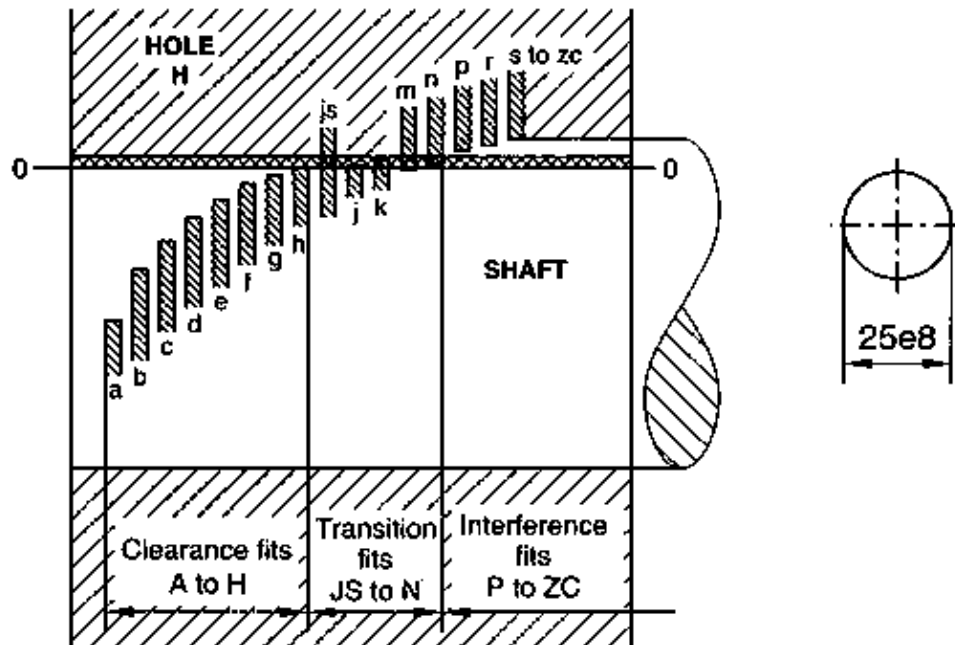

Small letters a to zc indicate 25 fundamental deviations for shafts.

(a,b,c,d,e,f,g,h,js,j,k,m,n,o,p,r,s,t,u,v,x,y,za,zb,zc) There are 18 grades of tolerances. (01,0,1.... 16)

- 25 mm is basic size
- 'e' is the fundamental deviation for shaft
- '8' is the grade of tolerance

APPLICATION

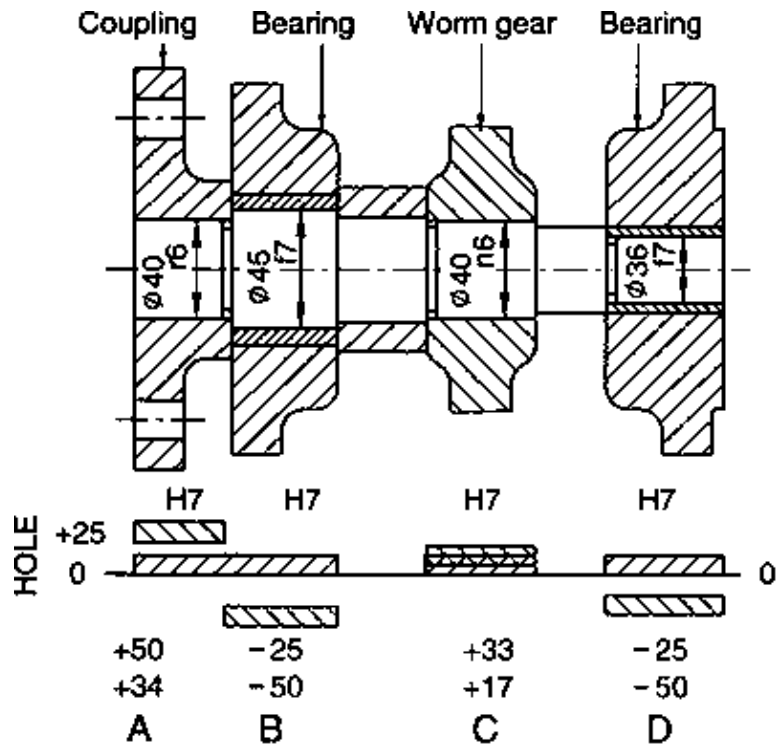

What is hole basic system?

Different clearances and interferences are obtained in associating various shafts with single hole, whose lower deviation is zero. (symbol 'H')

Name the fit

- A Interference fit
- B Clearance fit
- C Transition fit
- D Clearance fit

Lathe parts and function – TR 01 12 01 01 98

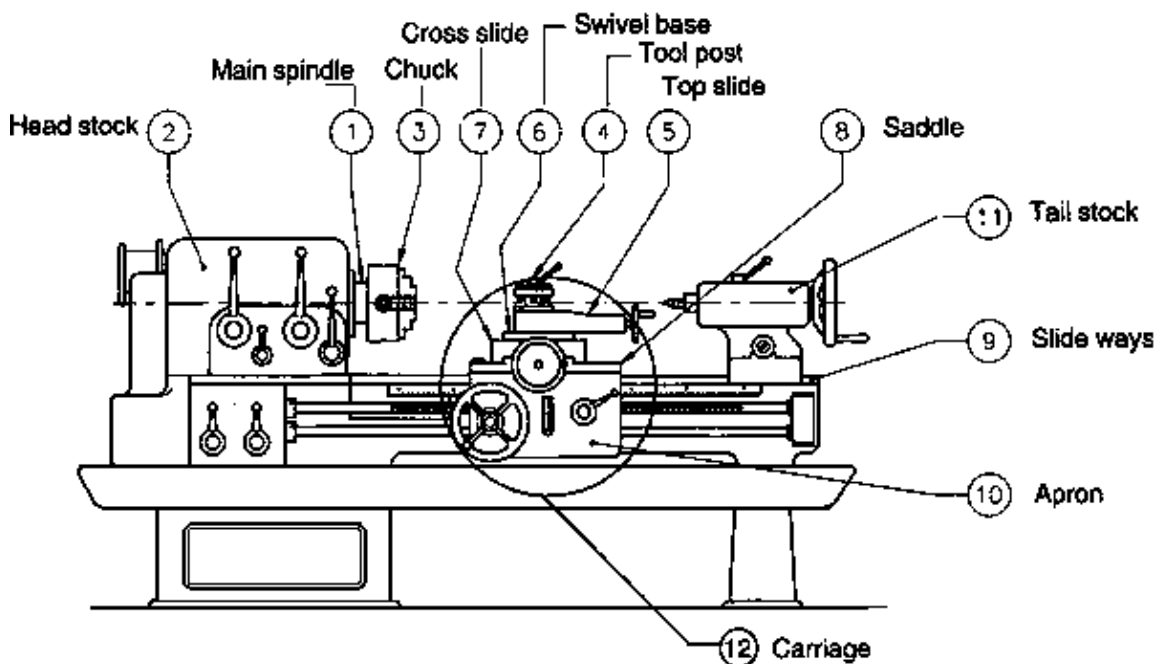

In the HEADSTOCK 2, the MAIN SPINDLE 1 is housed. The main spindle gets the drive from the Electric Motor. The work holding device chuck 3 is fitted at the one end of the main spindle. The TOOL POST 4 is mounted on the TOP SLIDE 5. The slide is fitted on a SWIVEL BASE 6. This helps to position or move the tool at any angle. The swivel base is assembled on the top of the CROSS SLIDE 7. The Cross Slide helps to move the tool perpendicular to the axis of the main spindle. The Cross slide is fixed on the SADDLE 8 which can be moved on the SLIDEWAYS of the bed 9. The CARRIAGE 12 consists of the APRON 10 which causes the feed control devices and all the devices used for tool movement. The TAILSTOCK 11 is mounted on the bed and can slide along the bed. The tailstock is used to support one end of long workpieces with the support of centres, holding cutting tools like drill, reamer and also to shift the axis of workpieces as required for taper turning.

Quick return motion of shaper – TR 01 16 02 01 98

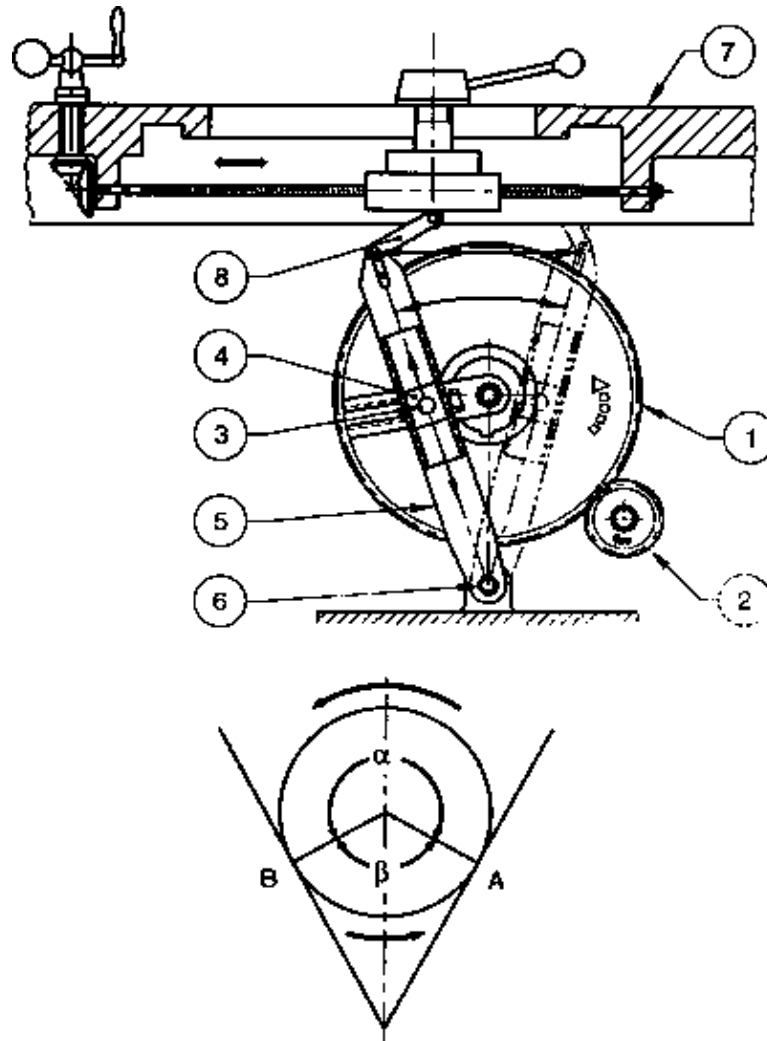

Bull gear (1) is driven by the Pinion (2). The driving Pin (3) rotates with bull gear (1) and carries the sliding block (4). The sliding block slides in the slotted link (5). The slotted link is pivoted (6) at the bottom and connected to ram (7) at the top through a compensating link (8). Through this compensating link (8) lifting of the ram is arrested.

When the bull gear (1) rotates the slotted link (5) oscillates about its pivot (6) providing reciprocating motion to the ram (7).

The driving pin (3) then covers the distance A to B (angle α) during the working stroke and the distance from B to A (angle β) during the return stroke. Angle β is bigger than angle α . Therefore the working stroke takes longer time than the non-cutting stroke. This is useful because during the backward stroke no work is done.

Feed mechanism of a shaper – TR 01 16 03 01 98

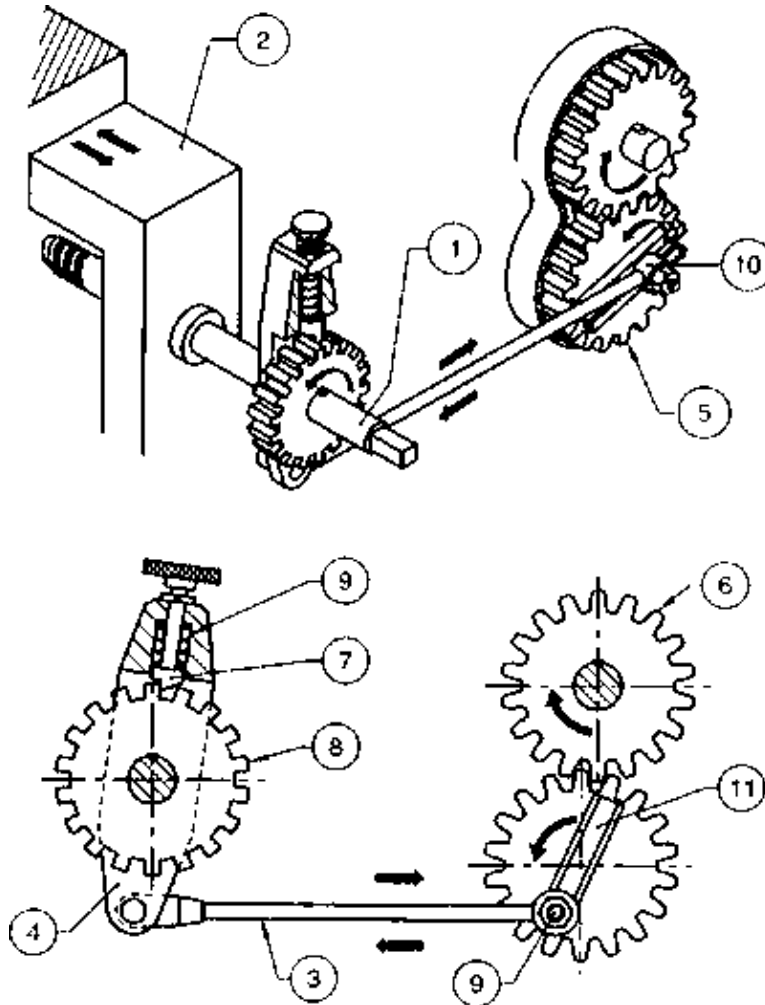

The cross feed screw rod (1) is connected with the table (2). The connecting rod (3) connects the Pawl arm (4) and the crank wheel (5).

As the crank wheel (5) rotates the Pawl arm (4) oscillates around the cross feed screw (1) to and fro. Pawl (7) is pressed on the ratchet wheel (8) by the spring (9).

The Pawl (7) which is spring loaded, is square on one side and bevelled on the other side, so that it rotates the ratchet wheel (8) as it rocks in one direction, but rides over the teeth when it rocks in the other direction. The feed can be obtained in either direction by turning the Pawl (7) through 180°.

The amount of feed can be set by shifting crank pin (9) with sliding block (10) in the crank pin slide (11).

During the manual feed, pawl (7) is pulled up and the pawl is placed in the disengaged position. Manual feed is given by rotating the cross feed screw rod (1) with a handle during the return stroke of the ram.

Hydraulic Shaper Mechanism – TR 01 16 06 01 98

Forward stroke

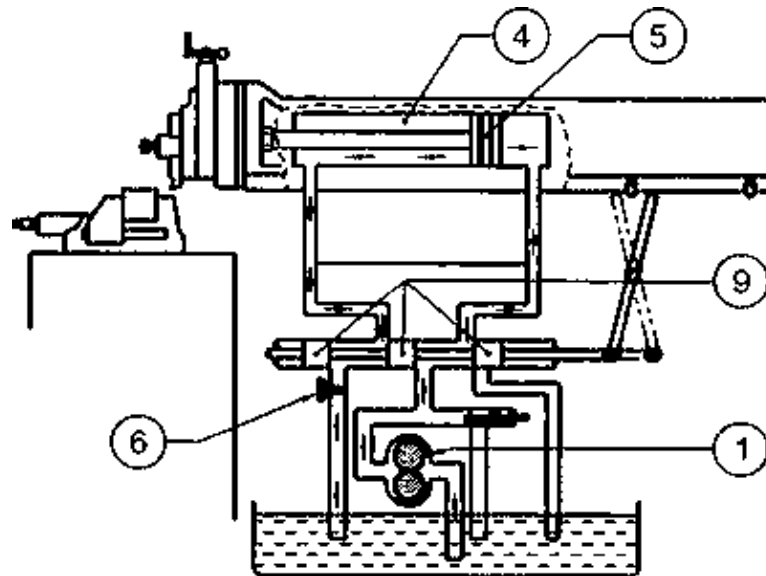

The oil under high pressure due to gear pump (1) is pumped from the reservoir (2). This oil passes through the valve chamber (3) to the right side of the cylinder (4) exerting pressure on the piston (5). This causes the ram to move in forward direction. (Forward stroke)

The oil present on the left side of the cylinder is discharged to the reservoir through the throttle valve (6).

Return stroke

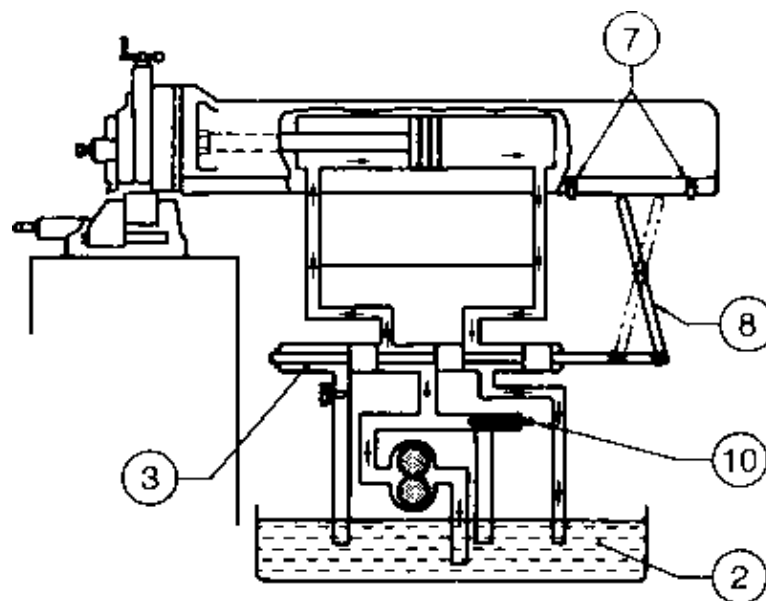

At the end of the forward stroke the reversing dog (7) hits against the reversing lever (8) causing the reversing valves (9) to alter their position within the valve chamber (3). Oil under high pressure is now made to flow to the left side of the piston causing the ram to move back (return stroke).

The oil present on the right side of the piston is now discharged to the reservoir.

This cycle is repeated.

The length and position of stroke can be adjusted by shifting the positions of reversing dogs (7).

The speed of the ram can be varied by controlling the throttle valve (6).

When the throttle valve is partially closed the excess oil flows out through the relief valve (10) to the reservoir (2) maintaining uniform pressure during cutting stroke.

Relationship of Helix angle & force acting – TR 01 19 02 01 98

Milling cutter is LEFT HAND cutting, if seen from the main drive, it runs anti-clockwise and RIGHT-HAND cutting if it runs clockwise.

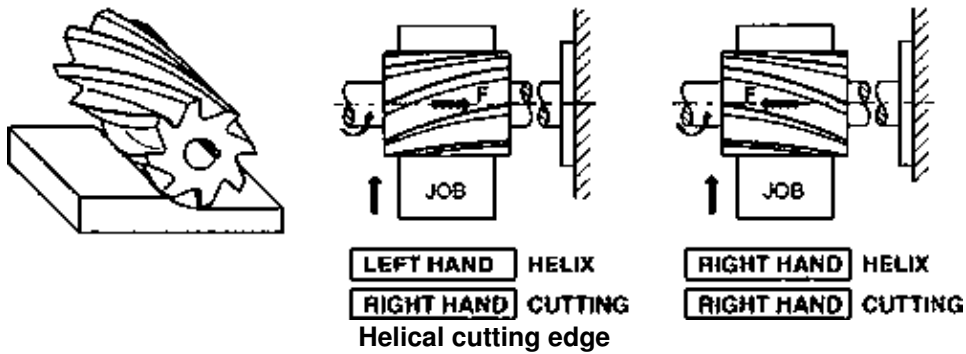

- The teeth make gradual contact
- Several teeth are always in contact simultaneously, so that the cutter runs smoothly and reduces chatter.
- The Chips flow off to the side.

Right hand helix – Left hand cutting Left hand helix – Right hand cutting

- The helix angle generates a force directed along with cutter axis during cutting and a reaction to this force in the workpiece.
- When a cutter has a helix and a cut of the same hand this force will pull the cutter away from the spindle.
- When the helix and cut are of opposite hands the force will press the cutter into the spindle.

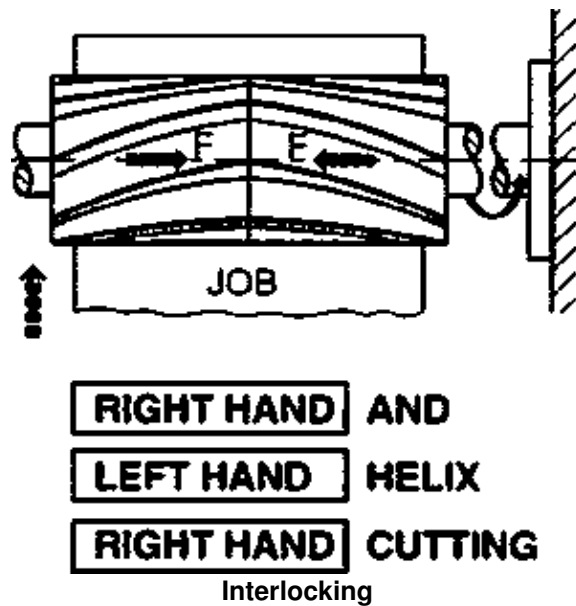

Cylindrical milling cutters with helical teeth directed against each other have the advantage that the axial pressure is partially compensated

Staggered teeth cut with alternate teeth of opposite helix and reduces the risk of chattering.

How the axial pressure is partially compensated?

One cutter has right hand helix with right hand cut. Another cutter has left hand helix with right hand cut. Hence the axial pressure is partially compensated.

Up milling and Down milling – TR 01 19 04 01 98

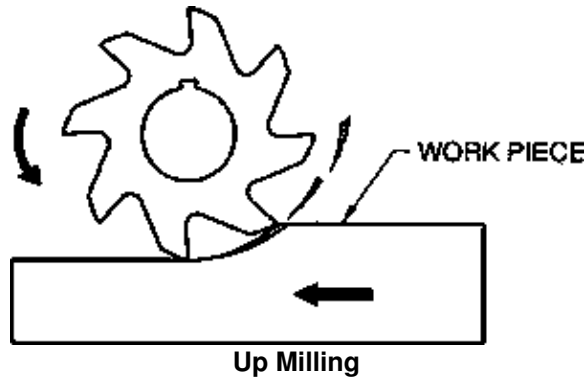

- This is commonly used method.
- Feeding of the workpiece is against the direction of rotation of the cutter.
- Cutting force is maximum at the end of the cut.
- Tool life is shorter due to scraping action of the cutter.
- The workpiece tends to get lifted.
- Used where hard surface layer to be removed.
- Very high quality surface finish is not possible.

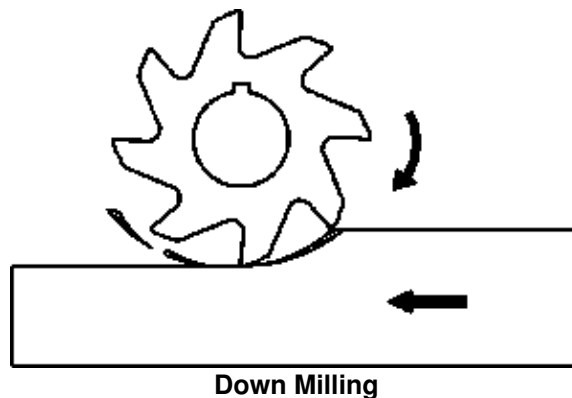

- Feeding of the workpiece is in the same direction of rotation of the cutter.
- Cutting force is heavy at the start of the cut and the cutter tends to climb.
- Play in the table screw and nut causes the table to move more than desired distance when the cutter touches job with maximum force
- Due to this
 - cutter teeth can break
 - the workpiece can be damaged
 - risk of workpiece being pulled
- Recommended only when the machine table is with a backlash eliminator.
- With backlash eliminator higher quality of surface finish is possible.

Dividing Head Parts and Functions – TR 01 19 05 01 98

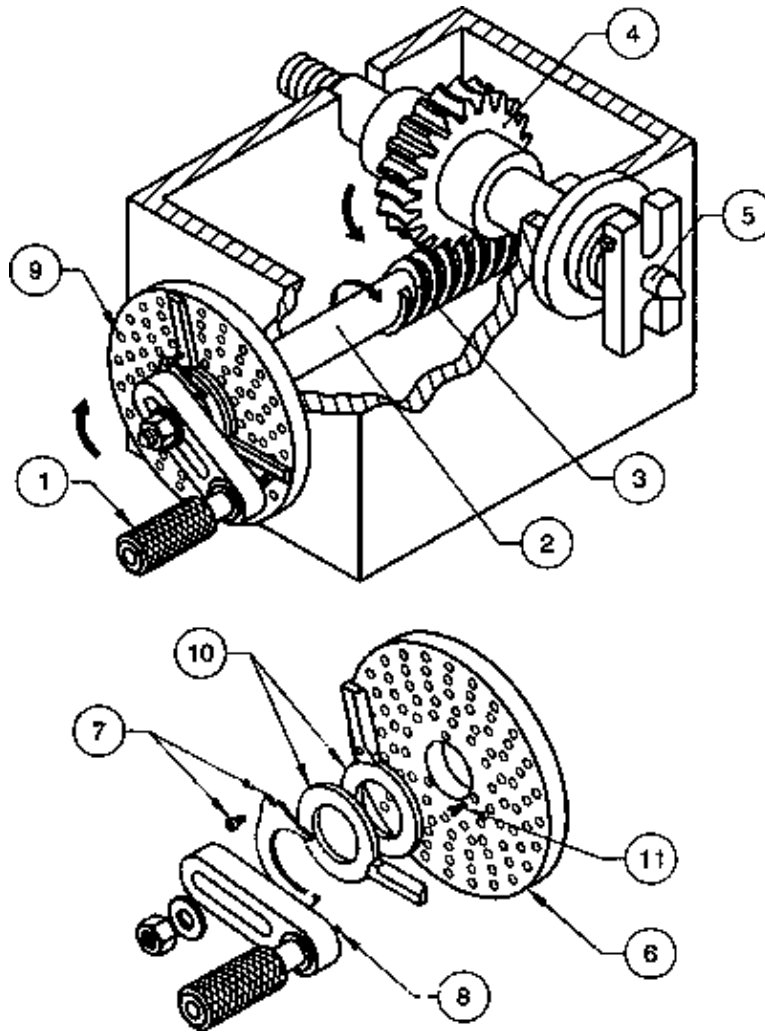

Indexing Mechanism

Dividing head is used for rotating the workpiece to any number of divisions.

The handle (1) rotates the worm shaft (2) along with the worm (3). The worm (3) is engaged with worm wheel (4). For one full rotation of worm shaft (2) the worm wheel (4) moves only by one tooth. The worm wheel (4) has 40 teeth, this makes the ratio between worm (3) and worm wheel (4) 40:1. One end of the worm wheel (4) has provision for fixing the job (5). The handle (1) for turning the worm can be adjusted towards the centre. The interchangeable index plate (6) is fixed by three screws (11) with the housing and the sector arm is connected with the index plate by a spring bolt (7). The handle (1) has plunger pin (8) by means of which the division (9) on index plate is set. The sector arms (10) save the counting of holes while indexing.

Elements of a Spur Gear I – TR 01 20 02 01 98

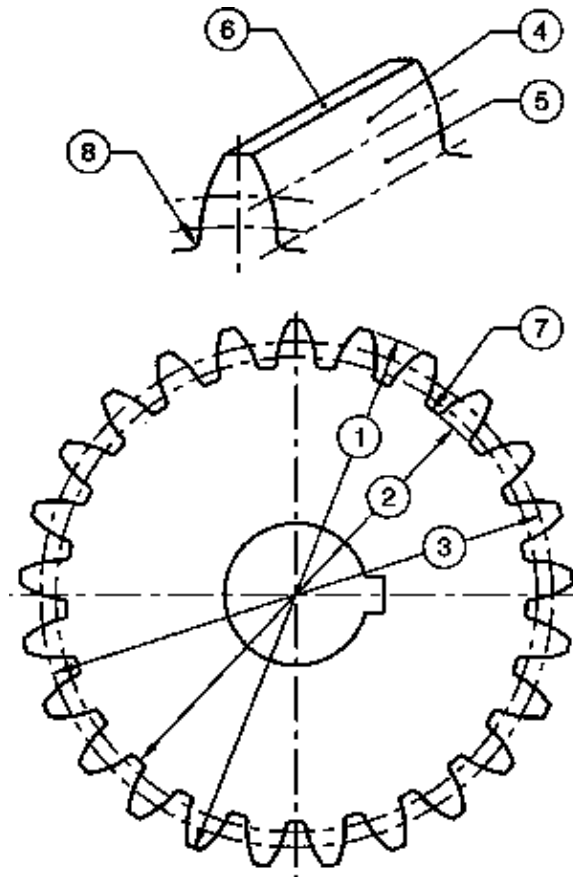

- 1 Outside diameter is the overall diameter of the gear on which the teeth are cut.
- 2 Root diameter is the diameter of the root circle.
- 3 Pitch circle diameter is the diameter of pitch circle.
- 4 Face of tooth is the surface between the pitch line element and the top of the tooth.
- 5 Flank is the surface between pitch line element and bottom of the tooth in includes the fillet.
- 6 Top Land is the surface at the top of the tooth.
- 7 Bottom Land is the surface at the bottom of the tooth space.
- 8 Fillet is the curved surface between the flank and the root surface.

Elements of a Spur Gear II – TR 01 20 02 02 98

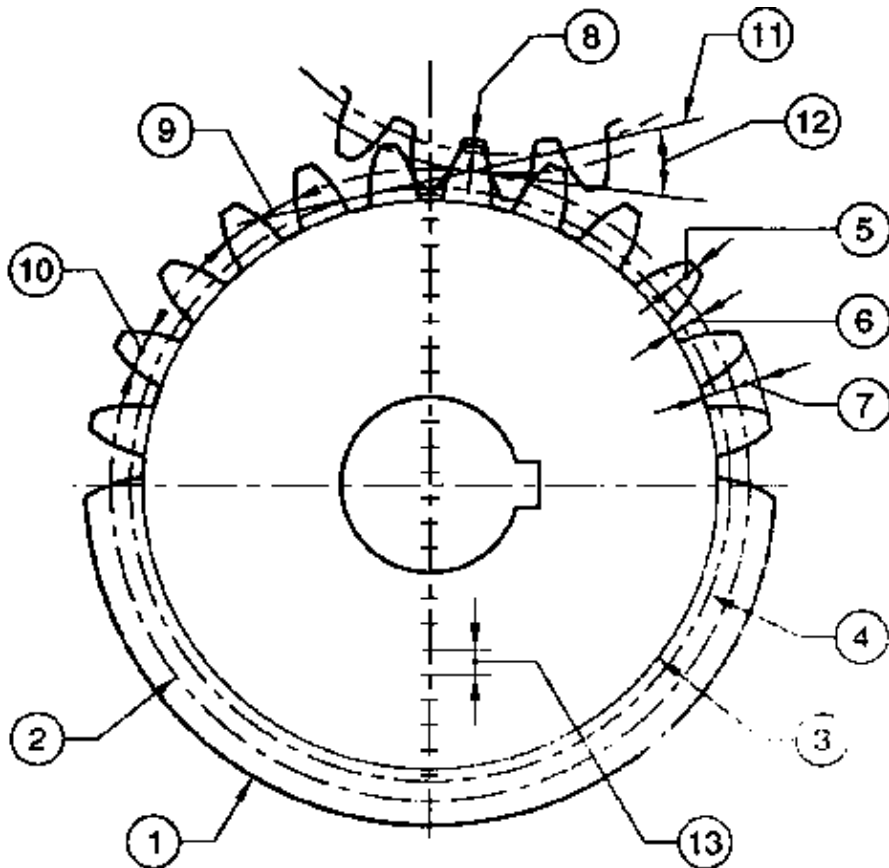

1 Outside circle is the circle formed by the top of the tooth.

2 Pitch circle is the imaginary circle of which two mating gears seems to be rolling.

3 Root circle is the circle formed by the bottoms of the tooth spaces.

4 Base circle is the circle from where the involute is generated.

5 Addendum is the radial distance between pitch circle and the outside circle.

6 Dedendum is the radial distance between pitch circle and the root circle.

7 Tooth depth/Whole depth is the total depth of the tooth ie addendum plus dedendum.

8 Clearance is the radial distance from the top of the tooth to the bottom of the tooth space in the mating gear.

9 Circular pitch is the distance from the point of one tooth to the corresponding point of the adjacent tooth measured on pitch circle.

10 Tooth thickness is the thickness of the tooth measured on the pitch circle.

11 Line of action: The common normal of two mating tooth profiles at their point of contact. Involute gear pairs, the line of action is a fixed straight line, tangent to the two base circle.

12 Pressure angle is the angle formed by a line through the point of contact of two mating teeth and tangent to the two base circles and a line at right angles to the centre line of the gears.

13 Module is defined as the ratio of the pitch circle diameter in millimetre to the number of teeth of a gear.

Gear Tooth Vernier Caliper & its Application – TR 01 20 03 01 98

Corrected Addendum

When measuring gear tooth, it is necessary to set the gear-tooth vernier caliper to the corrected addendum which is a point slightly lower than the true addendum of the gear.

If the Vernier depth slide is set to the true addendum, the caliper will measure the sides of the tooth at a point above the pitch circle and not give a true measurement.

To calculate the gear tooth vernier settings for measuring a gear of 34 teeth 2.5 module.

$$\text{Number of teeth (Z)} = 34$$

$$\text{Module (m)} = 2.5 \text{ mm}$$

$$\begin{aligned} \text{Pitch diameter (pd)} &= Z m \\ &= 34 \times 2.5 \\ &= 85 \end{aligned}$$

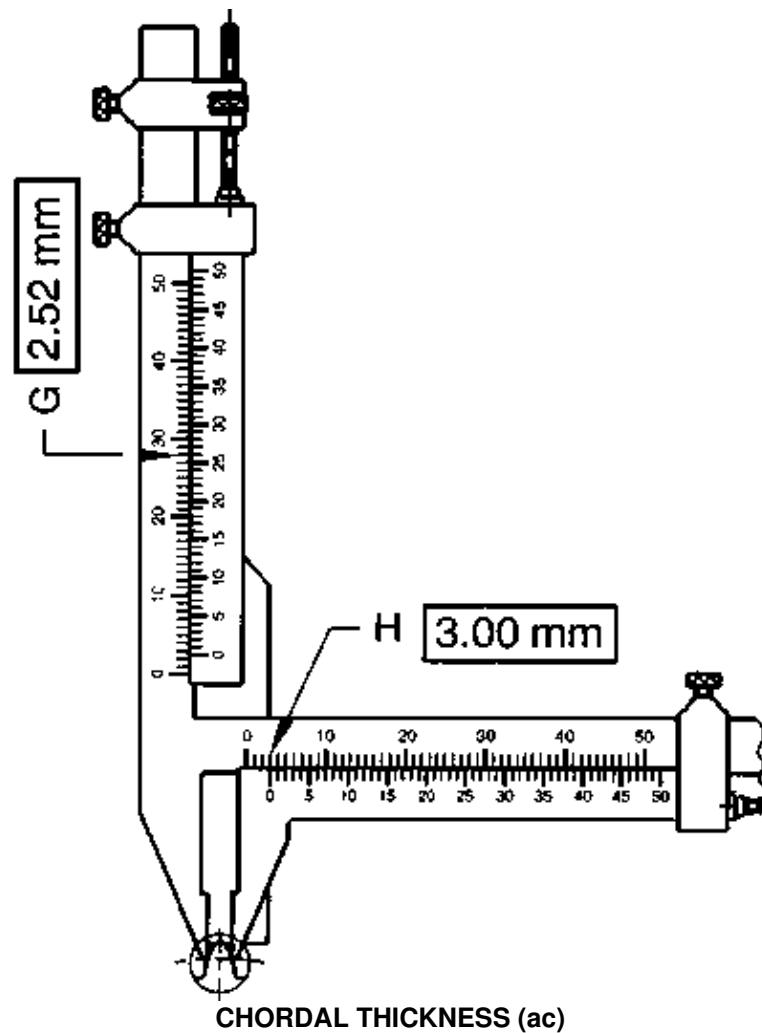

$$= mZ \cdot \sin\left(\frac{90}{Z}\right)$$

$$= 85 \cdot \sin 2.67$$

$$= 85 \times 0.0352$$

$$= \underline{2.992 \text{ mm}}$$

CORRECTED ADDENDUM (hac)

$$= m + \frac{mZ}{2} \left(1 - \cos \frac{90}{Z} \right)$$

$$= 2.5 + \frac{85}{2} (\cos 2,67)$$

$$= 2.5 + 42.5(1 - 0.9994)$$

$$= 2.5 + 42.5 \times 0.0006$$

$$= 2.5 + 0.0255$$

$$= \underline{2.52 \text{ mm}}$$

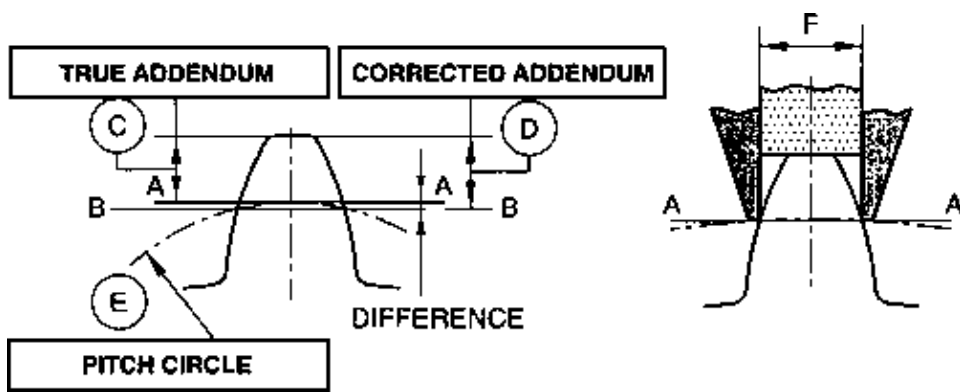

After calculating the corrected addendum and chordal thickness the gear tooth vernier is set to the calculated value and the gear tooth checked.

Machinist 2nd Year – Transparencies

Table of Contents

Machinist 2nd Year – Transparencies	1
Slip Gauges.....	1
Determining slip gauge size.....	2
Special micrometers.....	3
Drill jig.....	5
Fixtures.....	6
Limit plug gauges.....	7
Limit ring and snap gauges.....	9
Shaper stroke length & cutting speed.....	11
Hardness testing – Brinell.....	12
Hardness testing – Vicker.....	14
Hardness testing – Rockwell.....	16
Tool Maker’s Button.....	17
Measurement of screw thread elements – I.....	20
Measurement of screw thread elements – II.....	22
Types of screw thread.....	24
Movements & restraints of work – I.....	27
Movements & restraints of work – II.....	28
Methods of applying lubricant.....	29
Vertical milling machine.....	31
Differential indexing – I.....	32
Differential indexing – II.....	34
Elements of a straight bevel gear.....	36
Surface texture measurement.....	36
Methods of indicating surface roughness.....	38
Worm and worm wheel.....	40

Machinist 2nd Year – Transparencies



CENTRAL INSTRUCTIONAL
MEDIA INSTITUTE, CHENNAI



ANINDO – GERMAN PROJECT

Directorate General of Employment & Training, Ministry of Labour, Govt. Of India

Developed by
CENTRAL INSTITUTIONAL MEDIA INSTITUTE
in collaboration with Deutsche Gesellschaft für Technische Zusammenarbeit (GTZ) Germany

P.O. Box 3142, CTI Campus, Guindy, Chennai – 600 032 Phone: 2233 4248, 2234 5257, Fax: (0091–44) 234 2791

Slip Gauges

TR 01 01 01 01 02

Slip gauges/Gauge blocks are used as standards for length measurement

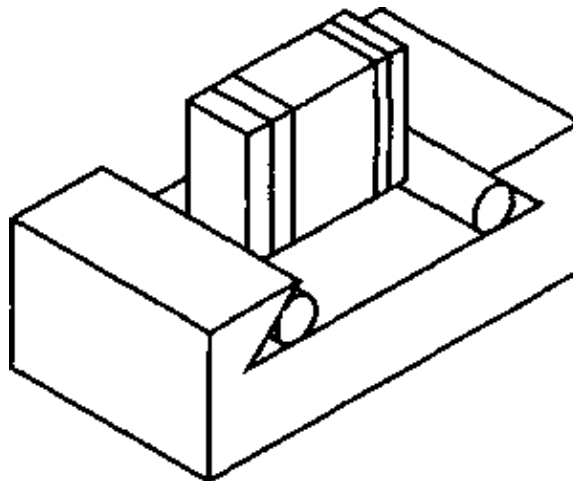

Available in sets with different numbers & different combinations. Eg., 112,103, 78,47,87 pieces etc.

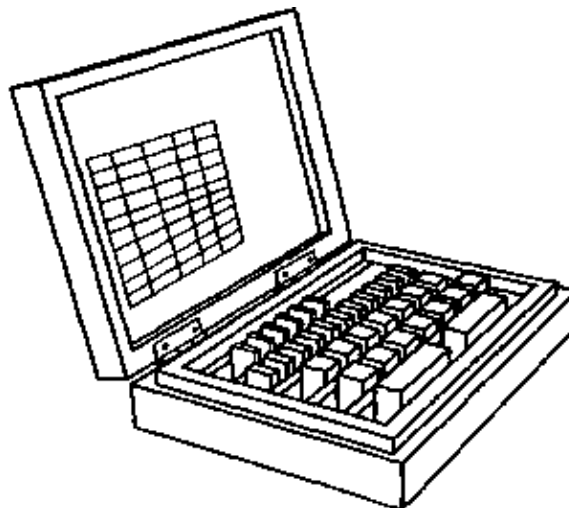

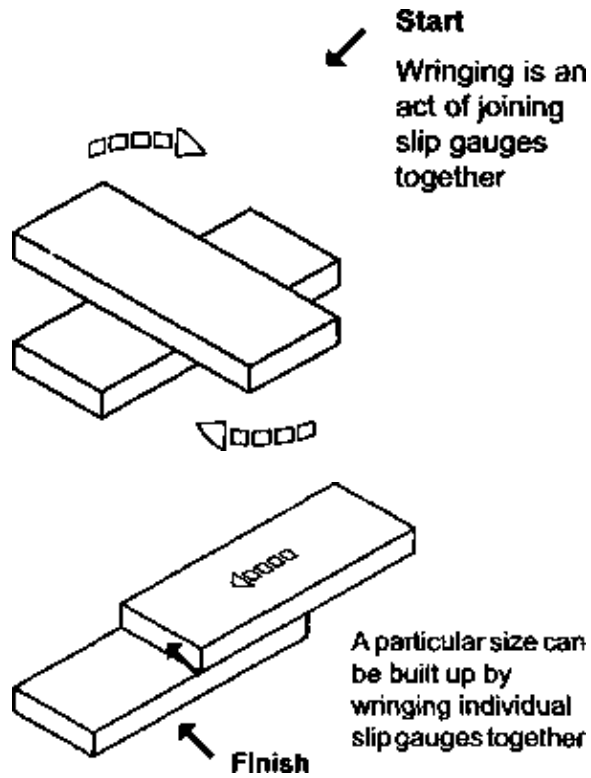

Protector slips of standard thicknesses from higher wear resistance steel or tungston carbide are available in some sets.

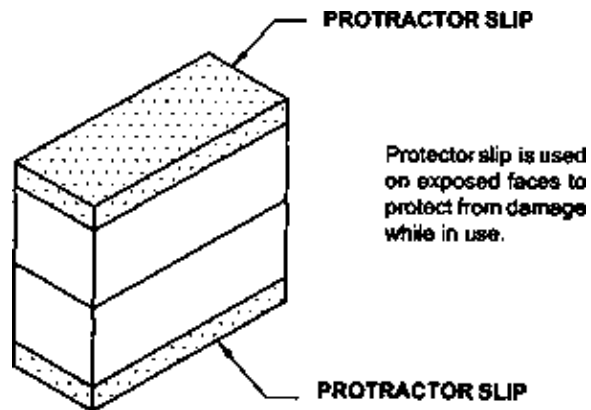

Determining slip gauge size

TR 01 01 01 02 02

PROCEDURE	SLIPS USED	CALCULATION
a) Write the required dimension		74.643
b) Select 1st series slip that has the same last digit	(Subtract 1.003)	<u>1.003</u>
		73.640
c) Select 2nd series slip – same last figure & the remainder must be either 0.0 or 0.5	(Subtract 1.140)	<u>1.140</u>
		72.500
d) Select a 3rd series slip – expected remainder must be a 4th series figure	(Subtract 22.500)	<u>22.500</u>

		50.000
e) Select the 4th series slip –remainder must be zero	(Subtract 50.000)	<u>50.000</u>
		0

Range (mm)	Steps (mm)	No. of pieces
Special pieces 1.0005		1
1st Series 1.001 to 1.009	0.001	9
2nd series 1.01 to 1.49	0.01	49
3rd series 0.5 to 24.5	0.5	49
4th series 25.0 to 100.0	25.0	4
Total pieces		112

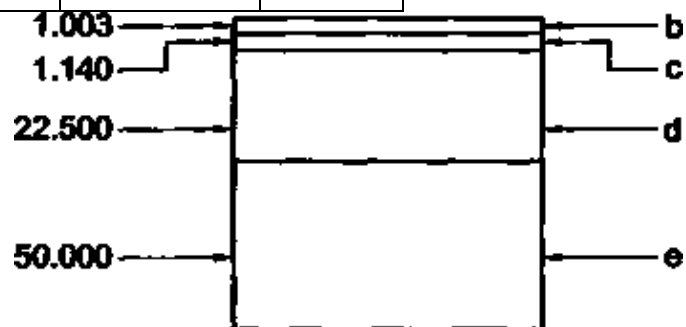

Special micrometers

TR 01 01 06 03 02

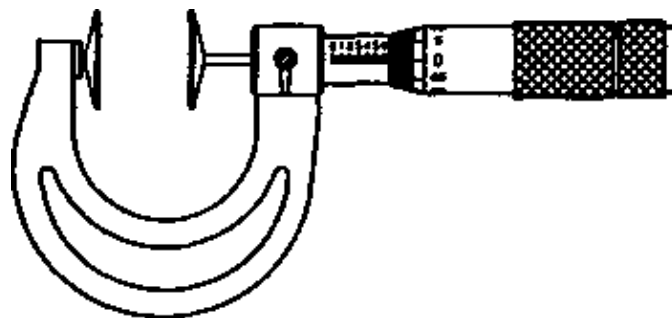

Flange micrometer

Flange micrometer is used to measure

- Chordal thickness of gear tooth
- thickness of engine fins
- collar of jobs etc.

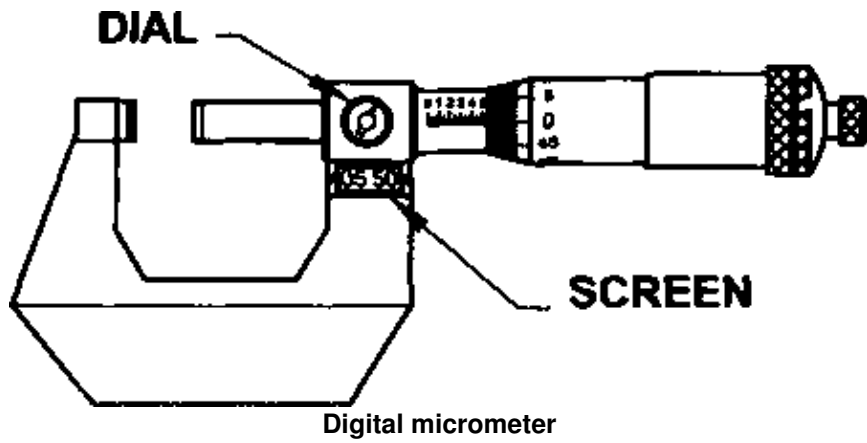

Digital micrometer is similar to outside micrometer. Measurements can also be read directly from the digital display.

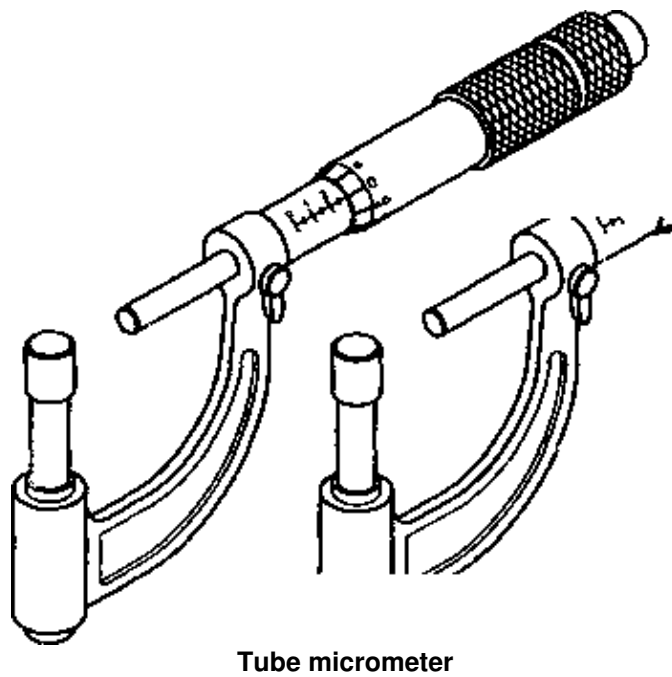

Tube micrometer is used to measure the wall thicknesses of Pipes tubes and other hollow parts.

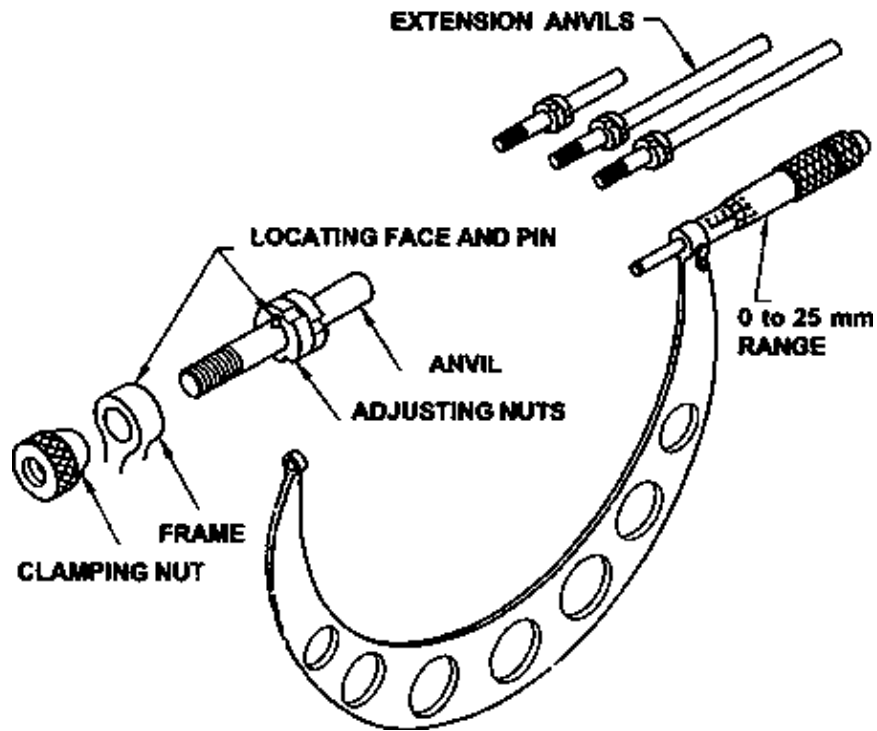

A Single External micrometer

A Single External micrometer with interchangeable anvils can replace many outside micrometers of different ranges.

A single micrometer can be used by merely changing different anvils.

Drill jig

TR 01 01 09 04 02

Jigs are used in mass production for drilling and allied operations.

Jig holds, supports and locates the component. Locates and guides the cutting tool.

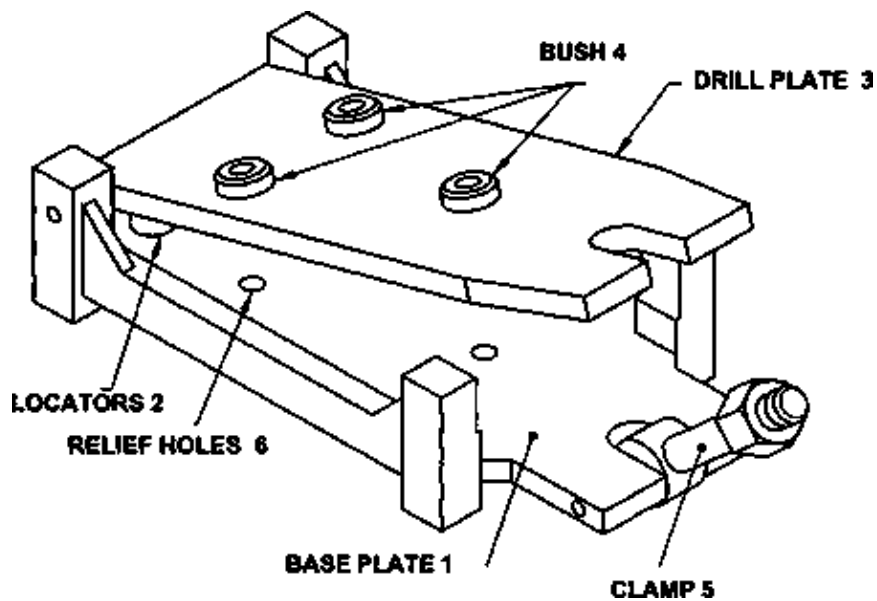

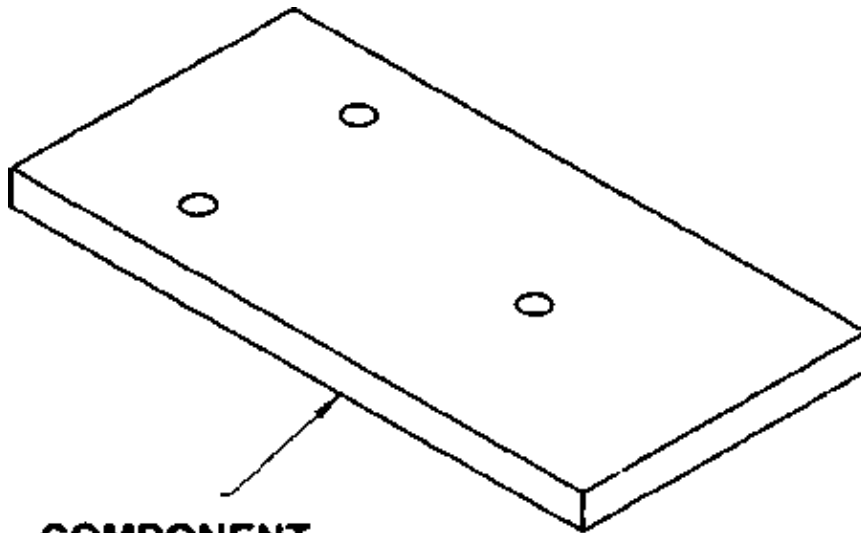

COMPONENT

Features and functions:

Base plate (1) is a solid support for mounting component. Locators (2) are positioned on this. These locators are used to position and restrains the movement of the component. Drill plate (3) holds bush/bushes (4) for cutting operation. Purpose of these bushes to locate and guide drill/reamer etc. clamp (5) is to be designed in such a way that loading and unloading of component must be easy and quick. Relief holes (6) are drilled on the base plate for clearing chips.

Fixtures

TR 01 01 09 05 02

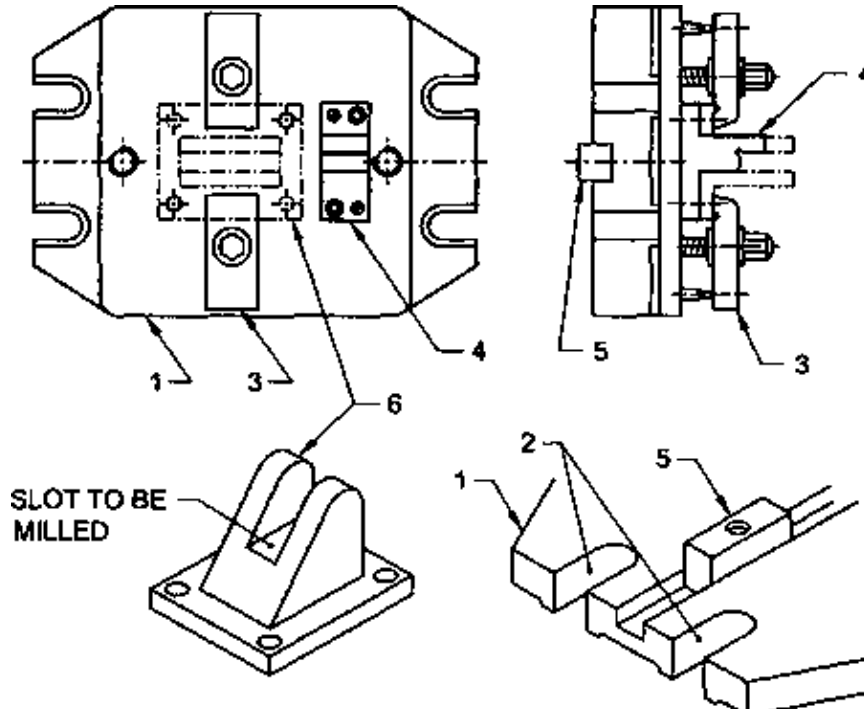

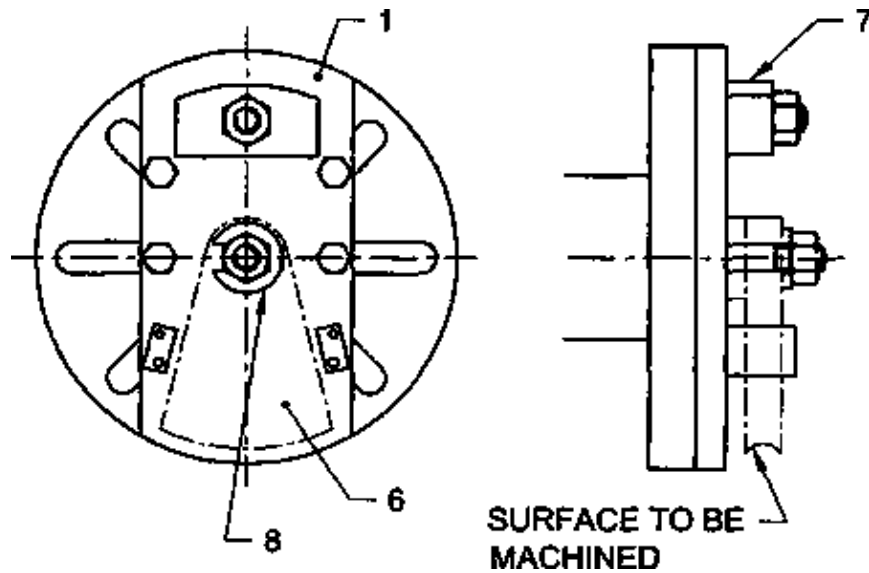

Fixtures are made and used for:

- Maching operations like milling, turning, grinding.
- Welding
- Bending
- Assembly, etc.

Base plate (1) of the milling fixture is provided with tenons (5) at its bottom for the correct location of the fixture with machine table through Tee Slots. Two or four holding down slots (2) meant for the rigid clamping of fixture base with the machine table. Setting block (4) is used to position fixture and work (6) relative to the milling cutter before machining.

Balancing weight (7) of turning/grinding fixture is used to balance the irregular work piece (6) 'C' washer (8) is helpful for easy loading and unloading of workpieces.

Limit plug gauges

TR 01 01 11 06 02

Limit plug gauges are used to check whether the hole portion of the component lie within the limits of size prescribed by the manufacturer.

Cylindrical limit plug gauges are used to check the inside diameter of a straight hole of the component.

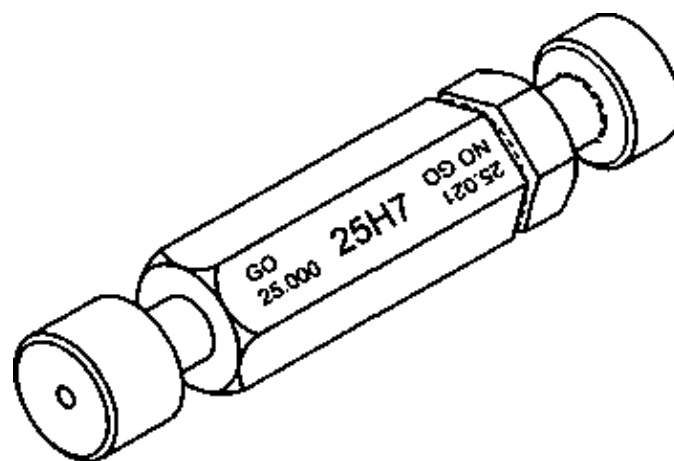

DOUBLE ENDED PLUG

GAUGE

For easy identification.

– Go end is made longer than the nogo end.

OR

– a groove is cut on the handle near the no go end.

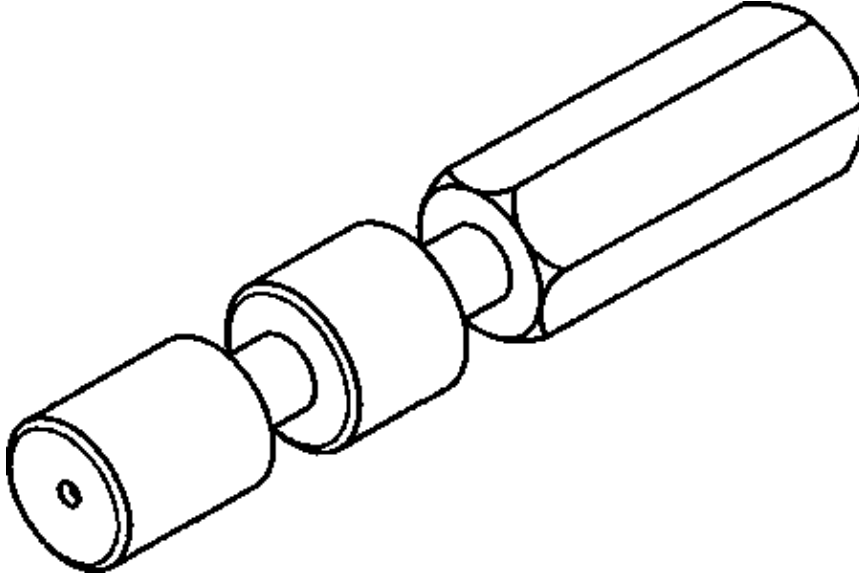

PROGRESSIVE PLUG GAUGE

PROGRESSIVE PLUG GAUGE

More convenient to use – How? In one action checking of go and no go limits possible

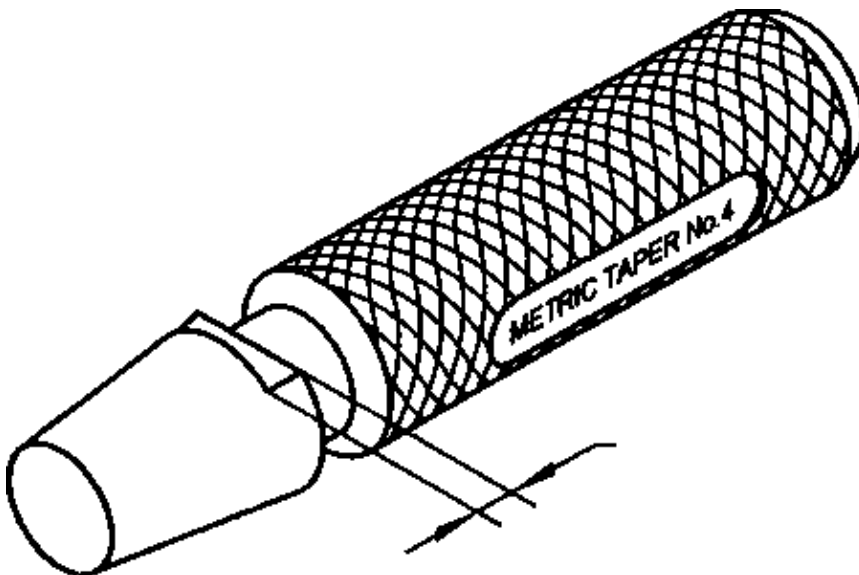

**END OF COMPONENTS MUST
LIE BETWEEN THESE STEPS**
TAPER PLUG GAUGE

TAPER PLUG GAUGE

Used to check standard taper jobs and also special taper jobs for specific use.

Check

- size of hole
- Accuracy of taper

The gauge is made to slide into the hole for a prescribed depth and at the same time fit properly.

Incorrect taper-gauge will wobble inside the hole.

Limit ring and snap gauges

TR 01 01 11 07 02

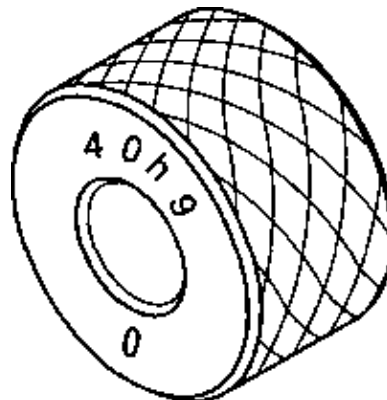

GO RING GAUGE

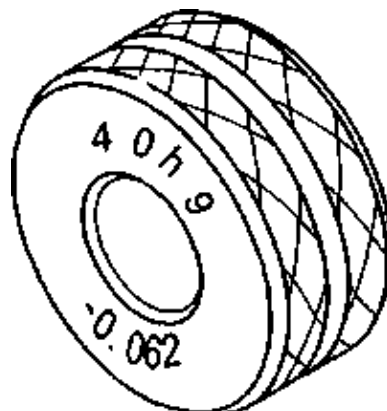

NO GO RING GAUGE

TAPER RING GAUGES are used to check both the accuracy of taper and the outside diameter of an external taper.

A step ground on the smaller end to indicate Go and nogo positions.

Accepted taper component's smaller end must lie within the step.

LIMIT RING GAUGES

are used for checking whether the circular shaft portion of a component lie within the limits of size or not.

No go gauge is identified by an annular groove cut on the knurled surface.

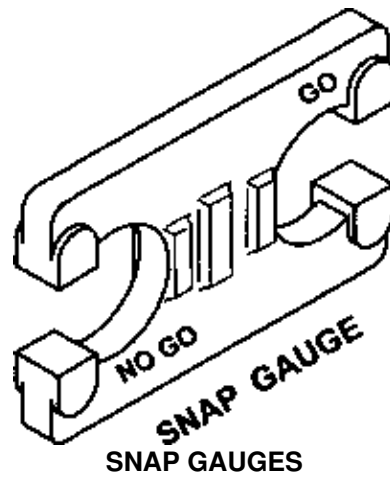
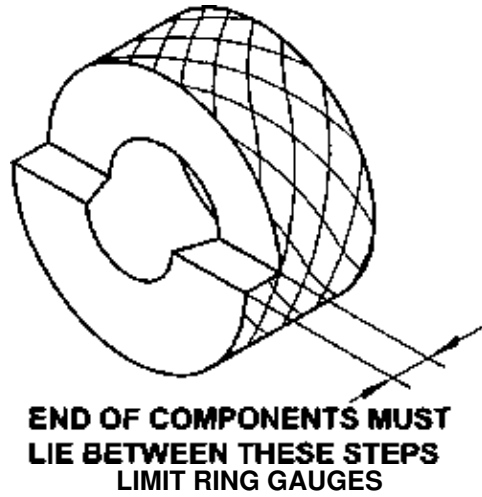

SNAP GAUGES are used to check external dimensions of jobs other than cylindrical ones also.

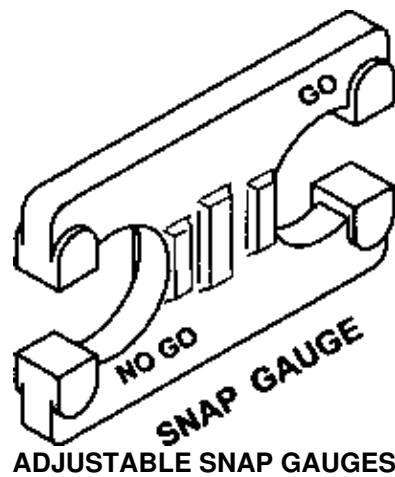

ADJUSTABLE SNAP GAUGES possible to set and check different go and nogo deviations of the component.

Checking can be done after setting and locking adjustable anvils to the required maximum and minimum limits of size using slip gauges.

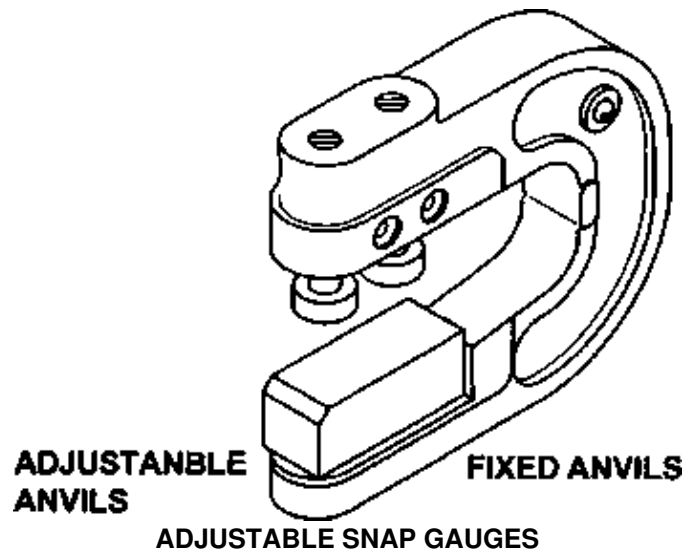

Shaper stroke length & cutting speed

TR 01 01 11 08 02

Conversion of rotary motion of bull gear into the linear motion of shaper is a simple harmonic motion.

Speed characteristic of simple harmonic motion is that the

- zero speed at the starting of the stroke.
- Maximum speed at the middle of the stroke.
- Again zero speed at the end of the stroke.

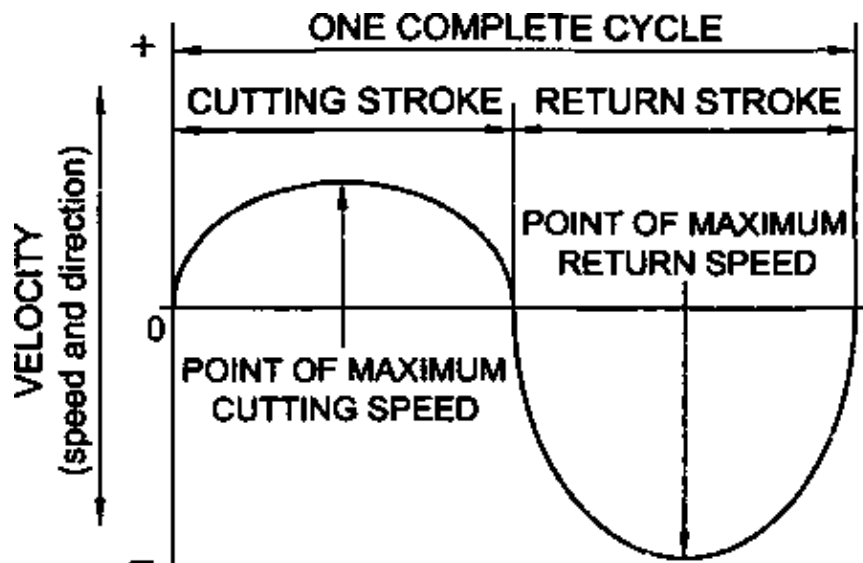

3 or 5 speed ranges are available for setting the rpm of the bull gear of shaper. Even the bull gear is set to a particular rpm stroke length can be changed by changing the radial distance (R/r)

This change of length (L/l) of ram causes a change in cutting speed of ram.

Longer the length of stroke of ram greater the cutting speed of ram.

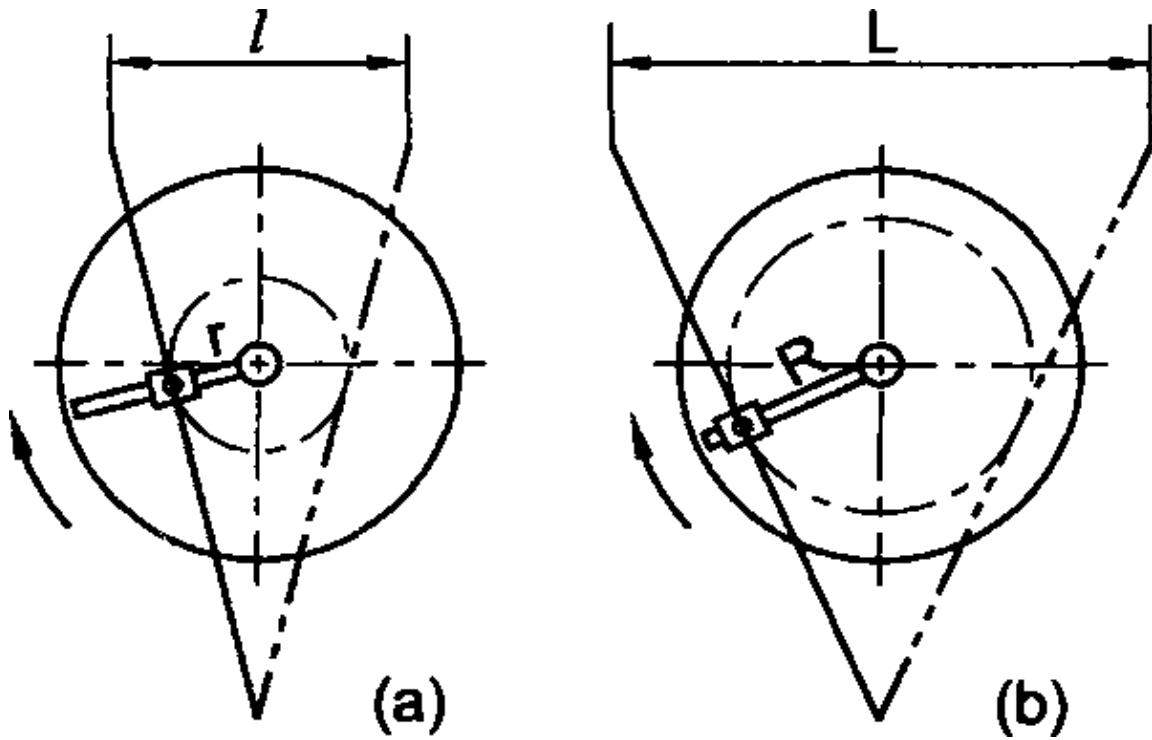

If the stroke length is very much longer than length of the job, tool velocity will be very much high when the tool strikes the job.

Due to the high velocity

- Cutting edge of tool may chip.
- Work may be dislodged
- excessive machine wear.

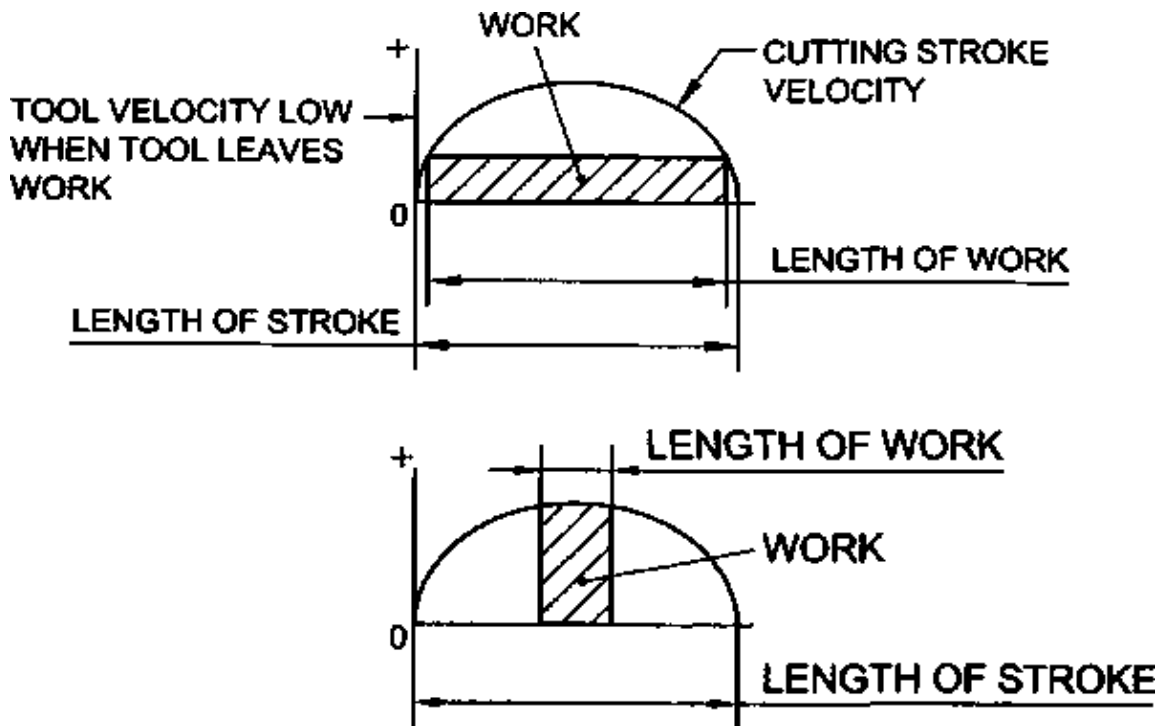

Hardness testing – Brinell

TR 01 02 13 09 02

Suitable for testing hardness of soft materials like
Cast iron, Lead, Copper alloys, Aluminium etc.

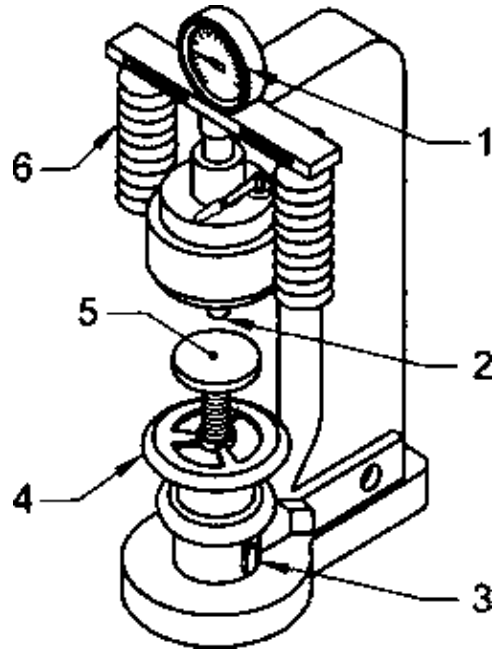

Applying load – 100, 250, 500, 1000, 1500, 2000, 2500 or 3000 kgf

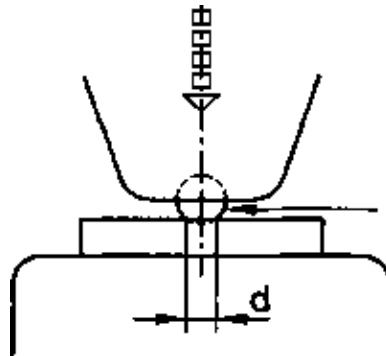

1. Apply load



Circular impression is made by the indenter

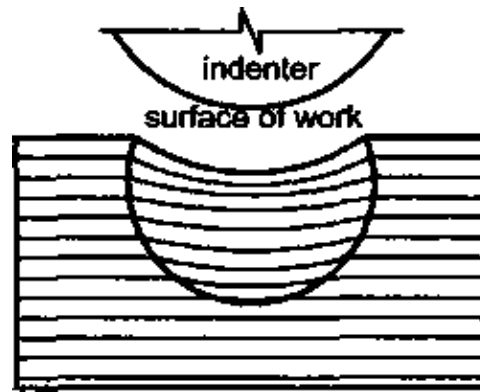

2. Create impression on job

3. Measure mean diameter of impression

Impression made is measured by using a microscope and a scale

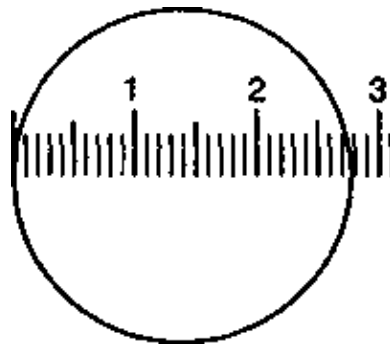

Formula for finding hardness where $(HB) = ?$

where

P = Applied Load (kgf)

D = Diameter of ball

d = Mean diameter of impression

4. Apply formula and get hardness value (HB)

Hardness testing – Vicker

TR 01 02 13 10 02

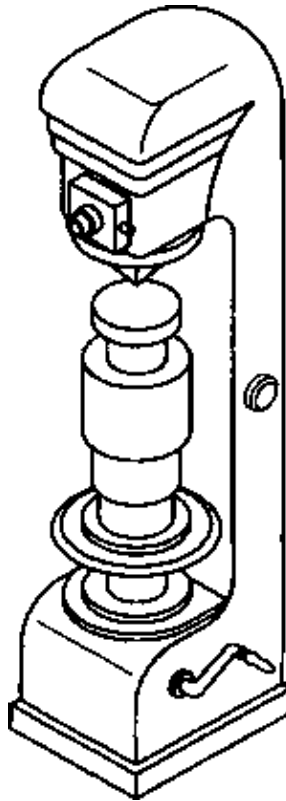

VICKER'S HARDNESS TESTER

This method of testing is done using Vicker hardness tester

The load used is from 5 to 120 kgf. (5, 10, 20, 30, 50, 100 or 120 kgf)

This test is used for testing hard specimens like: Cutting tools and heat treated components

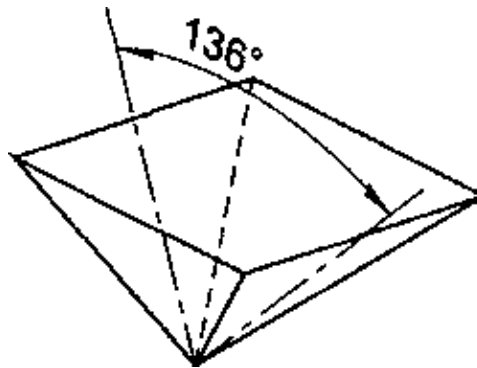

Indenting tool used is the highly polished diamond pyramid.

Indenting tool will make diamond shaped impression on the job due to the application of the load.

Mean diagonal of the impression can be measured using a microscope and scale.

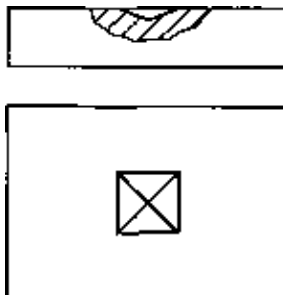

Formula for finding Hardness Vicker (HV) =

where

P is the load in kgf and

d is the mean diagonal of the impression in mm.

Hardness testing – Rockwell

TR 01 02 13 11 02

Many scales are available in this Rockwell hardness testing method (P) Standard scales are:

Hardness Rockwell B–scale (HRB) for Copper, Aluminium alloy, Mild Steel.

Hardness Rockwell C–scale (HRC) for Steel, Hardened steel.

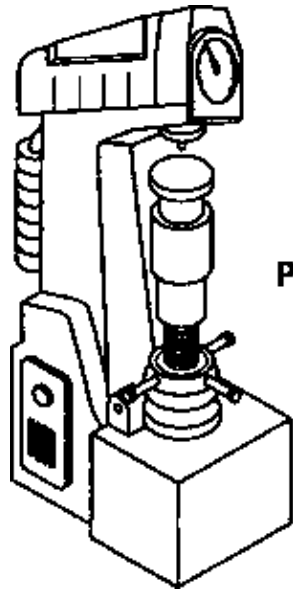

Indenting tool

A steel ball (Q) for B–Scale (HRB 0 to 130)

A diameond cone (R)for C– Scale (HRC 0 to 100)

First a minor load of 10 kgf (98.1 N) is applied on the job to avoid getting wrong reading due to the hardness of the top layer of job and also due to the backlash of machine.

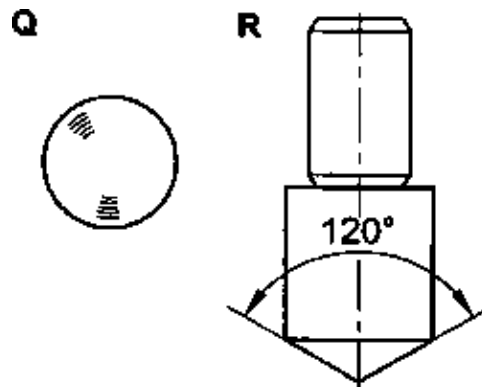

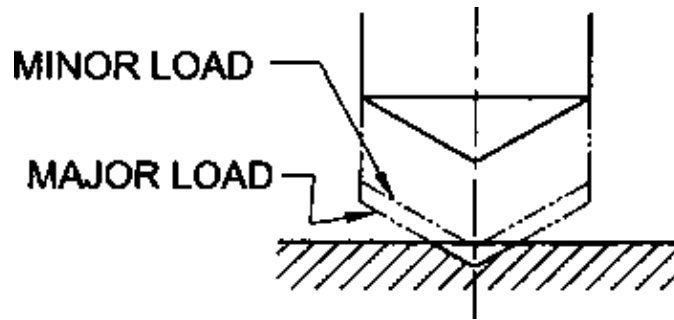

Then a major load of

- 100 kgf (981 N) is applied B-Scale.
- 150 kgf (1471 N) is applied C-Scale.

Due to the major load application a further deep impression is formed on the job.

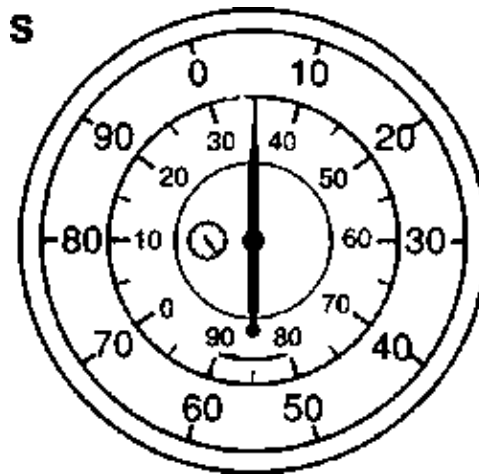

The difference in depth of penetration is directly read from the dial (S) of the machine.

Refer table and convert the difference of depth of penetration to the hardness value of the respective scale.

Tool Maker's Button

TR 01 03 09 12 02

Tool Maker's button is used to produce bored holes to a high degree of positional accuracy with reference to both axis

Tool Maker's button is a hardened and ground steel cylinder of 8, 10 or 12 mm available in set of 3 or 4 cylinders.

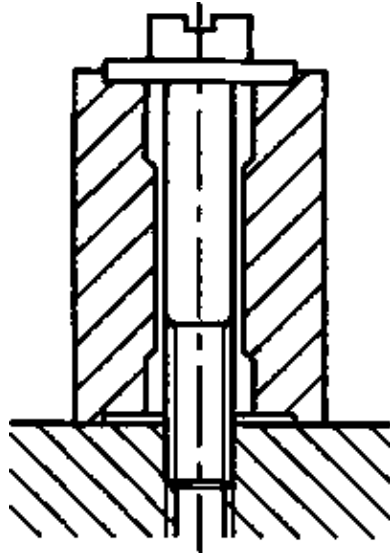

Step 1. Mark the position of hole from the reference edges.

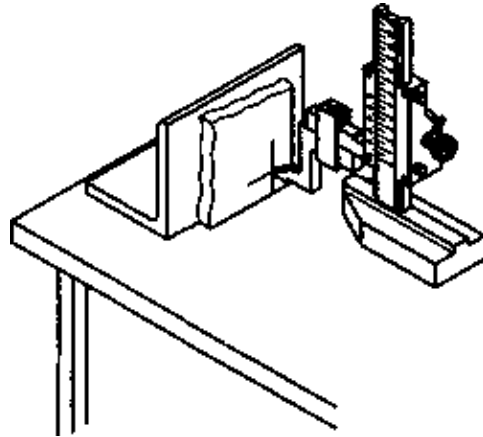
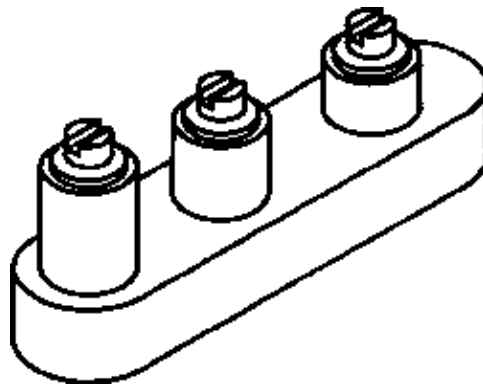

Step 2. Drill a hole for tapping BA thread in the position marked. Tap BA thread for fixing ?10 tool maker's button.

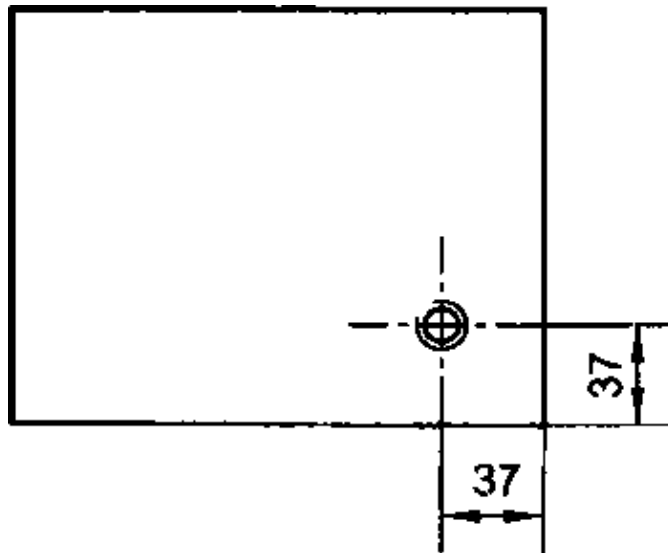

Step 3. Set the button in position using slip gauges.

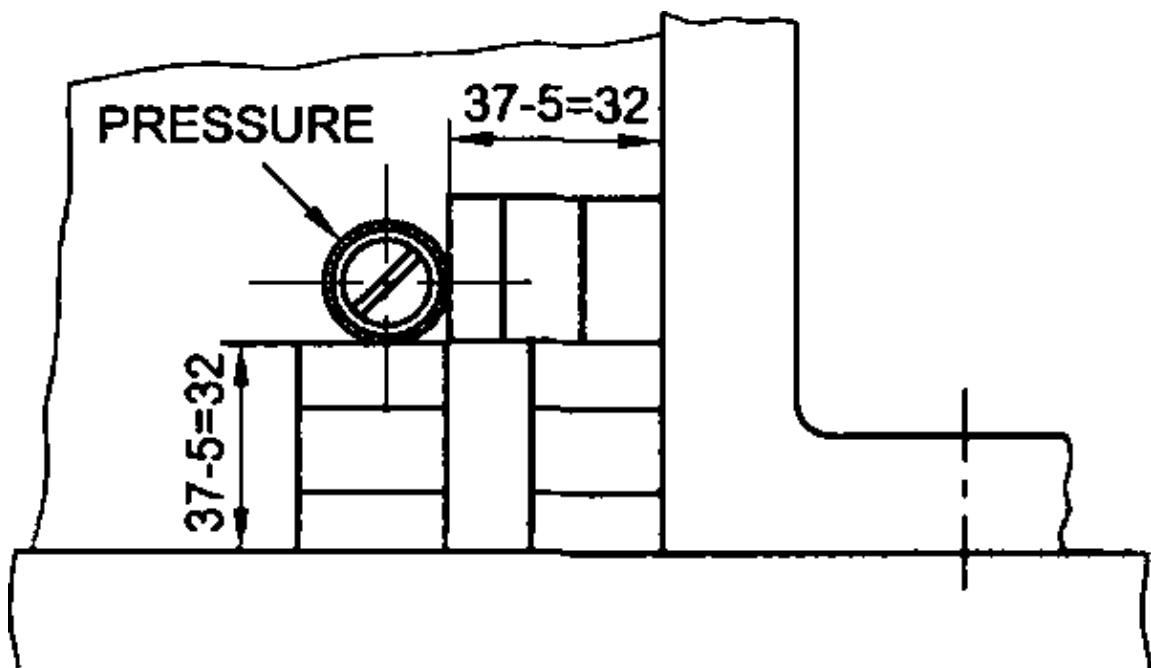

Step 4. After fixing the button, set and align the job.

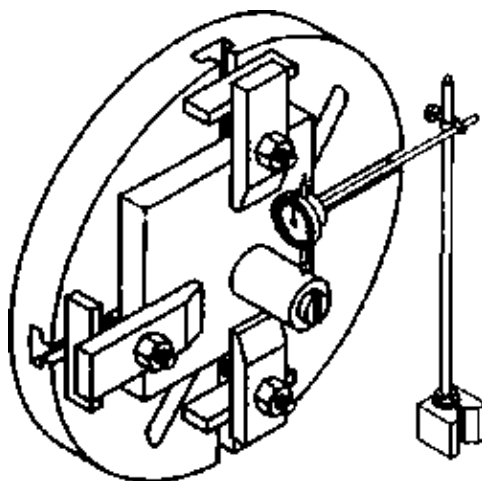

Step 5. Remove button, drill and bore the hole.

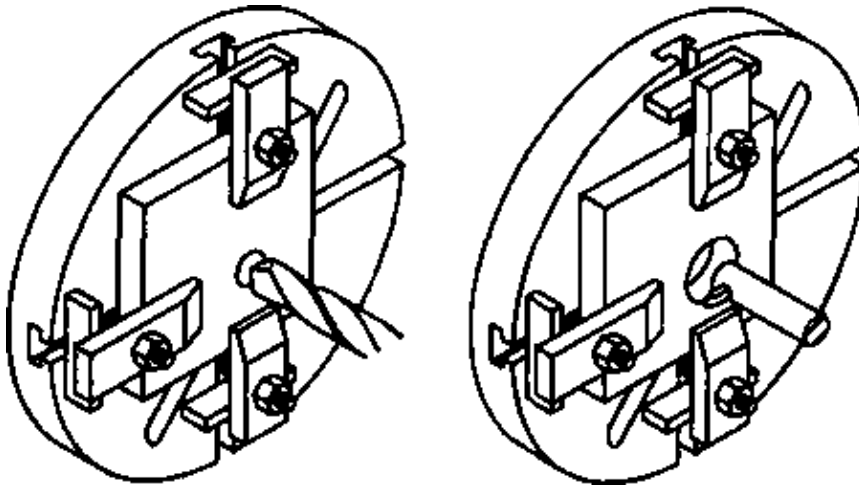

Measurement of screw thread elements – I

TR 01 03 23 13 02

ELEMENTS FOR MEASUREMENT

Following elements of a Vee thread is required to be checked according to the requirement.

- Major diameter
- Minor diameter
- Pitch
- Effective diameter
- Profile Angle
- Form of Crest and root

For checking the elements different instrument/method can be used.

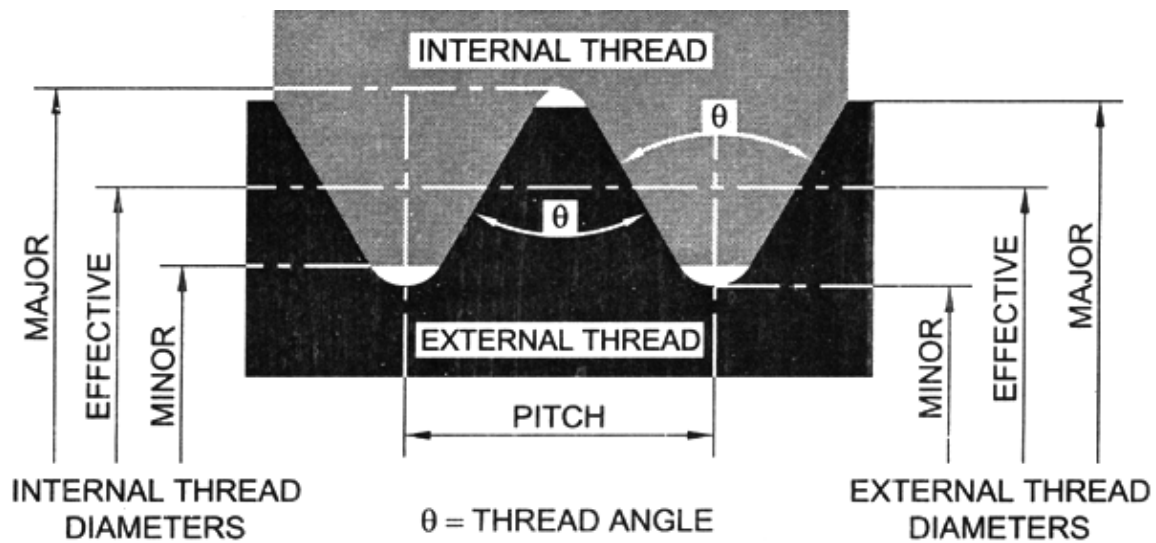

SCREW PITCH GAUGE is used to check pitch of the screw threads (both external and internal)

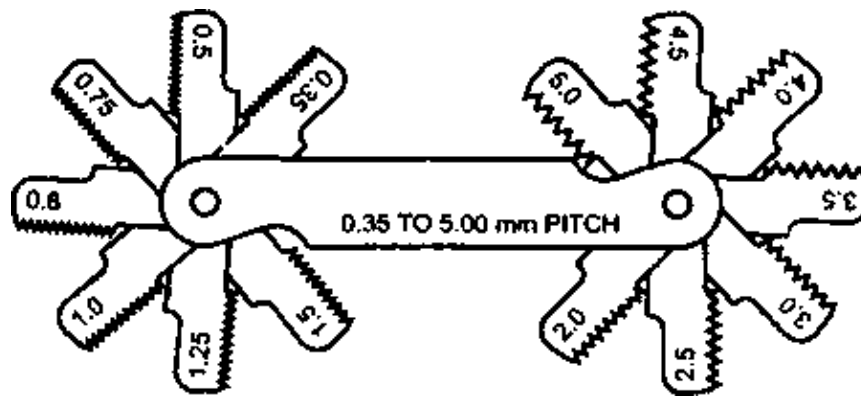

SCREW PITCH GAUGE

SCREW THREAD CALIPER GAUGE is used to check pitch of the screw threads (both external and internal)

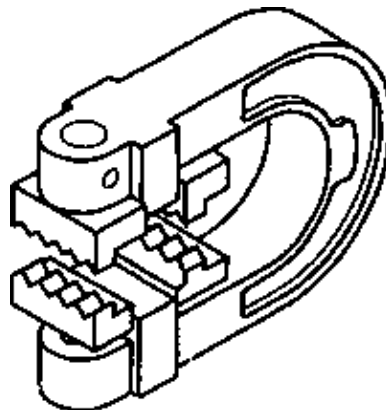

SCREW THREAD CALIPER GAUGE

SCREW THREAD PLUG GAUGE is used to check all the main elements of internal Vee threads within limits

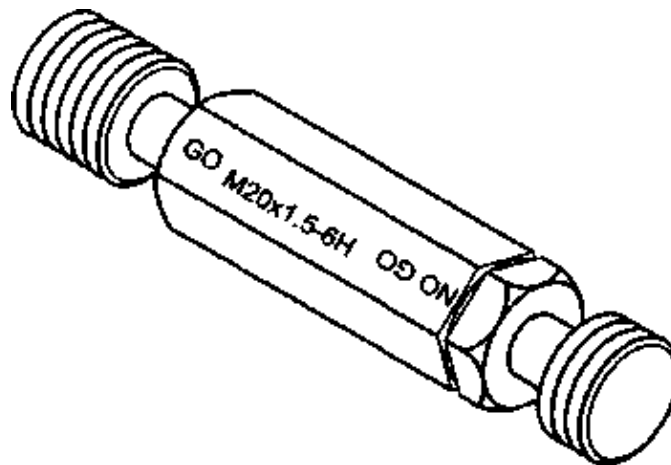

SCREW THREAD PLUG GAUGE

SCREW THREAD RING GAUGE is used to check all the main elements of external Vee threads within limits.

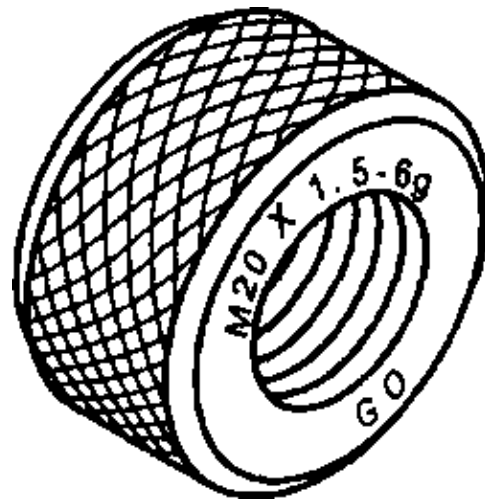

SCREW THREAD RING GAUGE

Measurement of screw thread elements – II

TR 01 03 24 14 02

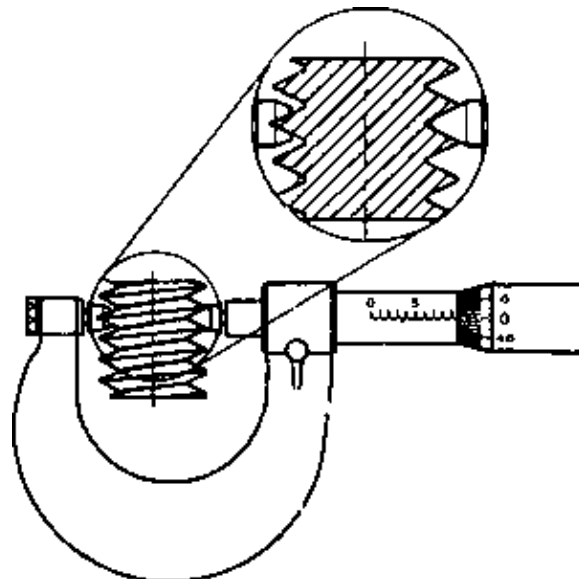

SCREW THREAD MICROMETER

SCREW THREAD MICROMETER is used to measure the effective diameter of the thread.

Anvils of the micrometer are replaceable, according to the profile and pitch of different systems of Vee thread, they are changed and used.

THREE WIRE METHOD is used for measuring the effective diameter of the screw threads.

Three wires suitable for thread pitch are placed between the threads.

Diameter M_1 can be measured using outside micrometer. Using the values of M_1 diameter of the wire and thread angle, effective diameter can be calculated precisely.

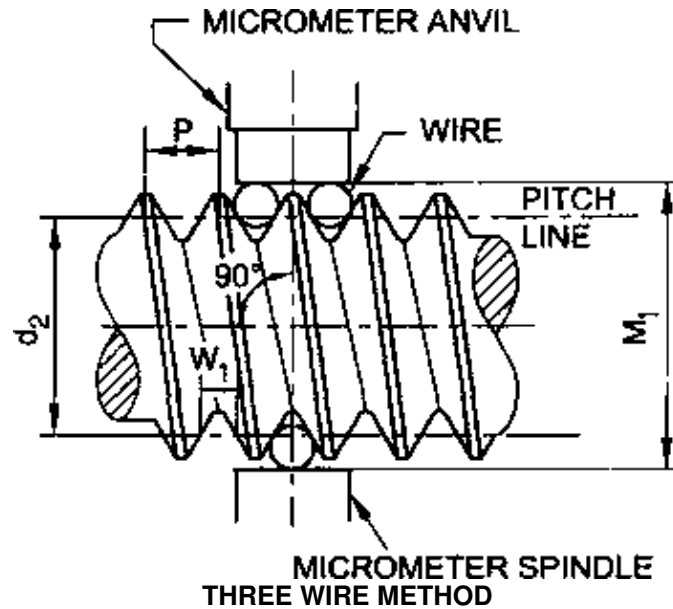

VERNIER CALIPER is used to measure the root diameter of both external and internal threads.

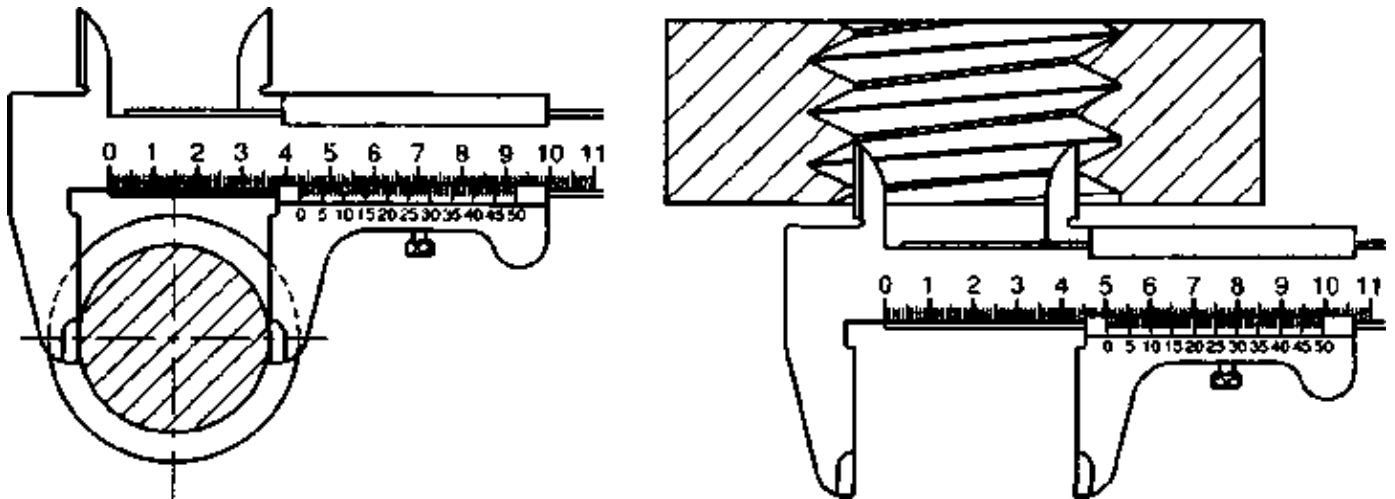

VERNIER CALIPER

OUTSIDE MICROMETER AND A VEE PRISM can be used to measure the minor diameter threads.

First measure the outside diameter of the thread using outside micrometer or vernier caliper. Then measure and get value over prism.

Outside diameter – (Measurement over prism – height of prism) = 1 depth

Outside diameter – 2 depth = root/core diameter.

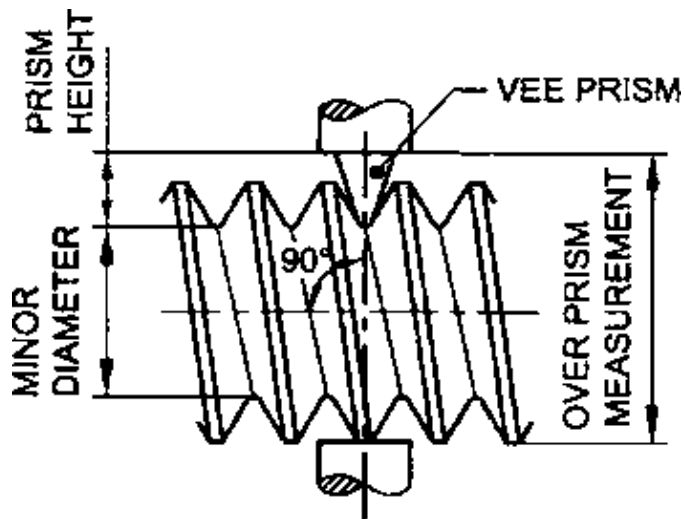

OUTSIDE MICROMETER AND A VEE PRISM

SPECIAL MICROMETER with the anvils as shown can be used to get the root diameter directly.

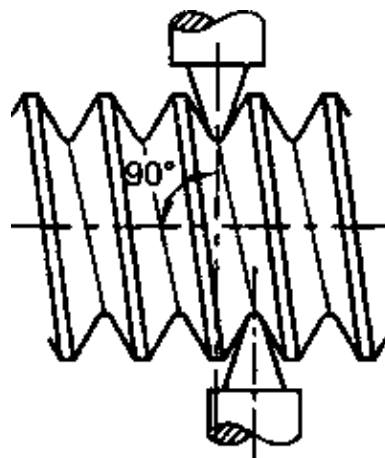

SPECIAL MICROMETER

Types of screw thread

TR 01 03 25 15 02

SQUARE THREAD flanks are perpendicular to the axis of the thread. Crest and root are bevelled to 45°. Depth of the nut is longer than the bolt. These threads are used for transmitting motion or power. Eg. Screw Jack, Vice Spindle, Cross slide and Compound slide screws.

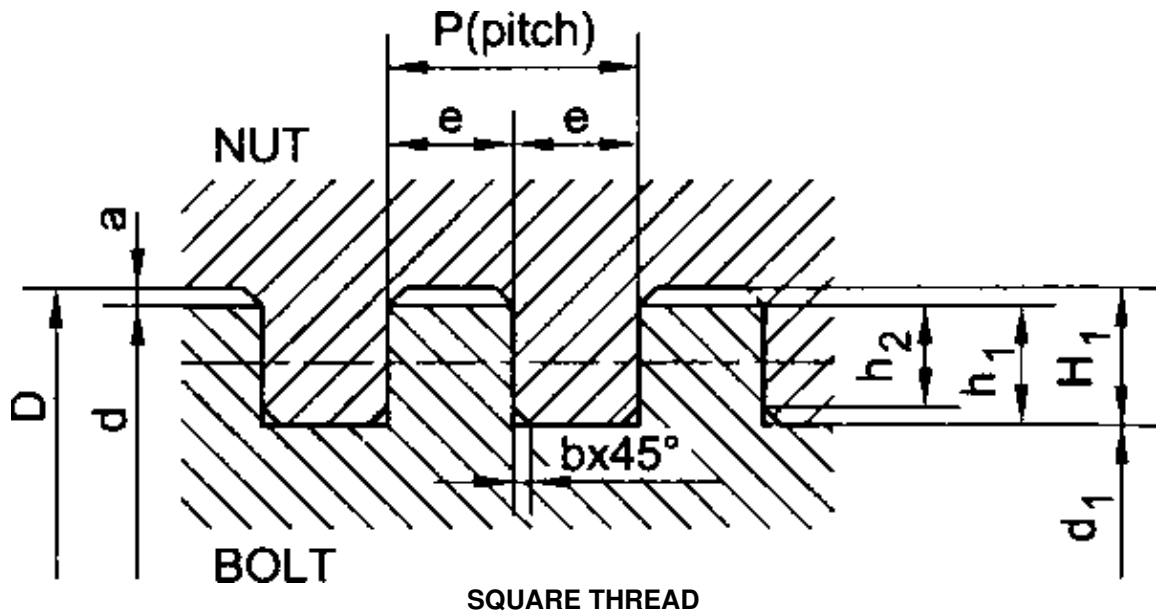

BRITISH ACME THREAD is used in the lead screw of lathe.

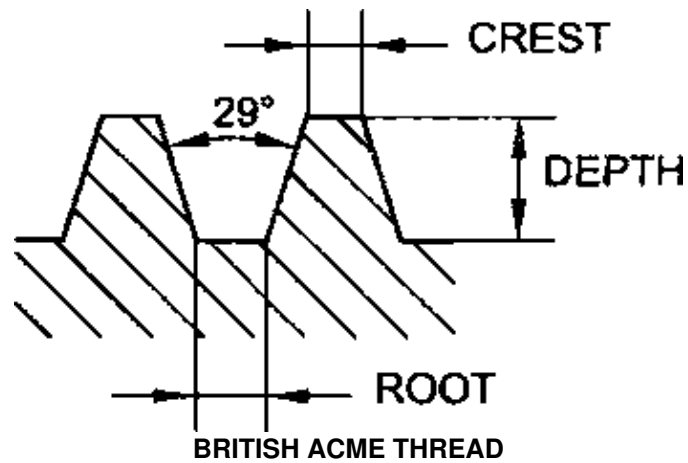

WORM THREAD is cut on the worm shaft which engages with worm wheel. The worm wheel and worm shaft are used in places where motion is to be transmitted between shafts at right angle.

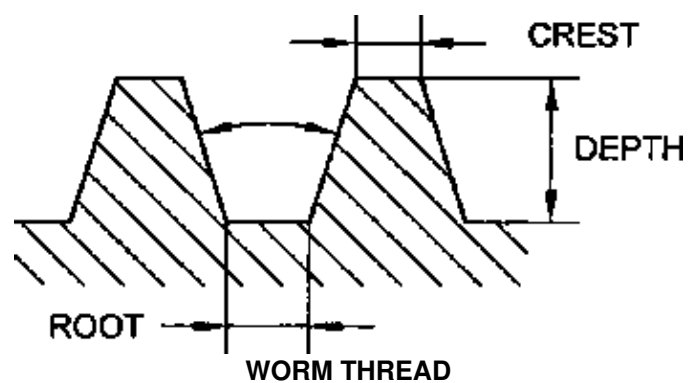

BUTRESS THREAD: These threads are used on parts where force acts at one flank of the thread during transmission.

Eg. Carpentry Vice, Ratchet etc.

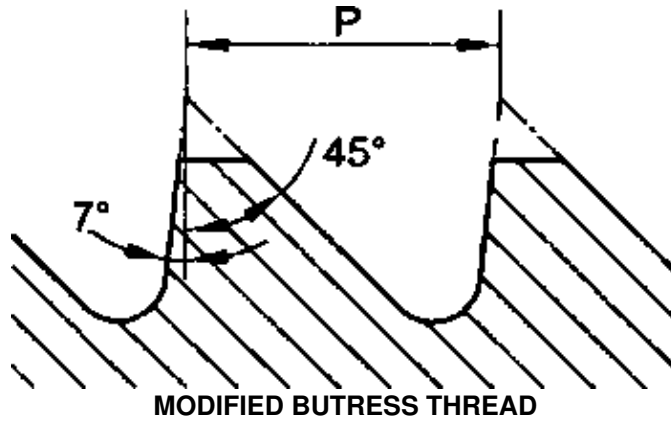
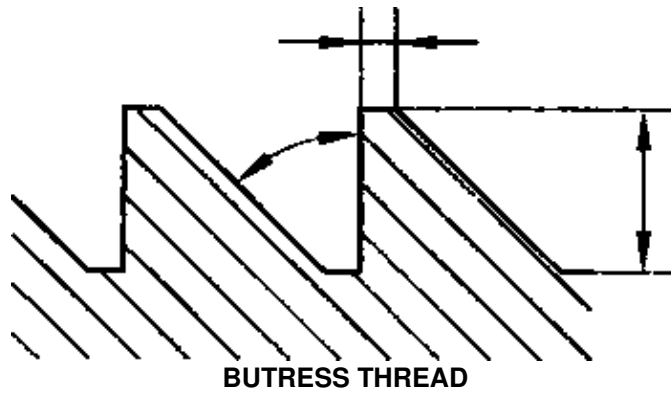

METRIC ACME THREAD: Similar to british acme, but angle of the thread is 30°.

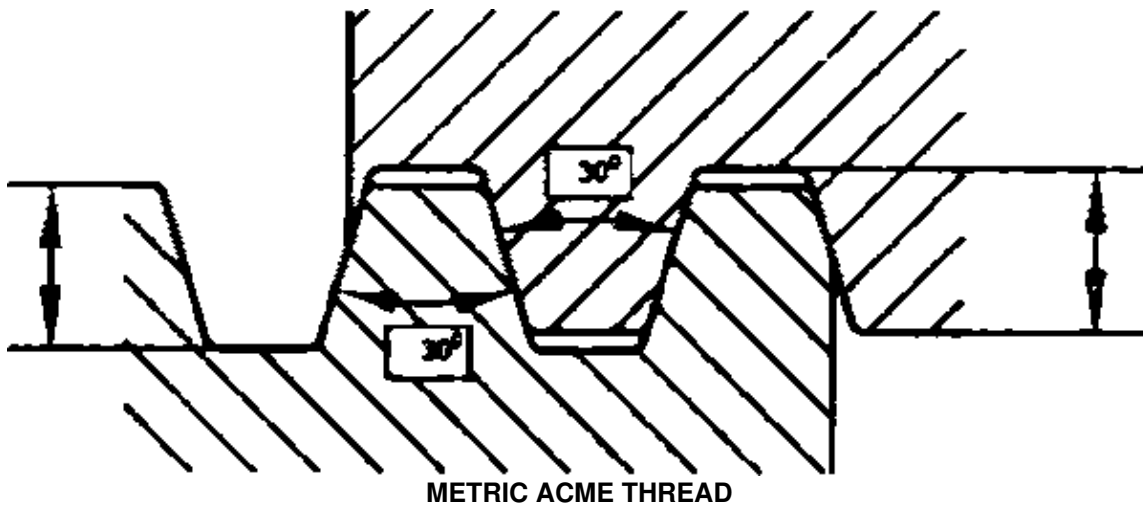

KNUCLE THREAD: These threads are used in railway carriage couplings etc.

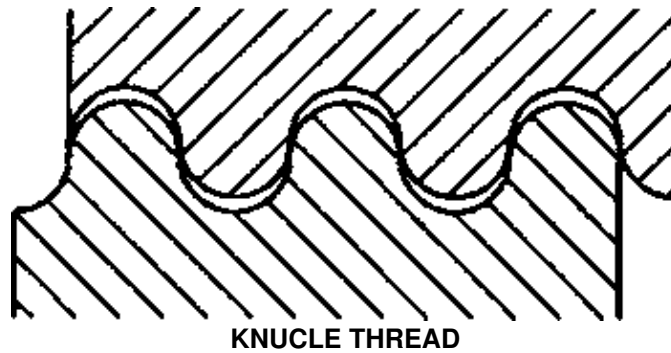

Movements & restraints of work – I

TR 01 03 38 16 02

There are twelve possible movements for any object.

- Front & Back (7 & 10)– Clockwise and Anticlockwise (4 & 1) 4 movements
- Right & Left (11 & 8) – Clockwise and Anticlockwise (2 & 5) 4 movements
- Up & Down (9 & 12) – Clockwise and Anticlockwise (6 & 3) 4 movements

According to the requirement, particular movement/movements can be arrested using clamps, pins, etc.

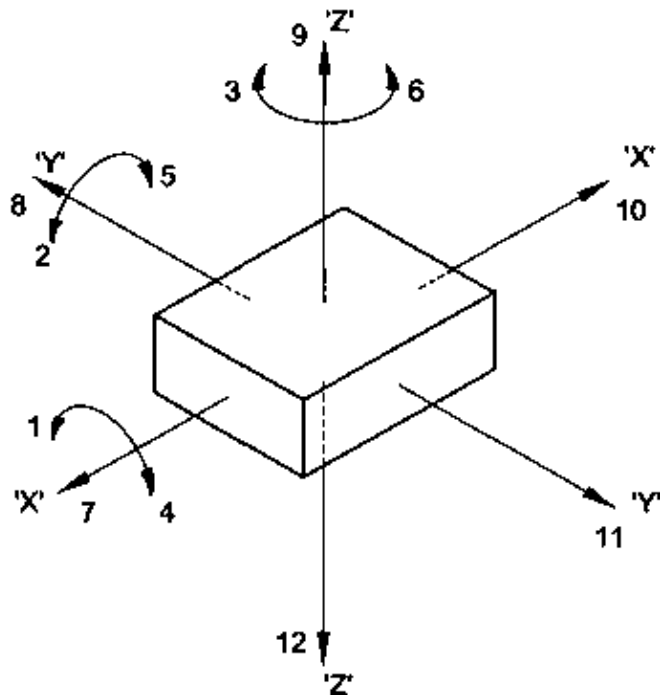

By placing a job on a base five movements of the job are arrested. They are 2, 5, 1, 4 and 12.

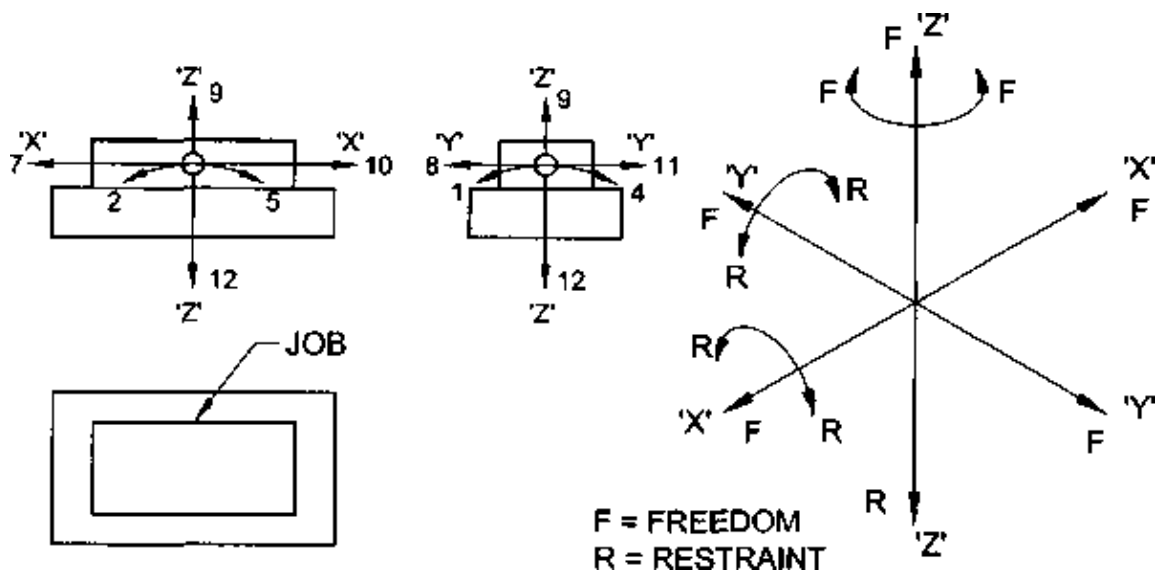

Movements & restraints of work – II

TR 01 03 38 17 02

Job is placed on a base with three pegs are supporting the job in two positions. Number of movements restricted in nine directions.

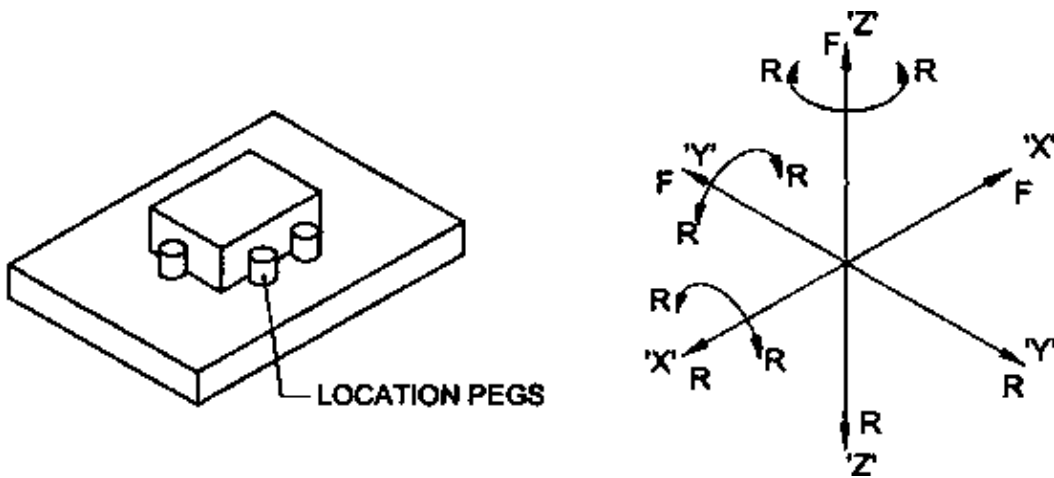

F = Freedom
R = Restraint

MACHINE VICE – Number of movements restricted (a) are nine

Freedom (F) – one direction; Cutting force is against the fixed jaw – A positive restraint to resist the cutting force. Friction resistance (b) – two directions.

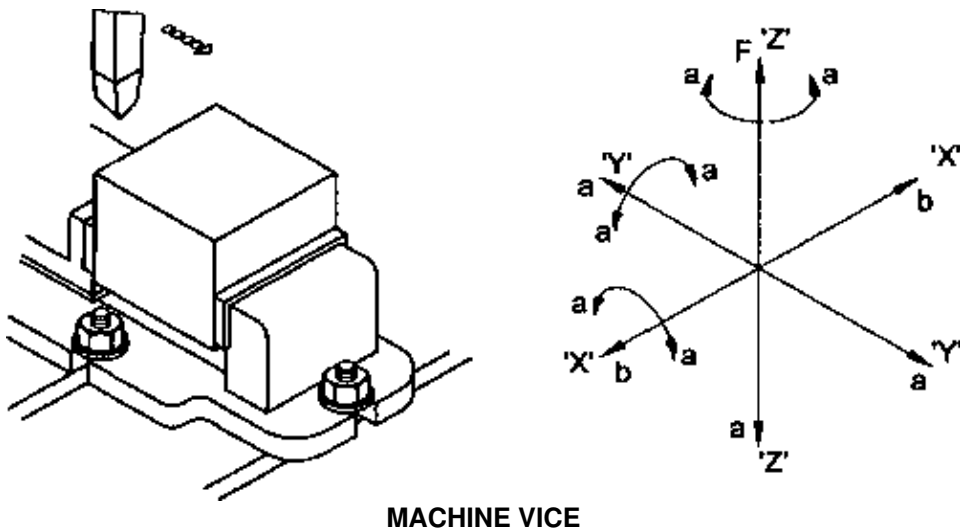

a = Positive restraint
b = Frictional restraint

FOUR JAW CHUCK – Movement of the job is restricted in eight directions fully. 'FR' is the frictional resistance between the job and the jaws of the chuck, both sliding and rotating about its axis during turning and facing etc. in four directions.

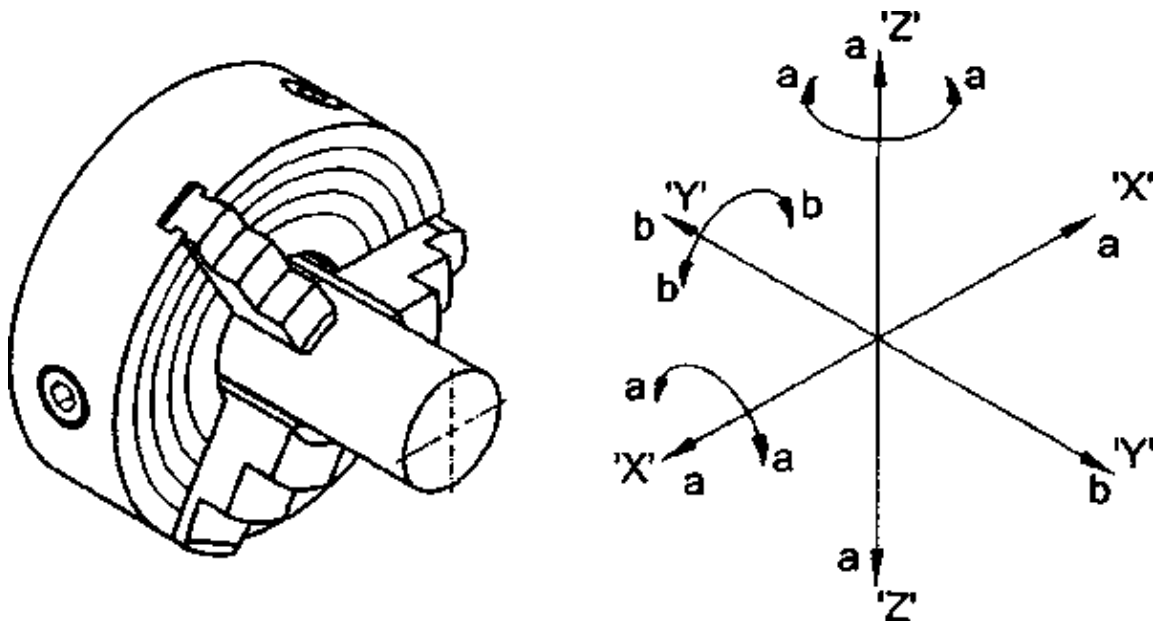

FOUR JAW CHUCK

Methods of applying lubricant

TR 01 04 03 18 02

For efficient lubrications of machine tools, following methods are employed for applying lubricants.

- Gravity feed method;
- Force feed method;
- Splash method;

GRAVITY FEED METHOD

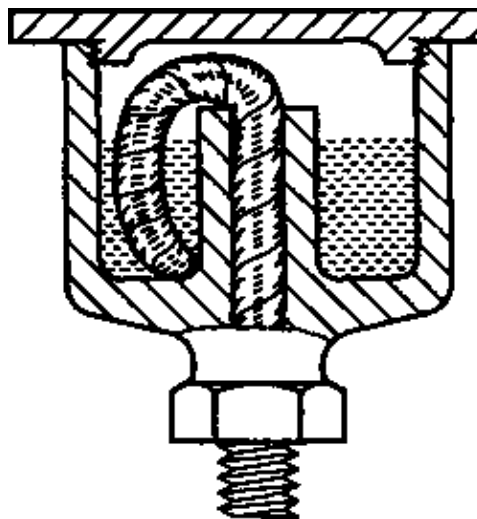

WICK FEED LUBRICATOR

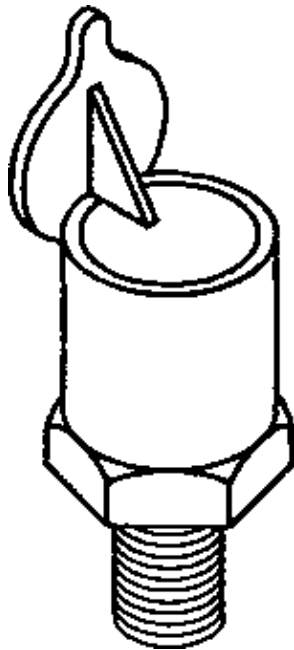

OIL CUP

FORCE FEED METHOD

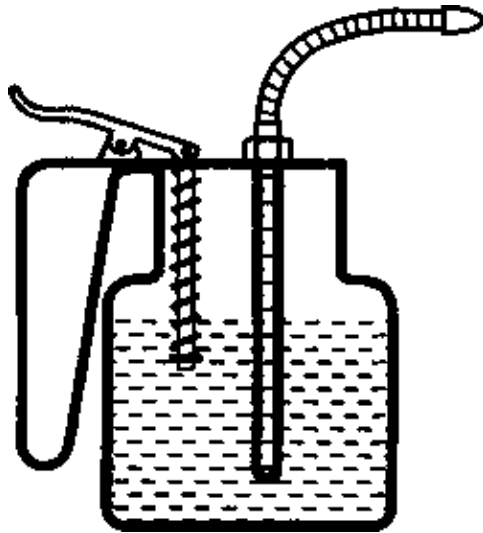

OIL CAN

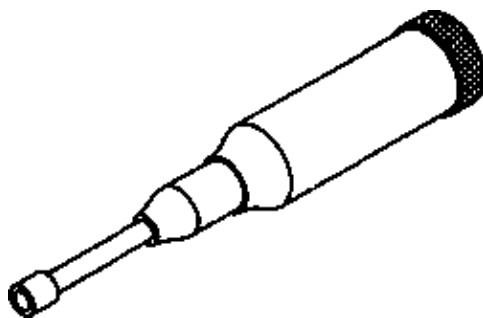

GREASE GUN

SPLASH METHOD

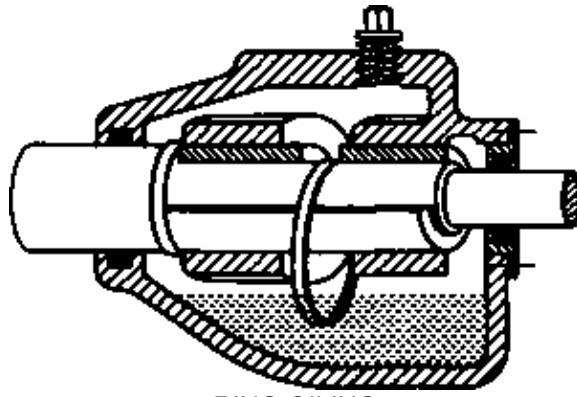

RING OILING

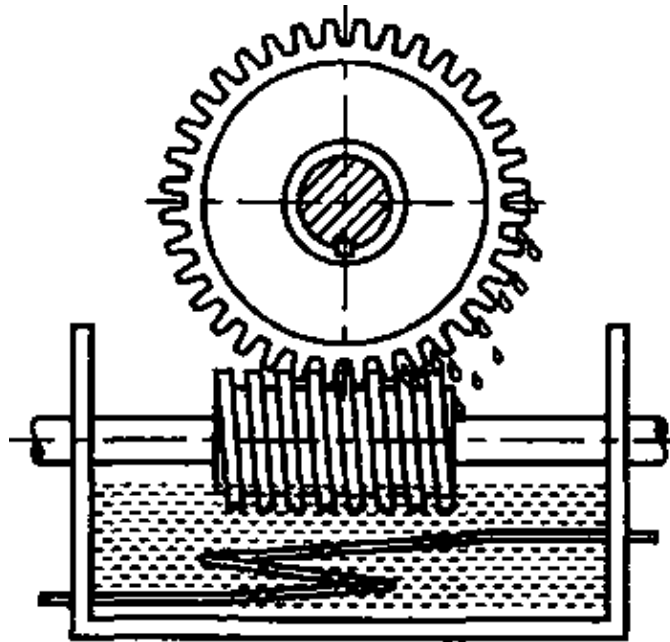

WORM - GEAR BATH OILER

Vertical milling machine

TR 01 05 01 19 02

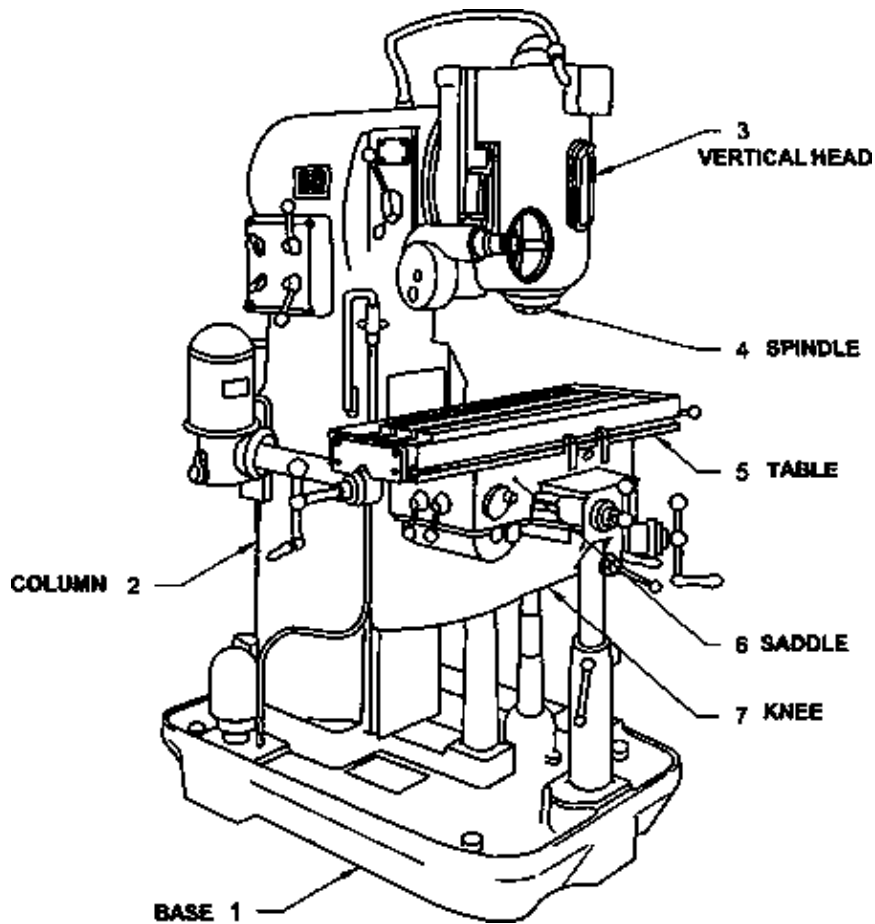

Construction and function of Parts (1) (2) (5) (6) (7) are similar to horizontal milling machine. The Vertical head (3) is connected to column (2). The vertical head can swivel in both clockwise and anticlockwise upto 45°. The spindle (4) is fixed to the vertical head (3) and can move up and down. Face milling and end milling operations can be performed using face mills and end mills. Angular milling can also be performed by swivelling the vertical head.

Differential indexing – I

TR 01 05 12 20 02

Divisions which cannot be obtained by simple indexing can be done using differential indexing. Eg., 51,57, 59, 127, etc.

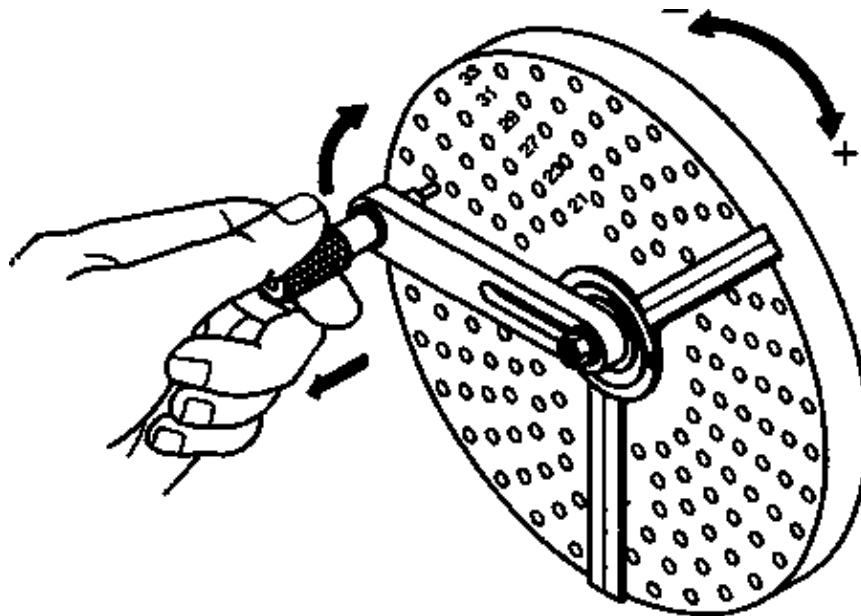

Differential indexing means the difference of two combined movements of both index crank and index plate.

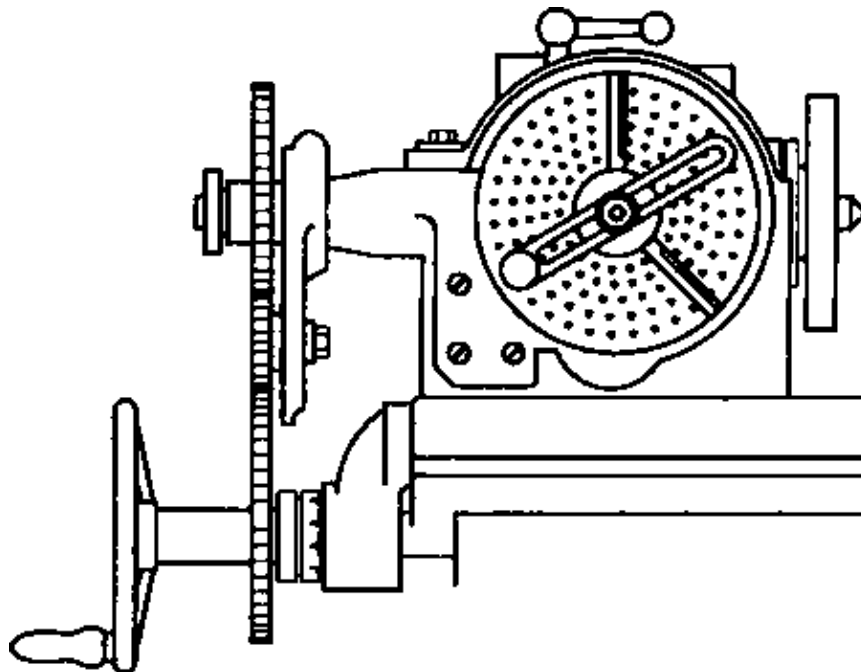

To achieve the combined motion, connect the extended spindle and the auxiliary worm shaft with gear train.

According to the required number of division (N) and the assumed number of Division (A), index plate is set to move in the same or in the opposite to the direction of crank depending on the number of idler gears used and the design of the indexing head.

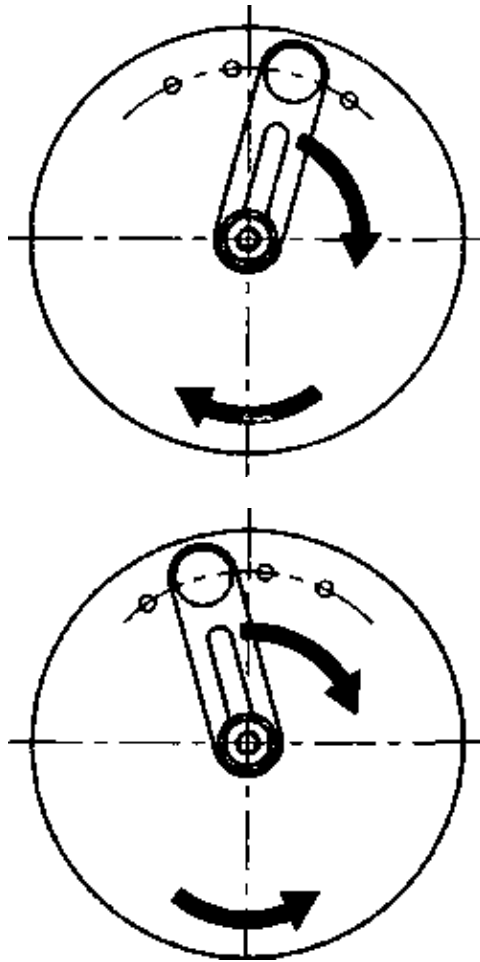

Differential indexing – II

TR 01 05 13 21 02

REQUIRED NUMBER OF DIVISION (N) TO BE INDEXED IS 57.

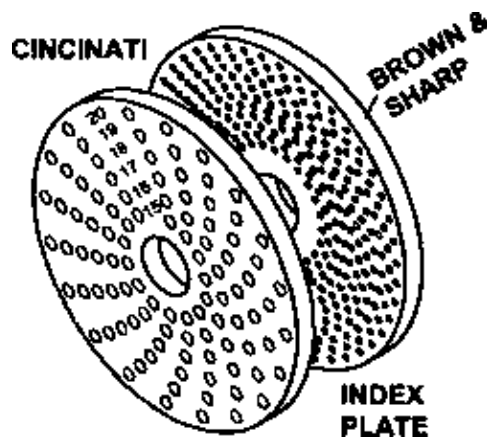

<p>* Select assumed number of division (A) (within $\pm 10\%$ of required number. • Assumed number must be suitable for simple indexing</p>	<p>* Select any suitable number ($\pm 10\%$) considering the available index plates.</p>
<p>Numbers selected are go)</p>	

	(55)	(60)
	Selected assumed number (A) is 55 (less than 57)	Selected assumed number (A) is 60 (more than 57)
* Select index plate and spacing using simple indexing • Simple indexing = * Select driver and driven gears	plate No. 2 of Brown & Sharp 33 hole circle – 24 spacing	Plate no. 2 of Brown & Sharp. 27 hole circle – 18 spaces 33 hole circle – 22 spaces
Gear ratio =		
* Direction of index plate rotation with respect to the rotation of index crank.	A (55) is less than N(57)–Gear ratio (-). In this case, index plate is to turn against the rotation of the index crank.	A (60) is more than N (57) –Gear ratio (+). In this case, index plate is to turn in the same direction of rotation of index. crank.
Index plate rotation (same/Opposite) is regulated by employing/engaging idler gears. One/two – according to the design of index head.		

Prior to indexing disengage the back stop pin to permit the rotation of the index plate

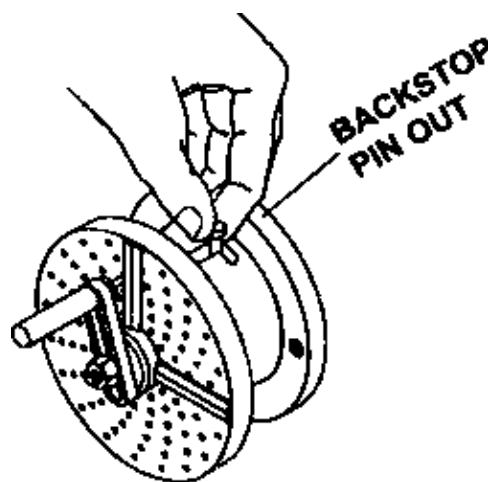
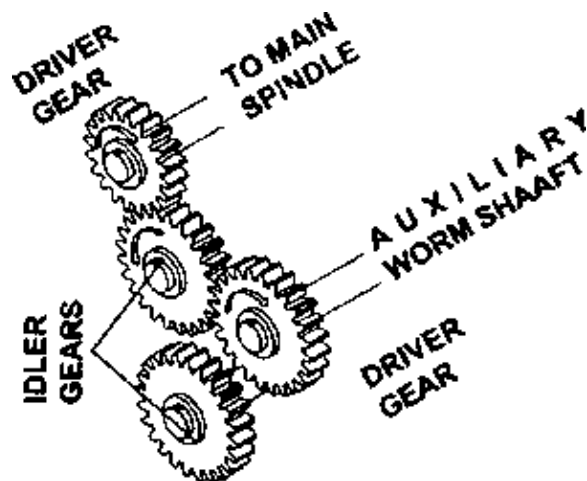

Elements of a straight bevel gear

TR 01 05 15 22 02

δ_a = FACE ANGLE
 δ_f = ROOT ANGLE
 δ' = PITCH CONE ANGLE

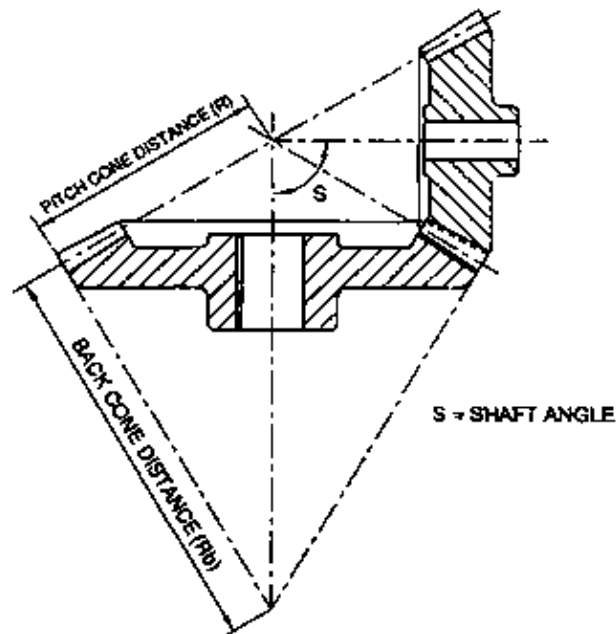
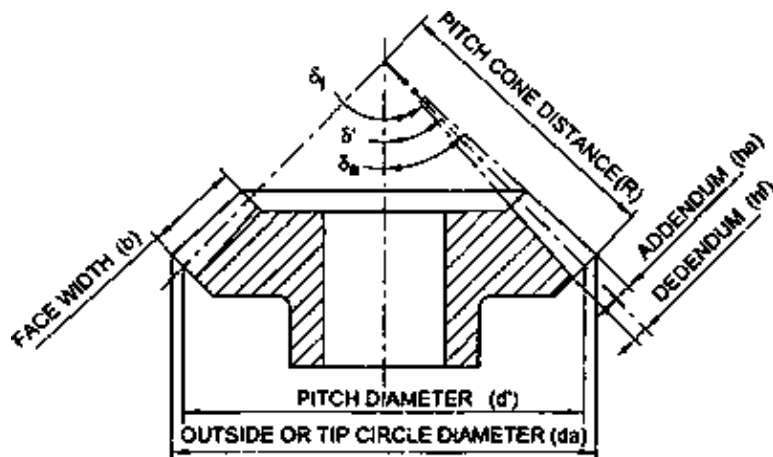

Module (m), number of teeth (z) and the pitch cone angle (δ') are the elements only be given normally for milling bevel gears. Other elements and data are to be calculated using different formulae.

Essential elements/datas which are mainly required for milling a bevel gears:

Virtual number of teeth (z^1) for cutterselection, offset of first flank, first angular movement of the blank, offset of the second flank (from first offset position) and second angular movement of the blank (from first offset position).

Surface texture measurement

TR 01 05 26 23 02

All the manufactured surfaces are not fully perfect. There are ups and downs. These ups and downs are varying in heights and spaces.

Difference in appearance/feeling of touch/sliding/reflection due to the ups and downs in a surface is called surface texture.

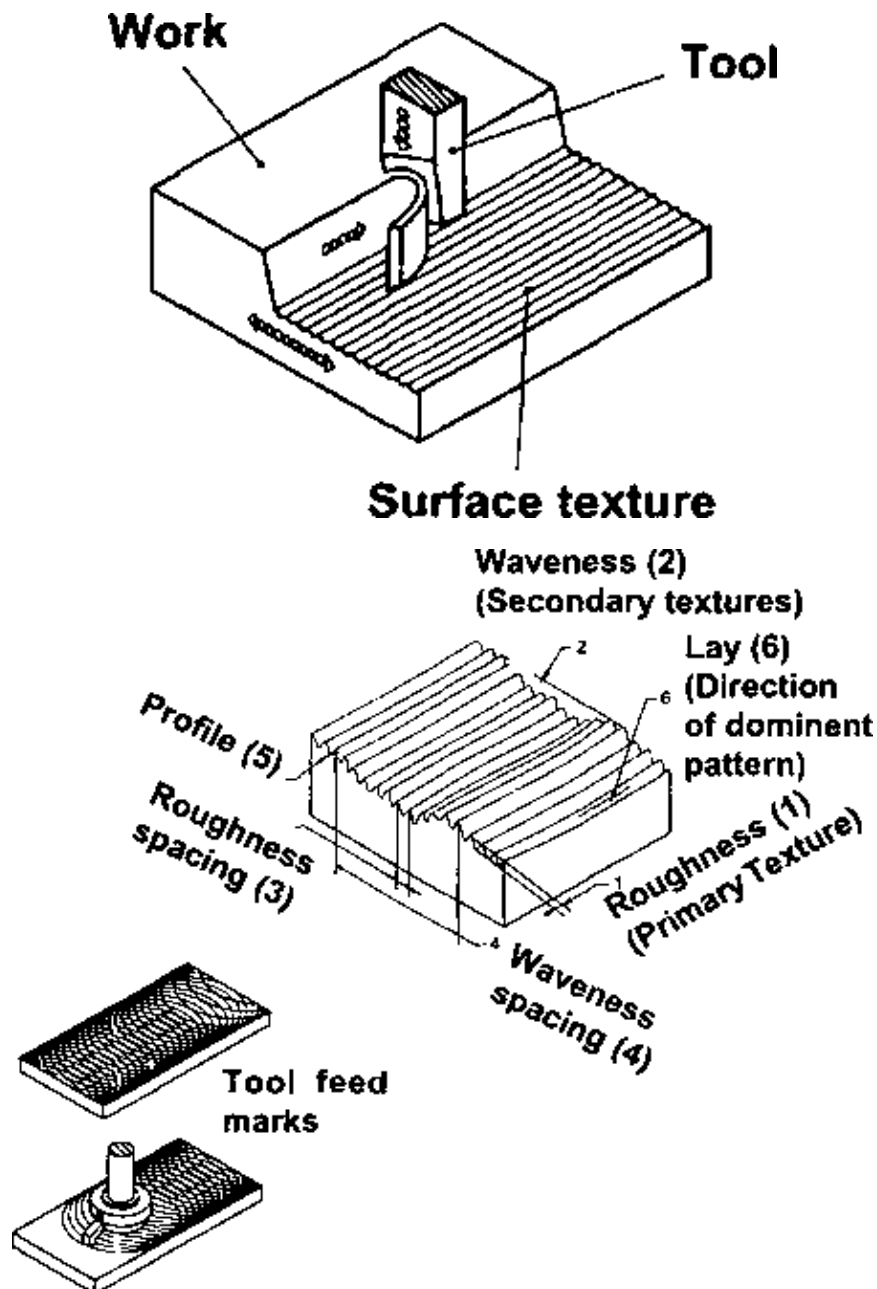

The components of surface texture are surface roughness (Primary texture) and waviness (secondary texture).

Surface roughness is the irregularities of short wave lengths, are generated due to the cutting action of tools, abrasives etc.

Waviness is a component of surface having irregularities of longer wave lengths. Surface roughness is superimposed on this component. This is resulting from the deflection of machine or work, vibration, etc.

Quality of surface texture is numerically expressed by Ra value. This Ra value is expressed in 0.000001 m or Mm). This can also indicated in the corresponding grade numbers ranging from N_1 to N_{12} .

Average line

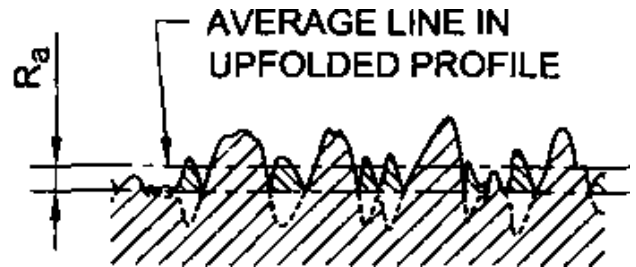

Average (mean) line is placed cutting through the surface profile considering cavities below and the material above are equal.

Cavities below the average line brought above and a profile curve (a fold of bottom half) is drawn. A new average (meanline) is then calculated and drawn. The distance between the two lines is the Ra value of the surface.

Methods of indicating surface roughness

TR 01 05 26 24 02

1. Surface represented by this basic symbol is under consideration.

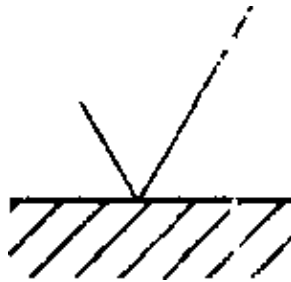

1a Add a roughness value or roughness grade symbol to make the symbol more meaningful.

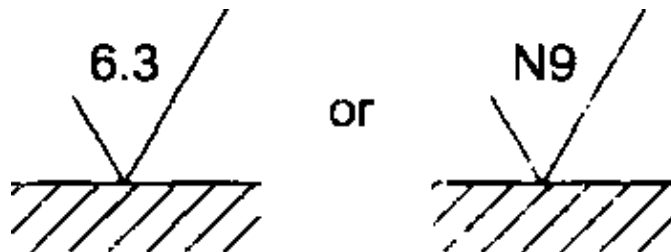

2. Added bar to the basic symbol expresses that removal of material by machining.

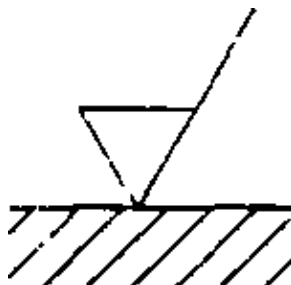

2a Added roughness value/roughness grade symbol specifies the expected surface finish and the type of machining.

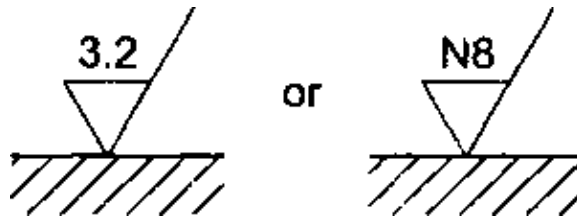

3 Added circle to the basic symbol expresses that the removal of material is not permitted.

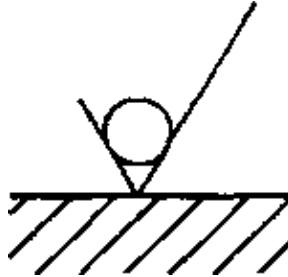

3a Added roughness value/roughness grade symbol tells that the surface finish can be obtained by processes like electro plating, lapping, etc.

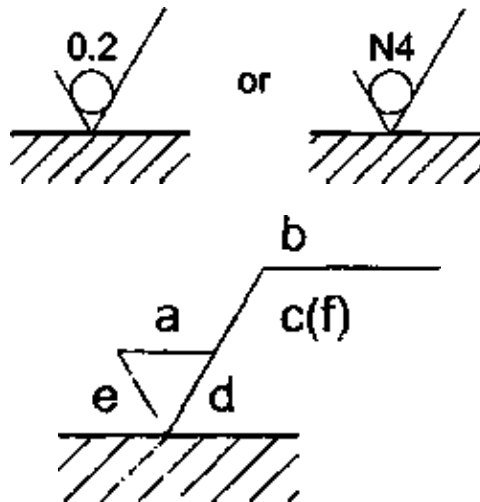

a = Roughness value Rain micron or roughness grade number N1 to N12 or roughness value in jam.

b = Production method (Treatment coating)

c = Sampling length in mm

d = direction of lay

e = Machining allowance in mm

f = Other roughness value (in bracket)

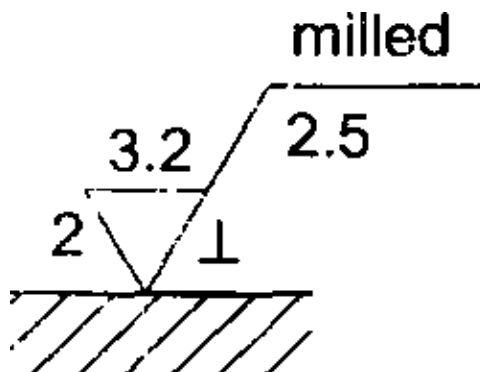

Surface finish of N3 and N5 has to be achieved on the specified surfaces and on the other surfaces achieve only N7.

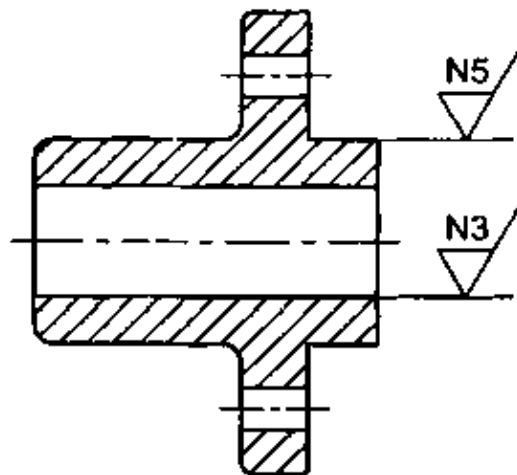
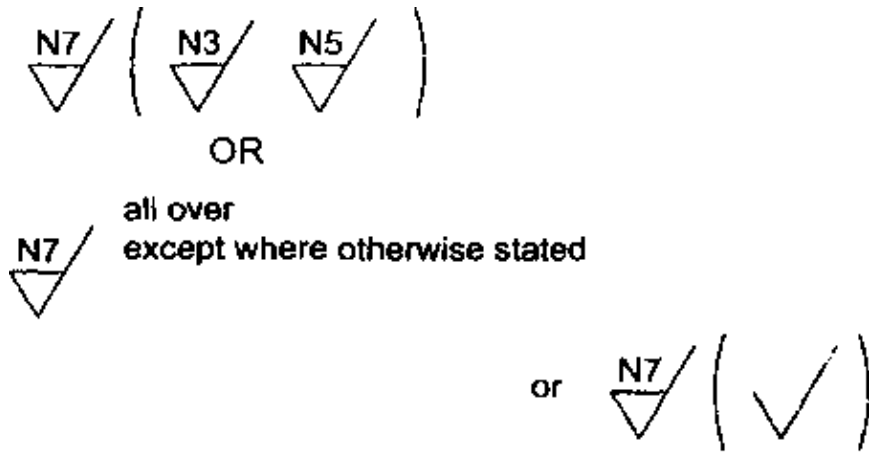

Worm and worm wheel

TR 01 05 29 25 02

Worm and Worm wheel drive is used to connect two non-parallel, non-intersecting shafts which are at right angles to each other.

Mainly used for large speed reduction.

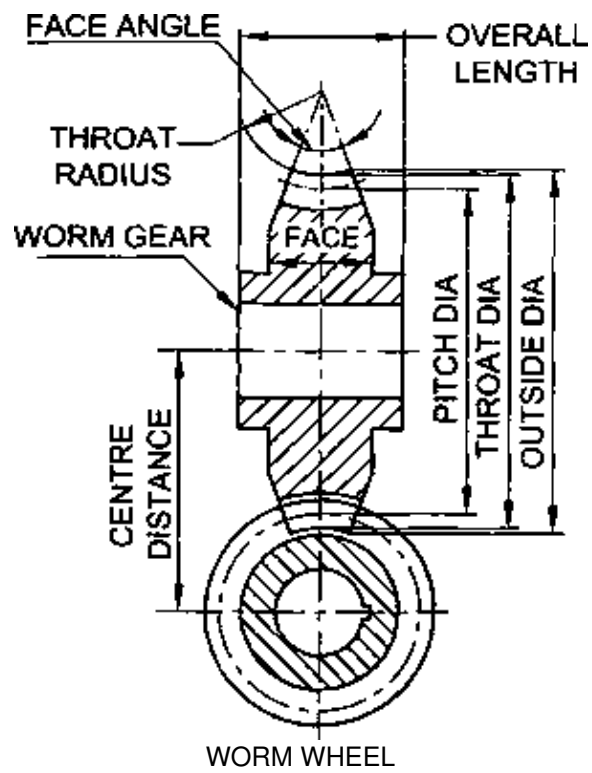
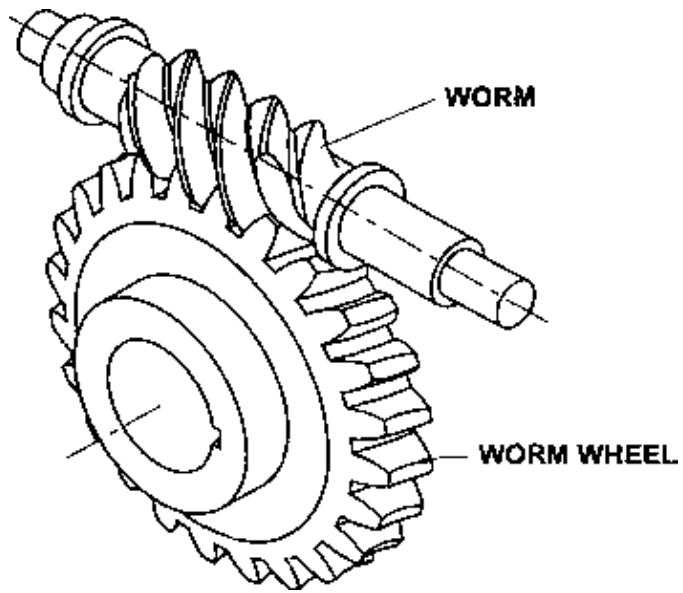

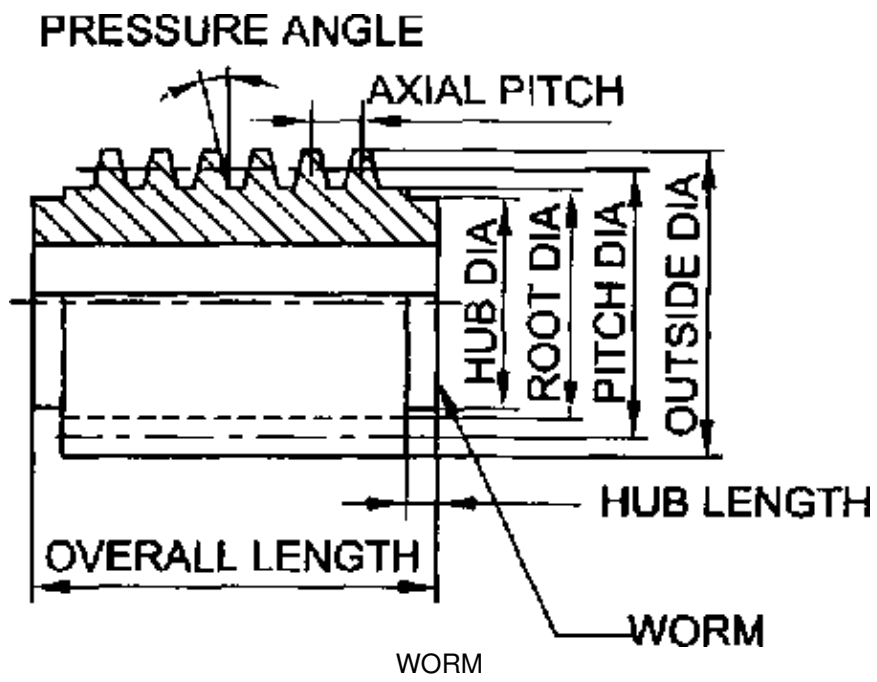

Turner 1st Year – Transparencies

Table of Contents

Turner 1st Year – Transparencies	1
<u>Hand Hammers – Applications</u>	1
<u>Vernier Caliper Parts and Principles</u>	1
<u>Reading of Vernier Caliper</u>	2
<u>Micrometer parts and graduations</u>	3
<u>Micrometer reading</u>	4
<u>Vernier bevel protractor parts & application</u>	5
<u>Bevel protractor reading</u>	6
<u>Vernier height gauge</u>	7
<u>Inside Micrometer</u>	8
<u>Depth Micrometer</u>	9
<u>Grinding wheel marking</u>	10
<u>Cutting speed, feed and R.P.M. of Drills</u>	11
<u>Drill parts and angles</u>	12
<u>Fundamentals of limits and fits</u>	13
<u>Classes of fit</u>	14
<u>Shaft basis and hole basis system of limits and fits</u>	15
<u>Centre lathe and its parts</u>	16
<u>Lathe parts</u>	17
<u>Lathe chucks</u>	18
<u>Collet chucks</u>	19
<u>Lathe centres and their application</u>	20
<u>Lathe centres and their application</u>	21
<u>Different methods of taper turning (Form tool and compound rest)</u>	22
<u>Different methods of taper turning (Tails tock set over and taper turning attachment)</u>	23
<u>Alignment of lathe centres</u>	24

Turner 1st Year – Transparencies



CENTRAL INSTRUCTIONAL
MEDIA INSTITUTE, CHENNAI



ANINDO – GERMAN PROJECT

Directorate General of Employment & Training, Ministry of Labour, Govt. of India.

Developed by
CENTRAL INSTRUCTIONAL MEDIA INSTITUTE
in collaboration with DEUTSCHE GESELLSCHAFT FUER TECHNISCHE ZUSAMMENARBEIT (GTZ)
Germany

P.O. Box 3142. 76. GST Road. Guindy. Chennai – 600 032. Phone: 234 5256. 234 5257. Fax (0091 44) 234 2791

Hand Hammers – Applications

TR 01 01 01 01 93

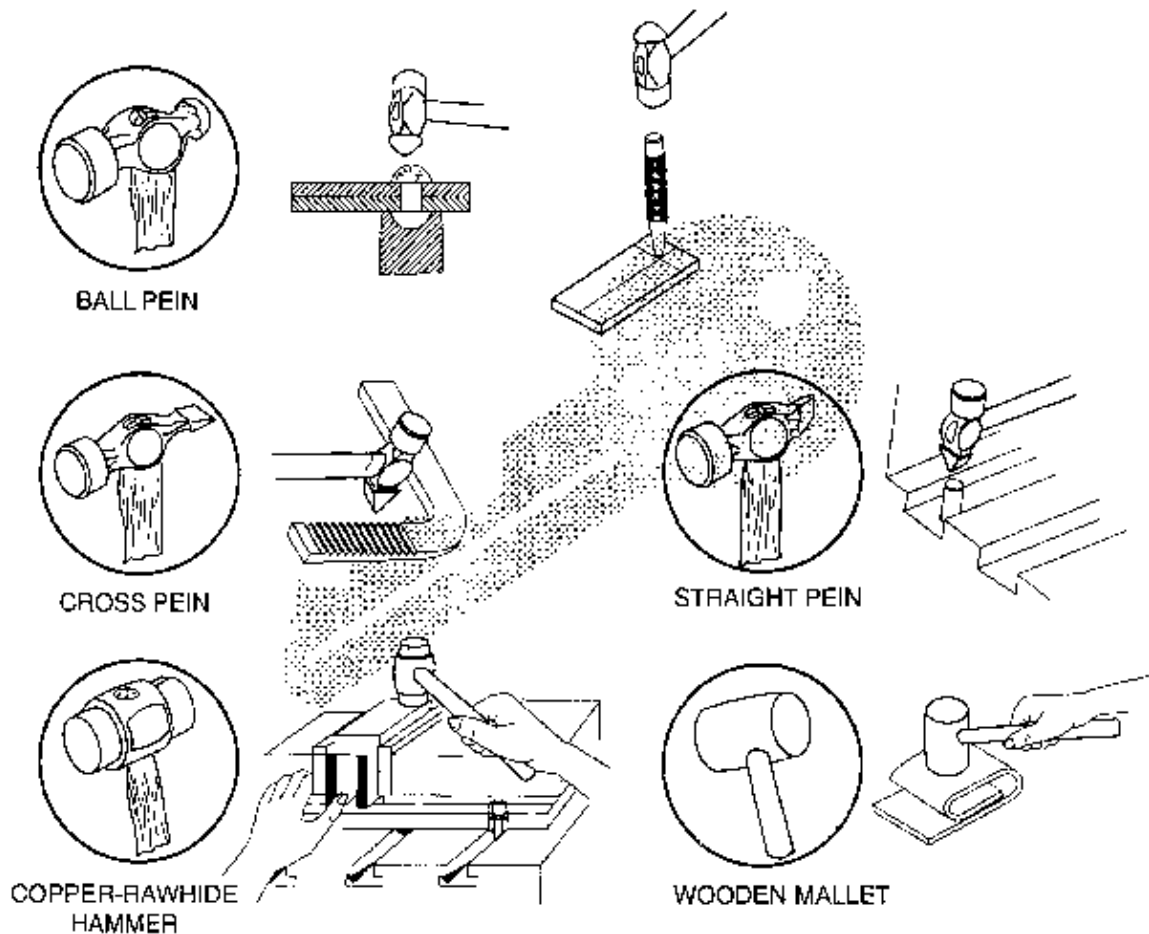

HAND HAMMERS – APPLICATIONS

Vernier Caliper Parts and Principles

TR 01 02 01 01 93

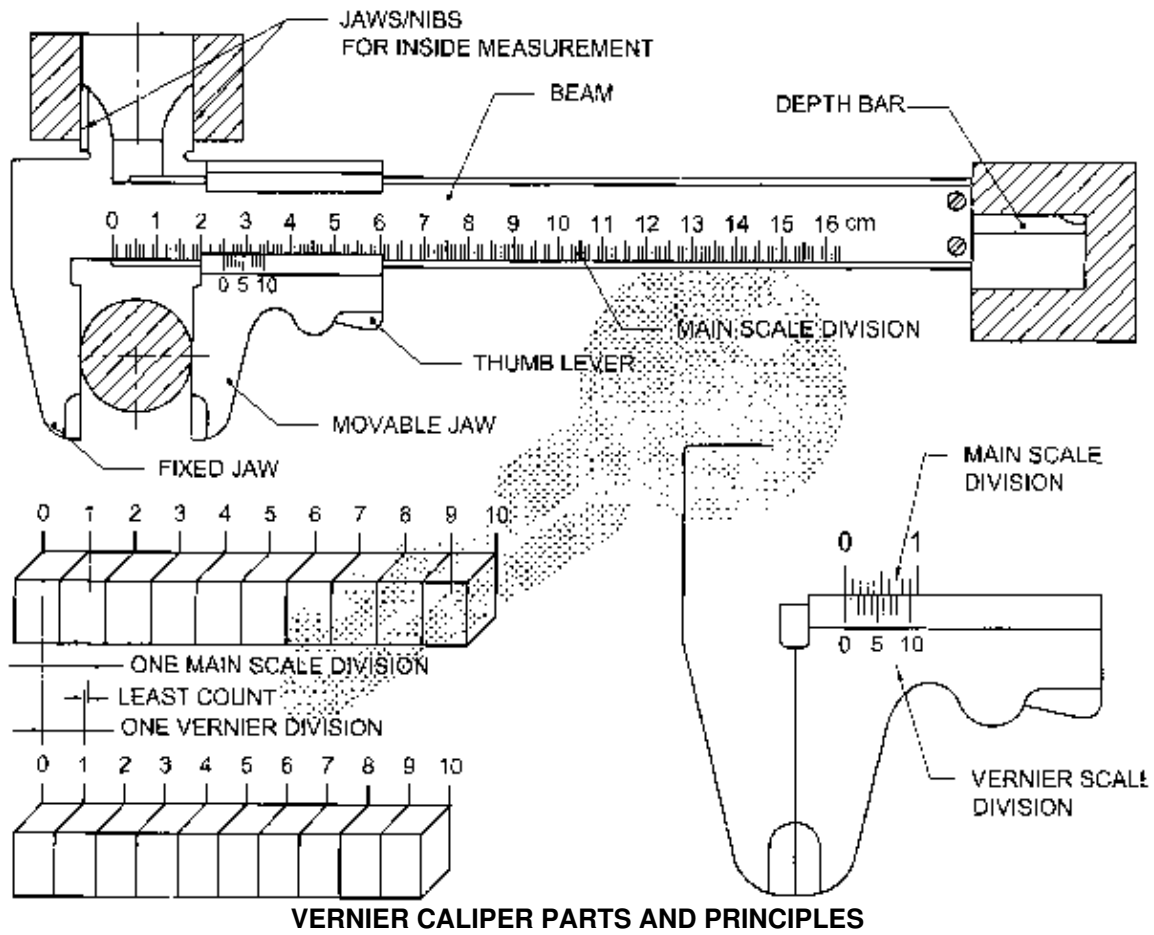

Reading of Vernier Caliper

TR 01 02 01 02 93

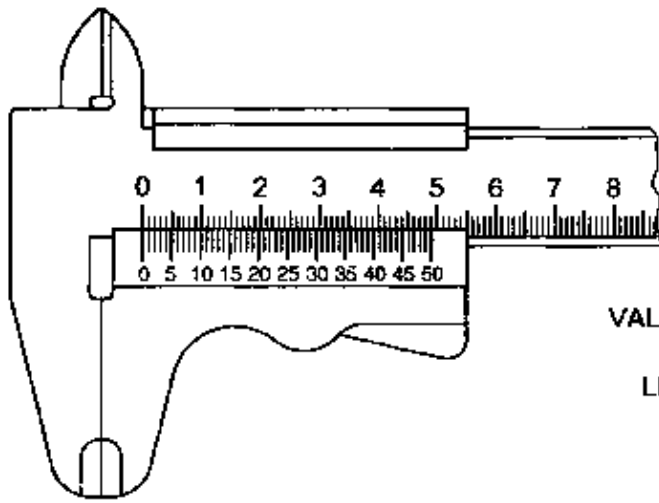

49 MAIN SCALE DIVISIONS
ARE DIVIDED INTO 50
VERNIER SCALE DIVISIONS

$$\text{VALUE OF 1 VSD} = \frac{49}{50} \text{ mm}$$

$$\text{LEAST COUNT} = 1 \text{ MD} - 1 \text{ VSD}$$

$$= 1 - \frac{49}{50}$$

$$= \frac{1}{50} = 0.02 \text{ mm}$$



$$\text{MAIN SCALE READING} = 10.00 \text{ mm}$$

$$\text{VALUE OF COINCIDING } \left. \begin{array}{l} \text{VERNIER DIVISION} \end{array} \right\} = 00.40 \text{ mm}$$

$$\text{READING} = 10.40 \text{ mm}$$

ASSIGNMENTS:-

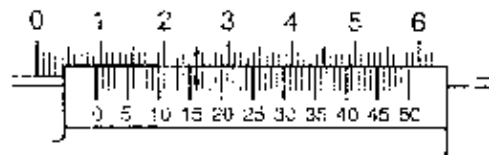

$$\text{A READING} = 9.32 \text{ mm}$$

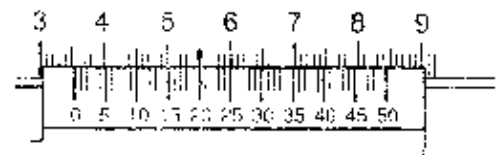

$$\text{B READING} = 35.40 \text{ mm}$$

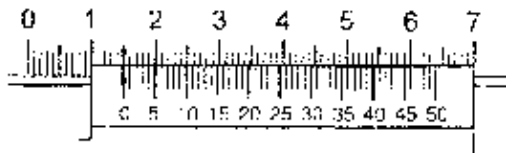

$$\text{C READING} = 15.00 \text{ mm}$$

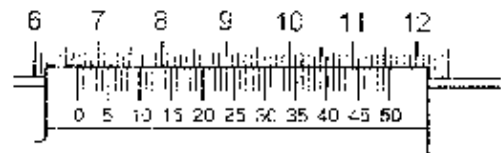

$$\text{D READING} = 66.80 \text{ mm}$$

READING OF VERNIER CALIPER

Micrometer parts and graduations

TR 01 02 02 01 93

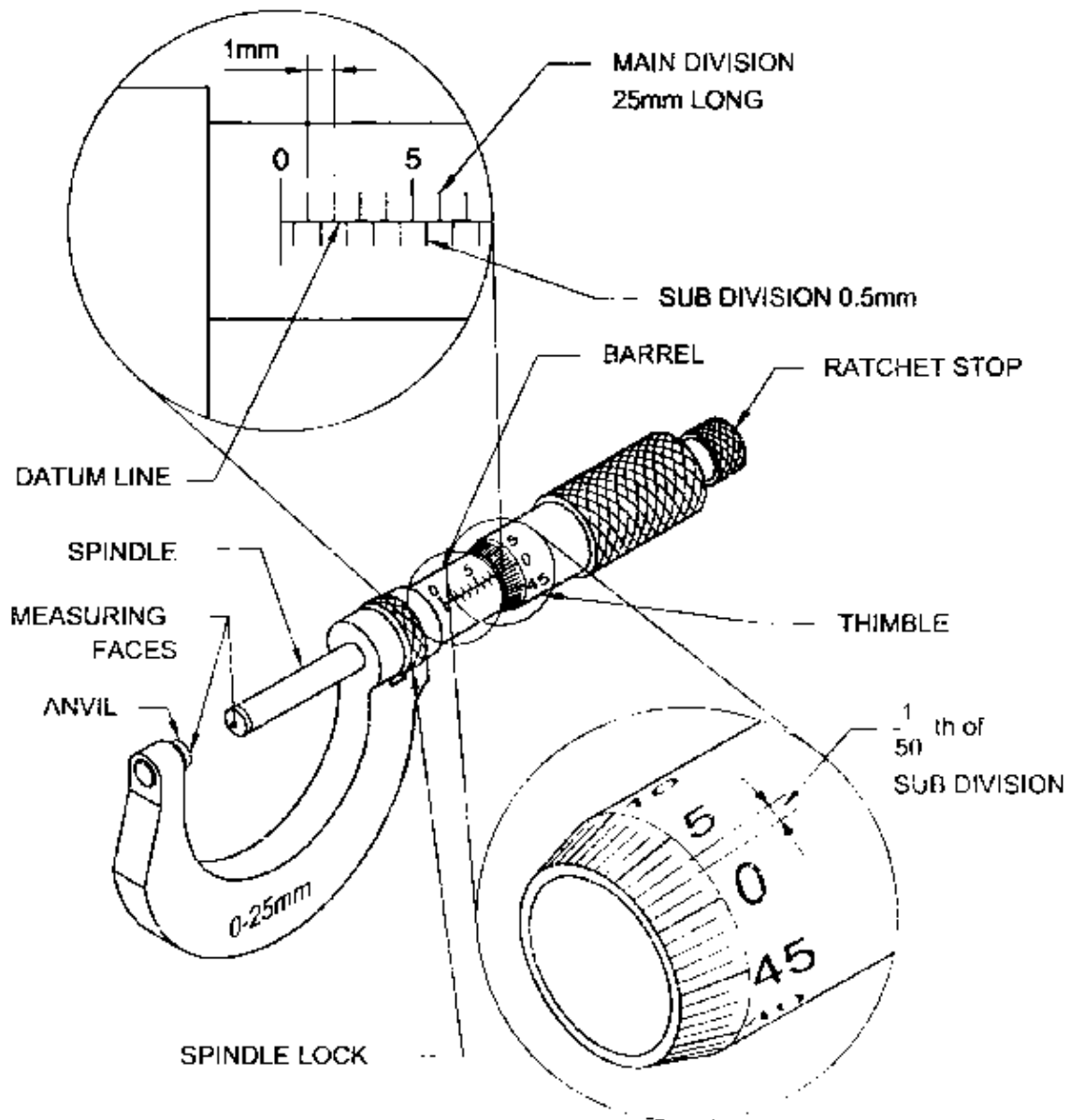

$$\begin{aligned} \text{LEAST COUNT} &= \frac{1}{50} \text{th of } 0.5\text{mm} \\ &= \boxed{0.01 \text{ mm}} \end{aligned}$$

MICROMETER PARTS AND GRADUATIONS

Micrometer reading

TR 01 02 02 02 93

MICROMETER GRADUATIONS

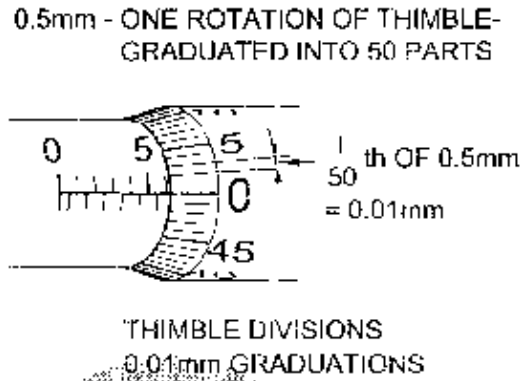
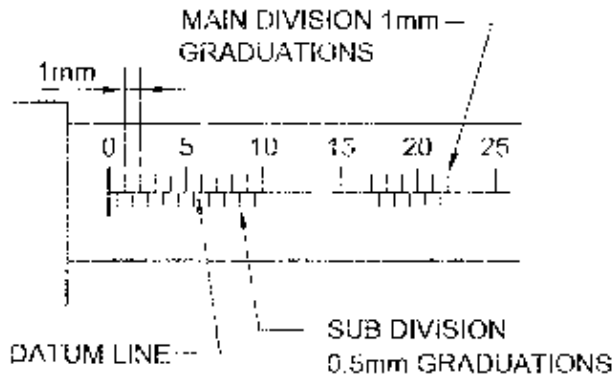

MICROMETER READING

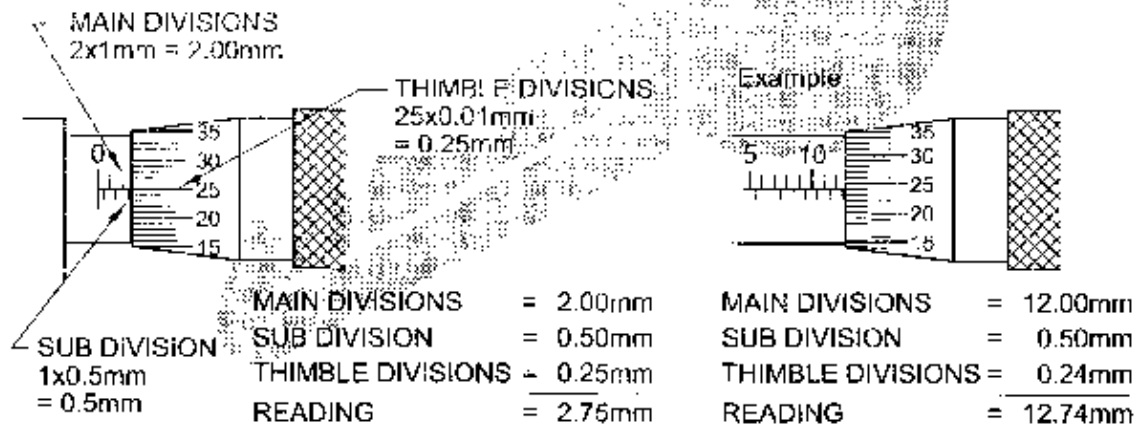

ASSIGNMENTS:-

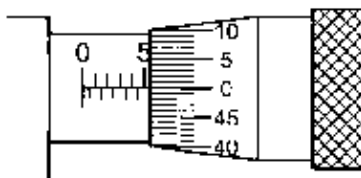

A READING **5.50 mm**

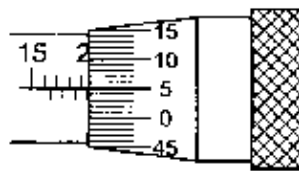

B READING **19.55 mm**

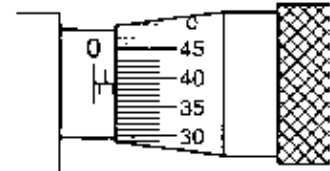

C READING **1.89 mm**

MICROMETER READING

Vernier bevel protractor parts & application

TR 01 02 03 01 93

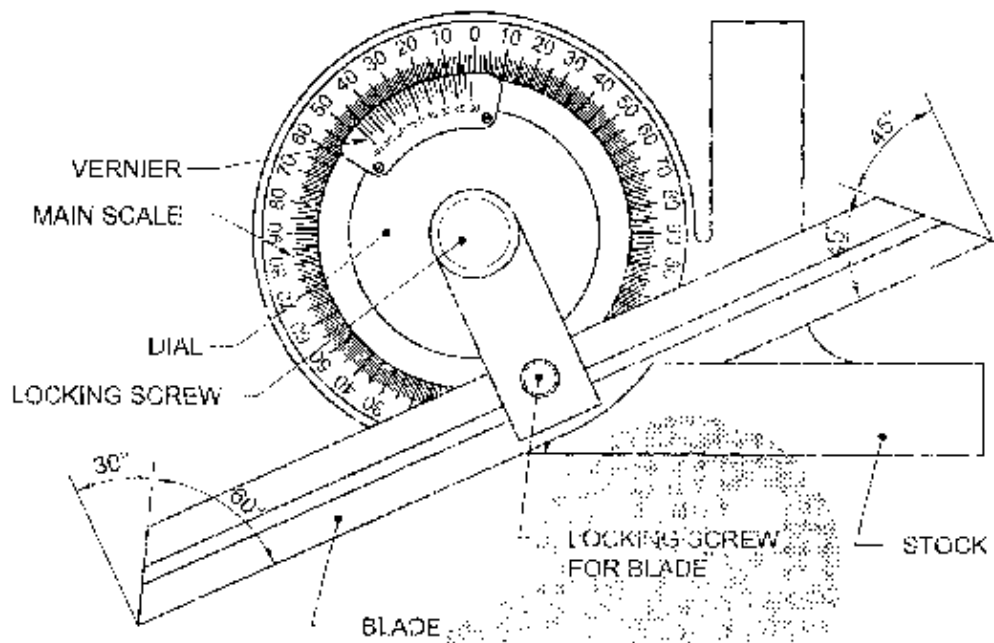

APPLICATIONS:

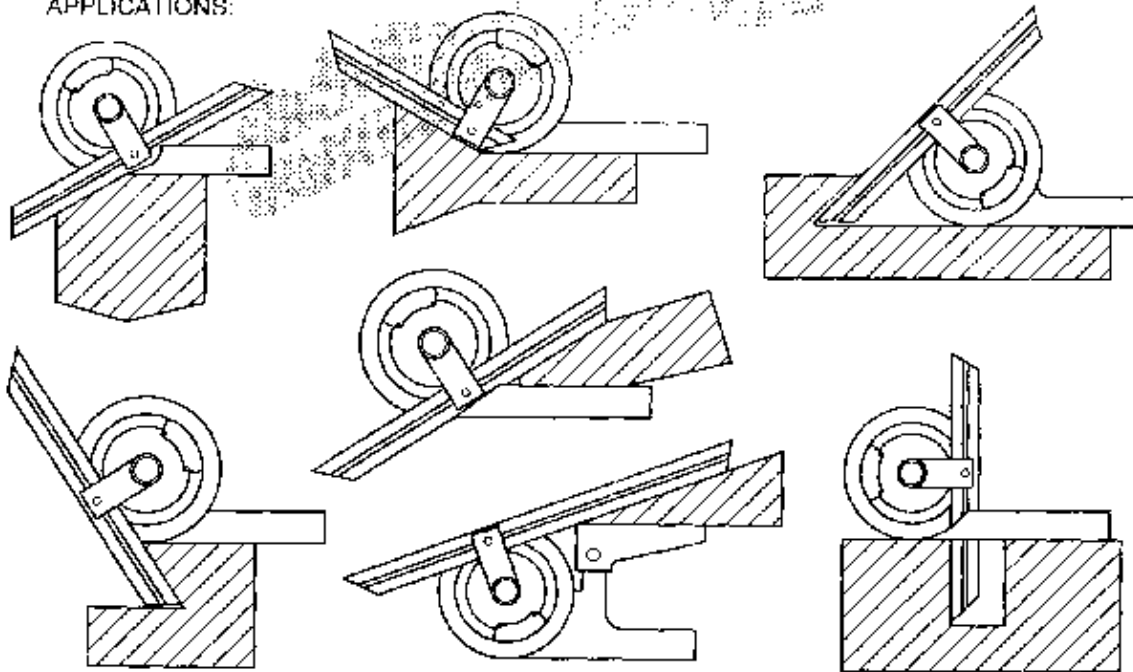

VERNIER BEVEL PROTRACTOR PARTS & APPLICATION

Bevel protractor reading

TR 01 02 03 02 93

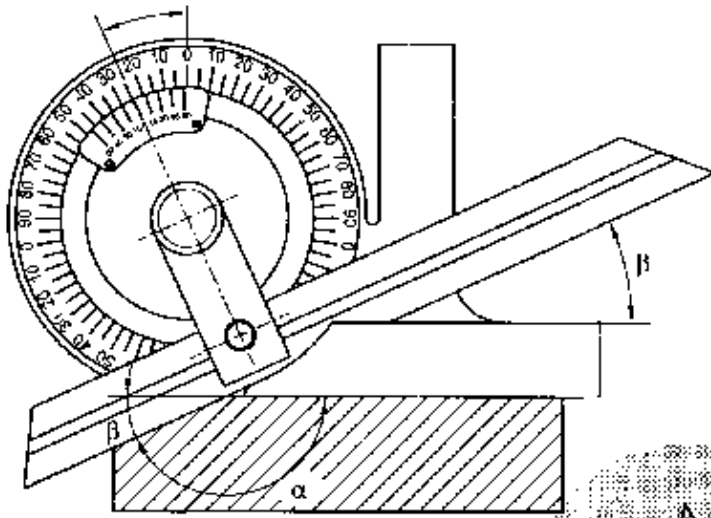

OBTUSE ANGLE
 $\alpha = 180^\circ \beta$

ASSIGNMENTS:-



A READING

$\alpha - \beta = 54^\circ 25'$

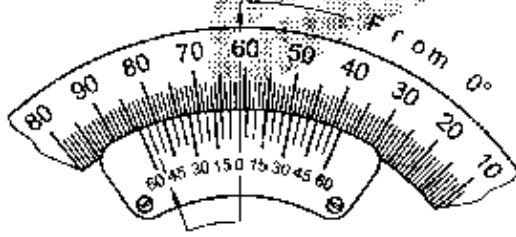

B READING

$\alpha = 180^\circ \beta$
 $= 180^\circ 60' 55'$
 $119^\circ 5'$

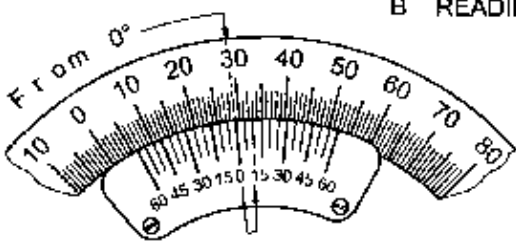

C READING

$29^\circ 10'$

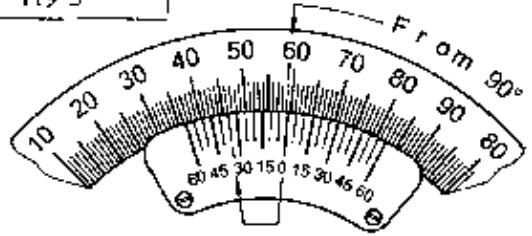

D READING

$30^\circ 35'$

BEVEL PROTRACTOR READING

Vernier height gauge

TR 01 02 04 01 93

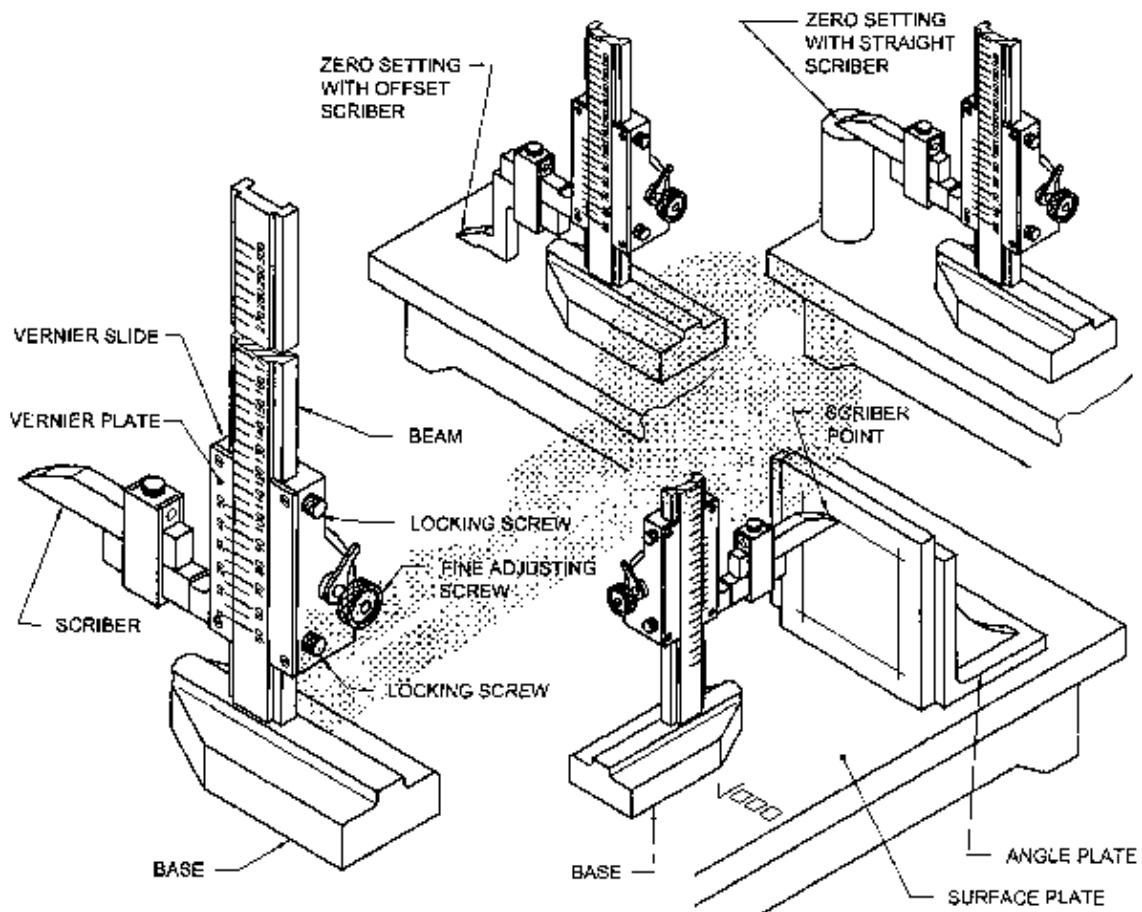

VERNIER HEIGHT GAUGE

Inside Micrometer

TR 01 02 05 01 93

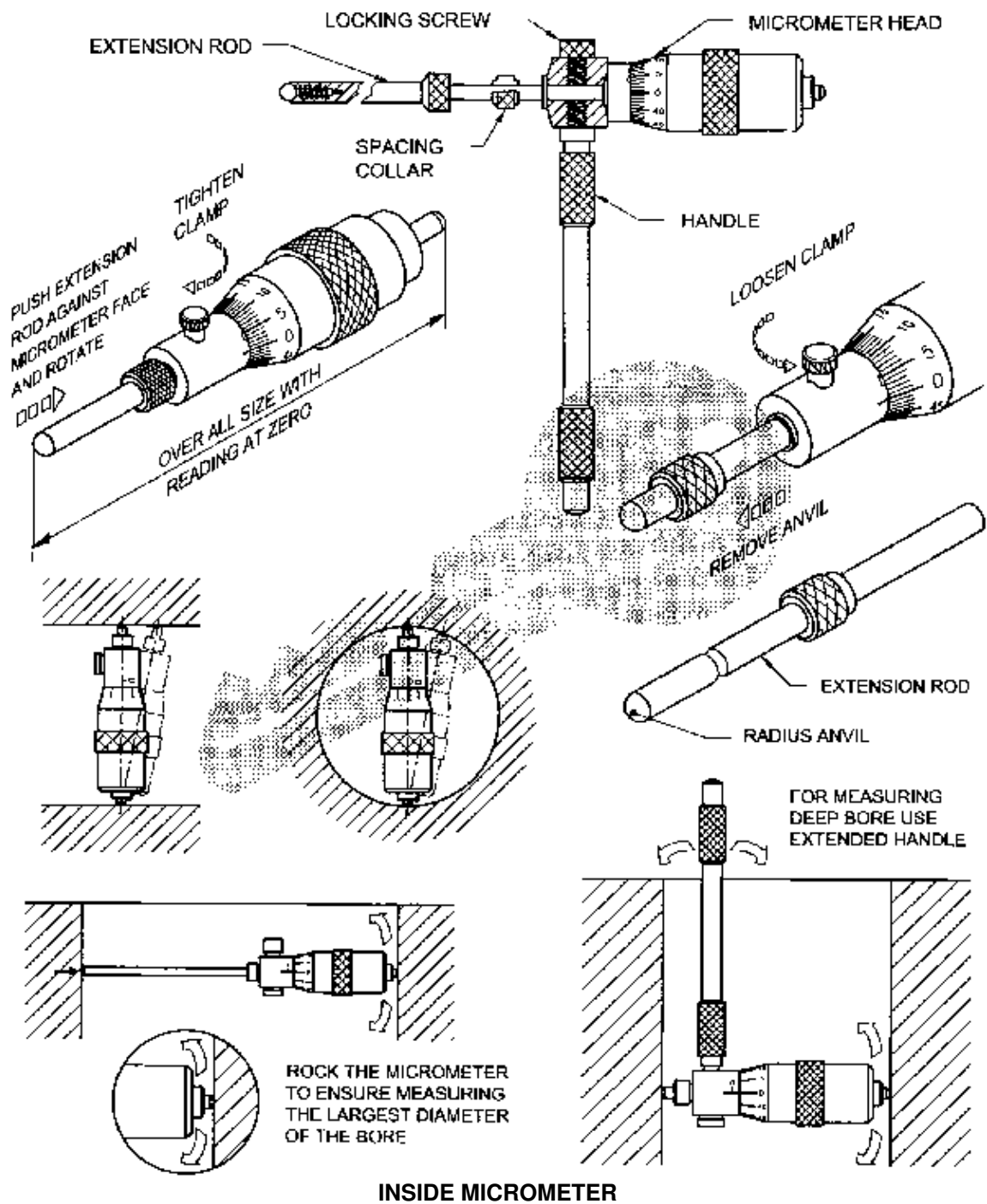

Depth Micrometer

TR 01 02 06 01 93

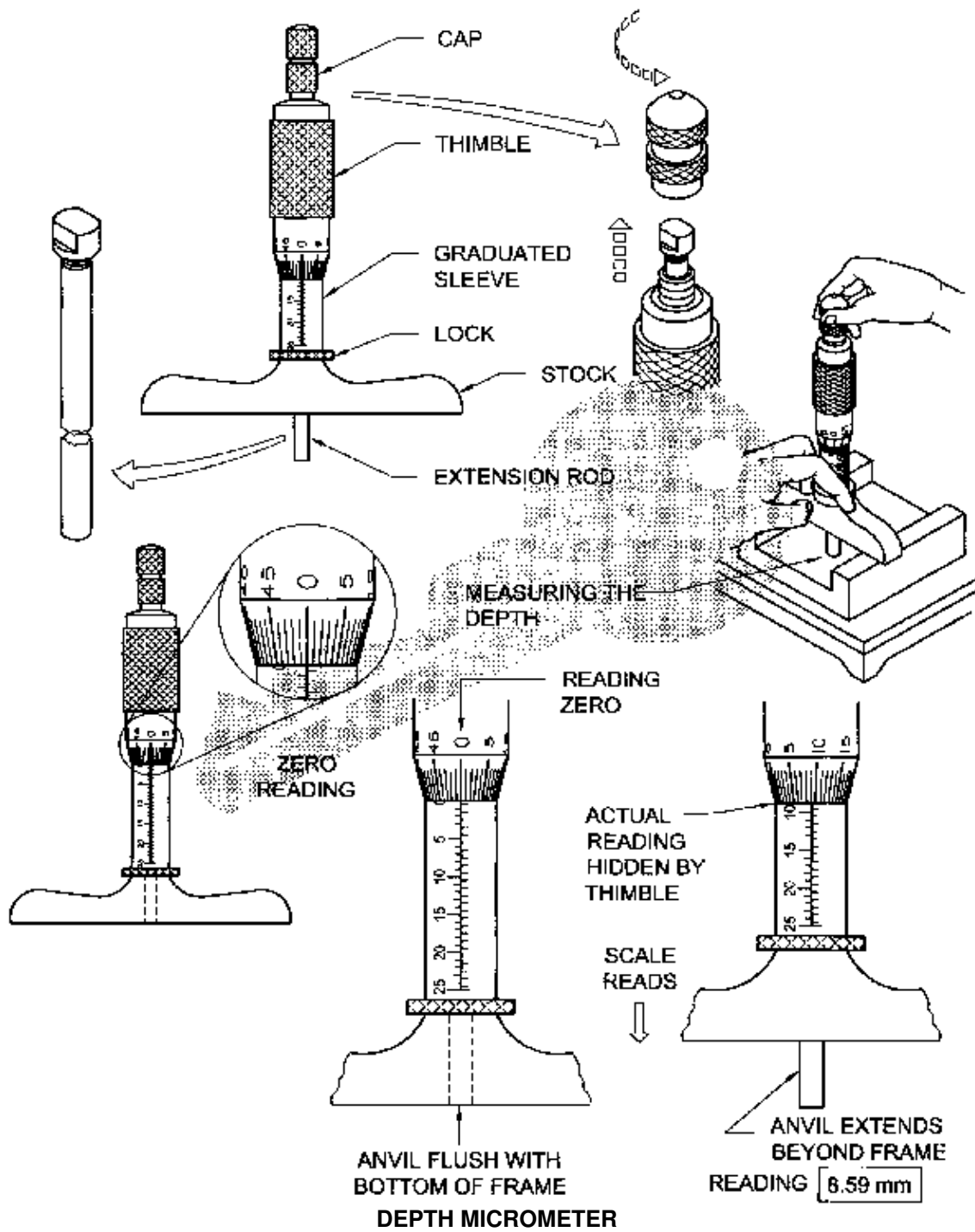

Grinding wheel marking

TR 01 04 01 01 93

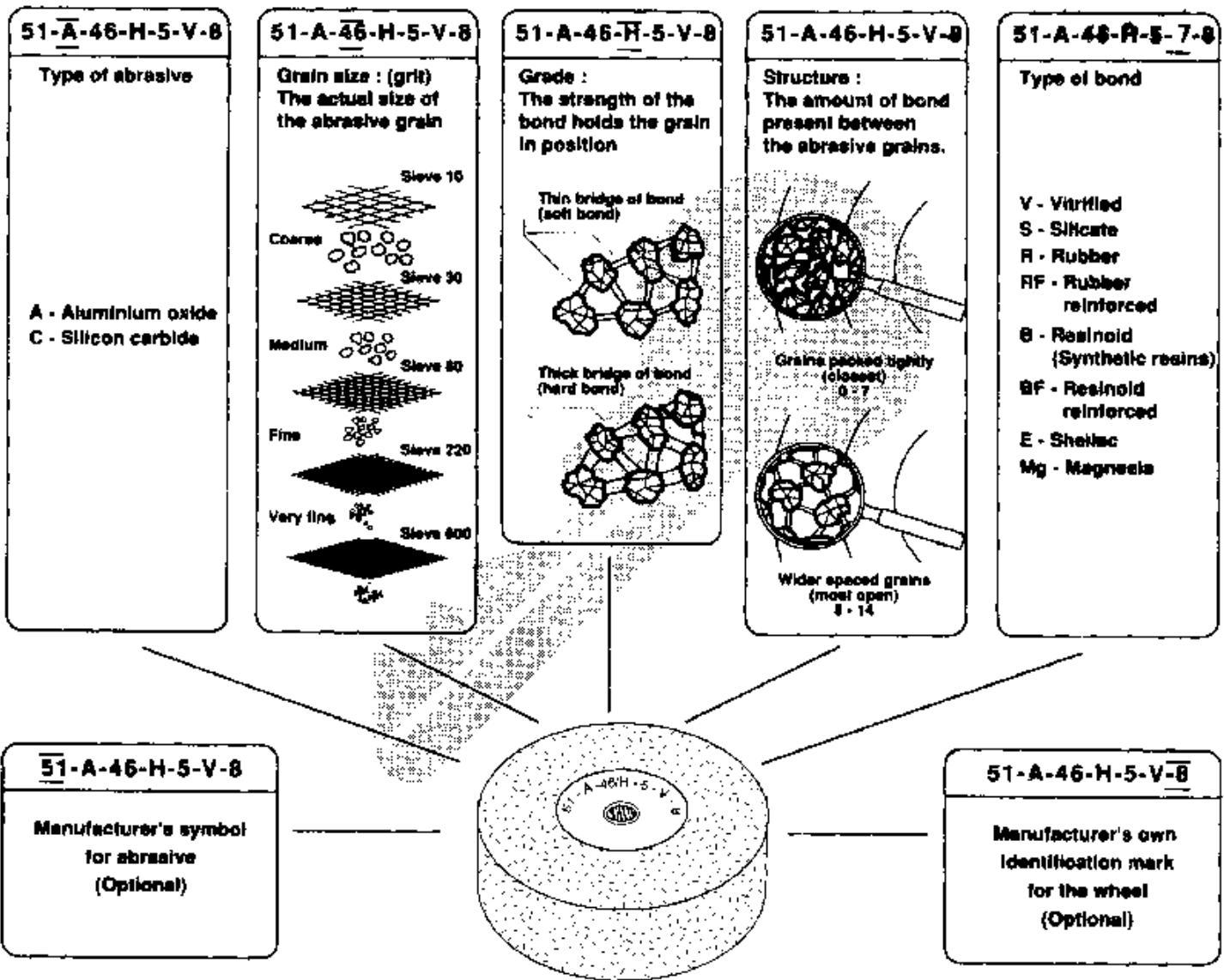

GRINDING WHEEL MARKING

Cutting speed, feed and R.P.M. of Drills

TR 01 05 01 01 93

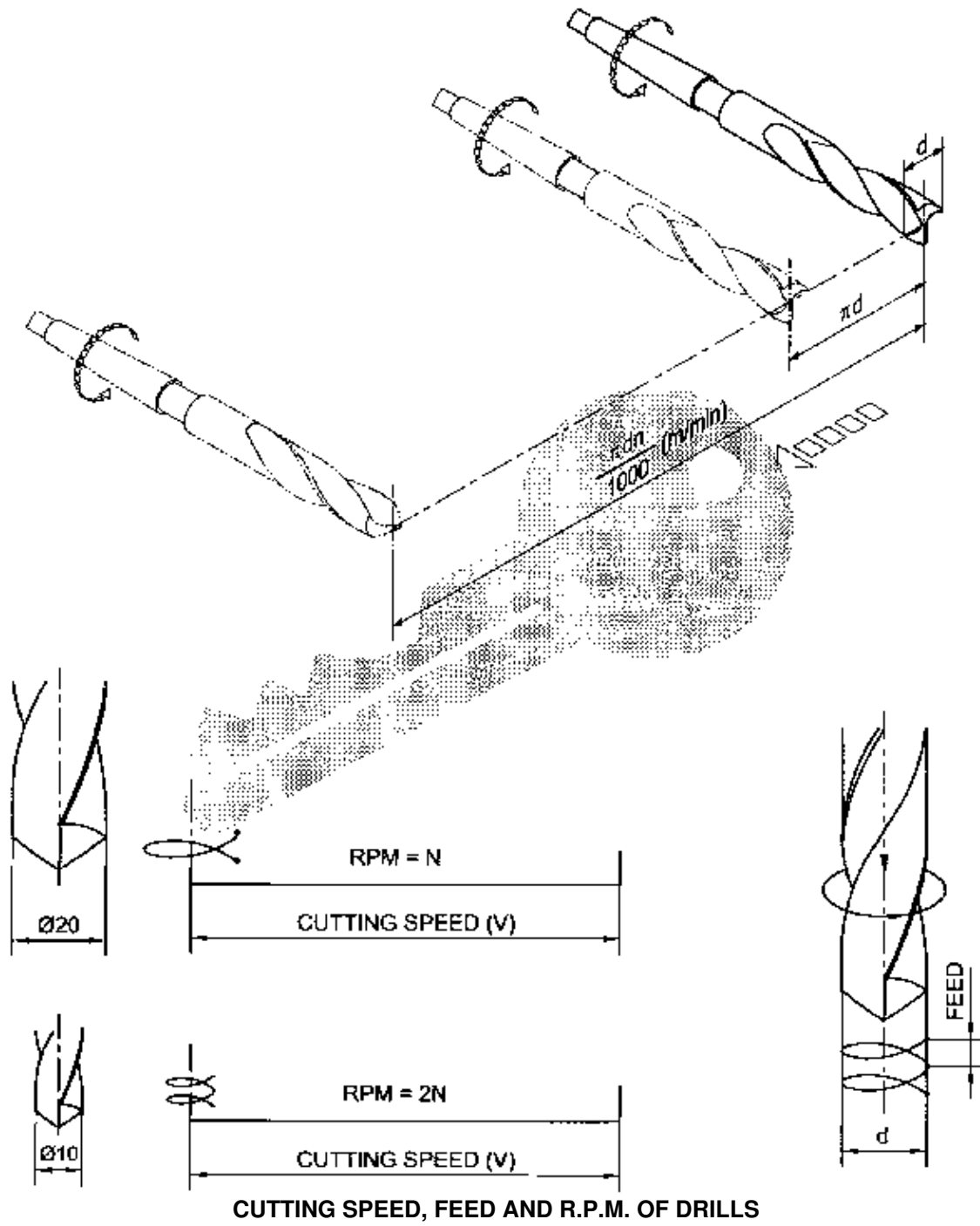

Drill parts and angles

TR 01 05 02 01 93

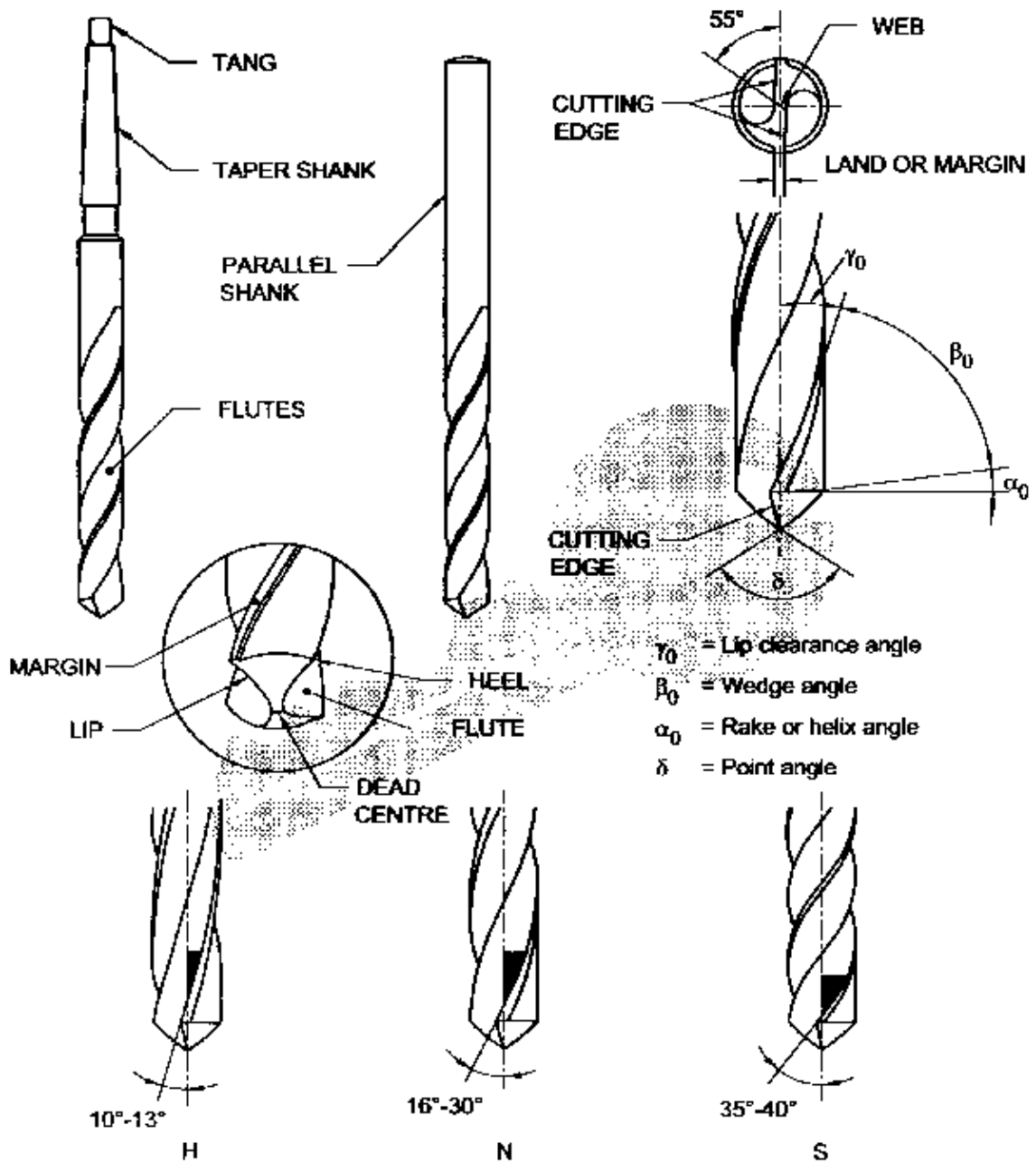

Type H - For hard and tenacious materials.
 Type N - For normal low carbon steels.
 Type S - For soft and tough materials.

DRILL PARTS AND ANGLES

Fundamentals of limits and fits

TR 01 06 01 01 93



**SIMPLIFIED SCHEMATIC
 DIAGRAM OF CLEARANCE FIT**

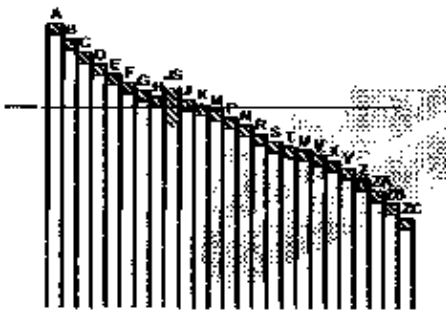
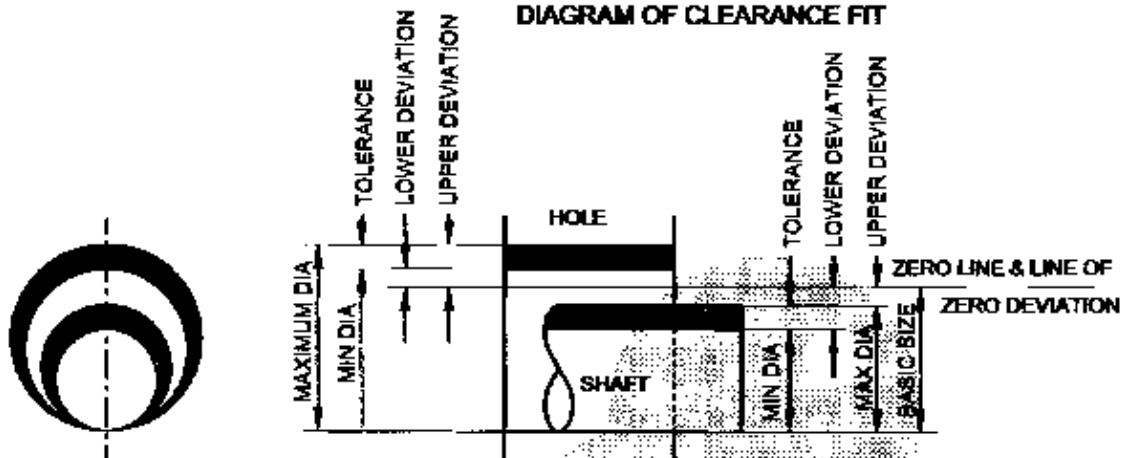

CAPITAL LETTERS INDICATE 25
 FUNDAMENTAL DEVIATION FOR
 HOLES

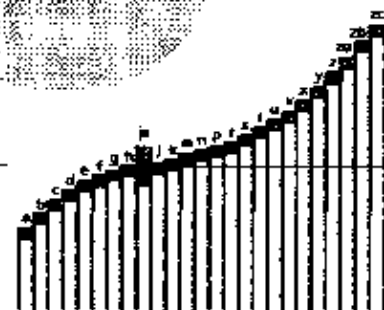

SMALL LETTER INDICATE 25
 FUNDAMENTAL DEVIATION FOR
 SHAFTS

18 GRADES OF TOLERANCES

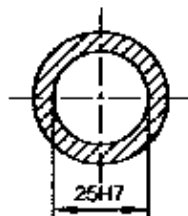

• WHAT DOES 25H7 INDICATE?

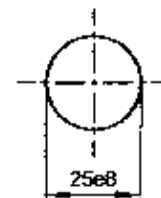
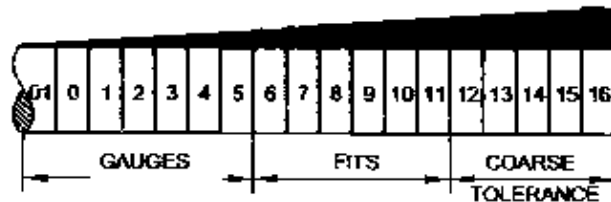

• WHAT DOES 25e8 INDICATE?

FUNDAMENTALS OF LIMITS AND FITS

Classes of fit

TR 01 06 01 02 93

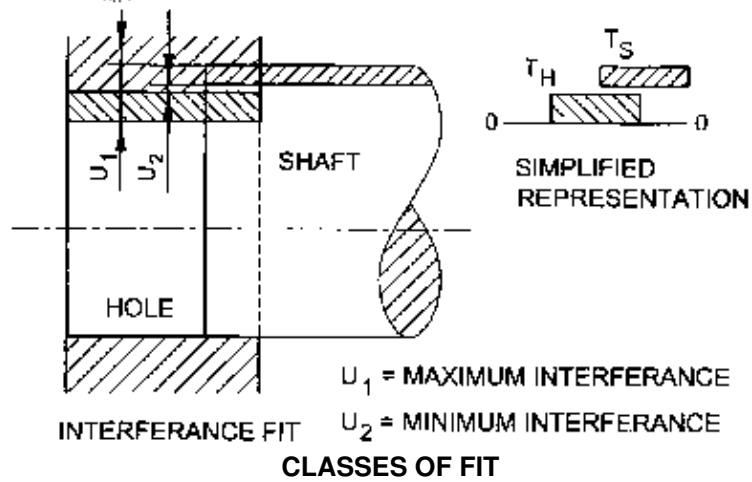
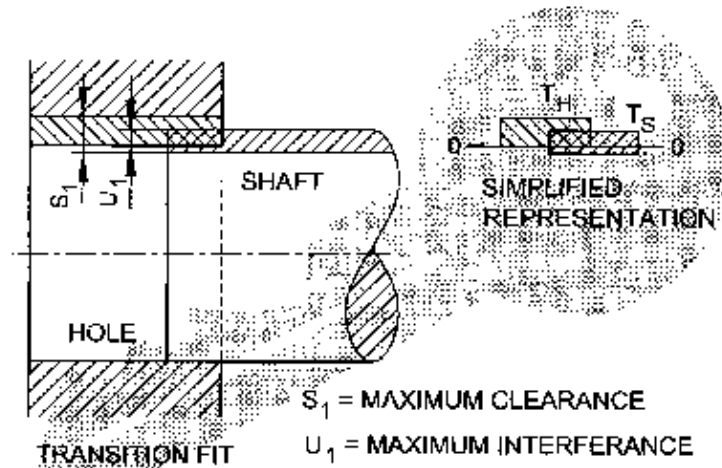
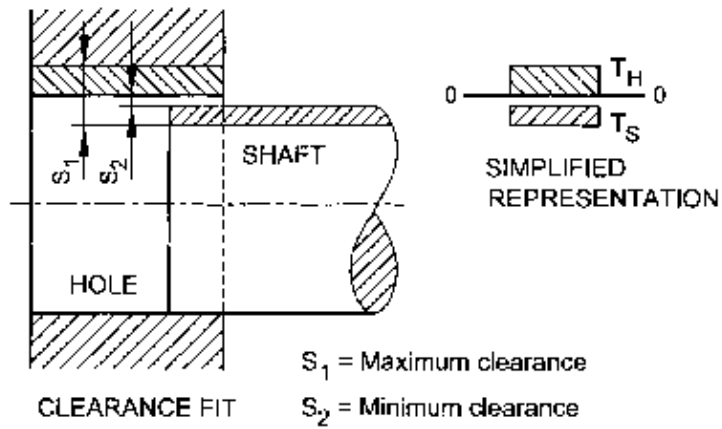

Shaft basis and hole basis system of limits and fits

TR 01 06 01 03 93

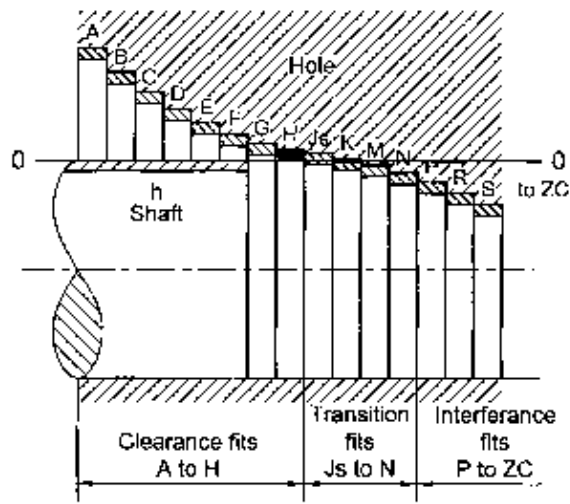

**BASIC SHAFT SYSTEM
(SHAFT BASIS)**

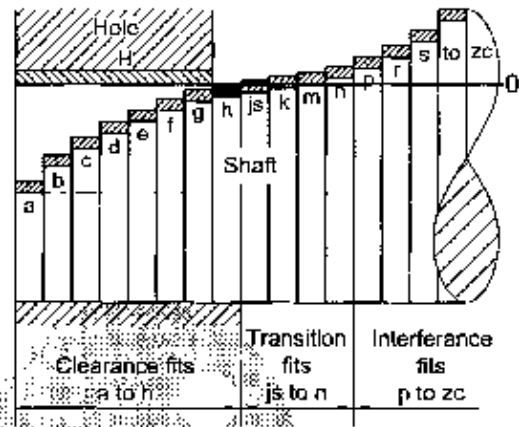

**BASIC HOLE SYSTEM
(HOLE BASIS)**

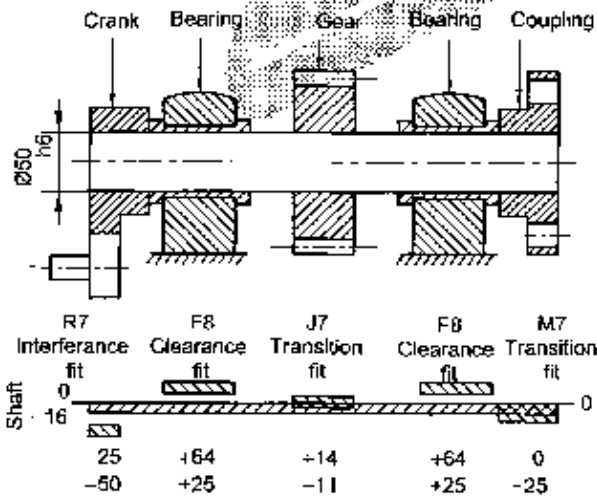

APPLICATION OF THE BASIC SHAFT SYSTEM

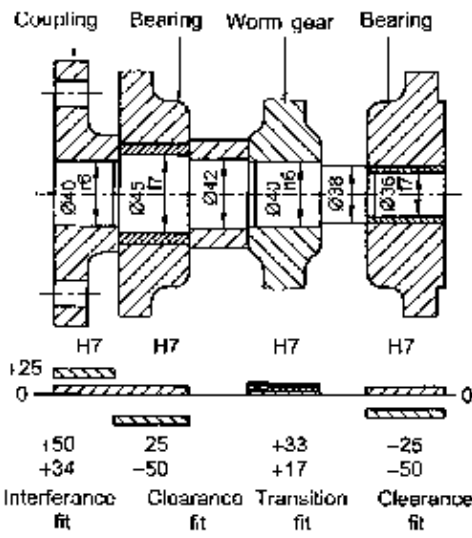

APPLICATION OF THE BASIC HOLE SYSTEM

SHAFT BASIS AND HOLE BASIS SYSTEM OF LIMITS AND FITS

Centre lathe and its parts

TR 01 12 01 01 93

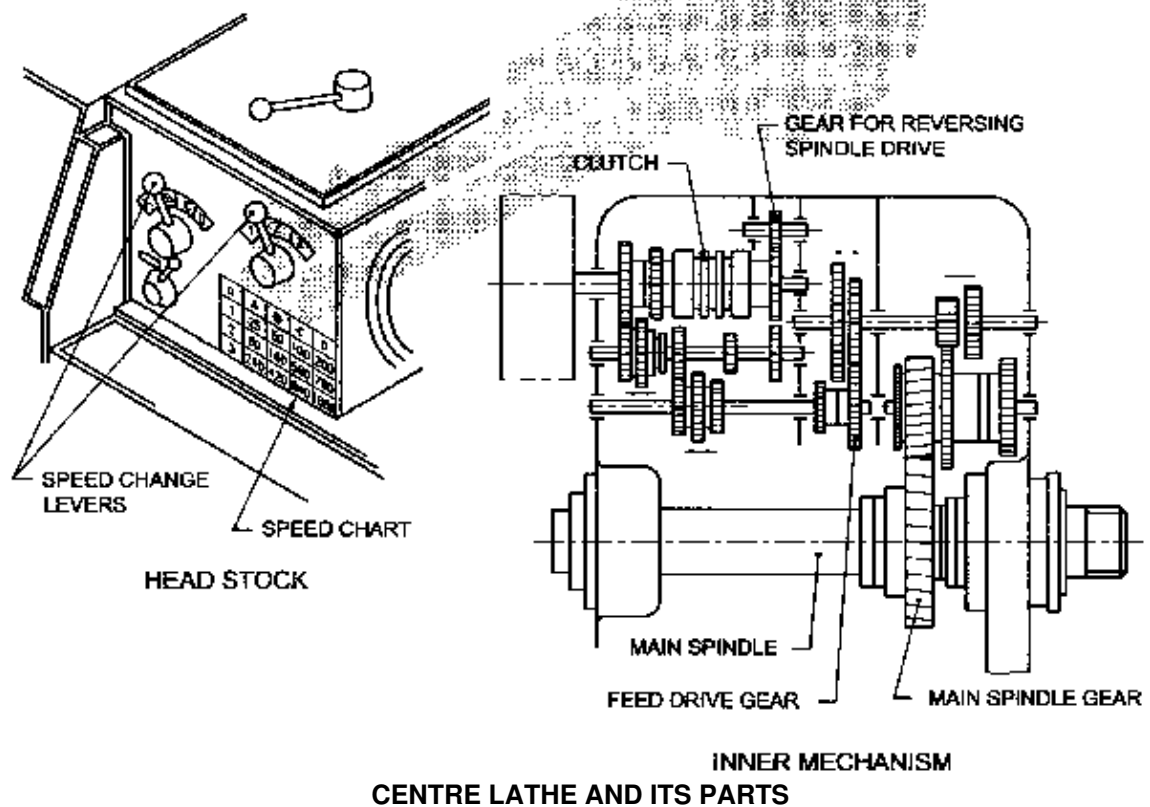
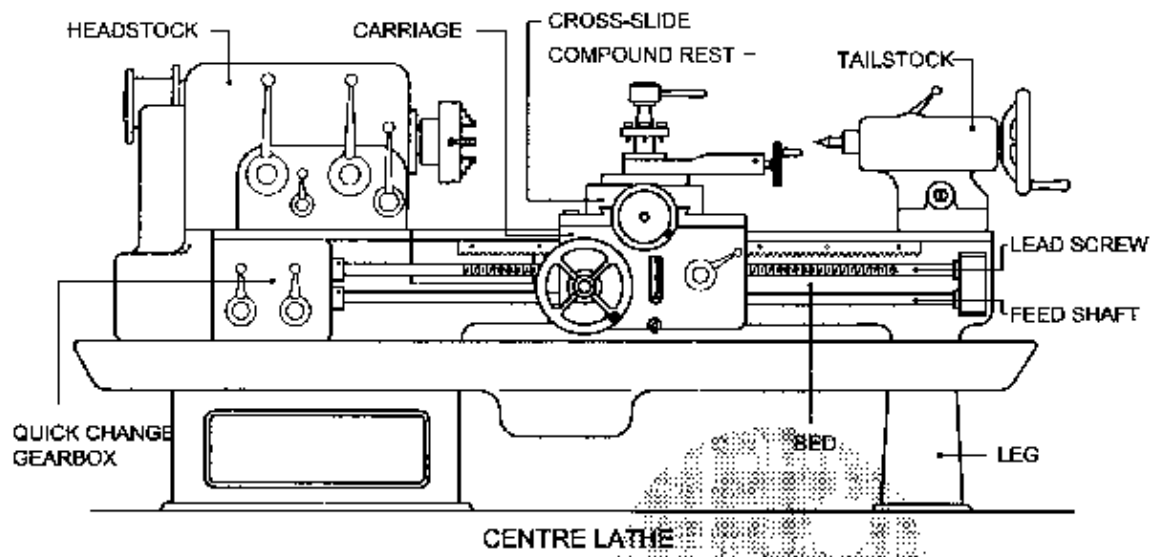

Lathe parts

TR 01 12 03 02 93

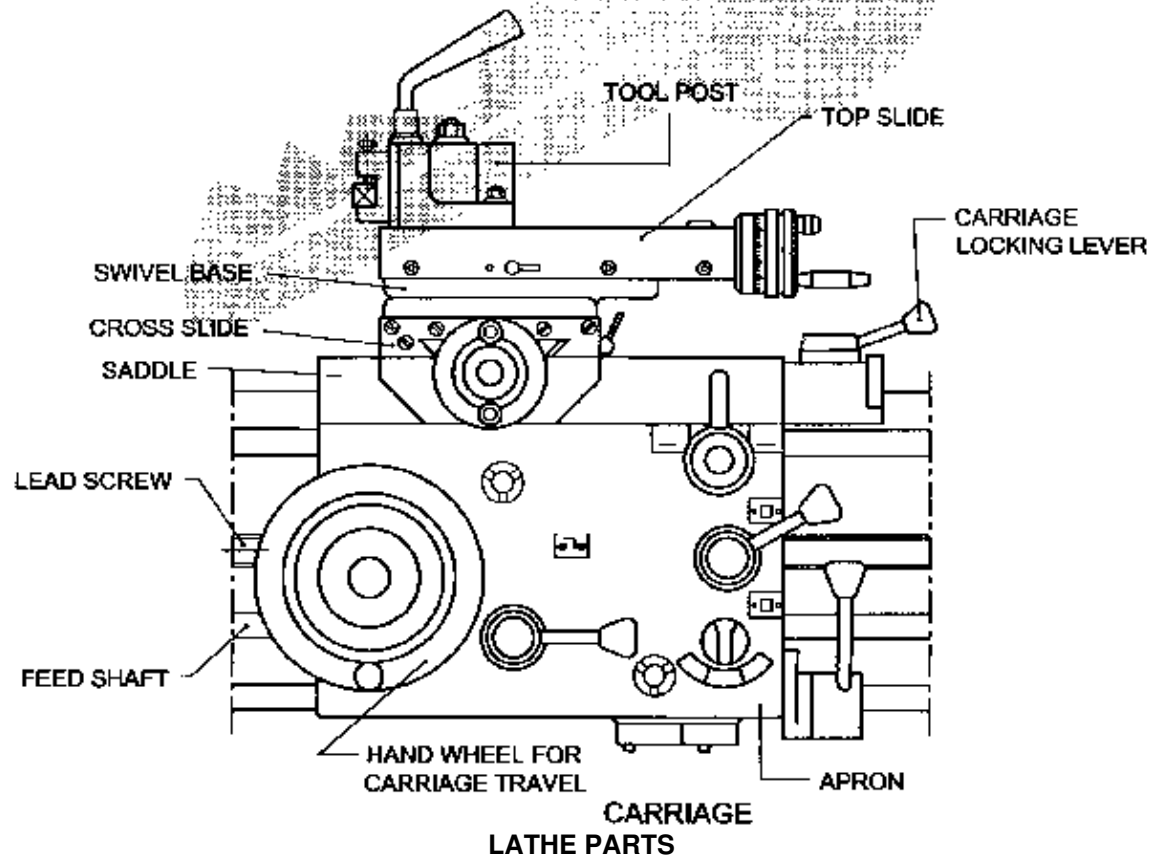
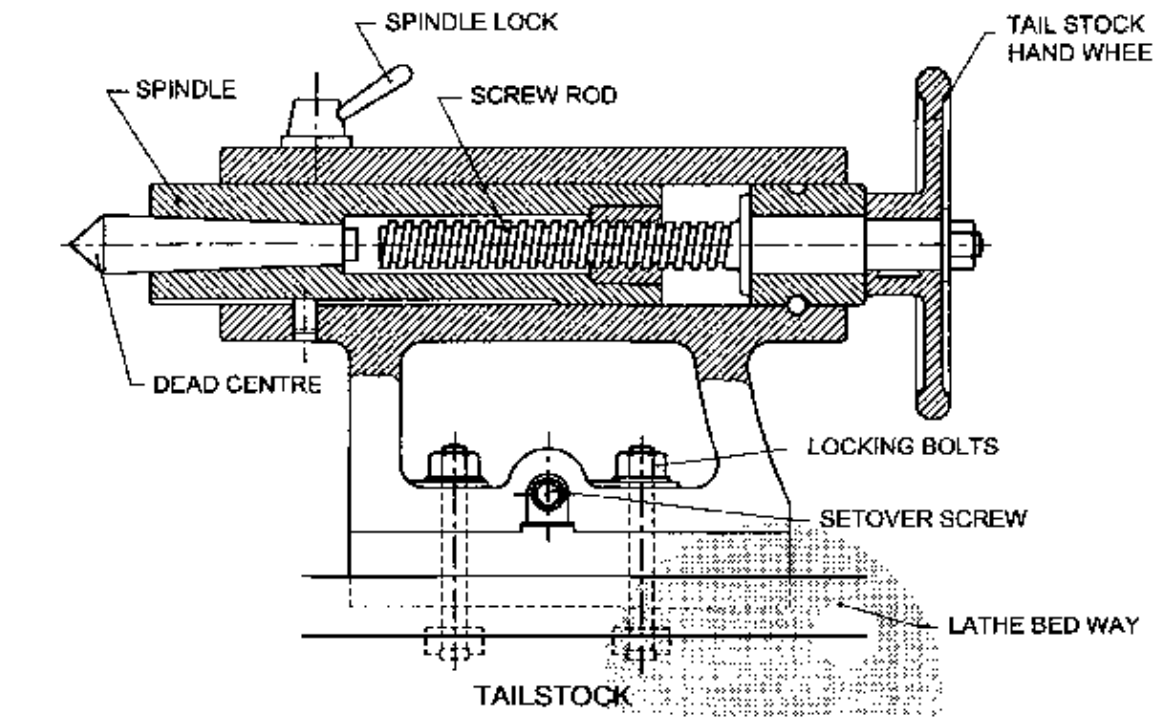

Lathe chucks

TR 01 13 01 01 93

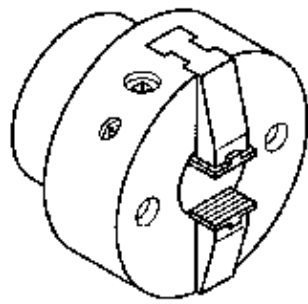

TWO JAW CHUCK

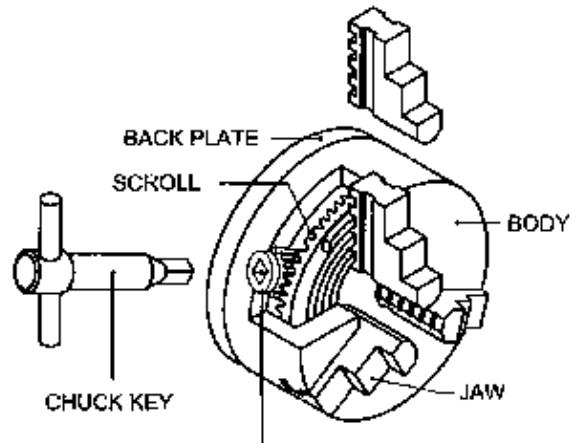

KEY SOCKET AND BEVEL GEAR TO ROTATE SCROLL

THREE JAW CHUCK

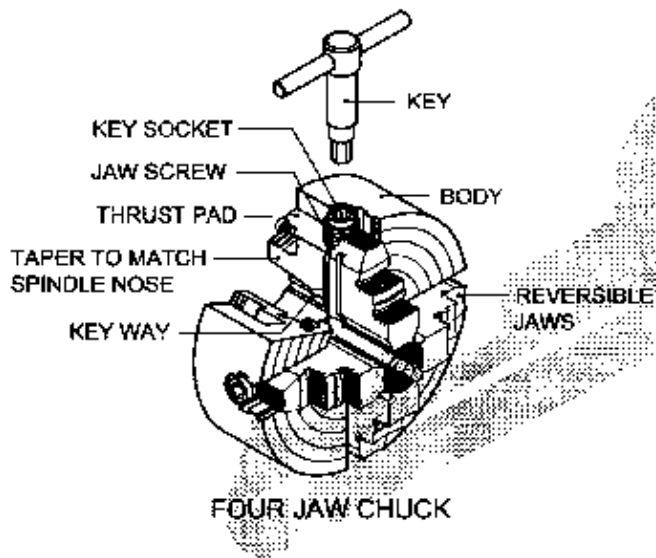

FOUR JAW CHUCK

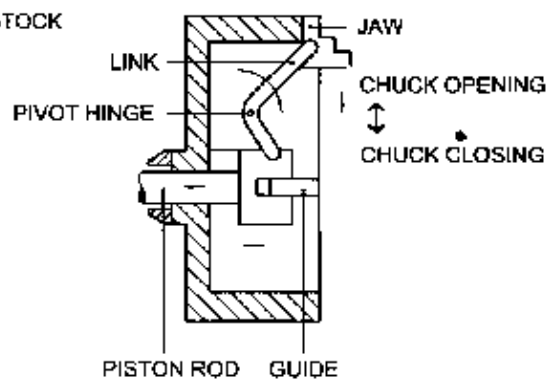
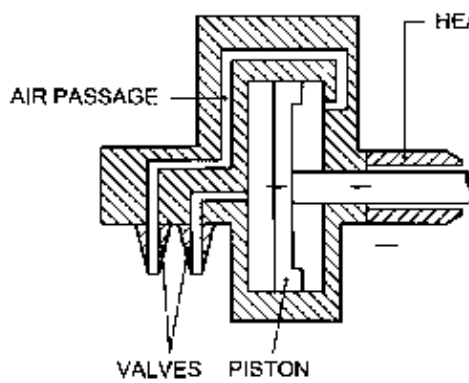

HYDRAULIC CHUCK
LATHE CHUCKS

Collet chucks

TR 01 13 01 02 93

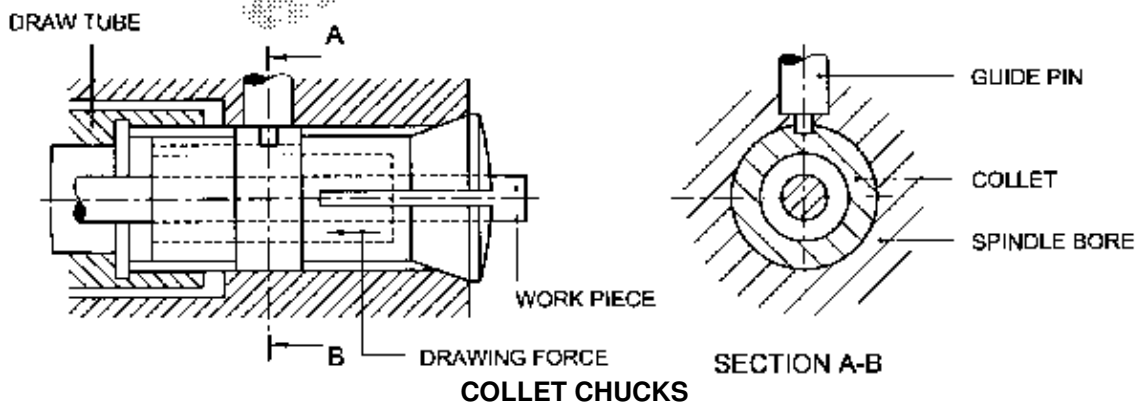
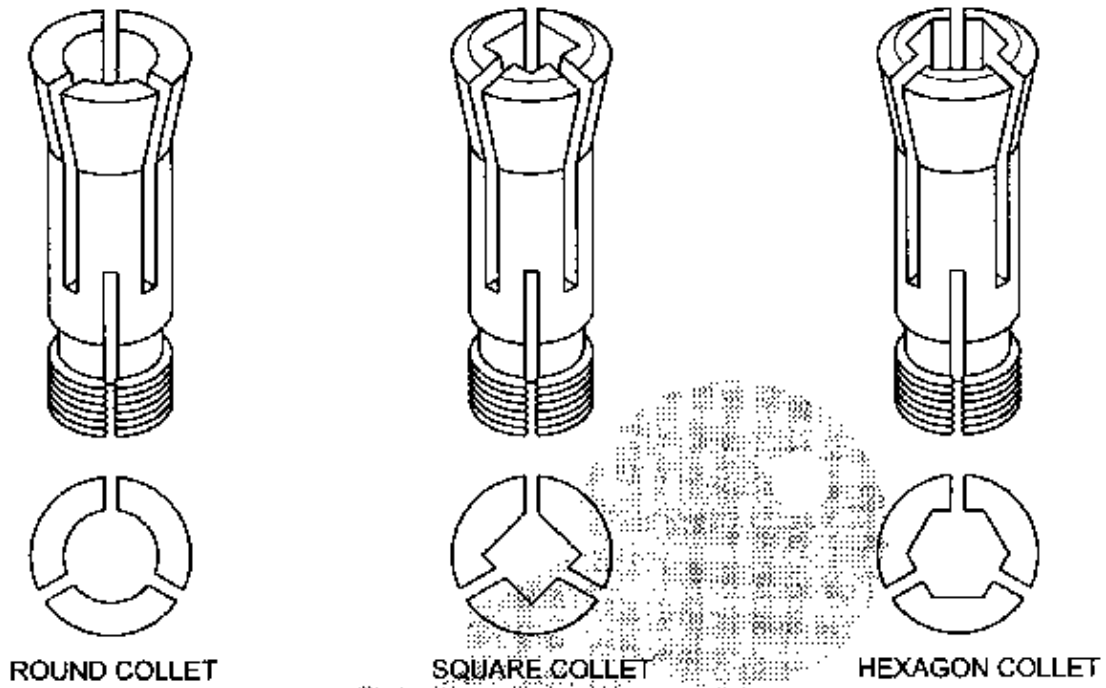

Lathe centres and their application

TR 01 13 02 01 93

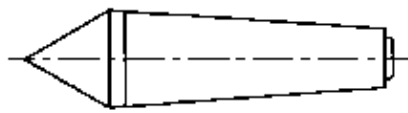

ORDINARY CENTRE

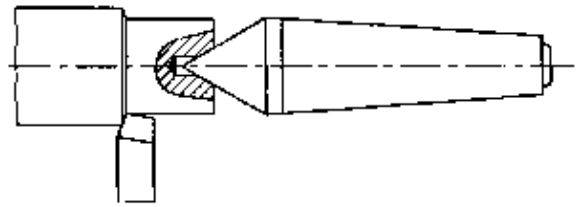

APPLICATION OF ORDINARY CENTRE

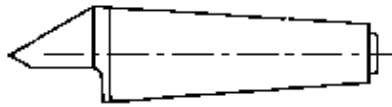

HALF CENTRE

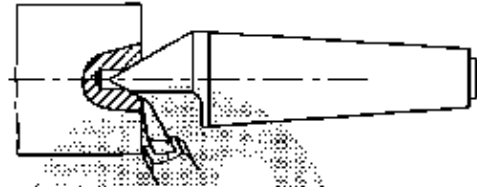

APPLICATION OF HALF CENTRE



BALL CENTRE

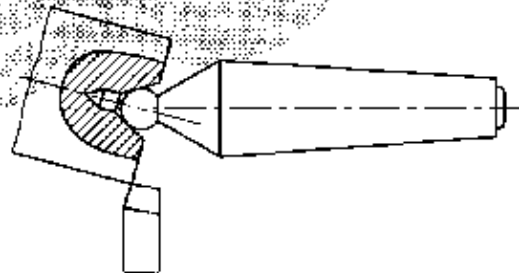

APPLICATION OF BALL CENTRE

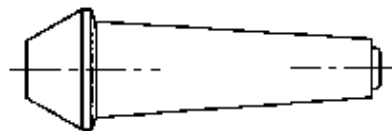

PIPE CENTRE

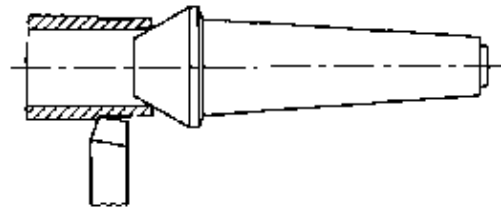

APPLICATION OF PIPE CENTRE

LATHE CENTRES AND THEIR APPLICATION

Lathe centres and their application

TR 01 13 02 02 93

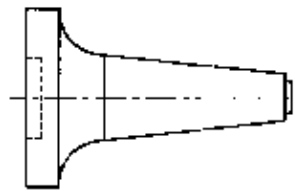

PAD CENTRE

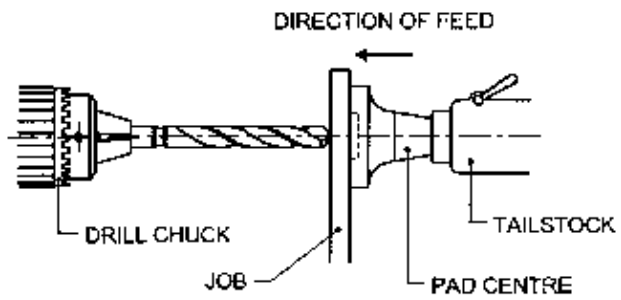

APPLICATION OF PAD CENTRE

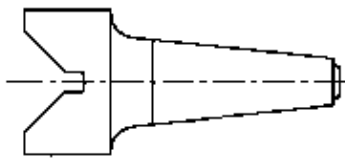

CROACH OR SWIVEL V CENTRE

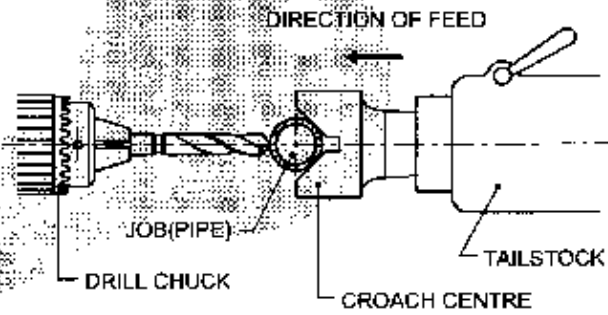

APPLICATION OF CROACH CENTRE

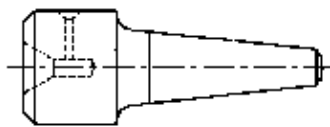

FEMALE CENTRE

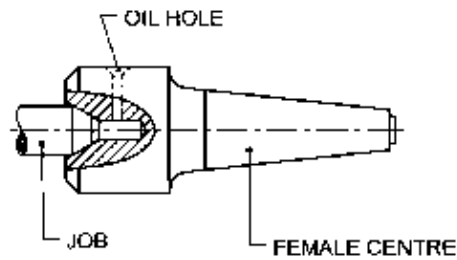

APPLICATION OF FEMALE CENTRE

LATHE CENTRES AND THEIR APPLICATION

Different methods of taper turning (Form tool and compound rest)

TR 01 15 03 01 93

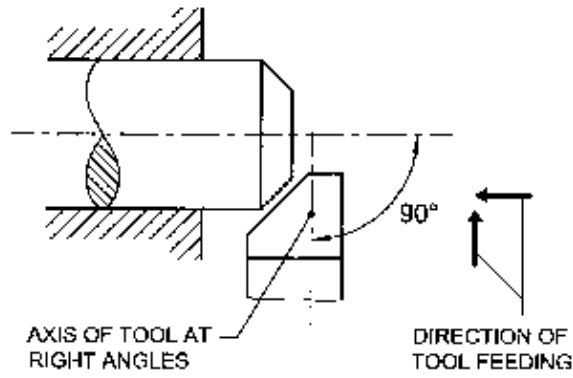

AXIS OF TOOL AT
RIGHT ANGLES

DIRECTION OF
TOOL FEEDING

FORM TOOL METHOD

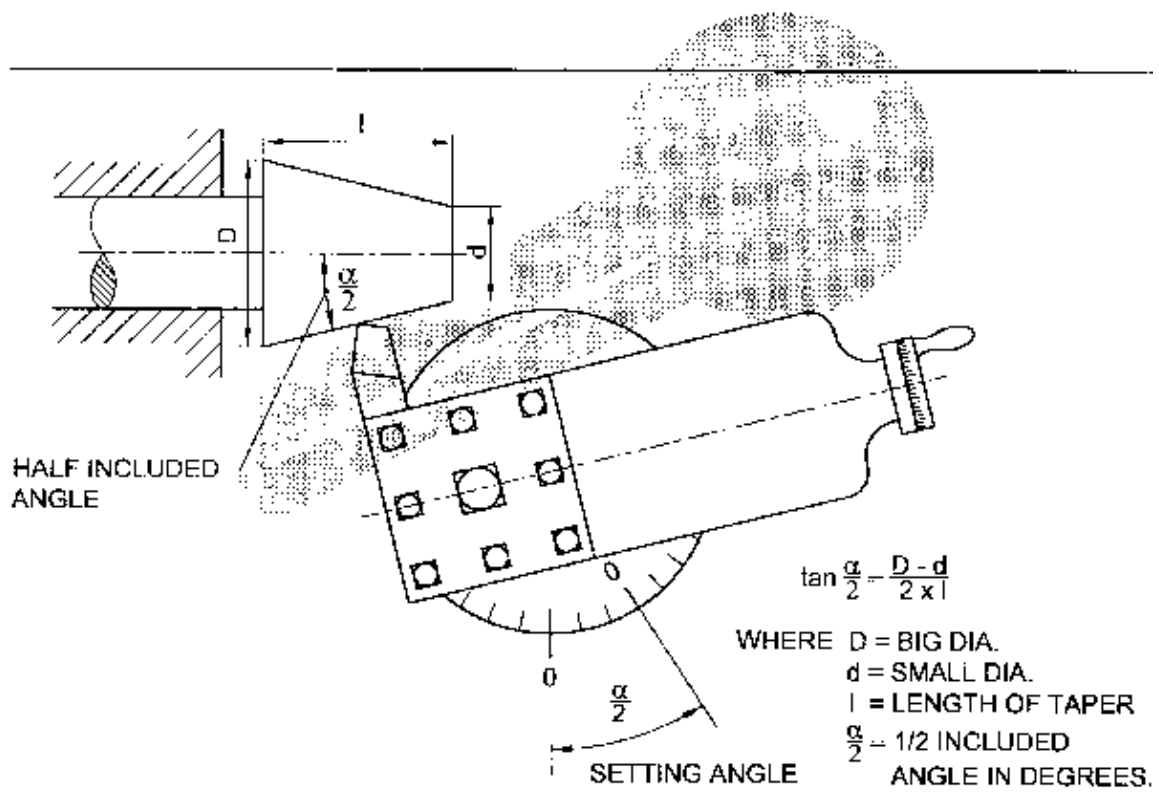

HALF INCLUDED
ANGLE

$$\tan \frac{\alpha}{2} = \frac{D-d}{2 \times l}$$

WHERE D = BIG DIA.
d = SMALL DIA.
l = LENGTH OF TAPER
 $\frac{\alpha}{2}$ = 1/2 INCLUDED
ANGLE IN DEGREES.

SETTING ANGLE

COMPOUND SLIDE METHOD
DIFFERENT METHODS OF TAPER TURNING (FORM TOOL AND COMPOUND REST)

Different methods of taper turning (Tails tock set over and taper turning attachment)

TR 01 15 03 02 93

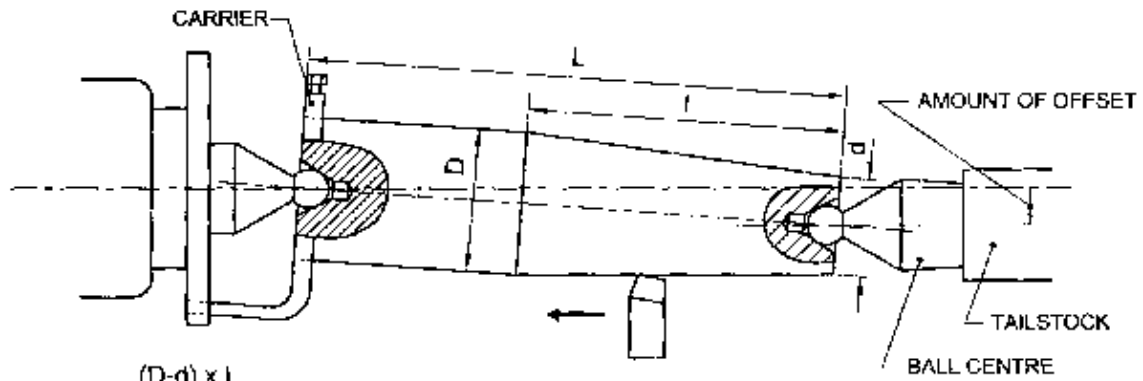

$$\text{OFFSET} = \frac{(D-d) \times L}{2 \times l}$$

Where D = Big dia. of taper
 d = Small dia. of taper
 l = Length of taper
 L = Total length of job

TAILSTOCK OFFSET METHOD

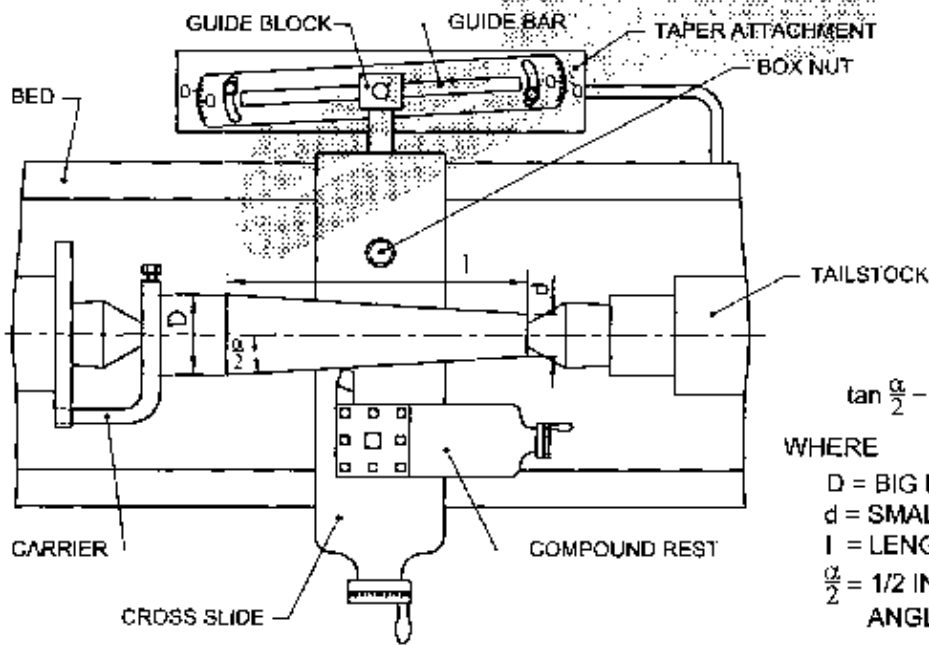

$$\tan \frac{\alpha}{2} = \frac{D-d}{2 \times l}$$

WHERE
 D = BIG DIA.
 d = SMALL DIA.
 l = LENGTH OF TAPER
 $\frac{\alpha}{2}$ = 1/2 INCLUDED
 ANGLE IN DEGREES.

TAPER TURNING ATTACHMENT METHOD

DIFFERENT METHODS OF TAPER TURNING (TAILS TOCK SET OVER AND TAPER TURNING ATTACHMENT)

Alignment of lathe centres

TR 01 15 03 03 93

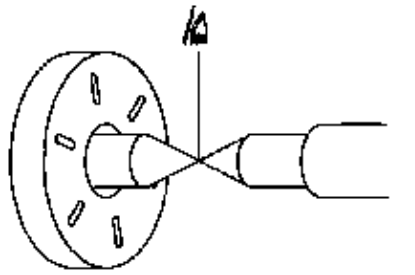

VISUAL ALIGNMENT OF CENTRES

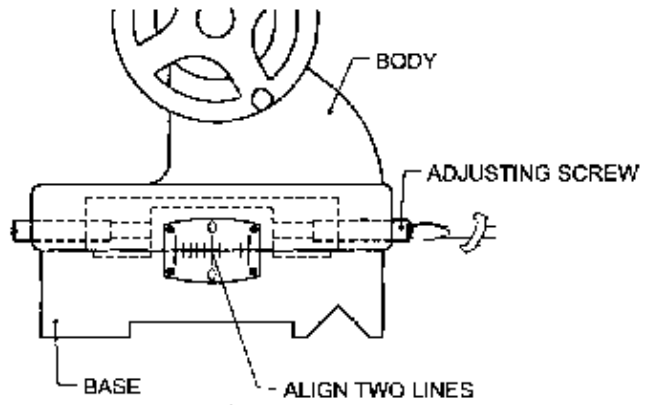

ALIGNMENT OF CENTRES USING GRADUATIONS ON BACK OF TAILSTOCK

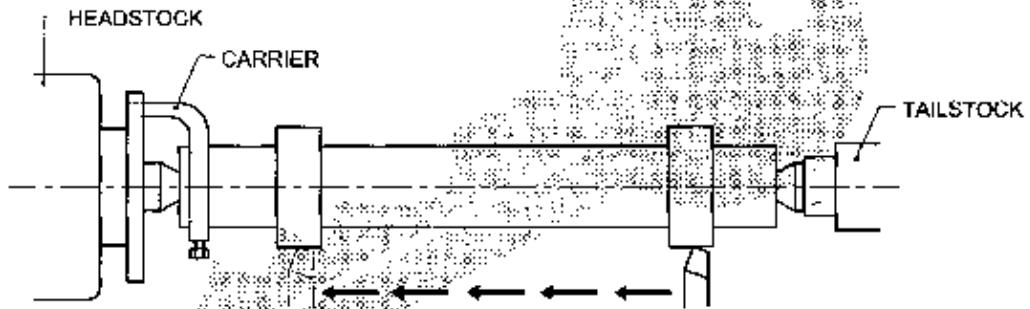

ALIGNMENT OF LATHE CENTRES BY TRAIL CUT METHOD

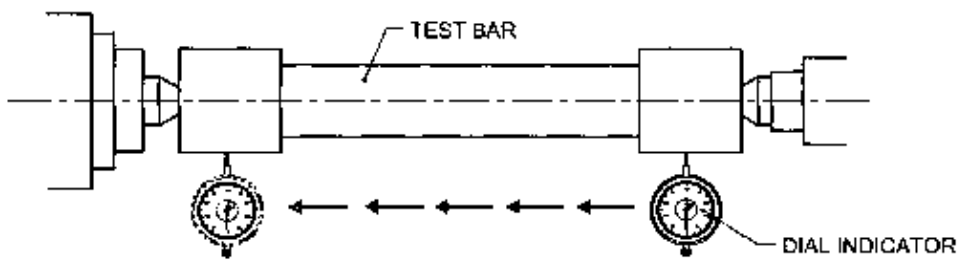

ALIGNING CENTRES WITH A TEST BAR AND DIAL INDICATOR
ALIGNMENT OF LATHE CENTRES

Turner 2nd Year – Transparencies

Table of Contents

Turner 2nd Year – Transparencies	1
<u>MEASUREMENT OF TAPER ANGLE USING SINEBAR</u>	1
<u>TAPER CALCULATION USING SINEBAR</u>	2
<u>TURRET LATHE (PARTS AND FUNCTION)</u>	3
<u>TURRET AND CAPSTAN LATHE (COMPARISON)</u>	4
<u>TURRET LATHE TOOL SETUP (EXTERNAL TURNING)</u>	5
<u>TURRET LATHE (EXTERNAL TURNING SEQUENCE)</u>	6
<u>SELF OPENING DIE-HEAD (WORKING PRINCIPLE)</u>	7
<u>BAR FEEDING MECHANISM (FUNCTION)</u>	8
<u>TURRET LATHE TOOL SETUP (INTERNAL TURNING)</u>	9
<u>TURRET LATHE (INTERNAL TURNING SEQUENCE)</u>	11
<u>AIR-OPERATED CHUCK (WORKING PRINCIPLE)</u>	12
<u>COLLET – DRAW-IN-TYPE (WORKING PRINCIPLE)</u>	13
<u>COLLET – PUSH OUT TYPE (WORKING PRINCIPLE)</u>	14
<u>COLLET – DEAD LENGTH TYPE (WORKING PRINCIPLE)</u>	15
<u>COPY TURNING ATTACHMENT (WORKING PRINCIPLE)</u>	15
<u>LEADING AND FOLLOWING ANGLES (SQUARE THREADING TOOL)</u>	16
<u>LEADING AND FOLLOWING ANGLES (ASSIGNMENT)</u>	17
<u>TAPER TURNING ATTACHMENT – YOKE TYPE (PRINCIPLE)</u>	18
<u>TAPER TURNING ATTACHMENT – TELESCOPIC TYPE</u>	19
<u>DOUBLE START THREAD (CATCH PLATE METHOD)</u>	20
<u>DOUBLE START THREAD (DIVIDING THE GEAR METHOD)</u>	21
<u>DOUBLE START THREAD (GRADUATED COLLAR METHOD)</u>	22
<u>THREAD CUTTING BY HALF ANGLE METHOD (PRINCIPLE)</u>	23

Turner 2nd Year – Transparencies



CENTRAL INSTRUCTIONAL
MEDIA INSTITUTE, MADRAS



ANINDO – GERMAN PROJECT

Directorate General of Employment & Training, Ministry of Labour, Govt. of India

Developed by
CENTRAL INSTITUTIONAL MEDIA INSTITUTE
in collaboration with DEUTSCHE GESELLSCHAFT FÜR TECHNISCHE ZUSAMMENARBEIT (GTZ)
Germany

P.O. Box 3142, 76, GST Road, Guindy, Madras – 600 032. Phone: 234 5256, 234 5257, Fax: (0091-44) 234 2791

MEASUREMENT OF TAPER ANGLE USING SINEBAR

TR 01 02 10 01 95

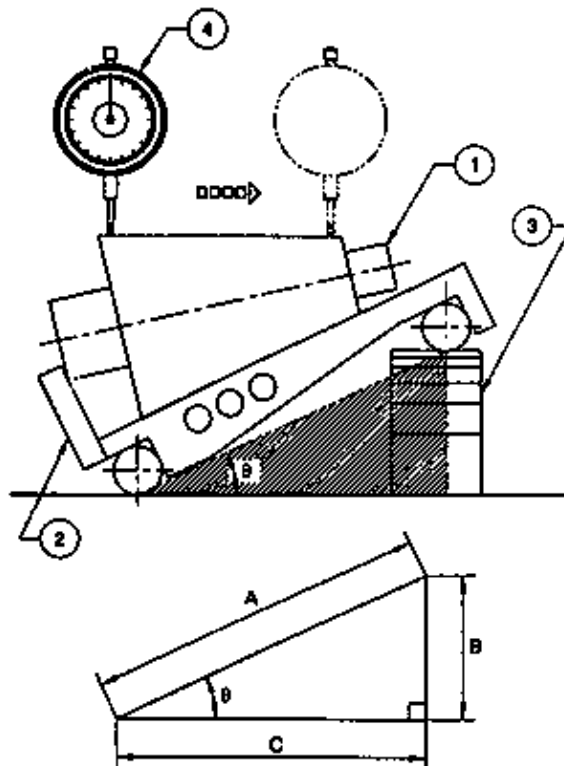

To calculate the angle of taper formed on a round rod, the job (1) is placed on sine bar (2). One end of the sine bar (i.e. smaller dia. end on job) is lifted up and slip gauges (3) are placed in between sine bar roller and the surface plate. The top surface of the taper portion should be brought to perfect horizontal line by placing additional slip gauges, and testing with dial test indicator (4). A right angled triangle is formed, with the slip gauge height as opposite side (B) and the length of sine bar as hypotenuse (A). By applying the trigonometrical ratio formula,

$\text{sine } \theta = \frac{\text{Opposite side}}{\text{Hypotenuse}}$, we get sine ? value in degrees i.e. the included angle of the tapered job.

TAPER CALCULATION USING SINEBAR

TR 01 02 10 02 95

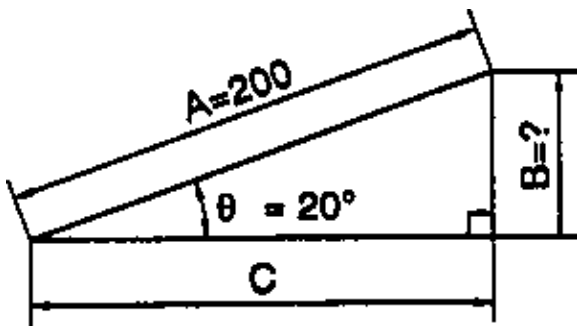

1. $\text{Sine } 20^\circ = \frac{B}{A} = \frac{B}{200}$

Therefore B = 68.404.

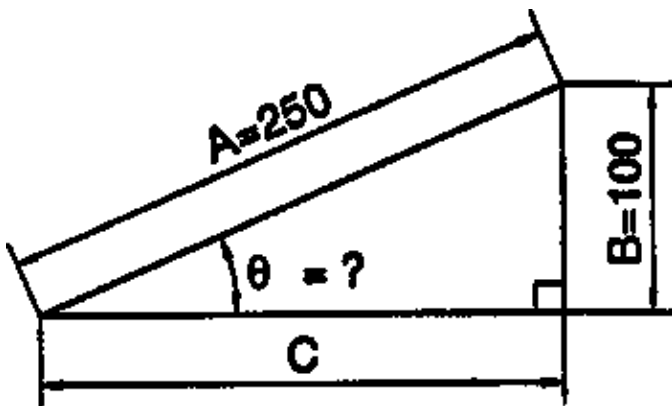

2. $\text{Sine } \theta = \frac{B}{A} = \frac{100}{250}$

Therefore ? = 23° 34' 41"

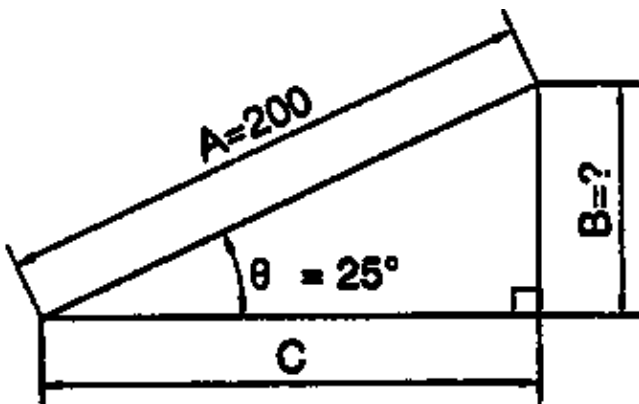

3. $\text{Sine } 25^\circ = \frac{B}{A} = \frac{B}{200}$

Therefore B = 84.524

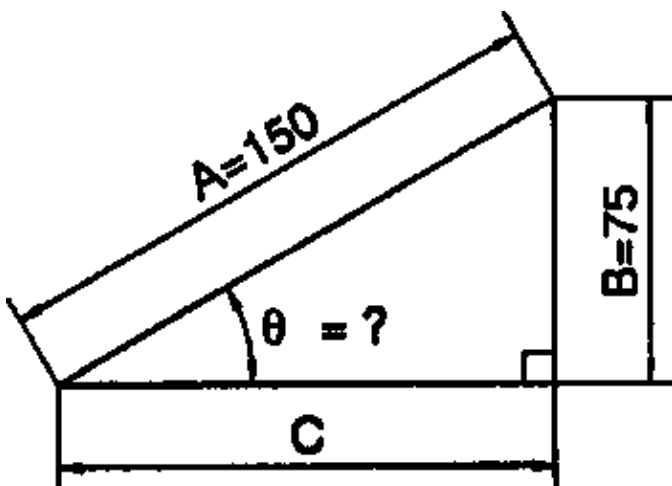

4. $\text{Sine } \theta = \frac{B}{A} = \frac{75}{150}$

Therefore ? = 30°

TURRET LATHE (PARTS AND FUNCTION)

TR 01 12 02 01 95

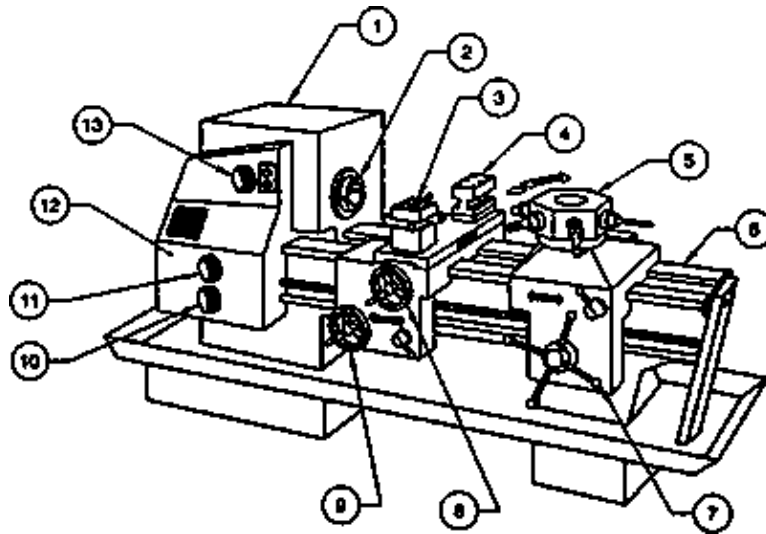

- | | |
|--|---|
| 1. Head stock | Speed changing gears and spindle are housed in the head stock. |
| 2. Spindle | Collets and chucks are mounted on the spindle for work holding. |
| 3. Square tool post | Four different tools can be set at a time. |
| 4. Rear tool post | Parting-off tool can be set in this tool post in inverted position. |
| 5. Turret head | The turret head has six faces and can hold six different tools. |
| 6. Main bed | Carriage and the turret head slide, over the bed. |
| 7. Handwheel for the longitudinal motion of turret | Moves the turret head along the bed. |
| 8. Cross slide hand wheel | Moves the cross slide to give depth of cut. |
| 9. Carriage hand wheel | Moves the carriage along the bed. |
| 10. Feed drive for turret | Knob for turret automatic feed. |
| 11. Feed drive for cross slide | Knob for cross-slide automatic feed. |

12. Feed gear box

This will have a number of gears and provide different feed rates for longitudinal and crosswise movements.

13. Spindle speed

Different spindle speeds can be obtained by rotating the selector to different positions.

TURRET AND CAPSTAN LATHE (COMPARISON)

TR 01 12 02 02 95

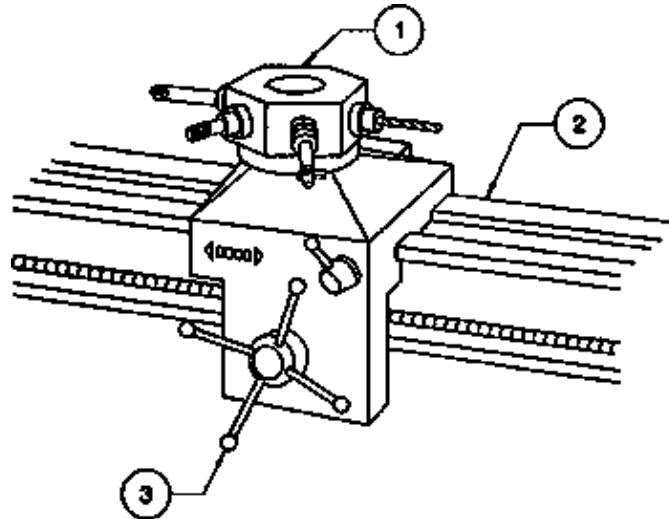

TURRET LATHE

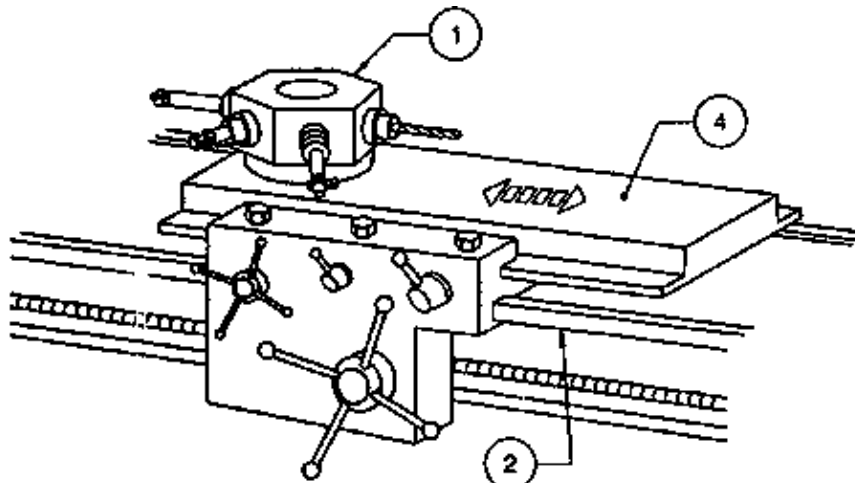

CAPSTAN LATHE

1. Both the lathes are used for mass production work.
2. Turret lathe is a heavy duty machine and Capstan lathe is a light duty machine.
3. In a turret lathe the turret head (1) is directly mounted on the main bed (2).
4. In a capstan lathe the turret head (1) is mounted on an additional slide (4).
5. In a turret lathe the turret head (1) can be moved over the main bed (2) from one end to the other end.
6. In a capstan lathe, the turret head (1) can be moved over the additional slide (4) within its limitations.

TURRET LATHE TOOL SETUP (EXTERNAL TURNING)

TR 01 12 02 03 95

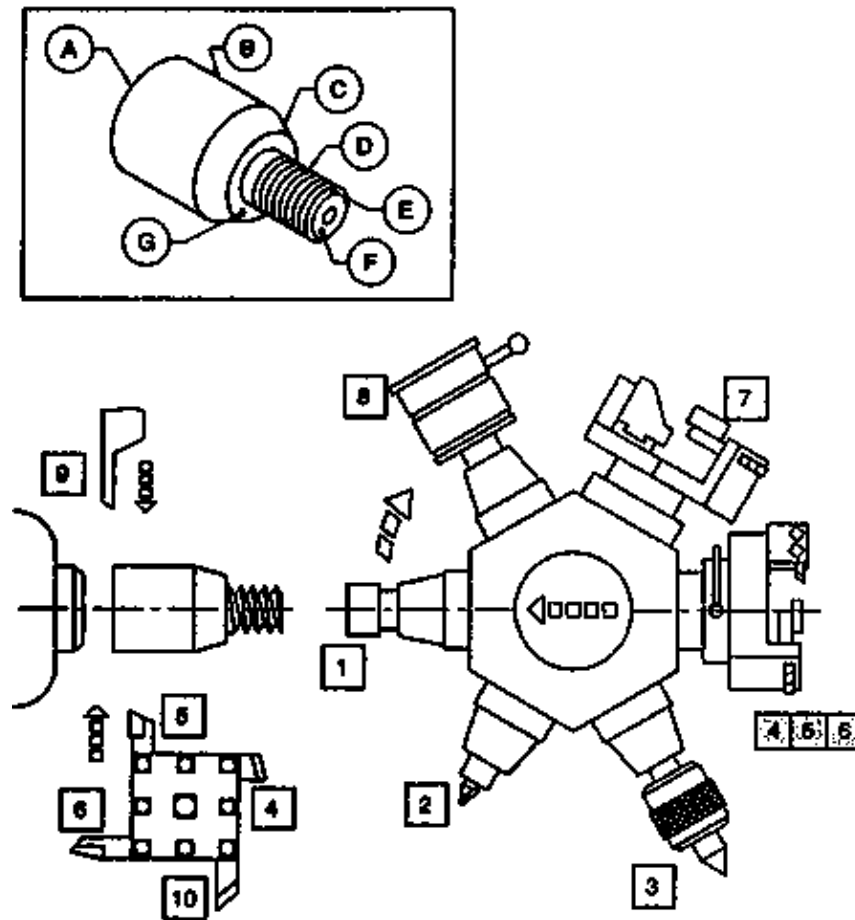

TOOLING SEQUENCE

1. Bar stop
2. Step turning
3. Centre drilling
4. Taper (Form turning)
5. Shoulder facing

Note: To be discussed along with the

Transparencies
No. TR 01 12 02 04 95
TR 01 12 02 05 95

Work centre is supported during machining steps

4 5 6

OPERATIONS ON THE COMPONENT

- A Parting-off
- B O.D. Turning
- C Form turning
- D Thread cutting
- E Chamfering
- F Facing

TURRET LATHE (EXTERNAL TURNING SEQUENCE)

TR 01 12 02 04 95

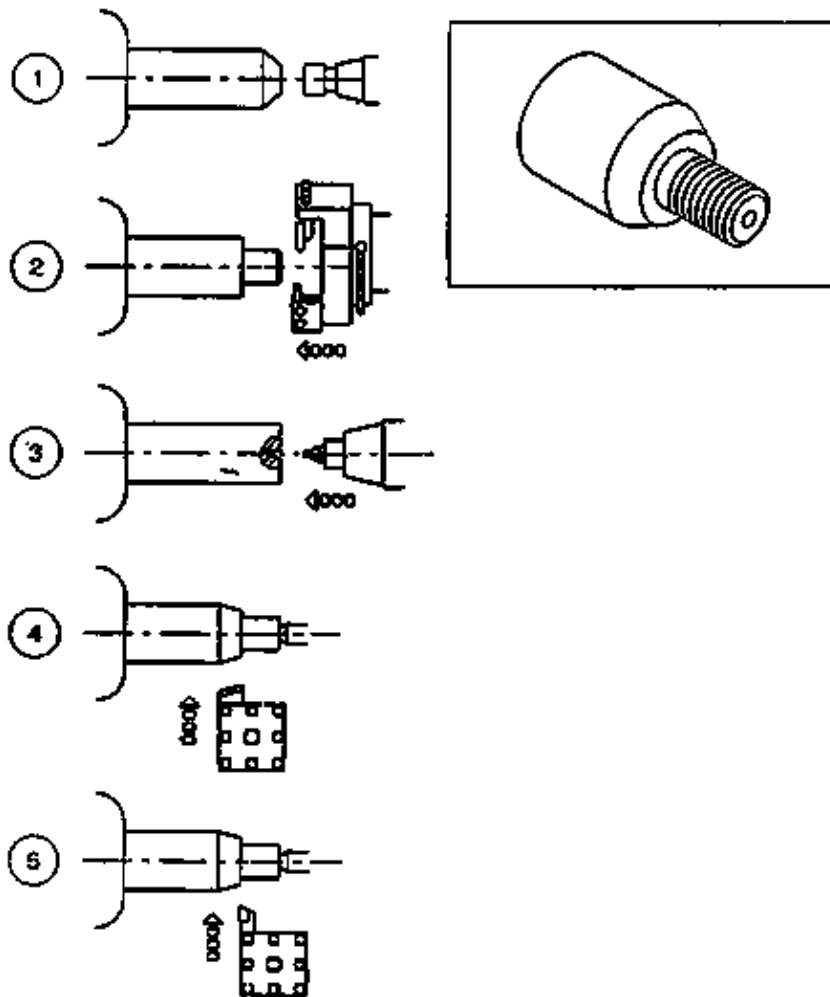

1. Bar stop
2. Step turning
3. Centre drilling
4. Centre support and forming taper
5. Centre support and shoulder facing

TR 01 12 02 05 95

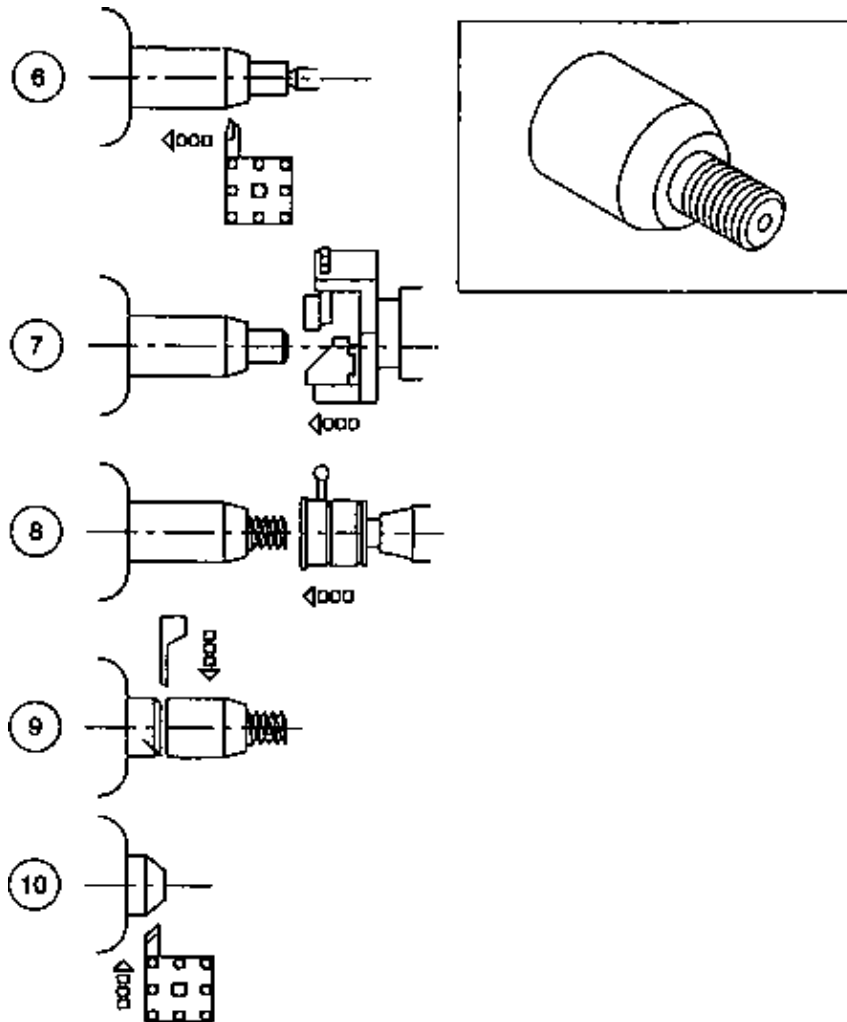

- 6. Centre support and O.D. turning
- 7. Chamfering
- 8. Threading
- 9. Parting off
- 10. Forming end

SELF OPENING DIE-HEAD (WORKING PRINCIPLE)

TR 01 12 02 06 95

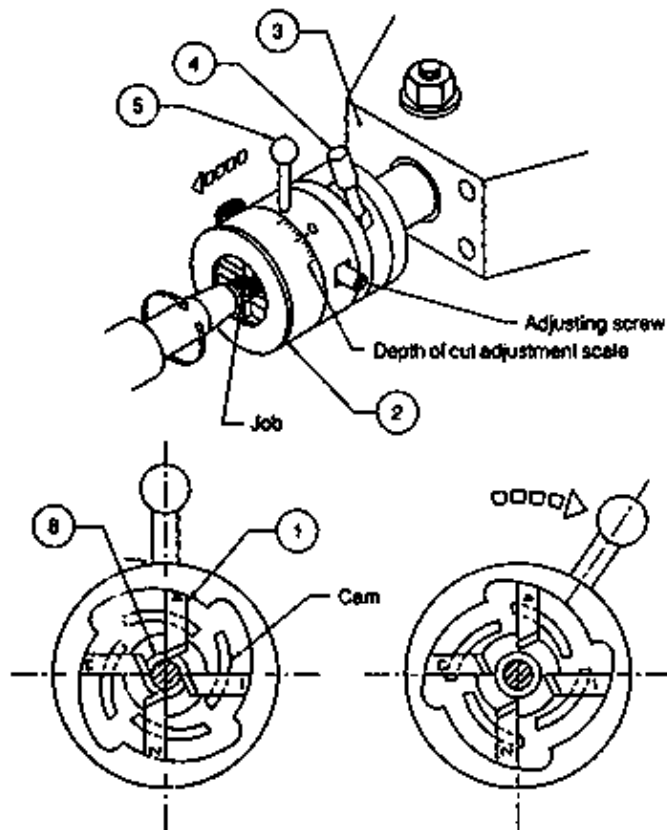

After setting the required size of chasers (1) in the die head (2), it is initially fed to the work by the operator. Then it feeds itself along the work and follows with the turret (3). The turret stopper is set slightly short of the thread length.

When the turret movement is stopped by its stopper, the die head (2) continues to move forward under self feeding action.

When there is no further movement for the die head, an inside trip triggers off, the detent pin (4) goes into action, the closing handle (5) falls to the side and the die opens. The die head is taken out without stopping the machine.

Note: The chasers are numbered as 1,2,3 and 4.

BAR FEEDING MECHANISM (FUNCTION)

TR 01 12 02 07 95

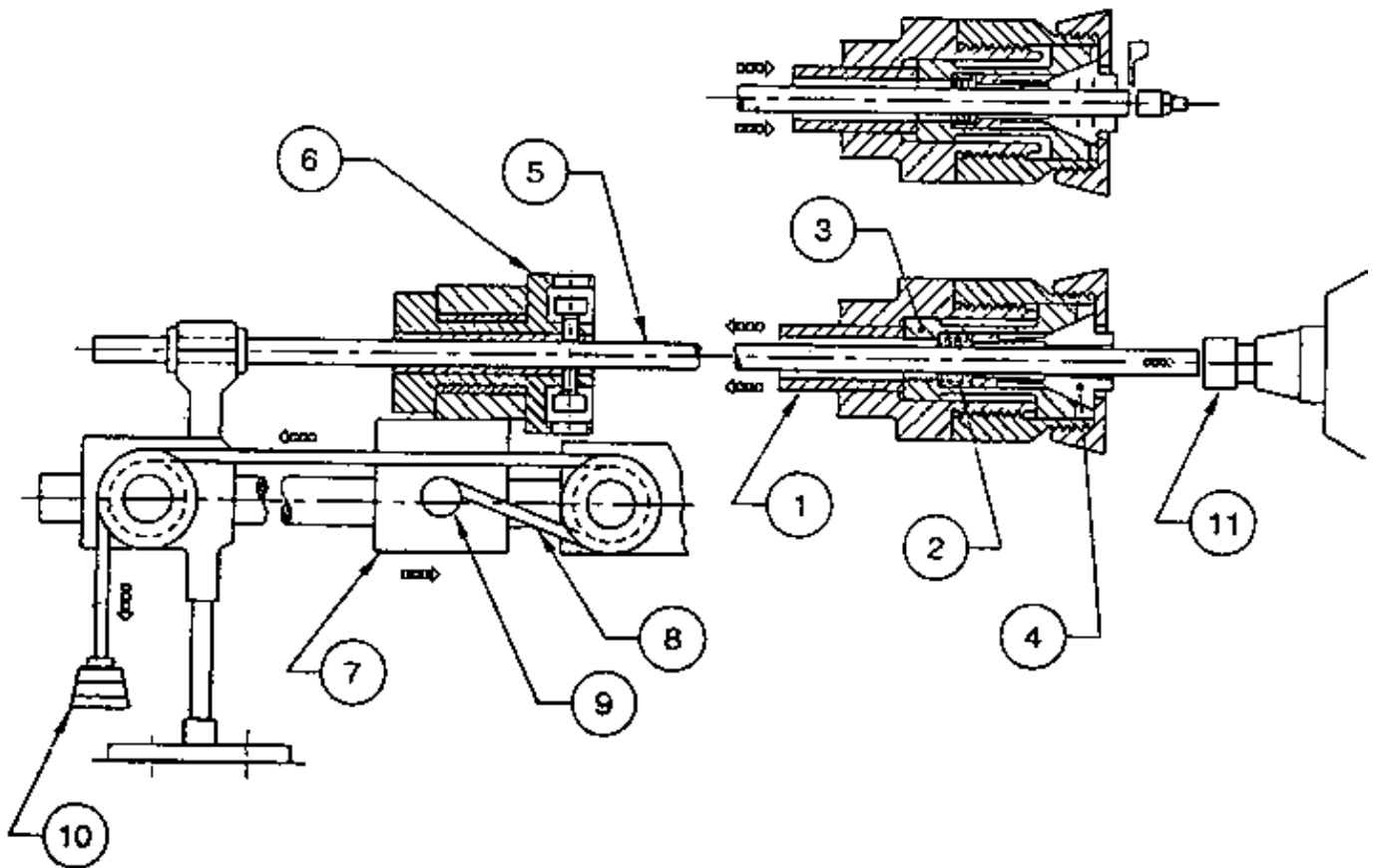

When all operations are completed, the job is parted-off with a parting-off tool. Now, the bar is to be fed for the next component. The push tube (1) is pulled back by operating a lever. The spring (2) pushes back the sliding sleeve (3) resulting in the opening of the collet (4).

The bar (5) is fitted to bar chuck (6) which is resting on sliding bracket (7). One end of the rope (8) is connected to the pin (9) on the sliding bracket and the other end supports the weight (10). When the collet chuck is released, the weight moves in a down-ward direction and the sliding bracket (7) moves forward along with bar chuck and bar, until the bar touches the bar stop (11).

TURRET LATHE TOOL SETUP (INTERNAL TURNING)

TR 01 12 02 08 95

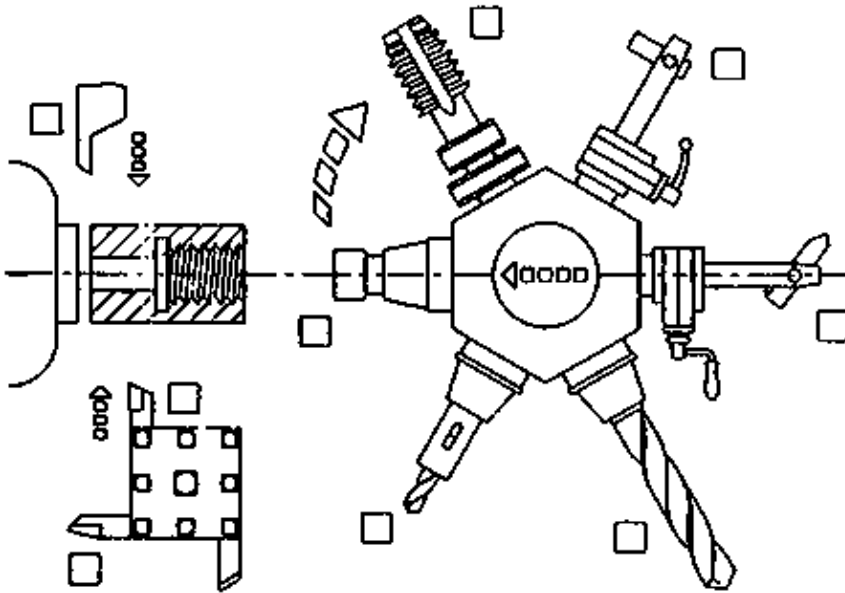
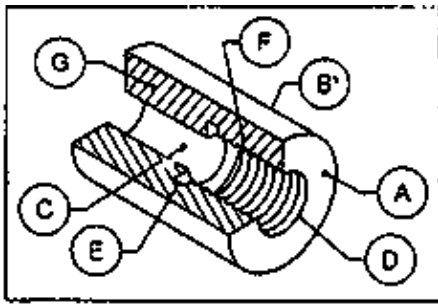

TOOLING SEQUENCE

- | | |
|--------------------|-------------------|
| 1 Facing | 5 Counter boring |
| 2 O.D. Turning | 6 Recessing |
| 3 Spotting (drill) | 7 Threading (Tap) |
| 4 Drilling | 8 Parting-off |

Note: To be discussed along with the

Transparencies

No. TR 01 12 02 09 95

TR 01 12 02 10 95

OPERATIONS ON THE COMPONENT

- A Facing
- B O.D. Turning
- C Drilling
- D Boring
- E Recessing
- F Threading
- G Parting-off

TURRET LATHE (INTERNAL TURNING SEQUENCE)

TR 01 12 02 09 95

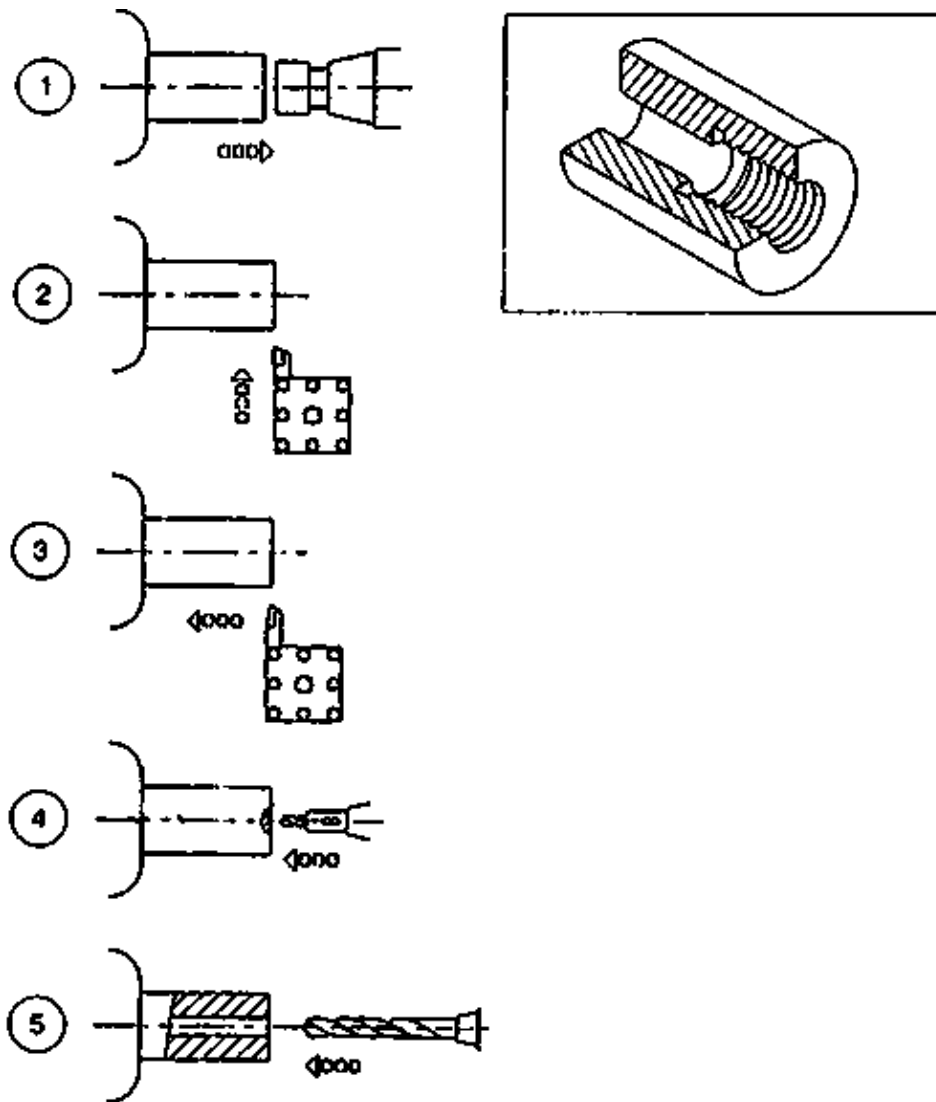

1. Bar stop
2. Facing
3. O.D. Turning
4. Start drill (spotting)
5. Drilling

TR 01 12 02 10 95

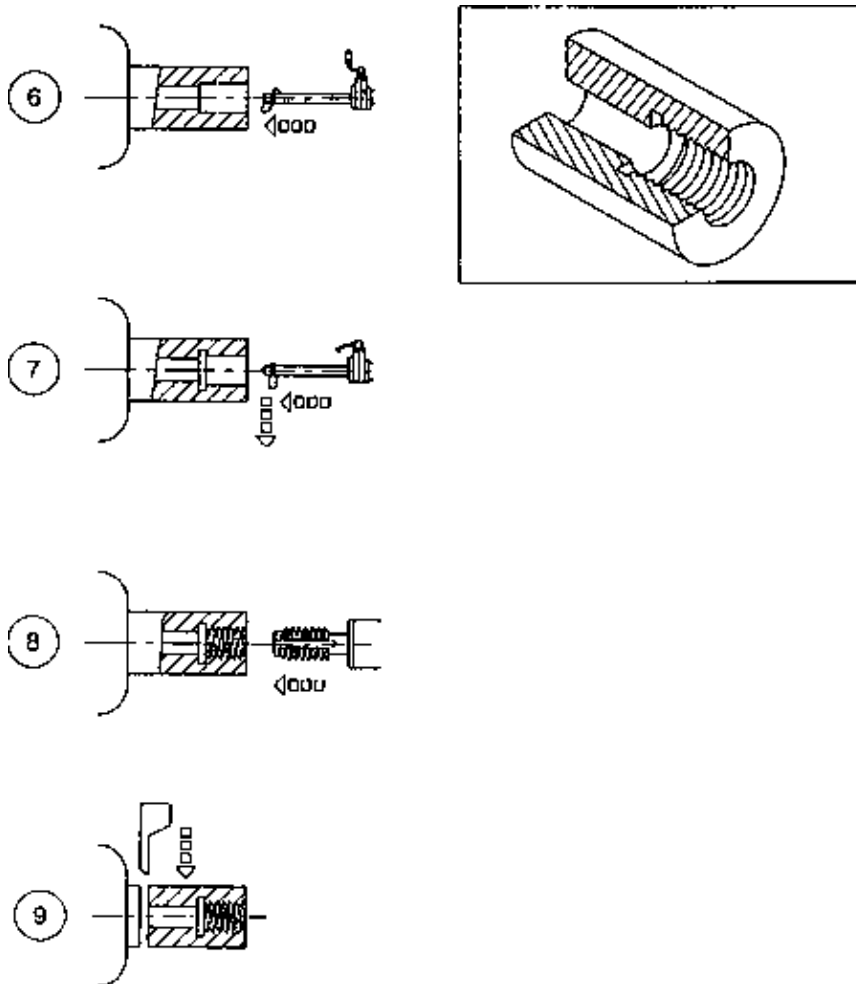

6. Counter boring
7. Recessing
8. Threading with tap
9. Parting-off

AIR-OPERATED CHUCK (WORKING PRINCIPLE)

TR 01 13 01 03 95

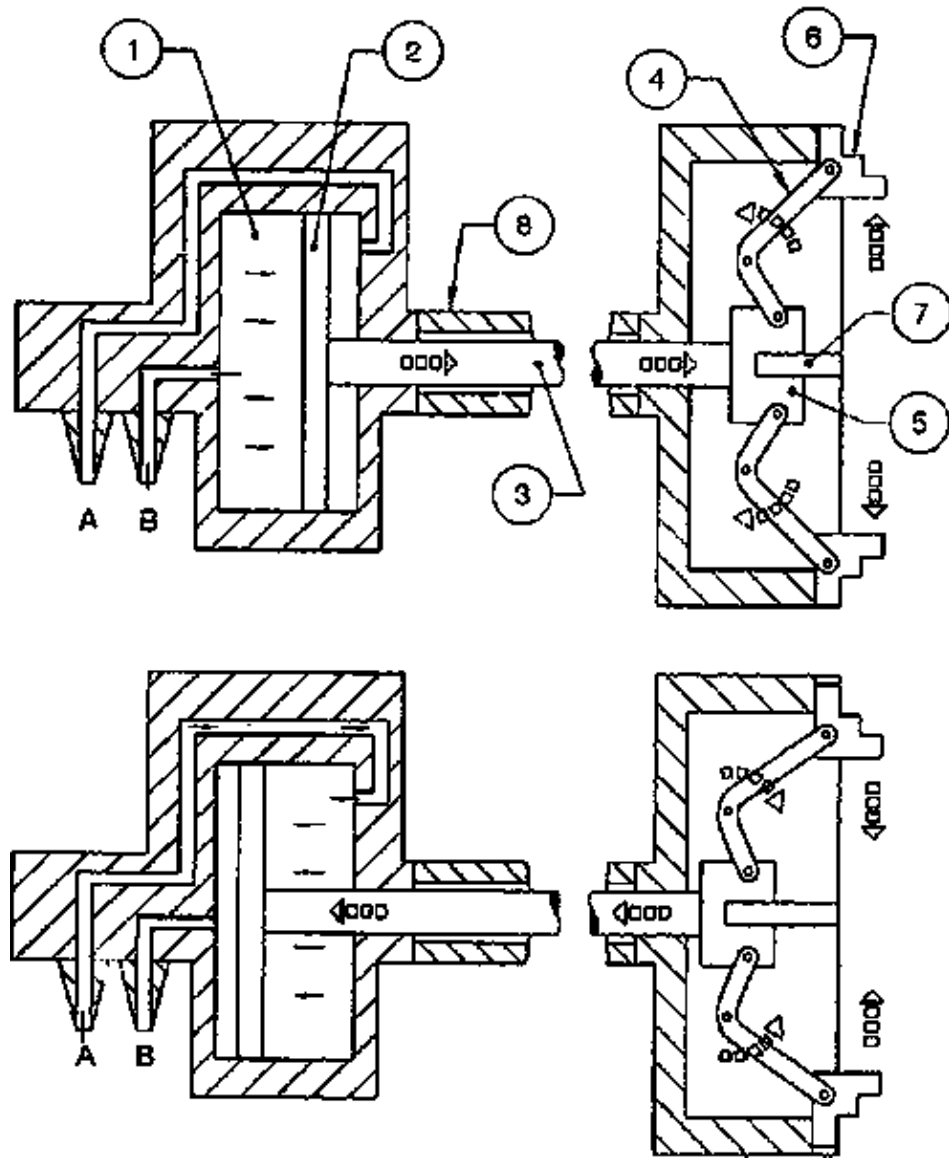

Air operated chuck is used in mass production work because of its fast and effective gripping capacity. The mechanism consists of an air cylinder mounted at the rear end of the head stock spindle and rotates with it. Pressure is transmitted to the cylinder by operating a valve with a lever. When the air pressure enters the cylinder (1) through the pipe B, the piston (2) moves forward along with the piston rod (3) attached. The links (4) keyed to the sliding unit (5) are moved and the jaws (6) get opened and the job held in the chuck is released.

When the air pressure enters the cylinder through the pipe A, the piston (2) moves backward. The links (4) are moved, the jaws (6) get closed and the job is gripped in the chuck.

COLLET – DRAW-IN-TYPE (WORKING PRINCIPLE)

TR 01 13 01 04 95

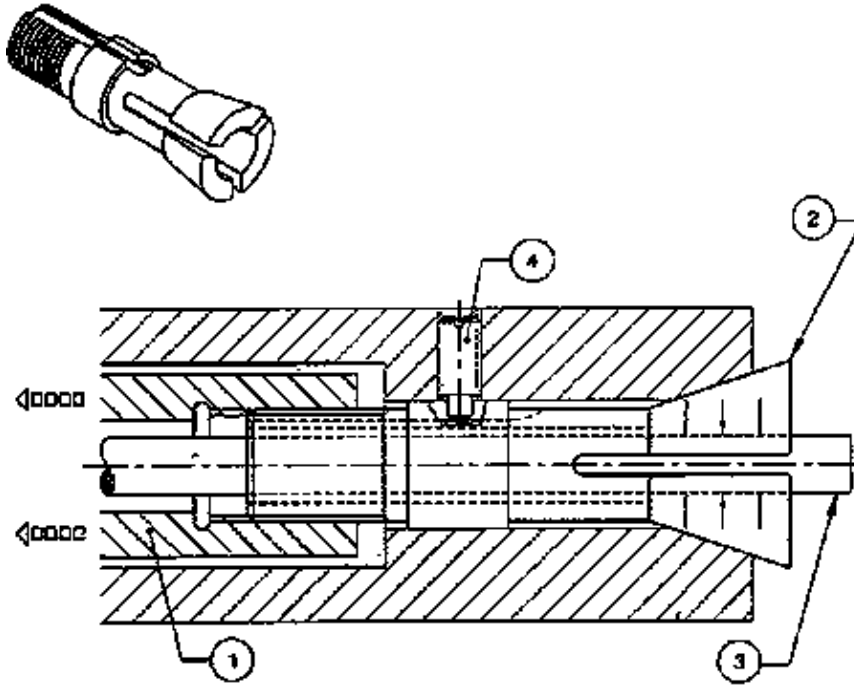

By rotating the draw tube (1) the collet (2) is pulled back as the draw tube and the collet have matching threads. Due to this the split end of the collet comes closer and grips the bar (3). The guide pin (4) guides the collet to move straight without rotation.

The machining length of the bar can not be set accurately, as the collet while closing, will draw the bar slightly inward, necessary allowance should be provided to overcome this.

COLLET – PUSH OUT TYPE (WORKING PRINCIPLE)

TR 01 13 01 05 95

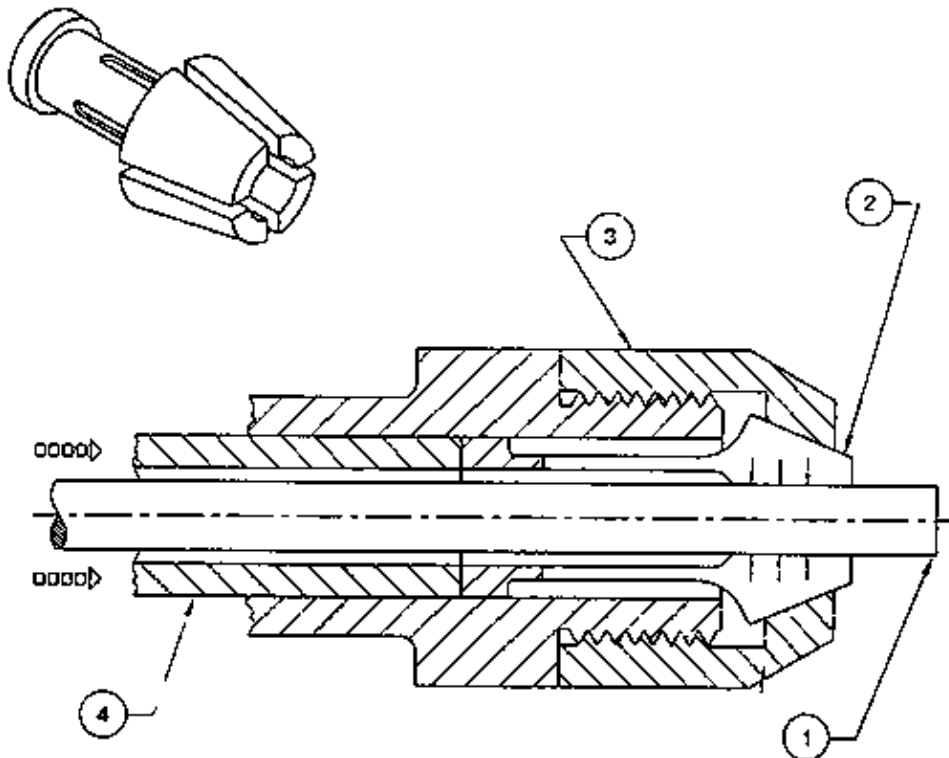

To grip the bar (1), the tapered portion of the collet (2) is pushed into the mating taper of the hood (3) with the help of push tube (4). During this process, there is a tendency for the bar (1) to be pushed slightly outward. If

the bar is fed against a bar stop fitted on the turret head, it will ensure accurate setting of the length for machining.

COLLET – DEAD LENGTH TYPE (WORKING PRINCIPLE)

TR 01 13 01 06 95

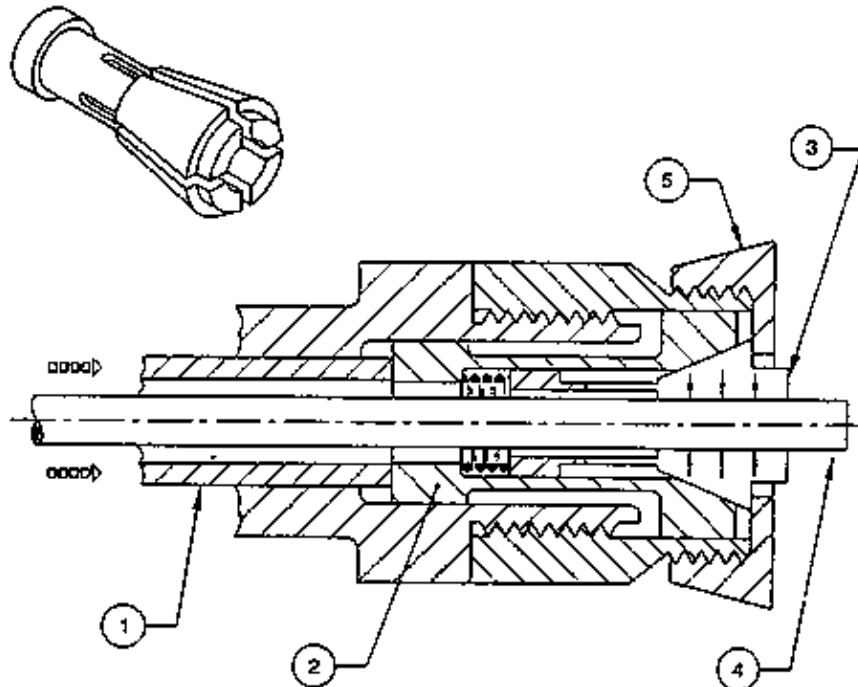

This collet can accurately position the bar to the required length. When the push tube (1) pushes the sliding sleeve (2) forward towards the taper portion of the collet (3), the split end comes closer and grips the bar (4). The shoulder stop of the hood (5) will not allow any end movement for the collet (3) as well as the bar (4).

COPY TURNING ATTACHMENT (WORKING PRINCIPLE)

TR 01 13 01 03 95

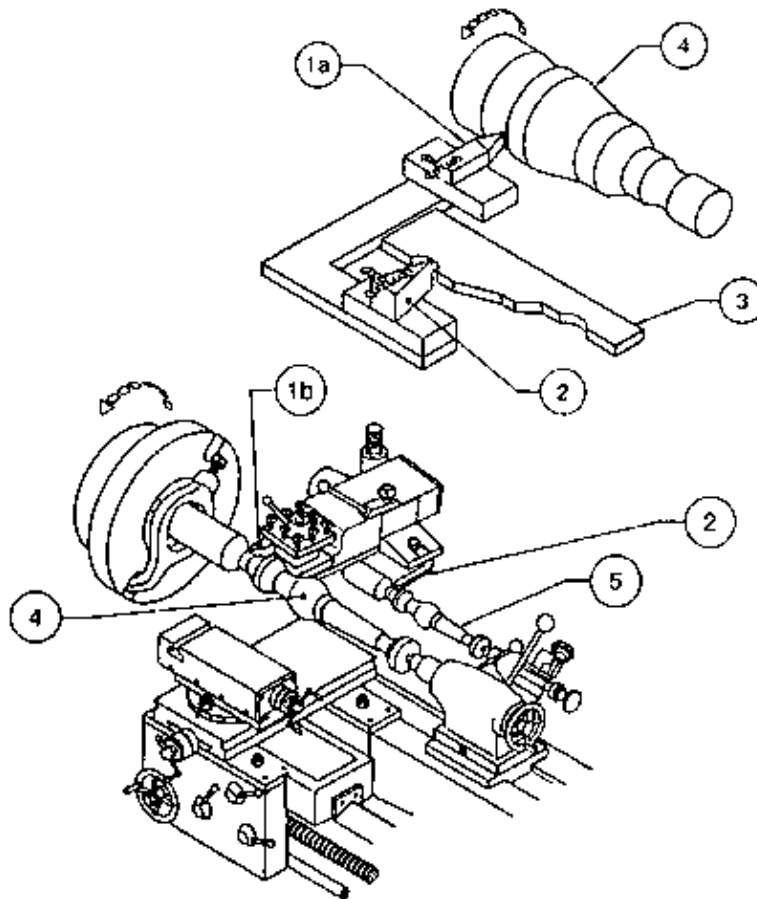

PRINCIPLE

The copying attachment is functioning with the help of hydraulic system. The cutting tool (1 a) and the stylus (2) are connected to an angle shaped piece which is linked to a hydraulic system. The movement of the stylus is guided by the profile of a template(3).

FUNCTION

On the lathe the job (4) is held between centres. A master piece (5) of the job to be produced is held separately parallel to the job axis. The cutting tool (1 b) is held up-side down in the rear tool post which is linked to a stylus (2).

When the automatic feed is engaged, the stylus (2) moves from tail stock to head stock with a forward pressure. The movement of the stylus (2) is guided by the profile of the master piece (5).

LEADING AND FOLLOWING ANGLES (SQUARE THREADING TOOL)

TR 01 14 02 01 95

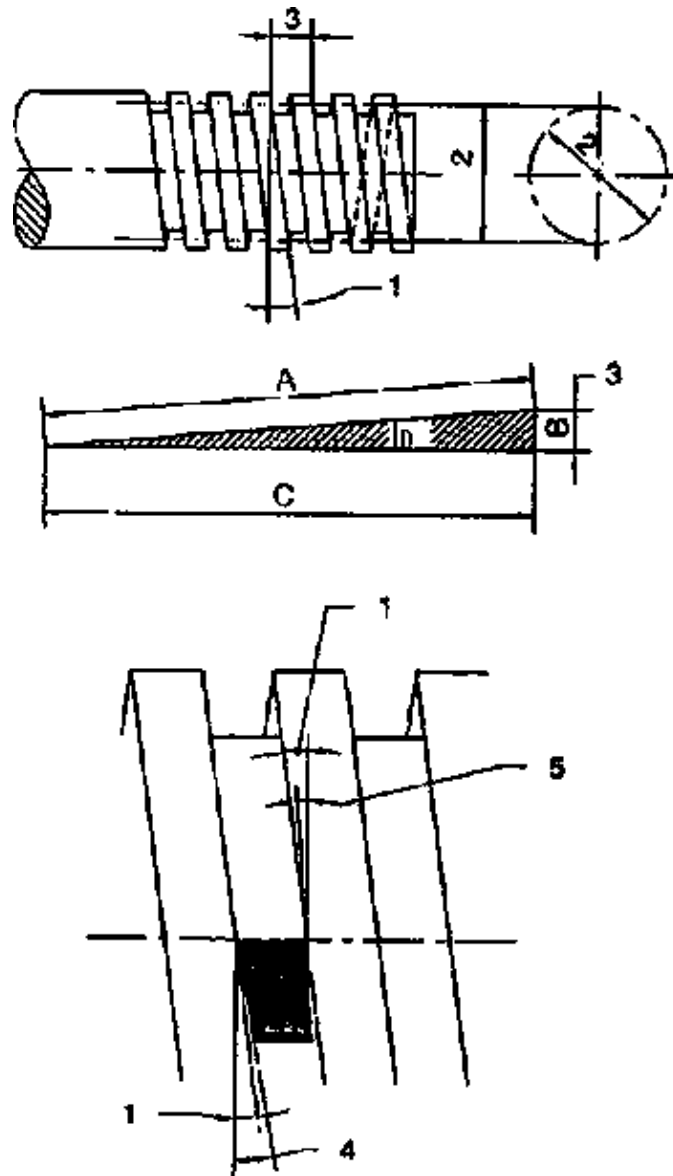

When a square tool which is similar to a parting-off tool is used for cutting a square thread, the bottom of the tool (side) will rub against the side of the thread. This is because, when a thread is cut, an inclined groove is formed on the circumference of the round rod. This inclined (side) portion will rub against the bottom of the tool. This inclination to the perpendicular line is called the helix angle of the thread.

To calculate the helix angle (1), a right angled triangle is formed with circumference of pitch diameter (2) as adjacent side and the lead of the thread (3) as opposite side for the triangle. By applying the formula,

$$\text{Tan}\theta = \frac{\text{Opposite side}}{\text{Adjacent side}}$$
, we get the helix angle of the square thread.

The leading angle (4) and the following angle (5) of the square threading tool can be arrived at as follows:-

Leading angle = Helix angle + 1° 30'

Following angle = Helix angle - 1° 30'

LEADING AND FOLLOWING ANGLES (ASSIGNMENT)

TR 01 14 02 02 95

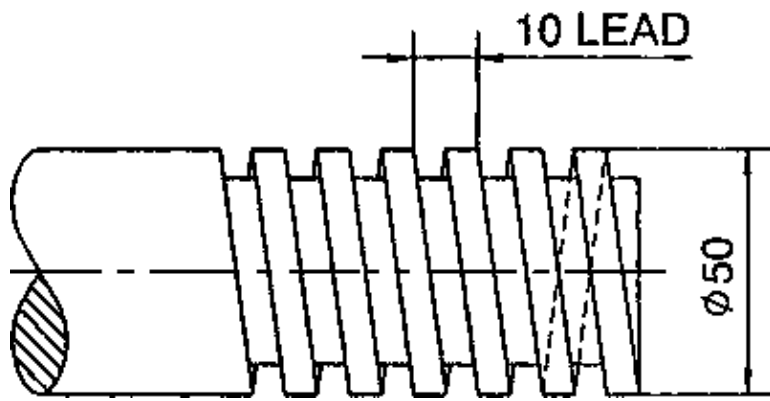

Helix angle = $4^{\circ}2'$
 Leading angle = $4^{\circ}2' + 1^{\circ}30' = 5^{\circ}32'$
 Following angle = $4^{\circ}2' - 1^{\circ}30' = 2^{\circ}32'$

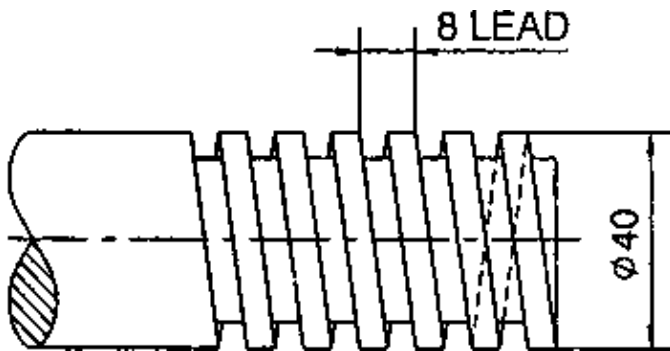

Helix angle = $4^{\circ}2'$
 Leading angle = $4^{\circ}2' + 1^{\circ}30' = 5^{\circ}32'$
 Following angle = $4^{\circ}2' - 1^{\circ}30' = 2^{\circ}32'$

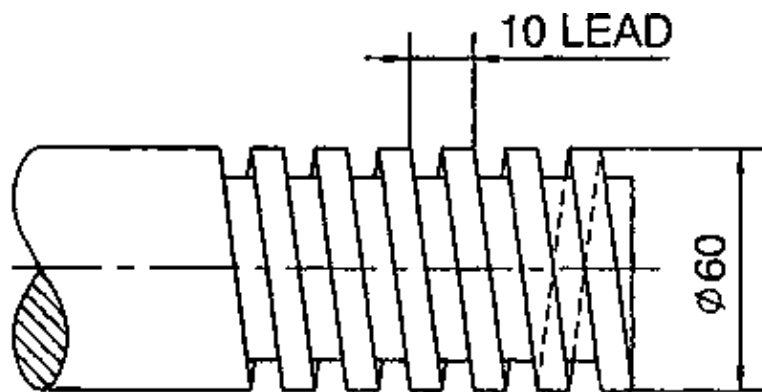

Helix angle = $3^{\circ}18'$
 Leading angle = $3^{\circ}18' + 1^{\circ}30' = 4^{\circ}48'$
 Following angle = $3^{\circ}18' - 1^{\circ}30' = 1^{\circ}48'$

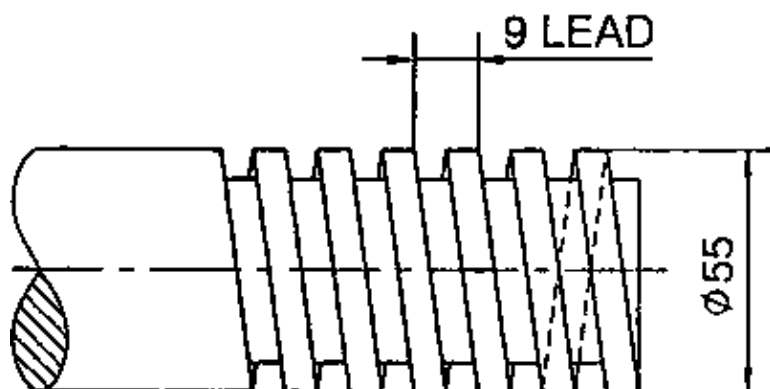

Helix angle = $3^{\circ}15'$
 Leading angle = $3^{\circ}15' + 1^{\circ}30' = 4^{\circ}45'$
 Following angle = $3^{\circ}15' - 1^{\circ}30' = 1^{\circ}45'$

TAPER TURNING ATTACHMENT – YOKE TYPE (PRINCIPLE)

TR 01 15 03 04 95

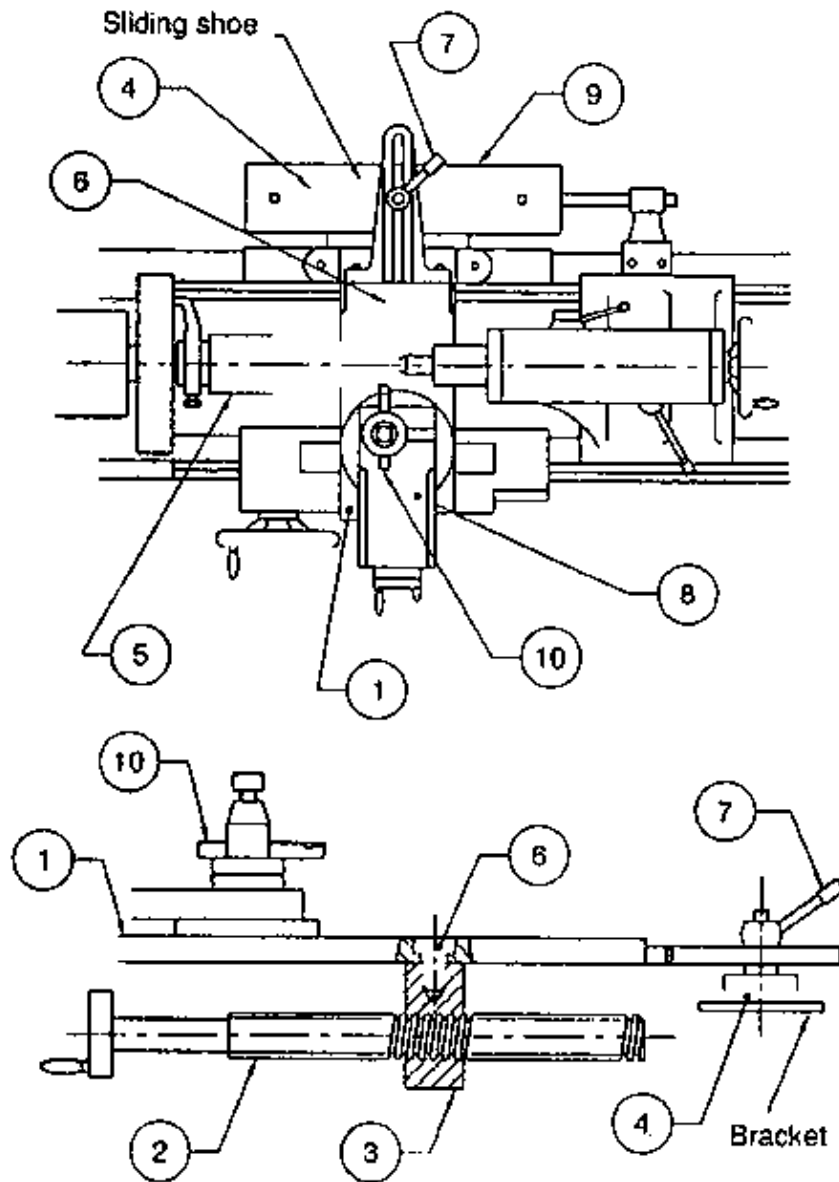

In the normal working condition the cross slide (1) is moved forward and backward with the rotation of a screw rod (2) which is linked to a box nut (3). The guide bar (4) is set to an angle equal to the angle of taper on job (5). The taper attachment is centrally located to cover the length of taper on job. The screw (6) is removed to de-link the box nut. The cross-slide is linked to the taper attachment by tightening the binding screw handle (7). When the machine is started with automatic feed on, the tool (10) will move in an inclined direction equal to the angle set on guide bar (4). The compound rest (8) is tilted perpendicular to the job axis to give depth of cut.

TAPER TURNING ATTACHMENT – TELESCOPIC TYPE

TR 01 15 03 05 95

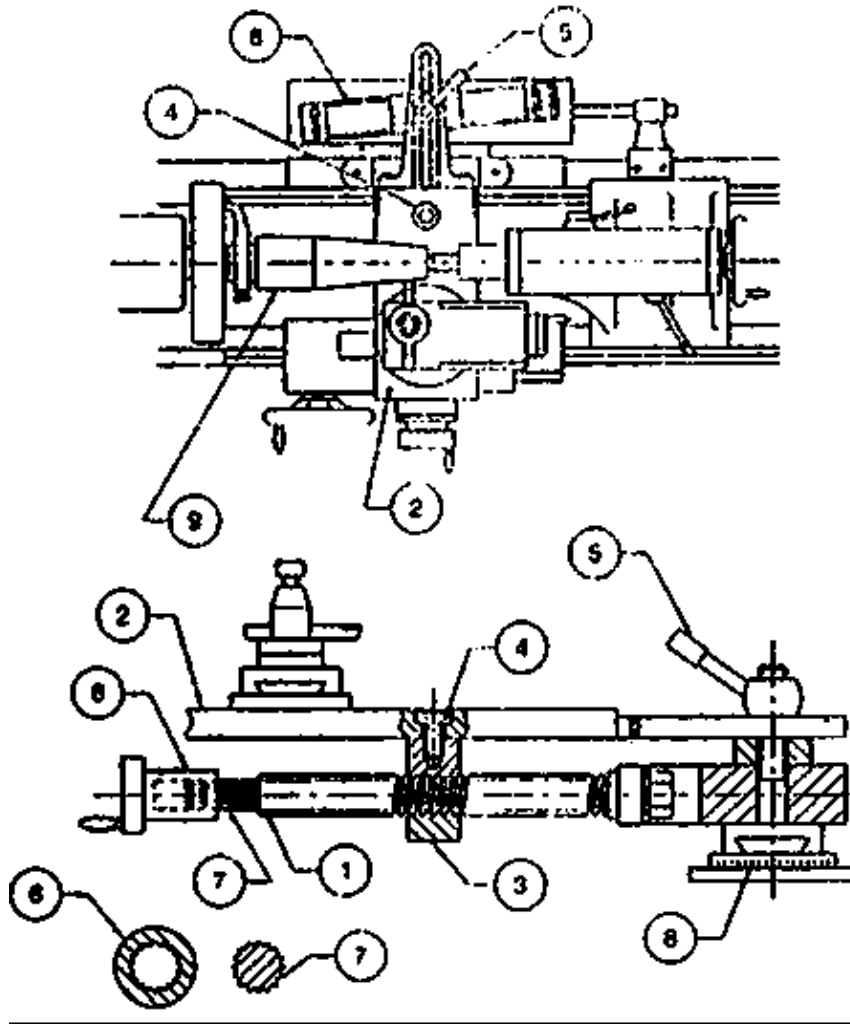

The screw rod (1) is linked to cross slide (2) through a box nut (3) and screw (4). One end of the cross slide is connected to the taper attachment with a binding screw (5) and the other end the cross slide handle is assembled with a spline (6 & 7 – hole and shaft). The guide bar (8) is set to an angle equal to the angle of taper on job (9). The taper attachment is centrally located to cover the length of taper on job.

After locking the cross slide to the taper attachment, the machine is switched on to give automatic feed. The tool will move in an inclined direction equal to the angle set on guide bar (8). In this case, there is no need to remove the screw (4) and de-link the box nut, because, for the movement of the cross slide screw rod and handle are assembled with a spline construction (6 & 7) one end of the screw rod is connected to the guide bar assembly. Depth of cut can be given by the cross slide.

DOUBLE START THREAD (CATCH PLATE METHOD)

TR 01 15 04 01 95

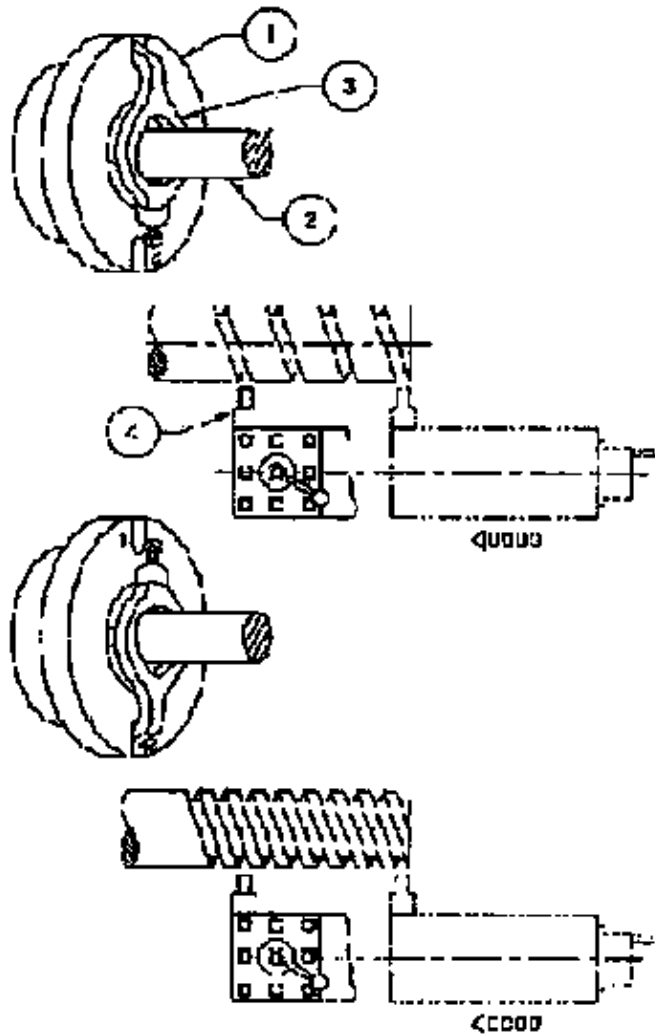

A catch plate (1) with two slots in the opposite sides (180° apart) is mounted on the lathe. Job (2) is held between centres accommodating the tail of the carrier (3) in slot No.1. Calculate the lead of the thread and cut the 1st start to the required depth.

Stop the machine and remove the job along with the dog carrier. Re-set the job accommodating the tail of the carrier in slot No.2. Now, the tool will come exactly in the middle of the two grooves. Cut the 2nd start of the thread.

Note: The two slots formed on the catch plate in the opposite sides (180° apart) are marked as 1 and 2.

DOUBLE START THREAD (DIVIDING THE GEAR METHOD)

TR 01 15 04 02 95

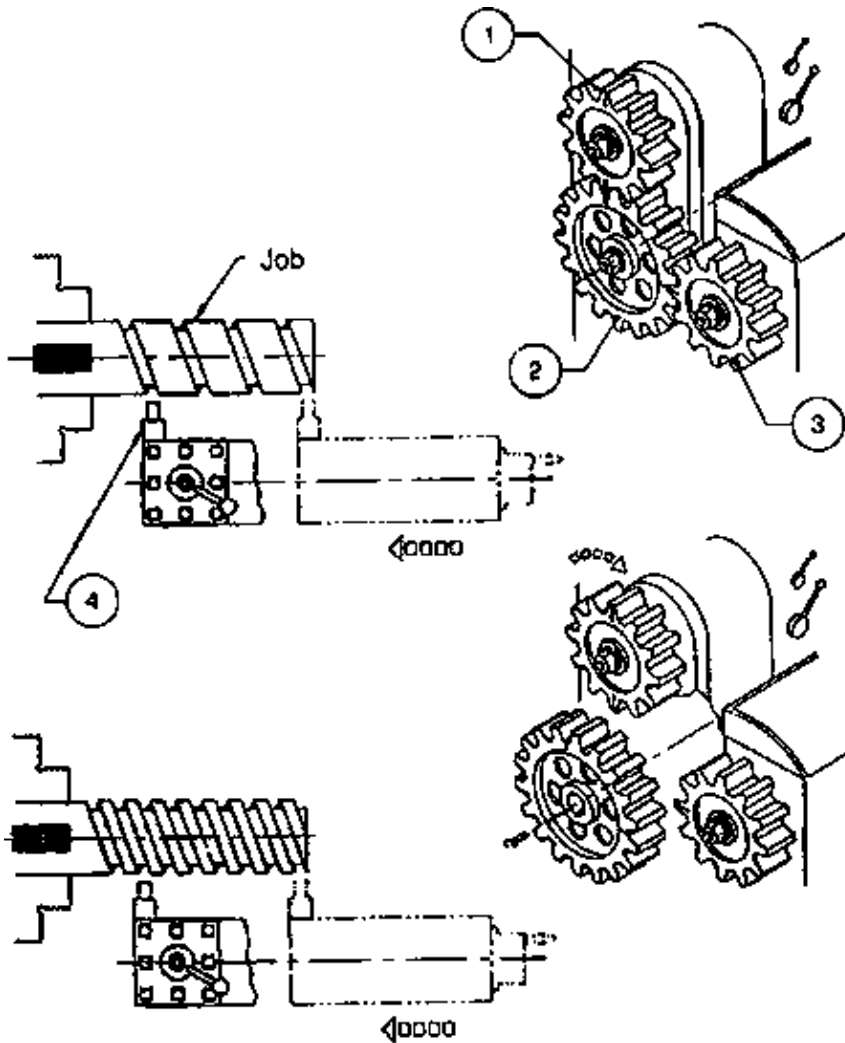

The gear train should be such that the gear teeth in the driver gear (1) must be divisible by two. Calculate the lead of the thread and cut the 1st start to the required depth. Then stop the lathe. Open the rear guard. Mark the driver gear (1) teeth into two so that there are equal number of teeth on either sides. One at the bottom where driver gear (1) meshes with intermediate gear (2). The other is exactly on the opposite side.

Make another chalk mark between two gears where intermediate gear (2) and lead screw gear (driven) (3) meshes.

Remove the intermediate gear (2) and rotate the driver gear (1) exactly half turn. While doing this the job also rotates half turn. Re-fix the intermediate gear so that the chalk marks matches. Now, the tool (4) will come exactly in the middle of the two grooves of the 1st thread.

DOUBLE START THREAD (GRADUATED COLLAR METHOD)

TR 01 15 04 03 95

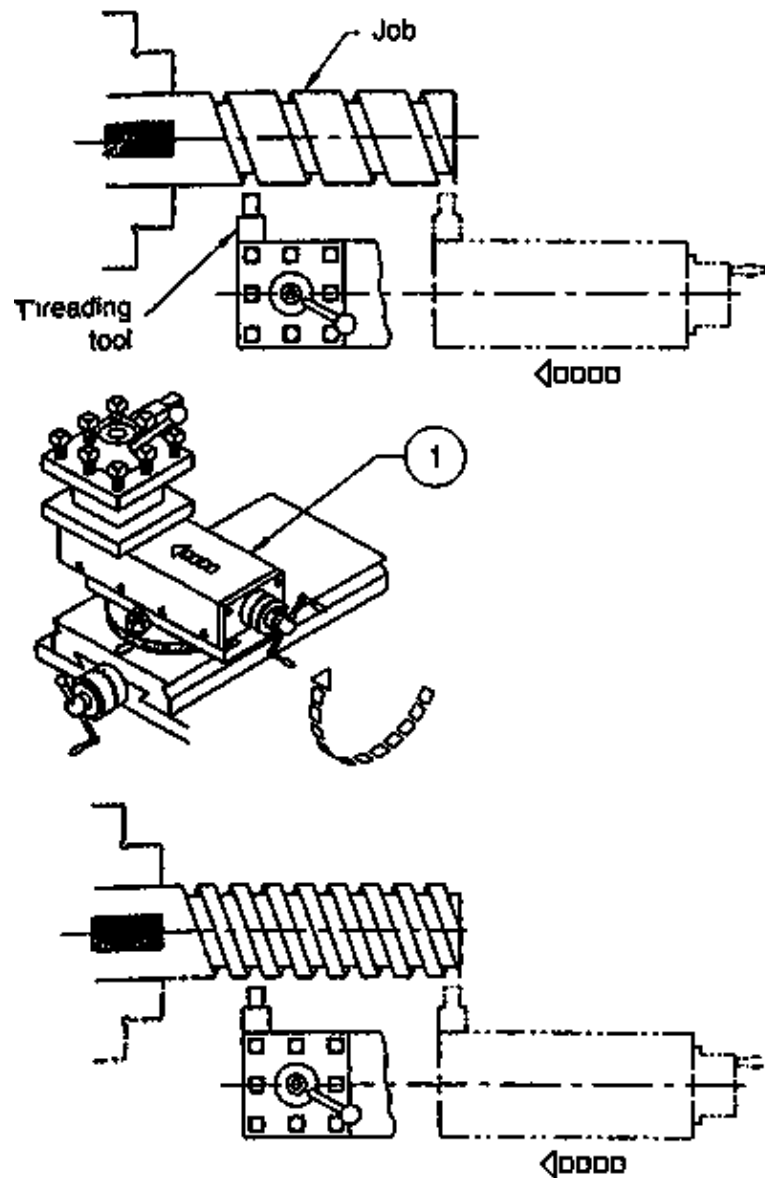

Calculate the lead of the thread. Arrange gear train and cut the 1st start of the thread to the required depth. Stop the machine and move the compound slide (1) forward to the half the lead of the thread. For this, use graduated collar of the compound rest. Now, the tool will come exactly in the middle of the two grooves of the 1st thread. Cut the 2nd start.

THREAD CUTTING BY HALF ANGLE METHOD (PRINCIPLE)

TR 01 15 04 04 95

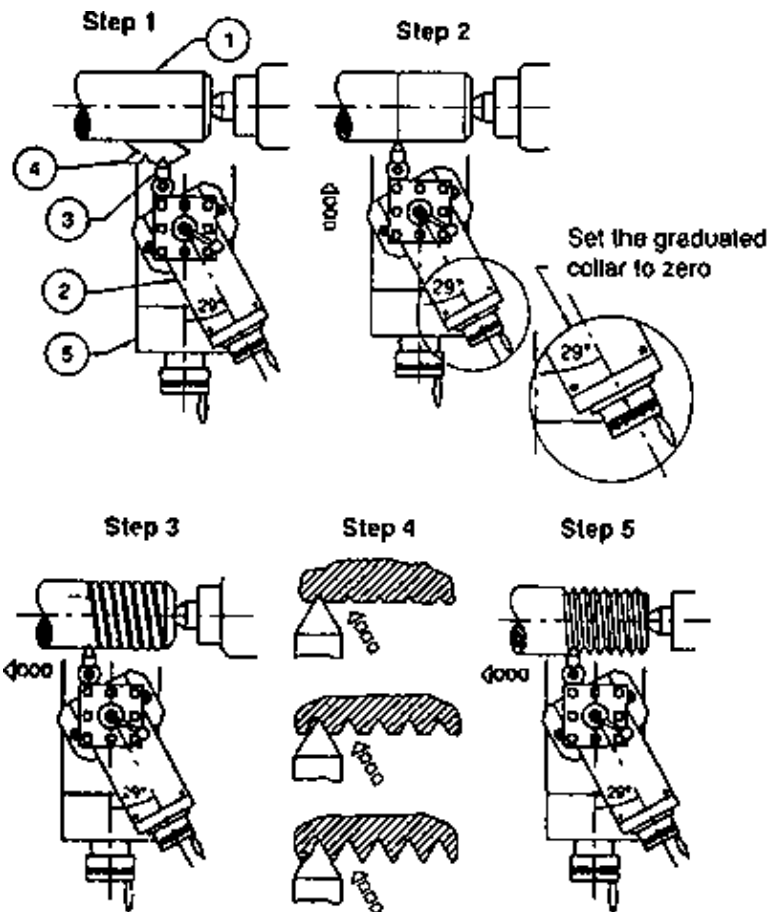

Step 1: Turn the job (1) to the required diameter before thread cutting operation is started. Tilt the compound rest (2) to 29° perpendicular to the job axis. The cutting tool (3) is set perpendicular to the job axis with the help of centre gauge (4).

Step 2: Start the machine. Using cross-slide (5), bring the tool very close to the job and touch lightly. Set the graduated collar of the compound rest to zero.

Step 3: Take the tool to the starting point and give a light threading cut. Depth of cut is given by compound rest (2).

Step 4: Take number of cuts using compound rest to form the thread.

Step 5: Give the final cut and complete the thread formation.

Turning

Table of Contents

<u>Turning</u>	1
<u>Turning – 18 Transparencies</u>	1

Turning

Turning – 18 Transparencies

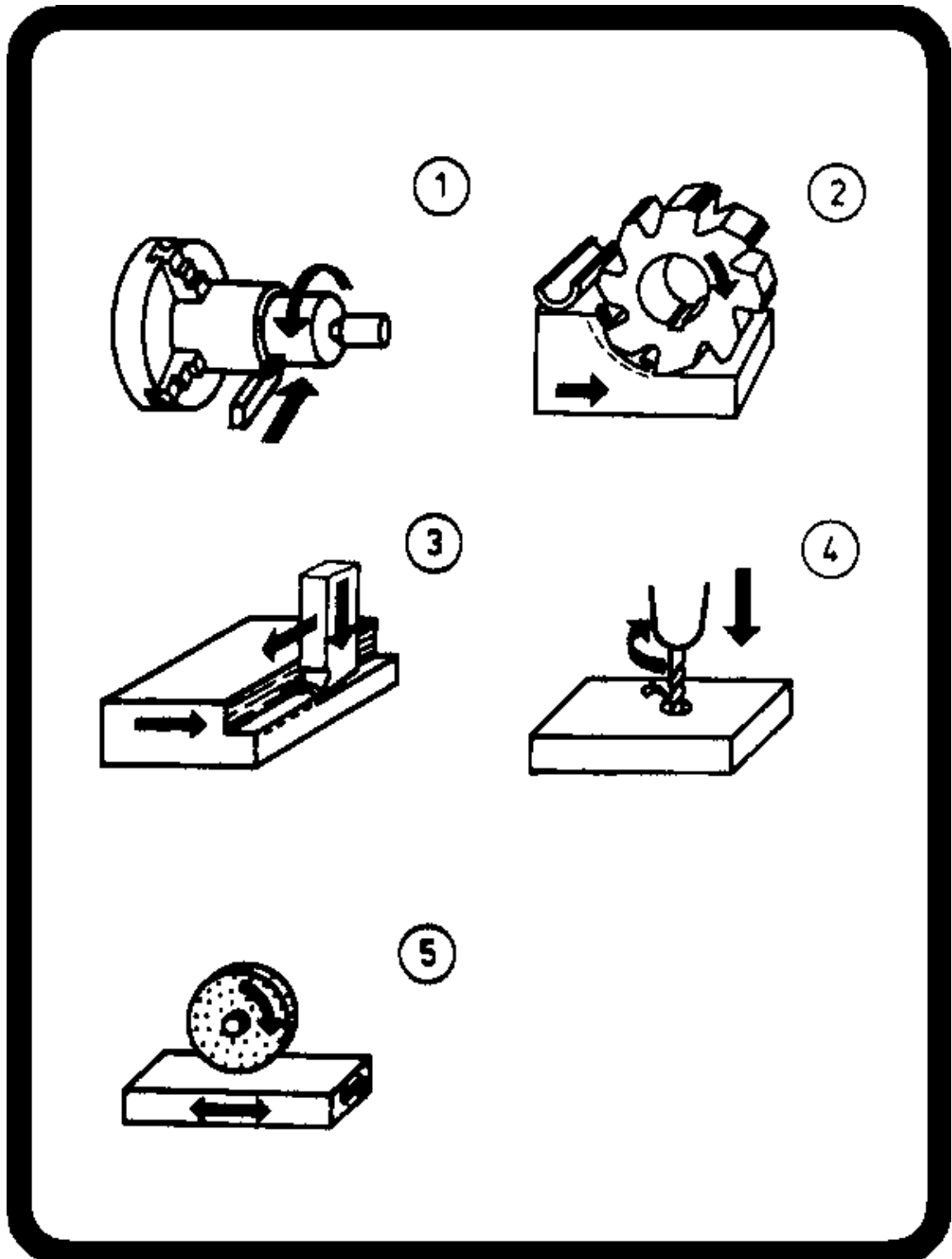

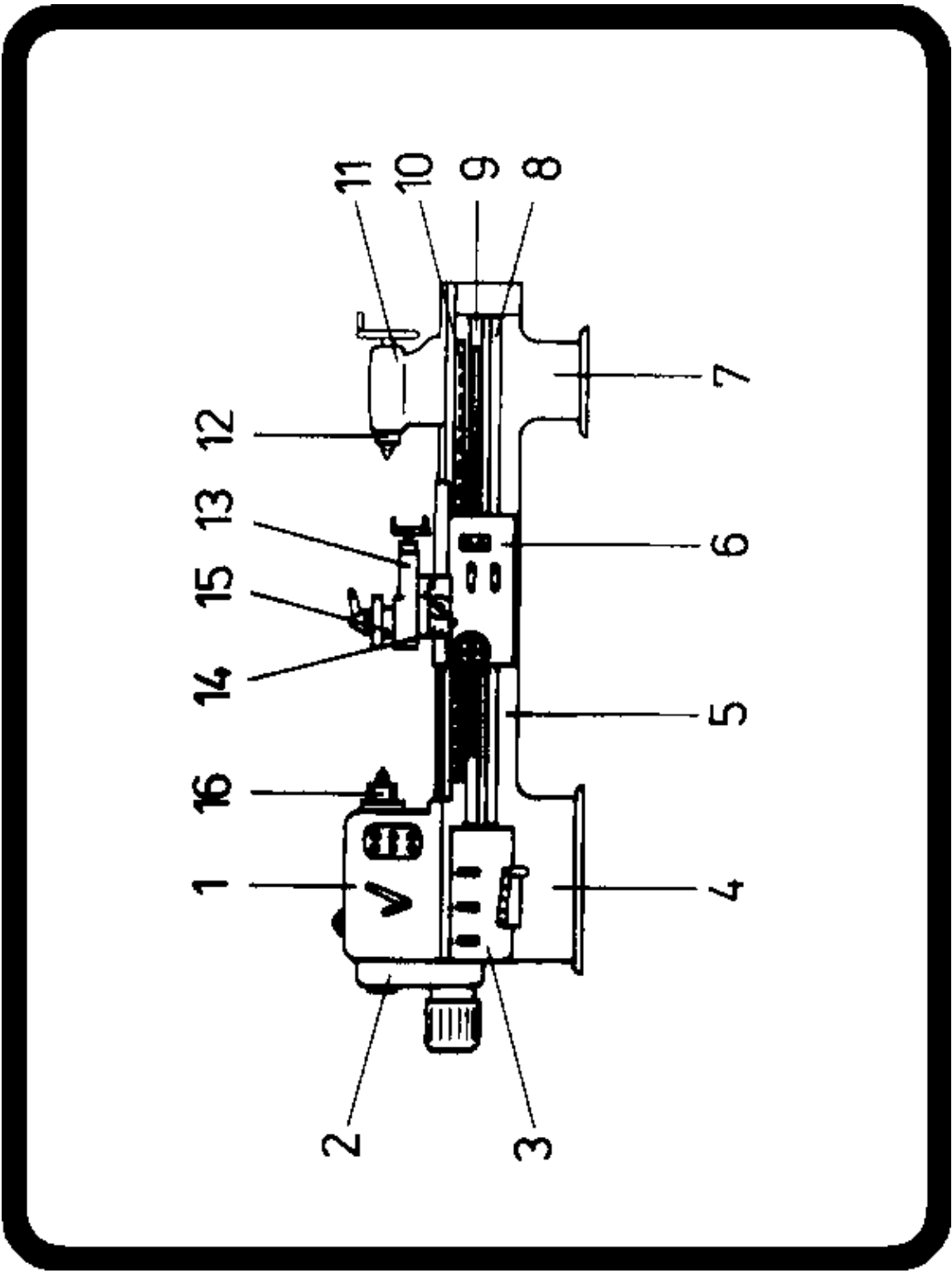

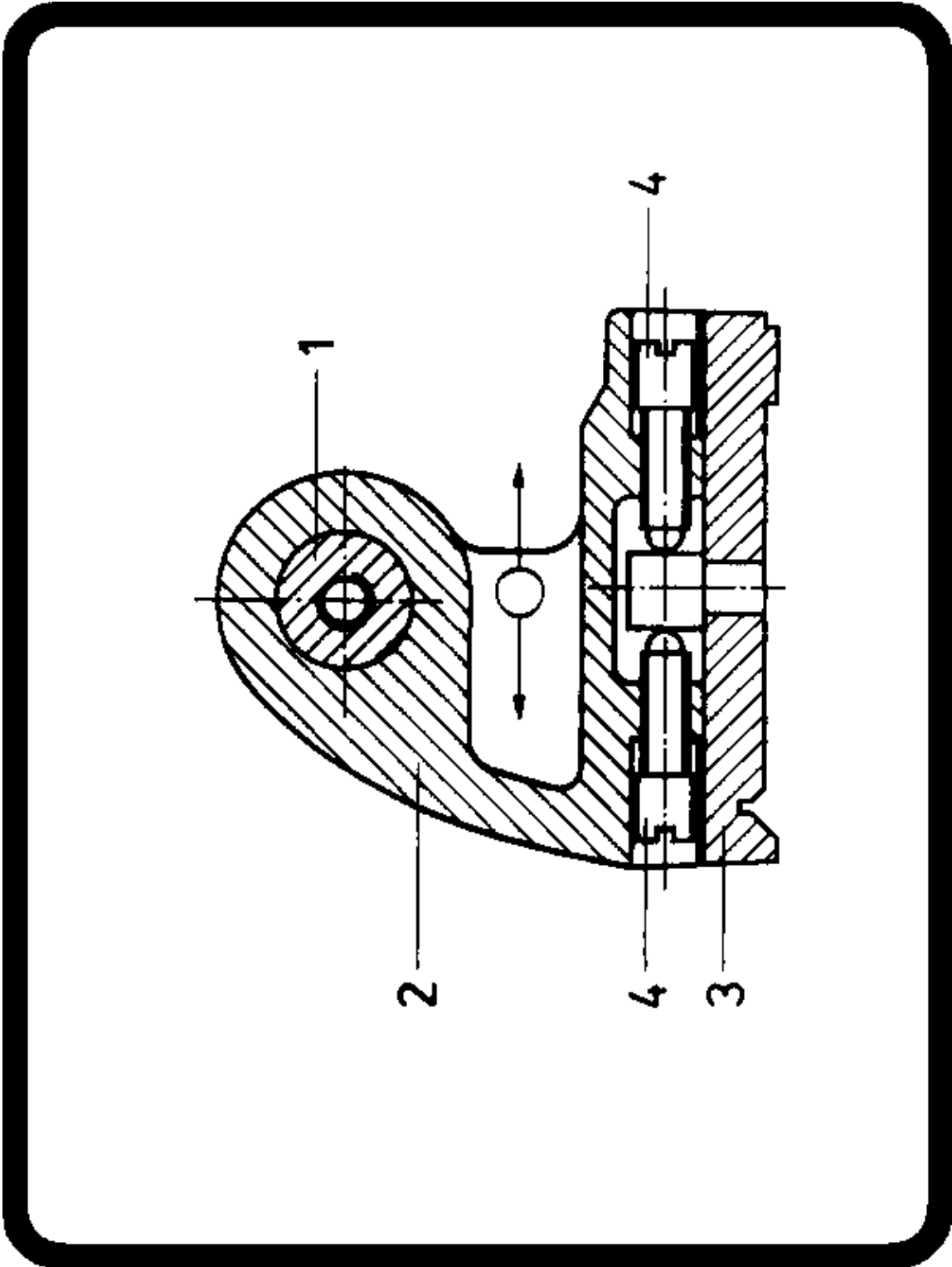

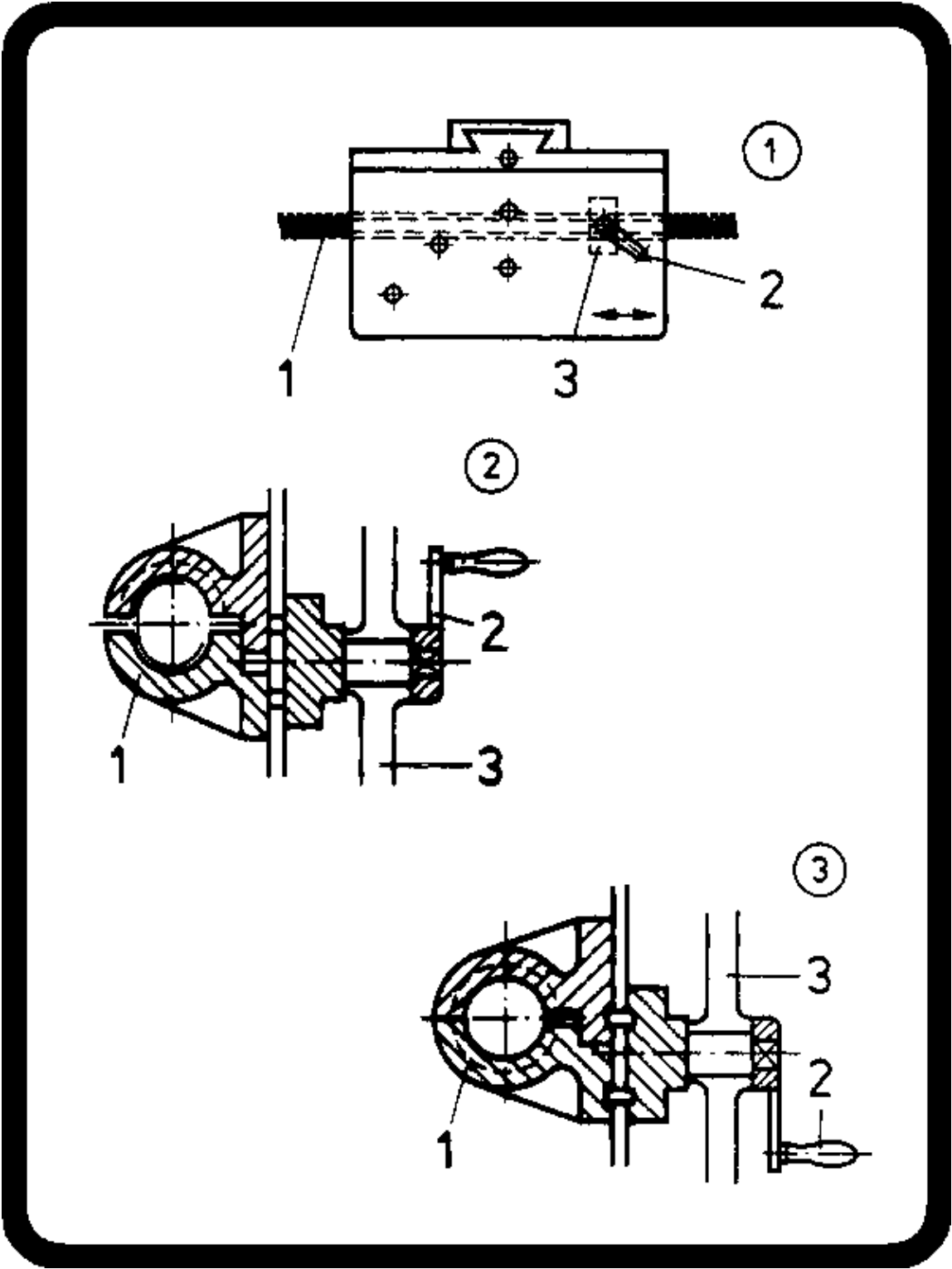

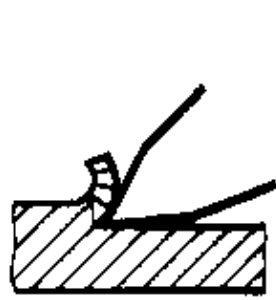

①



②

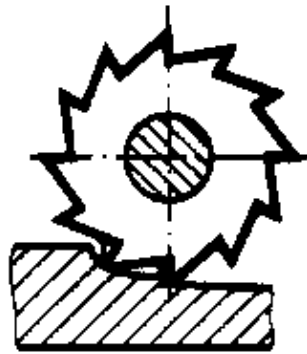

③

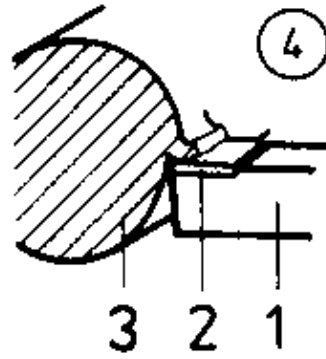

④

3 2 1

