

Machinist 1st Year – Transparencies

Table of Contents

<u>Machinist 1st Year – Transparencies</u>	1
<u>Vernier caliper Parts and Principle – TR 01 02 01 01 98</u>	1
<u>Reading of Vernier Caliper – TR 01 02 01 02 98</u>	1
<u>Reading of Vernier Caliper (Assignments) – TR 01 02 01 03 98</u>	2
<u>Micrometer parts and graduations – TR 01 02 02 01 98</u>	3
<u>Reading of Micrometer (Outside) – TR 01 02 02 02 98</u>	3
<u>Vernier Bevel Protractor parts and principle – TR 01 02 03 01 98</u>	4
<u>Vernier Bevel Protractor (Reading) – TR 01 02 03 02 98</u>	5
<u>Vernier Bevel Protractor (Applications) – TR 01 02 03 03 98</u>	7
<u>Depth Micrometer Parts and Reading – TR 01 02 06 01 98</u>	7
<u>Cutting speed, R.P.M. and Feed of drills – TR 01 05 01 01 98</u>	8
<u>Limits and Fits – Terminology – TR 01 06 01 01 98</u>	10
<u>Method of indicating surface roughness – TR 01 02 12 01 98</u>	10
<u>Classes of fits – TR 01 06 01 03 98</u>	12
<u>Basic shaft system (Shaft basis) – TR 01 06 01 04 98</u>	13
<u>Basic Hole System (Hole basis) – TR 01 06 01 05 98</u>	15
<u>Lathe parts and function – TR 01 12 01 01 98</u>	16
<u>Quick return motion of shaper – TR 01 16 02 01 98</u>	17
<u>Feed mechanism of a shaper – TR 01 16 03 01 98</u>	18
<u>Hydraulic Shaper Mechanism – TR 01 16 06 01 98</u>	18
<u>Relationship of Helix angle & force acting – TR 01 19 02 01 98</u>	20
<u>Up milling and Down milling – TR 01 19 04 01 98</u>	21
<u>Dividing Head Parts and Functions – TR 01 19 05 01 98</u>	22
<u>Elements of a Spur Gear I – TR 01 20 02 01 98</u>	22
<u>Elements of a Spur Gear II – TR 01 20 02 02 98</u>	23
<u>Gear Tooth Vernier Caliper & its Application – TR 01 20 03 01 98</u>	25

Machinist 1st Year – Transparencies



Directorate General of
Employment and Training
Ministry of Labour, Govt. of India

Deutsche Gesellschaft für Technische
Zusammenarbeit (GTZ), GmbH
German Technical Co-operation



Developed by

CENTRAL INSTRUCTIONAL MEDIA INSTITUTE

P.O. Box. 3124, 76, GST Road, Guindy, Chennai – 600 032. Phone: 234 5256, 234 5257. Fax: (0091-44) 234 2791

Vernier caliper Parts and Principle – TR 01 02 01 01 98

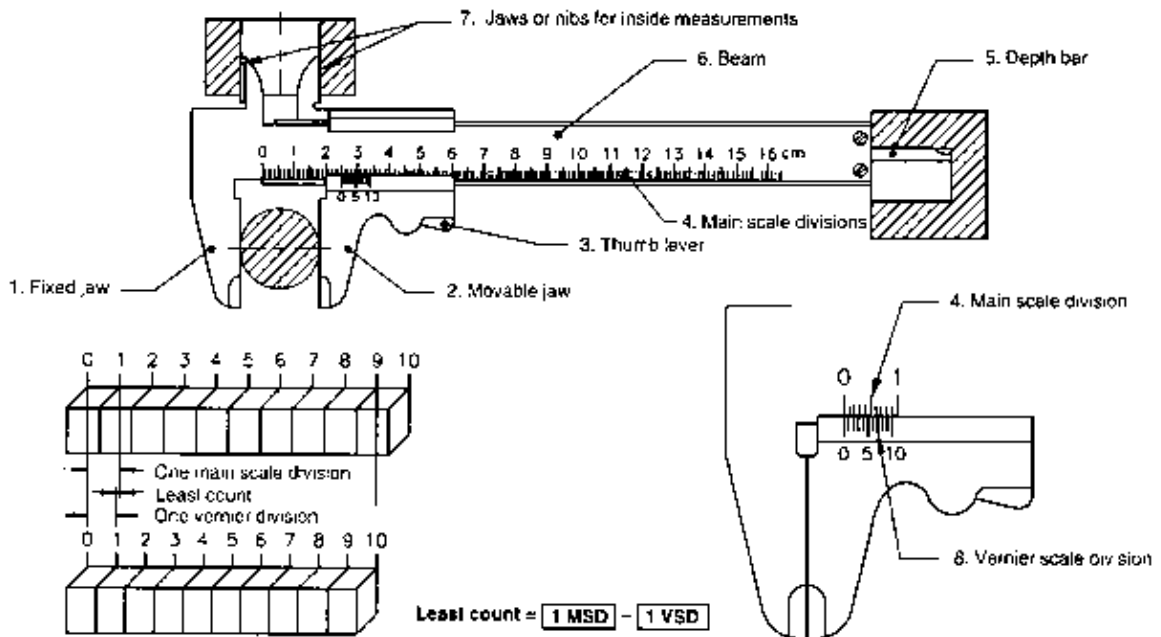

Reading of Vernier Caliper – TR 01 02 01 02 98

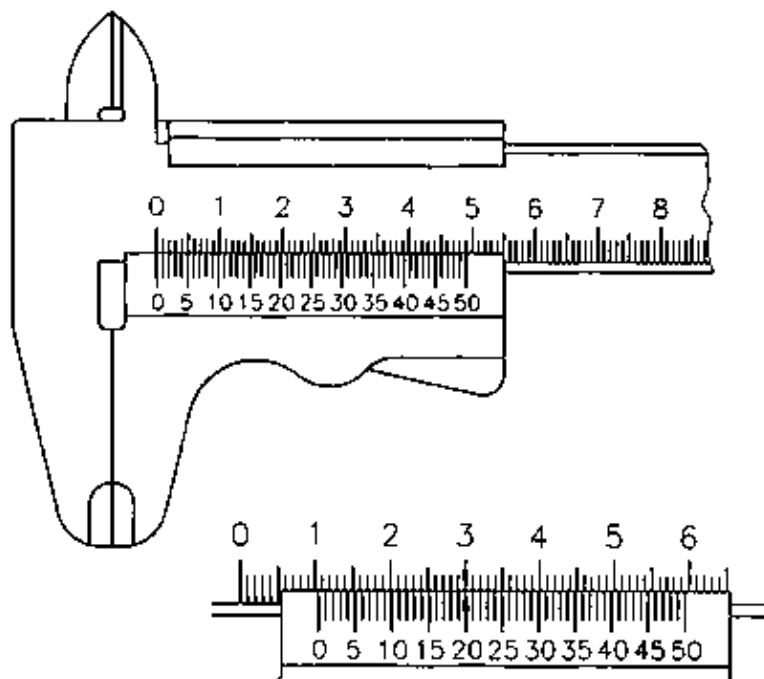

49 Main scale divisions are divided into 50 vernier scale divisions

Value of 1 VSD $= \frac{49}{50} \text{ mm}$

Least count $= 1 \text{ MSD} - 1 \text{ VSD}$
 $= 1 - \frac{49}{50}$
 $= \frac{1}{50} = 0.02 \text{ mm}$

Main scale reading $= 10.00 \text{ mm}$

No of VSD coinciding with MSD $= 20$

Value of coinciding vernier division $= 00.40 \text{ mm}$

Reading $= \text{MS Reading} + \text{VS Reading}$
 $= 10.00 + 0.40 \text{ mm}$
 $= 10.40 \text{ mm}$

Reading of Vernier Caliper (Assignments) – TR 01 02 01 03 98

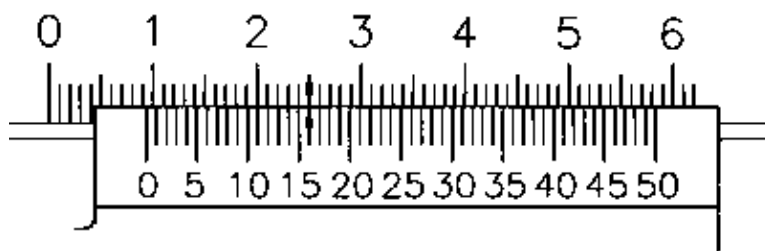

Main scale reading $= 9.00 \text{ mm}$

Value of coinciding vernier division $= 0.32 \text{ mm}$

Reading $= 9.32 \text{ mm}$

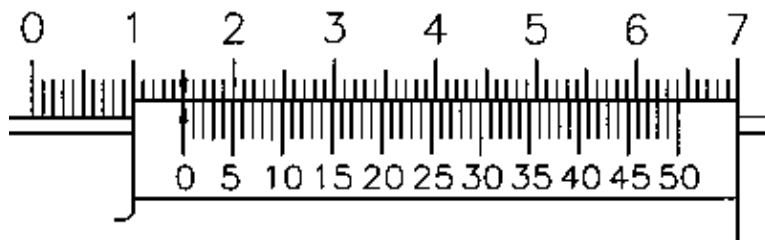

Main scale reading $= 15.00 \text{ mm}$

Value of coinciding vernier division $= 0 \text{ mm}$

Reading $= 15.00 \text{ mm}$

Micrometer parts and graduations – TR 01 02 02 01 98

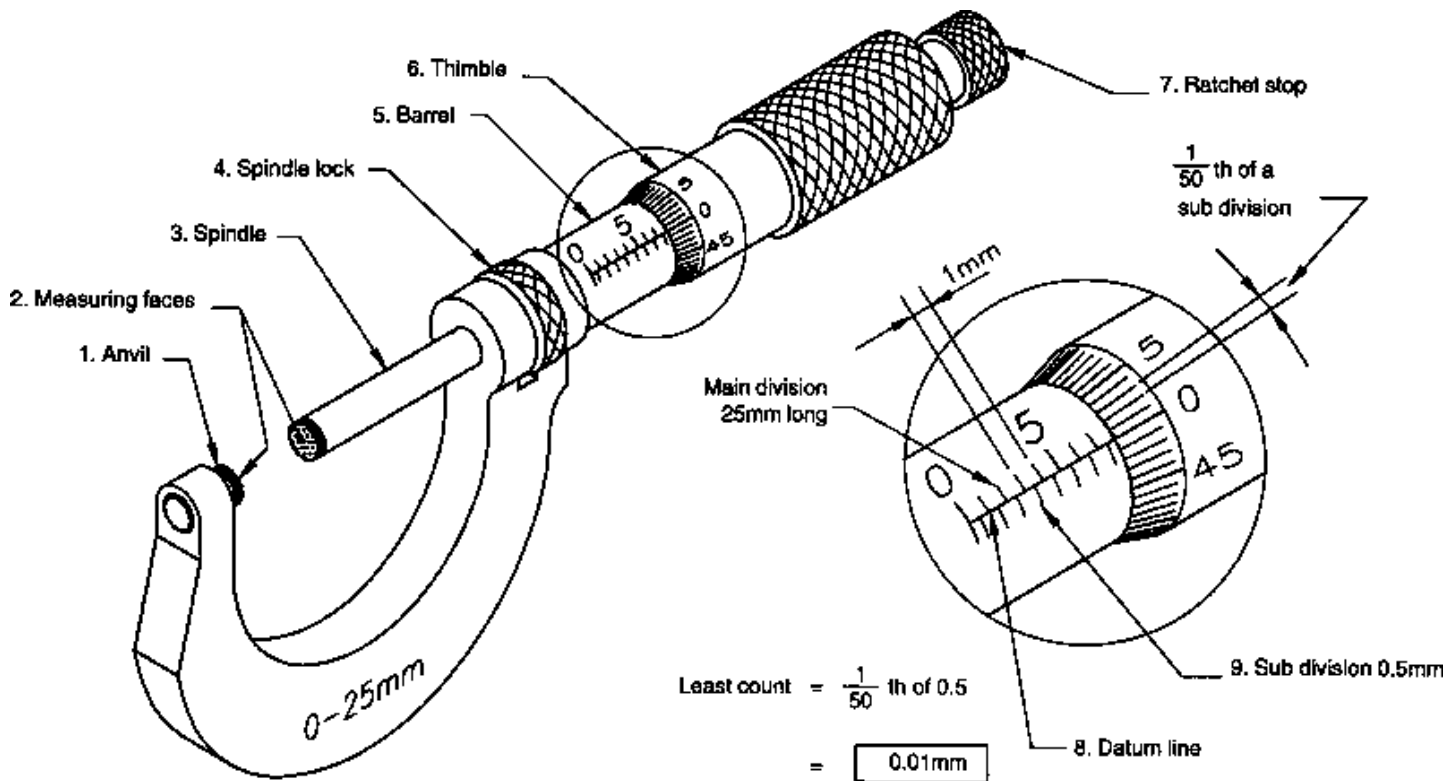

The range of the Micrometer is 0 – 25 mm.

Reading of Micrometer (Outside) – TR 01 02 02 02 98

Main divisions
2 x 1mm = 2.00 mm

Thimble divisions
25 x 0.01 mm = 0.25 mm

Sub division
0 x 0.5mm = 0.5 mm

Main divisions	= 2 x 1 mm	2.00 mm
Sub division	= 1 x 0.50 mm	0.50 mm
Thimble divisions	= 25 x .01 mm	

0.25
mm

Reading = 2.75
mm

EXAMPLE

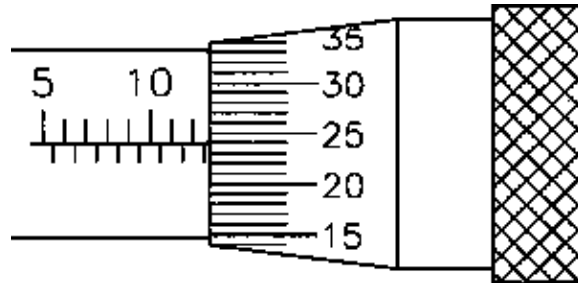

Main divisions = $12 \times 1 \text{ mm}$ = 12.00
mm

Sub division = $1 \times 0.50 \text{ mm}$ = 0.50
mm

Thimble divisions = $24 \times 0.01 \text{ mm}$ = 0.24
mm

Reading = 12.74
mm

Vernier Bevel Protractor parts and principle – TR 01 02 03 01 98

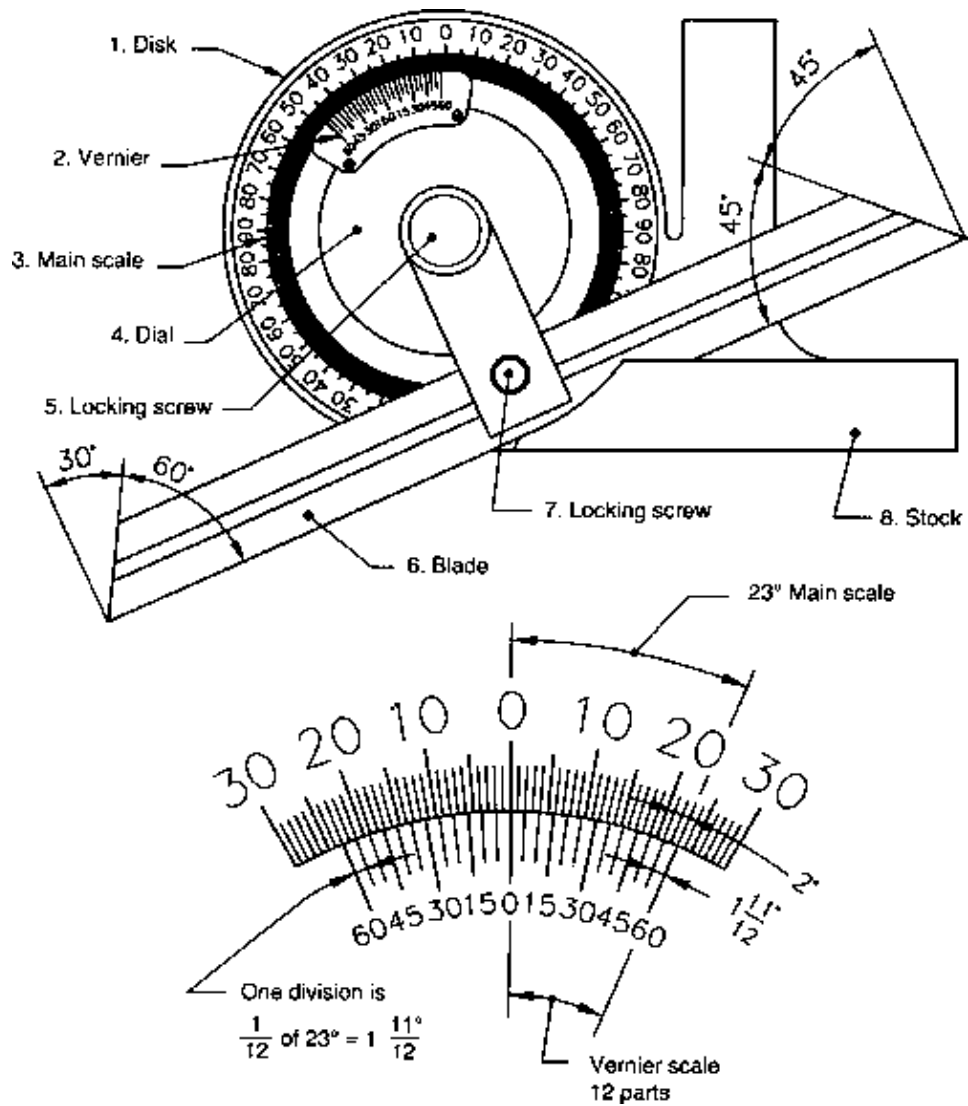

The full circumference of the disk is graduated into 360 equal parts.

The value of each division on the disk is = 1 ° (Main scale division)

23° of the main scale division is divided into 12 equal parts on the vernier scale.

The value of each vernier scale division is $= \frac{23^\circ}{12}$ or $1^\circ 55'$

Least count is $= 2^\circ - \frac{23^\circ}{12} = \frac{1^\circ}{12}$ or $5'$

Note: Value of one VSD ($1^\circ 55'$) is more than 1° (MSD). Hence 2 MSD (2°) are taken

Vernier Bevel Protractor (Reading) – TR 01 02 03 02 98

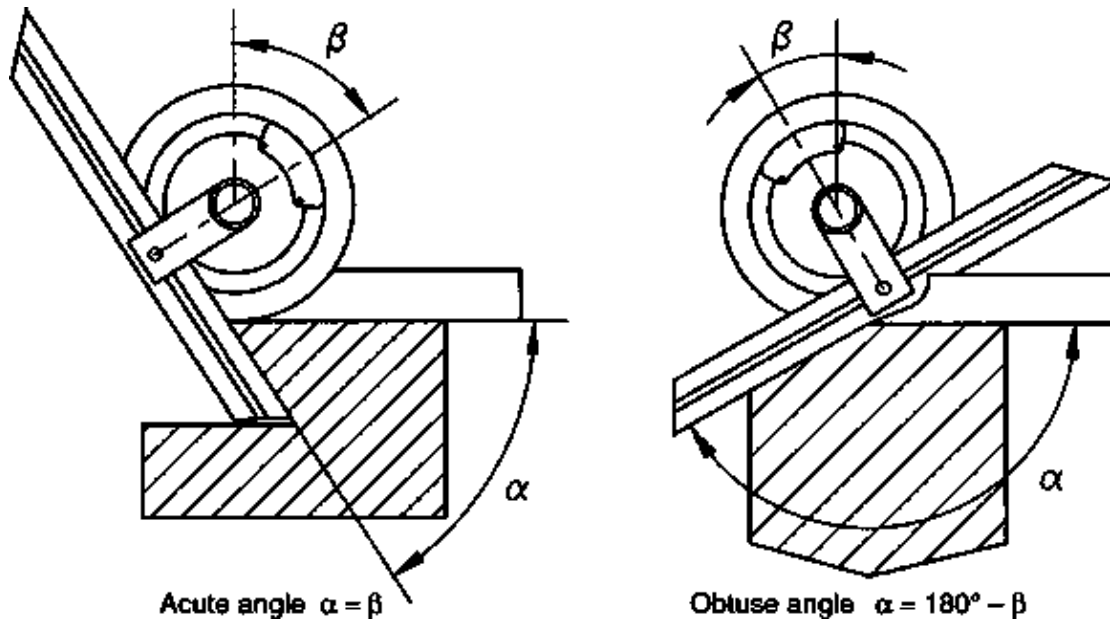

ASSIGNMENTS



MSD = 54°
 Value of VSD = $25'$
 Reading = $54^\circ 25'$



MSD = 60°
 Value of VSD = $55'$
 ? = $180^\circ - 60^\circ 55'$
 Reading = $119^\circ 5'$



MSD = 29°
 Value of VSD = 10'
 Reading = 29° 10'



MSD = 30°
 Value of VSD = 35'
 Reading = 30° 35'

Vernier Bevel Protractor (Applications) – TR 01 02 03 03 98

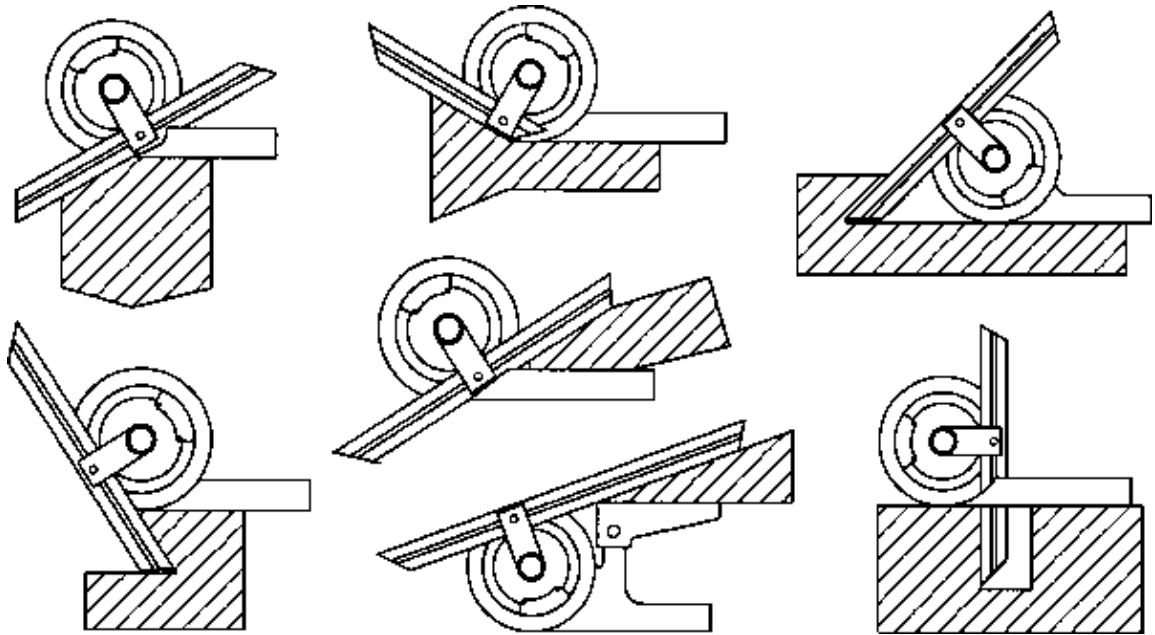

Depth Micrometer Parts and Reading – TR 01 02 06 01 98

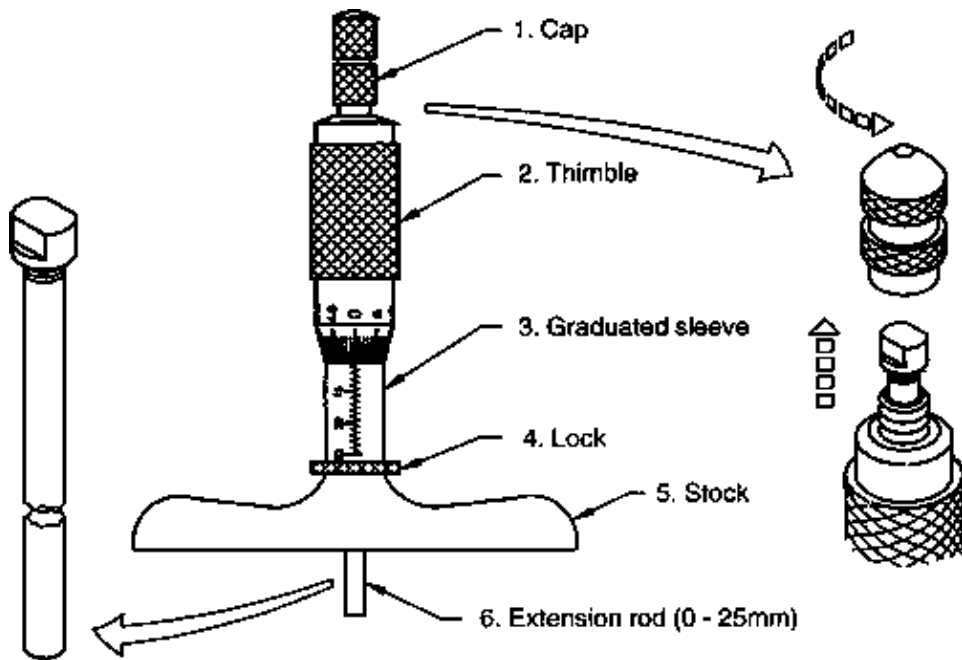

The extension rod face flushes with the stock when zero of thimble coincides with the zero of sleeve

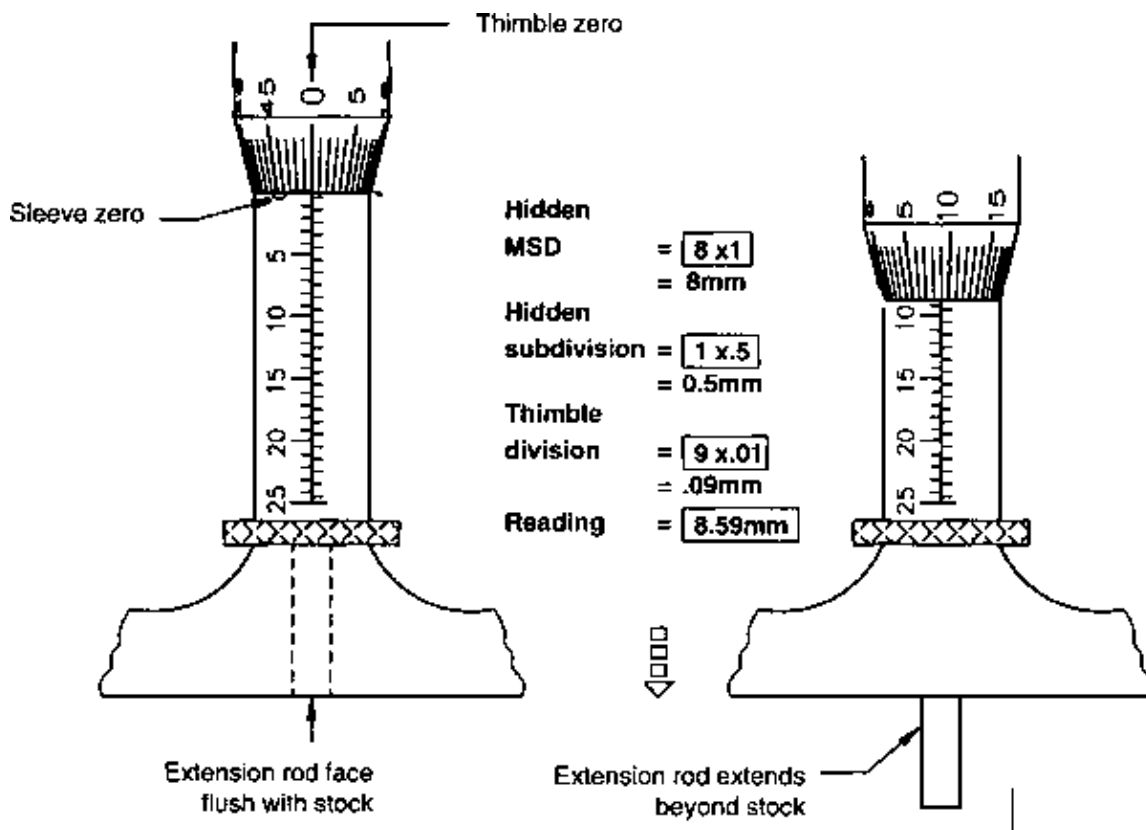

Cutting speed, R.P.M. and Feed of drills – TR 01 05 01 01 98

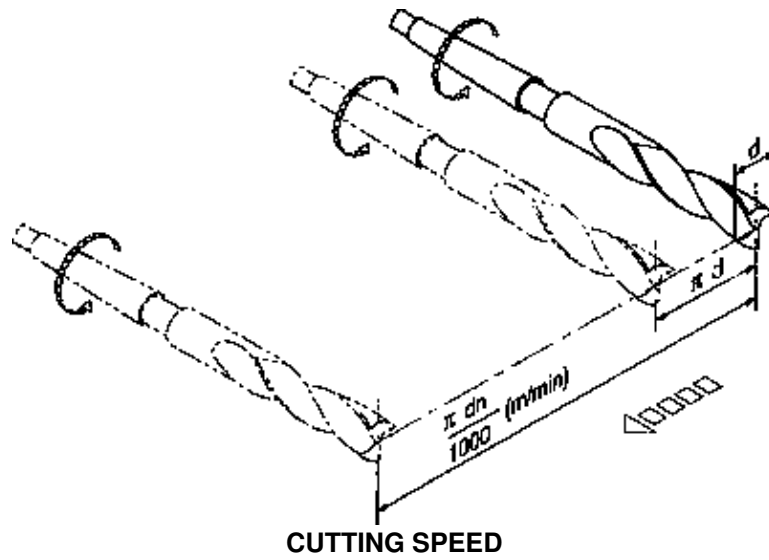

The cutting speed for drilling is the speed of the periphery of the cutting edge in m/min.

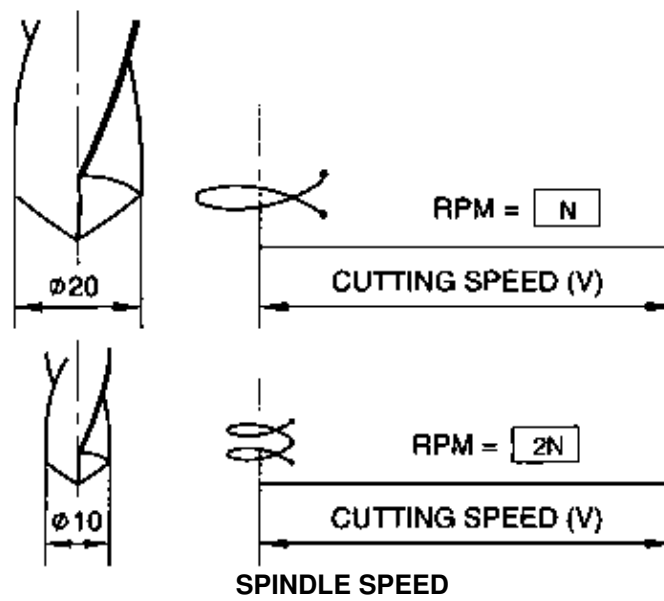

The RPM of the drill depends on the cutting speed and diameter of the drill.

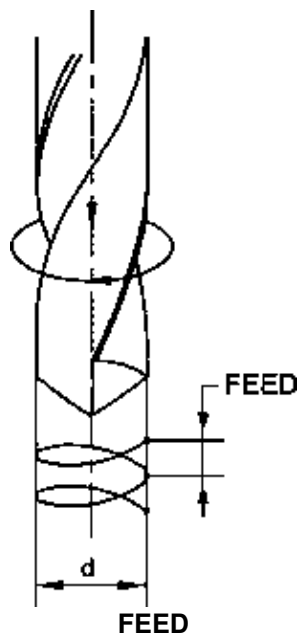

Feed is the distance that a drill advances into the work for each revolution.

Limits and Fits – Terminology – TR 01 06 01 01 98

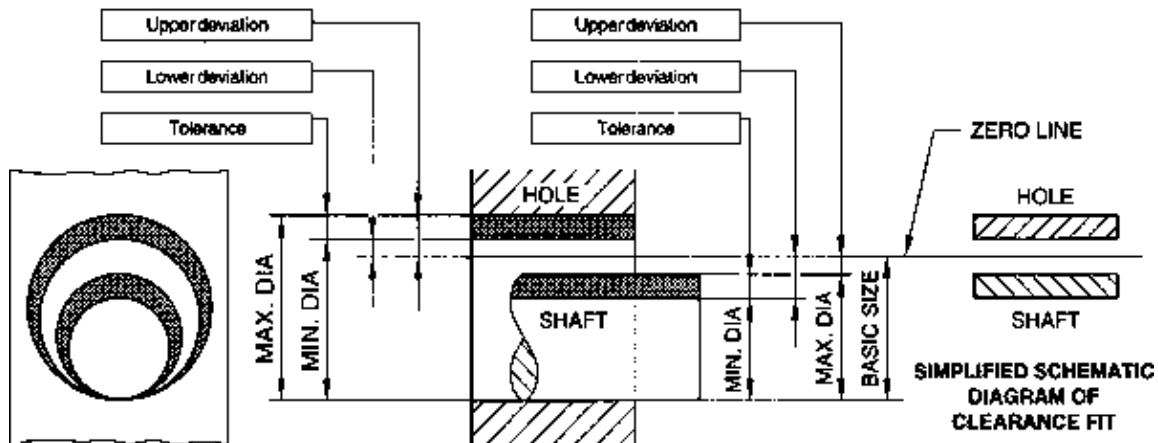

- The zero line is the line of zero deviation and represents the Basic size.
- The deviation which gives maximum limit of size is called Upper deviation.
- The deviation which gives minimum limit of size is called Lower deviation.
- By convention, when the zero line is drawn horizontally Positive deviations are shown above and Negative deviations are shown below it.

Method of indicating surface roughness – TR 01 02 12 01 98

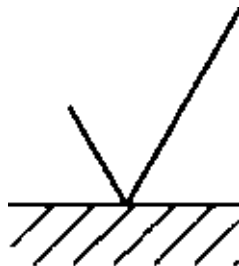

This is the basic symbol and has no meaning as it is.

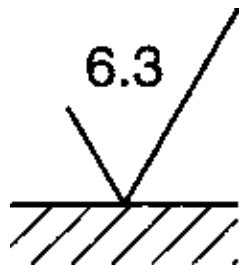

Should be followed by roughness value.

The roughness value may be obtained by any process

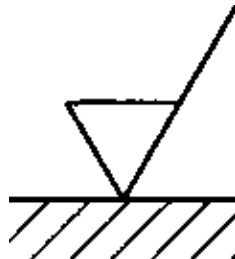

Removal of material is by machining only.

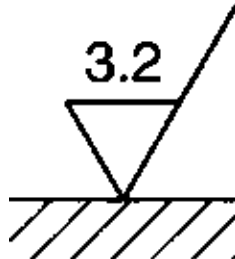

Should be followed by roughness value.

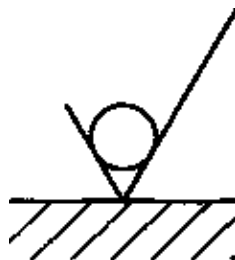

Removal of material is prohibited.

Surface finish is obtained by process (eg.) electroplating, burnishing, lapping etc.

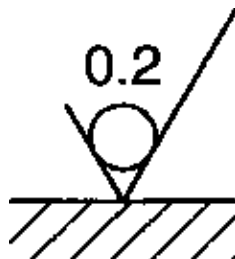

Roughness value must be obtained without removal of material.

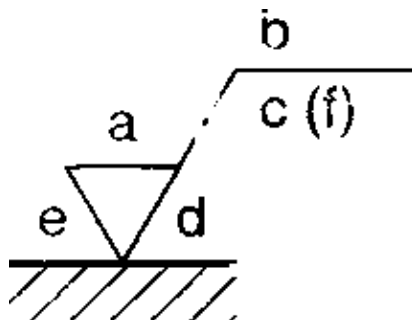

a = Roughness value R_a in micrometer or roughness grade number N1 to N2.

b = Production method, Treatment or coating

c = Sampling length,

d = direction of lay.

e = Machining allowance

f = Other roughness value (in bracket)

EXAMPLE

∇ N7 / all over
except where otherwise stated

OR

∇ N7 / (∇ N3 / ∇ N5)

OR

∇ N7 / (\checkmark)

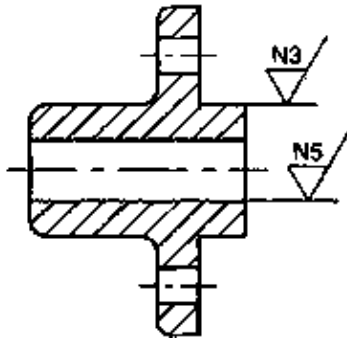

The surface roughness is indicated as follows:

– The notation “except where otherwise stated”

or

– The symbol or symbols of roughness which are exceptional to the general symbol are indicated on the corresponding surfaces.

or

– a basic symbol (in bracket) where otherwise stated.

Classes of fits – TR 01 06 01 03 98

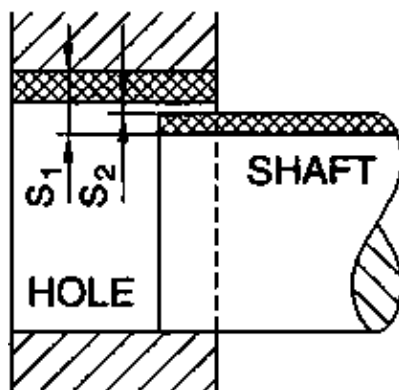

**SIMPLIFIED
REPRESENTATION**

CLEARANCE FIT

S_1 = Maximum Clearance

S_2 = Minimum Clearance

In a clearance fit the tolerance zone of hole will be always above the tolerance zone of shaft.

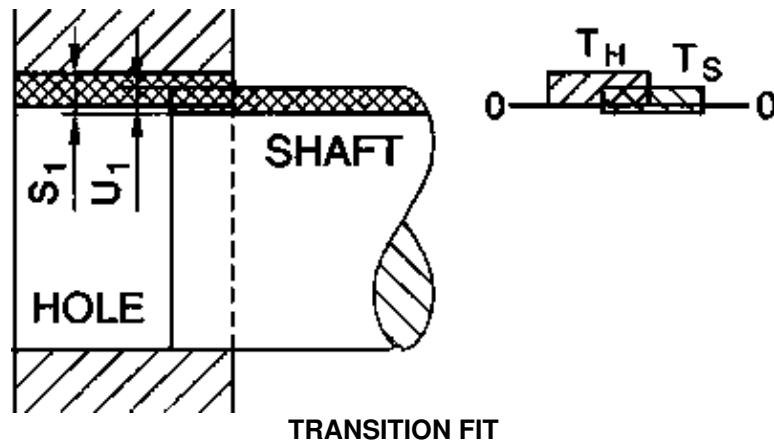

$S_1 =$ Maximum Clearance
 $U_1 =$ Maximum Interference

In a transition fit the tolerance zone of hole and tolerance zone of shaft will overlap.

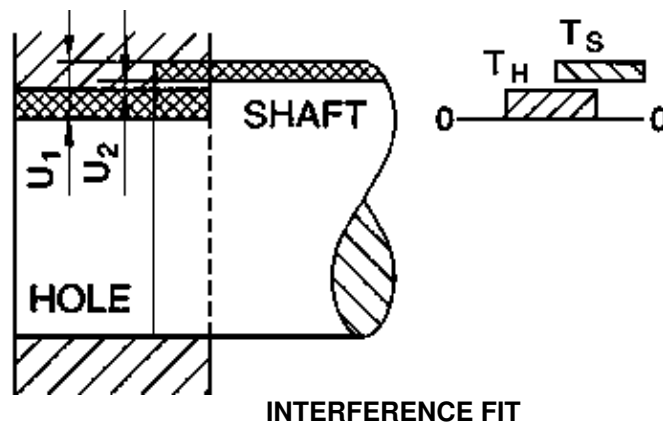

$U_1 =$ Maximum Interference
 $U_2 =$ Minimum Interference

In an interference fit the tolerance zone of hole will be always below the tolerance zone of shaft.

Basic shaft system (Shaft basis) – TR 01 06 01 04 98

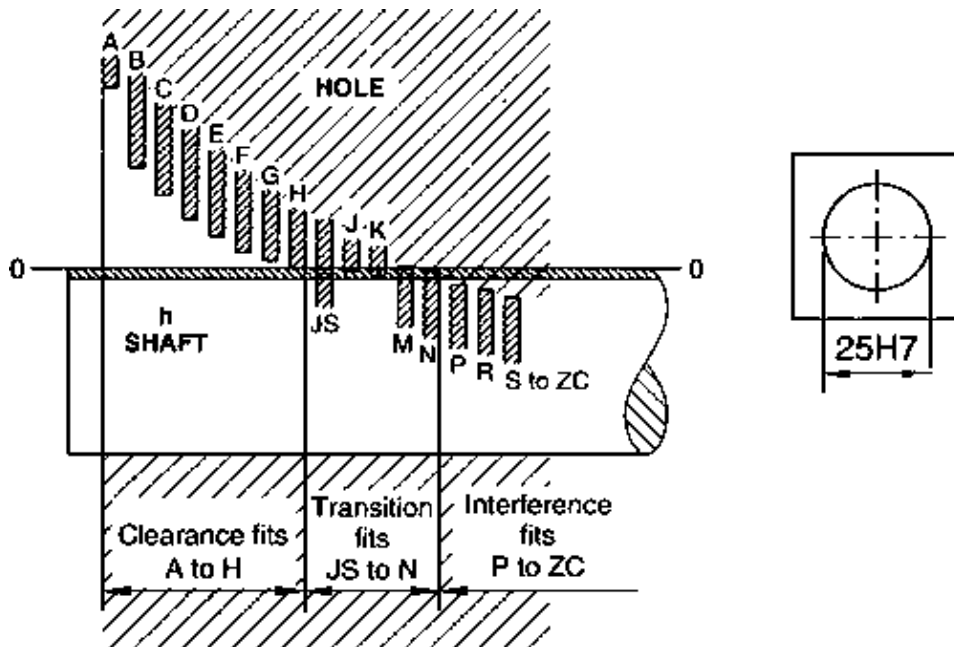

Capital letters A to ZC indicate 25 fundamental deviations for holes.

(A,B,C,D,E,F,G,H,JS,J,K,M,N,O,P,R,S,T,U,V,X,Y,Z,ZA,ZB,ZC) There are 18 grades of tolerances. (01,0,1....16)

- 25 mm is basic size
- 'H' is the fundamental deviation for hole
- '7' is the grade of tolerance

APPLICATION

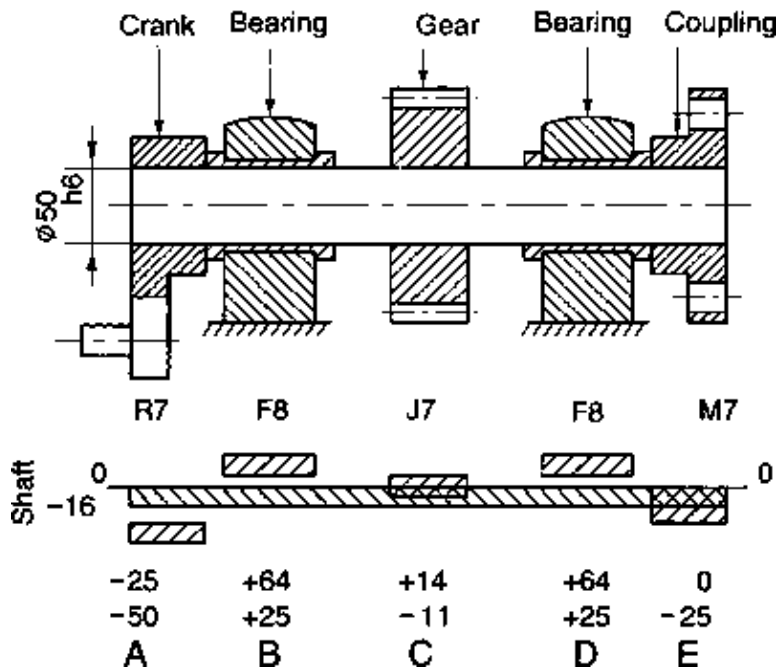

What is shaft basic system?

Different clearances and interferences are obtained in associating various holes with single shaft, whose upper deviation is zero. (symbol 'h')

Name the fit

- A Interference fit
- B Clearance fit
- C Transition fit
- D Clearance fit
- E Transition fit

Basic Hole System (Hole basis) – TR 01 06 01 05 98

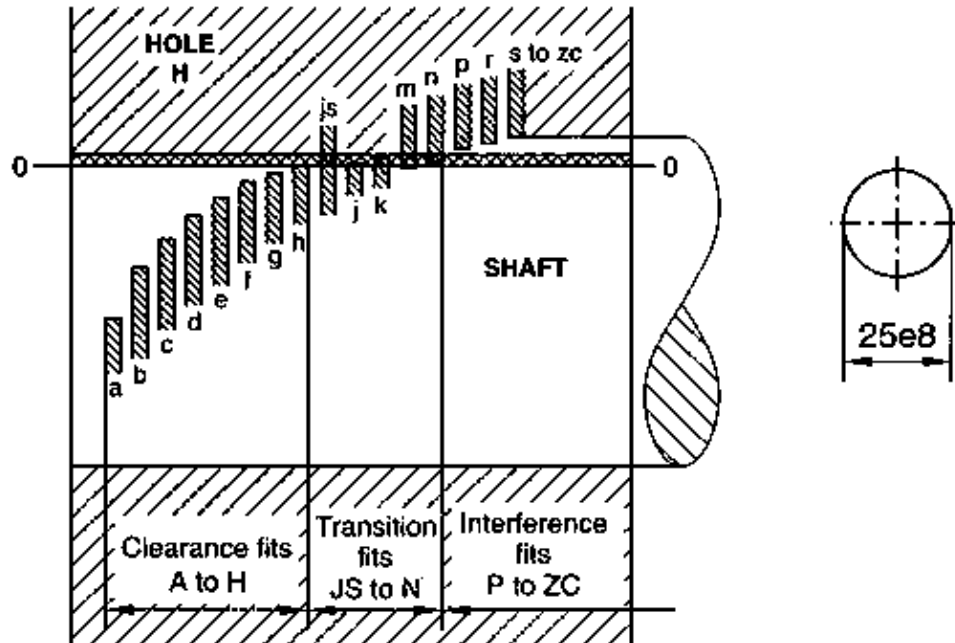

Small letters a to zc indicate 25 fundamental deviations for shafts.

(a,b,c,d,e,f,g,h,js,j,k,m,n,o,p,r,s,t,u,v,x,y,za,zb,zc) There are 18 grades of tolerances. (01,0,1.... 16)

- 25 mm is basic size
- 'e' is the fundamental deviation for shaft
- '8' is the grade of tolerance

APPLICATION

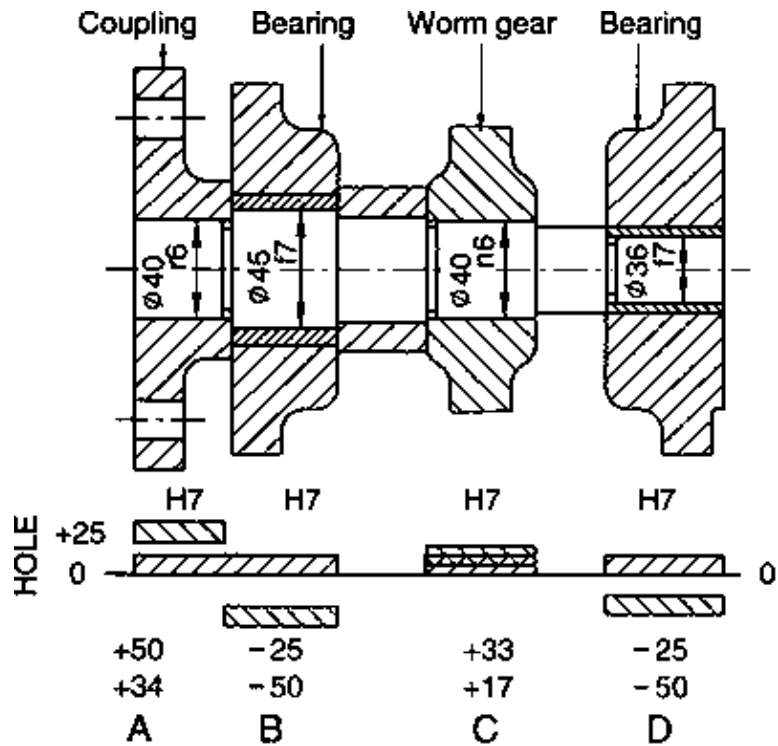

What is hole basic system?

Different clearances and interferences are obtained in associating various shafts with single hole, whose lower deviation is zero. (symbol 'H')

Name the fit

- A Interference fit
- B Clearance fit
- C Transition fit
- D Clearance fit

Lathe parts and function – TR 01 12 01 01 98

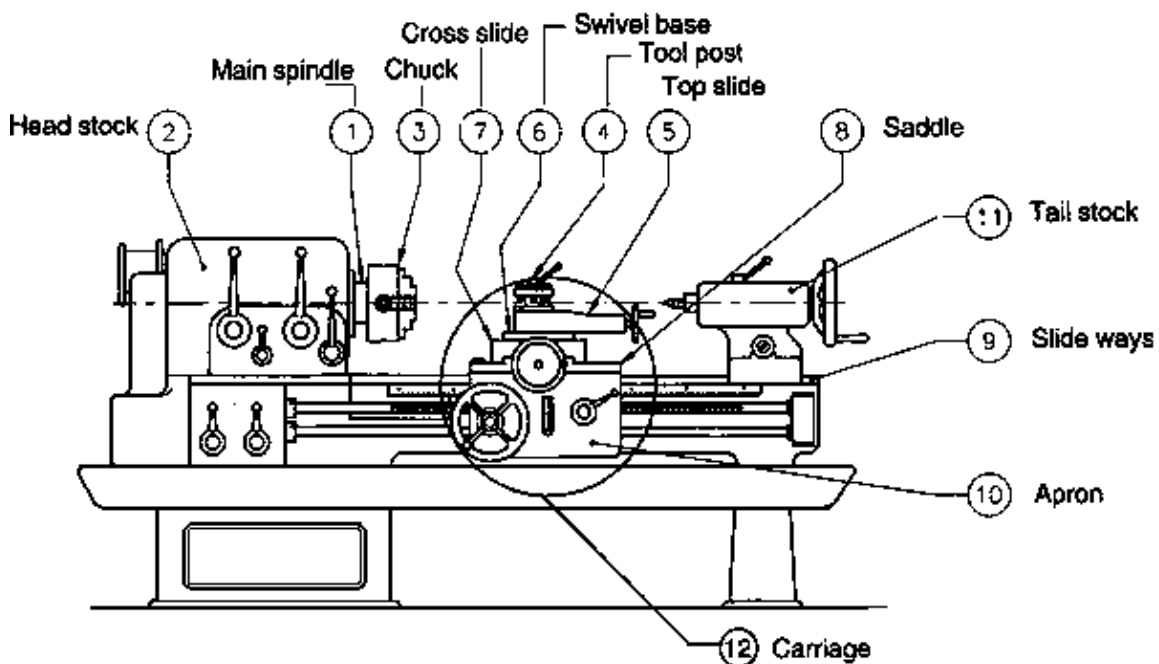

In the HEADSTOCK 2, the MAIN SPINDLE 1 is housed. The main spindle gets the drive from the Electric Motor. The work holding device chuck 3 is fitted at the one end of the main spindle. The TOOL POST 4 is mounted on the TOP SLIDE 5. The slide is fitted on a SWIVEL BASE 6. This helps to position or move the tool at any angle. The swivel base is assembled on the top of the CROSS SLIDE 7. The Cross Slide helps to move the tool perpendicular to the axis of the main spindle. The Cross slide is fixed on the SADDLE 8 which can be moved on the SLIDEWAYS of the bed 9. The CARRIAGE 12 consists of the APRON 10 which causes the feed control devices and all the devices used for tool movement. The TAILSTOCK 11 is mounted on the bed and can slide along the bed. The tailstock is used to support one end of long workpieces with the support of centres, holding cutting tools like drill, reamer and also to shift the axis of workpieces as required for taper turning.

Quick return motion of shaper – TR 01 16 02 01 98

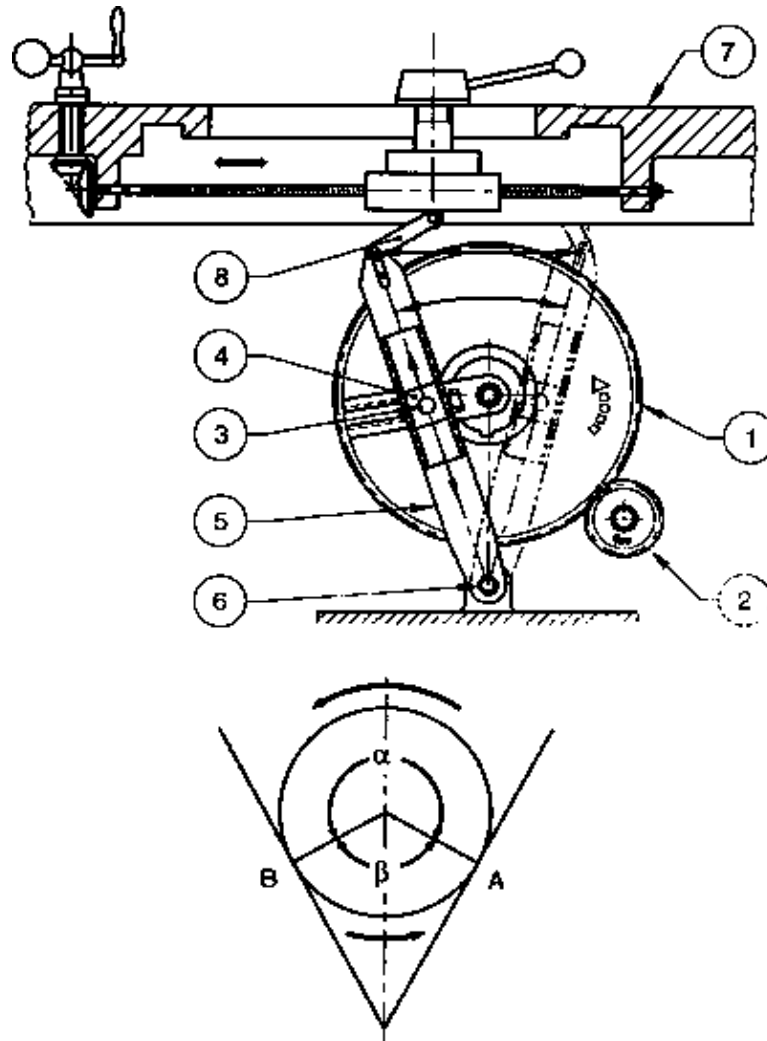

Bull gear (1) is driven by the Pinion (2). The driving Pin (3) rotates with bull gear (1) and carries the sliding block (4). The sliding block slides in the slotted link (5). The slotted link is pivoted (6) at the bottom and connected to ram (7) at the top through a compensating link (8). Through this compensating link (8) lifting of the ram is arrested.

When the bull gear (1) rotates the slotted link (5) oscillates about its pivot (6) providing reciprocating motion to the ram (7).

The driving pin (3) then covers the distance A to B (angle α) during the working stroke and the distance from B to A (angle β) during the return stroke. Angle β is bigger than angle α . Therefore the working stroke takes longer time than the non-cutting stroke. This is useful because during the backward stroke no work is done.

Feed mechanism of a shaper – TR 01 16 03 01 98

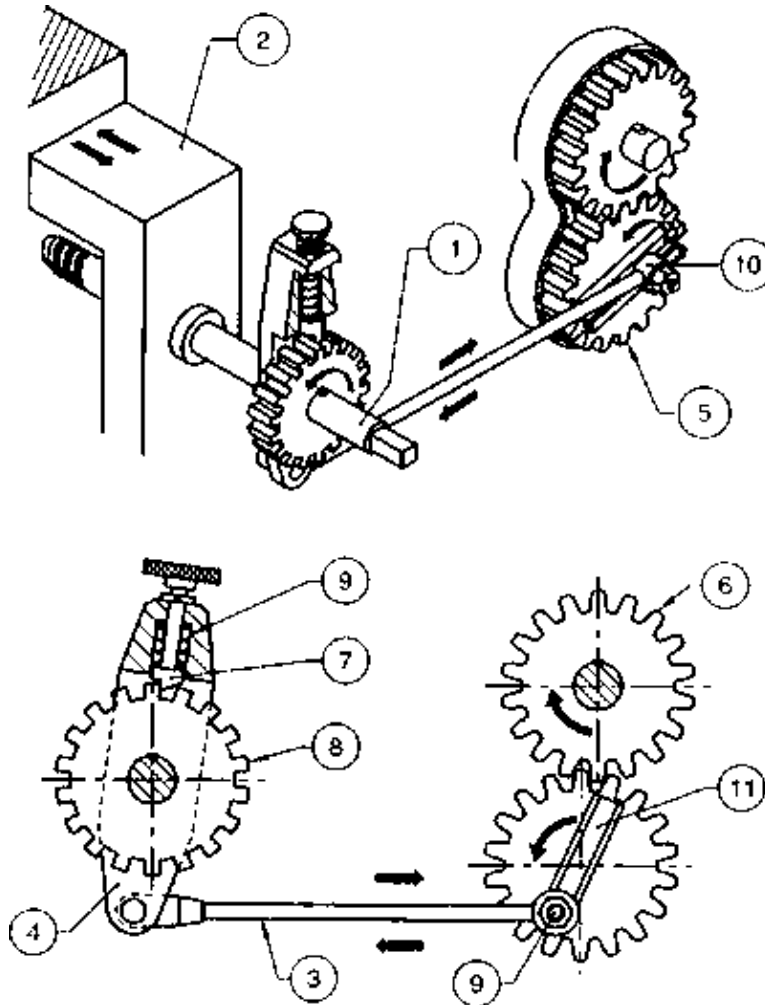

The cross feed screw rod (1) is connected with the table (2). The connecting rod (3) connects the Pawl arm (4) and the crank wheel (5).

As the crank wheel (5) rotates the Pawl arm (4) oscillates around the cross feed screw (1) to and fro. Pawl (7) is pressed on the ratchet wheel (8) by the spring (9).

The Pawl (7) which is spring loaded, is square on one side and bevelled on the other side, so that it rotates the ratchet wheel (8) as it rocks in one direction, but rides over the teeth when it rocks in the other direction. The feed can be obtained in either direction by turning the Pawl (7) through 180°.

The amount of feed can be set by shifting crank pin (9) with sliding block (10) in the crank pin slide (11).

During the manual feed, pawl (7) is pulled up and the pawl is placed in the disengaged position. Manual feed is given by rotating the cross feed screw rod (1) with a handle during the return stroke of the ram.

Hydraulic Shaper Mechanism – TR 01 16 06 01 98

Forward stroke

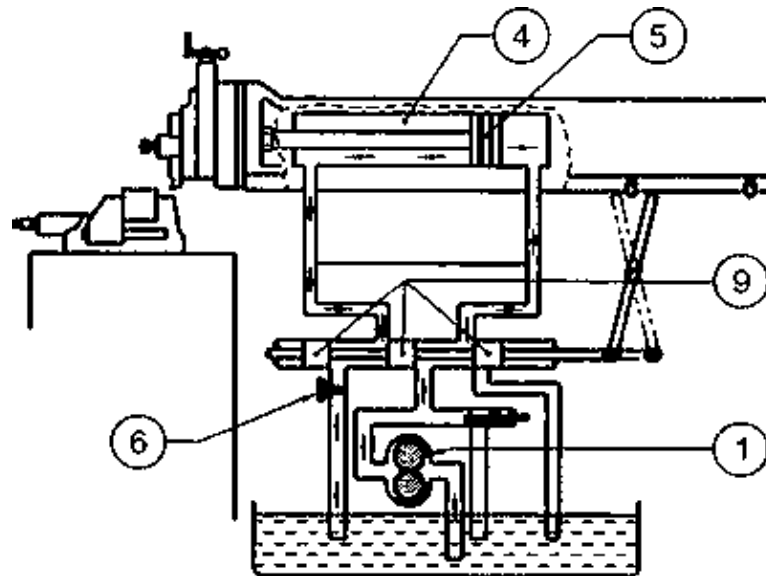

The oil under high pressure due to gear pump (1) is pumped from the reservoir (2). This oil passes through the valve chamber (3) to the right side of the cylinder (4) exerting pressure on the piston (5). This causes the ram to move in forward direction. (Forward stroke)

The oil present on the left side of the cylinder is discharged to the reservoir through the throttle valve (6).

Return stroke

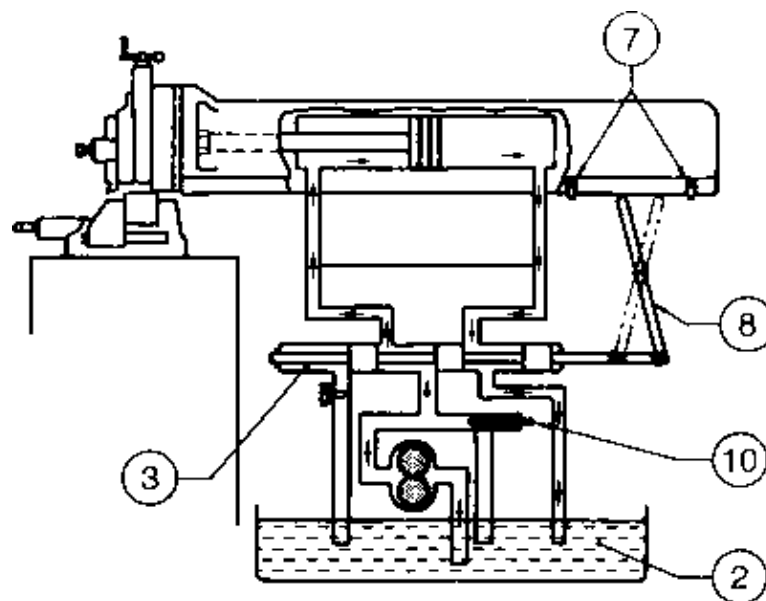

At the end of the forward stroke the reversing dog (7) hits against the reversing lever (8) causing the reversing valves (9) to alter their position within the valve chamber (3). Oil under high pressure is now made to flow to the left side of the piston causing the ram to move back (return stroke).

The oil present on the right side of the piston is now discharged to the reservoir.

This cycle is repeated.

The length and position of stroke can be adjusted by shifting the positions of reversing dogs (7).

The speed of the ram can be varied by controlling the throttle valve (6).

When the throttle valve is partially closed the excess oil flows out through the relief valve (10) to the reservoir (2) maintaining uniform pressure during cutting stroke.

Relationship of Helix angle & force acting – TR 01 19 02 01 98

Milling cutter is LEFT HAND cutting, if seen from the main drive, it runs anti-clockwise and RIGHT-HAND cutting if it runs clockwise.

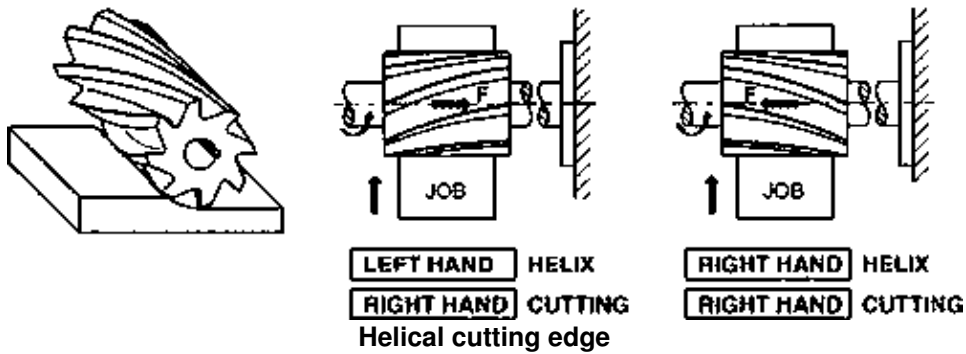

- The teeth make gradual contact
- Several teeth are always in contact simultaneously, so that the cutter runs smoothly and reduces chatter.
- The Chips flow off to the side.

Right hand helix – Left hand cutting Left hand helix – Right hand cutting

- The helix angle generates a force directed along with cutter axis during cutting and a reaction to this force in the workpiece.
- When a cutter has a helix and a cut of the same hand this force will pull the cutter away from the spindle.
- When the helix and cut are of opposite hands the force will press the cutter into the spindle.

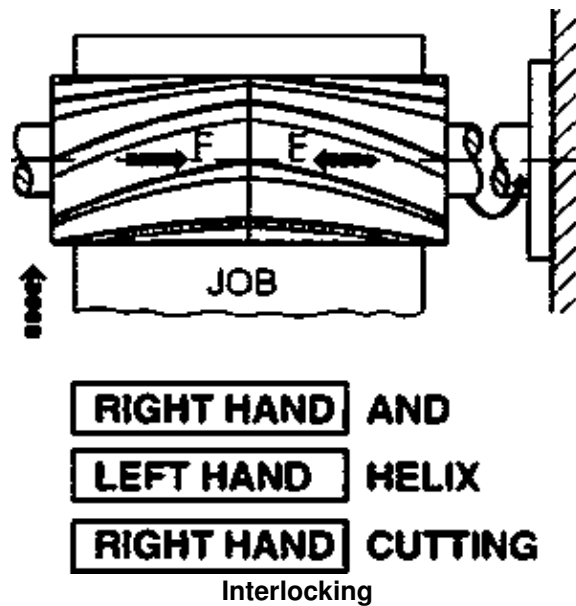

Cylindrical milling cutters with helical teeth directed against each other have the advantage that the axial pressure is partially compensated

Staggered teeth cut with alternate teeth of opposite helix and reduces the risk of chattering.

How the axial pressure is partially compensated?

One cutter has right hand helix with right hand cut. Another cutter has left hand helix with right hand cut. Hence the axial pressure is partially compensated.

Up milling and Down milling – TR 01 19 04 01 98

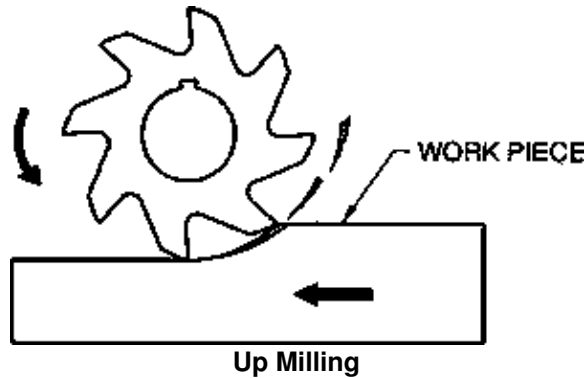

- This is commonly used method.
- Feeding of the workpiece is against the direction of rotation of the cutter.
- Cutting force is maximum at the end of the cut.
- Tool life is shorter due to scraping action of the cutter.
- The workpiece tends to get lifted.
- Used where hard surface layer to be removed.
- Very high quality surface finish is not possible.

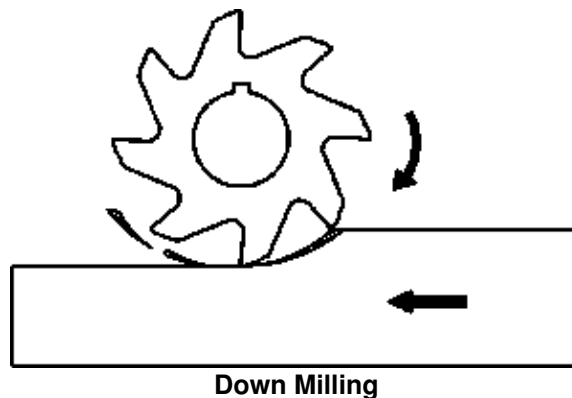

- Feeding of the workpiece is in the same direction of rotation of the cutter.
- Cutting force is heavy at the start of the cut and the cutter tends to climb.
- Play in the table screw and nut causes the table to move more than desired distance when the cutter touches job with maximum force
- Due to this
 - cutter teeth can break
 - the workpiece can be damaged
 - risk of workpiece being pulled
- Recommended only when the machine table is with a backlash eliminator.
- With backlash eliminator higher quality of surface finish is possible.

Dividing Head Parts and Functions – TR 01 19 05 01 98

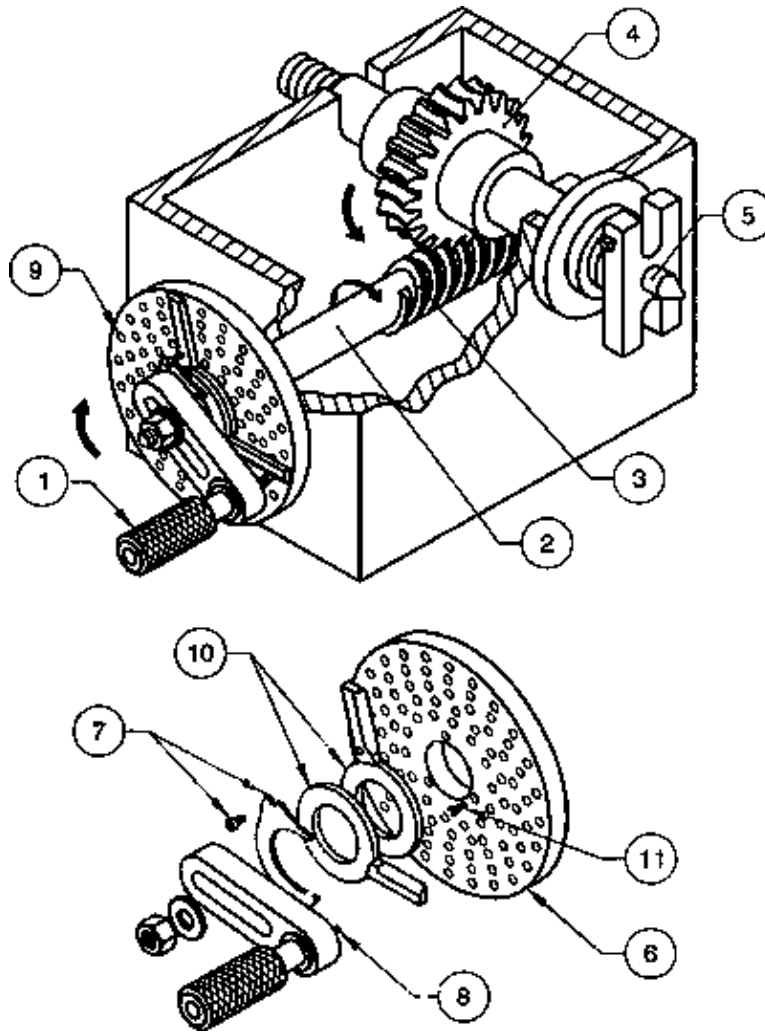

Indexing Mechanism

Dividing head is used for rotating the workpiece to any number of divisions.

The handle (1) rotates the worm shaft (2) along with the worm (3). The worm (3) is engaged with worm wheel (4). For one full rotation of worm shaft (2) the worm wheel (4) moves only by one tooth. The worm wheel (4) has 40 teeth, this makes the ratio between worm (3) and worm wheel (4) 40:1. One end of the worm wheel (4) has provision for fixing the job (5). The handle (1) for turning the worm can be adjusted towards the centre. The interchangeable index plate (6) is fixed by three screws (11) with the housing and the sector arm is connected with the index plate by a spring bolt (7). The handle (1) has plunger pin (8) by means of which the division (9) on index plate is set. The sector arms (10) save the counting of holes while indexing.

Elements of a Spur Gear I – TR 01 20 02 01 98

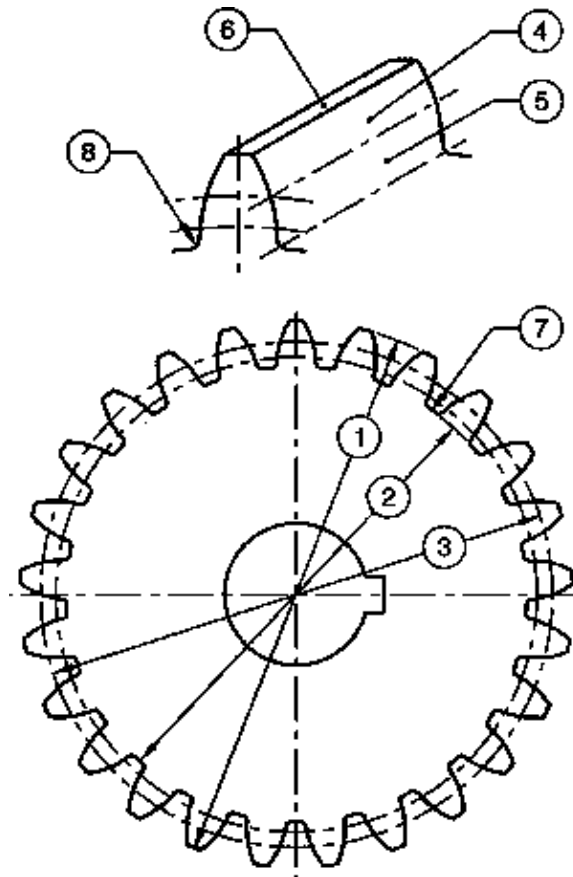

- 1 Outside diameter is the overall diameter of the gear on which the teeth are cut.
- 2 Root diameter is the diameter of the root circle.
- 3 Pitch circle diameter is the diameter of pitch circle.
- 4 Face of tooth is the surface between the pitch line element and the top of the tooth.
- 5 Flank is the surface between pitch line element and bottom of the tooth in includes the fillet.
- 6 Top Land is the surface at the top of the tooth.
- 7 Bottom Land is the surface at the bottom of the tooth space.
- 8 Fillet is the curved surface between the flank and the root surface.

Elements of a Spur Gear II – TR 01 20 02 02 98

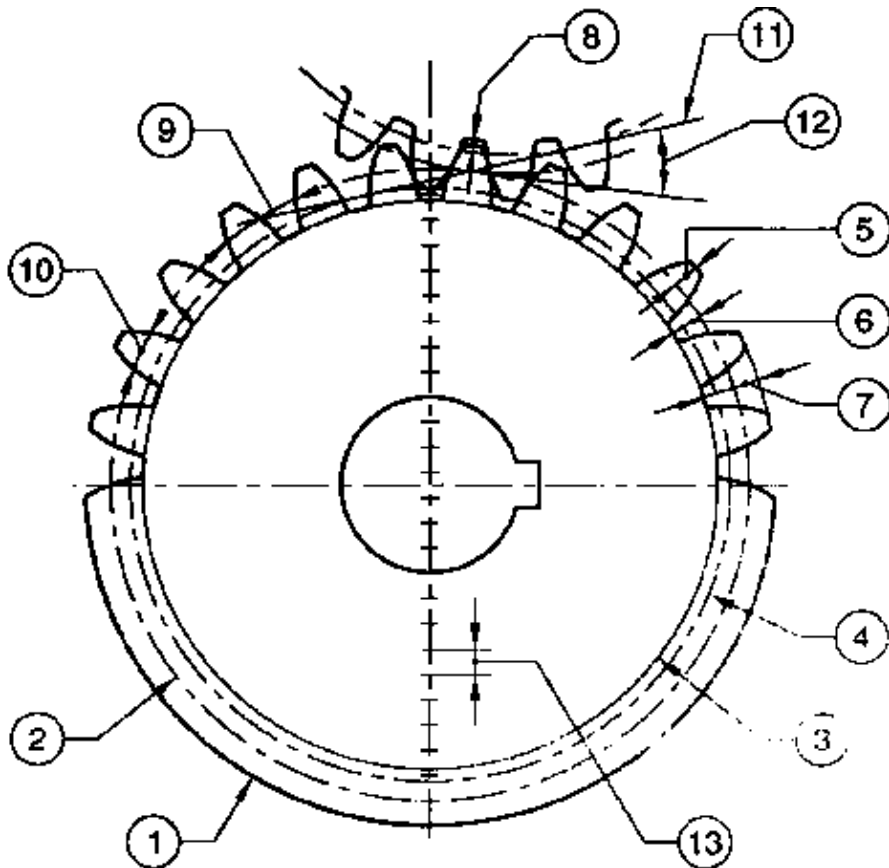

1 Outside circle is the circle formed by the top of the tooth.

2 Pitch circle is the imaginary circle of which two mating gears seems to be rolling.

3 Root circle is the circle formed by the bottoms of the tooth spaces.

4 Base circle is the circle from where the involute is generated.

5 Addendum is the radial distance between pitch circle and the outside circle.

6 Dedendum is the radial distance between pitch circle and the root circle.

7 Tooth depth/Whole depth is the total depth of the tooth ie addendum plus dedendum.

8 Clearance is the radial distance from the top of the tooth to the bottom of the tooth space in the mating gear.

9 Circular pitch is the distance from the point of one tooth to the corresponding point of the adjacent tooth measured on pitch circle.

10 Tooth thickness is the thickness of the tooth measured on the pitch circle.

11 Line of action: The common normal of two mating tooth profiles at their point of contact. Involute gear pairs, the line of action is a fixed straight line, tangent to the two base circle.

12 Pressure angle is the angle formed by a line through the point of contact of two mating teeth and tangent to the two base circles and a line at right angles to the centre line of the gears.

13 Module is defined as the ratio of the pitch circle diameter in millimetre to the number of teeth of a gear.

Gear Tooth Vernier Caliper & its Application – TR 01 20 03 01 98

Corrected Addendum

When measuring gear tooth, it is necessary to set the gear-tooth vernier caliper to the corrected addendum which is a point slightly lower than the true addendum of the gear.

If the Vernier depth slide is set to the true addendum, the caliper will measure the sides of the tooth at a point above the pitch circle and not give a true measurement.

To calculate the gear tooth vernier settings for measuring a gear of 34 teeth 2.5 module.

$$\text{Number of teeth (Z)} = 34$$

$$\text{Module (m)} = 2.5 \text{ mm}$$

$$\begin{aligned} \text{Pitch diameter (pd)} &= Z m \\ &= 34 \times 2.5 \\ &= 85 \end{aligned}$$

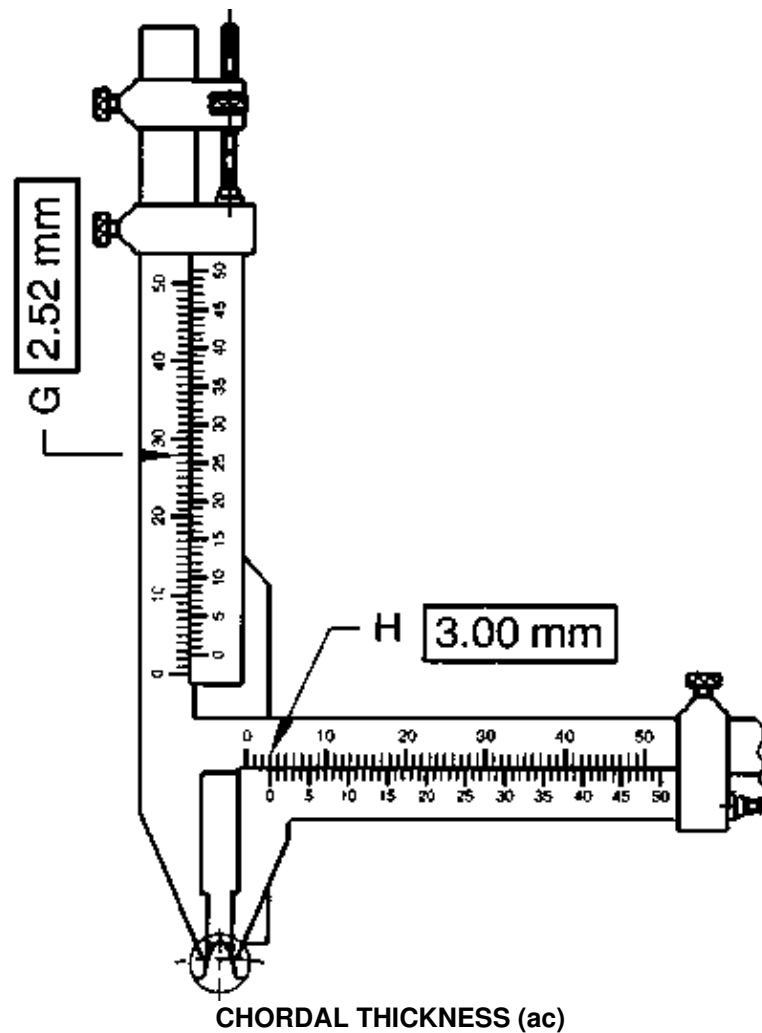

$$= mZ \cdot \sin\left(\frac{90}{Z}\right)$$

$$= 85 \cdot \sin 2.67$$

$$= 85 \times 0.0352$$

$$= \underline{2.992 \text{ mm}}$$

CORRECTED ADDENDUM (hac)

$$= m + \frac{mZ}{2} \left(1 - \cos \frac{90}{Z} \right)$$

$$= 2.5 + \frac{85}{2} (\cos 2,67)$$

$$= 2.5 + 42.5(1 - 0.9994)$$

$$= 2.5 + 42.5 \times 0.0006$$

$$= 2.5 + 0.0255$$

$$= \underline{2.52 \text{ mm}}$$

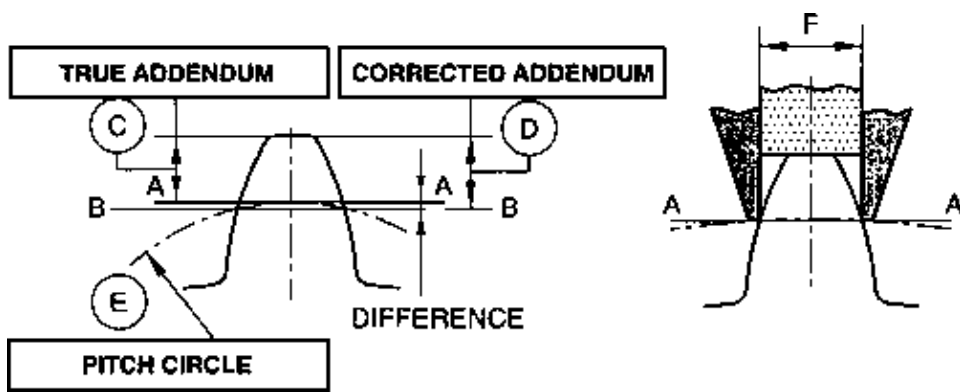

After calculating the corrected addendum and chordal thickness the gear tooth vernier is set to the calculated value and the gear tooth checked.