

- Manual Working of Material/Metal - Course: Manual working of metal. Methodical course-guide for instructors (Institut für Berufliche Entwicklung, 218 p.)**
- ➔ **Hammering and Marking**
 - 1. Objectives and contents of practical vocational training in the working techniques of "Hammering and Marking"**
 - 2. Organizational preparation**
 - (introduction...)*
 - 2.1. Preparation of instructions on labour safety**
 - 2.2. Provision of teaching aids**
 - 2.3. Provision of working tools and materials**
 - 2.4. Time schedule**
 - 3. Recommendations for practical training in the working techniques of "Hammering and Marking"**
 - (introduction...)*
 - 3.1. Introductory instruction**
 - 3.2. Exercises**
 - 3.3. Examples for recapitulation and tests**
 - 4. Application of the working techniques of "Hammering and Marking"**
 - (introduction...)*

**4.1. Instruction examples****4.2. Criteria for practical training****5. Captions and legends of the "Hammering and Marking" transparency series**

Manual Working of Material/Metal - Course: Manual working of metal. Methodical course-guide for instructors (Institut fr Berufliche Entwicklung, 218 p.)

Hammering and Marking

1. Objectives and contents of practical vocational training in the working techniques of "Hammering and Marking"

By concluding their training the trainees shall have a good command of the working techniques of "Hammering and Marking". Therefore, the following objectives are to be achieved:

Objectives

- Knowledge of the purpose and ranges of application of the hammering and marking techniques.**
- Mastery of the various working techniques of hammering and marking.**
- Capability of selecting the proper tools and accessories and of their proper use.**
- Capability of evaluating the quality of their work.**

The following contents have to be imparted to the trainees:

Contents

- Purpose of hammering and marking**
- Tools and accessories**
- Effect and working techniques of hammering**
- Working techniques of marking.**

2. Organizational preparation

To guarantee a trouble-free development of instruction, exercises and practical work it is necessary to prepare this training appropriately. The following steps have to be taken:

2.1. Preparation of instructions on labour safety

Prior to the exercises, a brief instruction in the proper use of working tools and in guaranteeing an accident-free work has to be given. The main emphasis is to be laid on:

Use of flawless hammers with well-fixed handles only.

Selection of the proper (hard and inflexible) support for hammering.

Use of burr-free punches.

Precautions for preventing fire damage in case of annealing the steel sheets.

Familiarity with these hints is to be confirmed by the trainees' signatures in a

control book.

2.2. Provision of teaching aids

For demonstration purposes during instruction, a vice and appropriate hammering supports have to be installed at the place.

The "Trainees' Handbook of Lessons - Hammering and Marking" has to be handed out to the trainees, when using the transparencies series of "Hammering and Marking", check whether it is complete (transparencies 3.1. - 3.4.) and whether the overhead projector is functional. (Check the operating conditions at the place of use and make sure of the proper mains supply!)

Surveys which are to be written on the blackboard have to be completed prior to instruction.

All the tools and accessories mentioned in section 3 (for hammering and marking operations) should be kept ready for illustration purposes.

2.3. Provision of working tools and materials

The "Instruction Examples for Practical Vocational Training

- Hammering and Marking" must be handed out to the trainees in sufficient copies to provide them with the theoretical foundations for the exercises to be performed.

The initial materials necessary for the exercises are to be prepared and laid out in

sufficient numbers according to the specifications of the “Instruction Examples...”.

Each trainee is to be provided with a workbench that is equipped with a flat hammering support and a firmly installed vice (check whether it has the appropriate working height).

It must be checked that all workbenches are fully equipped with tools and accessories specified for the planned exercises. Recommended basic equipment:

- steel rule, vernier caliper, protractor**
- steel scriber, centre punch, dividers**
- hand hacksaw or hand-lever shear**
- bastard and smooth files 200 mm (flat)**
- locksmith’s hammer (engineers’ hammer) chasing hammer, curving hammer, wooden hammer**
- sledge, bordering tool, marking punch (numbers and letters)**
- surface plate or anvil, clamping devices.**

2.4. Time schedule

Time planning is recommended for the following training stages:

- introduction to the working techniques by way of instruction**
- necessary demonstrations**
- job-related instructions for carrying out the exercises**
- carrying out the exercises, recapitulation and tests.**

The necessary time share depends on the respective training conditions. Most of

the time is to be allocated to the exercises

3. Recommendations for practical training in the working techniques of "Hammering and Marking"

The following paragraphs comprise proposals on conducting trainee instruction, carrying out demonstrations of working techniques as well as exercises and tests. We recommend two course variants:

Variant No. 1.

This variant should be chosen for trainees with generally good achievements and receptiveness.

1.1. Introductory instruction to the whole subject, accompanied by demonstrations specified in the "Trainees' Handbook of Lessons"

1.2. Exercises in hammering and marking as well as subsequent evaluation as specified in the "Instruction Examples 3.1. -3.7."

1.3. Test of theory knowledge based on the contents of "Examples for Recapitulation and Tests".

Variant No. 2.

This variant should be chosen for trainees with little previous knowledge or poor achievements.

2.1. Introductory instruction for the subjects of “Lengthening (elongating) and curving”, accompanied by demonstrations specified in the “Trainees’ Handbook of Lessons”.

2.2. Exercises in lengthening and curving as specified in the “Instruction Examples 3.1. - 3.4.” and subsequent evaluation.

2.3. Supplementary instruction in the subject of “Chasing and flanging (bordering)” as specified in the “Trainees’ Handbook of Lessons”.

2.4. Exercises in chasing and flanging as well as evaluation, as specified in the “Instruction Example 3.5.”.

2.5. Supplementary instruction in the subject of “Marking” as specified in the “Trainees’ Handbook of Lessons”.

2.6. Exercises in marking, with subsequent evaluation as specified in the “Instruction Examples 3.6. and 3.7.”.

2.7. Final test of theory knowledge as specified in the “Examples for Recapitulation and Tests”.

The evaluation of practical skills should be done immediately after handing over the finished workpiece to the instructor. Knowledge of theory can be permanently checked, but it is advisable to have a final test paper (item 1.3. or, resp., 2.7.) after concluding the exercise.

3.1. Introductory instruction

If possible, this instruction should be given in a classroom.

Make sure that the trainees put down necessary, supplementary hints or answers to questions in their “Trainees’ Handbook of Lessons”.

Instruction may be conducted on the basis of the main points contained in the “Trainees’ Handbook of Lessons”.

The main subjects of “purpose of hammering and marking” as well as “tools and accessories for hammering” should be accompanied by an intensive employment of all those teaching aids available.

Purpose of hammering and marking

To demonstrate the purpose of these working techniques, it is advisable to show such workpieces which had been formed, straightened or, resp., marked by figures and letters. The instructor has to point out that this is mainly used in single-piece production. A summary can be given by using the “Trainees’ Handbook of Lessons” as a guideline.

Tools and accessories

Transparency No. 3.1. can supplement the demonstration of original tools and accessories.

When describing the individual tools and accessories, their intended purpose has to be pointed out.

The following tools have to be shown and introduced:

- **locksmith's hammers (hand hammer, riveting hammer, bench hammer)**
- **hammers for sheet metal working (chasing, curving, finishing and planishing (or smoothing) hammers as well as wooden, rubber and aluminium hammers).**

Following this instruction, the trainees should be in a position to describe the intended purpose of these hammers and to use their correct designations (using size and shape of hammers as distinctive marks).

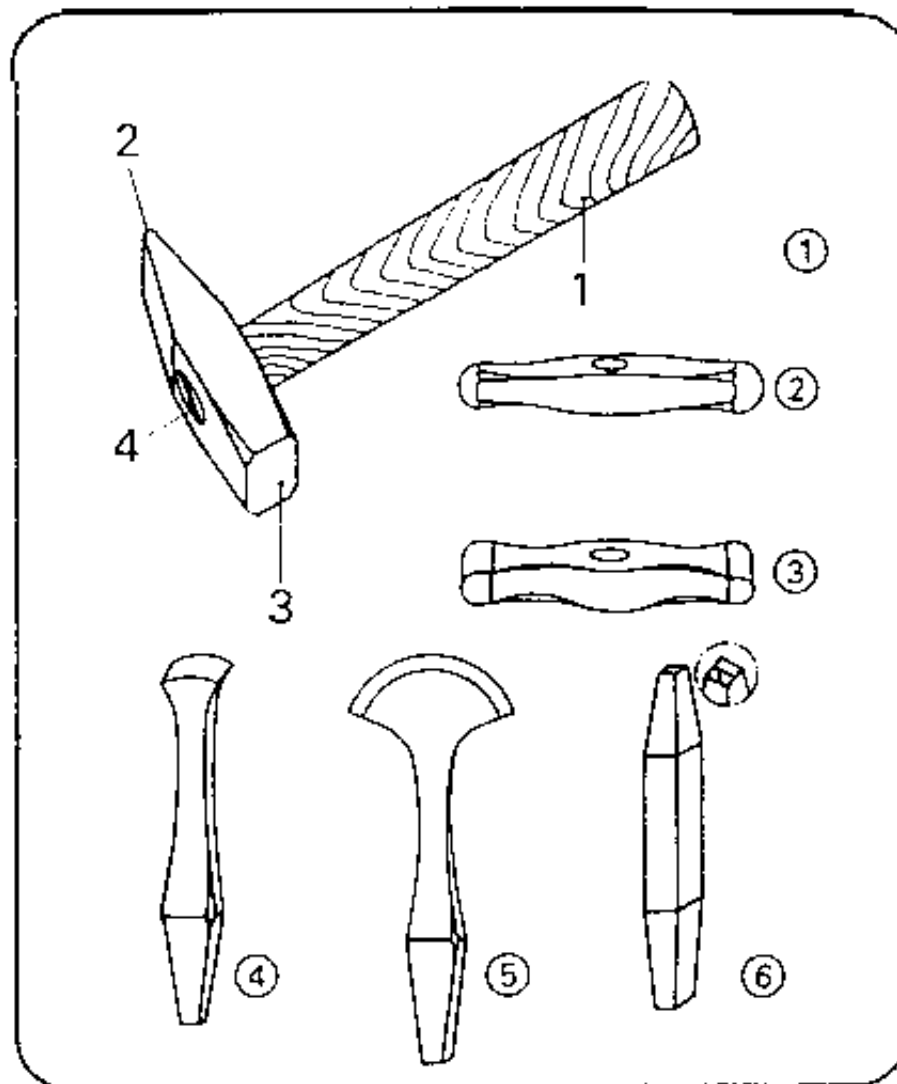

Figure 3.1

This is followed by remarks on hammering supports:

- surface plate**
- blacksmith's anvil**

- special supports for sheet metal working (anvil tool, sledge, blacksmiths' hardy and bordering tool).

The intended purpose of using these supports is to be made quite clear.

The following marking tools should be included in the demonstrations:

- sets of letters (in an alphabetical order)**
- sets of numbers**
- punches with special numbers or words.**

If not all of these tools and accessories are available as originals, the illustrations contained in the "Trainees' Handbook of Lessons" may be employed.

Effect of Hammering

The effects of hammering should be demonstrated by some examples A narrow strip of sheet metal should be worked with the face of a hammer and with the pane of a hammer. Thus, the trainees will learn that the processes of lengthening and upsetting will be influenced by the form of the hitting area of the tool as well as by the form of the hammering support. The trainee has to learn the technique of hardening the material by cold working, i.e. by many blows of the hammer. Annealing and the various types of cooling down depending on the kind of material should be mentioned in these instructions. The trainees should be shown how to position the hammer when performing the blows. It is recommended that each trainee does some blows with a hammer, so that mistakes can be corrected immediately. Following this, the trainees should answer the questions contained in the "Trainees' Handbook of Lessons" in writing.

Working techniques of hammering

The various working techniques should be taught in the following order:

Lengthening

The trainees can be shown the hammering technique of using the face or pane of a hammer once again.

The trainees will understand that blows with the pane will lengthen the material, whereas the face will lengthen and widen the material.

Transparency No. 3.2. can illustrate this process.

Curving

The trainees have to be shown the use of the pane of a locksmith's hammer or the faces of a curving hammer.

When demonstrating this working technique, emphasis is to be laid on evenly distributed hammer blows - the strip of sheet metal must show an arch-like curvature.

Transparency No. 3.3. will help to make this and the following working techniques clear.

Chasing

Two possible variants have to be demonstrated.

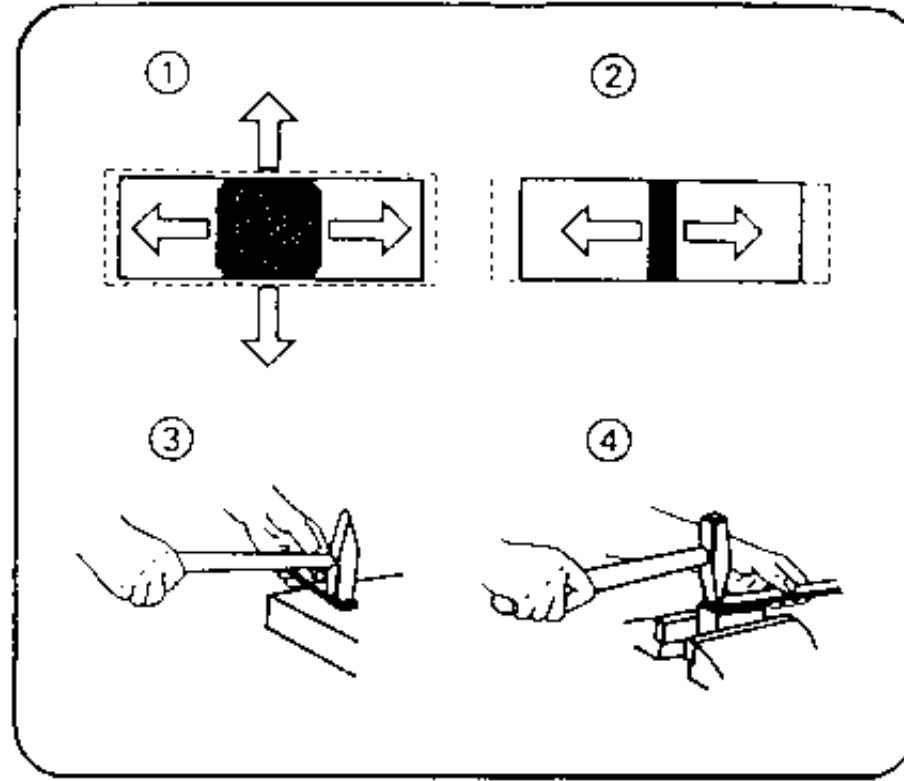

Figure 3.2

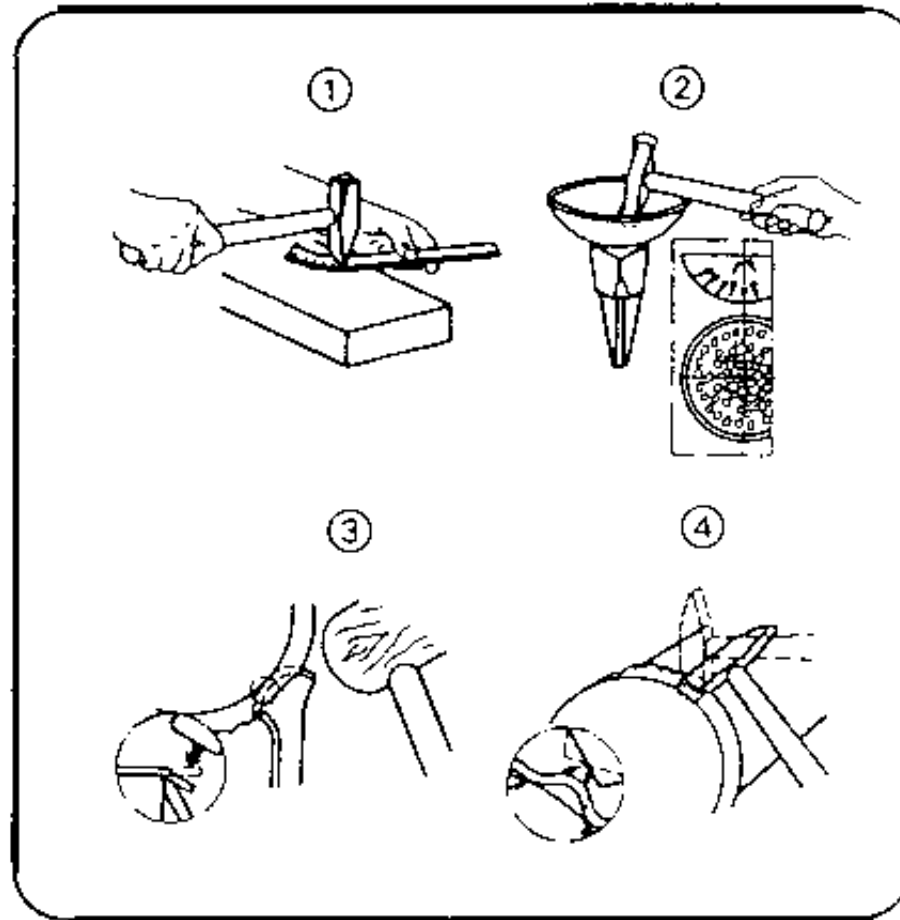

Figure 3.3

Variant No. 1

When using the face of a chasing hammer on a flat support, the instructor has to show that the hammer blows begin at the centre of the workpiece and then follow a spiral-like pattern to the outside of the workpiece.

Variant No. 2

When chasing with a rounded wooden hammer or chasing hammer on a hollow support, the instructor has to show that the hammer blows begin at the outside and advance to the centre in a spiral-like pattern.

This is followed by referring to the process of hardening by cold working again. The trainees have to learn that cracks will occur in the sheet metal, if this fact is neglected. Later on the trainees are shown the appropriate forms of annealing and cooling down in a workshop.

Flanging

The various techniques of outside and inside flanging can be explained in combination with the figures in the "Trainees' Handbook of Lessons".

It should be emphasised that this working technique is divided into two stages: rough-flanging and finish-flanging.

The use of various types of hammers (locksmith's hammer, bevelled wooden hammer, chasing hammer, curving hammer) has to be mentioned at the appropriate place.

Working technique of marking

When imparting the knowledge of placing and blowing the marking punch to the trainees, they have to be informed on the necessary preparation by appropriately scribed lines. The interdependence of height of letters and space between the lines should be demonstrated briefly. This demonstration can refer to the following table and its recommended values:

space between the lines	height of figures or letters
3	2.5
5	4
8	6
10	8
12	10

A small piece of sheet metal may serve to demonstrate the working technique of scribing using a marking gauge. The following hints should be included in the instruction on marking punches:

- The head of the punch must be burr-free.**
- The engraving of a figure or letter must be perfect.**
- The marking punch must not be crooked.**

The trainees have to learn that marking operations require a high degree of concentration. This makes it necessary for the order of figures and letters during the marking operation to be permanently monitored.

Transparency No. 3.4. can be used to further illustrate this fact.

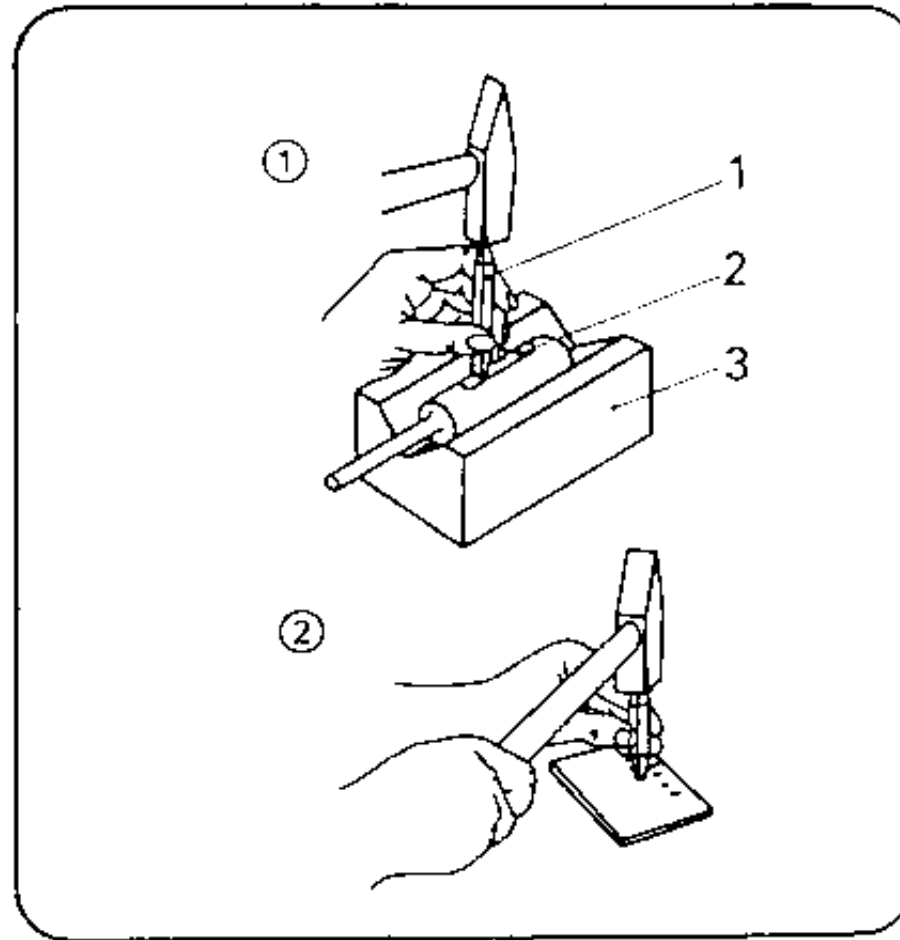

Figure 3.4

3.2. Exercises

If it was not possible to include demonstrations in the instruction, this must be done prior to the start of the exercises. If the trainees avail of only little practical skills, they should perform preliminary exercises on any small-size workpieces:

- minor exercises in lengthening sheet metal strips

- **curving of a simple arch**
- **marking a combination of figures.**

However, it is also possible to begin with the first exercise specified in the “Instruction Examples for Practical Training”, at once.

However, it will be necessary, to prepare each exercise by a brief “job-related instruction”, in which the trainees are shown a finished workpiece in order to make the purpose and intention of the exercises quite clear.

The instructor must have finished such a workpiece by himself, so that he knows the problems involved in producing such a workpiece.

This makes it possible to identify the main points in evaluating the trainees' work and to inform them about difficult areas on the workpiece. During this special instruction, the sequences of operations and working drawings should be on the desks so that the trainees can make notes therein. All the trainees can carry out the exercises simultaneously, if the appropriate number of working tools is available. If this is not possible, the trainees will be divided into groups according to the various categories of work and number of the tools available. Trainees who cannot start with hammering and marking operations should perform some other activities in the workshop: selection and preparation of initial materials, checking and minor repair work on working tools under the supervision of the instructor. It is also possible to carry out exercises which consolidate the skills and knowledge of previously learned working techniques.

3.3. Examples for recapitulation and tests

This section comprises questions which should help to consolidate and test the acquired knowledge and skills. Each question is provided with the respective answer. Questions which are also contained in the "Trainees' Handbook of Lessons" are marked with the letter "A".

1. What is the purpose of hammering?

(Working of sheet and sectional metal by carefully directed blows of a hammer for forming, straightening, strengthening or hardening the workpieces.)

2. What is the purpose of marking?

(Punching of figures and letters into the surfaces of workpieces in order to distinguish them from each other or to indicate the order of assembling or to mark necessary manufacturing data in a long-lasting manner.)

3. How do the design types of locksmith's hammer and hammers for sheet metal working differ?

"A" (Locksmith's hammers differ from one another by their weight and size, but their heads show a uniform shape. Hammers for sheet metal working have, apart from differing weights, a differing form of faces and they have no panes.)

4. What are the required properties of hammering supports?

"A" (Rigid, inflexible, possibly hardened - smooth surface.)

5. Which hammering supports are meeting the general requirements of hammering?

"A" (Surface plate, blacksmith's anvil.)

6. Which hammering supports meet the special requirements of sheet metal

working?

(Anvil tool, sledge, blacksmiths' hardy and bordering tool,)

7. What types of marking punches are generally used?

"A" (Letter punches and figure punches.)

8. What is the typical effect of hammering?

"A" (The impact of the hitting hammer head upsets the material which has to give way laterally. The hammering support prevents a displacement into the direction of the blow.)

9. What property must materials have that shall be hammered?

"A" (They must be ductile.)

10. What is the effect of many hammer blows on a single spot of a workpiece?

"A" (The material consolidates and gets hard and brittle.)

11. How can this effect be reduced or eliminated?

"A" (Annealing or cooling down.)

12. Which difference do we have to consider in working steel sheets and in working copper sheets with this technique?

(Steel sheets have to be cooled down slowly, copper sheets have to be cooled down fast.)

13. What makes the difference in lengthening and curving of a metal strip?

"A" (Lengthening will elongate the metal strip in a straight line or widen it at the same time; curving will lengthen the metal strip unilaterally and bend it arch-like

on the plane.)

14. How must the blows be directed when lengthening and curving?

"A" (Short, successive blows from front to rear or from rear to front.)

15. Which variants of blows are possible in chasing sheet metal?

(Variant 1: The blows of the hammer will be performed spirally on a flat hammering support - beginning inside and ending outside.

Variant 2: The blows of the hammer will be performed spirally on a hollow hammering support - beginning outside and ending inside.)

16. What are the working steps of flanging borders of sheet metal?

"A" (Rough-flanging - bending down of the border of the metal sheet finish-flanging - bulging-in of the wrinkles and smoothing of the border.)

17. Which hammering supports should be used when flanging lids or covering caps of containers?

(The container to be covered should serve as a hammering support.)

18. How must we scribe the lines necessary for marking combinations of figures or letters?

(With pencil or brass scriber - the spacing must slightly exceed the height of the figures or letters.)

19. What must be done first, if the marking has to be performed on rough or curved surfaces?

(The sections of the surfaces to be marked have to be smoothed or levelled first.)

4. Application of the working techniques of “Hammering and Marking”

The sequence of exercises can focus on one topic each according to the variant mentioned in section 3 or it may be divided into several stages.

The “Instruction Examples for Practical Vocational Training -Hammering and Marking” provide 7 exercises whose degree of difficulty increases gradually.

These “Instruction Examples...” comprise a list of required materials (initial material, hand tools, measuring and testing tools, accessories), as well as the sequence of operations for producing the workpiece. An illustrative working drawing is also contained in these “Instruction Examples...”. Thus, the trainees avail of the required information to do their exercises in an objective-related way. If the progress of work during the exercises shows that the achieved quality standards of the workpieces is not sufficient, the trainees must carry out comprehensive preliminary exercises. In this case it is possible to use any appropriate waste components. If the skill has been practised sufficiently, the workpiece mentioned in the “Instruction Examples...” can be manufactured. Please, take the following hint into consideration:

From the very beginning (i. e. cutting to size) until finishing the workpiece, the trainee has to do all the associated work by himself. This is the only way to guarantee a just evaluation of his achievement.

If the “Instruction Examples...” offered in this material should not be used for exercise purposes, it will be possible to work on other workpieces. However, you have to see to it that all the previous working techniques will be practised with

that exercise.

4.1. Instruction examples

To give a survey of the workpieces on which the previous knowledge shall be practised, the individual instruction examples are described in brief here:

Instruction Example 3.1.

Nameplate

A narrow strip of sheet steel is lengthened with the pane of a hammer so that it becomes 10 mm longer.

Action of the surface is smoothed with a hammer and sledge and then the trainee's name is marked on it.

This plate may be fixed to the finished workpieces so that it is easier to identify them.

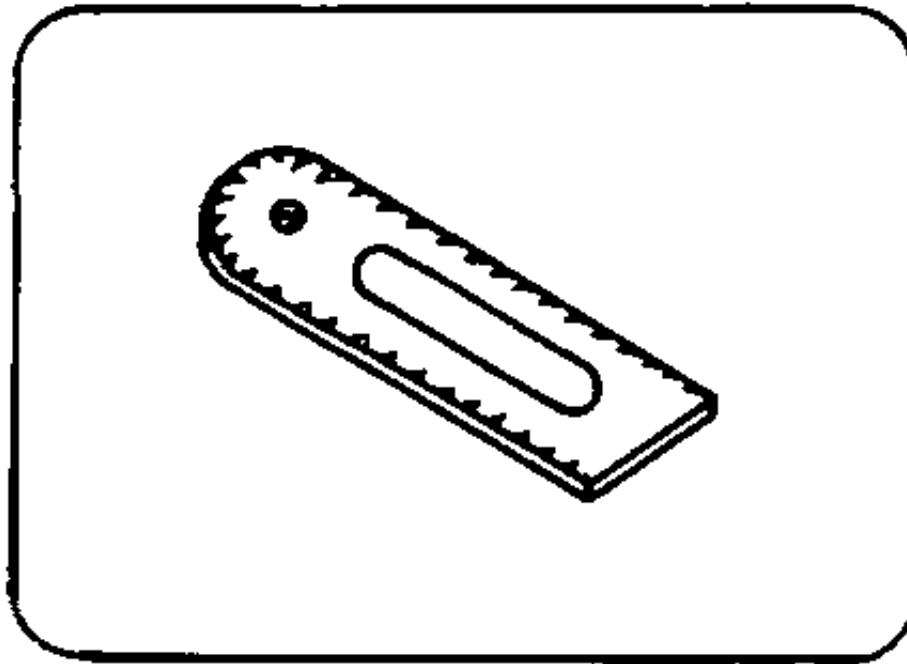

Figure

Instruction Example 3.2.

Number Plate for Locker

A narrow strip of sheet steel is curved with the pane of a hammer according to specified dimensions. After smoothing a section of the surface and marking it with a figure it can be used as a numberplate for tool cabinets and wardrobes.

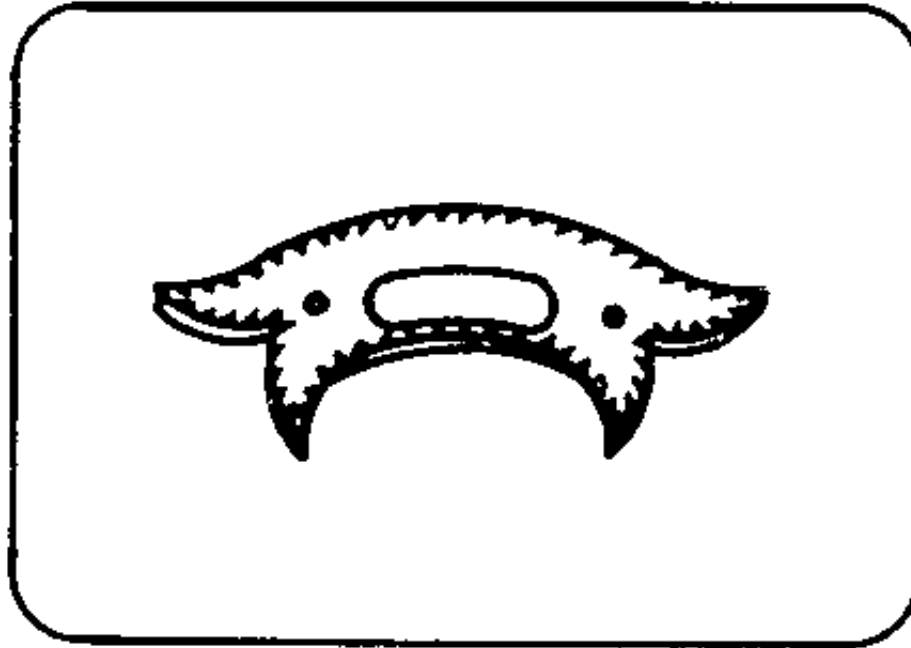

Figure

Instruction Example 3.3.

Screw driver

The face of a hammer is used to flatten round bar steel so that a screw driver blade and a handle extension will be produced. This workpiece can be finished by filing or grinding it according to Instruction Example 12.3.

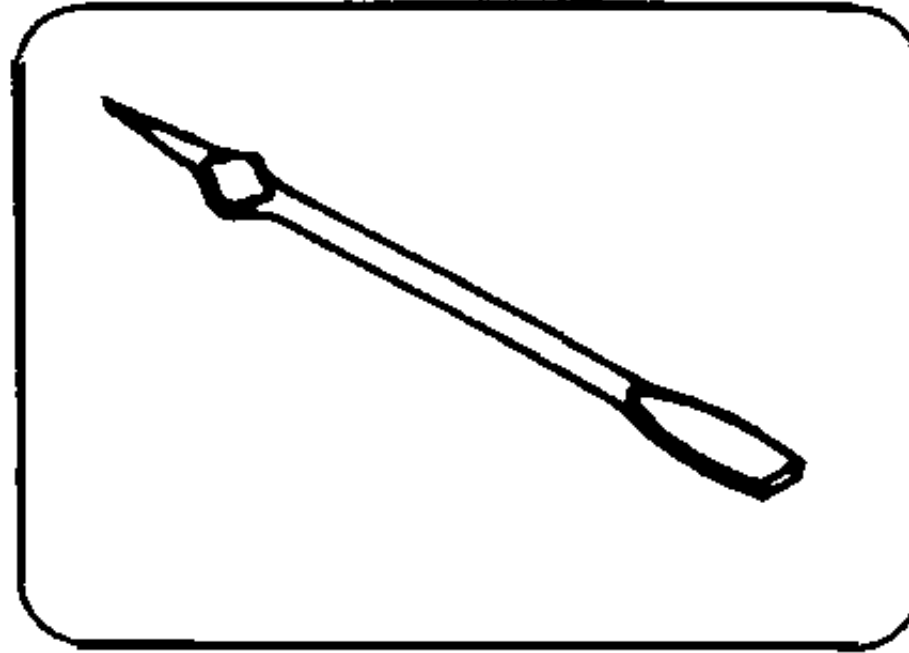

Figure

Instruction Example 3.4.

Copper Bit of a Soldering Iron

Round bar copper material is flattened with the face of the hammer and then work-hardened. After its completion this workpiece can be used in the workshop.

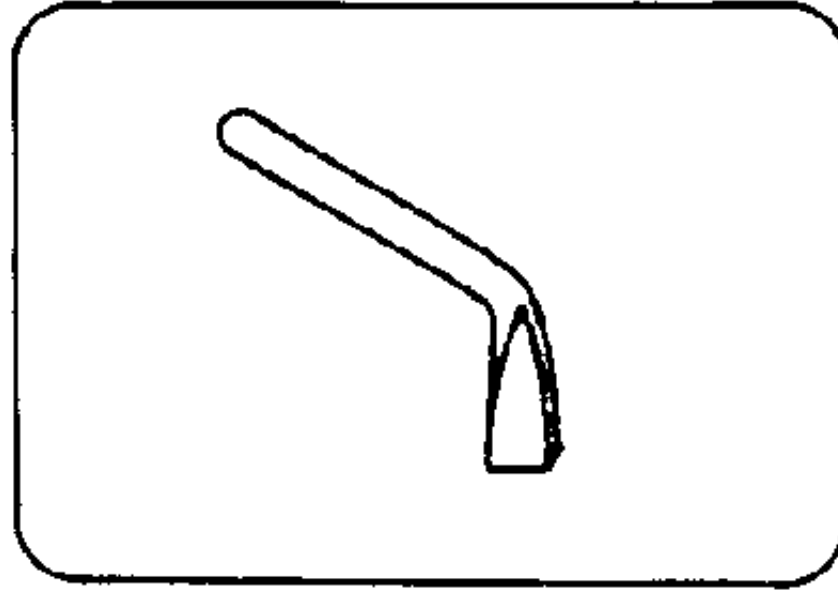

Figure

Instruction Example 3.5.

Bowl with Cover

Placed upon a hollow hammering support (steel tube), thin copper sheets are chased to form a bowl; a second sheet will be flanged so that it forms a cover matching the bowl.

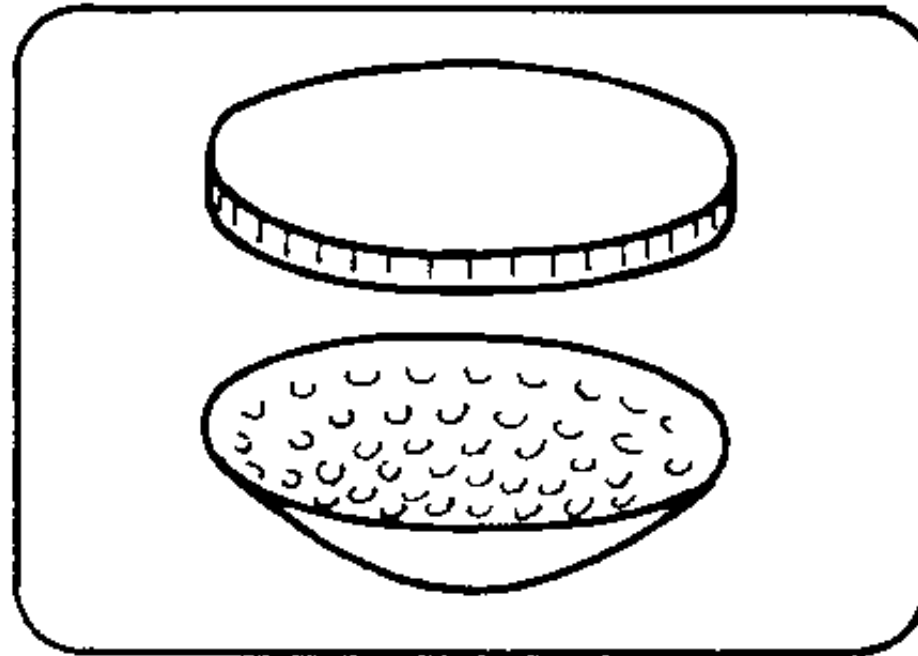

Figure

Instruction Example 3.6.

Table to Determine Tapping Drill Holes and Bore Depths

A table is punch-marked into a small-size steel sheet. When applying the working technique of “Thread Cutting” it will serve as a means to determine the required values.

Such a table is very handy and can be added to the personal tools of the trainee.

N	D	T
M5	4,2	3,6
M6	5,0	4,5

Figure

Instruction Example 3.7.

Table to Determine Widths across Flats and Widths across Corners of Hexagon-Head Screws and Nuts

A table will be punch-marked into a small-size steel sheet. In the assembly of screwed connections these values are required. They serve to select the proper open-ended spanners for the hexagon-head screws and nuts. This table is handy and can be added to the personal tools of the trainee.

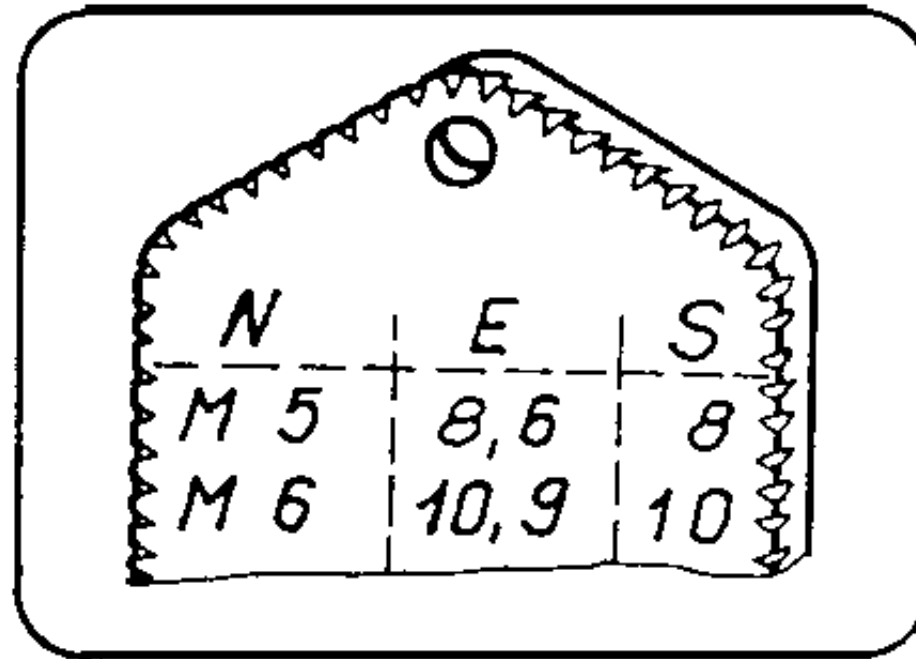

Figure

4.2. Criteria for practical training

It is recommended to determine some major points of observation and evaluation when the work is being carried out. The following criteria may serve as a guideline:

Lengthening

Is the sequence of blows of the hammer uniform and narrowly spaced from one side to the other or does the trainee strike here and there at random?

Does the metal sheet stay straight during lengthening or does it curve?

Curving

Is the curvature of the sheet even or are there waves?

Chasing

Do the blows of the hammer comply with the respective variant (according to the hammering support)? Does the trainee take cold-hardening into consideration and are there the proper intervals for cooling down the sheet?

Are there any cracks resulting from chasing? Is it an even curvature or are there any buckles?

Flanging

Does the trainee observe the two working stages of rough-flanging and finish-flanging?

Does the trainee employ the appropriate types of hammers?

Is it an even flanging or are there any waves and irregularities?

Marking

Are the lines scribed with proper spacings?

Is the position of figures or letters even and upright?

Is there an even depth of punching?

Can the figures or letters be clearly identified or are there any double punchings?

5. Captions and legends of the “Hammering and Marking” transparency series

Transparency No. Selected Tools for Hammering and Marking
3.1.

- (1) Locksmith’s hammer
 - 1 wooden handle
 - 2 pane
 - 3 face
 - 4 wedge
- (2) chasing hammer
- (3) curving hammer
- (4) bordering tool (flanging tool)
- (5) blacksmiths’ hardy
- (6) marking punch

Transparency No. Flattening (widening) and Lengthening with Locksmith’s Hammers
3.2.

- (1) Effect of hammer face
- (2) effect of hammer pane
- (3) flattening and lengthening with hammer face
- (4) lengthening with hammer pane

Transparency No. Curving, Chasing, Flanging
3.3.

- (1) curving with pane of locksmith’s hammer

(1) curving with plane or locksmith's hammer

(2) chasing of a bowl with chasing hammer

(3) flanging of metal sheet border with blacksmiths' hardy and wooden hammer

(4) bulging-in of wrinkles with locksmith's hammer

Transparency No.
3.4.

Marking with marking punches

(1) marking on curved surfaces

1 marking punch

2 filed area

3 vee support

(2) marking of combinations of figures -at right angles to the line of sight



[Home](#) > [ar](#).[cn](#).[de](#).[en](#).[es](#).[fr](#).[id](#).[it](#).[ph](#).[po](#).[ru](#).[sw](#)

 **Manual Working of Material/Metal - Course: Manual working of metal. Methodical course-guide for instructors (Institut fr Berufliche Entwicklung, 218 p.)**

  **Manual Sawing**

 **1. Objectives and contents of practical vocational training in the working technique of "Manual Sawing"**



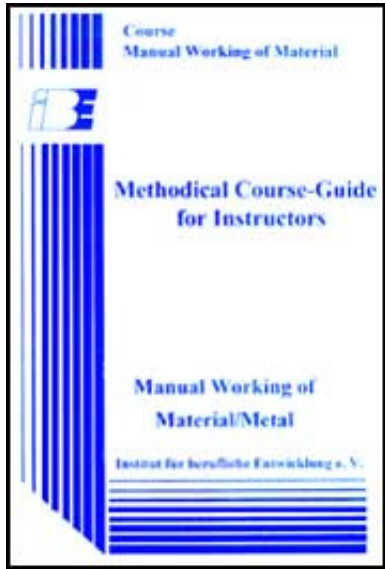

0. Organizational preparation (*introduction...*)

2.1. Preparation of instructions on labour safety

2.2. Provision of teaching aids

2.3. Provision of working tools and materials

2.4. Time schedule

3. Recommendations for practical vocational training in the working technique of "Manual Sawing"

(*introduction...*)

3.1. Introductory instruction

3.2. Exercises

3.3. Examples for recapitulation and tests

4. Application of the working technique of "Manual Sawing"

(*introduction...*)

4.1. Instruction examples

4.2. Criteria for practical training

5. Captions and legends of the "Manual Sawing" transparencies series

Manual Working of Material/Metal - Course: Manual working of metal. Methodical course-guide for instructors (Institut für Berufliche Entwicklung, 218 p.)

Manual Sawing

1. Objectives and contents of practical vocational training in the working technique of "Manual Sawing"

By concluding their training the trainees shall have a good command of the working technique of "Manual Sawing". Therefore, the following objectives are to be achieved:

Objectives

- Knowledge of the purpose and application of manual sawing.**
- Mastery in handling the saw and capability of carrying out true-to-size sawing cuts of any kind.**
- Capability of selecting the proper tools and accessories and their proper use.**
- Capability of evaluating the quality of their own work.**

The following contents have to be imparted to the trainees:

Contents

- Purpose of sawing**
- Tools and accessories**
- Effects of sawing and handling of saws**

2. Organizational preparation

To guarantee a trouble-free development of instructions, exercises and practical work it is necessary to prepare this training properly.

The following steps have to be taken:

2.1. Preparation of instructions on labour safety

Prior to the exercises a brief instruction on the proper use of tools and materials has to be given. This comprises hints for accident-free work.

The main emphasis is to be laid on:

- Hand hacksaws with crackless handles must be used only**
- Fixing components must not protrude at the side of the clamp dog!**
- The guide hand must not work in the range above the vice!**

Familiarity with these hints is to be confirmed by the trainee's signature in a control book.

2.2. Provision of teaching aids

For demonstration purposes during instruction, a vice has to be installed at the place.

The "Trainees' Handbook of Lessons - Manual Sawing" is to be handed out to the trainees.

When using the transparencies series of "Manual Sawing", check whether they are complete (transparencies nos. 4.1. - 4.3.) and whether the overhead projector is functional. (Check the operating conditions at the place of use and make sure of the proper mains supply!)

Surveys which are to be written on the blackboard have to be completed prior to instruction.

All the tools and accessories mentioned in section 3 (for sawing purposes) should be kept ready for demonstration.

2.3. Provision of working tools and materials

The “Instruction Examples for Practical Vocational Training -Manual Sawing” must be handed out to the trainees in sufficient copies to provide them with the theoretical foundations for the exercises to be performed.

The initial materials necessary for the exercises have to be laid out and prepared in sufficient numbers of copies according to the specifications mentioned in the “Instruction Examples...”.

Each trainee is to be provided with a workbench with a stationary vice (check the proper working height of the vice).

The trainees’ workbenches have to be fully equipped with tools and accessories according to the exercises planned. Do not forget to check this! Recommended basic equipment:

- steel rule, try square, protractor**
- steel scriber, prick-punch, dividers**
- locksmith’s hammer**
- hand hacksaw with various types of saw blades**
- bastard and smooth files - 200 mm and 250 mm (flat and half round)**

- vee clamps.

2.4. Time schedule

Time planning is recommended for the following training stages:

- introduction to the working technique in the form of instructions**
- necessary demonstrations**
- job-related instructions in performing the exercises**
- performing the exercises**
- recapitulation and tests.**

The necessary time share depends on the respective training conditions. Most of the time is to be allocated to the exercises

3. Recommendations for practical vocational training in the working technique of "Manual Sawing"

The following paragraphs comprise proposals on conducting trainee instruction, the demonstration of the working techniques as well as exercises and tests. We recommend the following way of conducting the course:

Introductory instruction with demonstrations from the "Trainees' Handbook of Lessons".

Exercises in sawing from "Instruction Examples 4.1. - 4.6." and subsequent evaluation.

Final test of theory knowledge based on the contents of the

“Examples for Recapitulation and Tests”.

The exercise associated with “Instruction Example 4.7.” can follow later as a complex work, because it is necessary to acquire other working techniques first.

Practical skills should be tested immediately after handing over the finished workpiece. Knowledge of theory should be constantly checked. However, it is recommended that a final test paper should be written after the conclusion of the exercises.

3.1. Introductory instruction

If possible, this instruction should be given in a classroom. Make sure that the trainees put down necessary supplementary hints or answers to questions in their “Trainees’ Handbook of Lessons”.

Instruction can be carried out on the basis of the main points contained in the “Trainees’ Handbook of Lessons”. The main subjects of “Purpose of Sawing” and “Tools and Accessories for Sawing” are to be taught with the employment of all the teaching aids available.

Purpose of sawing

This subject should be illustrated by presenting workpieces which were cut by sawing or which show kerfs. The trainees should recognize the single-piece nature of this work.

Tools and accessories

Transparencies nos. 4.1. and 4.2. can support the demonstration of original tools and accessories. The design of a hand hacksaw and the fixing of the saw blade is to be explained.

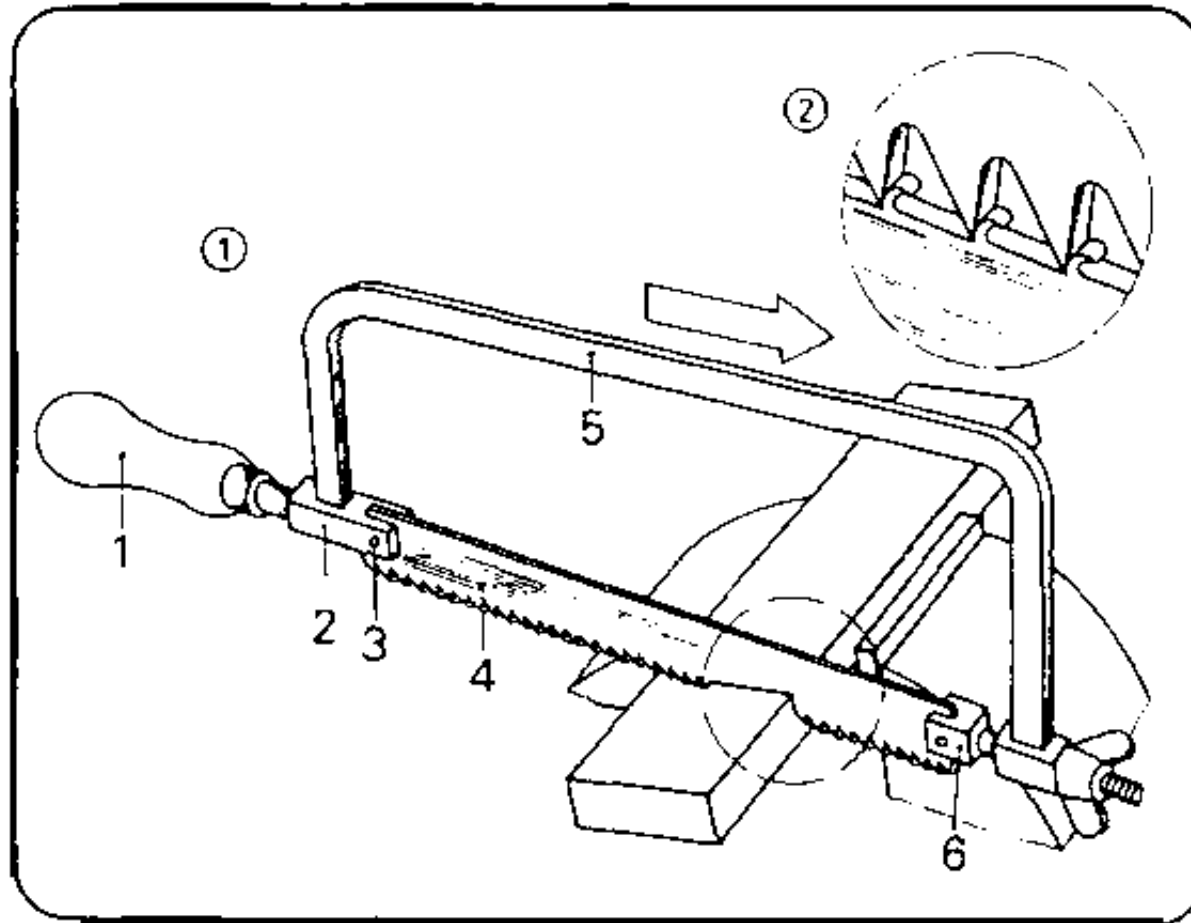

Figure 4.1

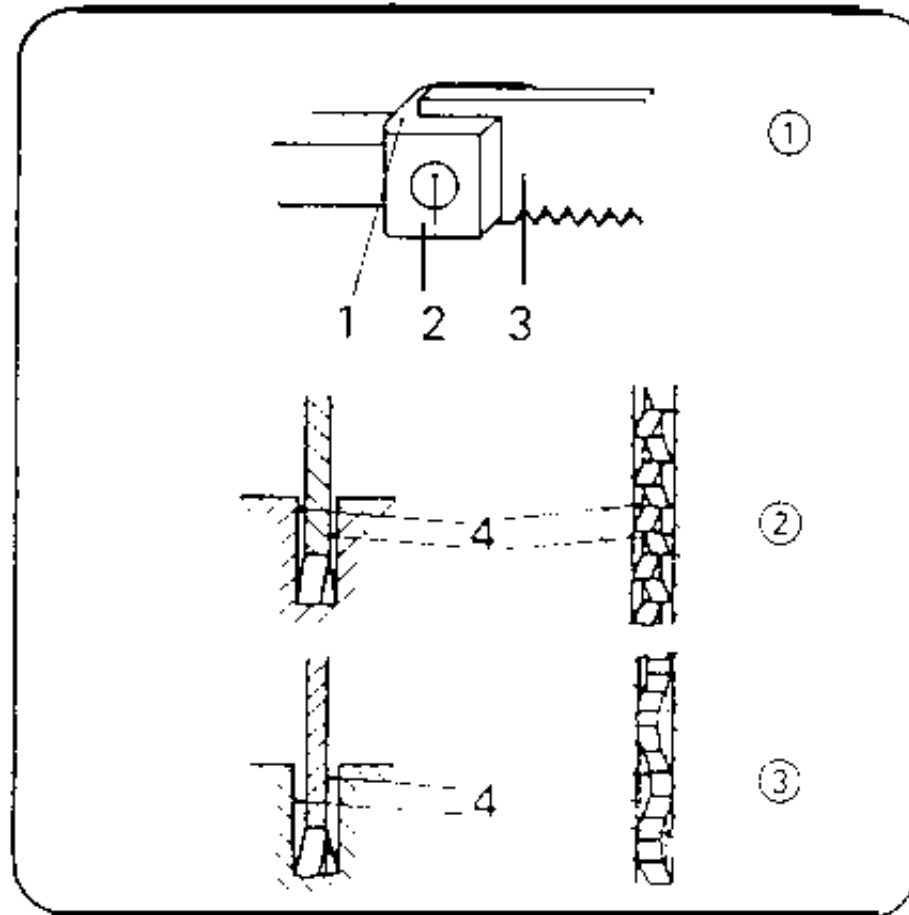

Figure 4.2

The following surveys should support the introduction to saw blades:

Saw blades for different material hardness

Hardness of material	chip formation	angle of clearance	wedge angle	rake angle
hard	shaving -			

	small amount of chips	40°	50°	0°
normal	cutting -			
	small amount of chips	20°	65°	5°
soft	cutting -			
	large amount of chips	30°	50°	10°

Saw blades for different cross sections of workpieces and degrees of material hardness

Type of saw blade	cross section of workpiece	material hardness	tooth pitch (number of teeth on 25 mm)
coarse	- solid sections (round, square and hexagonal steels)	soft steel, non-ferrous metals	14
normal	- normal sections (angles, sectional steel) - thick sheet metal	steel of normal hardness, harder light metals	22
fine	- light-steel sections - thin sheet metal	harder steel, cast iron	32

The instructor has to stress the importance of the free cutting action of saw

blades.

For the purpose of demonstration one trainee is to be given the task to perform a sawing cut on any workpiece using a saw blade with free cutting action first, and then a saw blade without (or with poor) free cutting action. The trainees have to register the required times for sawing and to draw the necessary conclusions.

They will recognize that more time and energy is necessary for the use of saw blades without or with poor free cutting action due to the frequent jamming.

Subsequently, the trainees have to answer the questions contained the “Trainees’ Handbook of Lessons”. The following order is recommended when introducing the accessories:

- vice**
- vee clamps**
- angle clamps**
- protective jaws.**

It must be stated quite clearly why these accessories have to be used - this should be supplemented by employing transparency no. 4.5.

If some of these tools and accessories should not be available as originals, the respective illustrations in the “Trainees’ Handbook of Lessons” could supplement the instruction.

Effects of sawing, posture and saw guidance

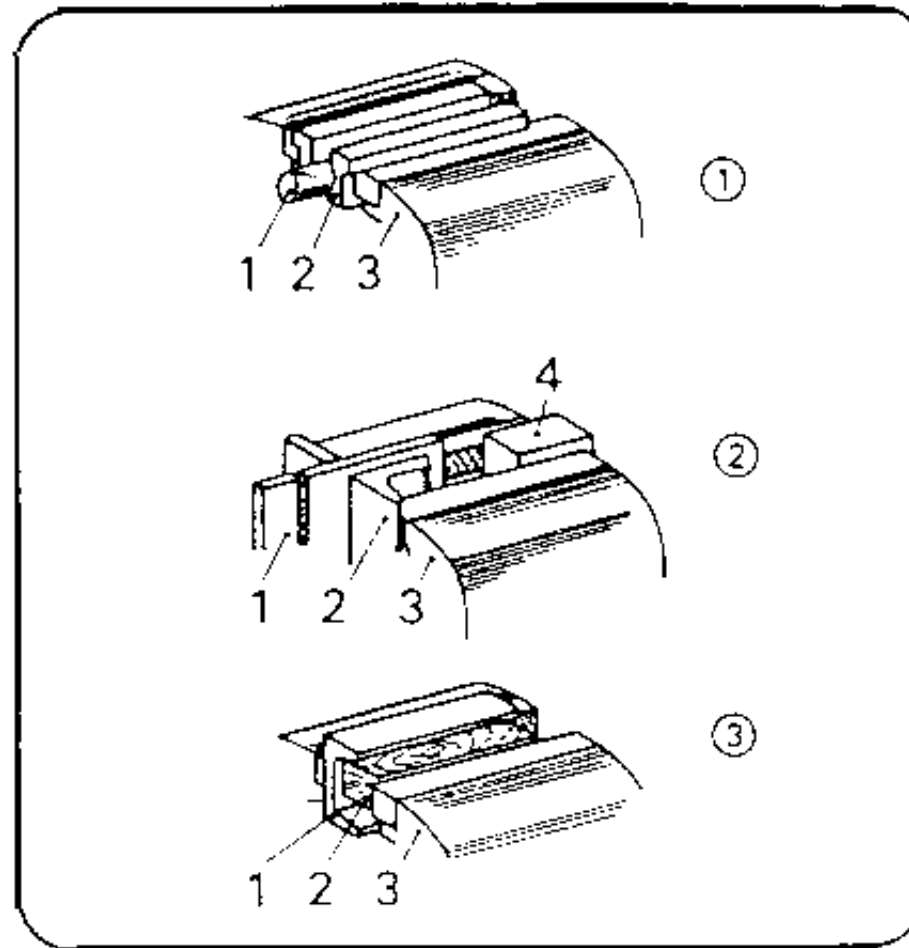

Figure 4.3

Demonstrations should show these effects when cutting a broad and a narrow workpiece each. The trainees will see that the saw will cut better when many teeth are cutting at the same time. This requires a different handling of saws.

In this context the trainees should be shown the proper posture and guidance of the saw.

The “Trainees’ Handbook of Lessons” contains specific hints for this subject which must be taken into account.

How to handle the saw

The trainees have to be shown the close connection between a vertical guidance of the cut and the proper clamping of the workpieces. The following examples need particular explanation:

- **Clamping of flat workpieces for sawing on their broad side.**
- **Clamping of sheet metal and sawing with upward pushing direction.**
- **Clamping and repeated re-clamping when sawing tubes.**
- **Fixing of angle sections and sawing on the broad side only.**
- **Sawing of deep cuts with the saw frame swivelled by 90°.**

These facts should be further illustrated when working in the workshop.

3.2. Exercises

If it was not possible to include the individual demonstrations into the instructions, they should be performed right now before the exercises.

If the trainees avail of only little practical skills, they should do some preliminary exercises on any small workpieces:

- **simple cutting of flat and square steel**
- **cutting of tubes and angle sections**
- **sawing of straight and angular recesses.**

But it is also possible to begin with the first exercises contained in the “Instruction Examples for Practical Vocational Training” at once.

However, it is necessary to prepare any individual exercise by a brief “Job-related instruction”. Within this context the trainees are shown a finished workpiece in order to make them familiar with the aim and purpose of this exercise.

The instructor must have completed such a workpiece by himself so as to know the problems involved in manufacturing it.

This makes it possible to determine the main points in evaluating the trainees' performance and to advise the trainees on problems involved.

During these lessons of special instruction the trainees have to place the sequences of operations and working drawings of the training examples on their desks so that they can make notes therein.

All the trainees can carry out these exercises simultaneously, if the required number of working tools is available. If this is not the case, the trainees will be divided into groups based on the respective tasks and the number of the working tools available.

Those trainees who cannot start their practice of sawing immediately should do some other jobs in the workshop first:

- selection and preparation of the initial materials,**
- checking and minor repair work on working tools under supervision of an**

instructor; other exercises can reinforce the skills of working techniques acquired earlier.

3.3. Examples for recapitulation and tests

This section comprises questions for consolidating and testing the acquired knowledge and skills. Each question is provided with the respective answer. Questions which are also contained in the "Trainees' Handbook of Lessons" are marked with the letter "A".

1. What is the purpose of sawing?

(Cutting of workpieces in a narrow saw kerf in order to divide them or to provide them with slots or cuts.)

2. How do the various types of saw blades differ?

"A" (Design of angles at the saw tooth, number of teeth on a length of 25 mm.)

3. What saw blade do we use when sawing steel of normal hardness?

(Saw blade with medium tooth pitch and cutting-type chip formation.)

4. Why is the free cutting action necessary for saw blades?

"A" (This is to prevent them from jamming in the kerf.)

5. Which are the common design-based ways of achieving the free cutting action?

(Raker-setting of saw teeth, wave-setting of teeth.)

6. What is to be taken into consideration when clamping a workpiece for sawing purposes?

“A” (The workpiece is to be clamped in a way that allows a vertical sawing cut and prevents the workpiece from springing and slipping.)

7. Which is the most important clamping device for workpieces?

“A” (Vice.)

8. Which types of workpieces have to be clamped in vices by means of protective jaws?

(Workpieces with coated or sensitive surfaces.)

9. Why must we guide the saw in such a way that as many teeth as possible are cutting at the same time?

“A” (If only a few teeth are cutting, there will be the danger of hooking in and breaking out of teeth.)

10. What is to be taken into consideration when sawing off workpieces?

“A” (Immediately before the workpiece is sawn off, the pressure on the saw must be reduced so that the saw blade will not be damaged by a torn off workpiece.)

11. How is the saw to be handled when sawing thin metal sheets?

“A” (Saw must be held slightly upwards in the pushing direction.)

12. How is the saw to be handled when sawing tubes and sectional steel?

“A” (Tubes and steel sections must not be sawn off in one pass, but they have to be re-clamped during sawing so that as many teeth as possible will be cutting at the same time.)

4. Application of the working technique of “Manual Sawing”

The sequence of exercises can follow the order of the 7 (or 6) aces mentioned in the “Instruction Examples for practical vocational training - Manual Sawing”.

These “Instruction Examples...” comprise a list of materials (initial materials, hand tools, measuring and testing tools, accessories) as well as the sequence of operations for manufacturing these workpieces. Thus, the trainees avail of the necessary information to begin their exercise-related work. Should the quality of the manufactured workpieces be considered insufficient, the trainee has to carry out comprehensive preliminary exercises. To do so, any waste components will do. If the skill has been practised sufficiently, the envisaged workpiece can be manufactured.

The following hint should be taken into consideration:

The trainee has to do all the work alone - from the very beginning (cutting of initial material) till the completion of the workpiece.

This is the only way to guarantee a just evaluation of the achievements. Should the offered “Instruction Examples...” not be used in the exercises, then it is also possible to select other workpieces. In this case all the working techniques acquired earlier should also be practised with these workpieces.

4.1. Instruction examples

What follows is a brief description of the individual training examples in order to give a survey of those workpieces on which the previous knowledge is to be verified:

Instruction Example 4.1.

Spacers and Pin Drifts

Flat steel and aluminium sheets as well as round material of copper and brass are used to practise simple, straight saw cuts. The finished parts can be employed as necessary accessories in workshops: spacers for clamping, pin drifts for loosening pin connections.

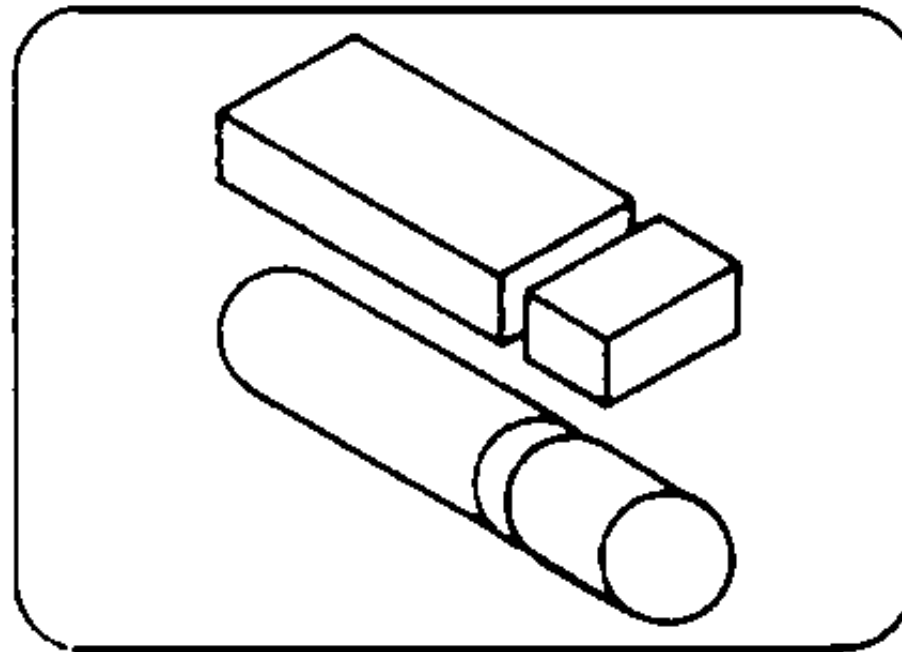

Figure

Instruction Example 4.2.

Stands and Supports

Channel sections and steel tubes serve to practise the specific skill of cutt-off sawing. Repeated re-clamping of the workpiece is a must.

Channel can be further worked in order to manufacture drill stands etc. The instruction examples 2.3. and 7.4. give a description of continuing this work. The tubes can be prepared in such a way that they can serve as supports for instruction example 4.6.

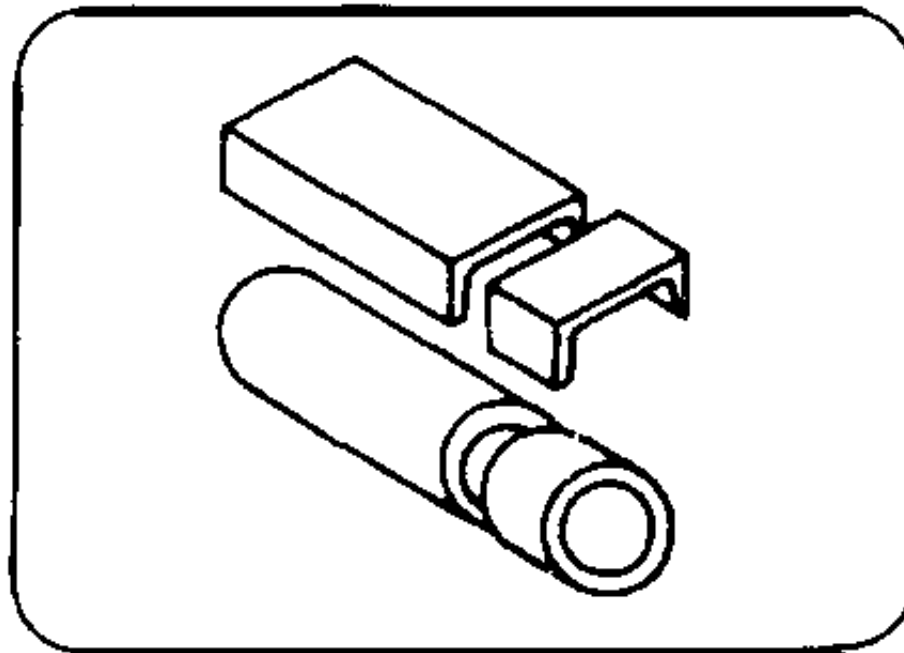

Figure

Instruction Example 4.3.

Container

Light metal or steel sheets or tubes will be sawn to given dimensions to practise

mitre cuts. After glueing, soldering or welding, these components can serve as containers for pins or scribers.

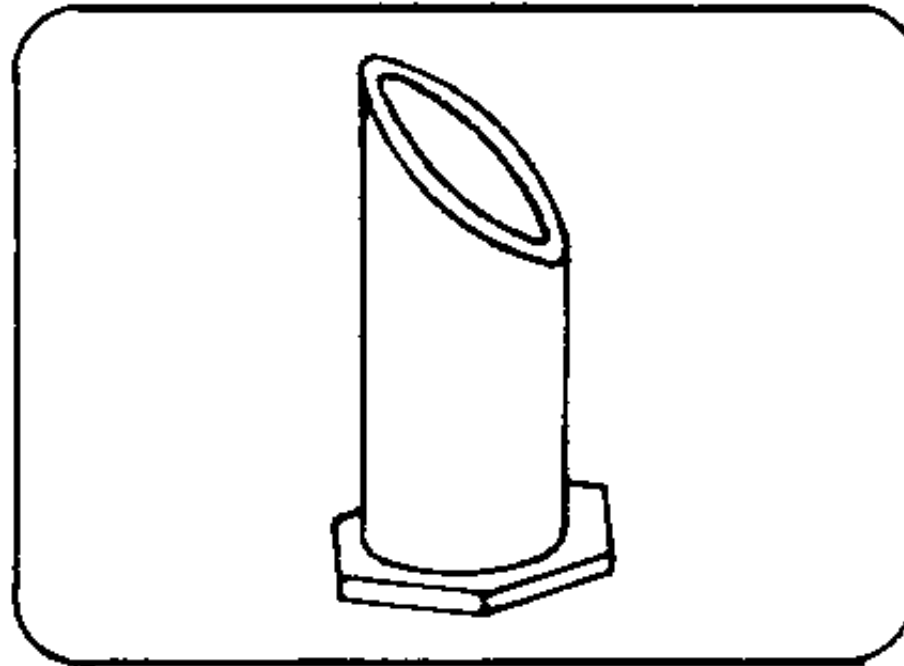

Figure

Instruction Example 4.4.

Vee-shaped-Attachment

Steel sheet will be cut to size by long and straight sawing cuts; solid square steel will be sawn by mitre cuts (the required angle will be given by the instructor). After-having connected these components by bolts or rivets this workpiece can be used as accessory for clamping cylindrical workpieces.

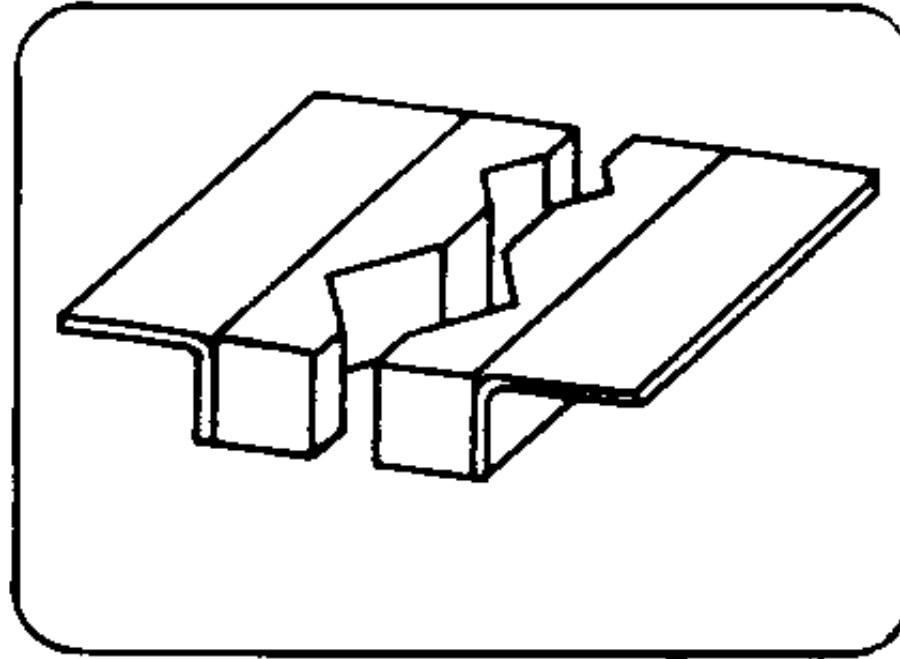

Figure

Instruction Example 4.5.

Steel Square

Long and straight sawing cuts of high precision are practised on steel sheets. Once completed, the workpiece can be used in the workshop.

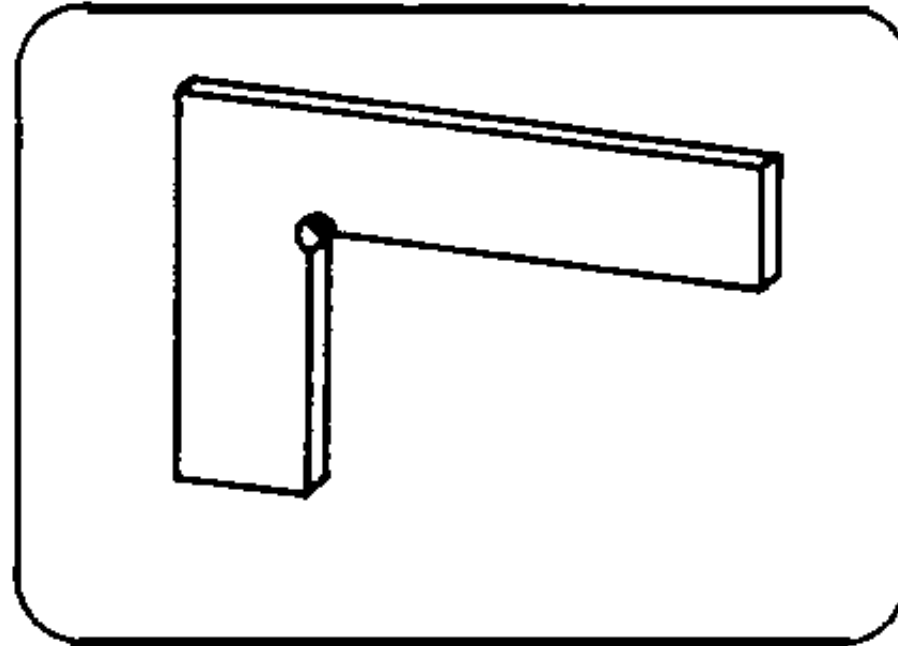

Figure

Instruction Example 4.6.

Angle-Steel Frame Table

Straight and mitre cuts serve to practise the technique of joining angle steel to form a frame.

Emphasis is to be laid on the peculiarities of straight and mitre cuts. Welded with the supports mentioned in instruction example 4.2., a frame for a table is produced which can be provided with an insert (of steel or wood) so as to form a table for putting down tools etc. in the workshop.

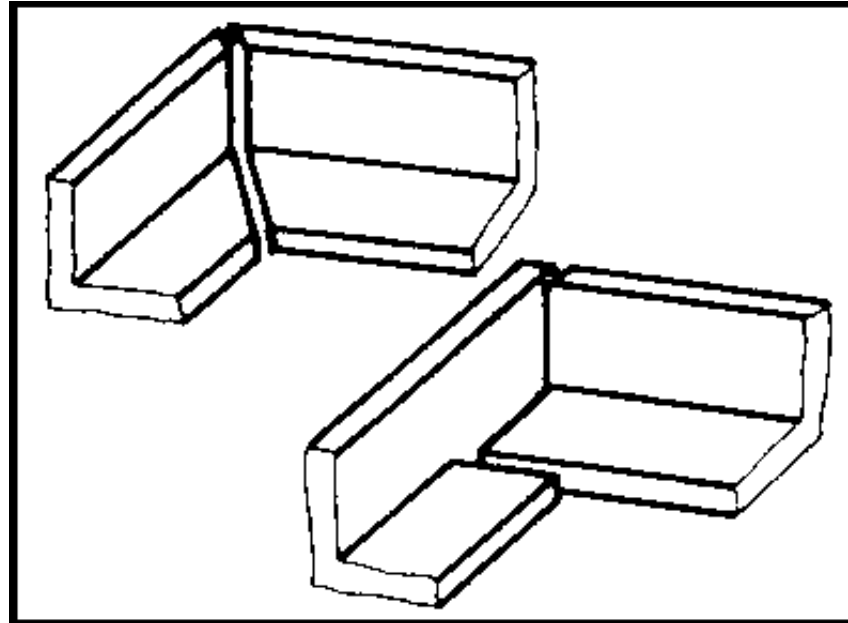

Figure

Instruction Example 4.7.

Wall-Shelf-Bracket

Angle steel is used to practise mitre cuts and cut-outs. When combined with other working techniques, a set of brackets for wall shelves can be produced.

These brackets can be bolted into the wall and provided with a board of any length - and this results in a useful and solid place for laying down workshop accessories

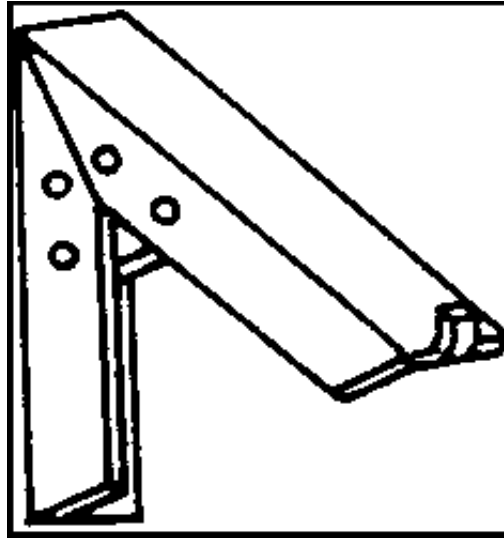

Figure

4.2. Criteria for practical training

It is recommended to determine some major points of observation and evaluation of the work performed.

The following criteria may serve as a guideline:

Does the trainee select the appropriate saw blade?

Does he fix the saw blade in the proper way (in the pushing direction)?

Is the workpiece clamped as required?

Does the trainee use available accessories?

Does the trainee employ cutting oil for sawing?

Does the trainee pay attention to vertical guidance of the saw?

Does the trainee re-clamp sections during sawing or does he saw off in one pass?

Does the trainee pay attention to the fact that there must be as many teeth as possible cutting at the same time even when sawing thin workpieces?

Does the trainee's tool comply with the labour safety requirements?

5. Captions and legends of the "Manual Sawing" transparencies series

Transparency No. 4.1.: Design and operation of a hand hacksaw

(1) Hand hacksaw

1 - handle

2 - fixed clamping dog

3 - retaining pin

4 - saw blade

5 - saw frame

6 - adjustable clamping dog with wing

(2) saw teeth in action

Transparency No. 4.2.: Fixing and free cutting action of saw blade

(1) Fixing of saw blade

1 - clamp dog

2 - rivet or pin

3 - saw blade

- (2) action of saw blade with raker-set teeth
- (3) action of saw blade with wave-set teeth
- 4 - free cutting action

Transparency No. 4.3.: How to clamp a workpiece for sawing

- (1) Clamping a round workpiece with vee clamp as attachment
 - 1 - workpiece
 - 2 - vee clamp
 - 3 - vice
- (2) clamping a metal sheet with angle clamp as attachment
 - 4 - spacer
- (3) clamping a channel section with hardwood attachment

