



➔ **Manual Working of Material/Metal - Course: Manual working of metal. Methodical course-guide for instructors (Institut für Berufliche Entwicklung, 120 p.)**

 **(introduction...)**

 **Introduction**

 **1. Aims and contents of the course**

 **2. Organizational preparation of training**

3. Accomplishment of the training

 **3.1. General recommendations for the procedure of the course**

 **3.2. Introductory instruction**

 **3.3. Exercises with accompanying instructions**

 **3.4. Final instruction**

Chipping





 **1. Objectives and contents of practical vocational training in the working technique of "Chipping"**







 **2. Organizational preparations**

 **3. Recommendations for practical vocational training in the working technique of "Chipping"**

 **4. Application of the working technique of "Chipping"**

 **5. Captions and legends of the "Chipping"**

- **transparencies series**
 - **Riveting**
 -  **1. Objectives and contents of the practical vocational training in the working technique of "Riveting"**
 -  **2. Organizational preparations**
 -  **3. Recommendations for practical vocational training in the working technique of "Riveting"**
 -  **4. Application of the working technique of "Riveting"**

 -  **5. Captions and legends of the "Riveting" transparencies series**
 - **Grinding of Simple Tools**
 -  **1. Objectives and contents of practical vocational training in the working technique of "Grinding of Simple Tools"**
 -  **2. Organizational preparations**
 -  **3. Recommendations for practical vocational training in the working technique of "Grinding of Simple Tools"**
 -  **4. Application of the working technique of "Grinding of Simple Tools"**
 -  **5. Caption and legends of the "Grinding of Simple Tools" transparencies series**
 - **Shearing**
 -  **1. Objectives and Subject Matters of Vocational Training in Shearing Techniques**

- **2. Organizational Preparations**
 - 📄 **(introduction...)**
 - 📄 **2.1. Planning the Training in Shearing Techniques**
 - 📄 **2.2. Preparing the Instructions on Labour Safety**
 - 📄 **2.3. Providing the Teaching Aids**
 - 📄 **2.4. Providing the Working Means**
- **3. Recommendations Regarding Execution of Vocational Training in Shearing Techniques**
 - 📄 **(introduction...)**
 - 📄 **3.1. Introductory Instruction**
 - 📄 **3.2. Practical Exercises**
 - 📄 **3.3. Examples for Recapitulation and Control**
- **Bending**
 - 📄 **1. Aims and Contents of Practical Vocational Training in the Techniques of Bending**
 - 📄 **2. Organizational Preparations**
 - 📄 **3. Recommendations for Implementing Vocational Training in Bending Techniques**
- **Straightening**
 - 📄 **1. Aims and Contents of Practical Vocational Training in the Techniques of Straightening**
 - 📄 **2. Organizational Preparations**
 - 📄 **3. Recommendations for Implementing Practical**

- **Vocational Training in Straightening Techniques**
 - **Annealing, Hardening, Tempering**
 - 📄 **1. Objectives and Contents of the Vocational Training in the Working Techniques "Annealing, Hardening, Tempering"**
 - **2. Organizational Preparations**
 - 📄 *(introduction...)*
 - 📄 **2.1. Preparation of Labour Safety Instructions**
 - 📄 **2.2. Preparation of Means of Instruction**
 - 📄 **2.3. Preparation of Working Means**
 - 📄 **2.4. Planning of Training Phases**
 - **3. Recommendations for the Execution of the Vocational Training in the Working Techniques "Annealing, Hardening, Tempering"**
 - 📄 *(introduction...)*
 - 📄 **3.1. The Introductory Instruction**
 - 📄 **3.2. The Exercises**
 - 📄 **3.3. Examples for Recapitulation and Control**
 - 📄 **4. Explanations to the Means of Instruction**



[Home](#)"" """"> [ar.cn.de.en.es.fr.id.it.ph.po.ru.sw](#)



 **Manual Working of Material/Metal - Course: Manual working of metal. Methodical course-guide for instructors (Institut fr Berufliche Entwicklung, 120 p.)**

  **(introduction...)**

 **Introduction**

 **1. Aims and contents of the course**

 **2. Organizational preparation of training**

3. Accomplishment of the training

Chipping

Riveting

Grinding of Simple Tools

Shearing

Bending

Straightening

Annealing, Hardening, Tempering

**Institut fr berufliche Entwicklung e.V.
Berlin**

**Original title:
Lehrgang Methodische Anleitung fr den Lehrenden
"Manuelle Werkstoffbearbeitung/Metall"**

First edition © IBE

Institut fr berufliche Entwicklung e.V.
Parkstrae 23
13187 Berlin

Order No.: 90-32-0002/2



[Home](#) > [ar.cn.de.en.es.fr.id.it.ph.po.ru.sw](#)



 **Manual Working of Material/Metal - Course: Manual working of metal. Methodical course-guide for instructors (Institut fr Berufliche Entwicklung, 120 p.)**

  **Bending**

-  **1. Aims and Contents of Practical Vocational Training in the Techniques of Bending**
-  **2. Organizational Preparations**
-  **3. Recommendations for Implementing Vocational Training in Bending Techniques**

Manual Working of Material/Metal - Course: Manual working of metal. Methodical course-guide for instructors (Institut fr Berufliche Entwicklung, 120 p.)

Bending

1. Aims and Contents of Practical Vocational Training in the Techniques of Bending

After having terminated their training, the trainees shall be able to surely master the most common techniques of bending procedures. For that purpose, the following aims have to be achieved:

Aims

- The trainees will have profound knowledge of kinds and fields of application of the working means to be used for bending.**
- They will master the different techniques to be used for bending sheet metals, pipes and sections with various tools, appliances and machines.**
- They will be enabled to select the appropriate working means according to the kind of material, material thickness and shape of bending.**
- The trainees will be capable of adequately employing the tools, appliances and machines while adhering to the health, labour safety and fire protection regulations.**
- They will know how to assess the quality of their work themselves.**

To reach the objectives so demanded, the following subject matters have to be imparted by the instructor:

Contents

- Knowledge:**

- **Purpose of bending**
- **Kinds and fields of application of tools, appliances and machines**
- **Phenomena occurring in the material**
- **Fundamentals of calculation**
- **Bending techniques**
- **Hints on labour safety**

- Skills:

- **Folding, turning over, flanging, seaming, crimping, rounding of, and rolling of sheet metals**
- **Rounding of sections and pipes**
- **Rolling of sections**

2. Organizational Preparations

To ensure a trouble-free course of instructions, exercises, and vocational practice, it is necessary to prepare the training well, with the following measures to be taken:

2.1. Planning the Training in Bending Techniques

Proceeding from the total hour volume, the times for the individual training sections of this vocational unit should be planned in a differentiated manner.

It is recommended to draw up a time schedule for the subsequent training sections:

- for introducing the techniques in the form of instruction**
- for necessary demonstrations**

- for instructions to prepare the practical exercises
- for executing the practical exercises
- for recapitulation and controls.

While the hours are being scheduled, the following additional factors are to be taken into consideration:

- the trainees' educational level
- the training conditions
- the trainees' future employment
- the degree of difficulty of the training section.

The focus of each training section is always the acquaintance of practical skills and abilities by exercises, which will take the most comprehensive period of time.

2.2. Preparing the Instructions on Labour Safety

Before the practical exercises begin, the trainees are briefly instructed on the adequate handling of working means and given recommendations for an accident-free work. In general, those regulations are valid which are to be observed for manual techniques in hammering and straightening.

Especially, the following key points should be observed:

- Use only proper hammers - the hammer shaft must be tightly wedged with the hammer head.
- Select the correct striking plate with regard to the form of bending - a hard

and inflexible surface is required.

- **Workpieces to be campled have to be tightly fixed in the clamping fixture so that they are not torn away by the striking impact.**
- **Always strike against the fixed vise jaw so that the vise screw will not be damaged.**
- **Mind your hands and head when working on presses.**
- **Work with welding torches must not be performed until the instructor has given the necessary instructions.**
- **Always observe fire protection - place ready water for fire fighting, do not work close to inflammable materials.**
- **Only bend sheet metals and sections over 8 to 10 mm thickness and pipes of more than 1/2 " in a heated state.**
- **Use only dry sand as filler for hot bending of pipes to avoid steam formation.**

Knowing about these hints is to be confirmed by the trainees' signing in the control book.

2.3. Providing the Teaching Aids

- **The "Trainees' Handbook of Lessons - Bending" is to be distributed among**

the trainees according to their number.

- **Illustrations contained in the "Trainees' Handbook of Lessons" and having a high indicative value should be used as visual aids (e.g. on flip charts, blackboards etc.)**
- **Workpieces showing well and badly performed bendings may be provided as visual objects.**
- **Particular tools and appliances not yet known to the trainees should also be used as visual illustrations, the same applies to brochures and photos of bending machines.**
- **If transparencies on bending are available, they should, in any case, be included in the instruction.**

2.4. Providing the Working Means

- **The "Instruction Examples for Practical Vocational Training - Bending" as theoretical basis for the practical exercises to be performed should be distributed according to the number of trainees.**
- **The basic material required for the exercises should be prepared and provided with the help of the specification of materials given in the "Instruction Examples" in sufficient quantity.**
- **The workshop should be checked whether or not it is completely equipped with tools, appliances, machines, measuring and testing means as well as**

auxiliary means as to the exercises planned.

- Recommended basic outfit:

- **Steel rule, steel square, vernier caliper**
- **Steel scribe, centre punch**
- **Smooth files, hand hack saw, hand-lever shear**
- **Machinists' hammer, light metal hammer, special hammers for sheet metal working**
- **Straightening plate, surface plate, vise**
- **Various intermediate plates and bending mandrels**
- **Drills and counterbores**
- **Hand screw press, bending devices, folding bench, rolling device**
- **Welding torch, dry sand**

- Machines to be employed for bending have to be checked as to their serviceability with regard to labour safety before starting the exercises.

- For necessary drilling and counterboring operations, a table-type or column-type drilling machine with appurtenant clamping fixtures is required.

- Check serviceability of this machine prior to the practical exercises with regard to labour safety.

3. Recommendations for Implementing Vocational Training in Bending Techniques

The following sections contain proposals on how to arrange the trainees' instruction, the demonstration of techniques as well as exercises and controls.

3.1. Introductory Instruction

The introductory instruction should be given, if possible, with the trainees in a classroom. Attention is to be paid during the instruction to the trainees' noting down necessary additions or replies to questions in the "Trainees' Handbook of Lessons". An essential prerequisite for learning the bending techniques is the trainees' mastering the techniques in testing and hammering. This knowledge should be repeated, if necessary.

For your instruction you can use the "Trainees' Handbook of Lessons" with the following focal points:

Purpose of bending

Initially, it would be favourable to explain to the trainees the purpose of bending with the help of visual objects and illustrations. In this connection, it must be made clear that bending is, due to its versatility, used in many fields of manufacture and performed by various techniques. Predominantly, the techniques in folding, turning over, flanging, seaming, rounding and rolling should be discussed.

Selected tools, appliances and machines

Out of the variety of applicable working means it is recommendable to introduce or repeat the following:

- Hammer**
- Welding torches**
- Angle bending appliances, strip rolling devices, pipe benders**

- **Screw presses**
- **Folding bench, rounding device, crimping and flanging machine**
- **Vise, blacksmith's anvil**

These working means may also be dealt with in a question-answer talk with the trainees, as far as the trainees have previous knowledge. Already here, particular characteristic features in their application can be stressed. If tools cannot be shown, the trainees should have a look at the illustrations in the "Trainees' Handbook of Lessons".

Processes in the material

During this instruction section, the tensile and compressive stresses and their effects occurring during the bending process are to be discussed. The terms "stretching and upsetting" as well as "neutral axis" have to be explained.

In this connection, it is recommended to show the stretching and upsetting zone on a spot of rupture of a square section strongerly bent. It is also favourable to make a blackboard drawing as to Fig. 14 of the "Trainees' Handbook of Lessons" to show the neutral axis.

Subsequently, the influences of such material properties like "plasticity", "elasticity", "strength" and "strain hardening" are to be explained.

The trainees should keep in mind the knowledge so acquired in the form of rules and key sentences.

To deepen the knowledge, the trainees have now to answer the questions asked in

the "Handbook of Lessons" following the respective section.

In supplement of the influence data depicted just now, the influences of the bending radius, particularly the minimum bending radius, and the influences of heat reaction for the quality of bending can be discussed.

It is recommendable to put side by side a hot bent and a cold bent square section of 16x16. The trainees are to state the differences in quality of bending and derive from it the findings for their own work.

Fundamentals of calculation

Comprehensively dealing with this focus is essential. The trainees are to be explained the necessity of the exact blank of the basic material. As for calculating the blank size, the straight length in dependence of the neutral axis position must be ascertained first.

The formulae required for it are distinctly introduced in the "Trainees' Handbook of Lessons".

With an example of application it is demonstrated that the blank length can be calculated out of a sum of different partial lengths. Here, the trainees should develop more examples for calculation to be solved by them without assistance, if possible.

Bending techniques

The techniques depending on material thickness and form of bending edge, as

mentioned in the beginning, are described in the "Trainees' Handbook of Lessons", in principal.

Versions for each technique are shown, describing the manual making of bends with hammers or with mechanical devices as well as machines. It is not recommendable to describe the techniques all together during the lessons, what is more, it is favourable first to only explain the bending procedures which can be practised in the workshop with the help of existing working means.

That means that following the description of folding sheets practical exercises should be done, applying immediately in practice the knowledge just imparted.

Subsequently, the following techniques will be dealt with in the same way.

It would be better, in case of slow learners or those having only a small previous knowledge, to impart the know-how in small, closely restricted sections and then support it with respective practical exercises.

Hints on Labour safety

Give the essential hints at the respective place, when bending procedures to be performed are described. These recommendations are contained in the text and as a compilation in the "Trainees' Handbook of Lessons".

3.2. Practical Exercises

Basically, the necessary hints on labour safety have to be given prior to the practical exercises. Then, the trainees receive their working places and the technical

equipment of the workshop is checked as to its serviceability. It is recommended to start any exercise with a demonstration in connection with the teacher's instruction related to the instruction example. Here, the trainees are to be motivated to perform the exercises in good quality. Difficulties to be expected have to be pointed out and evaluation key assessment should be mentioned at the same time.

It is necessary for the instructor to have previously performed the exercise himself.

Only in such a way does he know the difficulties that may arise during its execution.

The course of exercise may be in change of instructions on the special techniques and the appurtenant exercises. With the help of "Instruction Examples for Practical Vocational Training - Bending", 6 practical exercises can be done by applying different techniques.

For that purpose, the "Instruction Examples....." contain a material list (base material, tools, appliances, measuring and testing instruments as well as auxiliary means), the sequence of operations to carry out the practical exercises and an illustrative working drawing. The trainees receive all the required information in it to be able to perform the exercises purposefully.

To give a survey, to which practical pieces the knowledge previously imparted is to be applied, the following individual instruction examples are briefly described.

Instruction examples:

Instruction example 14.1.: Mounting angle

Sheet metals of 1 mm and 2 mm thick steel are to be folded in the vise. For that purpose, a sheet with a simple bending edge is to be bent manually.

A second sheet shall receive two bending edges by means of machinist's hammer and intermediate plate.

(Figure 1)

Instruction example 14.2.: Half-round bracket

A sheet steel strip is to be folded and rounded off in the vise with the help of a bending mandrel so that a serviceable half-round bracket is the result. Before bending, the straight length is to be calculated.

(Figure 2)

Instruction example 14.3.: Hasp

During this exercise, a sheet steel is to be rolled on a rolling device as well as round sections to be folded and bent to a round object by means of bending mandrels, so that a serviceable hasp will be the result after assembly.

(Figure 3)

Instruction example 14.4.: Double pipe knee

A steel pipe is to be rounded off twice with a bending device as well as with a machinist's hammer in the vise. In this case, sand filler and local heating are to be

applied to. The heating length has to be calculated before.

(Figure 4)

Instruction example 14.5.: Beaker jacket

A thin sheet steel is to be folded with the folding press, turned over and rounded off. Subsequently, a jacket seam joint is fabricated.

(Figure 5)

Instruction example 14.6.: Beaker

The previously fabricated beaker jacket is further worked on. After flanging, a bottom piece is connected with the beaker jacket by a bottom seam joint.

(Figure 6)

All trainees can do the exercises at the same time so far as material and equipment are available in sufficient quantity and number.

In this case, the trainees are able to perform any single exercise individually - each trainee should have as much time as needed.

If there are not enough working means, the trainees must be split into groups. Here it is favourable to divide them into groups according to the application of different tools and appliances.

As versions for the exercises to be done, the bendings can be made with various

working means as well.

In such a way, foldings should not only be made on the vise, but also on the folding press and folding bench. Even so should roundings not only be exercised manually, but also on the rounding-off device, if available.

Should the proposed instruction examples not be used for exercises, it would be possible to select other practising pieces. In this case, attention is to be paid to the fact that all the techniques previously discussed can be practised on these pieces as well.

Focal points for practical execution

It is recommended for the to fix certain criteria for the assessment of the exercises. These could be the following:

- Do the trainees prepare their working places carefully?**
- Is the straight length of workpiece exactly calculated?**
- Is the basic material exactly cut to size?**
- Are the appropriate working means selected and properly operated?**
- Are the workpieces tightly clamped?**
- Do the workpieces receive the required form and accuracy to size?**
- Are workpieces damaged by improper work?**
- Are the trainees able to assess the quality of their work themselves correctly?**
- Do the trainees adhere to the labour safety regulations?**

3.3. Questions for Recapitulation

To strengthen and check the knowledge and abilities so acquired, the following tasks have been made out in this section and are also contained in the "Trainees' Handbook of Lessons":

1) What is the purpose of bending?

(To remodel workpieces that must have angular or rounded shapes for a specified purpose of application.)

2) Which techniques are used for bending of sheet metals?

(Folding, turning over, flanging, seaming, crimping, rounding, rolling.)

3) What does the term "neutral axis" mean?

(Transition zone in the bent workpiece where no tensile and compressive stresses occur.)

4) Which material properties must parts to be bent not have?

(They must not be brittle or spring-tempered.)

5) What does the term "spring-back" (elastic recovery) mean?

(Elastic materials spring back after an action of force by a certain measure.)

6) What will happen when a sheet metal is being bent around a bending edge that is in accordance with the streak flow of rolling direction?

(Cracks may occur on the bending's outer edge.)

7) What does the term "strain hardening" mean?

(When tensile and compressive stresses change for several times, the internal stresses grow and result in hardening at the bending point.)

- 8) Which influence has the bending radius on developing cracks in the workpiece?
(The larger the bending radius, the smaller the risk of cracks.)**
- 9) Which influence has workpiece thickness on bending radius?
(The thicker the workpiece, the larger the bending radius must be.)**
- 10) Which influence has the material heating on the bending procedure in case of thick workpieces?
(With growing heat, the internal resistance within the material decreases, the bending procedure becomes easier and is without risk of crack formation.)**
- 11) What does the term "stretched length" mean?
(Length of workpiece before being bent; is calculated from the neutral axis length.)**
- 12) How does the position of the neutral axis change when workpieces are bent around a radius that is smaller than five times the workpiece thickness?
(It shifts to the internal side of the bending.)**
- 13) How is the stretched length of a workpiece calculated, if several different bendings have to be effected?
(Each bending is calculated individually as a partial length, then the partial lengths are summerized.)**
- 14) To which side have you to hammer when a sheet metal is to be folded on the vise?
(Towards the side of fixed jaw.)**
- 15) Which side of the workpiece has to be scribed with the steel scriber?**

(On the bending's internal side.)

**16) From which sheet thickness onwards should workpieces be hot-bent?
*(From 8 mm sheet thickness onwards.)***

**17) What is the significance of hardwood or metal intermediate plates for bending on the vise?
*(They serve to compensate distances when workpieces with several bending edges are to be folded. They also absorb the impact when you strike with a machinist's hammer.)***

**18) How are sheets with long bending edges clamped in the vise?
*(With sheet clamp or angular sections, both being additionally fixed with a ferrule.)***

**19) What is to be done before sections are folded?
*(Prior to bending, the upsetting zone is to be separated.)***

**20) How are sheet metals to be turned over?
*(They are folded by 90° and turned over with presses or hammers to a bending angle of up to 180°.)***

**21) How is a sheet metal cylinder flanged manually?
*(Slightly flange with the hammer pane (striking face of a hammer) on the bordering tool and finish flanging with the hammer face on a plane striking plate.)***

**22) By which working steps is seaming marked?
*(Turning over with shims, hooking-in, pressing together.)***

23) What does "crimping" mean?

(Producing curl-like recesses in sheets to stiffen the metal.)

24) How can sheet metals be rounded off in a vise?

(Clamp the sheet with the bending form and turn it over step by step with the hammer.)

25) With which appliances can sections be rounded off?

(With bending devices, bending dies, section bending machines, swage block.)

26) What is to be noted when pipes of over 1/2" in diameter are rounded off?

(Pipe must be filled with sand prior to being bent.)

28) What is to be noted when welded pipes are rounded off?

(Welding seam must be lateral to bending radius in neutral axis.)

29) Which length has to be exactly calculated prior to hot-bending?

(The bend length to be heated.)

30) How is the bend length scribed?

(From the dimension length, the dimension leg is scribed to one side on the unbent pipe and the bending leg to the other side.)

31) How may sheet rims be rolled?

(With hammers on round sections, with devices or presses.)

32) How may springs be wound?

(Mechanically with lathes or manually with winding mandrels and wood clamp in

the vise.)



[Home](#) > [ar](#).[cn](#).[de](#).[en](#).[es](#).[fr](#).[id](#).[it](#).[ph](#).[po](#).[ru](#).[sw](#)



 **Manual Working of Material/Metal - Course: Manual working of metal. Methodical course-guide for instructors (Institut fr Berufliche Entwicklung, 120 p.)**

  **Straightening**

-  **1. Aims and Contents of Practical Vocational Training in the Techniques of Straightening**
-  **2. Organizational Preparations**
-  **3. Recommendations for Implementing Practical Vocational Training in Straightening Techniques**

Manual Working of Material/Metal - Course: Manual working of metal. Methodical course-guide for instructors (Institut fr Berufliche Entwicklung, 120 p.)

Straightening

1. Aims and Contents of Practical Vocational Training in the Techniques of Straightening

After having completed their vocational training, the trainees shall master the most commonly used techniques of straightening. For this purpose, the following has to be achieved:

Aims

- **The trainees have thorough knowledge of the kinds and fields of application of the working means for straightening.**
- **They master the different techniques that can be used for the straightening of materials in cold and hot condition.**
- **They are able to decide for the appropriate technique according to the kind of deformation.**
- **The trainees are able to choose tools, devices and auxiliary equipment according to the respective purpose and to use them skilfully and observing the regulations on health and labour safety as well as fire protection.**
- **They are able to assess the quality of their work themselves.**

In order to achieve these aims, the instructor has to impart the following contents:

Contents

Knowledge

- **Purpose of straightening**
- **Kinds and fields of application of tools, devices and auxiliary equipment**

- **Processes in the material**
- **Techniques of straightening**
- **Hints on health and labour safety**

Skills

- **Straightening of bendings and bucklings**
- **Straightening of distortions**
- **Straightening of dents and corrugations in metal sheets**
- **Straightening of cold and heated materials**

2. Organizational Preparations

To ensure a trouble-free course of instructions, exercises and vocational practice, it is necessary to prepare the training well, with the following measures to be taken:

2.1. Planning the Training in Straightening Techniques

Starting from the total hour volume, the hours spent on the individual training sections of this vocational unit should be planned in a differentiated manner. For the following training sections it is recommendable to prepare a schedule:

- **for the introduction to the techniques in the form of an instruction,**
- **for required demonstration,**
- **for the task-related instruction in preparation of the exercises,**
- **for the implementation of the exercises,**

- **for recapitulation and controls.**

In planning the time, the following additional factors are to be taken into consideration:

- **the level of education of the trainees,**
- **the training conditions,**
- **the future field of working of the trainees,**
- **the degree of difficulty of the training sections.**

The acquisition of skills and abilities is the focal point of each training section; therefore, the exercises must be given the major portion of time.

2.2. Preparing the Instructions on Labour Safety

Before beginning with the exercises, a brief instruction has to be given on the appropriate use of tools and equipment and on accident-free working. In general, the same regulations are valid as for hammering and bending.

The following points must be especially emphasized:

- **Use only clean and intact tools and equipment.**
- **When using hammers, make sure that the head of the hammer is firmly connected with the shaft by the cotter punch.**
- **Choose the appropriate support - it must have an inflexible surface.**

- **The workpieces must be firmly clamped so that they are not torn away by the hammer blows.**
- **When working at presses make sure that your hands and head are protected.**
- **The use of welding torches is only allowed after previous instructions given by the instructor.**
- **Pay attention to fire protection: place water ready for fire fighting; do not work near inflammable materials.**

Knowledge of these instructions has to be confirmed by the trainees by signature in the control book.

2.3. Providing the Teaching Aids

- **The "Trainees' Handbook of Lessons - Straightening" is to be distributed among the trainees according to their number.**
- **Especially indicative illustrations from the "Trainees' Handbook of Lessons" should be arranged for as blackboard drawings.**
- **Workpieces which have been deformed by transport or machining may be used as visual aids.**
- **Special tools not yet known to the trainees, e.g. moving irons, may be used as visual aids, too.**

- **If in the field of straightening transparencies for overhead projection are available, they should be included in the lessons.**

2.4. Providing the Working Means

- **As a theoretical basis of the exercises to be carried out the "Instruction Examples for Practical Vocational Training - Straightening" should be distributed among the trainees.**

- **The basic material required for the exercises should be prepared and provided in sufficient quantity according to the details given in the "Instruction Examples...".**

- **The workshop has to be checked as to its complete equipment with tools, devices, measuring and testing instruments as well as auxiliary means according to the exercises planned.**

- **Recommended basic equipment:**

- **Locksmith's hammers, straightening hammers, light metal hammers, mallets, rubber hammers**
- **Moving irons and tap wrenches**
- **Tongs and clamps**
- **Welding torches with accessories**
- **Hand screw presses**
- **Vice, straightening plate**

- **Straightening machines that shall be used for mechanical straightening**

must be checked as to their serviceability with regard to safety before starting the exercises.

3. Recommendations for Implementing Practical Vocational Training in Straightening Techniques

The following sections contain suggestions for teaching, demonstrating the techniques and carrying out and tests.

3.1. Introductory Instruction

The introductory instruction should be given, if possible, in a classroom. Make sure that the trainees note down supplements and answers to questions in the "Trainees' Handbook of Lessons".

An important precondition for learning the techniques of straightening is the mastery of the techniques of testing and hammering.

This knowledge must be recapitulated, if required.

For your instruction you can use the "Trainees' Handbook of Lessons" with the following focal points:

Purpose of straightening

It is recommendable to start the lessons by explaining the trainees the purpose of straightening with the help of visual aids. In doing so, it must be made clear that due to transport or machining of the materials deformations may occur, which - for

the moment - prevent a further quality processing of the respective workpiece. The trainees shall understand that the various kinds of deformations can be eliminated by different techniques of hammering, bending and local heating up.

Tools, devices and auxiliary equipment

The possibility to straighten thin metal sheets, pipes and sections by hand has to be mentioned and, in addition, the most commonly used working means have to be introduced and/or repeated, such as:

- Locksmith's hammers, straightening hammers, light metal hammers, mallets and rubber hammers**
- Welding torches, blacksmith's fire, annealing furnace**
- Screw presses, straightening machines**
- Vice, anvil, straightening plates**

These working means may also be dealt with in a question - answer talk with the trainees, provided that the trainees have previous knowledge. Already here, special distinctive features in the use of the working means may be pointed out.

If no tools can be shown, the trainees should look at the corresponding illustrations in the "Trainees' Handbook of Lessons". After this, it is recommendable to have the trainees answer the questions in the "Trainees' Handbook of Lessons" in writing in order to apply the knowledge acquired in this field.

Processes in the material

It is very important to deal with this point thoroughly to explain the trainees basic processes which take place within the material when it is exposed to external forces.

Make sure that the terms of "axial elongation", "compression and elastic recovery" are correctly and clearly explained.

It is recommendable to draw the simple illustrations from the "Trainees' Handbook of Lessons" on the blackboard in order to show the sequences of motions by the individual steps.

As a practical proof, a simple demonstration can be given: A square section - if possible from a very soft material - is given a lattice-shaped marking on the side as is to be seen in Figure 11 of the "Trainees' Handbook of Lessons". Then, the square section is bent. The changed pattern of the lines, which had been parallel before, impressively demonstrates the effects of tensile and compressive stresses.

This must be followed by an explanation of the possibilities of neutralizing these stresses by systematic counterstresses as well as local heating up. Especially it must be emphasized that the internal resistance of a material is reduced by heating it up and that - as a result of this - the workpiece is easier to form. The utilization of this quality should be immediately described on the basis of examples showing the deformation of thick sections and pipes with thick walls.

Techniques of straightening

The various techniques should always be described in connection with the thickness and kind of deformation of metal sheets, pipes and the shape of sections.

In the "Trainees' Handbook of Lessons", these techniques are described according to the kind of deformation. It is not recommendable to explain all techniques together. Rather should the explanation of the straightening of bendings and buckings be immediately followed by a practical exercise, for which the 1st instruction example can be used. This way, the theoretical knowledge is consolidated by practical exercise without delay. Especially for weak trainees or for those who have only a small previous knowledge, it is better to impart the knowledge in small steps followed by corresponding practical exercises. The following sections - straightening of twistings, dents and corrugations in metal sheets - can be treated in the same manner.

The "Instruction Examples for Practical Vocational Training" offer exercises for each of these focal points. The mentioned instruction mainly describe the straightening by hand.

If straightening machines are available, this instruction is to be supplemented with the help of the operating instructions of the respective machine. The instruction directly at the machine would be the most effective one.

Hints on Labour Safety

Taking into consideration the hints on labour safety of the hammering and bending techniques especially applicable points have to be emphasized and supplemented. These focal points are included in the "Trainees' Handbook of Lessons".

3.2. Practical Exercises

On principle, the necessary hints on labour safety must be given prior to the practical exercises. Then, the working places are assigned to the trainees and the technical equipment of the workshop is tested as to its serviceability.

It is recommended to start every exercise with a demonstration by the instructor in connection with an instruction related to the respective instruction example. In doing so, the trainees should be motivated to implement the exercise in a good quality. It must be pointed to difficulties that may perhaps occur. The criteria of assessment must also be mentioned.

It is necessary that the instructor himself has done the exercise before.

Only then he will know the difficulties of the exercise.

Instructions on the special techniques and corresponding practical exercises may alternate.

On the basis of the "Instruction Examples for Practical Vocational Training - Straightening" 5 exercises can be carried out using different techniques. For this, the "Instruction Examples" include a list of the required materials (basic material, tools devices, measuring and testing instruments as well as auxiliary equipment), the sequence of operations for carrying out the exercises and an illustrative working drawing.

Thus the trainees get all necessary information for systematically implementing the

exercises.

The basic material must be deformed according to the defects indicated in the working drawing, so that the exercises can be done according to the respective sequence of operations. If there are workpieces available showing similar deformations they may be used as well.

The following instruction examples give a survey of those practising pieces which should be manufactured for putting the previously imparted knowledge into practice.

Instruction examples**Instruction example 15.1. Straightening of bendings and Ducklings**

This instruction example includes three individual exercises:

A 2 mm thick buckled steel sheet has to be straightened with the help of the flat punch of the hand screw press;

An 8 mm thick buckled flat material has to be straightened by means of the locksmith's hammer in the vice;

A 15 mm thick bent square section has to be heated up with the welding torch and then straightened by means of the locksmith's hammer.

(Figure 1)

Instruction example 15.2. Twistings

This instruction example includes 2 individual exercises:

A 5 mm thick distorted flat material has to be straightened with the help of a moving iron in the vice;

A 10 mm thick distorted square section has to be straightened by means of a moving iron in the vice.

(Figure 2)

Instruction example 15.3. Bent angle section

This instruction example includes 2 individual exercises:

A unilaterally bent angle section of a width of leg of 20 mm has to be straightened by the hammer peen;

A double-sidedly bent angle section of a leg width of 45 mm has to be heated up locally by means of a welding torch and straightened.

(Figure 3)

Instruction example 15.4. Bent pipe

A bent steel pipe of a diameter of 1 inch has to be filled with fine-grained sand, to be firmly closed and then straightened in the vice.

(Figure 4)**Instruction example 15.5. Dented and corrugated metal sheets**

Steel sheets of 3 mm in thickness each and with various defects - such as small dents, one big dent, completely corrugated surface - have to be straightened by means of the straightening hammer. The same metal sheets may also be straightened by means of the roller straightening machine.

(Figure 5)

All trainees can do the exercises at the same time, provided that materials and equipment are available in sufficient quantity and number.

In this case, the trainees can do their exercises individually, i.e. each trainee should get as much time as he needs. If there are not enough working means, groups must be formed. The trainees should be divided into groups according to the use of the different tools and devices.

If you do not like to use the instruction examples offered for the purpose of exercise, you may choose other practising pieces. If this is the case, make sure that all techniques that had previously been explained are practised with these pieces.

Focal points for practical execution

It is recommendable to fix certain criteria for the assessment of the exercises. These could be the following:

- **Do the trainees prepare their working places properly?**
- **Do they select the right tools - as to size and form?**
- **Are the workpieces clamped firmly enough?**
- **Do the trainees meet the quality requirements?**

Especially:

- **Do the workpieces get their correct form?**
 - **Can the workpieces be used for further treatment after straightening?**
-
- **Do the trainees use the correct testing method?**
 - **Are the trainees able to assess their own work properly?**
 - **Do the trainees observe the regulations on labour safety?**

3.3. Questions for Recapitulation

In this section, tasks are compiled to improve and check the acquired knowledge. These tasks are also included in the "Trainees' Handbook of Lessons":

1. What is the purpose of straightening?

(Materials which had been twisted, bent or deformed during transport or machining are given back their original form.)

2. What are the techniques which are manily used for straightening?

(Hammering, bending, local heating up)

3. What hammers can be used for straightening steel sheets?

(Locksmith's hammers, straightening hammers)

4. What hammers can be used for straightening aluminium sheets?

(Light metal hammers, mallets, rubber hammers)

5. For what sort of straightening work are moving irons used?

(For the elimination of twistings in flat sections.)

6. For what sort of straightening work can the hand screw press be used?

(For straightening bent sections and dented metal sheets.)

7. What tensions occur at the bending radii of deformed materials?

(At the external radii it comes to tensile stresses - axial elongations; at the internal radii it comes to compressive stresses - linear compressions.)

8. What happens, if a too little force affects the material?

(The material springs back elastically into its initial position - the extension was elastic.)

9. How are tensile and compressive stresses eliminated at bent workpieces?

(The effects of the systematic application of force or local heating followed by cooling put the workpiece back to its normal form.)

10. What is the advantage of straightening thick sections and pipes with thick walls in red-hot condition?

(The resistance of the material is reduced with increasing heating up this requiring less force for straightening.)

11. How can slightly bent thin sections be straightened?
(Manually in the vice or by means of the press.)

12. How can little bucklings at sections and strips of metal sheets be straightened?
(By clamping the buckled spot in the vice and fastening the jaws or by hammering on a rigid and plane support.)

13. What must be borne in mind when straightening bent pipers?
(Before being straightened, the pipe must be filled with fine-grained sand and firmly closed on either side.)

14. How are large dents eliminated in metal sheets?
(By hammer blows starting from the rim of the bulge and drawing outwards or by local heating up with the welding torch.)

15. Why are better not too many hammer blows applied when straightening with hammers?
(Because by hammer blows the material becomes harder and more brittle, which may lead to the formation of fissures or to fracture.)



[Home](#) > [ar](#) [cn](#) [de](#) [en](#) [es](#) [fr](#) [id](#) [it](#) [ph](#) [po](#) [ru](#) [sw](#)

 **Manual Working of Material/Metal - Course: Manual working of metal. Methodical course-guide for instructors (Institut fr Berufliche Entwicklung, 120 p.)**





- 1. Objectives and Contents of the Vocational Training in the Working Techniques "Annealing, Hardening, Tempering"
- 2. Organizational Preparations
 - (introduction...)
 - 2.1. Preparation of Labour Safety Instructions
 - 2.2. Preparation of Means of Instruction
 - 2.3. Preparation of Working Means
 - 2.4. Planning of Training Phases
- 3. Recommendations for the Execution of the Vocational Training in the Working Techniques "Annealing, Hardening, Tempering"
 - (introduction...)
 - 3.1. The Introductory Instruction
 - 3.2. The Exercises
 - 3.3. Examples for Recapitulation and Control
- 4. Explanations to the Means of Instruction

Manual Working of Material/Metal - Course: Manual working of metal. Methodical course-guide for instructors (Institut fr Berufliche Entwicklung, 120 p.)

Annealing, Hardening, Tempering

1. Objectives and Contents of the Vocational Training in the Working Techniques "Annealing, Hardening, Tempering"

The trainees shall have full command of the most common working techniques of the heat treatment of simple tools, testing devices and machine parts made of unalloyed steel, after having concluded the training.

- The trainees have knowledge of the purpose, the types and spheres of application of the various heat treatment processes.**
- They have command of the structure and the operation of the devices and auxiliary means and are able to use them appropriately by observing labour safety and fire protection regulations.**
- They have knowledge of the preconditions for heat treatment with regard to material engineering and material shaping.**
- They master the various technological routines of the heat treatment processes of annealing, hardening and tempering of tools, testing devices and small machine parts.**
- They are able to carry out quality controls independently.**

2. Organizational Preparations

In order to ensure an undisturbed run of the instructions, exercises and instruction works it is necessary to prepare the training very well. The following measures have, among others, to be taken:

2.1. Preparation of Labour Safety Instructions

Prior to the beginning of the exercises, a short-term instruction with regard to the suitable dealing with working means specifying hints on works not involving accidents have to be given. The following features have to be imparted:

- Wear working garments, aprons and handgloves!
- Protect your eyes by means of protective glasses!
- Do not remove safety devices installed at devices!
- Do not touch cyanide salts and nitrites for melting baths with bare hands!
- Cover melting baths after use.
- Only use predried, cleaned workpieces for heat treatment.
- Take care for fire protection.
- Remove oil slicks on the floor immediately.
- Place hot workpieces only at places marked for that.
- Put in order the tools, devices and auxiliary means after having finished work and keep them clean.
- Do careful hygiene after having finished work.

The knowledge of those hints is to be confirmed by the trainees' signatures in the control book.

2.2. Preparation of Means of Instruction

- **The "Trainees' Handbook of Lessons - Annealing, Hardening, Tempering" is to be distributed among the trainees according to their number.**
- **Charts may be made prior to the instructions as blackboard figures.**

- Coloured tables, figures, originals and models of devices and auxiliary means as well as break samples of heat-treated workpieces may be produced as illustrative material and prepared for the instructions (see section 4).

2.3. Preparation of Working Means

- The "Instruction Examples for the Practical Vocational Training - Annealing, Hardening, Tempering" is to be distributed among the trainees according to their number and intended as theoretical basis for the exercises to be carried out.

- Starting materials required for the exercises are to be prepared in an appropriate number by means of the material data given in the "Instruction Examples...".

- The workshop is to be checked for a complete equipment with tools, devices and auxiliary means according to the exercises intended.

- Recommended basic outfit:

- smith's hearth with coal shovel, swatter and fire rake, stock of charcoal;**
- muffle furnace with temperature gauge;**
- inserts with sand and charcoal powder filling;**
- melting bath for salt filling;**
- hot bath for oil filling;**
- quenching tanks for water and oil;**

- **hooks, spears, tongs, worn-out files, hammers;**
- **handling devices for small and medium-sized workpieces: sieves and baskets;**
- **cleaning agents: scouring cloths, sawdust, brooms;**
- **additives: clay, paper**
- **quenching media: water - fire-resistant, heatproof lubricating oil;**
- **melting agents: cyanide salts and nitrites.**

The functionality of the devices is to be checked with regard to labour safety and fire protection regulations prior to the beginning of the exercises.

2.4. Planning of Training Phases

Starting from the total hours the periods for the individual training phases of this training unit are to be planned independently from each other.

For the following training phases it is advisable to take a phasing:

- **for the introduction into the working techniques in the form of instructions;**
- **for necessary demonstrations;**
- **for task-related instructions for the preparation of exercises;**
- **for the execution of the exercises;**
- **for recapitulations and control works.**

The following factors are to be considered when planning the periods:

- **the state of training of the trainees;**
- **the conditions of training;**

- **the future employment of the trainees;**
- **the degree of difficulty of the training phases.**

Focal point of each training phase is always the acquisition of mechanical abilities and skills by means of exercises, that feature must be given most of the time.

3. Recommendations for the Execution of the Vocational Training in the Working Techniques "Annealing, Hardening, Tempering"

The following sections include recommendations on how to organize the instructions for the trainees, the demonstrations of the working techniques as well as the exercises and control works.

3.1. The Introductory Instruction

If possible, the introductory instruction is to be carried out in a class room with the trainees. During the instruction it has to be taken into consideration that the trainees shall write necessary supplements or answers to questions in the "Trainees' Handbook of Lessons - Annealing, Hardening, Tempering". The instruction can be carried out with regard to the contents given in the "Trainees' Handbook of Lessons":

Purpose of heat treatment of steel

In the beginning, the trainees are to be made familiar with the term of "heat treatment" as a sequence of various processes of heating and cooling down. They shall realize that tools, measuring and testing devices as well as various machine parts must have special properties which are only reached by a heat treatment

which, however, is to be carried out appropriately.

In this connection, a *demonstration* may be carried out:

A few chisel blows are to be made onto a steel plate of about 4 mm thickness by means of an unhardened flat chisel. Subsequently, this process is to be repeated by means of a hardened flat chisel.

All the trainees shall examine the steel plate and the two flat chisels and draw the necessary conclusions. Subsequently, a broken chisel may be used as an example of an unsuitable heat treatment.

The consideration of the heat treatment of alloy steels is necessary. The term of "alloy steel" is to be explained or recapitulated, the special properties of those steels have to be mentioned.

It must be said that a correct heat treatment can only be carried out if the conditions given by the steel manufacturer are strictly adhered to, therefore, he shall supply tables specifying the appropriate temperature data. If possible, such a table should be shown.

All sections to be dealt with in the following are therefore only to be referred to unalloyed steels!

Types of heat treatment processes

The trainees may be made familiar with the most common heat treatment processes by means of the chart given in the "Trainees' Handbook of Lessons".

Those processes may be explained more in detail by means of the subsequent sections in the "Trainees' Handbook of Lessons".

In addition, the special processes of "surface hardening" and "hardening and tempering" should be mentioned, but it is to be indicated that also other variants and processes are used in industry apart from the processes mentioned.

Devices and auxiliary means for heating, transportation and cooling down of workpieces

The devices and auxiliary means suitable for the production of individual parts or small series are to be mentioned and explained by means of appropriate figures, originals and models:

- smith's hearth with coal shovel, swatter and fire rake, stock of charcoal;
- gas burner to temper and flame hardening;
- Furnaces with and without temperature gauges, equipped with one or more compartments;
- melting baths for metal or salt melts as well as hot oil baths;
- sheet-metal inserts for casehardening with sand and carbon-containing powder filling;
- hooks, spears, tongs;
- handling devices such as self-tightening claws and hangers on lifting devices;
- sieves and baskets;
- quenching tanks for water and oil filling.

The effect of the different quenching media is to be explained by means of the chart in the "Trainees' Handbook of Lessons".

A short exercise of conversions is to be made for temperature data if the unit of "degree centigrade" is not used. The conversion into "Kelvin" and "Fahrenheit" is possible according to the following table:

Centigrade Kelvin Fahrenheit

0°C = 273 K = 32 F
100°C = 373 K = 212 F

Since the Fahrenheit units do not run in the same rate as "Centigrade" and "Kelvin", conversion must be effected by means of a self-made numerical line onto which these units are entered.

Principles and types of annealing, hardening and tempering

In the sections included in the "Trainees' Handbook of Lessons" the essential facts related to the mentioned heat treatment processes have been stated.

The individual principles of the procedures as well as the specific features of application are to be discussed step by step. The questions following the sections should immediately be answered in writing by the trainees and entered in the appropriate free places of the "Trainees' Handbook of Lessons".

Those answers must be checked during the discussion by a comparison!

Wrong answers must not be overlooked!

Annealing:

After definition of the term, the possibility is to be made evident to the trainees on how temperatures may be assessed at workpieces without temperature gauges. As to plain carbon steels, the standard colour values may be imparted by means of the table in the "Trainees' Handbook of Lessons".

Those standard values are only to be applied if no exact temperature gauge is existing at the device to heat the workpiece!

Subsequently, the following processes are to be discussed individually:

- stress-free annealing**
- soft annealing**
- normalizing.**

The importance of a correctly effected annealing process is to be demonstrated to the trainees. They must realize that workpieces become useless or require refinishing when the annealing is not effected correctly and expertly. It must be explained that the adherence to the holding time is vital to reach the desired change in structure.

Therefore, calculations are to be made by means of the rule:

Holding time = 20 minutes plus half of workpiece thickness

The section "Control of the annealing result" should be made clear by suitable illustrative materials of various break samples.

The trainees are to be made qualified to exactly assess the appearance of the break. Subsequently, the trainees shall answer the complex of questions in the "Trainees' Handbook of Lessons".

Hint:

Now, the introductory instruction may already be finished and simple exercises for "annealing" could be carried out. But it is advisable to continue the instruction with regard to "hardening" and "tempering" in order to carry out a complete sequence of exercises by means of the "Instruction Examples for the Practical Vocational Training".

Hardening:

It is recommended to continue the instruction with regard to "hardening" according to the following sequence:

- definition;**
- preconditions for hardening by means of heat treatment as to material engineering;**
- principle of hardening by means of heat treatment;**
- types of hardening by means of heat treatment;**
- hardness-related shaping of the workpieces;**
- hardening defects;**
- specific working hints for practical execution of work;**

- hardness measurement.

After an exact definition it is necessary to mention the material-related preconditions for hardening by means of heat treatment - the trainees must learn that not all unalloyed steels are hardenable, and that is why they must know the carbon content of the workpiece to be hardened!

Subsequently, the three essential hardening processes are to be explained:

- quenching**
- interrupted hardening**
- hot quenching.**

As to the latter process, calculations are to be carried out regarding the holding time in the hot bath. The rule is:

Holding time = Diameter or thickness in mm . seconds/10 mm

The section "hardness-related shaping of workpieces" may be demonstrated by means of illustrative materials showing positive and negative features of shaping. The appropriate figures in the "Trainees' Handbook of Lessons" shall be used for problem discussions.

In the same connection, the discussion on "hardening defects" may be effected, it should not be done without illustrative materials.

As to the work in the workshop, specific practical hints are of special importance. Thus, it is advisable to check the procedures resulting from theory only for their

practical use and to explain them more in detail.

In this connection, the packing of workpieces should especially be dealt with which protects the work-pieces from scaling or carbon loss. Furthermore, possibilities to cover the workpieces having great cross-section differences are to be mentioned.

Point out: It is also important to ensure a preheating of all parts when hardening several parts in order to save time and quicker reach the hardening temperature.

The complex "Hardening" is to be finished with the section of "Hardness measurement".

If there are hardness measuring devices available, now deal with their application; at the same time the formation of the hardness number according to Rockwell (HRC 50) is to be explained. Supplementary, demonstrate the simple hardness test by the file test.

Tempering:

Since this process directly follows the hardening process, it must be discussed subsequently. In this connection, the relation between tempering temperature and certain examples of application is of special importance; a chart in the "Trainees' Handbook of Lessons" shows this fact concerning plain carbon steels.

The connection between tempering temperature and hardness may also be illustrated by means of the following table with regard to a tempering test:

| Tempering temperature | Rockwell hardness |
|------------------------------|--------------------------|
|------------------------------|--------------------------|

| | |
|-------|------|
| 200°C | 63.5 |
| 240°C | 62 |
| 260°C | 60.5 |
| 280°C | 58 |
| 300°C | 56.5 |
| 320°C | 54.8 |
| 340°C | 54 |

A steel was gradually tempered according to the table, and the hardness was controlled each time as to the Rockwell process. It was determined that the Rockwell hardness decreases with increasing temperature, but steel's toughness increases.

The tempering test indicated that the tempering temperatures must be held in very narrow limits. Subsequently, explain the processes of tempering from outside and the tempering from inside.

Hint:

Now, the instruction may be finished and the appropriate exercises will be carried out. The following items as to "surface hardening" and "hardening and tempering" may be imparted in a supplementary instruction given at a later date.

Application of surface hardening and hardening and tempering

The possibilities to harden only the surfaces of workpieces as is possible by means

of "flame hardening" and "casehardening" should be mentioned as specific processes of heat treatment. When explaining those processes, the material-related preconditions (carbon content) must be especially pointed out.

Casehardening is to be demonstrated by means of the term of "carburization", an existing insert with appropriate charge material should be shown as original.

At the end of the instruction, impart "hardening and tempering" as possibility to increase strength and toughness simultaneously in general.

3.2. The Exercises

On principle, the necessary instructions as to labour safety must be given prior to the beginning of the exercises. Then, show the workshop and the existing equipment to the trainees and demonstrate its operation. It is advisable to begin each exercise by a demonstration given by the instructor in connection with an instruction related to the instruction example. Therefore, motivate the trainees to carry out the exercise with good quality. Refer to difficulties which may occur.

The exercise may be effected either thematically completed or in several phases according to the hints given in section 3.

6 exercises can be accomplished for various processes of heat treatment by means of the "Instruction Examples for the Practical Vocational Training".

The material "Instruction Examples ..." includes a list of materials (starting material, tools and devices and auxiliary means) and the sequence of operations to execute the exercises as well as a clearly represented workshop diagram.

Hence, the trainees get all the necessary information for being able to systematically execute the exercises.

If it becomes apparent during the exercises that the quality of the exercise pieces is not sufficient, more extensive exercises must be carried out; in that case, any waste parts should be used. When the skills have been practised enough, the intended instruction example may be produced.

The instructor must already have produced the exercise piece by himself and he must know the problems occurring in its production!

The focal points of rating to estimate the performance may thus be mentioned definitely - problematic points at the exercise piece can be referred to. During the task-related instruction, the "sequence of operations" and the workshop diagrams of the instruction examples should lie on the tables so that the trainees can write comments in their notebooks.

In order to give a general view at which exercise pieces the knowledge previously imparted should be applied, the individual instruction examples have been described in the following in short:

Instruction examples:

Instruction examples 16.1.: assembly tools

A small spiral spring (wire diameter appr. 1.0 mm) is to be made bendable by soft annealing in a smith's hearth. Bend hooks at the ends by means of tongs and,

subsequently, harden and temper the spiral spring again.

(Figure 1)

Instruction examples 16.2.: marking and riveting tools

Prefabricated scriber, centre punch, rivet header and rivet drawer are to be treated from outside by quenching and subsequent tempering. Use the muffle furnace.

(Figure 2)

Instruction example 16.3.: flat chisel and cape chisel

Prefabricated flat chisels and cape chisels are to be treated by quenching and subsequent tempering from inside. The muffle furnace is used.

(Figure 3)

Instruction example 16.4.: assembly tools

Prefabricated hexagon socket wrenches, box wrenches and screw drivers are to be treated by interrupted hardening and subsequent tempering from outside. Any furnace and separated quenching media are used.

(Figure 4)

Instruction example 16.5.: locksmith's hammer

Prefabricated locksmith's hammers are to be treated by hot-quenching and

subsequent tempering from outside. Any furnace and a salt melting bath are used.

(Figure 5)

Instruction example 16.6.: testing means

Prefabricated steel straightedges, back squares and centre squares are to be treated by casehardening and subsequent tempering. A controllable furnace with appropriate insert is used.

(Figure 6)

All trainees can execute the exercises at the same time, if the material preconditions have been guaranteed (enough working means).

In that case, the trainees can execute each individual exercise independently - each trainee should get so much time he needs.

If there are not enough working means available, the trainees must be divided into groups. In this connection, it is advisable to divide these groups according to the use of the various devices:

1st group - work on smith's hearth

2nd group - work on muffle furnace

3rd group - work on any furnace and on melting bath.

If the instruction examples offered will not be used for exercises, it is possible to select other exercise pieces. In this case, it should be taken into consideration that

all the working techniques discussed previously may also be practised on those exercise pieces.

Focal points for practical execution

For the execution of the works it is recommended to determine focal points for examination and estimation. Those focal points may be characterized by the following features:

- Do the trainees carefully prepare their working places?**
- Are the prefabricated exercise pieces clean and dry?**
- Are the devices for heating operated appropriately?**
- Are the correct temperature ranges identified?**
- Are the technological sequences adhered to?**
- Do the trainees adhere to the regulations on labour safety?**

3.3. Examples for Recapitulation and Control

For strengthening and checking the knowledge acquired, tasks have been assembled in this section, the tasks are given together with the appropriate answers. Tasks also included in the "Trainees' Handbook of Lessons" have been marked with the letter "A".

1. What is heat treatment?

"A" (a systematic sequence of heating and cooling)

2. What is the purpose of heat treatment processes?

"A" (change of properties of unalloyed and alloy steels)

- 3. According to which criteria are the heat treatment processes selected?
(according to the purpose of application and the kind of material of the object to be treated)**
- 4. Which are the most common processes of heat treatment?
(annealing, hardening, tempering)**
- 5. Which requirements have to be made on devices for heating the workpieces?
"A" (temperature must be reached quickly, kept constant and must be adjustable without difficulty; steady heating of workpieces has to be ensured)**
- 6. Which devices are used for heating?
(smith's hearth, gas burner, furnaces, melting baths)**
- 7. What is the advantage do of melting baths compared to the smith's hearth?
(temperature is exactly adjustable, no danger of overheating, no scaling of workpiece surfaces)**
- 8. Which requirements have to be made on quenching tanks?
"A" (quenching media must always be kept cool)**
- 9. Which main effects can have quenching media?
(coarse and mild effect)**
- 10. Which effect has the use of a coarse quenching medium onto the workpiece?
"A" (great strength and hardness, especially at the case, little elasticity)**
- 11. Which requirements have to be made on the workpieces being prepared for the**

annealing process?

"A" (they must be clean, rust-free and free of scale)

12. What principle is the basis for annealing?

"A" (heating of the workpiece and holding of annealing temperature over a certain period, subsequently, slow cooling down)

13. What is the purpose of stress-free annealing?

"A" (elimination of stresses existing in the prefabricated workpiece)

14. What is the purpose of soft annealing?

"A" (makes farther working processes for hardened or carbon steels possible)

15. What is the purpose of normalizing?

"A" (equalization of irregularities in the steel structure, achieving a fine-grained structure)

16. Which rule has to be heeded for holding massive workpieces at annealing temperature?

(20 minutes plus half of material thickness)

17. Which holding time has to be considered when a shaft of 84 mm diameter must be annealed?

"A" (62 minutes)

18. Acc. to which criteria are annealing defects evaluated?

"A" (according to the appearance of the broken workpiece)

**19. Which annealing faults may be deducted from a coarse-grained structure?
"A" (steel was heated too long or at a too high temperature)**

**20. What is the purpose of hardening by means of heat treatment?
"A" (to make steels hard and wear-resistant for certain purposes)**

**21. Which minimum carbon content must have a steel for being hardened?
"A" (0.35% of carbon)**

**22. Which effect has a higher carbon content on the mechanical properties?
"A" (great hardness and strength, little toughness and elasticity)**

**23. Which working steps are required for hardening?
"A" (heating to hardening temperature, holding and sudden cooling down of the workpiece)**

**24. What hardening temperature has to be chosen for an unalloyed steel of 0.8% carbon content?
(780°C)**

**25. What is the characteristic feature of interrupted hardening?
"A" (quenching is effected for a short time, in most cases first in a powerful and then in a mild quenching medium)**

**26. A workpiece having irregular shapes shall be hardened by hot-quenching. Its average thickness is 100 mm. Which time has to be met in the melting bath during the cooling-down process?
(600 seconds or 10 minutes, respectively)**

**27. What has to be considered when dipping the workpieces into melting baths?
(correct dipping according to shape, only dip dry workpieces)**

**28. Why it is advisable to harden workpieces in a carbon-containing packing?
"A" (workpiece cannot be scaled and absorbs carbon, thus avoiding carbon loss at high heat effect)**

**29. What is a simple way to test hardness?
"A" (by a file test; if the file is slipping, the workpiece is harder than the file)**

**30. What is the purpose of tempering?
"A" (to give the workpiece a useful hardness after hardening)**

**31. What effect has the tempering temperature on useful hardness?
"A" (the higher the tempering temperature, the smaller the hardness)**

**32. Why can temper colours facilitate temperature determination?
"A" (a thin oxide layer inking according to temperature is produced when heating a blank steel)**

**33. Which properties can reach workpieces after surface hardening?
"A" (the workpieces withstand great impact and bending stresses by hard surfaces and a tough core)**

**34. Which steels can be treated by flame hardening?
"A" (unalloyed steels of 0.35% to 0.6% carbon content)**

35. Which steels can be treated by casehardening?

"A" (tough steels of a carbon content below 0.25%)

36. Which properties shall be reached by hardening and tempering?

"A" (at relatively high strength values, a great toughness shall be guaranteed continuously)

4. Explanations to the Means of Instruction

Apart from models and originals of devices and auxiliary means, break samples of heat-treated workpieces are recommended as additional illustrative material. The following samples should be manufactured:

- steel of little carbon content**
- steel of high carbon content**
- steel having been heated too long or at a too high temperature**
- steel having been heated extremely high so that it is already burned**
- hardened and broken flat chisel.**

Furthermore, examples for good and bad manufacture should be produced by means of the figures included in the "Trainees' Handbook of Lessons". Those examples will show envisaged affects after hardening (cracks).

Existing defects should be made visible by a paint coat on a workpiece having cracks.

For demonstrating the annealing colours, a table of colours including the appropriate colours is recommended which can be made as blackboards charts.





[Home](#) > [ar](#).[cn](#).[de](#).[en](#).[es](#).[fr](#).[id](#).[it](#).[ph](#).[po](#).[ru](#).[sw](#)



 **Manual Working of Material/Metal - Course: Manual working of metal. Methodical course-guide for instructors (Institut fr Berufliche Entwicklung, 120 p.)**

 *(introduction...)*

  **Introduction**

-  **1. Aims and contents of the course**
-  **2. Organizational preparation of training**
- 3. Accomplishment of the training**
 - Chipping**
 - Riveting**
 - Grinding of Simple Tools**
 - Shearing**
 - Bending**
 - Straightening**
 - Annealing, Hardening, Tempering**

Introduction

The present guide shall help the instructor to accomplish the practical Locational training by giving practical recommendations as to the

- **preparation,**
- **accomplishment and**
- **review of the practical vocational lessons.**

At the beginning of the methodological guide the instructor is informed of the aims and contents of the course. The guide also states the previous knowledge required for acquiring the working techniques of machining of material. The emphasis is on the recommendations of didactic and methodology of the practical vocational lessons. The recommendations suggest the instructor how to plan and prepare the lessons. Possible forms and methods of accomplishing the instructions and exercises are also explained.

The last section deals with the peculiarities of the individual training units. It also contains a summary of the necessary teaching aids and working tools to facilitate organizing the course.

A methodically arranged complex of questions and answers shall help the instructor to test the know ledge of the trainees.



Home > [ar.cn.de.en.es.fr.id.it.ph.po.ru.sw](#)

 **Manual Working of Material/Metal - Course: Manual working of metal. Methodical course-guide for instructors (Institut fr Berufliche Entwicklung, 120 p.)**

 **(introduction...)**



- ➔ **Introduction**
- 1. Aims and contents of the course**
 - 2. Organizational preparation of training**
 - 3. Accomplishment of the training**
 - Chipping**
 - Riveting**
 - Grinding of Simple Tools**
 - Shearing**
 - Bending**
 - Straightening**
 - Annealing, Hardening, Tempering**

1. Aims and contents of the course

On completion of this training course the trainees should have the necessary knowledge, abilities and skills to work with

- **engine lathes,**
- **horizontal or vertical milling machines,**
- **horizontal shaping machines and**
- **boring/drilling machines.**

This implies that the trainees

- **are able to decide on the purpose and application of the relevant machine and technique,**

- **are capable of setting up, operating, servicing and maintaining the machines and know the construction of the machines,**
- **have knowledge of how to determine the cutting values, such as speeds, feeds and stroke length.**
- **are able to select the proper tools and accessories for setting up the machines and know the construction of the different types of tools and accessories,**
- **have knowledge of how to meet the safety requirements in machining of material.**

The course comprises the following training units (TU):

1st TU: Chipping

2nd TU: Riveting

3rd TU: Grinding of Simple Tools

4th TU: Shearing

5th TU: Bending

6th TU: Straightening

7th TU: Annealing, Hardening, Tempering

To successfully acquire the skills of these working techniques, the trainees must have previous knowledge of and master the basic skills in the working techniques of manual working of material. In addition, they should have basic knowledge of engineering drawing to be able to "read" the working drawings.



[Home](#) > [ar](#).[cn](#).[de](#).[en](#).[es](#).[fr](#).[id](#).[it](#).[ph](#).[po](#).[ru](#).[sw](#)



 **Manual Working of Material/Metal - Course: Manual working of metal. Methodical course-guide for instructors (Institut fr Berufliche Entwicklung, 120 p.)**

 **(introduction...)**

 **Introduction**

 **1. Aims and contents of the course**

  **2. Organizational preparation of training**

3. Accomplishment of the training

Chipping

Riveting

Grinding of Simple Tools

Shearing

Bending

Straightening

Annealing, Hardening, Tempering

2. Organizational preparation of training

In order to ensure that the instructions, demonstrations and exercises go off smoothly, the training must be well prepared. The following is to be made available:

Classroom and workshop

Though the instructions could be given in the workshop, it is better to do it in a room where the trainees have adequate facilities to sit and write.

If a daylight projector shall be used, a bright projection area and electric supply are required.

The demonstrations of the working techniques, followed by exercises, are to be done in the workshop directly on the relevant machine. One machine with the necessary cutting and operating tools, measuring and testing tools and accessories should be available for each trainee. The necessary working tools, related to the "Instruction Examples for Practical Vocational Training", are summarized in the "Methodical Guide for Instructor".

Teaching aids

Sufficient copies of the "Trainees' Handbook of Lessons" equalling the number of trainees are to be made available. The "Trainees' Handbook of Lessons" is mainly used in the introductory instruction for introduction and recapitulation. It explains the technical knowledge of one training unit, which is absolutely necessary for mastering the relevant technique, in a clearly arranged and easily conceivable way. Many illustrations add up to better understanding. Tasks and questions are included to recapitulate, strengthen and test the knowledge acquired. But they may also be used by the trainees for acquiring the knowledge by themselves. A summary of all questions is contained in a complex of questions and answers in the present methodical guide in the sub-section of the relevant training unit. Tasks and

questions included in the "Trainees' Handbook of Lessons" are marked with "A".

Sufficient copies of the "Instruction Examples for Practical Vocational Training", depending on the number of trainees, are to be made available. They explain the technology for practising the examples, supplemented by working drawings. By means of the "Instruction Examples ..." workpieces can be produced and working algorithms practised to develop essential practical skills. Based on the "Instruction Examples ...", the availability of the materials and necessary working tools can be checked and arranged by the trainees themselves.

The "Instruction Examples ..." of each training unit are arranged with increasing level of difficulty and should be followed in the sequence given. The textbooks

- "Basic Vocational Knowledge - Working of Metal"**
- "Formulas and Tables - Metal"**
- "Machine Elements and Assemblies and their Installation"**

can be used by the instructor for the instructions to consolidate knowledge and refresh basic knowledge.

The textbook "Formulas and Tables - metal" is particularly recommended for exercises of technical calculations.

All tools and accessories required for the working technique are to be made available as visual and/or demonstration aids. Various workpieces related to the conditions of the relevant factory are also to be made available for demonstration.

If transparencies shall be used, the daylight projector is to be checked for

serviceability and the transparencies are to be checked for completeness. It is recommended to use the series of transparencies "Machining of Material" consisting of 37 transparencies (see "Methodical Guide for Instructor").

Blackboard drawings are to be prepared prior to the instructions.

If further teaching aids are available, the instructor can complete the "Methodical Guide for Instructor". This will give him a comprehensive survey and facilitate the preparations for the instructions.

Working tools and materials

The trainees' working places are to be checked for neatness, serviceability and completeness of the working tools and materials.

The completeness of the required technological documents (drawings, instruction examples for the relevant working technique) is to be ensured. Tests and/or recapitulations are to be prepared. The materials required for the exercises are specified in the relevant "Instruction Examples for Practical Vocational Training" - including the required dimensions. In a few cases the raw materials are to be made available in a certain stage of prefabrication that is to be prepared on advance.



Home"" """"""> [ar.cn.de.en.es.fr.id.it.ph.po.ru.sw](#)



Manual Working of Material/Metal - Course: Manual working of metal. Methodical course-guide for instructors (Institut fr



Berufliche Entwicklung, 120 p.)

- ➔ □ **3. Accomplishment of the training**
 - 📄 **3.1. General recommendations for the procedure of the course**
 - 📄 **3.2. Introductory instruction**
 - 📄 **3.3. Exercises with accompanying instructions**
 - 📄 **3.4. Final instruction**

Manual Working of Material/Metal - Course: Manual working of metal. Methodical course-guide for instructors (Institut für Berufliche Entwicklung, 120 p.)

3. Accomplishment of the training

3.1. General recommendations for the procedure of the course

The training course proceeds in the succession of the individual training units. The training units "Setting up and operation" should always be started with, since they will impart the basic knowledge required for the other training units. The training should then proceed with the training units according to the serial number of the training units. The knowledge and skills in the relevant working technique should be taught by an alternation of instructions and exercises. The instructions shall teach the knowledge required for accomplishing the working technique. In the exercises to follow the trainees shall put into practice the theoretical knowledge acquired. Practising of the work routines should take most of the time available for training and go on until a specified level of perfection has been reached. The practical

exercises are to be considered the heart of the training. At the end of the exercises each trainee should be informed of the level of skills developed. Therefore, the following procedure of teaching a working technique is recommended to the instructor:

- introductory instruction,**
- exercises with accompanying instructions,**
- final instruction.**

3.2. Introductory instruction

This lesson shall teach the theoretical knowledge required for the relevant working technique. It is to be given by the instructor at the beginning of each training unit. After that instruction the trainees should be able to carry out the exercises properly and with as good results as possible.

Related to the individual training units, the whole group of trainees is to be informed of

- the purpose and meaning of the relevant working technique,**
- the construction, maintenance, types of machines, cutting tools, clamping tools, measuring and testing tools,**
- the technological flow of work on the respective machine in the relevant working technique.**

The instruction should also include labour safety instructions. This is absolutely

necessary before each exercise is started in order to avoid accidents. The labour safety instructions should be as vivid as possible explaining accidents and incidents that actually happened in the factory. The trainees should be informed of general rules of labour safety and be referred to further specific hints to be given during the practical work. The trainees must be convinced that accidents cannot be avoided unless the labour safety instructions are strictly followed. A control book is to be prepared to give proof of labour safety instructions given outlining in brief the hints and explanations given to the trainees. Each trainee has to sign in the control book the labour safety instructions for ready reference in the event of any neglect.

General rules of labour safety:

- Wear close-fitting clothes! Loose clothes may be caught and pulled about by rotating machine parts.**
- Never work at machines without protective headgear!**
- Protect your feet by solid footwear!**
- Never remove any protective devices from the machine!**
- Do not reach into rotating machine parts! Switch off the machine first!**
- Use tools in proper condition only!**
- Clamp workpieces and tools safely and firmly!**
- Use safety goggles (particularly with short-chip material) to avoid injuries**

of the eyes!

- **Do not remove metal chips by hand! Use a chip hook, chip brush or hand broom!**
- **Keep naked hands off workpieces with burrs! Use protective gloves or a piece of cloth!**
- **Cover with sand and remove any oil slicks resulting from oiling of the machine!**
- **Never do any measuring or testing unless the machine is at rest!**
- **Do not set the speed or operate any switches unless the machine is at rest!**
- **Do not open any gear or motor covers until after switching off the main switch!**

The introductory instruction may have the form of a lecture or dialogue or combination of these two forms.

The lecture by the instructor shall introduce the trainees into the new working technique and inform them of the aim of the instruction. Moreover, this is a way of teaching unknown knowledge, such as of the construction and operation of the relevant machine, of the construction and type of working tools to be used.

For more vividness of the lecture it is necessary to show and explain, e.g. to demonstrate, all working tools to the trainees. The construction and operation of

the machine should be demonstrated in the workshop directly on the respective machine, the engine lathe, for example. The following steps are recommended for the demonstration of a working process:

- **Demonstration at normal pace of work.**

The instructor mentions the individual steps of work. The trainees get an idea of the entire process.

- **Demonstration at decelerated pace**

The process is disassembled into single components with the emphasis being on explanations.

- **Repetition of difficult steps.**
- **Demonstration of the entire process at normal pace of work.**
- **One or two trainees repeat the demonstration of the working process.**
- **Evaluation of the demonstration.**

It is important that all trainees can match the demonstration.

The lecture by trainees should be used as a means of recapitulating and consolidating knowledge already taught. For this purpose the trainees should be requested to deliver a continuous lecture, e.g. about the construction of vertical and horizontal milling machines.

The teaching dialogue shall serve to jointly elaborate (instructor with trainees) new knowledge, e.g. of technological processes. The dialogue is based on existing knowledge which is to be applied to new situations. For example, the dialogue may be preceded by reading some sections in the "Trainees' Handbook of Lessons".

The elaboration of new knowledge in the dialogue can be considerably supported by the use of various visual aids, such as original cutting, clamping, measuring and testing tools, of the illustrations in the "Trainees' Handbook of Lessons", of transparencies and models. It is recommended to use the series of transparencies "Manual Working of material" which can be applied for every training unit (see "Methodical Guide for Instructor"). The dialogue may also be used as a means of recapitulating known knowledge. All trainees can be involved in the recapitulation by the form of questions and answers of the dialogue. So the instructor can easily judge the level of knowledge of the trainees. The questions contained in the "Trainees' Handbook of Lessons" should be included in the teaching dialogue. Immediately upon elaboration of one or more key points, the trainees may be requested to answer orally or in writing. In this way, the instructor can find out whether or not the trainees have understood everything. On the other hand, the questions in the individual sections of the "Trainees' Handbook of Lessons" are a means of control if the trainees had been requested to elaborate some technical key points on their own.

3.3. Exercises with accompanying instructions

Immediately before any exercises the trainees should be given specific hints for the workpiece to be practised.

According to the individual instruction examples, the trainees should be provided with information

- on the aim of the exercise,
- on the raw material of the workpiece,
- on the cutting, clamping, measuring and testing tools and accessories immediately required,
- on the steps of work (difficult steps should be demonstrated again),
- on certain dimensions and critical points of the workpiece,
- on criteria for judging the performance at the workpiece and on intermediate controls.
- on the time of the exercise to be kept.

A finished workpiece should be shown to the trainees to make clear the aim and key points of the exercise. It is useful when the instructor has previously made the workpiece himself so as to know the problems connected with its manufacture.

So he can clearly state the performance rating criteria and point out critical points of the workpiece. During such instructions each trainee should have the sequences of operations and the working drawings of the "Instruction Examples for Practical Vocational Training". The trainees may then add necessary hints under headline "Comments" of the "Instruction Examples...".

The aim of the exercises is to learn and to develop the skills of important operations in machining of metal workpieces up to an intended level of perfection. Therefore, the exercises must be repeated several times and be carried out purposefully. If the instructor is of the opinion that the first example of any training unit would make

too high demands on the trainees' skills, preparatory exercises must be planned in terms of time and availability of material. Such preparatory exercises could comprise:

- Practising of the manipulation for setting up and operating the machines without workpieces.**
- Practising of the possibilities of clamping of any blanks desired.**

It is also possible to start immediately with the exercises based on the "Instruction Examples for Practical Vocational Training". If the "Instruction Examples for Practical Vocational Training" offered are not used for the exercises, it is also possible to select other workpieces. In this case, attention should be paid to the fact that the workpieces selected lend themselves to practising of all working techniques already discussed. Before the trainees start practising, the instructor should make sure that the labour safety instructions and the instructions on how to behave in the workshop have been given. If not, they should be given now. For the exercises on lathes, the existing engine lathes should be assigned to the trainees according to their body height. The height of the machine can be compensated by footboards (gratings).

Upon assignment of the working places to the trainees including checking for completeness and serviceability of all cutting, measuring, testing tools and accessories, the trainees should receive their material. Each trainee should produce his workpiece himself, from cutting the blank until completion of the part. This is the only way of fair rating of the trainee's performance. The performance rating criteria are to be made known to the trainees before they start with the exercises. Each trainee should start practising based on the sequences of operations and

working drawings.

All trainees should carry out the exercises on the same workpiece in the same sequence!

In this way the instructor keeps control of things. In the event of any difficulties the instructor must find out whether they face individual trainees only or the whole group. Individual trainees may be guided individually. If the whole group is facing the difficulties, the exercises should be interrupted for additional hints to be given to all trainees. The instructor should always walk from one trainee to another one to get exactly informed of the state of machining. He should praise good results and criticize bad results.

The instructor must always keep control of things.

The trainees must not practise unsupervisedly.

If the instructor finds out that the working techniques are carried out wrongly, he must make corrections immediately.

Since the trainees are working with machines, special attention is required. The trainees must not operate the machines unless they have first been instructed in the operation or the controls and in the hazards of injuries. One trainee only should work at the machine at a time.

In the event of waiting times because of occupied machines it is useful to keep the trainees busy with intermediate jobs, such as

- **sharpening of worn-out cutting tools,**
- **repair of damaged working tools,**
- **refilling of coolant and lubricant.**

With increasing level of intricacy of the exercises intermediate controls are recommended. This is an opportunity for the instructor to rate the performance already prior to the completion of the exercise. Workpieces of bad workmanship can be eliminated already in this stage if reworking is required or a good final result cannot be expected any more. This is all the more important if single parts are to be matched and one part cannot be made fit because of poor quality of machining.

It is a waste of time if trainees continue machining of parts which are of no use.

In this case it is more useful if the trainee stops the exercise and starts again with new raw material.

Intermediate controls, which are announced to the trainees in advance, stimulate the trainees and make them feel confident to go on with the exercises.

The instructor should note down the results and observations of the intermediate controls to take them into account for the final control.

Upon completion of each exercise the workpiece must be rated.

It is important that the rating is based on the rating criteria stated before the beginning of the exercise.

In preparation of the control and evaluation of the results the instructor must

ensure that

- each trainee is informed of the rating criteria,
- a sheet of paper is prepared to fill in the results of rating.

Experience showed that the trainees are stimulated by seeing and comparing their performances on a rating sheet visible for anybody.

This rating sheet may have the form of a clearly arranged table:

Table 1: Example of a rating chart

Training unit 1

| | 1st instruction example | | | 2nd instruction example | | | 3rd instruction example | | |
|------------------------|---|-----------------------|-------------------------|---|-----------------------|-------------------------|---|-----------------------|-------------------------|
| Rating criteria | accuracy to size | surface finish | time of exercise | accuracy to size | surface finish | time of exercise | accuracy to size | surface finish | time of exercise |
| 1 st name | | | | | | | | | |
| 2 nd name | | | | | | | | | |
| 3 rd name | | | | | | | | | |

The rating sheet should be open to inspection by all trainees. During the controls,

whether intermediate or final, the trainees should have the opportunity of self-assessment of their performance. In this way, the trainees learn to exercise self-control. Observations and results of the intermediate controls noted down during the exercises are to be taken into account for the rating. Irrespective of the form of rating (mark, point or percentage system), general rules of rating the quality of the workpieces and the way of working are to be observed. The following rules of rating are recommended:

Very good performance

The workpiece is faultless. All specified sizes have been complied with. The workpiece surfaces are clean. Full use of the workpiece is ensured. The workpiece has been produced within reasonable time and with no additional help by the instructor. The trainee has a good command of the working techniques and properly uses the tools and accessories.

Good performance

The workpiece shows minor faults in terms of compliance with specified sizes and cleanness of the workpiece surfaces. The use of the workpiece is ensured. No reworking is required. The trainee basically works on his own. With certain reservations the trainee has a good command of the working techniques.

Fairly good performance

The workpiece shows several faults which can be removed by reworking, such as deviations from specified sizes, unclean surfaces. The use of the workpiece is ensured.

The trainee works with little help. He has no good command of the working techniques.

Satisfactory performance

The workpiece shows major faults in terms of accuracy to size and quality. It can just be used. Reworking is necessary.

The trainee needs the help of the instructor because he has a poor command of the working technique and does not always find faults himself.

Unsatisfactory performance

Specified sizes have not been complied with. The workpiece is of no use. The trainee is not able to work on his own. He has no command of the working techniques.

3.4. Final instruction

At the end of each exercise and immediately on completion of each training unit the results must be evaluated. Such evaluation should have the form of discussions with the whole group of trainees to find out:

To which degree did each trainee achieve the aims envisaged? It is recommended to guide the trainees, based on the rating criteria made known before the exercise, to assess their results themselves. The instructor should

- complete the trainees' assessment,**

- rate the results,
- generalize the experience gathered by the trainees,
- point out typical faults made by the trainees in their work and the causes,
- show to the trainees ways of removing and avoiding faults in preparation of the next exercise.

The results of the evaluation should be recorded in a table (see table 1). At the end of a training unit it is useful to have a prepared test. In this may the instructor will get a comprehensive survey of the trainees' knowledge actually acquired and of their practical experience. The complex of questions and answers of each training unit facilitates the preparation and evaluation of such tests.







[Home](#) > [ar](#).[cn](#).[de](#).[en](#).[es](#).[fr](#).[id](#).[it](#).[ph](#).[po](#).[ru](#).[sw](#)



 **Manual Working of Material/Metal - Course: Manual working of metal. Methodical course-guide for instructors (Institut fr Berufliche Entwicklung, 120 p.)**

  **Chipping**

-  **1. Objectives and contents of practical vocational training in the working technique of "Chipping"**
-  **2. Organizational preparations**
-  **3. Recommendations for practical vocational training in the working technique of "Chipping"**
-  **4. Application of the working technique of "Chipping"**



5. Captions and legends of the "Chipping" transparencies series

Manual Working of Material/Metal - Course: Manual working of metal. Methodical course-guide for instructors (Institut fr Berufliche Entwicklung, 120 p.)

Chipping

1. Objectives and contents of practical vocational training in the working technique of "Chipping"

By concluding their training, the trainees shall have a good command of the working technique of "Chipping". Therefore, the following objectives have to be achieved:

Objectives

- Knowledge of purpose and application of chipping.**
- Proper command of the various working techniques of chipping and capability of separating or, resp., cutting workpieces.**
- Capability of selecting the appropriate tools and accessories and of using them appropriately.**
- Capability of making decisions on quality independently.**

The following contents have to be imparted to the trainees:

Contents

- **Purpose of chipping**
- **Tools, accessories and means of protection for chipping**
- **Action and working techniques of chipping**

2. Organizational preparations

In order to guarantee a trouble-free development of the instructions, exercises and practical work it is necessary to prepare this training properly. The following steps have to be taken:

2.1. Preparations for instructions on labour safety

Prior to the exercises the trainees have to be given a brief instruction on the proper use of tools and equipment. This comprises also hints for accident-free work.

The following points should be emphasized:

- **Use proper hammers and chisels only!**
- **Chisel heads must be free from burrs!**
- **Protect your hands from accidents by providing the chisel with an impact guard (cover)!**
- **Wear safety goggles to protect your eyes from injuries!**
- **Enclose your workplace in the direction of impacts by means of protective gratings or protective screens.**

Familiarity with these hints has to be confirmed by the trainees signatures in a control book.

2.2. Provision of teaching aids

- For demonstration purposes during the instructions a vice should be installed at the place of instruction.**
- The "Trainees' Handbook of Lessons - Chipping" is to be handed out to the trainees in sufficient numbers.**
- When using the transparencies series of "Chipping", check whether they are complete (transparencies nos. 10.1 - 10.5.) and whether the overhead projector is in working order. (Check the operating conditions at the place of instruction and make sure of the proper mains supply!)**
- Surveys etc. which have to be written on the blackboard must be completed prior to the instruction.**
- All the tools and accessories for chipping mentioned in section 3 should be kept ready for illustration purposes.**

2.3. Provision of working tools and materials

- Sufficient copies of the "Instruction Examples for Practical Vocational Training - Chipping" must be handed out to the trainees to provide them with the theoretical foundations for the exercises to be carried out.**

- **The initial materials required for the exercises must be prepared and laid out in sufficient numbers on the basis of materials mentioned in the "Instruction Examples ...".**
- **Each trainee is to be provided with a workbench at which a vice, the required steel supports and good lighting are available.**
- **The instructor has to check whether the workbenches of the trainees are fully equipped with tools and accessories necessary for the planned exercises.**

Recommended basic equipment:

- **steel rule, protractor, depth gauge, vernier caliper**
- **steel scribe, prick-punch, double-point punch**
- **hammer, hand hacksaw**
- **flat chisel, cape chisel, half-round grooving chisel, mortise chisel**
- **bastard and smooth files - 300 mm (flat)**
- **C-clamps**

Bench- or column-type drilling machines and the required clamping tools (machine vice, holding clamps, C-clamps) must be provided for the necessary preliminary work (drilling) in some of the exercises.

Based on the regulations on labour safety, the instructor has to check that the drilling machines are in good working order prior to the exercises.

2.4. Time schedule

Time planning is recommended for the following training stages

- **introduction to the working techniques in the form of instructions**
- **necessary demonstrations**
- **job-related instructions to prepare the exercises**
- **carrying out the exercises**
- **recapitulations and tests.**

The necessary time share depends on the respective training conditions. The biggest time share must be allocated to the exercises.

3. Recommendations for practical vocational training in the working technique of "Chipping"

The following paragraphs comprise proposals on conducting trainee instructions, demonstrations of working techniques, exercises and tests . Two course variants are recommended:

Variant no. 1

This variant should be chosen for trainees with generally good achievements and receptiveness.

1.1. Introductory instruction for the whole subject, with demonstrations based on the "Trainees' Handbook of Lessons".

1.2. Exercises in chiselling based on the "Instruction Examples 10.1. - 10.5." with subsequent evaluation.

1.3. Final test of theory knowledge based on the "Examples for recapitulation and tests".

Variant no. 2

This variant should be chosen for trainees with little previous knowledge or poor achievements.

2.1. Introductory instruction with demonstrations based on the "Trainees' Handbook of Lessons"

2.2. Exercises in cutting-off chipping based on the "Instruction examples nos. 10.1. - 10.3." with subsequent evaluation.

2.3. Additional instruction in the working technique of chipping chiselling.

2.4. Exercises in cutting-off and chipping chiselling based on the "Instruction examples 10.4. and 10.5." with subsequent evaluation.

2.5. Final test on theory knowledge based on the "Example for recapitulation and tests"

Practical skills should be checked immediately after handing over the finished workpieces. Theory knowledge can be checked constantly, however, it is recommended to have a final test written (item 1.3. to 2.5.) after the exercises.

3.1. Introductory instruction

If possible, this instruction should be conducted in a classroom. Make sure that the trainees put down necessary and supplementary notes or answers to questions in their "Trainees' Handbook of Lessons".

The instruction can be given based on the main points contained in the "Trainees' Handbook of Lessons".

Purpose of chipping;

The trainees have to learn that cutting-off and chipping by chiselling are energy and time-consuming activities. The instructor has to give examples of such cases where it will not be possible to employ machining techniques and where, therefore, chipping is required.

Based on the transparencies nos. 10.1. and 10.2. the instructor can describe the positions and actions of chisels.

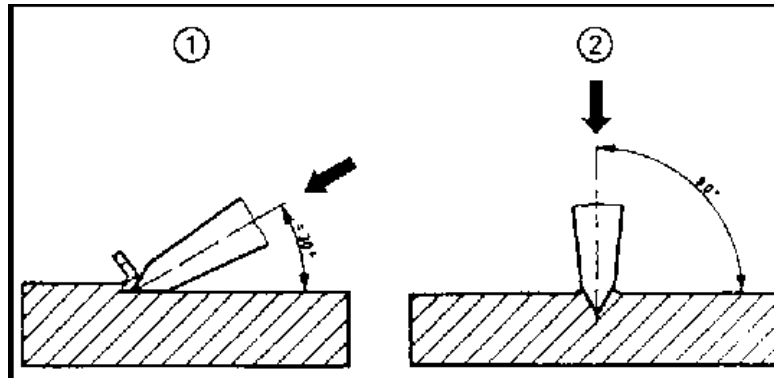

Figure 10.1

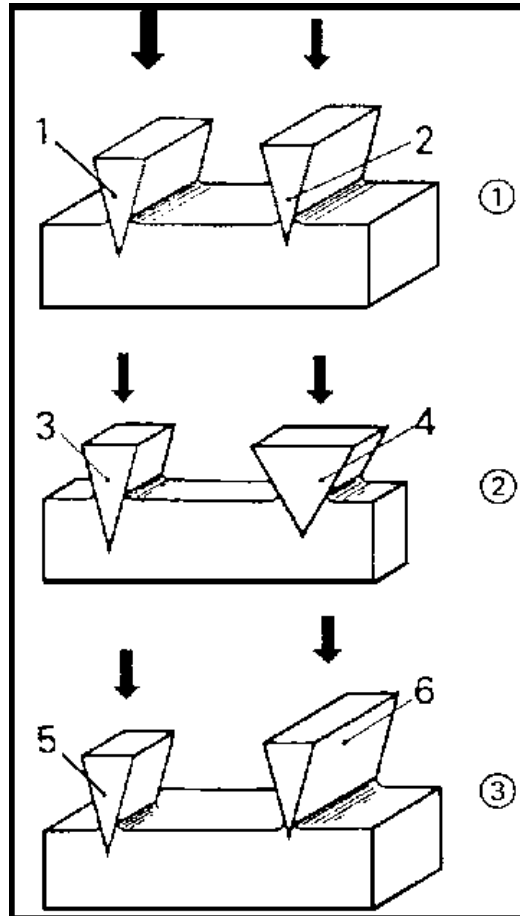

Figure 10.2

Tools, accessories and protective means for chipping:

The following original tools should be shown and the instructor has to explain when to use them:

- **flat chisel (chipping chisel)**
- **round chisel**
- **cape chisel**
- **shear chisel**
- **grooving chisel**
- **mortise chisel**
- **punching tool**

If it is not possible to show all the chisels as original tools, transparency no. 10.3. can be used as a teaching aid. The respective illustrations are also contained in the "Trainees' Handbook of Lessons".

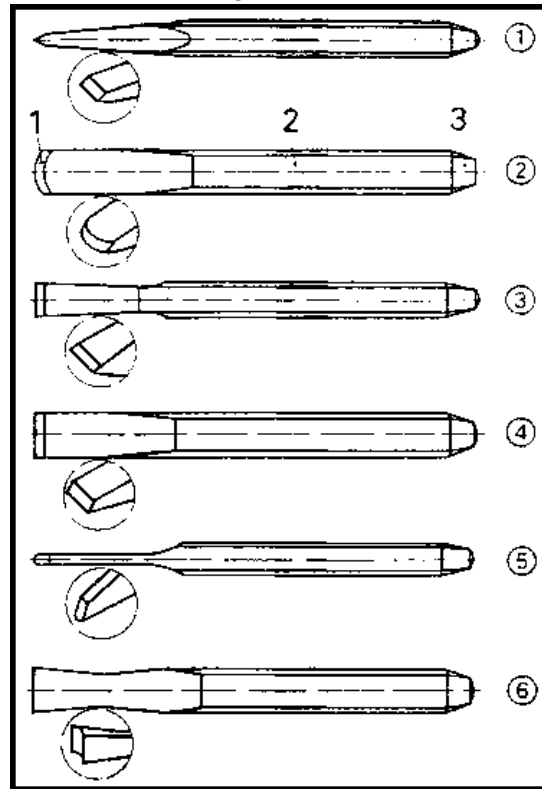

Figure 10.3

When explaining the kinds of chisels the instructor has to mention how chisels are ground.

This includes a description of the relation between the wedge angle of the tool edge and the material properties:

| material property | wedge angle |
|--------------------------|--------------------|
| soft (aluminium) | 30° - 50° |
| medium-hard (steel) | 60° |
| hard (tool steel) | 60° - 70° |

Other tools and accessories to be mentioned are:

- locksmith's hammer
- supports (steel plates and blocks, anvil)
- vice.

The instructor has to stress that surface plates must never be used as a support, because the chisel edge would destroy the surfaces of the plates. The following means of protection should be mentioned:

- protective gratings and screens
- safety goggles and impact protection

Action and working techniques of chipping:

This subject can be clearly explained by using transparencies nos. 10.1. and 10.2. as teaching aids. The instructor has to deal in detail with handling the chisel when chipping and cutting-off. This instruction can be supported by the hints contained in

the "Trainees' Handbook of Lessons" and the respective illustrations, as well as by using transparencies nos. 10.4. and 10.5. as teaching aids.

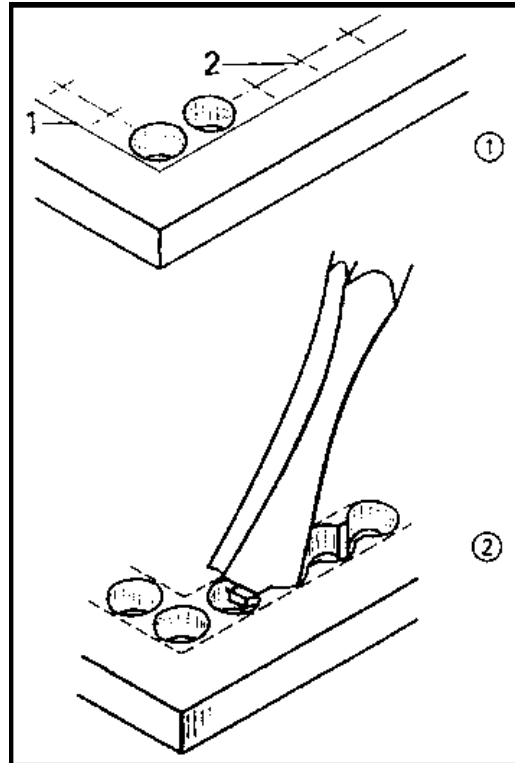

Figure 10.4

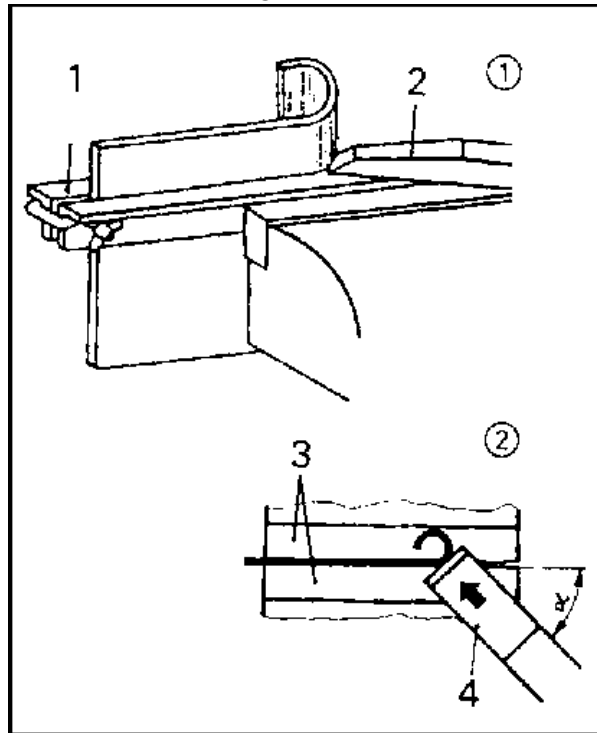

Figure 10.5

If possible, the instructor has to give a demonstration of chipping and cutting-off chiselling on small-size steel parts. When speaking about cutting-off chiselling of curved contours the instructor has to refer to the preparation of this work by scribing a bore line. He has also to refer to the necessary formulae, and a

calculation should be done using the available widths of a double-point punch.

$$D = y - 0.2 \text{ mm}$$

$$x = D/2 + 0.5 \text{ mm}$$

D = diameter of drill

y = width of double-point punch

x = distance of bore line from scribed line

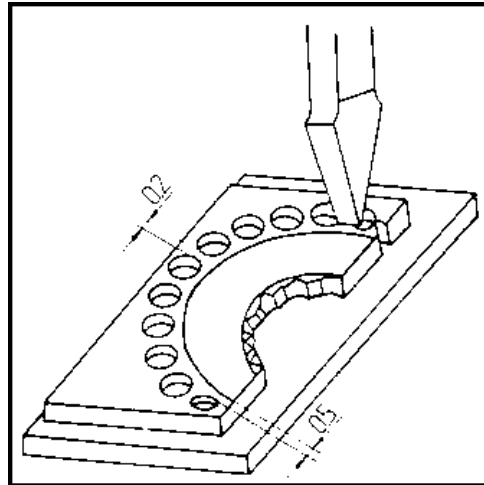

Drilling and chiselling out of curved contours

3.2. Exercises

If it has not been possible to include demonstrations in the instructions, this should be done right now prior to the exercises.

Subsequently, the trainees can begin with their first exercises based on the "Instruction examples for practical vocational training".

However, it is necessary to prepare every individual exercise by a brief "job-related instruction" in the course of which the trainees are shown a finished workpiece in order to demonstrate the objectives and purpose of the exercise.

The instructor must have made such a workpiece himself in order to be familiar with all the problems which might arise from producing such a workpiece.

Thus, the main points of evaluating the achievements can be clearly defined, and the instructor can inform about difficult areas in the exercise. During these instructions the sequences of operations and the working drawings should be placed on the desks so that the trainees can put down additional notes therein. All the trainees can perform these exercises simultaneously, provided that the necessary tools etc. are available. In this case the trainees can carry out all the individual exercises by themselves. Each trainee should be given as much time as required.

If there are not enough tools available, the instructor has to form groups of trainees. It is recommended to divide these groups on the basis of applying the various kinds of chisels:

group no. 1 - working with flat chisels only

group no. 2 - working with flat, cape and grooving chisels.

If there are still trainees who cannot take part in these exercises, they should perform additional exercises to consolidate working techniques acquired earlier.

3.3. Examples for recapitulation and tests

This section comprises questions which are to consolidate and test the previously acquired knowledge and skills. Each question is provided with the respective answer. Questions which are also contained in the "Trainees' Handbook of Lessons" are marked with the letter "A".

1. What is the purpose of chipping?

(Cutting-off or chipping of material.)

2. When do we employ the chipping technique?

"A" (If it is not possible to employ mechanical techniques or if these are too costly.)

3. What is the material chisels are made of?

"A" (Unalloyed tool steel with hardened cutting edge.)

4. What are the criteria for selecting chisels?

"A" (The criteria are: kind of work and hardness of material of the workpiece.)

5. What kinds of chisels do we know?

(flat, round, cape, shear, grooving, mortise and punching chisels (tools).)

6. What is the purpose of using flat chisels?

"A" (Flat chisels are the most common tools for cutting-off and chipping chiselling)

7. What is the purpose of using cape chisels?

"A" (They are used for cutting out horizontal grooves and for cutting-off the webs in bore lines.)

8. What is the recommended wedge angle of cutting edges for working on medium-hard steel?

"A" (60°)

9. Which additional tools and accessories do we need for chipping?

"A" (Hand hammer, supports, vice.)

10. What is the basic principle for selecting the hammer?

"A" (The hammer must have double the weight of the chisel.)

11. Which property must supports have?

"A" (They must not be hardened so that they can absorb the impact of blows.)

12. Why must surface plates never be used as supports?

"A" (The penetrating chisel edge would leave notches and uneven spots on the plates so that they could no longer be used for their proper purpose.)

13. What do you have to take into account when chiselling a workpiece in a vice?

(You must hammer against the fixed jaw of the vice and use a firm counter-support.)

14. Which protective means are used to prevent accidents?

(Protective gratings or screens, goggles and impact protection.)

15. What is the task of protective screens and safety goggles?

"A" (To protect people from being hit by flying chips and fragments of workpieces.)

16. What is the action of chiselling?

(The impact of the hammer on the chisel head is transferred to the cutting edge, which can perform its chipping work now.)

17. What is the position of the chisel in a chipping operation?

"A" (The chisel inclination towards the surface of the workpiece is about 30°.)

18. How are metal sheets chiselled which are clamped in a vice?

(The chisel must be in an inclined position - with an angle of inclination of 45°.)

19. What is the position of the chisel in a cutting-off operation?

"A" (Perpendicular to the surface of the workpiece.)

20. How can we chisel off curved contours from thicker workpiece?

"A" (Scribing and punching of a bore line with a double-point punch; drilling; chiselling off the webs with mortise chisel.)

4. Application of the working technique of "Chipping"

Based on the variants mentioned in section 3, the exercises can be designed as a single subject-oriented instruction or in several stages.

Based on the "Instruction examples for practical vocational training - Chipping" the trainees can carry out 5 exercises with an increasing degree of difficulty.

These "Instruction examples ..." also comprise a list of materials (initial material, hand tools, measuring and testing tools, accessories) as well as a sequence of operations associated with the exercise. Also contained is an illustrative working drawing. Thus, the trainees avail of all the necessary information in order to begin their exercise-related work.

If the course of the exercise reveals that the quality of the workplaces does not meet the requirements, the trainees must carry out comprehensive preliminary exercises.

In this case they should use any waste parts. After having practised the skill sufficiently, the envisaged workpiece can be manufactured.

The following hint for organising the work should be taken into account :

The trainee has to carry out all the necessary work by himself - from cutting the initial material up to the completion of the workpiece.

This is the only way to guarantee a just evaluation of the achievements.

If the proposed instruction examples cannot be used for the exercises, it will be possible to select other workpieces. In this case the instructor has to make sure that the trainees can practise all the working techniques mentioned earlier.

4.1. Instruction examples

What follows is a brief description of the individual instruction examples in order to give a survey of those workpieces on which the knowledge previously acquired can

be practised.

Instruction example 10.1.

Training workpieces for cutting-off chiselling

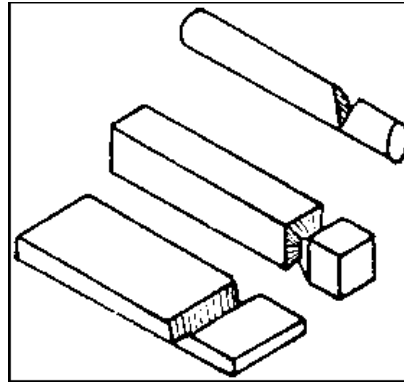

Figure

The technique of cutting-off chiselling will be practised at various cross-sections of steel.

Instruction example 10.2.

Case for safety goggles

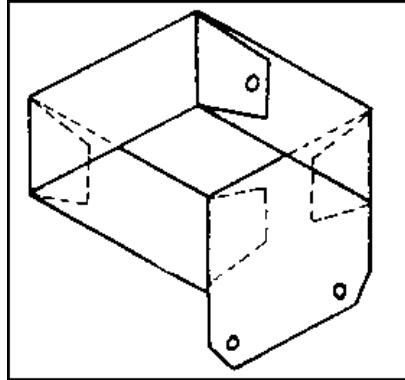

Figure

Cutting-off and shearing chiselling practises are employed to form a metal sheet in such a way that it can be bent to form a case. This case for safety goggles must be properly dimensioned. It can be fixed close to the drilling or grinding machines.

Instruction example 10.3.

Dog vice for sheet metal

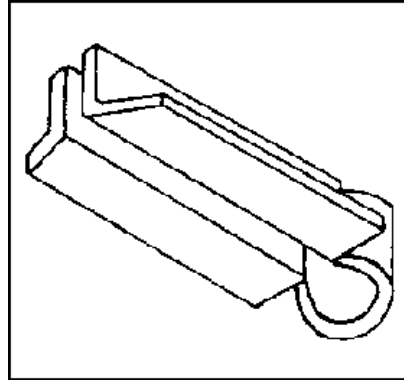

Figure

The trainee has to produce a bore line on angle steel and to chisel off sections and cut-outs. This workpiece can be used for clamping metal sheets in a workshop vice.

Instruction example 10.4.

Drilling support

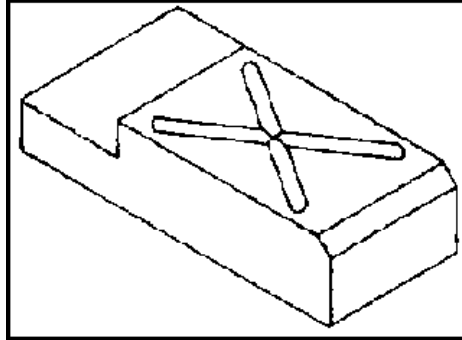

Figure

The trainees practise the chipping chiselling of surfaces and grooves on cast iron. They employ cape and grooving chisels.

After its completion this workpiece can be used as an accessory for drilling machines.

Instruction example 10.5.

Marking gauge

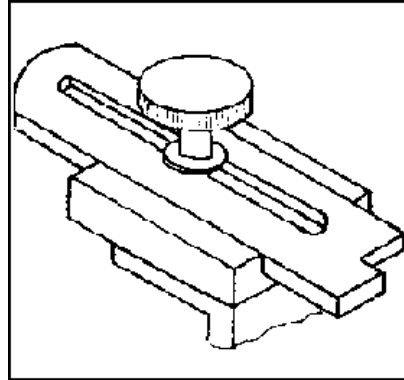

Figure

Several flat steel components serve to practise cutting-off and chipping chiselling by producing break-throughs and by working on surfaces. After its completion this device can be used as an accessory for marking-out operations.

4.2. Criteria for practical training

It is recommended to determine some crucial points of evaluation and supervision. The following criteria can serve as a guideline.

Cutting-off chiselling

- Is the chisel position precisely perpendicular?**
- Does the trainee drill the corner points in thin metal sheets and continue by chiselling on a hardened support?**

- **Does the trainee notch thicker sections from all sides in order to break them?**
- **Does the trainee prepare long dividing lines by producing a guide notch?**
- **Does the trainee prepare curved contours, which are to be chiselled off, by providing a bore line?**

Chipping Chiselling

- **Is the chisel position properly inclined?**
- **Does the trainee chisel off thin layers at narrow surfaces with the chisel in an angular position?**
- **Does the trainee chisel off thicker layers in several stages?**

5. Captions and legends of the "Chipping" transparencies series

Transparency no. 10.1. Position of chisel in chipping and cutting-off operations

- (1) chipping chiselling
- (2) cutting-off chiselling

Transparency no. 10.2. Principle of wedge penetration (chisel edge) into the material

- (1) equal wedge angles - unequal action of force

1 action of higher force

2 action of lower force (smaller depth of penetration)

(2) different wedge angles - equal action of force

3 smaller wedge angle

4 bigger wedge angle (smaller depth of penetration)

(3) different edge lengths - equal action of force and equal wedge angle

5 smaller length of edge

6 bigger length of edge (smaller depth of penetration)

Transparency
no. 10.3.

Kinds of chisels

(1) flat chisel (chipping chisel)

(2) round chisel

(3) cape chisel

(4) shear chisel

(5) grooving chisel

(6) mortise chisel

Transparency
no. 10.4.

Chiselling-off of thin metal sheets

(1) Scribing and drilling

1 scribed line

2 bore line

(2) Chiselling out of "webs" with a mortise chisel

Transparency Shearing-off of metal sheets

no. 10.5.

(1) shearing-off of longer metal sheets by shearing chisel and dog vice for sheet metal (angle steel with clamp)

1 dog vice for sheet metal

2 shearing chisel

(2) shearing process in a vice

3 vice jaws

4 chisel

angle of inclination of about 45°







[Home](#) > [ar.cn.de.en.es.fr.id.it.ph.po.ru.sw](#)



 **Manual Working of Material/Metal - Course: Manual working of metal. Methodical course-guide for instructors (Institut für Berufliche Entwicklung, 120 p.)**

  **Riveting**

-  **1. Objectives and contents of the practical vocational training in the working technique of "Riveting"**
-  **2. Organizational preparations**
-  **3. Recommendations for practical vocational training in the working technique of "Riveting"**
-  **4. Application of the working technique of "Riveting"**
-  **5. Captions and legends of the "Riveting" transparencies**

series**Manual Working of Material/Metal - Course: Manual working of metal. Methodical course-guide for instructors (Institut fr Berufliche Entwicklung, 120 p.)****Riveting****1. Objectives and contents of the practical vocational training in the working technique of "Riveting"**

By concluding their training the trainees shall have a good command of the working technique of "Riveting". Therefore, the following objectives have to be achieved:

Objectives

- **Knowledge of purpose and application of the riveting technique**
- **Proper command of the various working techniques of riveting and capability of joining workpieces in a workmanlike way.**
- **Capability of selecting the appropriate tools and accessories and of using them properly.**
- **Capability of evaluating the quality of their own work.**

The following contents have to be imparted to the trainees:

Contents

- **Purpose of riveting**
- **Kinds of rivets and riveted joints**
- **Tools and accessories for riveting**
- **Calculations for choosing rivets**
- **Technological process of riveting**
- **Detachment of riveted joints and riveting faults**

2. Organizational preparations

In order to guarantee a trouble-free development of the instructions, exercises and practical work it is necessary to prepare this training properly.

This includes the following steps:

2.1. Preparations for instructions in labour safety

Prior to the exercises the trainees have to be given a brief instruction in the proper use of tools and equipment. This comprises hints for accident-free work, too.

The main emphasis is similar to that of the working technique of "Drilling and Counterboring/Countersinking". The respective hints have to be repeated, and some supplementary points concerning the new working technique have to be added. These are the main points:

- Use flawless and well-fixed hammers only!
- Use suitable riveting supports only!

- Watch out for flying rivet heads during chiselling-off work - prepare protective screens or gratings!

Familiarity with these hints has to be confirmed by the trainees' signatures in a control book.

2.2. Provision of teaching aids

- **For demonstration purposes a vice and suitable riveting supports should be installed at the place of instruction.**
- **The "Trainees' Handbook of Lessons - Riveting" has to be handed out to the trainees in sufficient numbers.**
- **When using the transparencies series of "Riveting", check whether the series is complete (transparencies nos. 11.1. - 11.3.) and whether the overhead projector is in proper working order.**

(Check the operating conditions at the place of instruction and make sure of the proper mains supply!)

- **Surveys etc. which are to be written on the blackboard have to be completed prior to the instruction.**
- **All the tools and accessories mentioned in section 3 should be kept ready for illustrating the riveting technique.**

2.3. Provision of working tools and materials

- **Sufficient copies of the "Instruction examples for practical vocational training - "Riveting"" must be handed out to the trainees to provide them with the theoretical foundations for the exercises to be carried out.**
- **The initial materials necessary for these exercises have to be prepared and laid out in sufficient numbers - based on the materials mentioned in the "Instruction examples ...".**
- **Each trainee has to be provided with a workbench at which a vice is firmly installed (check the proper height of this vice!).**
- **The trainees' workbenches have to be fully equipped with tools and accessories - based on the planned exercises.**

Recommended basic equipment:

- **steel rule, try square, vernier caliper**
 - **steel scriber, marking gauge, punch**
 - **locksmith's hammer, aluminium hammer**
 - **hand hacksaw**
 - **bastard and smooth files 250 mm (flat)**
 - **C-clamps**
 - **rivet set and header for rivet diameters of 3 to 5 mm.**
- **Bench- or column-type drilling machines and the necessary clamping tools (machine vices, holding clamps, C-clamps) must be provided for the required preliminary work (drilling and counterboring/countersinking).**

- **Prior to the start of the exercises the working order of the drilling machines has to be checked in compliance with the regulations on labour safety.**

2.4. Time schedule

Time planning is recommended for the following training stages:

- **introduction to the working techniques in the form of instructions**
- **necessary demonstrations**
- **job-related instructions to prepare the exercises**
- **carrying out the exercises**
- **recapitulations and tests.**

The necessary time share depends on the respective training conditions. Most of the time is to be allocated to the exercises.

3. Recommendations for practical vocational training in the working technique of "Riveting"

The following paragraphs comprise proposals on conducting trainee instructions, demonstration of working techniques as well as on exercises and tests. Two course variants are recommended:

Variant no. 1

This variant should be chosen for trainees with previous knowledge and generally good achievements and receptiveness.

- 1.1. Introductory instruction with demonstrations based on the "Trainees' Handbook of Lessons".**
- 1.2. Exercises in riveting based on the "Instruction examples 11.1. - 11.5.".**
- 1.3. Final test of theory knowledge based on the "Examples for recapitulation and tests".**

Variant no. 2

This variant should be chosen for trainees with little previous knowledge or poor achievements.

- 2.1. Introductory instruction with demonstrations based on the "Trainees' Handbook of Lessons".**
- 2.2. Exercises in the technique of countersunk-head riveting based on the "Instruction examples 11.1. and 11.2." with subsequent evaluation.**
- 2.3. Additional instruction in the subject of "button-head riveting" based on the "Trainees' Handbook of Lessons".**
- 2.4. Exercises in riveting of button-head rivets based on the "Instruction examples 11.3. - 11.5." with subsequent evaluation.**
- 2.5. Final test of theory knowledge based on the "Examples for recapitulation and tests".**

Practical skills should be checked after handing over the completed workpiece immediately. Theory knowledge can be checked constantly. However, it is recommended to have a final test written (item 1.3. to 2.5.) after the exercises.

3.1. Introductory instruction

If possible, this instruction should be conducted in a classroom.

Make sure that the trainees put down necessary and supplementary notes or answers to questions in their "Trainees' Handbook of Lessons". Based on the main points contained in the "Trainees' Handbook of Lessons", the instructor can deal with the subject of instruction.

The instruction in the field of tools and accessories must be greatly supported by all the teaching aids available.

Purpose of riveting

The instruction begins with comments on kinds of joints of workpieces. This instruction is to show riveting as a technique which is still in use in various industrial and craftsmen's establishments, but which is mainly replaced by other material- and time-saving techniques, e.g. welding and glueing. The instruction can be supported by transparency no. 11.1.

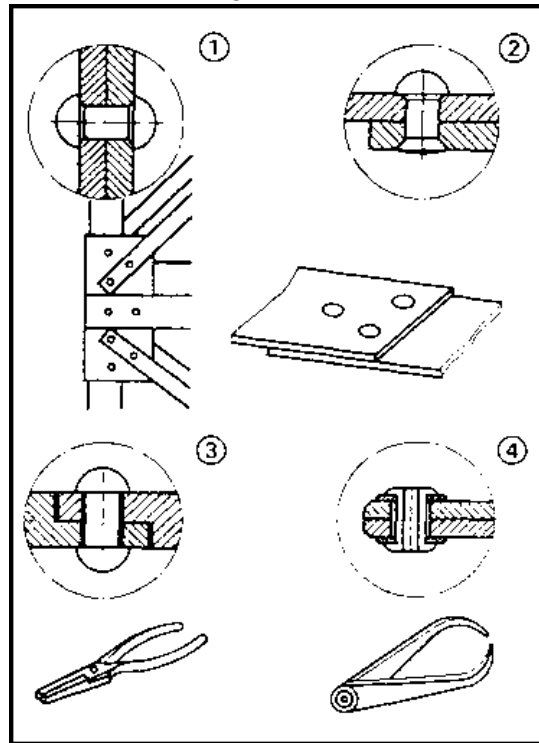

Figure 11.1

Kinds of rivets and riveted joints

The description of these kinds should follow the list contained in the "Trainees' Handbook of Lessons".

- **button-head rivet**
- **countersunk-head rivet**
- **oval-head countersunk rivet**
- **boiler rivet**
- **explosive rivet**
- **strap rivet**
- **hollow or pipe rivet**
- **pin-type rivet (spigot).**

This list should be supplemented by additional comments on the fields of use of the rivets. The comments can be based on the detailed hints contained in the "Trainees' Handbook of Lessons" When speaking about the different kinds of riveted joints, the instructor is recommended to deal with the following points:

- kind of joint: butt joint or lap joint
- number of rows: single row or multiple row
- rivet arrangement: parallel or zigzag

Tools and accessories for riveting

The following tools for cold riveting have to be introduced and explained to the trainees:

- **riveting hammer**
- **rivet set**
- **rivet header**
- **riveting supports (fixed and adjustable)**

- clamping tools.

The following items have to be added when speaking about the hot-riveting process:

- forge fire**
- riveting block**
- riveting tongs.**

Calculations for choosing rivets

This subject is to be explained by commenting on the following terms:

- rivet shank diameter (1)
- rivet shank length (2)
- allowance (3)
- thickness of plates being joined (4)

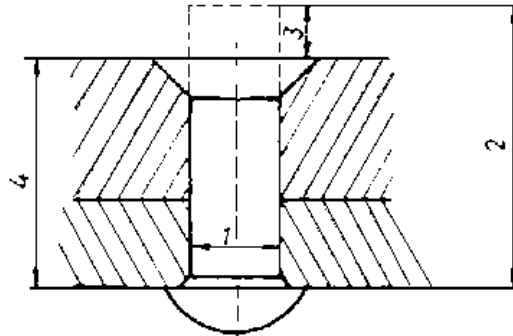

Figure

This instruction should be supported by this figure as large-size representation on the blackboard.

The trainees have to learn that it is not always possible to get data on the rivets to be used. Very often there are no drawings available when repairwork has to be done. Thus, the trainees have to learn how to calculate the dimensions etc. of rivets to be used.

These calculations are to be based on the hints contained in the "Trainees' Handbook of Lessons".

The following formulae shall be used:

$$D = \frac{1}{4} \times s$$

$$L = s + A$$

D = diameter of rivet shank

s = thickness of plates being joined

L = length of rivet shank

A = allowance.

The trainees have to understand the differences between countersunk-head riveting and button-head riveting operations in order to see why the differences in allowances occur in the following survey:

Allowances for button-type closing heads

- in steel construction: up to rivet shank diameters of 20 mm

$$\underline{A = 1.5 \times D}$$

rivet shank diameters exceeding 20 mm

$$\underline{A = 1.6 \times D}$$

- in boiler construction:

up to rivet shank diameters of 20 mm

$$\underline{A = 1.7 \times D}$$

rivet shank diameters exceeding 20 mm

$$\underline{A = 1.8 \times D}$$

Allowances for countersunk closing heads:

$$\underline{A = 0.5 \times D}$$

The instructor has to teach the trainees that the calculated value has to be rounded off to the next standard rivet shank diameter.

The standard sizes are to be taken from the relevant tables. The trainees have to practise the use of these formulae by calculating several arithmetical examples (as contained in the "Trainees' Handbook of Lessons").

Technological process of riveting

The individual operations should be discussed in detail in the following order:

- clamping/drilling - upsetting
- deburring/countersinking - preforming/heading
- insertion/drawing-in - finish-forming of button head (closing head).

These steps are described in detail and illustrated in the "Trainees' Handbook of Lessons". The following recommended values for drilling and countersinking should be written on the blackboard:

| diameter of rivet | diameter of drilled hole | diameter of countersunk hole |
|--------------------------|---------------------------------|-------------------------------------|
| (D) | (D _B) | (D _S) |
| 1 | 1.1 | 1.8 |
| 2 | 2.2 | 3.5 |
| 3 | 3.2 | 5.2 |
| 4 | 4.3 | 7 |
| 5 | 5.3 | 8.8 |
| 6 | 6.4 | 10.3 |
| 8 | 8.4 | 14 |

After having explained this theoretical content of the subject, the instructor demonstrates these practises. He performs a simple and rigid countersunk riveted joint of two steel sheets of about 4 mm thickness by a countersunk-head rivet of a diameter of 4 mm. Subsequently, the trainees are shown the button-head riveting technique (same size).

The trainees have to watch the individual steps carefully. One of the trainees has to repeat this practice immediately afterwards. Mistakes he makes have to be revealed and corrected at once. The instructor must not forget to give the following hint:

Manual riveting of cold rivets is applied for steel rivets up to 8 mm diameter.

Thicker rivets must be riveted in a red-hot state.

The instructor has to mention the peculiarities of riveting with rivet bolts, too. He has to demonstrate how to preform a die head. Transparency no. 11.2. can serve to illustrate this process.

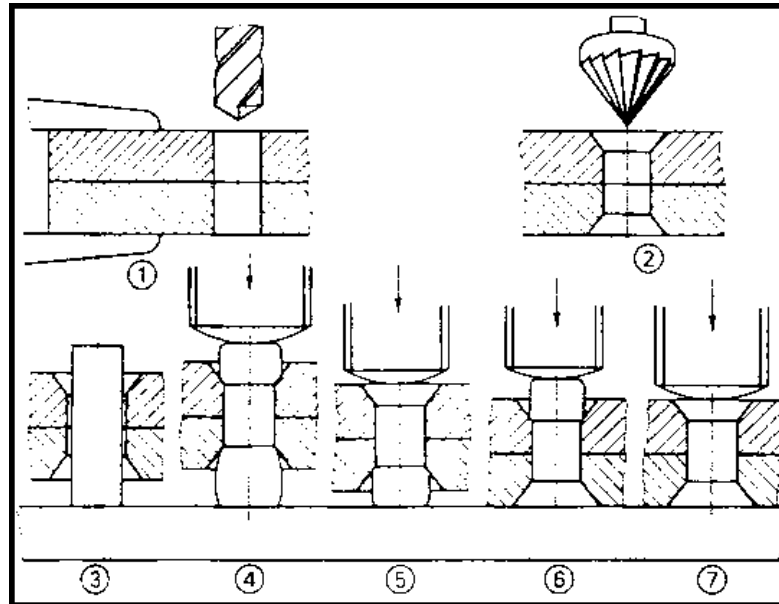

Figure 11.2

Detachment of riveted joints and riveting faults.

Chiselling off, drilling and grinding off are to be mentioned as methods of destroying rivets. This work has to be carried out in compliance with the labour safety regulations.

Subsequently, the instructor mentions the features of frequently occurring riveting faults. The figures and descriptions contained in the "Trainees' Handbook of

Lessons" or transparency no. 11.3. should be used as teaching aids.

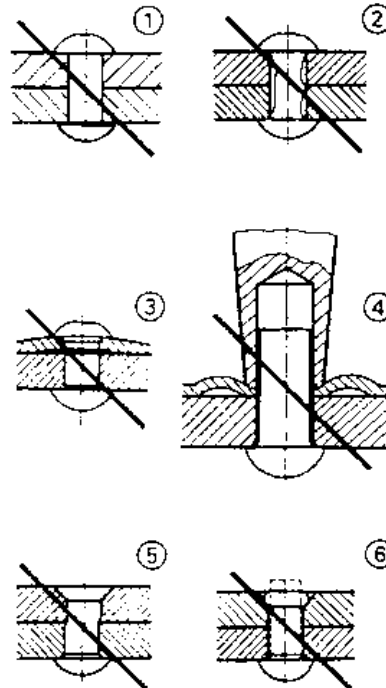

Figure 11.3

3.2. Exercises

If it has not been possible to include the individual demonstrations in the instructions, this should be done right now before the start of the exercises. If the

trainees avail of only little practical skill, they should do some preliminary exercises on any small-size work-pieces:

- **small countersunk-head riveted joints on flat material**
- **smaller-scale button-head riveted joints on flat material**

However, it is also possible to begin with the first exercises contained in the "Instruction examples for practical vocational training".

But it is necessary to prepare every individual exercise by a brief "job-related instruction", during which the trainees will be shown a finished workpiece in order to illustrate the objectives and crucial points of this exercise.

The instructor must have completed such a workpiece himself in order to be familiar with all the problems which might arise in producing such a workpiece.

Thus, the instructor is capable of clearly defining the main points of evaluation and of assessing the achievements. During these instructions the sequences of operations and the working drawings of the "Instruction examples" should be placed on the desks so that the trainees can make additional notes therein. The trainees can carry out all the exercises simultaneously in the mentioned order, if sufficient tools etc. are available.

If this is not the case, the trainees have to be grouped - based on the main subjects of the tasks and number of tools available:

group no. 1 - production of countersunk-head riveted joints

group no. 2 - production of button-head riveted joints.

The following hints for operating the drilling machines must be borne in mind:

The trainees must not operate the drilling machines before they are familiar with the function of the control elements!

The instructor has to check whether the trainees had been given the instruction in operating drilling machines (based on the entries in the control book of labour safety instructions). If this is not the case, this must be done now.

During the exercises the instructor must permanently supervise the trainees: No practice without supervision! Special attention must be drawn to the production of holes. It is recommended to always check the clamping tools for firm clamping.

It is also advisable for the instructor to demonstrate again the operation of the machine, the clamping of the workpiece and the drilling operation. Special emphasis is to be laid on the process of centring (alignment of hole and work spindle), if the work-piece had been unclamped between the stages of drilling and countersinking.

As it will not be possible to provide each trainee with a drilling machine, the instructor has to determine the proper succession in which the trainees will operate the machines already during the job-related instruction (instruction examples).

During the exercise the instructor has to make sure that only one trainee operates the machine. Several trainees at one machine could distract each other from working and increase the danger of accidents!

Trainees who cannot begin with riveting work should do some other work in the workshop in the meantime: selection and preparation of initial materials, control of and minor repair work on working tools etc. under the supervision of the instructor. However, it is also possible to carry out additional and consolidating exercises of working techniques acquired earlier.

3.3. Examples for recapitulation and tests

This section comprises questions which are to consolidate and test the acquired knowledge and skills. Each question is provided with the respective answer. Questions which are also contained in the "Trainees' Handbook of Lessons" are marked with the letter "A".

1. What is the purpose of riveting?

(Production of a permanent connection of two or more work-pieces.)

2. What properties can riveted joints have?

"A" (They can be rigid, movable, tight, rigid and tight.)

3. Why is riveting a connection which cannot be detached again?

"A" (Because the rivet as a connecting element must be destroyed, if the connection is to be detached.)

4. What are the materials rivets are made of?

"A" (They are made of tough steel; copper, brass, aluminium.)

5. What is the main property which these materials must have?

"A" (They must be tough, flexible - well formable.)

6. Which kinds of rivets do you know?

(Button-head rivets, countersunk-head rivets, oval-head countersunk rivets, boiler rivets, strap rivets, hollow rivets.)

7. When do we employ button-head rivets?

"A" (Button-head rivets are used to make particularly tight or rigid connections, which are not affected by the projecting rivet head.)

8. When do we employ countersunk-head rivets?

"A" (Countersunk-head rivets are used when the surface must not have irregularities and the planned joints are not too highly stressed.)

9. What are the criteria for differentiating firm rivet connections?

(Kind of joint, number of rows, arrangement of rivets.)

10. Which tools and accessories are necessary for cold riveting by hand?

"A" (Riveting hammer, rivet set, rivet header, riveting support, surface plate, clamping tools.)

11. What is the function of a rivet set?

"A" (Pressing of the metal sheets to be riveted and setting the die head to the metal sheets.)

12. Which rivet can be used for joining three metal sheets of 5 mm thickness each with a countersunk-head rivet?

"A" (Countersunk-head rivet 4 x 17.)

13. Which values do we have to calculate, if the kind of riveting is not given in detail

on the drawing?

(Diameter of rivet shank, length of rivet shank, diameter of drilled hole, diameter of countersunk hole.)

14. What are the individual steps to be taken when producing a button-head countersunk riveted joint?

"A" (Clamping, drilling, deburring, insertion, drawing-in, upsetting, pre-forming, finish-forming.)

15. What can we do if separately drilled components do not have aligned holes after being put together?

"A" (We must ream them up by means of a taper reamer.)

16. What hole must we drill for a 4 mm thick rivet?

"A" (4.3 mm.)

17. What kind of a countersink do we need in order to prepare countersunk-head riveted joints?

"A" (75° countersink.)

18. What is the diameter of the countersunk hole for a countersunk-head rivet of 4 mm?

"A" (7 mm.)

**19. What is the upper limit of steel rivet diameters for cold riveting?
(About 8 mm.)**

20. Why should non-ferrous metal rivets by annealed before the riveting process

begins?

"A" (Annealing will increase their elasticity or, resp., plasticity.)

21. Why must we apply only a few but straight blows when we rivet the closing head?

"A" (In order not to cold-harden the rivet and in order to preserve its toughness.)

22. How can we detach riveted joints?

"A" (Destruction of rivet head by chiselling, drilling, grinding.)

23. What riveting faults can have occurred, if we recognize that the closing head is not fully formed?

"A" (Shank of rivet too short, metal sheets are not fully pulled together, drilled hole too big for rivet, rivet header too big, rivet hole is not countersunk.)

4. Application of the working technique of "Riveting"

Based on the variants described in section 3, the exercises can be designed as a single instruction or in several stages of exercises. Based on the "Instruction examples for practical vocational training" the trainees can manufacture 5 workpieces of different degrees of difficulty. These "Training examples ..." also comprise a list of materials (initial materials, hand tools, measuring and testing tools, accessories) as well as the sequence of operations associated with manufacturing of the workpiece. Also contained is an illustrative working drawing. Thus, the trainees will avail of all the necessary information to begin their exercise-related work.

If the instructor finds out in the course of the exercises that the quality of the

workpieces produced is not sufficient, the trainees must carry out more comprehensive preliminary work. In this case it is recommended that waste components be used. After having practised this skill, the planned workpiece can be produced. The following hint should be taken into account:

The trainee has to do all the necessary work by himself - from cutting the initial material up to the completion of the workpiece. This is the only way to guarantee a just evaluation of the trainee's achievements.

If the proposed "Instruction examples ..." are not included in the exercises, it will be also possible to select other workpieces. In this case the instructor has to make sure of it that all the working techniques mentioned before will be practised with this workpiece.

4.1. Instruction examples

What follows is a brief description of the individual instruction examples in order to give a survey of those workpieces on which the previous knowledge can be practised:

Instruction example 11.1.

Protective jaws

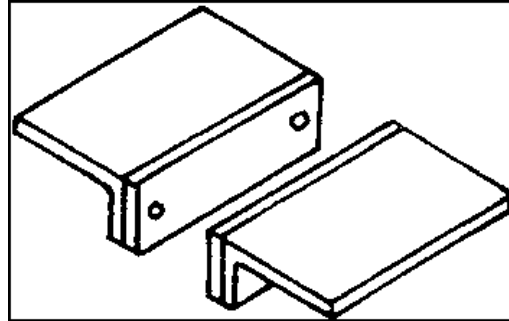

Figure

An aluminium sheet and a steel sheet will be rigidly joined by double-sided countersunk-head riveting. The trainees use rivet bolts of 4 mm aluminium wire.

After their completion these protective jaws can be used as accessories for clamping of components with sensitive surfaces in a vice.

Instruction example 11.2.

Try square

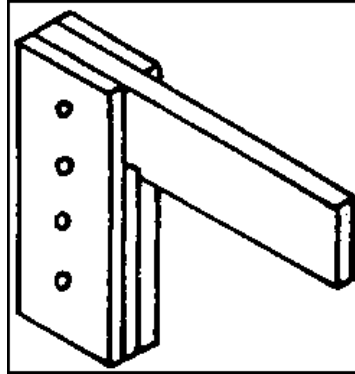

Figure

Three steel sheets are firmly joined by countersunk-head rivets in one row. The trainees will use pre-fabricated countersunk rivets of steel (4 mm). After its completion the try square can be used as a testing tool for squareness.

Instruction example 11.3.

Waste shovel

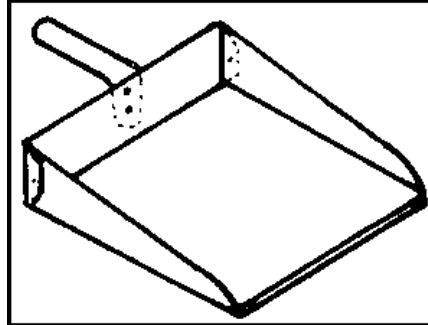

Figure

Steel sheets will be rigidly joined by double-sided button-head rivets. The trainees use 4 mm rivet bolts of copper wire. This shovel for waste disposal can be used for cleaning purposes in the workshop.

Instruction example 11.4.

Waste bin

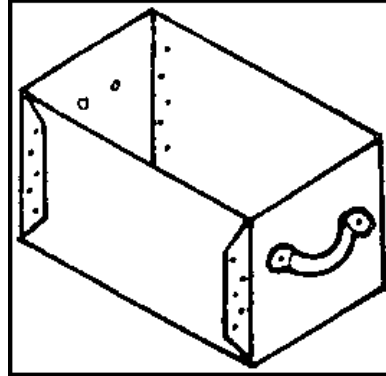

Figure

The trainees will practise two-row zigzag riveting with button-head rivets of copper and steel in order to rigidly join steel sheets. Its dimensions are chosen to adapt it to the envisaged purpose of use in the workshop.

Instruction example 11.5.

Key-bolt for cabinets

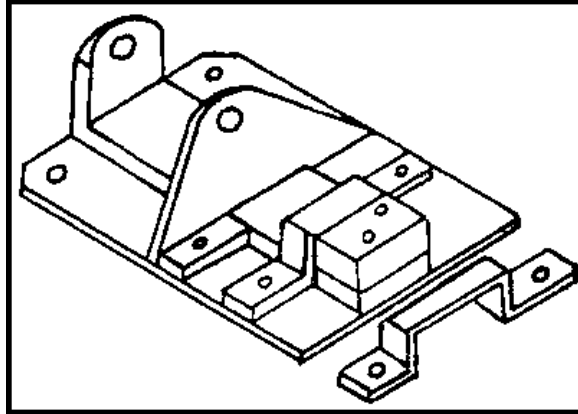

Figure

Several components will be joined by combined button-head and counter-sunk rivets. The trainees use button-head rivets of 4 mm and countersunk rivets of steel. This key-bolt for cabinets can be combined with a padlock and form a firm locking mechanism for tool cabinets.

4.2. Criterial for practical training

It is recommended to determine certain points of evaluation and supervision. The following criteria can serve as a guideline:

Preparation

- Did the trainee calculate the rivet dimensions exactly?**
- Did the trainee select the appropriate rivet?**

Clamping/drilling

- **Did the trainee select the appropriate drill?**
- **Have the workplaces been firmly clamped and drilled jointly?**
- **Does the trainee properly ream up non-aligned holes?**

Deburring/countersinking

- **Does the trainee use the appropriate countersink?**
- **Does the diameter of the countersunk hole comply with the exact tabular value?**

Insertion/drawing in

- **Does the trainee insert the rivet with the die head at the bottom?**
- **Does the trainee use the rivet set for tightening the metal sheets?**

Upsetting

- **Does the trainee hammer exactly into the direction of the longitudinal axis of the rivet?**

Pre-forming/heading

- **Does the trainee appropriately pre-form the button head by uniform blows around the rivet head?**
- **Does the trainee hammer the countersunk head cleanly into the countersunk hole?**

Finish-forming

- **Does the trainee use the appropriate rivet header?**
- **Does he form the button head cleanly?**

5. Captions and legends of the "Riveting" transparencies series

Transparency Application of rivet joints
no. 11.1.

- (1) Rigid rivet joint in steel construction
- (2) Rigid rivet joint of metal sheets (sheet metal rivet with button head and countersunk head)
- (3) Movable rivet joint (universal joint with button-head rivet)
- (4) Movable rivet joint (universal joint with hollow rivet)

Transparency Working operations for double-sided countersunk riveted joint with rivet
no. 11.2. bolts

- (1) Drilling of the clamped metal sheets
- (2) Countersinking on both sides with 75 countersink
- (3) Insertion of rivet bolt and setting up on riveting support
- (4) Upsetting of shank
- (5) Forming of upper countersunk head
- (6) Turning over of metal sheets - upsetting of closing head
- (7) Forming of closing head

Transparency Riveting faults
no. 11.3.

- (1) Rivet hole was not deburred; compression at the hole edge; closing head not fully formed.
- (2) Rivet hole too big; bending of shank ; closing head not fully formed.
- (3) Upper metal sheet not fully tightened; shank compressed between metal sheets; closing head not fully formed.
- (4) Rivet joint too tight ; upper metal sheet compressed.
- (5) Rivet holes offset; notched rivet shank.
- (6) Rivet shank too short; closing head not fully formed.







[Home](#) > [ar.cn.de.en.es.fr.id.it.ph.po.ru.sw](#)



 **Manual Working of Material/Metal - Course: Manual working of metal. Methodical course-guide for instructors (Institut fr Berufliche Entwicklung, 120 p.)**

  **Grinding of Simple Tools**

-  **1. Objectives and contents of practical vocational training in the working technique of "Grinding of Simple Tools"**
-  **2. Organizational preparations**
-  **3. Recommendations for practical vocational training in the working technique of "Grinding of Simple Tools"**
-  **4. Application of the working technique of "Grinding of Simple Tools"**



5. Caption and legends of the "Grinding of Simple Tools" transparencies series

Manual Working of Material/Metal - Course: Manual working of metal. Methodical course-guide for instructors (Institut fr Berufliche Entwicklung, 120 p.)

Grinding of Simple Tools

1. Objectives and contents of practical vocational training in the working technique of "Grinding of Simple Tools"

By concluding their training, the trainees shall have a good command of the working technique of "Grinding of Simple Tools". Therefore, the following objectives have to be achieved:

Objectives

- Knowledge of purpose and application of the off-hand sharpening technique.**
- Proper command of the working techniques and capability of off-hand sharpening of the most common tools.**
- Capability of making decisions on the quality of their work independently.**

The following contents have to be imparted to the trainees:

Contents:

- **Purpose of sharpening**
- **Machines and tools for sharpening**
- **Action of grinding and whetting**
- **Applications of off-hand sharpening**
- **Hints for mounting and dressing of grinding wheels**

2. Organizational preparations

In order to guarantee a trouble-free development of the instructions, exercises and practical work it is necessary to prepare this training properly.

This includes the following measures:

2.1. Preparations for instructions on labour safety

Prior to the exercises a brief instruction on the proper use of tools and equipment has to be given. This comprises hints for accident-free work too.

The following main subjects have to be imparted to the trainees:

- **Only one trainee must work at a grinding machine at a time.**
- **A safety distance of at least 1 m around the grinding machine is to be observed.**
- **A trainee at the grinding machine must never be distracted, pushed or teased.**

- **The conditions of safety at the grinding machine have to be permanently checked:**
 - **maximum distance of grinding support 1 - 2 mm.**
 - **distance of spark killer 5 mm (maximum)**
- **Grinding machines without attached eyeshields must be operated with the safety goggles on.**
- **Never grind the tools without the guidance of the left hand.**
- **Grinding wheels must be stressed frontally only - no lateral stress is allowed.**
- **You must never wear gloves or use pieces of cloth when holding the tools during sharpening.**

Familiarity with these hints has to be confirmed by the trainees signatures in a control book.

2.2. Provision of teaching aids

The "Trainees' Handbook of Lessons - Grinding of Simple Tools" has to be handed out to the trainees in sufficient numbers. When using the transparencies series of "Grinding of Simple Tools" check whether they are complete (transparencies nos. 12.1. - 12.3.) and whether the overhead projector is functional. (Check whether the operating conditions are appropriate on the spot and make sure of the proper mains supply.) Surveys etc. which are to be written on the blackboard have to be

completed prior to the instruction.

All the grinding wheels and tools to be sharpened mentioned in section 3 should be kept ready for illustration purposes.

2.3. Provision of working tools and materials

Sufficient copies of the "Instruction examples for practical vocational training - Grinding of Simple tools" must be handed out to the trainees to provide them with the theoretical foundations for the exercises to be carried out.

Based on the materials listed in the "Instruction examples ..." the initial materials necessary for the exercises have to be prepared and laid out in sufficient numbers.

For simple repair work or the production of tools the workbenches of the trainees have to be provided with firmly installed vices. The instructor has to check whether the workbenches are fully equipped with tools and accessories - based on the planned exercises - if other repair work or the production of new tools is planned in addition to sharpening.

Recommended basic equipment:

- vernier caliper, protractor, grinding gauge**
- steel scriber**
- hand hacksaw, locksmith's hammer**
- whetstone.**

Based on the number of trainees a sufficient number of grinding machines (bench-

type and pedestal grinding machines) is to be provided.

For the purpose of off-hand sharpening of tools made of tool steel, flat wheels made of corundum must be available.

Tools with carbide cutting edges require flat wheels made of silicon carbide.

2.4. Time schedule

Time planning is recommended for the following training stages

- introduction to the working technique in the form of instructions**
- necessary demonstrations**
- job-related instructions for carrying out the exercises**
- carrying out the exercises**
- recapitulations and tests.**

The necessary time share depends on the respective training conditions. The biggest time share is to be allocated to the exercises.

3. Recommendations for practical vocational training in the working technique of "Grinding of Simple Tools"

The following paragraphs comprise proposals on conducting trainee instruction, demonstration of the working techniques and on the form of exercises and tests.

The following course of events is recommended:

- **Introductory instruction accompanied by demonstrations based on the "Trainees' Handbook of Lessons".**
- **Exercises in sharpening based on the "Instruction examples 12.1. - 12.5." and subsequent evaluation.**
- **Final test of theory knowledge based on the "Examples for recapitulation and tests".**

Practical skills should be checked immediately after handing over the completed workpiece. Theory knowledge can be checked constantly. However, it is recommended to have a final test written after the exercises.

3.1. Introductory instruction

If possible, this instruction should be conducted in a classroom. Make sure that the trainees put down necessary supplements and answers to questions in the "Trainees' Handbook of Lessons".

The subjects of instruction can follow the main points contained in the "Trainees' Handbook of Lessons".

Purpose of sharpening

The instructor shows dull tools (chisels, drills) and workpieces which were treated with these tools in order to explain the purpose of sharpening the tools to the trainees. The instructor has to point out that the use of dull or damaged tools can result in great losses. The trainees have to understand that the technique of off-

hand sharpening is high-quality manual work. They will learn that nearly all the common tools in a locksmith's shop are maintained this way.

Machines and tools for sharpening

Based on the hints contained in the operating manuals and folders the instructor makes the trainees familiar with the bench-type and pedestal grinding machines in the workshop. The basic design of a bench-type grinding machine can be also seen on transparency no. 12.1.

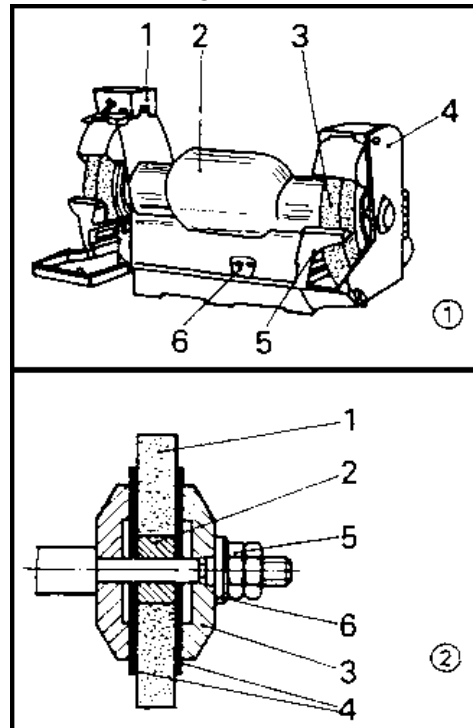

Figure 12.1

The grinding wheels used as tools for sharpening are the subject of the subsequent instruction in the different forms and structural composition of such wheels. The following forms should be illustrated:

- flat grinding wheels

- **dish wheels**
- **cup wheels.**

If these grinding wheels are not available as originals, transparency no. 12.3. or the figures contained in the "Trainees' Handbook of Lessons" can be employed as teaching aids. It is also recommended to demonstrate coarse, medium and fine-grained grinding wheels and their respective fields of application. The trainees should be shown the silicon carbide and corundum wheels used for off-hand sharpening. They must learn to select the proper wheels by eyesight.

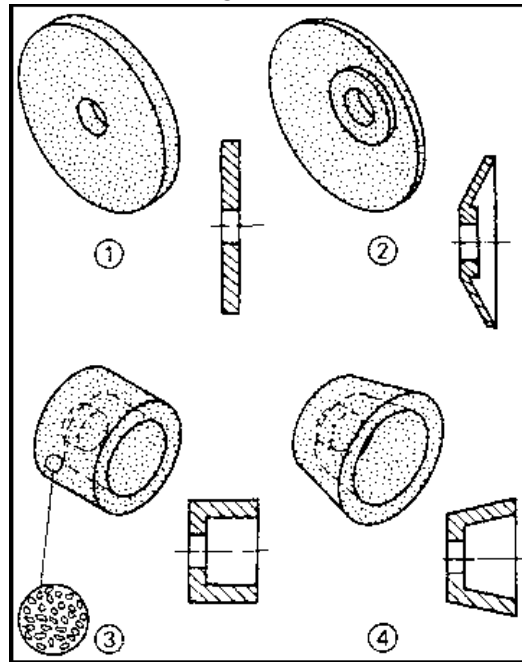

Figure 12.3

Action of grinding and whetting

The action of grinding can be seen during the grinding process.

Transparency no. 12.2. can support the necessary explanations. As some burrs will occur at the cutting edge during the grinding process, the trainees are given a detailed description of the whetting process. It is recommended to demonstrate the

position of the cutting edge on the whetstone and the kinds of movement involved in whetting. The instructor should never forget to underline the importance of this process and to stress that tool life greatly depends on an exact whetting process. (The tool life of a properly whetted chisel can be four times as long as that of a chisel which has not been whetted).

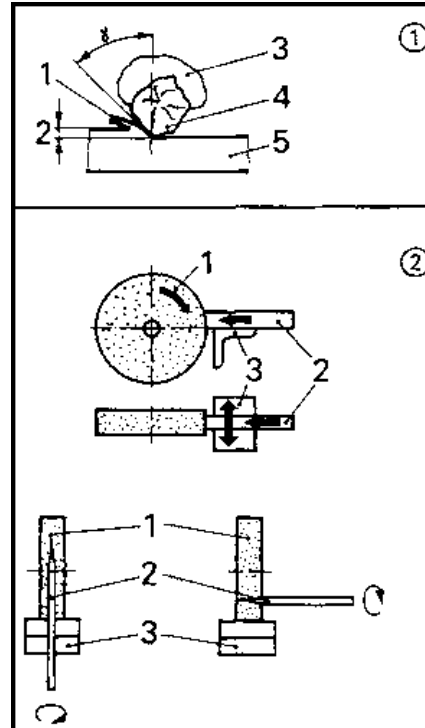

Figure 12.2

Applications of off-hand sharpening

Based on the detailed descriptions contained in the "Trainees' Handbook of Lessons", the instructor can describe the sharpening technique for the following tools:

- centre punch and scriber
- flat chisel
- drill with standard drill point

This description can be supported by using the sequences of operations given in the "Instruction examples for practical vocational training". As the different positions of the hand are the main point in these processes, the trainees must be demonstrated how to hold the tools. The instructor can do so by simply showing a grinding wheel and the hand positions associated with grinding. This must be supplemented by repeated demonstrations at a grinding machine later.

Hints for mounting and dressing of grinding wheels

The instruction in mounting the grinding wheels should follow the order contained in the "Trainees' Handbook of Lessons". When describing the individual activities the instructor has to mention all the associated safety regulations. These activities must be carried out in a workshop under the supervision of the instructor only. Supervision is also necessary for dressing of grinding wheels with a hand dresser.

3.2. Exercises

If it has not been possible to include the demonstrations in the instructions by now, this should be done right now prior to the beginning of the exercises.

These demonstrations must be so designed that not more than two trainees watch them at a time. These trainees have to repeat this action immediately afterwards under the supervision of the instructor. It will be necessary for the instructor to repeat these demonstrations frequently, for the proper sharpening technique can be only acquired by detailed observation and immediate duplication.

Subsequently, the trainees can begin with their first exercises based on the "Instruction examples for practical vocational training".

However, it will be necessary to prepare every individual exercise by a "job-related instruction". This comprises the demonstration of a finished workpiece in order to underline the purpose and objectives of this exercise.

The instructor must have completed such a workpiece himself in order to understand all the problems involved in the production of the workpiece.

Thus, the instructor can clearly indicate the main points of evaluation and assessment of the achievements as well as crucial manufacturing areas. During these instructions the sequences of operations and the working drawings of the "Instruction examples" should be placed on the desks so that the trainees can make notes therein.

The trainees can carry out all the exercises simultaneously in the given order, provided that the number of tools etc. will allow this. If this is not the case, the

trainees have to be grouped into teams - based on the tasks and the number of tools, machines etc. available.

If there are only a few grinding machines available, the exercises in sharpening should be done in parallel with exercises in other working techniques. Preferably, the techniques of "drilling, countersinking and counterboring" as well as "manual reaming" and "manual thread cutting" should be practised. During these exercises waiting times might occur at the drilling machines, and these times could be usefully bridged by exercises in sharpening.

The supervision of the instructor has to concentrate on some crucial points:

Since it is difficult to learn the proper positioning of the hands, as can be seen from repeatedly occurring handling errors, the instructor has to keep a close eye on the trainees. The instructor can reduce the trainees' anxieties caused by the rotating grinding wheels through calm and steady demonstrations and permanent supervision.

The trainees are requested to have their tools checked frequently. The instructor can recognise errors in the position of hands from the characteristic grinding pattern. If a trainee does not learn the proper handling techniques - even after prolonged exercises - the instructor has to guide the trainee's hands for a while. The exercise is characterised by & constant alternation of demonstration and duplication.

Exercises at the grinding machine should not exceed 2 hours, because the attention of the trainees will slacken off very fast. In addition, you have to keep in mind that

bench-type and pedestal grinding machines are not designed for continuous operation - danger of overheating. This is the reason why the sharpening process should be interrupted by other working techniques. Thus, the "Instruction examples..." concentrate on the production of simple tools and the subsequent sharpening operation.

3.3. Examples for recapitulation and tests

This section comprise questions which are to consolidate and test the previously acquired knowledge and skills. Each question is provided with the respective answer. Questions which are also contained in the "Trainees' Handbook of Lessons" are marked with the letter "A".

1. What is the purpose of sharpening?

(Cutting edges of tools have to be prepared for cutting in manufacturing processes by grinding and whetting or dull edges are re-ground for further use.)

2. What is the advantage of off-hand sharpening?

"A" (You can do it at any grinding machine immediately without any time-consuming preparations.)

3. Which tools can be treated by off-hand sharpening?

(Steel scribes, scribes of beam trammels and scribing blocks; centre punches, chisels and drills of all kinds, screwdrivers and scrapers.)

4. Which is the main wheel form used in off-hand sharpening?

"A" (Flat wheel.)

5. When do we use cup wheels for sharpening?

"A" (In case we have to create flat surfaces without any hollow grinding.)

6. What are the components of a grinding wheel?

(Abrasive and bonding agent.)

7. What kinds of wheels are used for off-hand sharpening?

(Corundum wheel and silicon carbide wheel.)

8. What kind of wheel is used for sharpening tools made of tool steel?

"A" (Soft to medium-hard corundum wheel with medium grain size.)

9. What is the action of grinding?

"A" (Irregularly shaped abrasive grains will shave fine segmental chips from the workpiece.)

10. What do we understand by 'self-sharpening' of the grinding wheel?

"A" (Dull abrasive grains will get loose by the pressure of the workpiece and they will give way to the sharp abrasive grains which lie behind them.)

11. What is the purpose of whetting?

"A" (The occurring sharpening burr has to be removed from the tool cutting edge in order to increase the tool life.)

12. How do we whet a cutting edge?

(Both sides of the edge are to be angularly rubbed on the whetstone until the burrs are removed.)

13. What is typical of the technique of sharpening punches and scribes?

"A" (Sharpening of the tapered end in a horizontal position, sharpening of the points in a vertical position.)

14. What is typical of the technique of sharpening chisels?

"A" (Vertical sharpening of the cutting edge in a slightly upward position and with simultaneous to-and-for-movements.)

15. What is the working movement for sharpening drills?

"A" (The main cutting edge of the drill is brought into a horizontal position and then the drill is pressed upwards and to the right simultaneously.)

16. Which angles are to be maintained when grinding drills with standard drill point?

- angle of point 118°
- complementary angle of the drill edge angle 55°
- clearance angle $4-6^\circ$

17. What grinding faults can we detect by eyesight?

- unequally long main cutting edges
- main cutting edges with unequal angles
- hollow-ground main cutting edges

18. What do we understand by 'drill-pointing'?

"A" (This is the lateral resharpening of the drill edge in a vertical position.)

**19. Why is it necessary to dress grinding wheels?
(To guarantee true running and surface finish of the grinding wheel.)**

4. Application of the working technique of "Grinding of Simple Tools"

The exercises can follow the order given in the "Instruction examples for practical vocational training - Grinding of Simple Tools" for 5 (or, resp. 8) examples.

These "Instruction examples..." contain a list of materials (initial materials, hand tools, measuring and testing tools, accessories) as well as the sequence of operations for working or manufacturing the workpiece.

Thus, the trainees avail of all the necessary information to begin their exercise-related work.

4.1. Instruction examples

What follows is a brief description of the individual instruction examples in order to give a survey of those workpieces on which the previously acquired knowledge can be practised.

Instruction example 12.1.

Centre punch and scribing punch

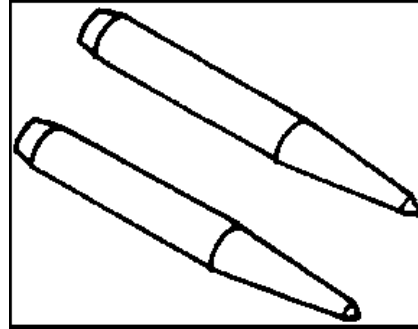

Figure

This exercise serve to practise the simple sharpening technique of worn punches as well as the production of these two kinds of punches.

Instruction example 12.2.

Steel scriber

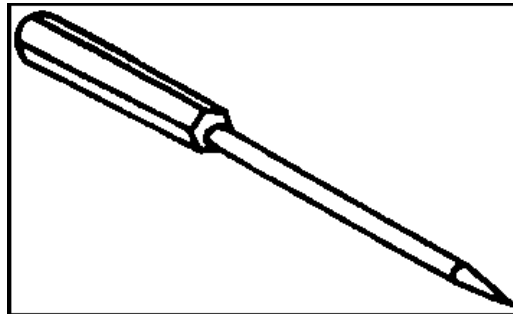

Figure

Similar to the practice involved in sharpening the punches, the trainees practise how to sharpen or to manufacture steel scribes professionally.

Instruction example 12.3.

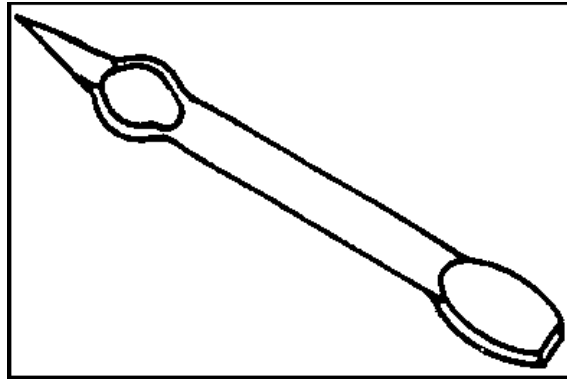
Screw driver**Figure**

The trainees practise the proper grinding of screw drivers. The instructor underlines the importance of a slightly hollow-ground blade.

Instruction example 12.4.

Flat chisel and cape chisel

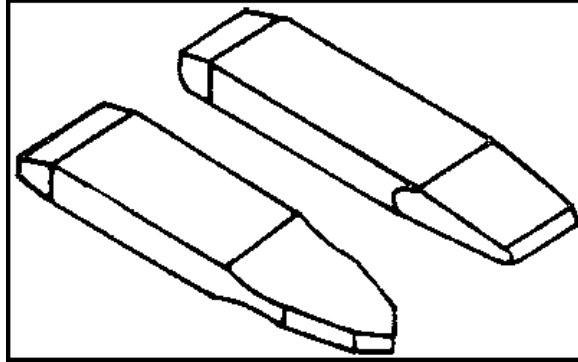

Figure

Based on the special requirements of parallelism and angularity of the cutting edges, the working technique of sharpening chisels is the main subject of this exercise.

Instruction 12.5.

Drills with standard drill point as well as flat drill point and centre point

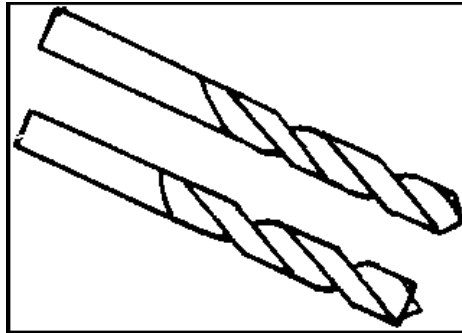

Figure

This exercise serves to practise grinding of the two main types of drill points of drills for steel. The instructor gives special hints for avoiding typical grinding errors.

4.2. Criteria for practical training

It is recommended to determine some crucial points of evaluation and supervision. The following criteria can serve as a guideline

- Does the trainee employ the appropriate grinding wheel?**
- Did he check the distances at the grinding machine?**
- Punch and scriber:
 - Does the trainee grind the tapered end with a horizontal position of the hand?****

- **Does the trainee grind the tapered end with a vertical position of the hand?**
- **Does the trainee cool the tool regularly?**
- **Does the trainee stick to the given dimensions?**
- **Flat chisel, cape chisel and scraper**
 - **Does the trainee grind the cutting edge through regular to- and for-movements?**
 - **Does he cool the tool sufficiently?**
 - **Does he comply with requirements for angularity and parallelism of the cutting edges with the outer edges?**
- **Drills**
 - **Does the trainee apply the main cutting edge of the drill in a horizontal position and with a setting angle from the left of about 58 degrees?**
 - **Does the trainee prese the drill upwards and to the right simultaneously?**
 - **Did the trainee avoid typical grinding faults?**

5. Caption and legends of the "Grinding of Simple Tools" transparencies series

Transparency no. 12.1. Construction of a grinding machine

(1) grinding machine

- 1 dripping vessel
- 2 drive motor
- 3 grinding wheels
- 4 protective hoods
- 5 support table
- 6 switch

(2) clamping mechanism of the grinding wheel

- 1 wheel
- 2 lead bushing
- 3 bored flange
- 4 cardboard disks
- 5 hexagonal nuts
- 6 washers

Transparency no. 12.2. Principles of the grinding process

(1) action of grinding

- 1 chip
- 2 cutting thickness
- 3 bonding agent
- 4 abrasive grain
- 5 workplace rake angle

(2) Kinds of movement associated with grinding

- 1 grinding wheel
- 2 workpiece
- 3 support

Transparency no. 12.3. Kinds of grinding wheels

- (1) flat wheel
- (2) dish wheel
- (3) cup wheel, straight
- (4) cup wheel, tapered









[Home](#) > [ar](#).[cn](#).[de](#).[en](#).[es](#).[fr](#).[id](#).[it](#).[ph](#).[po](#).[ru](#).[sw](#)



 **Manual Working of Material/Metal - Course: Manual working of metal. Methodical course-guide for instructors (Institut für Berufliche Entwicklung, 120 p.)**

  **Shearing**

-  **1. Objectives and Subject Matters of Vocational Training in Shearing Techniques**
-  **2. Organizational Preparations**
 -  **(introduction...)**
 -  **2.1. Planning the Training in Shearing Techniques**
 -  **2.2. Preparing the Instructions on Labour Safety**
 -  **2.3. Providing the Teaching Aids**

- **3.2.4. Providing the Working Means**
- **3. Recommendations Regarding Execution of Vocational Training in Shearing Techniques**
 - **(introduction...)**
 - **3.1. Introductory Instruction**
 - **3.2. Practical Exercises**
 - **3.3. Examples for Recapitulation and Control**

Manual Working of Material/Metal - Course: Manual working of metal. Methodical course-guide for instructors (Institut fr Berufliche Entwicklung, 120 p.)

Shearing

1. Objectives and Subject Matters of Vocational Training in Shearing Techniques

After having terminated the training, the trainees are to surely master the most common techniques of "shearing". For that purpose, the following objectives will have to be attained:

Objectives

- The trainees will have acquired profound knowledge about types and working means for shearing.**
- They will know how to master the different techniques used in shearing sheet metals and sections with various tools and machines.**
- They will have been enabled to select the appropriate tool as to sheet**

thickness and way of cut.

- **The trainees will know how to apply tools and machinery, while considering the health protection, labour safety and fire precaution measures.**
- **They will know how to assess the quality of their work.**

To achieve the aims required, the instructor has to impart the following subject matters:

Subject Matters***Knowledge***

- **Purpose of shearing**
- **Types and fields of application of tools and machinery**
- **General construction of shears**
- **Operating characteristics and techniques of shearing**
- **Process routines of shearing**
- **Instructions on labor safety**

Abilities

- Knowing how to operate mechanical shears and special machines to shear sheet metals and sections.

2. Organizational Preparations

To ensure a trouble-free course of instructions, exercises and teaching, it is necessary to organize a well-prepared training. For that purpose, the following measures are indispensable.

2.1. Planning the Training in Shearing Techniques

Proceeding from the entire hour volume, the times for the individual training sections of this didactic unit should be planned in a differentiated manner.

It is recommended to make a time schedule for the following training sections:

- for introduction in the techniques in the form of instruction**
- for demonstrations required**
- for instructions related to task in preparing the exercises**
- for executing the exercises**
- for recapitulations and controls**

In planning the time schedule, the following factors are to be taken into consideration additionally:

- Trainees' present state of education**
- Conditions of training**
- Trainees' future employment**

- Degree of difficulty of the training section

Key point of any training section is always the acquisition of skilled abilities and facilities to be acquired by exercises. The largest period of time should be allocated to them.

2.2. Preparing the Instructions on Labour Safety

Before the exercises start, a brief instruction should be given, comprising the proper handling of working means and recommendations as to avoiding accidents during work. The following key points have to be stressed particularly:

- Use gloves when transporting large sheet plates - risk of getting injured.**
- Only use sharp shears being in working order - blade clearance must be correctly set.**
- Do not work with your hands between the shear blades - risk of getting injured.**
- Hand-lever shears and plate shears to be operated by one person only. As for larger sheet metals and long sections, a second person may help shove the material trough from the side.**
- Correctly adjust the toe dog when working with lever shears and shearing machines.**
- Do not stay within the swivel range of hand lever during the shearing**

operation.

- **After finishing shearing on the hand-level shear, secure hand lever against dropping.**
- **Shear steel sections with section knives only.**
- **Only operate shearing machines after being instructed comprehensively. Observe the manufacturer's operating instructions exactly.**
- **At once, throw waste material into the waste container after shearing operation.**

After being instructed, the trainees have to confirm above recommendations with their signature in the control book.

2.3. Providing the Teaching Aids

- **The "Trainees' Handbook of Lessons - Shearing" will be distributed among the trainees according to their number.**
- **Essential illustrations from the "Trainees' Handbook of Lessons" should be used as visual aids (e.g. as pictures on flip charts, blockboards etc.).**
- **Workpieces that are sawed, chiseled or sheared should be provided as visual aids.**
- **Special tools the trainees do not know yet should be used as visual aids as**

well, as far as they can be transported.

- If transparencies on shearing are available, they should be included in the instruction in any case.

2.4. Providing the Working Means

- The "Instruction Examples for Practical Vocational Training - Shearing" as a theoretical basis for the exercises to be carried out are to be distributed among the trainees as to their number.

- The unmachined materials required for the exercises are to be prepared and made available in a sufficient quantity, using the given material stated in the "Instruction Examples for Practical Vocational Training".

- Check the workshop's complete outfit with tools, machines, measuring and testing means as well as auxiliaries according to the planned exercises.

- Recommended basic outfit:

- **Steel scribe, beam trammels, smooth files and bastard cut files**
- **Engineer's hammer, aluminium hammer**
- **Steel rule, caliper gauge**
- **Tinners' snip, tinners' through snip**
- **Curve shear, plate shear, hand-lever shear**
- **Vise, surface plate**

- Check serviceability of machines to be employed for shearing operation,

considering labour safety regulations before the exercises begin.

3. Recommendations Regarding Execution of Vocational Training in Shearing Techniques

The following sections contain proposals on how to arrange the trainees' instruction, the demonstration of the techniques as well as exercises and controls.

3.1. Introductory Instruction

The introductory instruction should be performed with the trainees in a class-room, if possible. During the instructions, attention has to be paid to the trainees' noting down necessary supplements or replies to questions in the "Trainees' Handbook of Lessons". With regard to the key points contained in the "Trainees' Handbook of Lessons" the instruction can be given as to the following subject matters.

Purpose of Shearing

At the beginning of instruction it is necessary to explain to the trainees the purpose of shearing compared to other cutting procedures - such as sawing and chiseling. In this connection, the advantages of shearing have to be clearly presented. A brief demonstration may support this fact.

3 trainees are to cut a sheet metal of 2 mm thickness (length and width of about 50 mm) into two halves.

These trainees receive the following tools and auxiliaries:

1st trainee - hand-type hack saw, vise

2nd trainee - flat chisel, engineer's hammer, surface plate

3rd trainee - hand-lever shear

The other trainees have the following observation tasks:

- **Time expenditure starting from setting the tool up to the cut sheet metal**
- **Comparing force consumption**
- **Assessing accuracy to size on scribed line**
- **Assessing expenditure for re-work due to the appearance of cutting line.**

If this demonstration cannot be conducted in the class-room, it should be effected - in any way - in the workshop before the exercise starts. In this case, the prepared demonstration workpieces should be shown during the instruction.

Tools and Machines

The following common shears are to be introduced in groups. Shears available in the workshop should be used as visual aid in this connection:

- **Tinners' snip, tinners' through snip, hole cutting shear**
- **Curve shear, plate shear, hand-lever shear**
- **Cutting tools**
- **Roller shear, electric hand-lever shear**
- **Hammer shear machine.**

The explanations concerning these tools and machines must contain the characteristic features of these working means, the special possibilities of

employment and their functional principles. Subsequently, the trainees should be in the position to select the most favourable shear when a certain work-piece to be sheared is mentioned after knowing the thickness of material as well as form and length of cut. The trainees should ask a few questions about this key point - for instance:

“With which shear is it most favourable to cut a circular disk out of a 3 mm thick sheet-metal plate?” Following this question-answer talk the trainees should solve in writing the respective task contained in the “Trainees' Handbook of Lessons”.

General Construction of Shears

With the help of a blackboard drawing as to “Figure 12” of the “Trainees' Handbook of Lessons” the angles and the blade clearance on shears can be descriptively explained now. It is necessary that the trainees know about the general construction of shears in order to be able to assess the serviceability of shears entrusted to them in the workshop and, if required, to perform minor adjustments or repairs of these working means.

Mode of Operation of Shears

The 3 stages of the shearing process should be briefly explained, while using figures 17 to 20 of the “Trainees' Handbook of Lessons” for drawing a panel sketch.

With the help of the joint face appearance, the trainees should be explicated the necessity of minor re-work (de-burring).

It should be stressed that sheared material edges would be very sharp and may

therefore cause injuries.

Shearing Techniques

The techniques - cutting-in, cutting-off, cutting-out and punching - are to be described in a general account in order to elucidate the differences of possible ways of cut.

Selected Technological Sequences of Shearing

Since the shearing process has a very simple work sequence, it is only necessary in this connection to demonstrate the handling of the shear in combination with the material to be cut. It should be particularly referred to the exact scribing, the correct alignment of the workpiece between the shear blades and to the observance of the right way of cut.

The following exemplary sequence will be described in the "Trainees' Handbook of Lessons":

- 1. Cutting in sheet metal with the tinnern's snip**
- 2. Cutting off sheet metal with the hand-lever shear**
- 3. Cutting off angular section with the hand-lever shear**

With the help of these examples it is very clearly explained which particularities have to be noted when sheets and sections are scribed and cut.

Hints on Labour Safety

During the shearing operation, incised wounds may occur very quickly, which can only be avoided by exactly observing the hints on labour safety and the regulations on how to operate tools and machines. The essential hints on labour safety are contained in the "Trainees' Handbook of Lessons" - they should be given very urgently.

3.2. Practical Exercises

Basically, the necessary hints on labour safety have to be given prior to the exercises. Subsequently, the trainees receive their workplaces and the equipment available in the workshop will be checked as to its serviceability.

It is recommended to start any exercise with a demonstration by the instructor in connection with an instruction related to the didactic example. Here, the trainees should be motivated to perform the exercises in good quality. Difficulties to be expected should be indicated. At the same time, rating key points are to be made known.

It is necessary that the instructor performs the exercise himself before. Only in this way does he know the difficulties arising during the operation.

The course of exercises may be effected in the sequence of the instruction examples proposed. With the help of the "Instruction Examples for Practical Vocational Training" 5 exercises can be carried out by using various tools. For that purpose, a list of materials (unmachined material, tools, measuring and testing instruments as well as auxiliaries), the work routine to carry out exercises and a descriptive work drawing are contained in the documentation "Instruction Examples...". Thus, the

trainees attain all the information required to implement the exercises purposefully.

To give a survey which practical pieces the knowledge previously imparted is to be applied to, the individual instruction examples will be briefly described hereinafter.

Instruction Examples

Instruction example 13.1. Smother and putty knife

The sheet-metal parts for a smoother and a putty knife are to be cut out with the thinners' snip and the tinnners' through snip.

(Figure 1)

Instruction example 13.2. Roof tiler trowel

Sheet parts for two different roof tiler trowels are to be cut out with the curve shear.

(Figure 2)

Instruction example 13.3. Smoothing trowel

The sheet part for a smoothing trowel is to be cut out with the mechanical plate shear.

(Figure 3)

Instruction example 13.4. Brick trowel

The sheet part for a brick trowel is to be cut out with the hand-lever shear.

(Figure 4)

Instruction example 13.5. Hinge-joint

Respectively an angle, a round and a flat are cut to length with the section blades of the hand-lever shear.

(Figure 5)

All the trainees may carry out the exercises at the same time, if the material prerequisites have been ensured (availability of sufficient working means).

In this case, the trainees can do each exercise individually and each trainee should have so much time as he would need. If there are not enough working means available, the trainees must be grouped, considering to be favourable to group them as to the use of the different tools.

Should the proposed instruction examples not be used for exercising, it is also possible to choose other practical pieces. Here, it should be noted that all the techniques previously talked about could also be exercised on these practical pieces.

Key Points of Practical Work

To execute the practical work it is recommendable to stipulate key points of observation and rating. They may be distinguished by the following criteria:

- **Do the trainees prepare their workplaces carefully?**
- **Are the mentioned tools placed ready and checked as to their serviceability?**
- **Are the workpieces scribed exactly?**
- **Do the trainees achieve the quality features required? Particularly:**
 - **Is the line of cut exactly on the scribed line?**
 - **Can transverse cracks and shoulders be seen at the line of cut?**
 - **Is the workpiece presented for control in a straightened and deburred state?**
 - **Are the workpieces accurate to size?**
- **Do the trainees apply the appropriate test method?**
- **Are the trainees able to correctly assess the quality of their work themselves?**
- **Are the trainees observing the labour safety regulations?**

3.3. Examples for Recapitulation and Control

Tasks have been compiled in this section to strengthen and revise knowledge and abilities acquired so far. Tasks also contained in the "Trainees' Handbook of Lessons" have been marked with the letter "A".

1. What is the purpose of shearing?

"A" (*Sheet metals and sections are cut in a non-chip, straight-lined or curve-shaped way.*)

2. Which are the advantages of shearing compared to sawing?

"A" (No metal is removed from the material by cutting, the scribed line can be exactly followed, joint faces require little re-work, shearing process is fast, way of cut may be straight-lined or curve-shaped.)

3. How are shearing techniques differentiated?

"A" (cutting in, cutting off, cutting out, punching)

4. Which cuts can be made with the tinner's snip?

"A" (Short straight-lined and short curve-shaped cuts on thin sheet metals.)

5. For which cuts is the tinner's through snip employed?

"A" (Straight longer cuts on thin sheets.)

6. For which cuts is the curve shear employed?

"A" (Circular and curve-shaped cuts on thin and medium-thick sheets.)

7. For which cuts is the plate shear used?

"A" (Long cuts on thin sheets.)

8. For which cuts is the hand-lever shear used?

"A" (Short straight-lined and curve-shaped cuts on medium-thick sheets and sections.)

9. Why have the shear knives a great wedge angle?

"A" (So that they are sufficiently stable and the blade edges do not break out so quickly.)

10. Why is it necessary to keep a blade clearance?

"A" (So that the blade edges do not rub on each other and get dull.)

11. What will happen when too great a blade clearance has been adjusted?

"A" (The sheet will be bent off during the shearing operation.)

12. What is the task of the dog on the lever-type shear and shearing machine?

"A" (Keeping the sheet metal in horizontal position to avoid pitching down.)

13. Why is an aperture angle of 15° important during the shearing process?

"A" (To prevent the workpiece from being pushed out of the shear.)

14. In which stages is the shearing process performed?

"A" (Notching, cutting and tearing)

15. What is the difference between the cutting-out and punching techniques?

"A" (Cutting-out - material being cut out is the workpiece; Punching - material being punched is scrap.)

16. What is to be expected in the sheet when the shear knives are completely closed?

"A" (Transverse cracks developed the end of cut.)

17. Why is the scrap side of a sheet to be situated on the right-hand side?

"A" (On shearing, the upper shear knife presses the right-hand sheet part downwards, cuts bends or twists it.)

18. Why must steel sections be cut in section knives?

"A" (Section knives are adapted to the steel section and make a clean shearing

possible. They are more stable than plane shear blades.)

19. What will happen when steel sections are cut on plane shear blades?

"A" (Cutting edges break out.)

20. Why must the hand lever be arrested on the hand-lever shear after the shearing operation?

"A" (Because it may fall down - risk of getting injured.)

21. Why must the rendered waste material be thrown in the waste container immediately?

"A" (Because the cutting residues have been bent and are very sharp-edged - risk of getting injured.)

