

[Home](#) > [ar.cn.de.en.es.fr.id.it.ph.po.ru.sw](#)

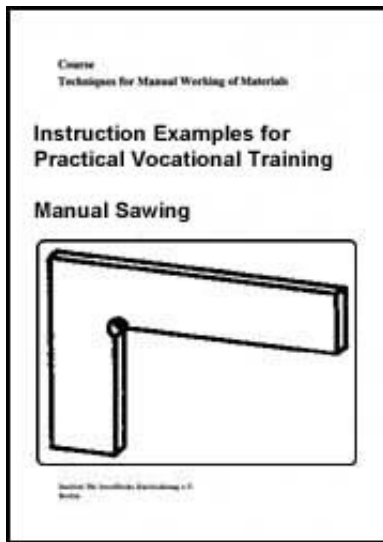

➔ **Manual Sawing - Course: Technique for manual working of materials. Instruction examples for practical vocational training (Institut fr Berufliche Entwicklung, 31 p.)**

(introduction...)

Introduction

Instruction example 4.1. Spacers and pin drifts

Instruction example 4.2. Stands and supports

Instruction example 4.5. Container

Instruction example 4.4. Vee-shaped attachment

Instruction example 4.5. Steel square

Instruction example 4.6. Angle-steel frame table

Instruction example 4.7. Wall-shelf bracket



[Home](#) > [ar.cn.de.en.es.fr.id.it.ph.po.ru.sw](#)

Manual Sawing - Course: Technique for manual working of materials. Instruction examples for practical vocational training (Institut fr Berufliche Entwicklung, 31 p.)





➔ **(introduction...)**

Introduction

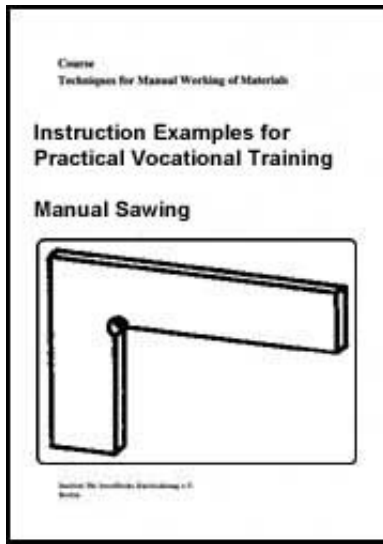
Instruction example 4.1. Spacers and pin drifts

Instruction example 4.2. Stands and supports



-  **Instruction example 4.5. Container**
-  **Instruction example 4.4. Vee-shaped attachment**
-  **Instruction example 4.5. Steel square**
-  **Instruction example 4.6. Angle-steel frame table**
-  **Instruction example 4.7. Wall-shelf bracket**

**Institut für berufliche Entwicklung e.V.
Berlin**

**Original title:
Lehrbeispiele für die berufspraktische Ausbildung
"Sagen von Hand"**

Author: B. Zierenberg

First edition © IBE

**Institut für berufliche Entwicklung e.V.
Parkstraße 23
13187 Berlin**

Order No.: 90-33-3104/2



[Home](#) > [ar](#).[cn](#).[de](#).[en](#).[es](#).[fr](#).[id](#).[it](#).[ph](#).[po](#).[ru](#).[sw](#)

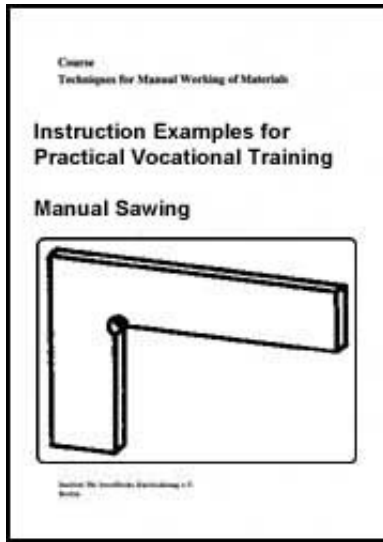

 **Manual Sawing - Course: Technique for manual working of materials. Instruction examples for practical vocational training (Institut fr Berufliche Entwicklung, 31 p.)**

 **(introduction...)**

  **Introduction**

 **Instruction example 4.1. Spacers and pin drifts**

 **Instruction example 4.2. Stands and supports**

 **Instruction example 4.5. Container**

 **Instruction example 4.4. Vee-shaped attachment**

 **Instruction example 4.5. Steel square**

 **Instruction example 4.6. Angle-steel frame table**

 **Instruction example 4.7. Wall-shelf bracket**

Introduction

The present material contains 7 selected instruction examples which are intended to help practising the main techniques of manual sawing with increasing level of difficulties. This includes straight, angular and parallel cuts - from simple cutting-off of flat and cylindrical parts as well as of various sections up to the manufacture of complex parts.

In order to facilitate the preparation and execution of the work, the necessary materials, measuring and testing tools, hand tools and accessories are stated for each training example. Moreover, knowledge required in addition to knowledge of manual sawing is mentioned.

The sequence of operations given for each instruction example includes the necessary steps for the production of the relevant workpiece.

For each instruction example a working drawing is attached showing the required shapes and dimensions of the workpiece.

All workpieces produced may be used in the workshop for practical purposes.

Spacers and Vee-shaped attachments are required for various vice work; pin drifts of nonferrous metals (copper and brass) are necessary accessories for pinning and drifting work; steel squares may be used by the trainees as testing tools.

Angle-steel frames with inserted steel or wooden plates and provided with supports are suitable tables for storing purposes.

Wall-shelf brackets are necessary supporting elements for the manufacture of wall shelves for the workshop.

**Explanation to the specification of material:
Steel is specified according to the value of its tensile strength in the unit "Megapascal" (MPa).**



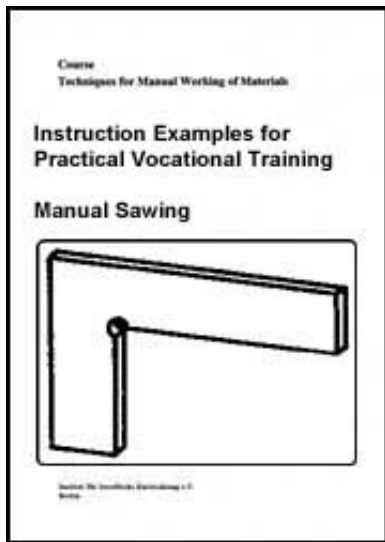

 **Manual Sawing - Course: Technique for manual working of materials. Instruction examples for practical vocational training (Institut für Berufliche Entwicklung, 31 p.)**

 **(introduction...)**

 **Introduction**

  **Instruction example 4.1. Spacers and pin drifts**

 **Instruction example 4.2. Stands and supports**

 **Instruction example 4.5. Container**

 **Instruction example 4.4. Vee-shaped attachment**

 **Instruction example 4.5. Steel square**

 **Instruction example 4.6. Angle-steel frame table**

 **Instruction example 4.7. Wall-shelf bracket**

Instruction example 4.1. Spacers and pin drifts

To practise simple cutting-off of sectional steel and other materials.

Material

- Flat steel (340 MPa)

Thickness: 15 mm

Width: 25 mm

- Flat aluminium bars

Thickness: 5 mm

Width: 40 mm

- Round copper and brass bars e.g. 6 and 10 mm diameter, any length.

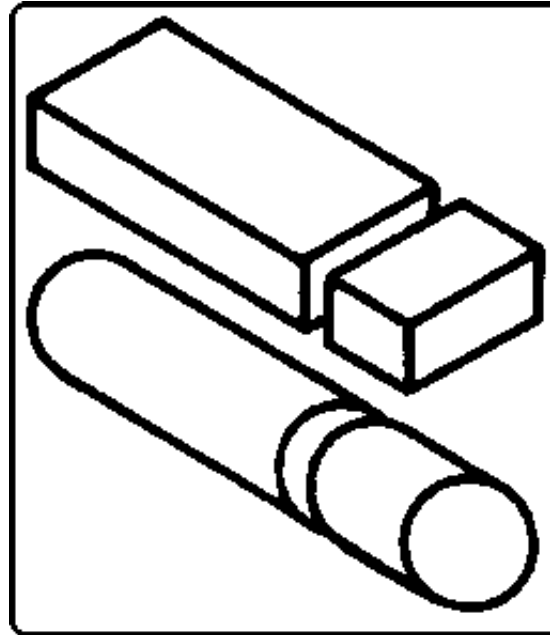

Figure

Hand tools

Steel scriber, mark-out punch, engineers' hammer, hand hacksaw with various saw blade types (coarse and normal tooth pitch), smooth-cut file 200 mm (flat).

Measuring and testing tools

Steel measuring tool, try square.

Accessories

Vice, cutting oil, horizontal Vee-shaped attachments.

Required previous knowledge

Reading of drawings, measuring and testing, scribing and prick-punching.

Sequence of operations	Comments
1. Arrange the working place, prepare the working materials.	- Check for completeness.
2. Scribe and prick-punch flat steel to 120 length.	- Part (1) Datum edge to be flat and at right angle (try square).
3. Clamp workpiece in vice and start sawing with small starting-cut sawing angle.	- Use saw blade with normal tooth pitch. - File guiding kerf, it necessary.
4. Saw-off with constant cutting movement, then remove burrs.	- Provide saw blade with cutting oil. - Use total length of saw blade.
5. Prepare and saw-off flat aluminium bar in the same manner.	- Part (2) - Use saw blade with coarse tooth pitch.
6. Scribe round copper and brass bars and clamp them in vice.	- Parts (3) and (4) - Use suitable attachments for horizontal clamping.
7. Saw-off at scribed line in one pass and remove	

7. Saw-off at scribed line in one pass and remove

burrs.

8. Final inspection.

- Straightness of cut.

To continue practising, if necessary

Saw-off other flat stock and round bars of different diameters.

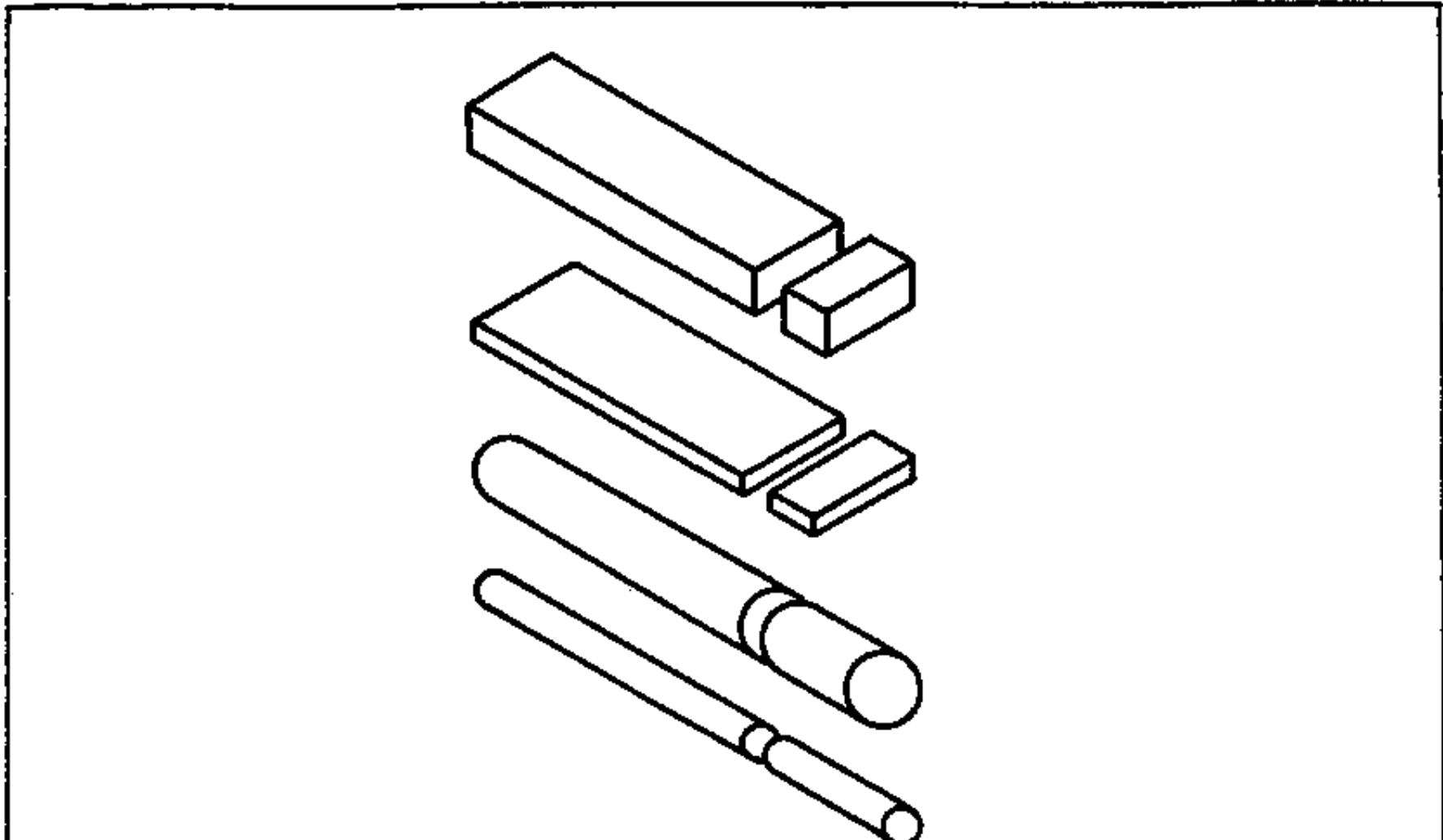

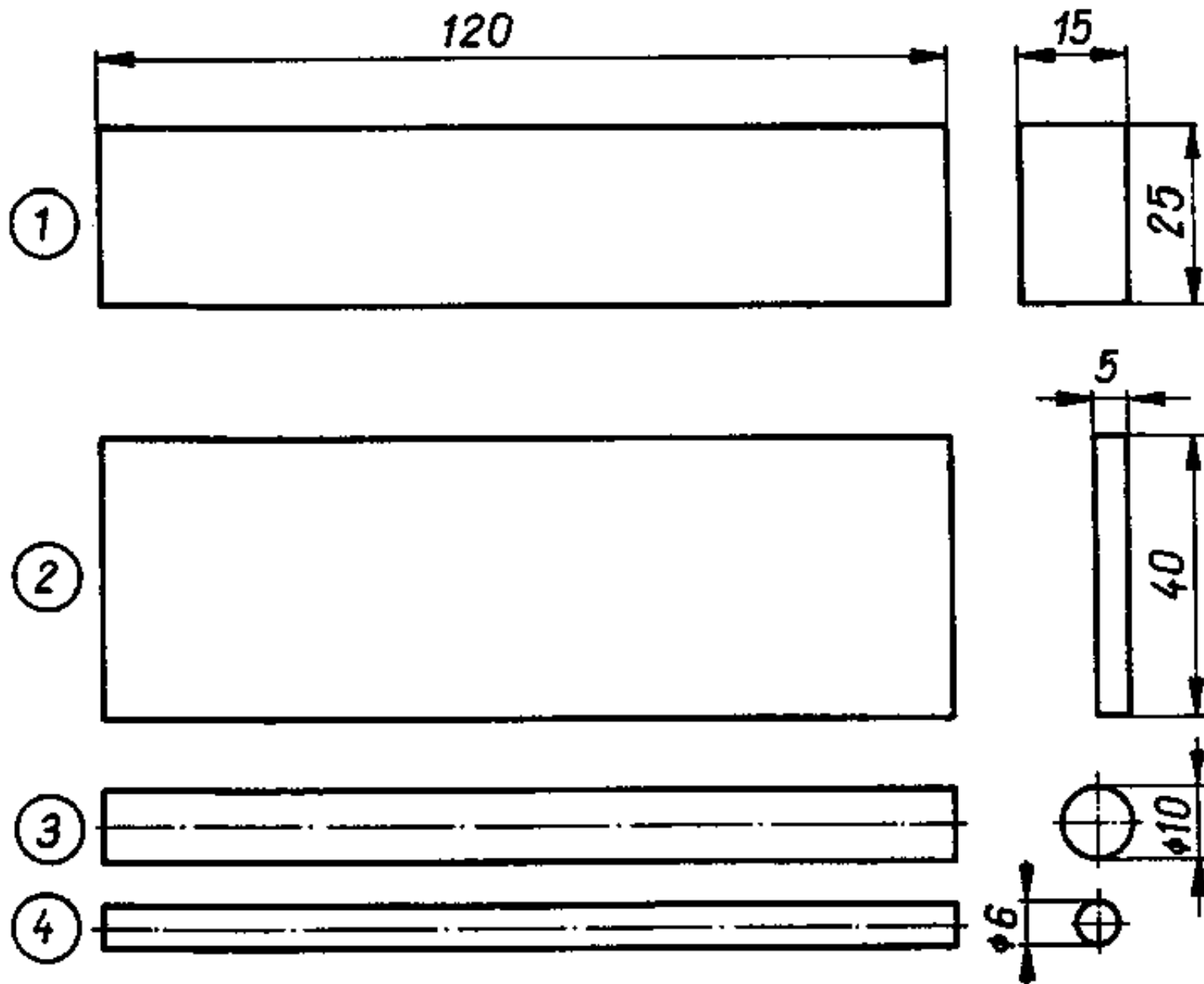

			4.1.
	Spacers and pin drifts		3104

Spacers and pin drifts



[Home](#) > [ar](#).[cn](#).[de](#).[en](#).[es](#).[fr](#).[id](#).[it](#).[ph](#).[po](#).[ru](#).[sw](#)

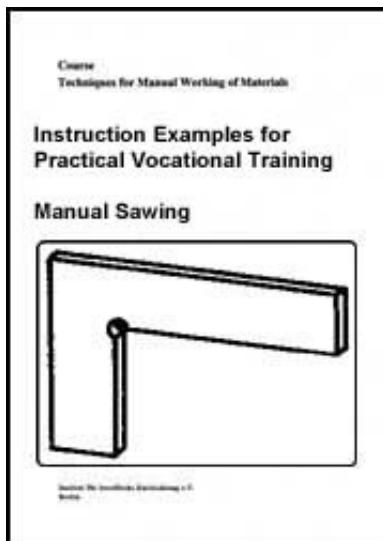

 **Manual Sawing - Course: Technique for manual working of materials. Instruction examples for practical vocational training (Institut fr Berufliche Entwicklung, 31 p.)**

 **(introduction...)**

 **Introduction**

 **Instruction example 4.1. Spacers and pin drifts**

  **Instruction example 4.2. Stands and supports**

 **Instruction example 4.5. Container**

 **Instruction example 4.4. Vee-shaped attachment**

 **Instruction example 4.5. Steel square**

 **Instruction example 4.6. Angle-steel frame table**

 **Instruction example 4.7. Wall-shelf bracket**

Instruction example 4.2. Stands and supports

To practise straight saw-off cuts in several steps on U-sections and tubes. U-sections may be used as basic bodies for drill stands, tubes as supports (table legs), training example 4.6.

Material

U-sections of steel (340 MPa)

Web width: 80 mm

Flange height: 45 mm

Steel tube (340 MPa)

25 mm diameter

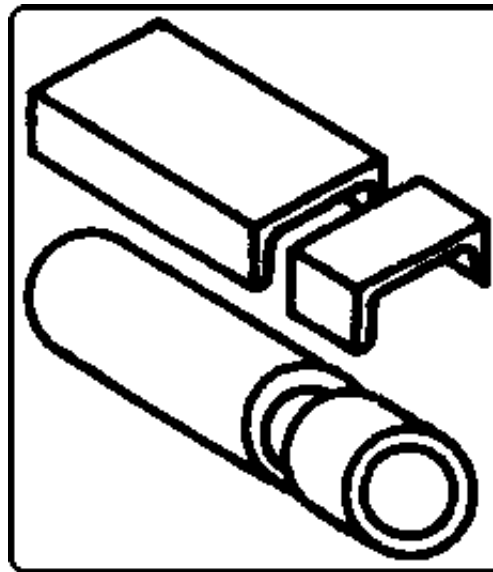

Figure

Hand tools

Steel scribe, hand hacksaw (saw blade of normal tooth pitch), smooth-cut file

200 mm (flat), mark-out punch, engineers' hammer.

Measuring and testing tools

Steel measuring tool, try square.

Accessories

Vice, surface plate, spacer (wooden block) for clamping of U-section, horizontal Vee-shaped attachment suitable for tube diameter, cutting oil.

Required previous knowledge

Reading of drawings, measuring and testing, scribing and prick-punching.

Sequence of operations	Comments
1. Arrange the working place, prepare the working materials.	- Check for completeness.
2. Scribe U-section for 120 mm length using try square and steel measuring tool, prick-punch scribedline.	- File datum edge, if end face is not flat.
3. Clamp workpiece in vice at web using suitable attachment and file guiding kerf at upper face (flange).	- Part (1)
4. Saw until upper face (flange) is cut off, then re-clamp and saw web, then re-clamp and saw off other flange, remove burrs.	- Use total length of saw blade.
5. Clamp steel tube in vice in horizontal position using Vee-shaped attachment. Scribe length as specified and file guiding kerf.	- Length to be specified by the

	instructor.
6. Saw until saw blade cuts off inner wall, then slightly turn tube and continue sawing.	- Part (2)
7. Saw off the tube constantly turning it.	
8. Final inspection.	- Straightness of cut.

To continue practising, if necessary

Prepare several U-sections for different drill stands (training examples 2.3 and 7.4).

Saw off additional tubes for supports (training example 4.6).

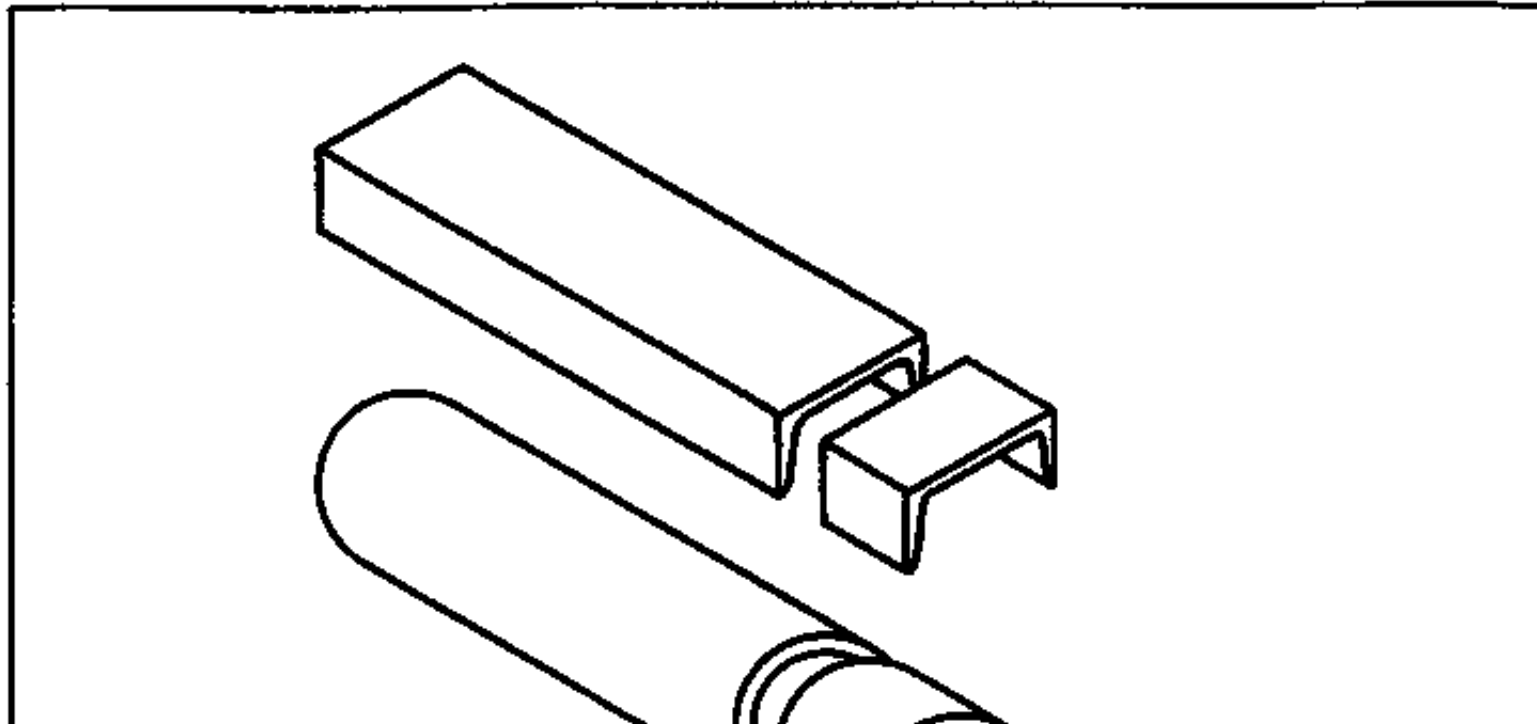

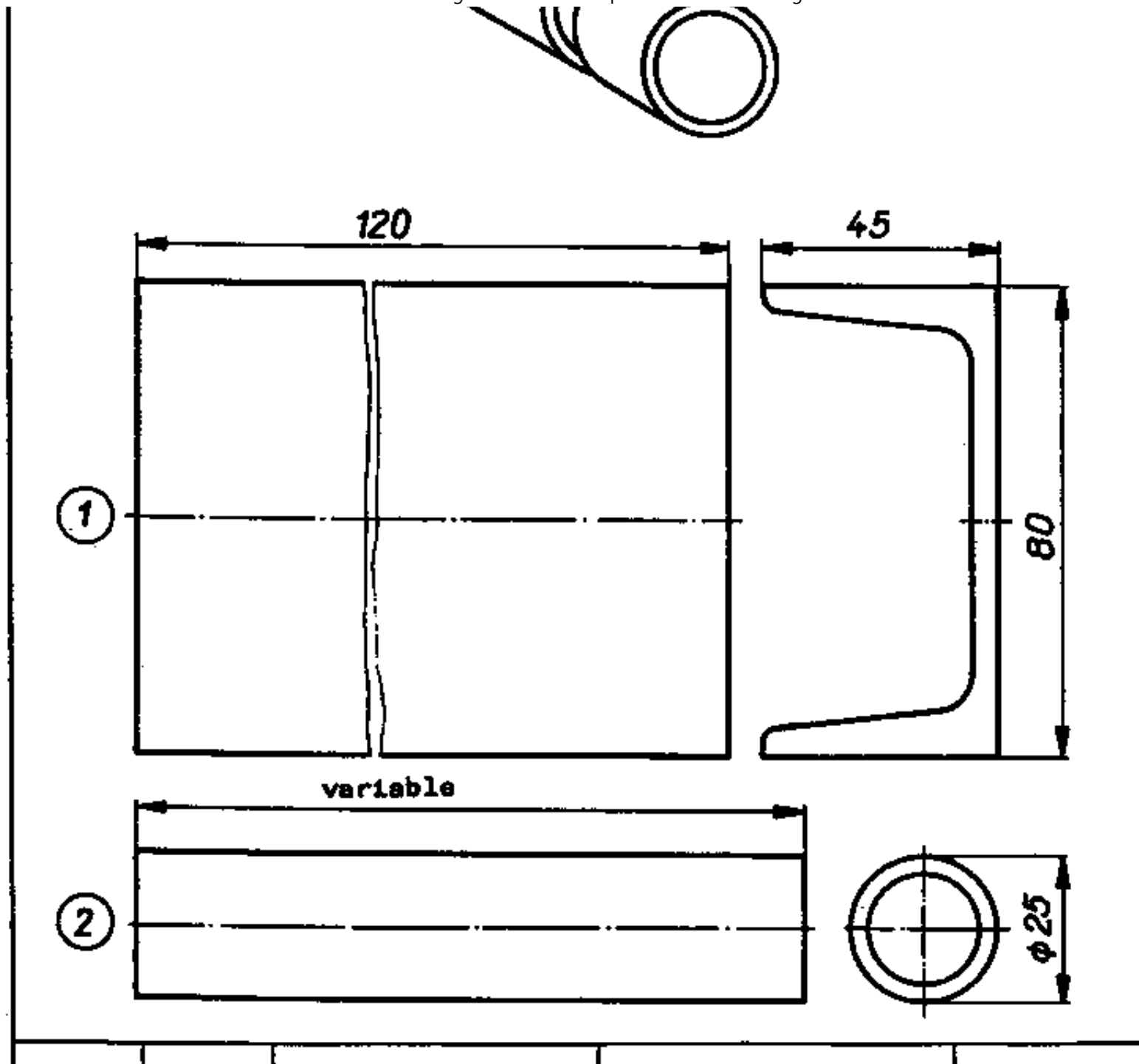

			4.2.
	Stands and supports		3104

Stands and supports



[Home](#) > [ar.cn.de.en.es.fr.id.it.ph.po.ru.sw](#)

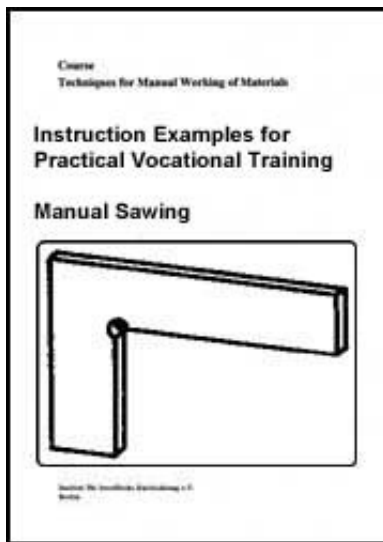

 **Manual Sawing - Course: Technique for manual working of materials. Instruction examples for practical vocational training (Institut fr Berufliche Entwicklung, 31 p.)**

 **(introduction...)**

 **Introduction**

 **Instruction example 4.1. Spacers and pin drifts**

 **Instruction example 4.2. Stands and supports**

 **➔ Instruction example 4.5. Container**

 **Instruction example 4.4. Vee-shaped attachment**

 **Instruction example 4.5. Steel square**

 **Instruction example 4.6. Angle-steel frame table**

 **Instruction example 4.7. Wall-shelf bracket**

Instruction example 4.5. Container

To practise mitre cuts on tubes and sheets of steel or light metal to specified size.

Material

- **Steel or aluminium tube**
45 dia. x 100 mm long
(wall thickness 2.5 mm).

- **Steel sheet or aluminium sheet**
Thickness: 4 mm
Width: 70 mm
Length: 70 mm.

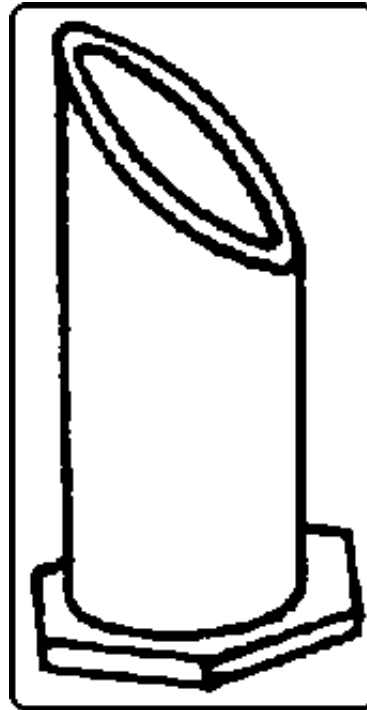

Figure

Hand tools

Steel scriber, mark-out punch, engineers' hammer, dividers, hand hacksaw, smooth-cut file 200 mm (half-round).

Measuring and testing tools

Steel measuring tool, protractor, try square.

Accessories

Vice, Vee-shaped attachment to suit tube diameter, surface plate, cutting oil.

Required previous knowledge

Reading of drawings, measuring and testing, scribing and prick-punching.

Sequence of operations	Comments
1. Arrange the working place, prepare the working materials.	- Check for completeness.
2. Clamp steel tube horizontally in vice using Vee-shaped attachment, scribe one end face with protractor (45° setting) and steel scriber.	- Part (1)
3. File guiding kerf and saw off tube in one pass, remove burrs (inside and outside).	- Provide saw blade with cutting oil.
4. Scribe 100 mm length and saw off other face end with straight cut (check with try square), remove burrs*	
5. Prick-punch sheet at centre, use punch mark as supporting point for	- Part (2)

dividers and draw circle of 68 diameter. Use same setting of dividers to mark step by step the six points on the circle, connect such points.

6. Clamp sheet vertically in vice and saw at scribed line, remove burrs.

- Use small starting-cut sawing angle!

7. Final inspection.

- Dimensions and straightness of cut.

Completion

Glue, solder or weld tube onto metal sheet.

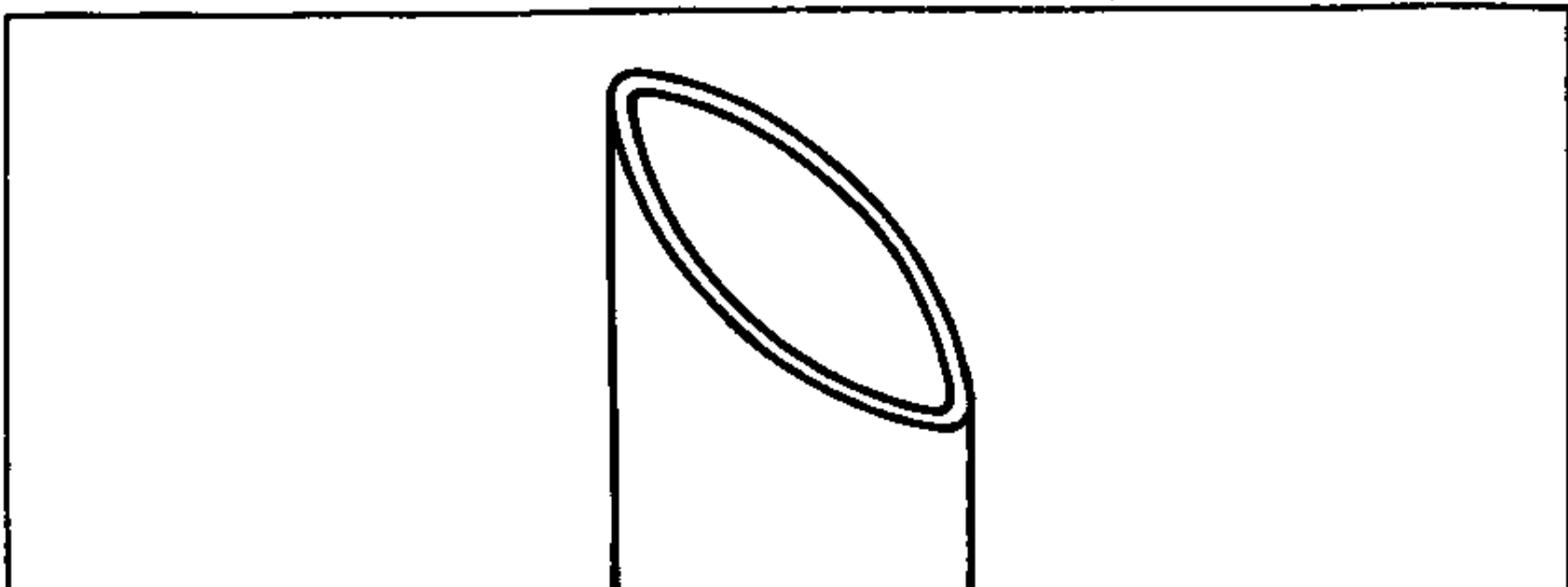

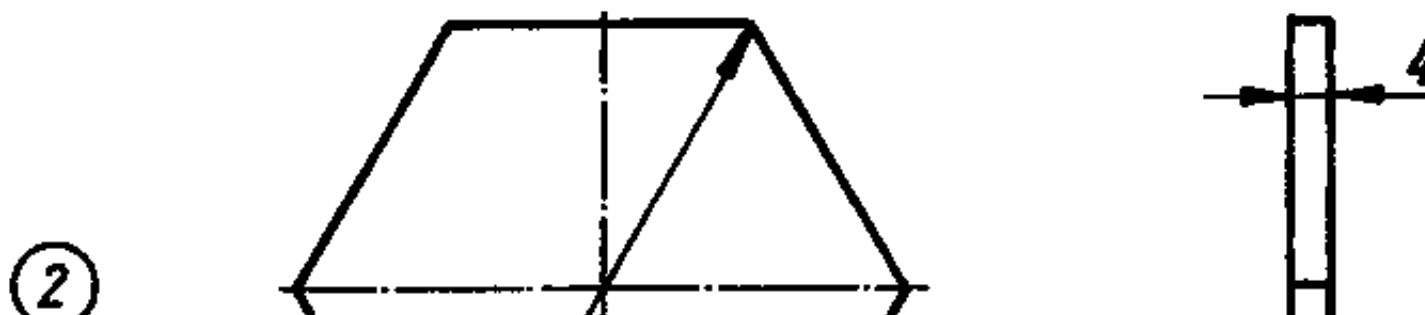
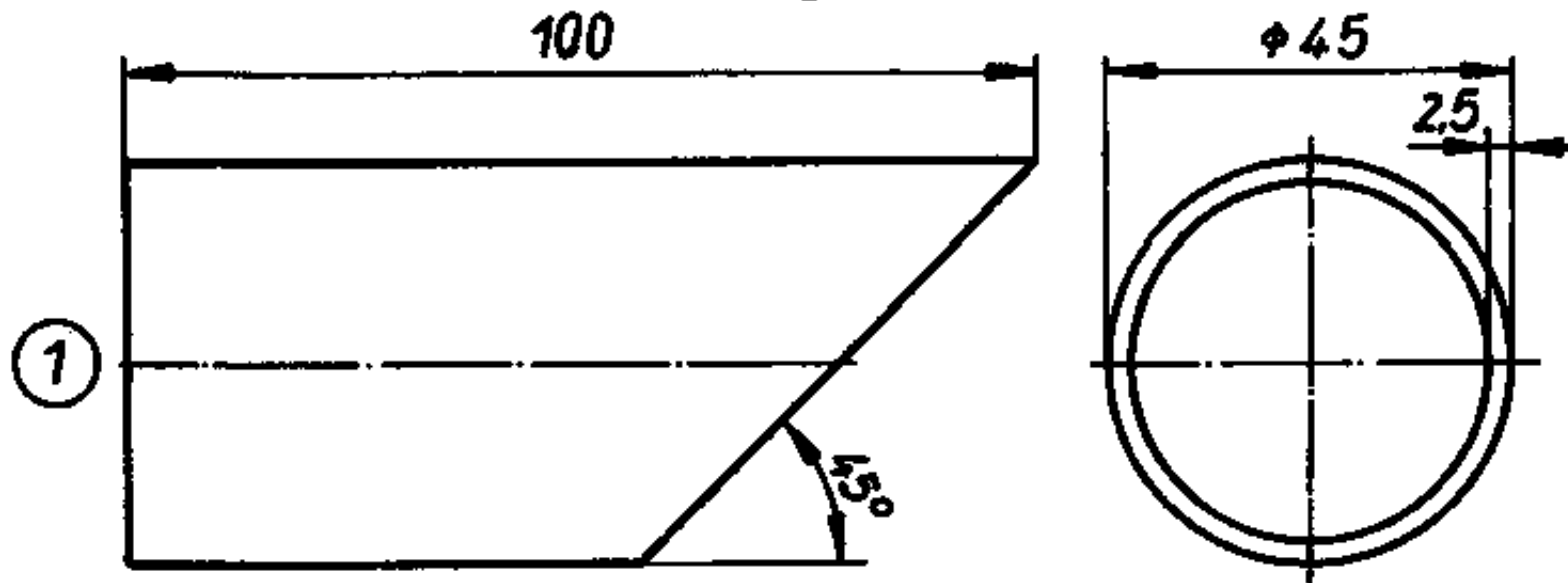
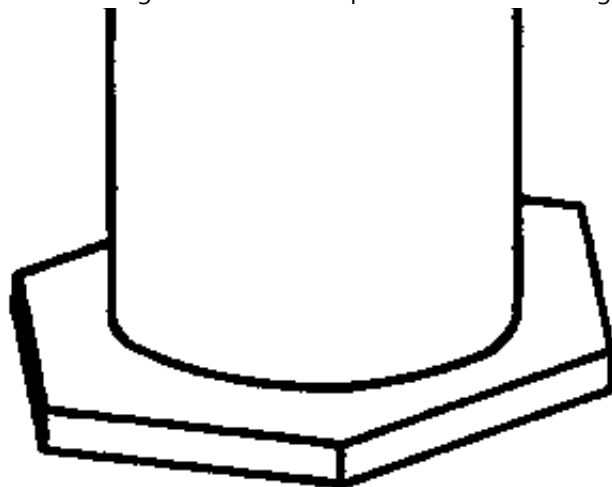

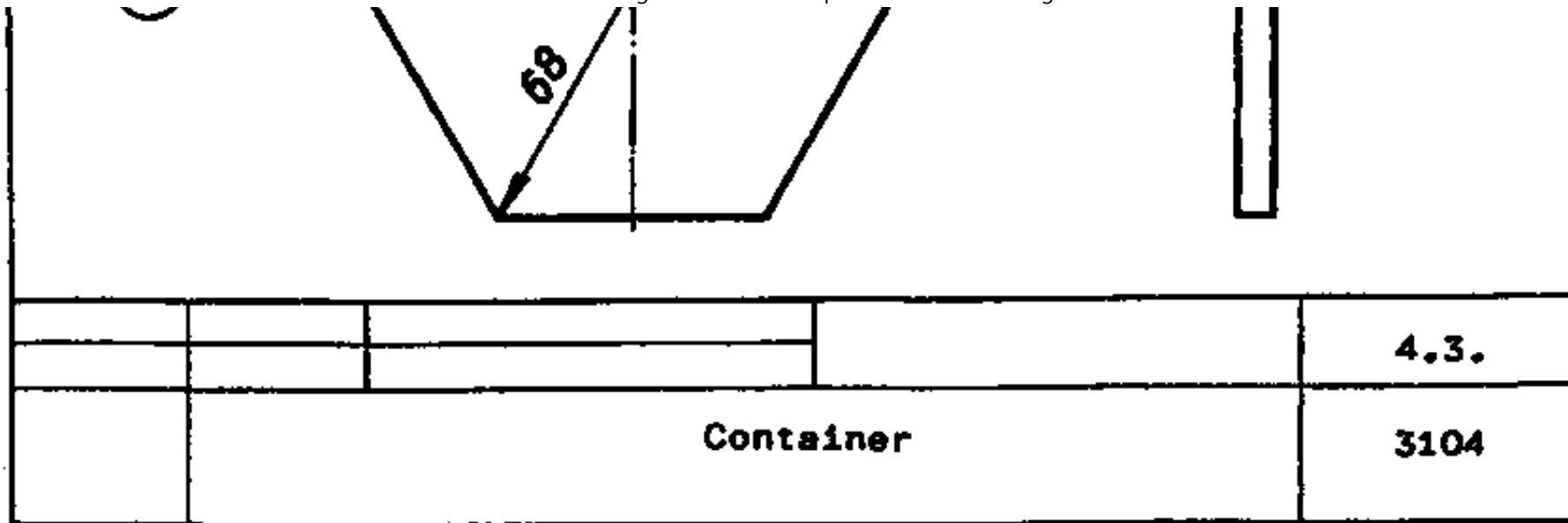

Container



[Home](#) > [ar](#).[cn](#).[de](#).[en](#).[es](#).[fr](#).[id](#).[it](#).[ph](#).[po](#).[ru](#).[sw](#)

 **Manual Sawing - Course: Technique for manual working of materials. Instruction examples for practical vocational training (Institut fr Berufliche Entwicklung, 31 p.)**

 **(introduction...)**

 **Introduction**



 **Instruction example 4.1. Spacers and pin drifts**

 **Instruction example 4.2. Stands and supports**

 **Instruction example 4.5. Container**

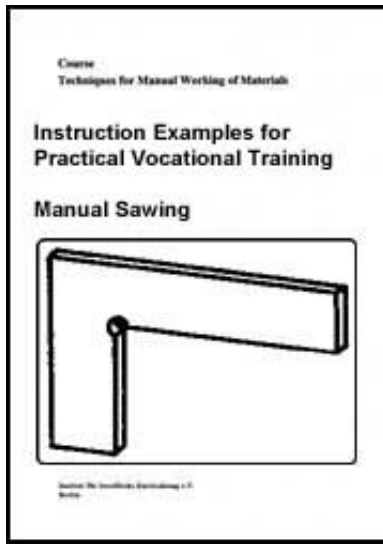
  **Instruction example 4.4. Vee-shaped attachment**



-  **Instruction example 4.5. Steel square**
-  **Instruction example 4.6. Angle-steel frame table**
-  **Instruction example 4.7. Wall-shelf bracket**

Instruction example 4.4. Vee-shaped attachment

To practise straight long cuts on sheet metal and angular cuts on solid square bar steel.

Material

- 2 x sheet steel (380 MPa)

Thickness: 2.5 mm

Width: 85 mm

Length: 125 mm

- 2 x square bar steel (420 MPa)

Thickness: 30 mm

Length: 125 mm

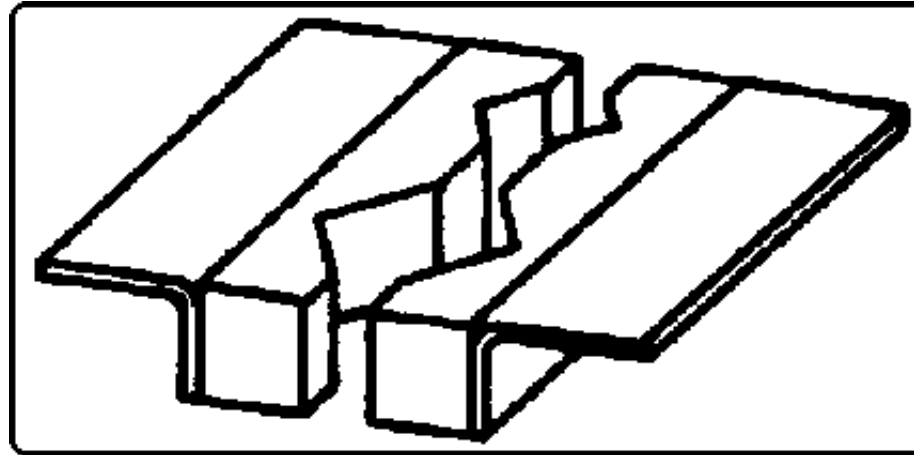

Figure

Hand tools

Steel scribe, mark-out punch, engineers' hammer, aluminium hammer, hand hacksaw (saw blade with normal tooth pitch), smooth-cut file 250 mm (flat).

Measuring and testing tools

Steel measuring tool, protractor, try square.

Accessories

Vice, surface plate, cutting oil.

Required previous knowledge

Reading of drawings, measuring and testing, scribing and prick-punching.

1. Arrange the working place, prepare the working materials.	- Check for completeness.
2. Scribe sheet steel and saw to length and width, smooth edges with file.	- Part (1) Check for squareness (try square).
3. Saw square bar steel to length, smooth and face with file.	- Check for squareness.
4. Scribe, prick-punch and saw out angles.	- Part (2) Provide saw blade with cutting oil.
5. Smooth inner angle faces with file, chamfer all edges.	
6. Final inspection.	- Dimensions, appearance.

Completion

Connect sheets with square steel by screwing or rivetting (to be specified by the instructor).

Clamp parts in vice and bend sheets by hammering with aluminium hammer.

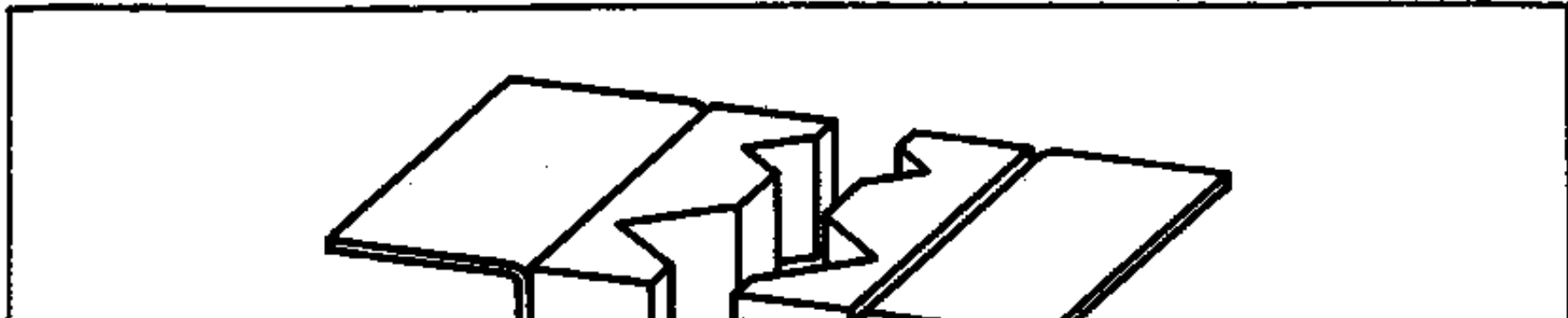

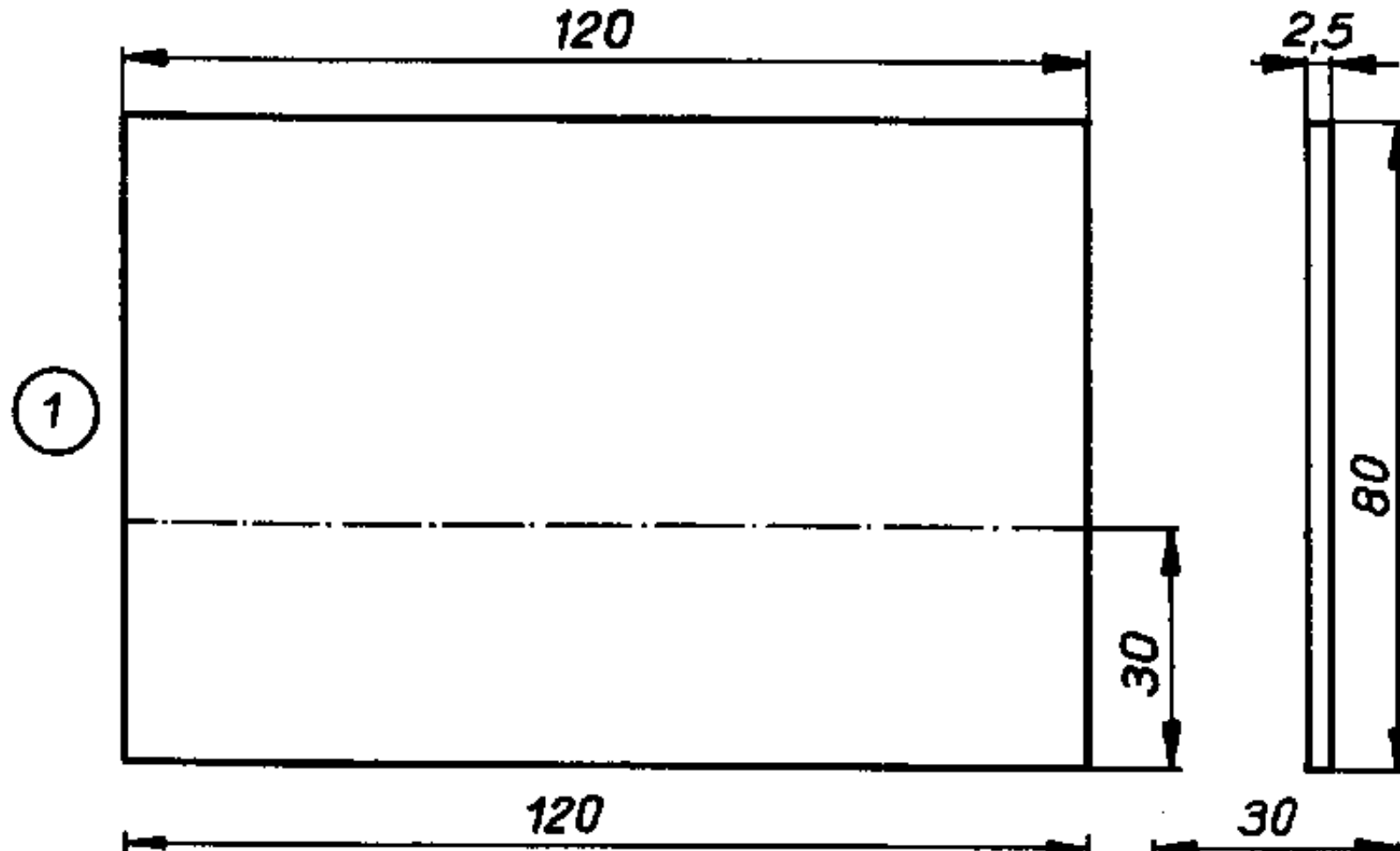

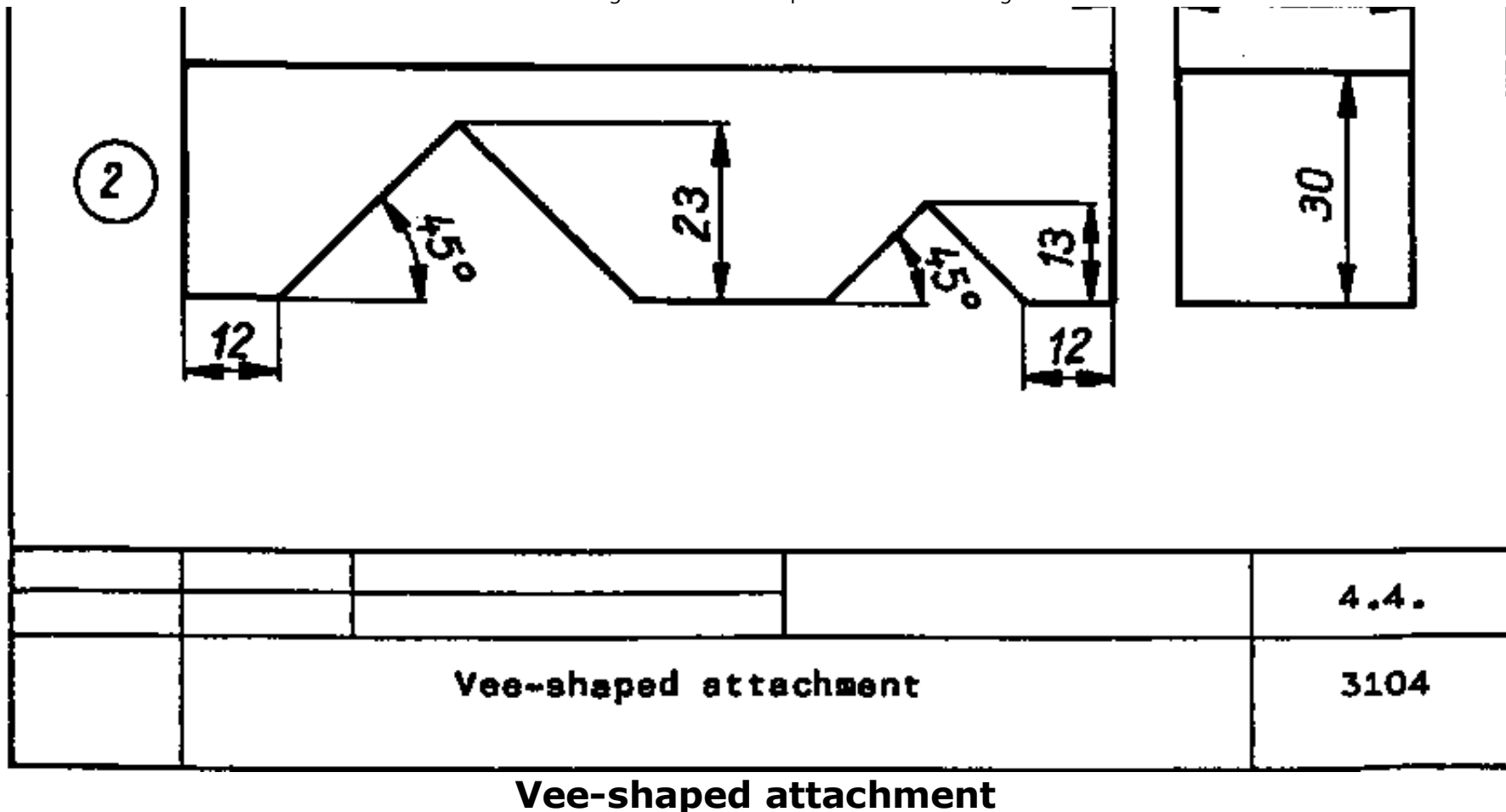







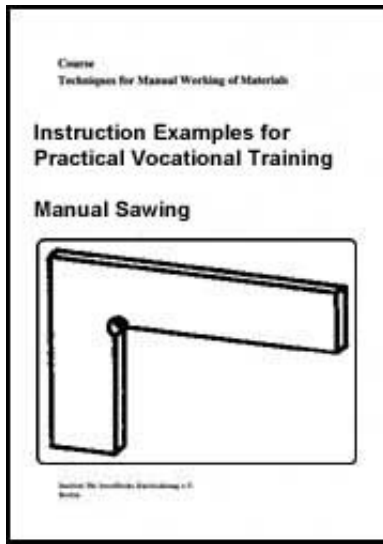

[Home](#) > [ar](#).[cn](#).[de](#).[en](#).[es](#).[fr](#).[id](#).[it](#).[ph](#).[po](#).[ru](#).[sw](#)

 **Manual Sawing - Course: Technique for manual working of materials. Instruction examples for practical vocational training (Institut fr Berufliche Entwicklung, 31 p.)**

 **(introduction...)**



-  **Introduction**
-  **Instruction example 4.1. Spacers and pin drifts**
-  **Instruction example 4.2. Stands and supports**
-  **Instruction example 4.5. Container**
-  **Instruction example 4.4. Vee-shaped attachment**
-  **Instruction example 4.5. Steel square**
-  **Instruction example 4.6. Angle-steel frame table**
-  **Instruction example 4.7. Wall-shelf bracket**

Instruction example 4.5. Steel square

To practise straight long sawing cuts of high precision on sheet steel.

Material

Sheet steel (higher-strength or hardenable steel)

Thickness: 5 mm

Width: 80 mm

Length: 120 mm

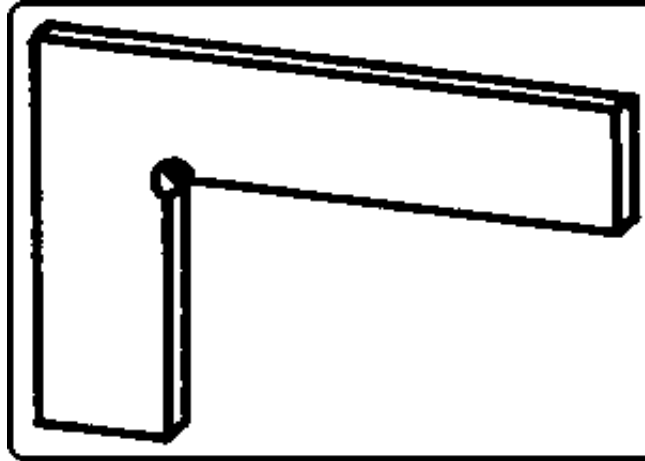

Figure

Hand tools

Steel scribe, prick punch, engineers' hammer, 4 mm dia. drill, hand hacksaw (saw blade of normal tooth pitch), smooth-cut file 250 mm (flat).

Measuring and testing tools

Steel measuring tool, try square.

Accessories

Vice, surface plate, copper sulphate solution, cutting oil.

Required previous knowledge

Reading of drawings, measuring and testing, scribing and prick-punching.

1. Arrange the working place, prepare the working materials.	- Check for completeness.
2. File steel sheet at one longitudinal side and one end side flat and at right angle to each other to serve as datum edges.	
3. Coat sheet with copper sulphate solution, after drying scribe inside edges and provide with check punch marks.	- Danger! Copper sulphate solution is toxic!
4. Prick-punch point of intersection of inside edges and drill with 4 mm dia. drill, remove burrs.	- 1400 r.p.m. speed Drill under supervision of instructor only!
5. Clamp sheet in vice so as to permit vertical sawing cut. At a distance of 1 mm to the scribed line saw out inside edges first and then end faces of the workpiece.	- Provide saw blade with cutting oil.
6. Final inspection.	- Dimensions and straightness of cut.

Completion

Produce final form by filing, check with bevelled edge square, have inside and outside edges hardened.

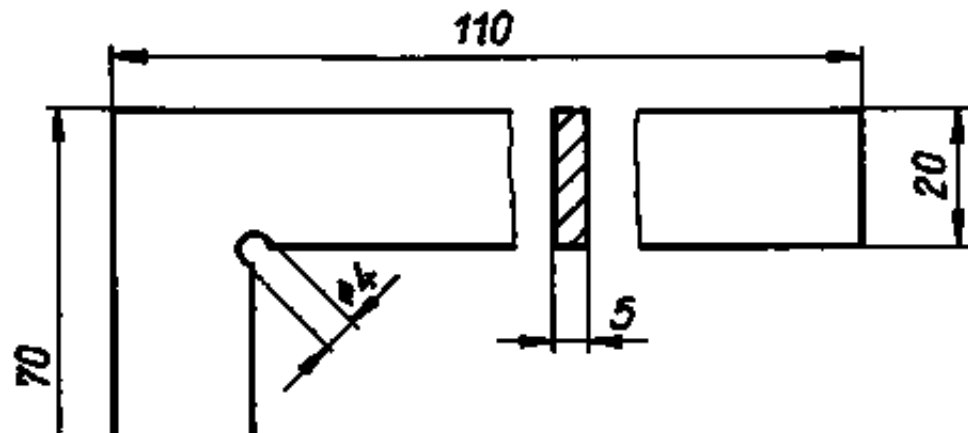
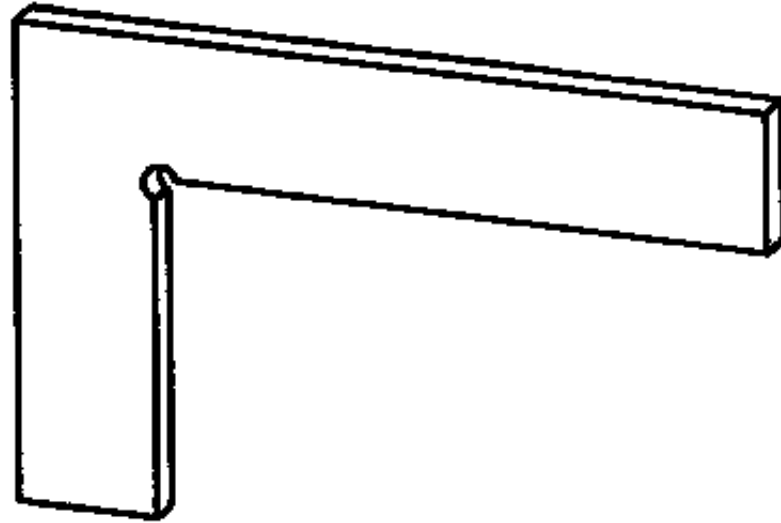

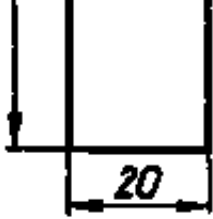

				4.5.
	Steel square			3104

Steel square



[Home](#) > [ar](#).[cn](#).[de](#).[en](#).[es](#).[fr](#).[id](#).[it](#).[ph](#).[po](#).[ru](#).[sw](#)

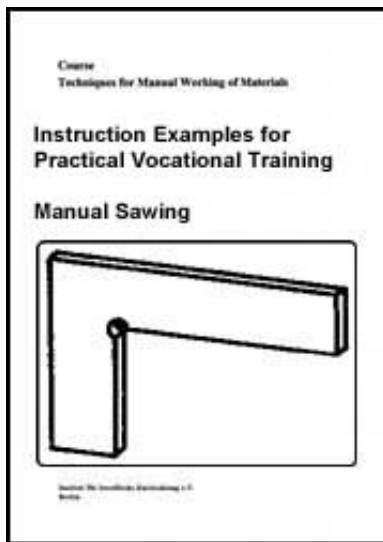

 **Manual Sawing - Course: Technique for manual working of materials. Instruction examples for practical vocational training (Institut für Berufliche Entwicklung, 31 p.)**

 **(introduction...)**



 **Introduction**

 **Instruction example 4.1. Spacers and pin drifts**

 **Instruction example 4.2. Stands and supports**

 **Instruction example 4.5. Container**

 **Instruction example 4.4. Vee-shaped attachment**

-  **Instruction example 4.5. Steel square**
Instruction example 4.6. Angle-steel frame table
 **Instruction example 4.7. Wall-shelf bracket**

Instruction example 4.6. Angle-steel frame table

To practise straight and mitre cuts on angles for angle splices to specified size.

Material

- **Angles of 25 x 25 x 5 thick, length depending on table size.**
- **Steel tube of 25 mm diameter, length depending on table size (or to suit training example 4.2.).**

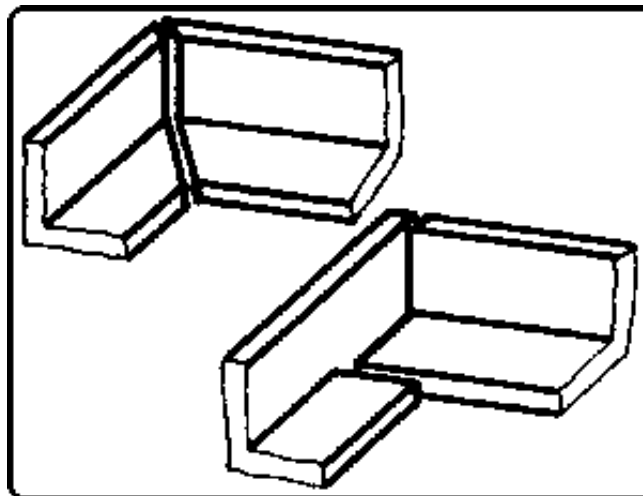

Figure

Hand tools

Steel scribe, mark-out punch, engineers' hammer, hand hacksaw (saw blade With normal tooth pitch), smooth-cut file 250 mm (flat).

Measuring and testing tools

Measuring tape, try square, protractor or centre square.

Accessories

Vice, whiting, cutting oil

Required previous knowledge

Reading of drawings, measuring and testing, scribing and prick-punching.

Sequence of operations	Comments
1. Arrange the working place, prepare the working materials.	- Check for completeness.
2. Saw 4 angles roughly to specified length (5 - 10 mm longer than specified).	- Length to be specified by the instructor.
3. Coat all end faces with whiting after drying scribe and prick-punch the 45° angle for the mitre cut, saw the mitre.	- Stage (1) Scribe on the outside face.
4. Scribe the exact length from the mitre side, mark and prick-punch the cutout (square)/straight cut at this end face.	- Stage (2) Mitre cut, cutout and straight cut to be specified as per drawing (straight cut to be scribed outside, cutout to be scribed inside)

5. Saw 4 steel tubes to specified length (depending on table height), constantly turn the tubes while sawing 1

- Stage (3)

6. Final inspection.

- Quality of mitre cut and straight cut.

Completion

Deburr the cut edges, put individual parts together and have them welded together. Insert a steel plate or wooden plate.

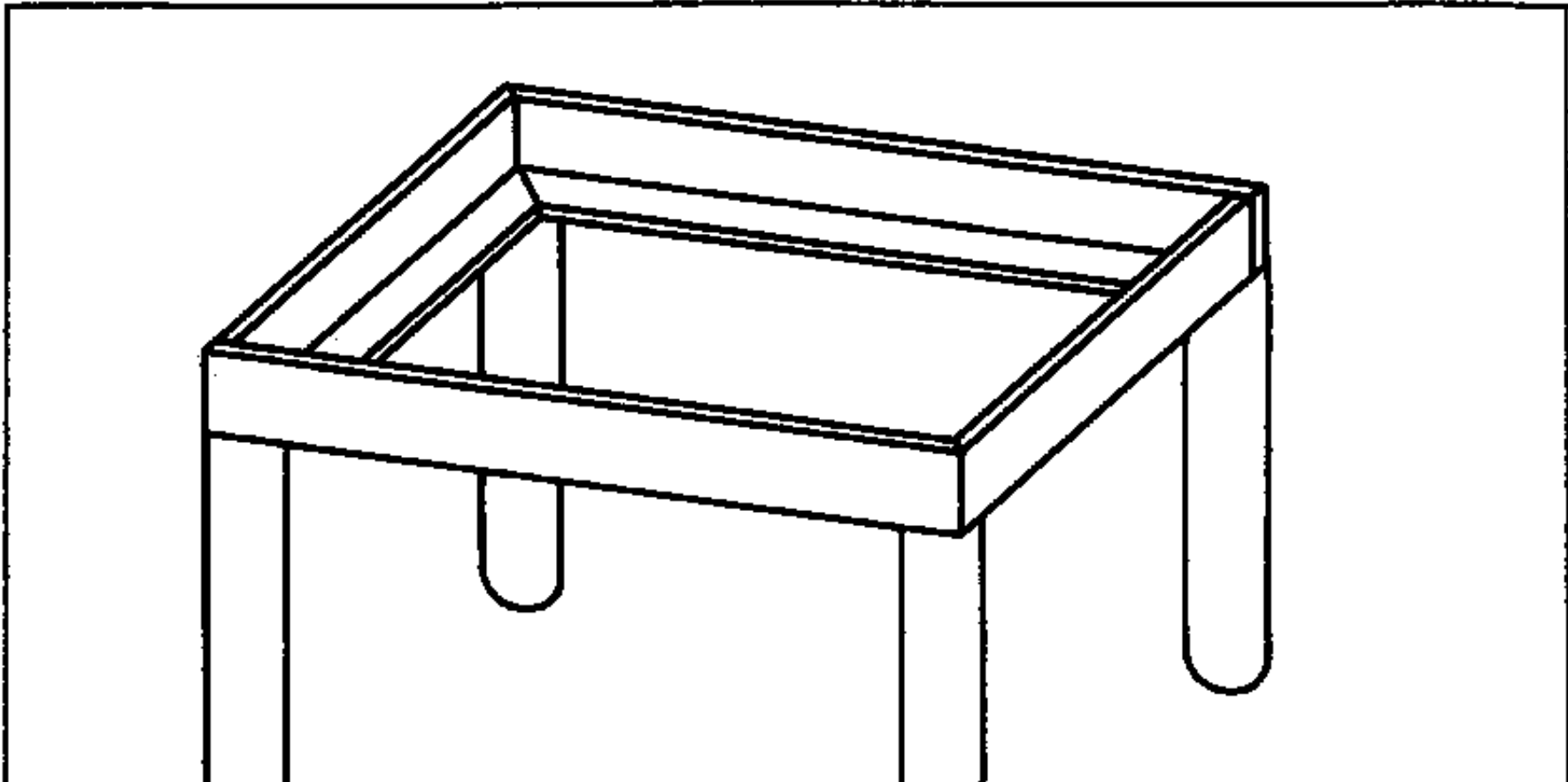

①

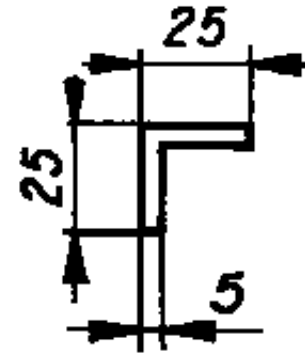
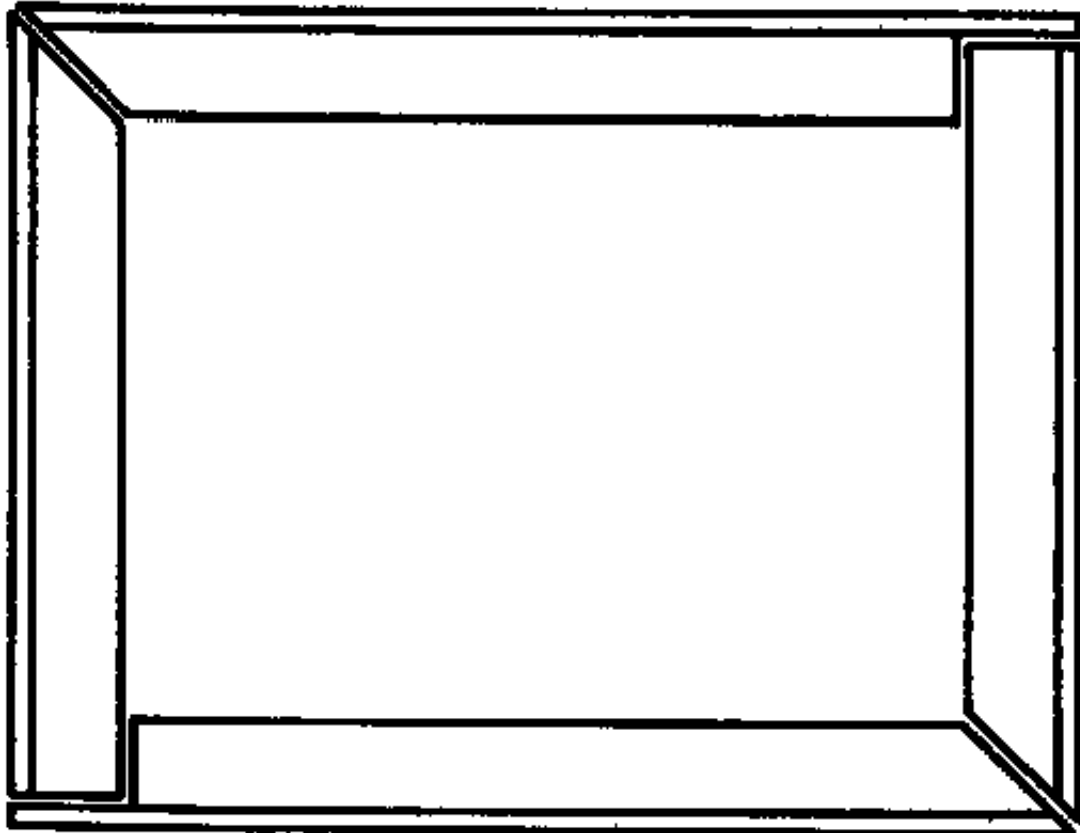

②

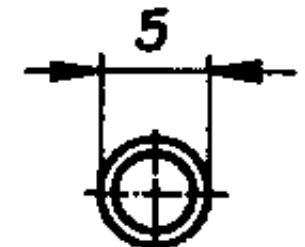

③

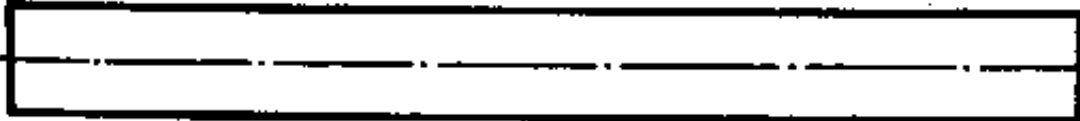

				4.6.
	Angle-steel frame table			3104

Angle-steel frame table



[Home](#) > [ar](#).[cn](#).[de](#).[en](#).[es](#).[fr](#).[id](#).[it](#).[ph](#).[po](#).[ru](#).[sw](#)

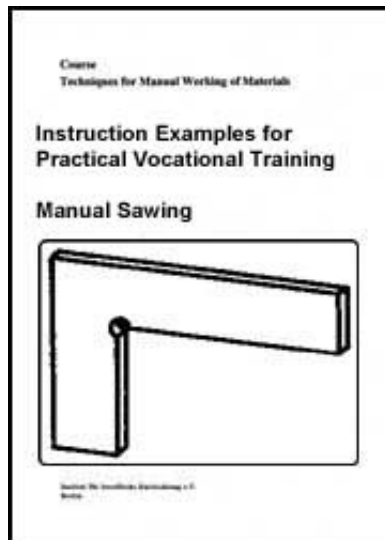

Manual Sawing - Course: Technique for manual working of materials. Instruction examples for practical vocational training (Institut fr Berufliche Entwicklung, 31 p.)

(introduction...)

Introduction

Instruction example 4.1. Spacers and pin drifts

Instruction example 4.2. Stands and supports

Instruction example 4.5. Container

Instruction example 4.4. Vee-shaped attachment

Instruction example 4.5. Steel square

Instruction example 4.6. Angle-steel frame table

Instruction example 4.7. Wall-shelf bracket

Instruction example 4.7. Wall-shelf bracket

To practise mitre cuts with increased level of difficulties and bevel cuts and cutouts on angles.

Material

- Unequal-leg angles of any steel 20 x 30 x 4 thick, approx. 1000 mm long.**
- Sheet steel
70 x 70 x 2.5 thick.**
- 4 button-head rivets
4 mm diameter
(of copper or aluminium).**

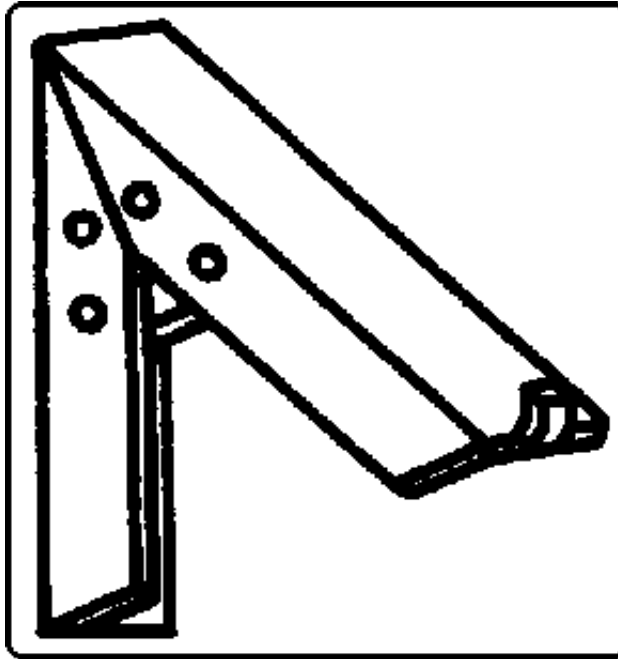

Figure

Hand tools

Steel scriber, mark-out punch, engineers' hammer, hand hacksaw (saw blade with normal tooth pitch), 4.1 mm dia. and 5.5 mm dia. drills, 75° countersink, smooth-cut file 250 mm (flat).

Measuring and testing tools

Steel measuring tool, try square.

Accessories

Vice, surface plate, levelling plate, rivet set for 4 mm dia. rivets, rivet header for 4

mm dia. rivets, pin vice.**Required previous knowledge****Reading of drawings, measuring and testing, scribing and punch-marking.**

Sequence of operations	Comments
1. Arrange the working place, prepare the working materials.	- Check for completeness.
2. Scribe the angles and saw to initial length. Saw out the pivot at one end face 6 x 10, remove burrs with the file.	- Determine length by width of shelf! - Note: left-hand and right-hand wall-shelf bracket.
3. Scribe centre and 90° mitre angle (inside), saw out the angle, remove burrs.	- Stage (1) Clamp angle so that sawing cut will be vertical!
4. Bend the angle in the vice by means of the engineers' hammer, bend the pivot (upward).	- Stage (2) Check for right-angularity by means of try square.
5. Saw out the steel sheet to specified size, remove burrs.	- Stage (3)
6. Inspection of cuts.	
<u>Completion</u> - Scribe holes on steel sheet, prick-punch and drill with 4.1 mm dia. drill.	- Drill under supervision of the instructor with steel sheet clamped in pin vice. Speed: approx. 1400 r.p.m.

- Insert the drilled sheet inside the bent angles and prick-punch the angles through the holes of the sheet, drill with 4.1 mm dia. drill.

- Use sheet as stencil!

- Scribe and prick-punch the 5.5 mm dia. holes, drill all scribed holes.

- Pay attention to specified sizes!

- Countersink 4.1 mm dia. holes from the outside of the angles with 75° countersink.

- Speed: approx. 350 r.p.m.
Countersink diameter: 7.0 mm

- Clamp angle and sheet together in pin vice, then rivet together

- Stage (4)

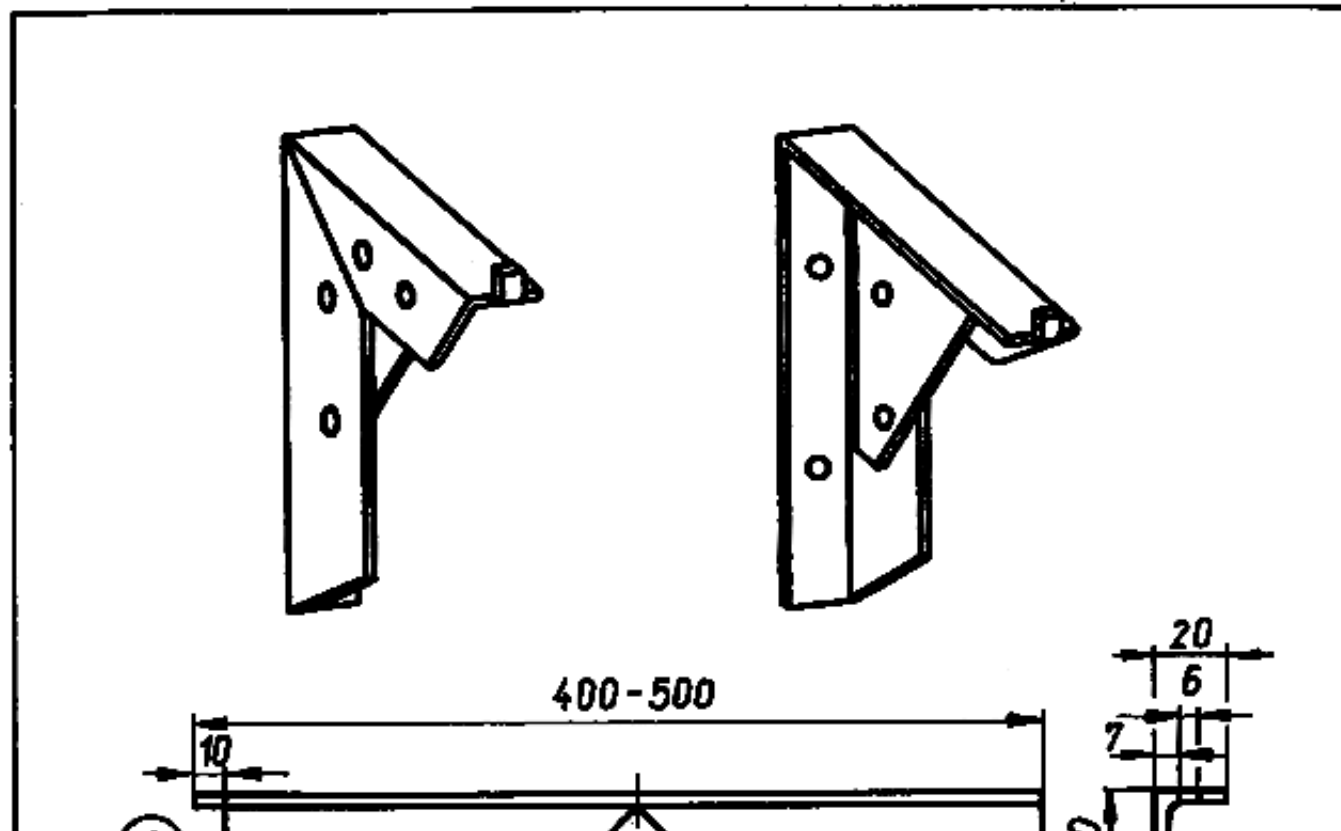

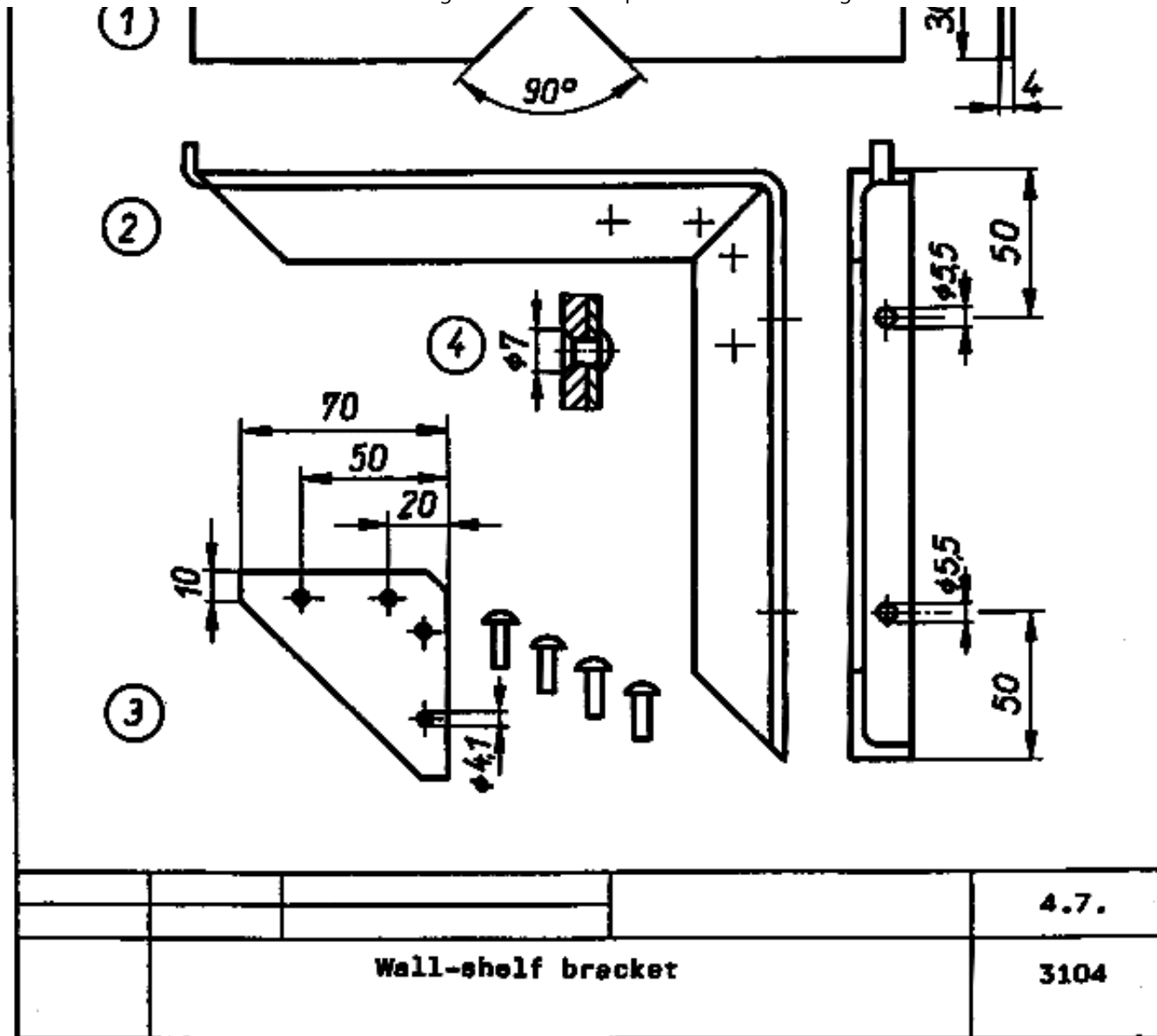

Wall-shelf bracket

