

## **Series of Transparencies – Basic Skills in Metal Working**



# Table of Contents

<b><u>Series of Transparencies – Basic Skills in Metal Working</u></b> .....	<b>1</b>
<u>1. Notes on the series “Basic skills in metal working”</u> .....	1
<u>2. List of projection films on “Basic skills in metal-working”</u> .....	2
<u>3. Notes on the transparencies</u> .....	3
<u>List of films</u> .....	13



# Series of Transparencies – Basic Skills in Metal Working

10.1

INSTITUT FÜR BERUFLICHE ENTWICKLUNG



This series of transparencies was elaborated by a team of authors under the auspices of the Zentralstelle für Bildungswesen des Schwermaschinen- und Anlagenbaues:

Dipl.–Päd. Günter Aisch  
Dipl.–Ing. Dieter Bonitz  
Dipl.–Lehrer Wolfgang Dost  
Dipl.–Lehrer Rainer Hofbauer  
Dipl.–Lehrer Bernd Müller  
Ing.–Päd. Gerhard Näther  
Dipl.–Ing.–Päd. Harry Richter, head of the team of authors

Graphic design:

Günter Brabant, film graphic artist  
Award winner in the GDR

Editorial revision:

Günter Zweynert Oberlehrer Dipl.–Ing. paed. Ing.

Published by:

Zentralstelle für Bildungswesen des Schwermaschinen- und Anlagenbaues  
–7010 Leipzig, Barfussgässchen 12

Orderer:

Institut für berufliche Entwicklung  
– 1080 Berlin, Französische Strasse 47

© ZSB Leipzig 1982

## 1. Notes on the series “Basic skills in metal working”

When training people for occupations in the metal-working industry, the acquisition of work experience, abilities and skills in manual and simple mechanical metal-working is of fundamental importance.

The work techniques

- scribing
- measuring and testing
- sawing
- shearing
- drilling and countersinking
- threading
- filing
- bending and straightening

are taught in complex assignments.

The series “Basic skills in metal–working” is suitable both for imparting knowledge and for developing the ability of trainees within the framework of polytechnical training and for consolidation and revision purposes further vocational training.

When designing the transparencies, great importance was attached to the use of coloured and perspective representations of the technical and technological relations and facts.

Despite the necessary simplification, scientifically based information is given.

For reasons of economy, the transparencies have been designed in A 4 format and are kept in a folder together with technical and methodical notes.

The transparency cases are ideal for keeping personal notes and additional self–made covering sheets which are used with the transparencies.

For proper placing of the transparencies on the overhead projectors in upright size or broadside format, a simple frame has been enclosed with the series. The three–point arrangement of the frame (narrow side to the left) allows proper fixing of the covering sheets in the supporting system.

The covering sheets can easily be adjusted to size and allow the teachers to provide additional information or to vary their presentation of information. The original transparencies are not damaged by this. To help make the plastic covering sheets true to size, markings have been provided on the edge of the sheets (short vertical or horizontal strokes).

In the technical notes, no information about health protection, industrial safety or fire prevention has been given. For information of this type, see the relevant regulations and specialized literature.

## **2. List of projection films on “Basic skills in metal–working”**

m no.	Film title
1	Tidiness at the workplace
2	Sawing by hand
3	Selection of saw blades
4	Power hacksaw
5	Sawing work
6	Shearing
7	Clearance of cutting edges in shearing
8	Shearing and punching
9	Holding and guidance of the scriber
10	Scribing

- 11 Punching
- 12 Twist drills
- 13 Drillings
- 14 Bench–type drilling machine
- 15 Countersinking
- 16 Internal threading
- 17 External threading
- 18 Calculation of length subject to bending
- 19 Bending in vice I
- 20 Bending in vice II
- 21 Straightening of workpieces
- 22 Measuring with a vernier caliper
- 23 Testing of components
- 24 Testing with form gauges
- 25 Design and use of files
- 26 Types of file
- 27 Filing I
- 28 Filing II

### **3. Notes on the transparencies**

Film no. 1

#### Tidiness at the workplace

An essential task of polytechnical training is educating the trainee to achieve order and discipline. The first transparencie of this series allows the teacher to inform the trainees from the first lesson on how to arrange their workplace most suitably thus contributing to tidiness at the workplace.

The arrangement and selection of tools and testing instruments depends to a large extent on the work to be done.

For this reason, the arrangement of the tools and testing instruments on the work table should be considered only as an example. The arrangement of tools in drawers depends on the number and type of the tools.

It is essential that the attention of the trainees be drawn to the importance of properly placing and preparing tools and testing instruments for high–quality work.

Film no. 2

#### Sawing by hand

The transparency shows the initial sawing of a flat steel with a hand hacksaw and, in a magnified section two saw teeth cutting into the steel.

In this way basic knowledge from the manual training, such as the design of the hand hacksaw, can be revised and consolidated. Using this transparency, the following crucial points can be dealt with:

- Clamping of a workpiece (maximum dimension is in the direction of cutting, rigid clamping)
- Clamping of the saw blade (the teeth point in the direction of cutting – red arrow –)
- Initial sawing under a small lead angle
- Geometry of the cutting edge.

It is advisable to mark the individual angles at the saw tooth with different colours and to explain these using a self-made covering sheet.

Film no. 3

### Selection of saw blades

The selection of saw blades is mainly governed by the tasks to be fulfilled.

The transparency is intended to help the trainee to recognize the saw blades by their pitch (spacing between crests) and to select them according to the material to be worked and in accordance with its properties.

In three magnified sections, a coarse, a medium and a fine pitch can be distinguished. The teacher should take this opportunity of explaining how the selection of saw blades should be made according to the material to be worked:

Section 1: fine saw pitch for

- thin-walled workpieces such as pipes, sections, etc.
- hard materials such as alloyed steels and cold formed materials such as wires, sheets and plates, etc.

Section 2: coarse saw pitch for

- soft materials where a large number of cuts can be expected, such as aluminium
- plastic materials such as thermoplastic material, etc.

Section 3: medium saw pitch for general workshop use.

Film no. 4

### Power hacksaw

In this transparency, the power hacksaw is shown as a diagrammatic sketch. In a magnified section the operating principle of the sawing process is illustrated. The following can be acquired by the trainee:

- Design and operating principle of a power hacksaw (crank drive)
- Clamping of the workpiece
- Drawing mode of operation
- Load of the saw frame and
- Altering the cutting pressure by shifting the weight on the saw frame.

Film no. 5

### Sawing work

Two examples of special sawing work are given. In example 1 the trainees are informed about the sawing of deep cuts with the saw blade turned by 90°, Example 2 shows the sawing of pipes in prismatic clamping jaws.



The hand hacksaw is not shown. It should be pointed out that when sawing pipes the pipe must be turned several times in order to avoid tooth breakage and uneven cutting. In both examples, the function of the clamping jaws which are used must be dealt with.

Film no. 6

### Shearing

Sheets and plates as well as flat and sectional bars can be cut by shearing, while scribing can be adhered to precisely. This requires knowledge of the shearing process. The relevant transparency shows the operating principle of shearing in a simplified way.

The two shear blades with the conical cutting edges and the holding down clamp with the workpiece can be seen.

The acting forces are marked by red arrows. A distinction must be made between the absorption of force by the holding down clamp and the continuously acting cutting forces of the shear blades.

The workpiece is shown in the phase of bending and initial separation (slide planes form in the material).

In a magnified section of the area of cut, the trainees can see: plate is pushed forward and is difficult to guide.

Note that the plate thickness in Figure 1 is magnified. In general, hand plate shears are only used for cutting thin sheets (e.g. steel sheet up to about 1 mm thick, aluminium sheet up to about 2 mm thick).

Figure 2 shows the punch (dark blue), the die plate (green) and the sheet strip (workpiece/lighter blue). In the die plate only the path of the punched material is indicated. The outline of the opening in the die plate has been omitted. The opening in the die plate (lower die) can be illustrated in a self-made covering sheet.

The following form of representation is recommended (cf. transparency no. 7)

s = blade clearance  
? = clearance angle

Film no. 9

### Holding and guidance of the scriber

Transferring the shape and size of the workpiece according to workshop drawings to the starting material requires great care. The scribed lines must be clearly visible and must also remain visible during working. For this reason, scribing is often carried out with a scriber. Using transparency no. 9, holding and guidance of the scriber can be explained to the trainees. The accuracy of the size of the workpiece is determined mainly by the quality of scribing.

Instruction in careful, scrupulous work and care of the scribing tools is the essence of this transparency.

Film no. 10

### Scribing

Before scribing bores, one or two reference edges are required. The reference edges of the workpiece (underlined in red) can be derived from the simplified technical drawing (dimensioning from 2 reference edges).

The fitting of the try square to the prepared reference edges is shown. The teacher should demonstrate how the dimensions must be plotted from the right-hand reference edge using the steel measuring tape.

Scribing is done using the scribing point. This scratches the surface of the workpiece. A considerable notch effect is caused by the sharp base of the scribed line, causing concentrations of stress which have several times the value of normal stresses. Therefore this danger must be indicated during lessons. With soft materials or materials where the surface must not be damaged (because of the corrosion hazard), scribing

points of brass or lead pencils should be used.

The transparency does not show whether or not the surface of the workpiece has been prepared for scribing. Whitening with whiting, coppering with copper sulphate or varnishing with scribing varnishes make the scribed lines easier to distinguish. Using a concrete example from the works production, it should be shown that the shape to be scribed and the quantity play an essential part in the selection of the scribing process.

Film no. 11

### Punching

Punching is the technique immediately subsequent to scribing. The punch provides a scribed line with controlling punch marks in order to control the scribed lines, which become less visible as work proceeds. Half of the control punch marks must be left on the work edge. Furthermore, centres of bores are fixed by punching. In practice, a distinction is made between marking-out punches (point angle  $30 - 40^\circ$ ) and centre punches (point angle  $60^\circ$ ) (see transparency).

Punching requires a lot of skill.

The punch must be inclined so that the position of the centre can be observed.

When the centre corresponds with the scribed centre, the punch must be held vertically; the side of the hand must rest on the workpiece. The punch must then be driven into the workpiece by a short vertical blow with a locksmith's hammer up to a weight of 250 g.

Film no. 12

### Twist drills

The punched bore (see transparency no. 11) is drilled by means of a drilling tool and a drilling machine.

As a rule, standardized twist drills are used in practice. Twist drills above 10 mm in diameter are generally made with a taper shank (machine taper) and below 10 mm diameter with a cylindrical shank.

The transparency can be used both for showing the parts of the drill, the tool geometry and the parts of the drill point, and for revision, exercise purpose and checking progress. The following can be seen on the two drills (top to bottom):

Left drill: diameter  $> 10$  mm

tang, taper shank of tool, mark recess (neck), body with principal cutting edge, flute and secondary cutting edges (margins)

Right drill: diameter  $< 10$  mm

cylindrical shank, body with principal and secondary cutting edges and flute.

Figure 1 shows the angles at the cutting edge of the drill. The angle of lip clearance  $\alpha$ , lip angle  $\beta$  and cutting rake  $\gamma$  must be explained. The relation of the cutting rake to the flute helix angle in connection with the material to be worked must be mentioned.

In Figure 2 the designations at the drill point, such as the principal cutting edge, helical flute, chisel edge angle of point, flank, web thickness (secondary cutting edge, margin not drawn) and the flank of the secondary cutting edge can be discussed.

In Figure 3 the point angle, which is formed by the two principal cutting edges, is marked. This largely depends on the material to be worked. For aluminium it is  $130 - 140^\circ$ , and for steel approx.  $118^\circ$ .

The point angle affects the service life of the drill's cutting edges. The two principal cutting edges must be of equal length in order to avoid drilling faults.

Explain to the trainees that labour productivity is increased by continuously improved drill points using commercial spiral drills. (e.g. centring grind drill).

Film no. 13

### Drillings

Using this transparency, the purpose, use and special features of drilling can be dealt with and effective operating processes such as drilling with drill jigs can be explained.

Figure 1 shows that it is advisable to pre-drill large holes.

The pre-drilled hole serves as a guide and also relieves pressure from the chisel edge of the larger drill. Moreover, it helps prevent the drill from going off-centre.

The illustrated hole is a through hole.

Figure 2 shows a through hole.

Figure 3 shows a blind hole. The trainees should be instructed that, when determining the depth of the hole, one should not start at the drill hole point but at the cylindrical part of the hole.

Figures 4 and 5 show that a base is required for making a through hole so that the drill table is not damaged.

Film no. 14

### Bench-type drilling machine

The transparency shows the design and operating principle of a commercial bench-type drilling machine in section. The trainees should be familiarized with the design and operating principle of the machine step by step. The coloured representation of the most important assemblies is of great assistance and allows trainees to draw conclusions regarding the modular unit principle of machine tools.

It is advisable to trace the direction of force lines from the driving motor via the belt drive to the drill spindle and the tool.

The trainees should make use of their prior knowledge. The most important assemblies shown are:

- electric motor as drive
- cone pulley drive  
(other types are equipped with gear drives)
- drilling spindle with feeding mechanism and chuck
- drill table for holding workpieces
- column to support the assemblies.

Film no. 15

### Countersinking

With this transparency the trainees are given a survey of the most important countersinks and can classify countersinking into the systematics of manufacturing processes. Countersinking is a technique in which pre-drilled or cored holes are bored and their faces worked.

This is illustrated by four examples.

Figure 1 Counterbore and counterboring tool with pilot

The counterbore is used for countersinking cylindrical recesses (bolt head reception). The fixed or exchangeable pilot pin guides the counterboring tool with pilot.

#### Figure 2 Tapered countersink (countersinking cutter)

Tapered countersinks are used for taper countersinking and for deburring. The angles of taper correspond to the standardized countersunk angles of bolts and rivets and are of  $60^\circ$  or  $120^\circ$ . The spacing of the cutting edges is non-uniform in order to avoid the cutting edges from digging in.

#### Figure 3 Counterbore with spiral flutes

Counterbores with spiral flutes are used for boring cored holes. It is clear from the picture that counter-bores with spiral flutes are provided with several principal cutting edges, in most cases 3, more seldom; this allows smooth running.

#### Figure 4 Centre drill

The centre drill is a combination of a single-edged drill and a centre reamer or form countersink and is used for centring workpieces as a preparation for turning. The cutting edge angles of the countersinks have been indicated and should be supplemented by the standardized numerical values.

The trainees should be made aware that in countersinking too there is a rotating primary motion and a straight-line feeding motion.

Film no. 16

#### Internal threading

This transparency shows the preparation of a bore with internal thread in four steps.

##### Step 1 Preparation of a core hole

The core hole is prepared with the spiral drill using a table drilling machine. The diameters of the core hole bores are standardized. If the core hole is excessively large, the thread is not sufficiently cut (Refer to the use of chart books or standards, the selection of the correct diameter of spiral drill and checking by means of a vernier caliper).

##### Step 2 Spot-facing of the bore

The core hole bore should be spot-faced up to the nominal thread diameter by a  $60^\circ$  conical countersink.

##### Step 3 Entering tapping of the internal thread

The entering tap must be applied at right angles to the workpiece surface on all sides and turned into the core hole bore with low feeding power.

The marked start of cut should be observed when determining the depth of the core hole in a blind hole bore.

##### Step 4 Plug tapping of the internal threading

The plug tap is initially turned in by one hand. Once insertion into the entering tapplings of the thread is secured, the tap wrench can be put on and the thread can be plug tapped.

In magnified sections the quantity of chips is shown which is obtained in internal threading.

The trainees should be instructed that the chips are to be loosened and broken by alternately turning forward and backward. The trainees must recognize by means of practical examples how important standardization is for the national economy.

Film no. 17

### External threading

A simple cutting die is shown on the transparency. This cuts an external thread on a bolt.

The design of the cutting die should be explained:

- Cutting die holder (shown in green) with outlined threaded pins (holding screw, 2 thrust bolts and 2 spreading screws).
- Cutting die with 4 cutting edges: spot-faced at 60° on both sides. The start of the cut has a length of 1.25 to 1.5 times the pitch. Cutting dies are made of tool steel (shown in bluish-grey).

As compared with internal threading, external threading has the following special features:

- Before using the cutting tool, the bolt head must be chamfered and, if necessary, filed so that it is crowned (top left).
- The thread is cut by the cutting die in one operation without interruption (cooling, lubrication, chip breaking and chip removal are necessary)
- After starting the cut, no more pressure should be exerted.

Film no. 18

### Calculation of length subject to bending

Bending is the plastic change in the shape of a solid body and is used in a number of ways in the metal-working industry. When forming a material, its volume remains constant. During bending, the material layers are stretched and upset. Since only the so-called neutral fibre retains its original length, it is used for calculating the length subject to bending.

A bent workpiece is shown on the transparency in a very simplified way. The neutral fibre has been drawn in black. As a rule, it passes through the centre of gravity of the material cross-section (with symmetrical cross-sections it passes through the centre).

In order to illustrate stretching and upsetting to the trainees, a covering sheet can be placed within the range of length,  $l_3$  to illustrate this in a grid structure.

In the case of a very small bending radius ( $r < 5s$ ) the bending radius is shifted towards the pressure side.

The formula for calculating the length subject to bending shown on the transparency only applies if the bending radius is  $r \geq 5s$ .

Using this transparency, a simple length subject to bending can be calculated.

This transparency is suitable for checking progress, etc.

For this purpose, the formula should be covered over.

Note that an example with a bending radius  $< 5s$  has had to be chosen because of the design of the transparency.

Film no. 19

### Bending in vice I

Sheets, strip and flat steels of small dimensions are angled or bent in a vice.

The transparency shows the angling of workpieces in the vice with two examples:

Figure 1 Sheets of low strength and parts with a free bending leg are bent with a wooden hammer. The blows should be applied near the bending edge. Shims with formed edges (not shown) give the desired form to the bending point. Shims of wood or other soft material prevent damage to the workpiece surface. Plastic yielding results in internal stresses which favour the formation of cracks.

Figure 2 When bending short free legs a block of hard wood or another softer material should be used together with a locksmith's hammer.

Direct blows with a locksmith's hammer would result in buckling of the workpiece edges and workhardening of the material.

Film no. 20

### Bending in vice II

This transparency shows the rounding off of a workpiece in the vice in two figures.

Figure 1 Preliminary bending of a flat steel or sheet

The figure shows the phase of preliminary bending over a mandrel (round steel or pipe). Ensure that the workpiece is firmly clamped.

Figure 2 Finish bending

The finish bending of the pre-bent workpiece also proceeds in a vice.

Observe its resilience.

When bending soft materials use shims to prevent surface damage caused by the vice-jaws (shown in brown).

Film no. 21

### Straightening of workpieces

Workpieces must be straightened in the case of

- distortion of the components after heat treatment in the production process
- distortion caused by transport or storage.

Its purpose is to restore the original shape, and it is essentially based on a displacement of material. Straightening requires great technical skill and theoretical knowledge about the structural constitution and stress distribution. Using Figures 1–3 essential basic knowledge can be gained using three examples.

Figure 1 Deformations in the centre of the sheet are eliminated by stretching by applying light, uniform circular, hammer blows, striking more densely towards the edge. For small sheet

thicknesses and sensitive materials a wooden or rubber hammer should be used.

Figure 2 Edge stresses are eliminated in a similar way.

Figure 3 The buckled angle steel is aligned by stretching of the upset side.

Note: This method (one-sided stretching) can also be used to round off an angle steel.

Finally, bending and straightening should be compared with other production methods from the point of view of material economy.

Film no. 22

#### Measuring with a vernier caliper

The design and handling of the vernier caliper can be demonstrated efficiently with functionable models and the vernier caliper itself. This transparency is suitable for revision purposes and for learning the three basic possibilities of measuring with vernier calipers.

1 Measuring of external dimensions between the fixed and the movable leg

2 Measuring of internal dimensions by cross jaws – the measuring blades for internal measurement are aligned with the measuring faces for external measurement.

3 The depths of blind holes and grooves are measured by the depth micrometer (not shown in green).

In the magnified section, a part of the sliding member with the vernier and the beam millimeter divisions can be seen. The last scale division has not been drawn accurately; it must coincide with the scale division for 34 mm on the beam.

Film no. 23

#### Testing of components

The verbal statements in German must be translated for the trainees:

Testing                                      Measuring

Dimensional testing:                      Gauging:

Non-dimensional testing:    Comparing with specimens:

The transparency shows the testing of components using selected examples.

In the lessons, the teacher should supplement the symbolic representation using actual examples from practice.

In the Section "Measuring" reference should be made to comparing the physical quantity to be measured such as length, temperature, work, etc. (measuring quantity) of the workpiece, components or machine with a known quantity of the same type such as unit lengths, scale divisions, etc.

The purpose of measuring is the numerical determination of a measuring value (measuring value = numerical value × unit of measurement).

The Section "Gauging" should illustrate that a component must be checked for observance of the actual dimension within a tolerance range (limit gauges) or that the form of a component approaches a specified form (form gauges).

Non-dimensional testing deals mainly with the comparison of specimens, such as comparing the sound of grinding wheels after slight bouncing (clear sound indicates proper condition), etc.

Film no. 24

### Testing with form gauges

This transparency shows how to check the planeness of one or several faces and the angularity of a component.

Figure 1

Checking the angularity of a component with a thin steel try square.

The thin steel try square is shown here checking an angle of  $90^\circ$  on a component.

If there is angularity no gap is present when the thin steel try square is set on the surfaces to be checked (red).

(Mention the bevelled edge steel square).

Figure 2

Checking the planeness of the two bearing surfaces (red) of the component.

The hairline gauge has wedge-shaped ground measuring faces. The measuring edge is slightly rounded off. It is a high-quality testing tool and must be handled and used with care.

Typical testing patterns are found in testing. The handling of the hairline gauge when checking planeness must be explained (light gap method).

Film no. 25

### Design and use of files

The transparency shows a double-cut flat file on a workpiece which is clamped in a vice.

The basic design of a file and its usage can be explained by means of this transparency:

- The shank of the file with the two cuts and the tang with the handle can be seen; conclusions can be drawn about the cross-section
- The magnified section shows the contour of the file teeth and the chip space during one stroke of the file. Owing to the angular ratios given the file can be assumed to be one used for steel working. Using a self-made covering sheet the geometry of the cutting edge can be shown, if required. But it is in any case clear that scraping is required-, (negative rake angle).

The contact of the file on the workpiece shown and the distinguishable grooves in the workpiece should prompt discussion on the correct filing direction with reference to the workpiece edge and the quality required (see transparency no. 27) Explain to the trainees that manual filing for repairs and assembly work is at present often more economical than the use of the corresponding machines.

Film no. 26

### Types of files

The correct selection of files is important for high-quality filing.

Three characteristic types of file are shown:



- |                    |  |
|--------------------|--|
| 1 Single-cut files | for soft metallic materials milled teeth |
| 2 Double-cut files | for hard metallic materials cut teeth    |
| 3 Rasps (rasp cut) | for soft materials such as wood, etc.    |

The file teeth are clearly recognizable in magnified sections.

Film no. 27

### Filing I

The teacher can explain the mode of operation when filing using four figures:

Figure 1 Rough filing is done if more than 0.5 mm material is to be removed

Figure 2 Cross stroke filing is required when a high degree of planeness is required.

Figure 3 Smoothing is done with longitudinal strokes

Figure 4 Filing of 2 work faces in one plane

Film no. 28

### Filing II

Rough filing is compared with smoothing.

Figure 1 As a rule, only the motion of the arm should be used for filing.

When rough filing, the right hand has a guiding and feeding function while the left hand exerts pressure.

Figure 2 When smoothing and when using moderate sizes of file the left hand must assume the guiding function while the right hand is responsible for feeding.

## **List of films**

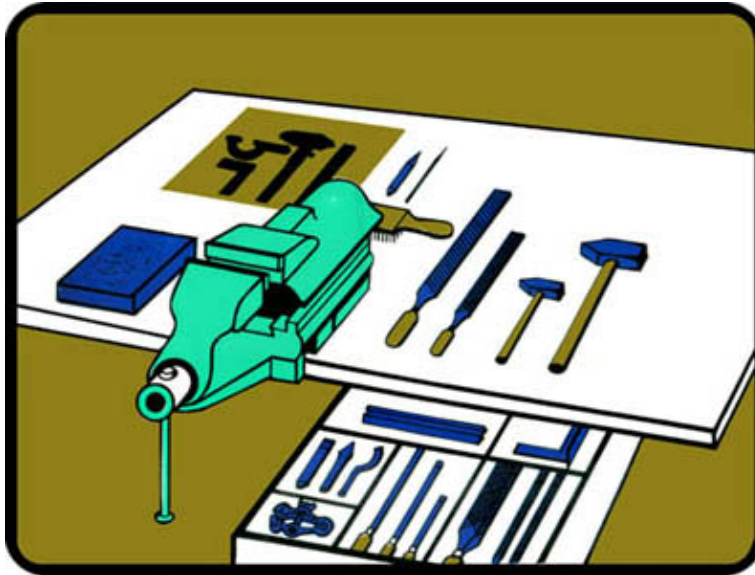

Film no. 1

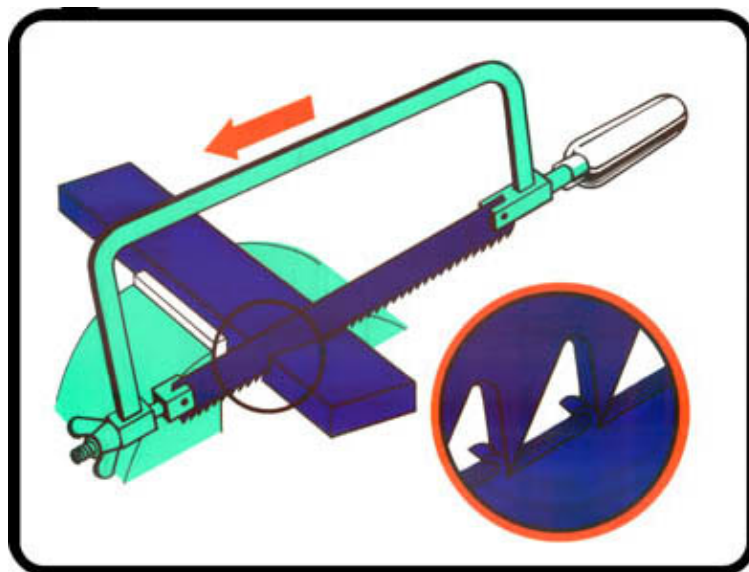

Film no. 2

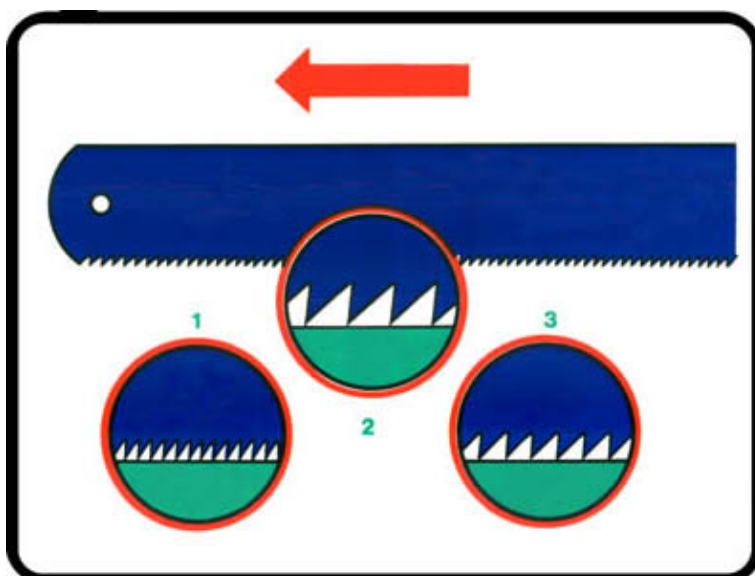

Film no. 3

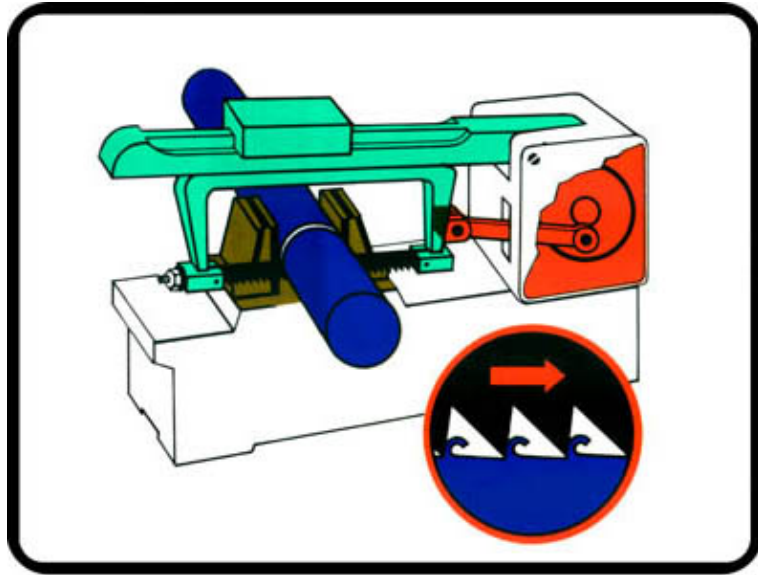

Film no. 4

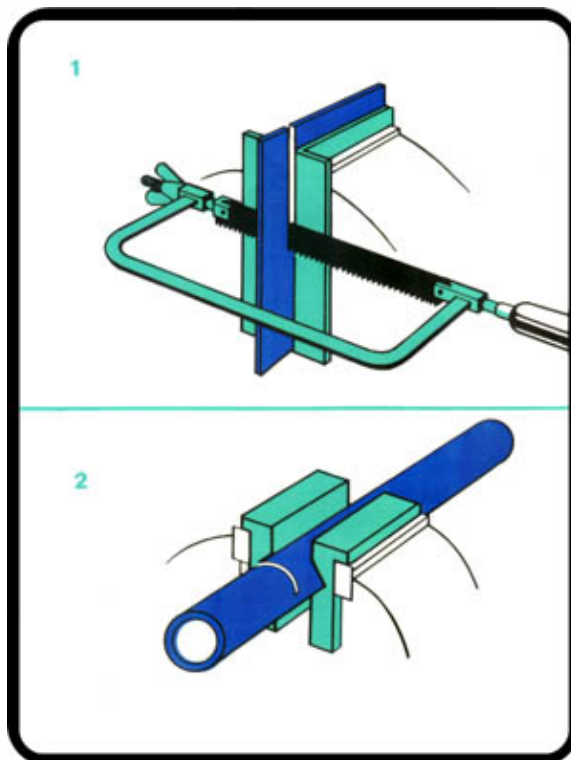

Film no. 5

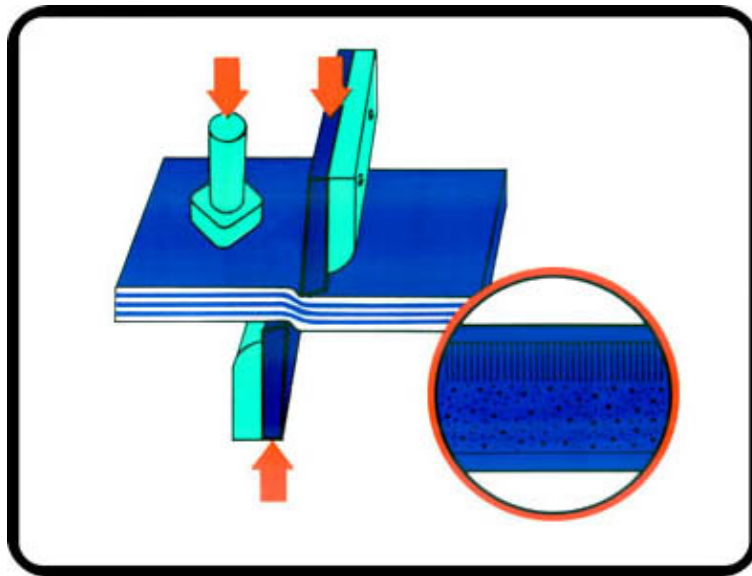

Film no. 6

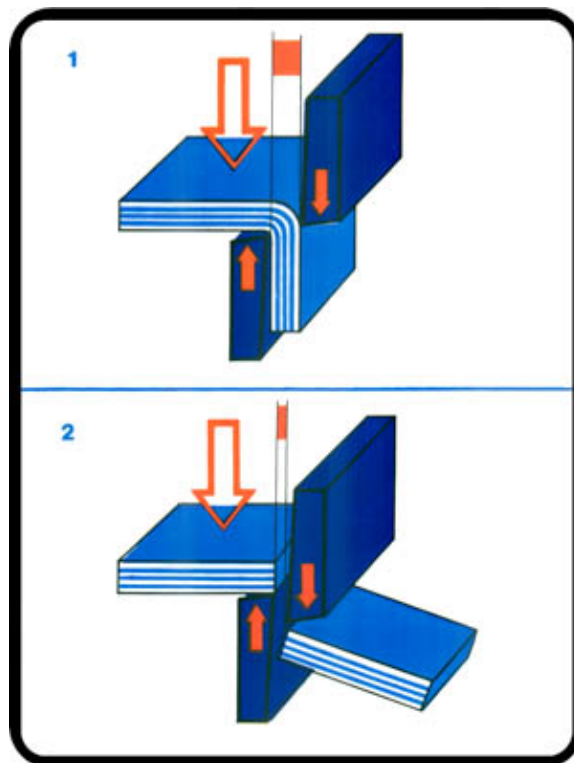

Film no. 7

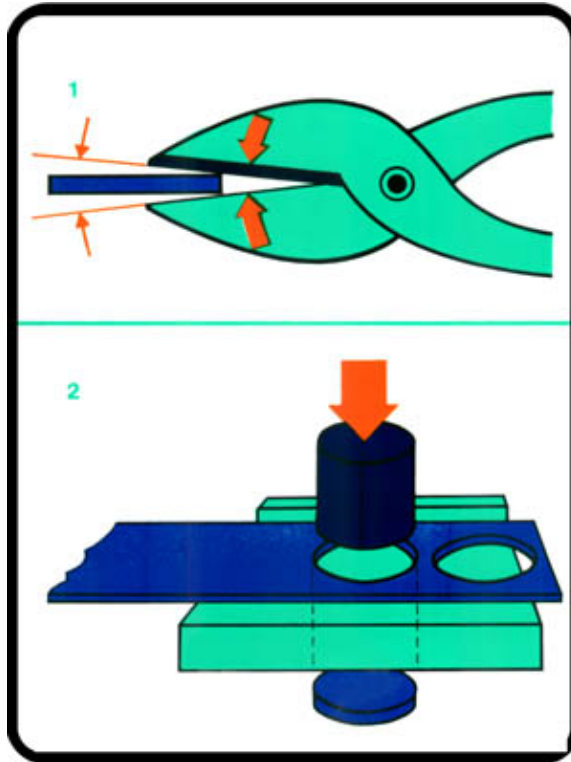

Film no. 8

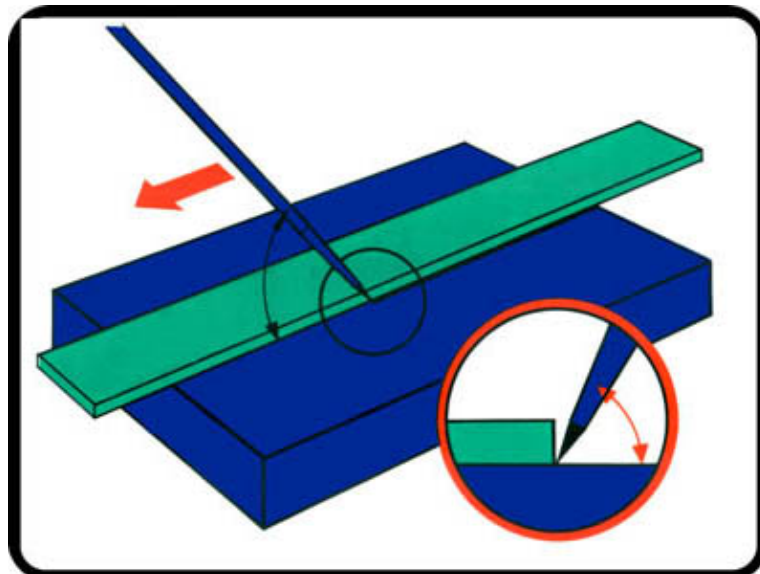

Film no. 9

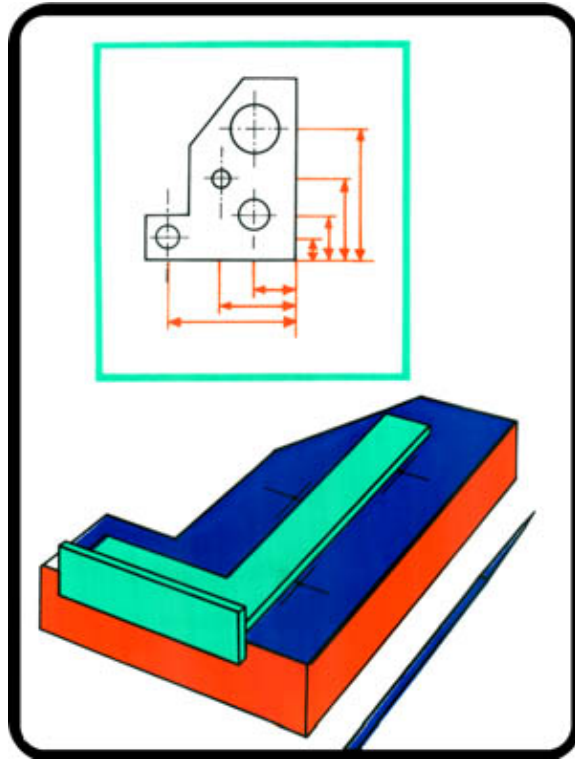

Film no. 10

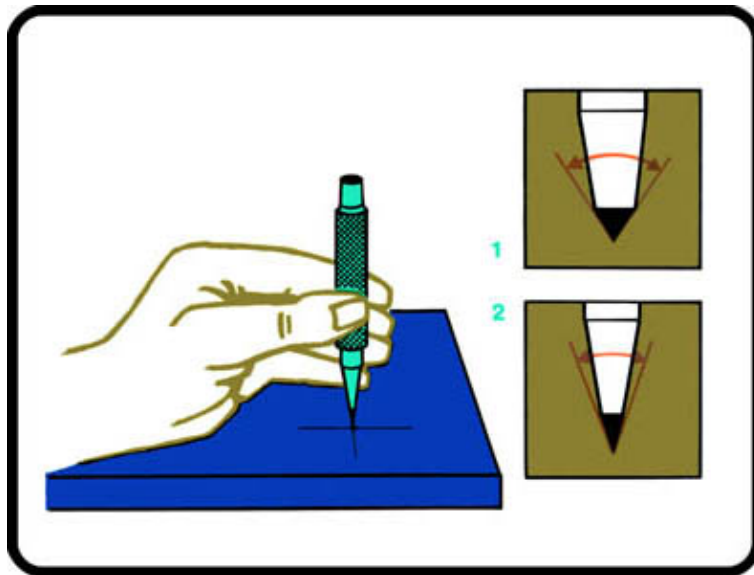

Film no. 11

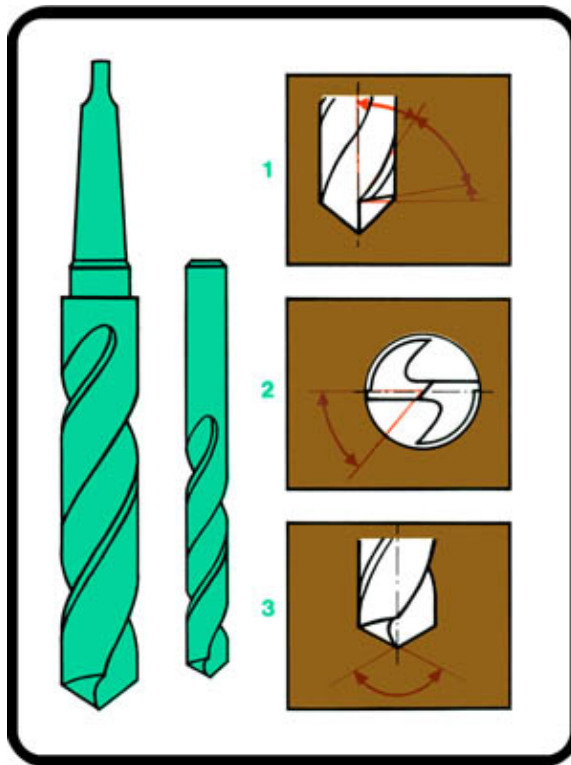

Film no. 12

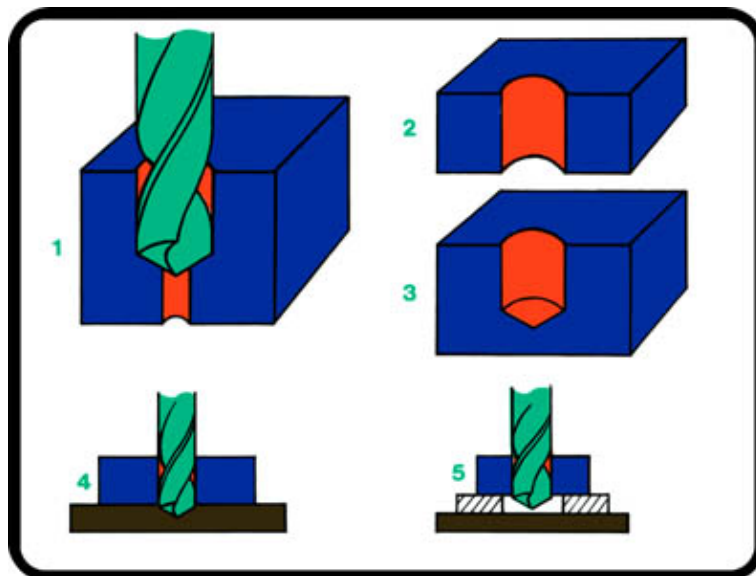

Film no. 13

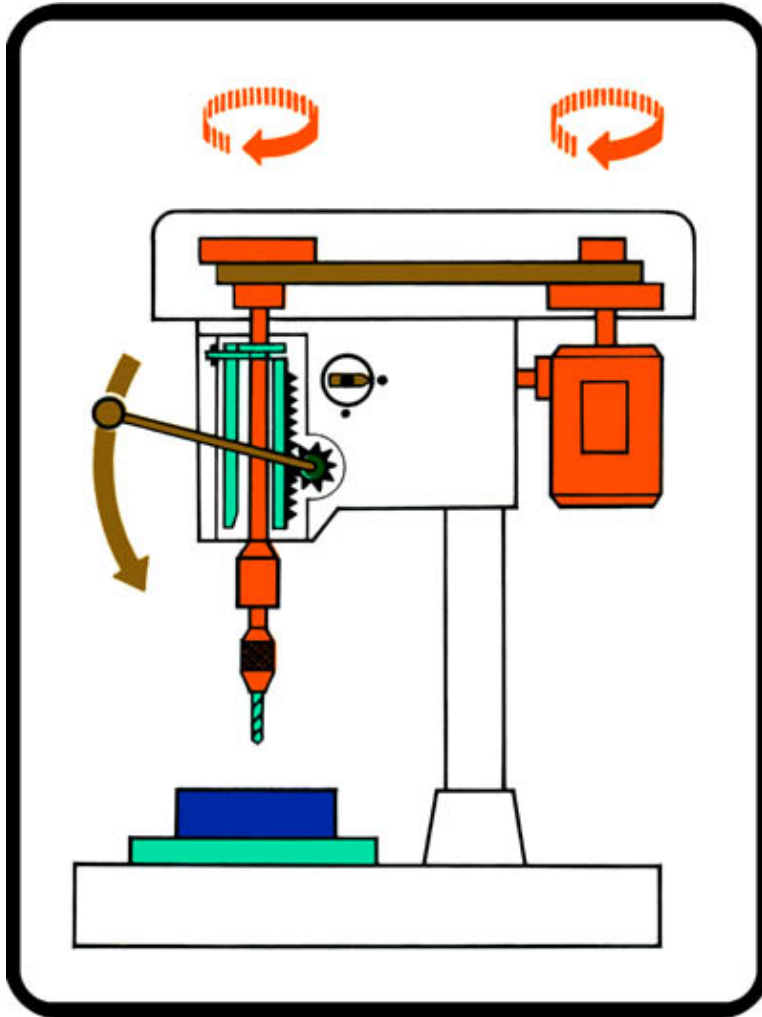

Film no. 14

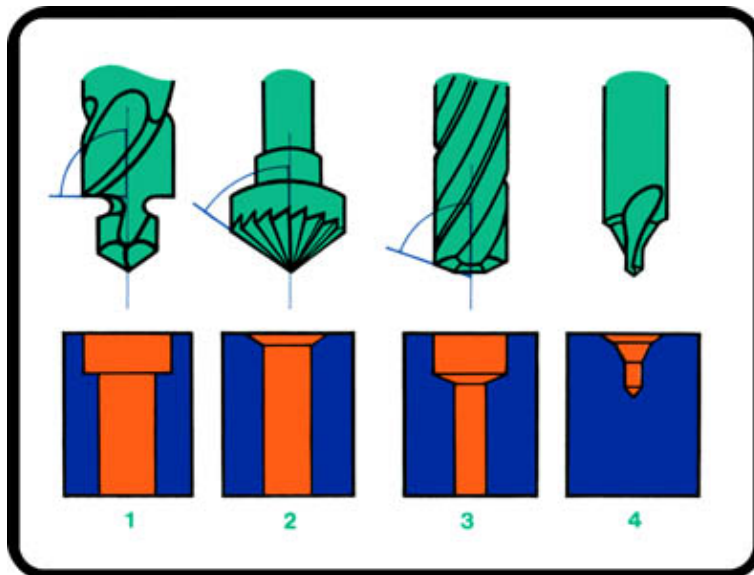

Film no. 15



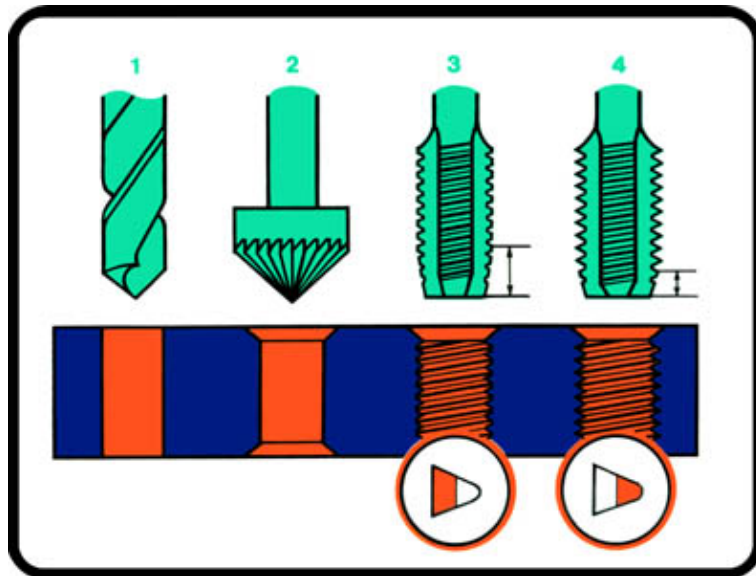

Film no. 16

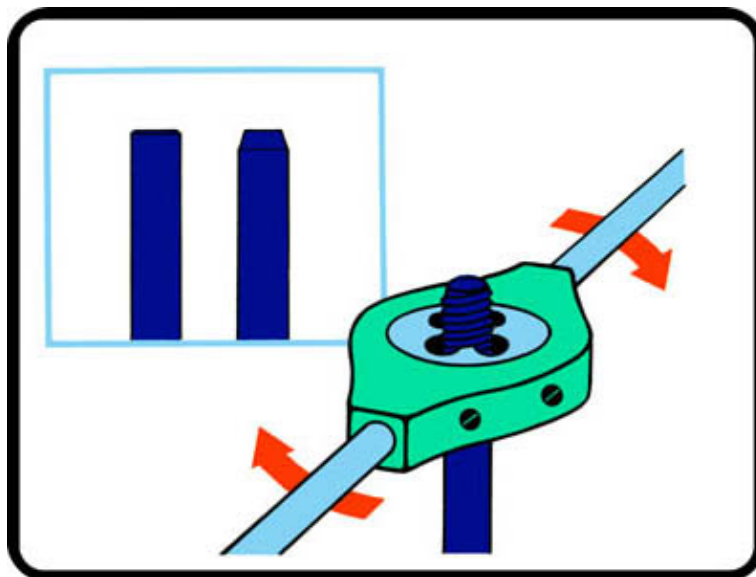

Film no. 17

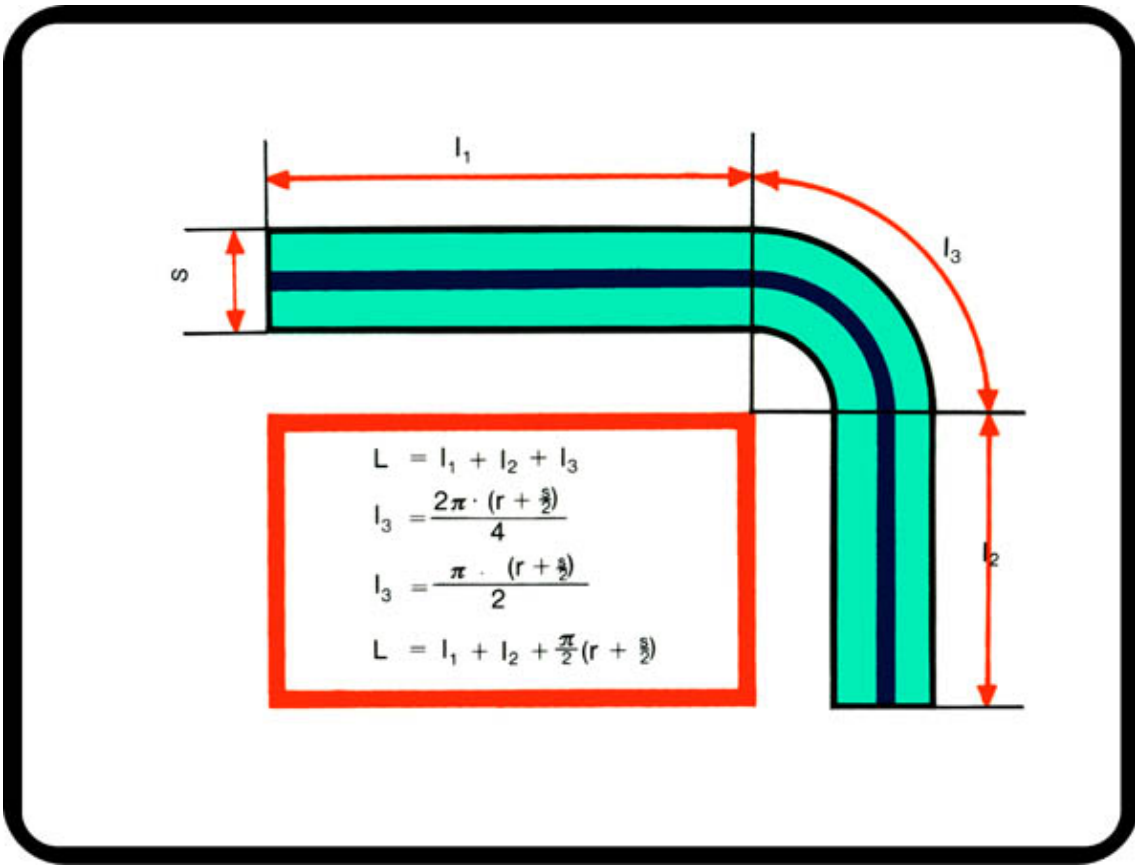

Film no. 18

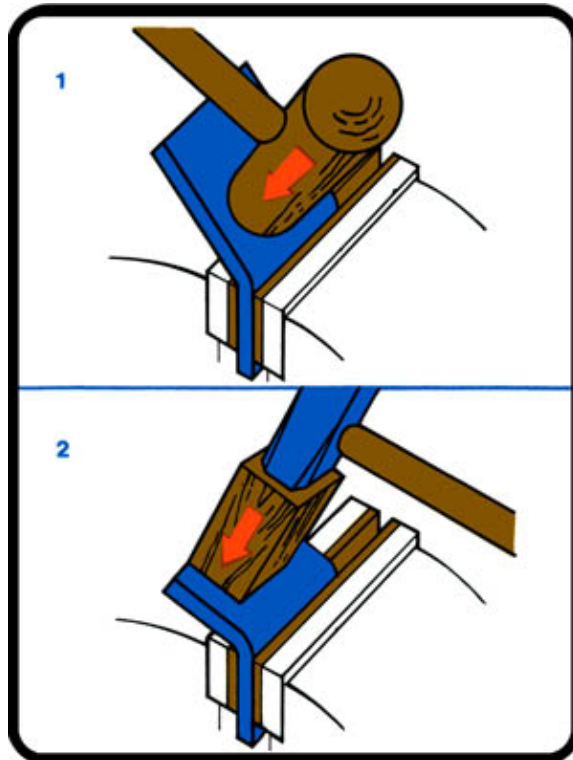

Film no. 19

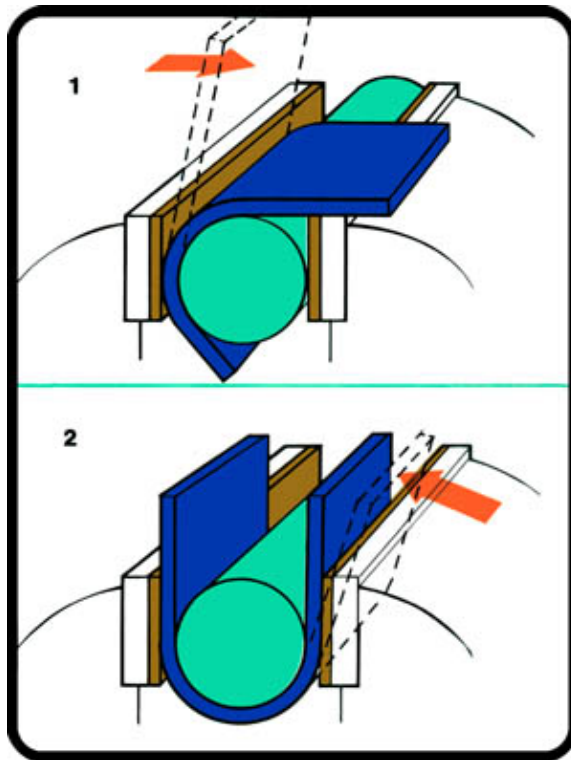

Film no. 20

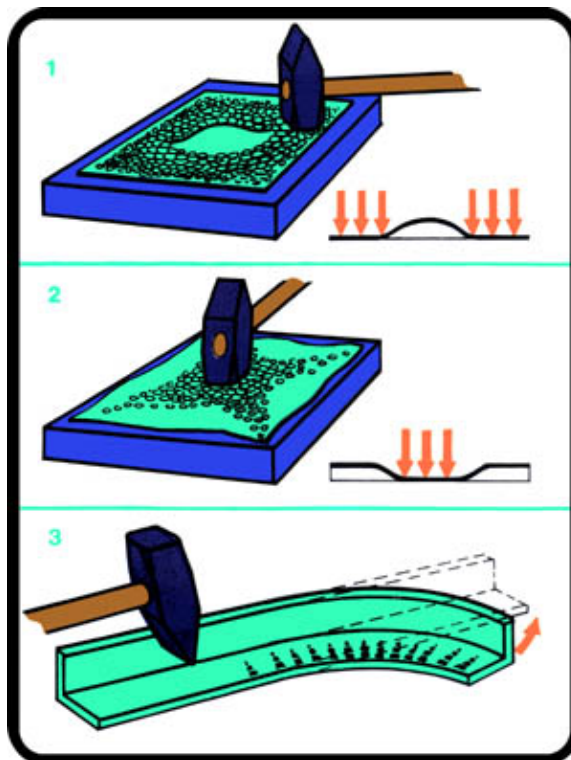

Film no. 21

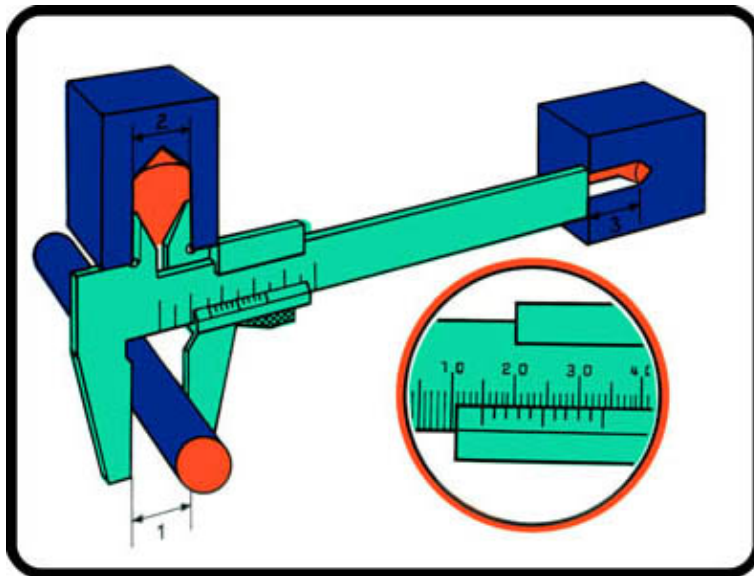

Film no. 22

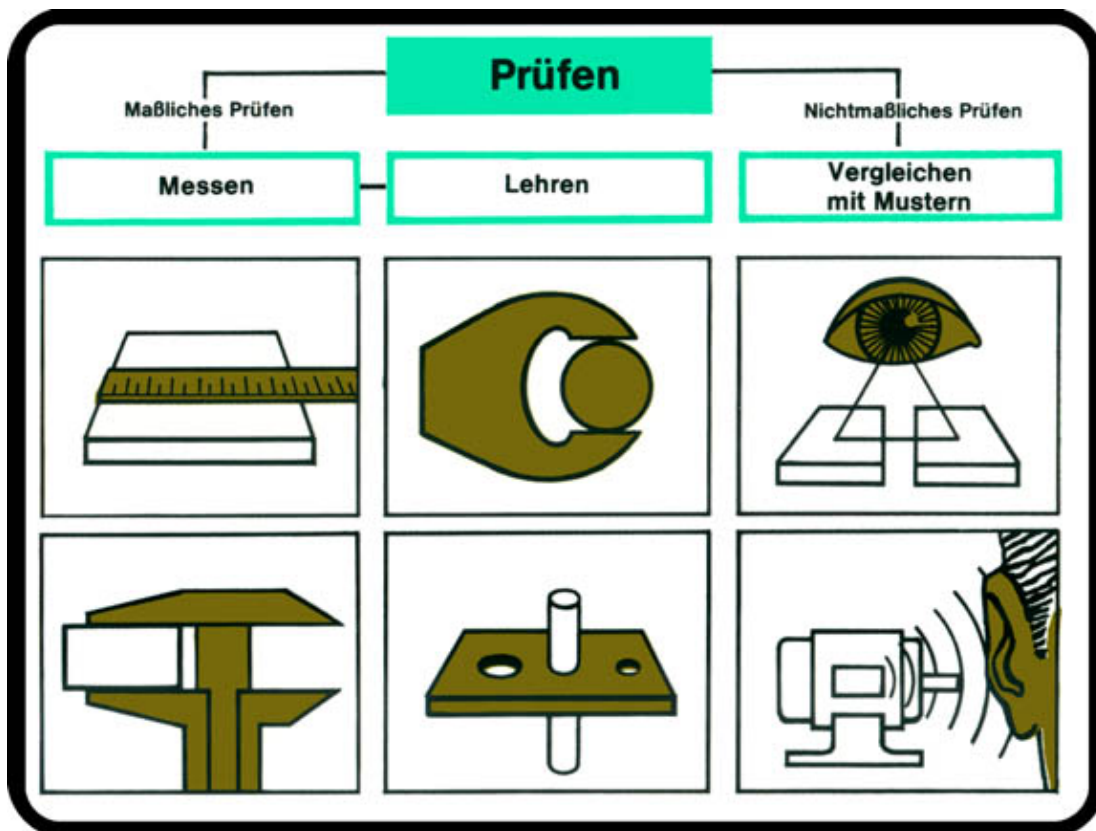

Film no. 23

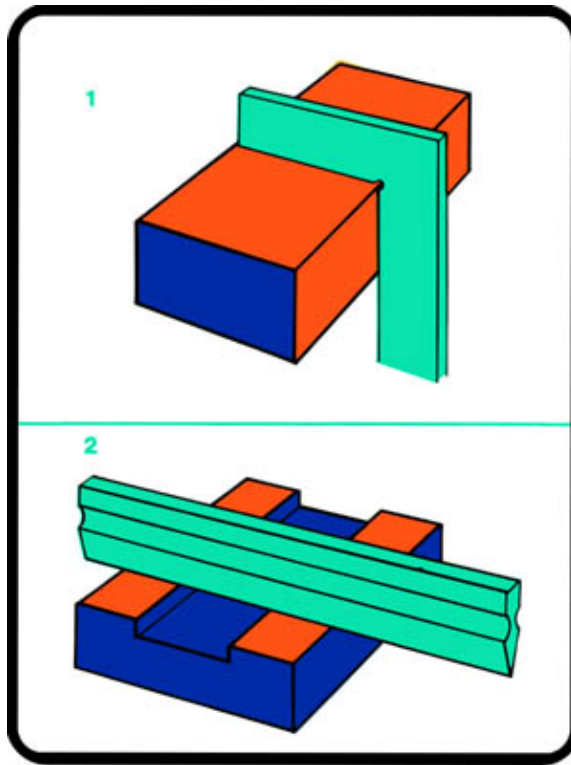

Film no. 24

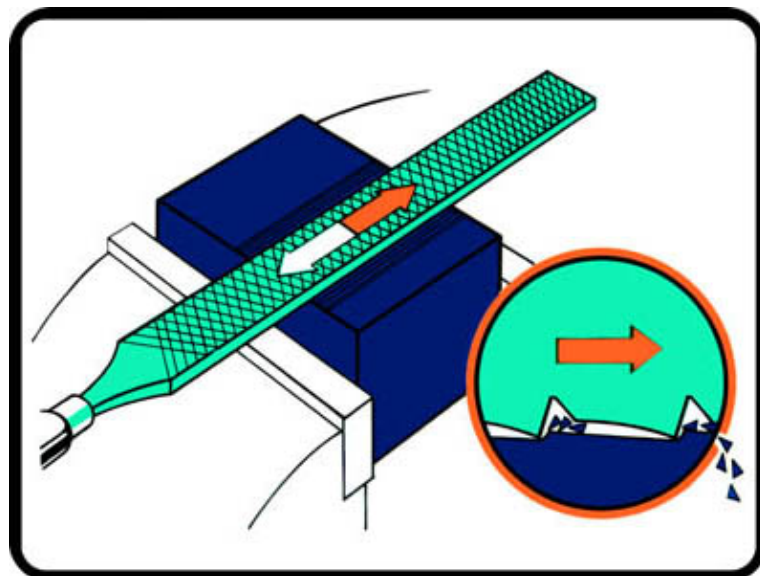

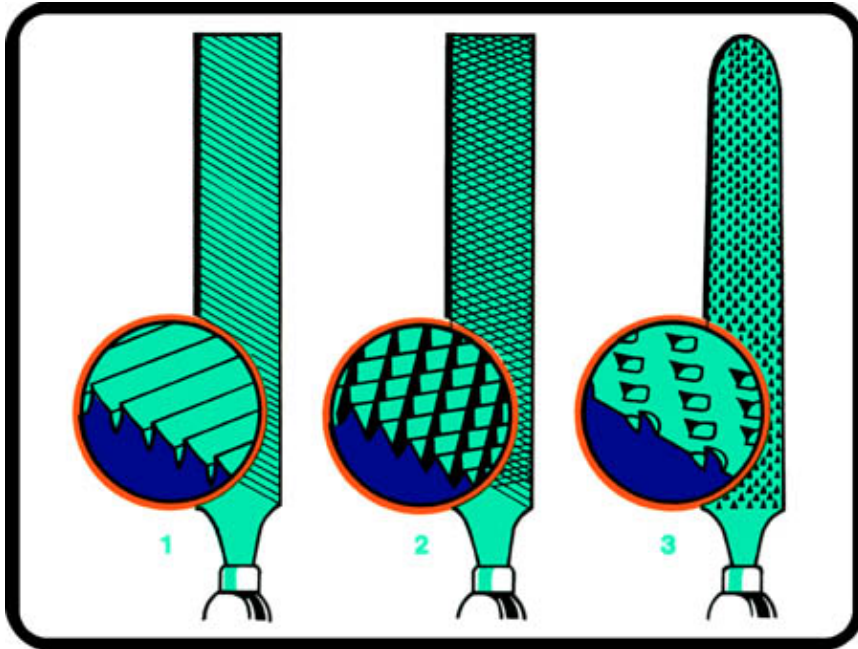

Film no. 26

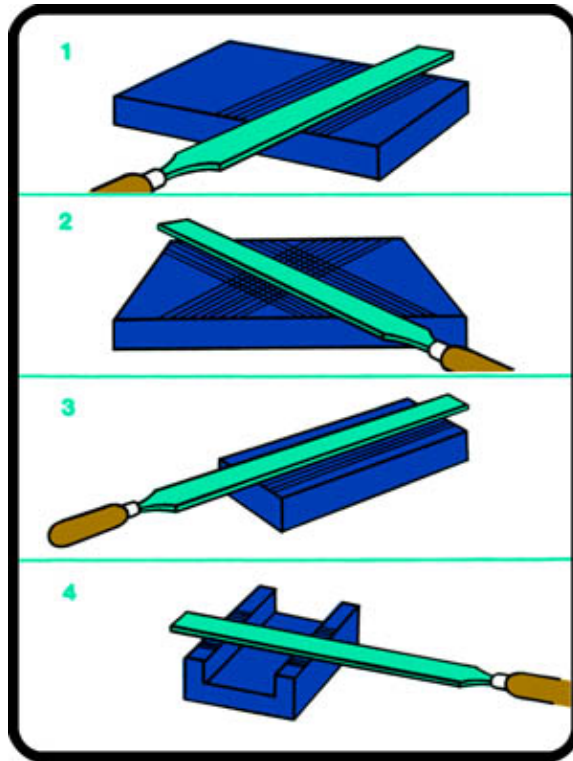

Film no. 27

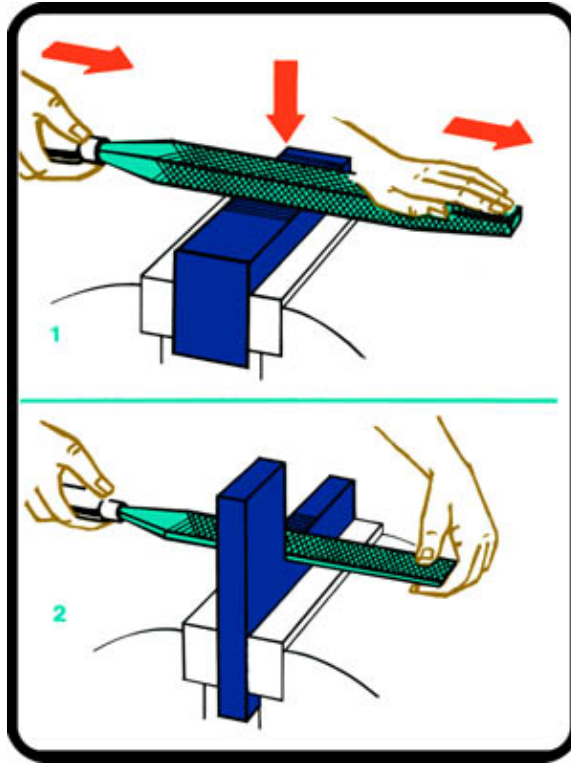

Film no. 28

