

**Illustrated Knowledge Metal Engineering/Basic – Bildreihen für die
Grundstufe Metall**

Table of Contents

Illustrated Knowledge Metal Engineering/Basic – Bildreihen für die Grundstufe Metall	1
1. Measuring and testing – Messen und Testen.....	1
2. Marking/Punch marking – Markierung/Schlagstempelmarkierung.....	11
3. Chipping – Meißeln.....	16
4. Shearing – Scheren.....	20
5. Angled tools/Keyed angles – Winkel am Werkzeug/Keilwinkel.....	25
6. Sawing manual – Sägen.....	29
7. Filing – Feilen.....	34
8. Drilling, Counterboring, Countersinking – Bohren, Reiben.....	40
9. Turning – Drehen.....	51
10. Shaping – Hobeln.....	65
11. Thread cutting – Gewinde schneiden.....	71
12. Threaded joints – Schraubenverbindungen.....	78
13. Keyed joints – Keilverbindungen.....	86
14. Soldering joints – Lötverbindungen.....	93
15. Welded joints – Schweißverbindungen.....	98
16. Folding/Bending – Umformen/Biegen.....	106

Illustrated Knowledge Metal Engineering/Basic – Bildreihen für die Grundstufe Metall

Helmut Pfisterer



Holland + Josenhans Verlag Stuttgart Bestell – Nr. 3004

4. Auflage 1982

© Holland + Josenhans Verlag, Postfach 518, D-7000 Stuttgart 1
Druck: Offsetdruckerei Karl Gramlich, Pliezhausen
ISBN 3-7782-3004-2

1. Measuring and testing – Messen und Testen

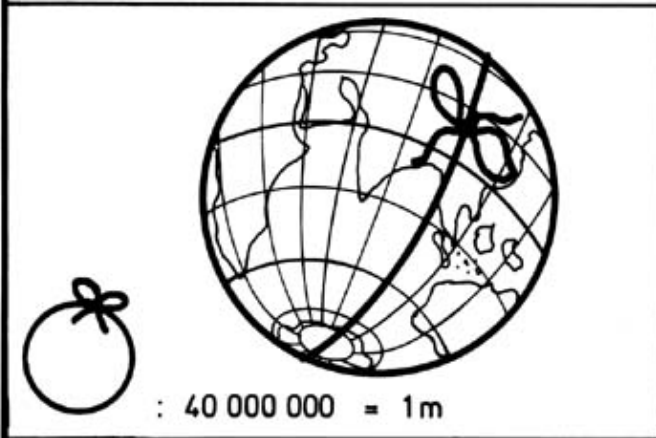

_____ 1.1

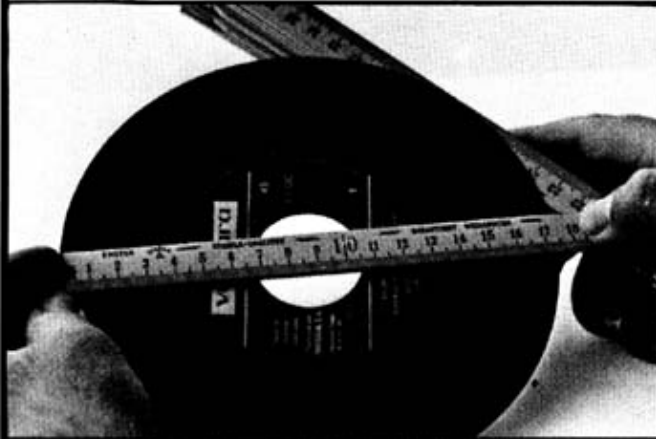

_____ 1.2

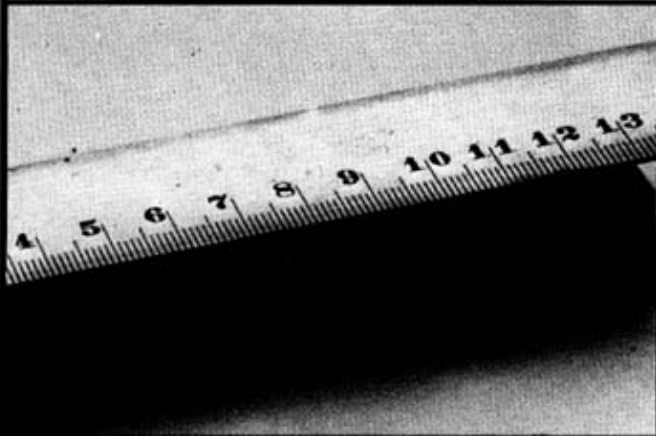

_____ 1.3



_____ 1.4



_____ 1.5

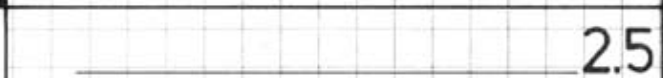
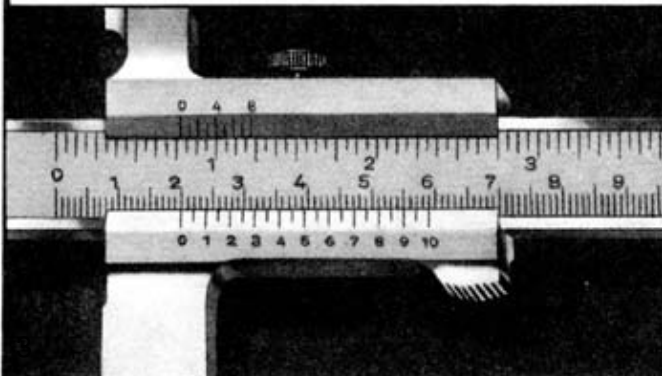
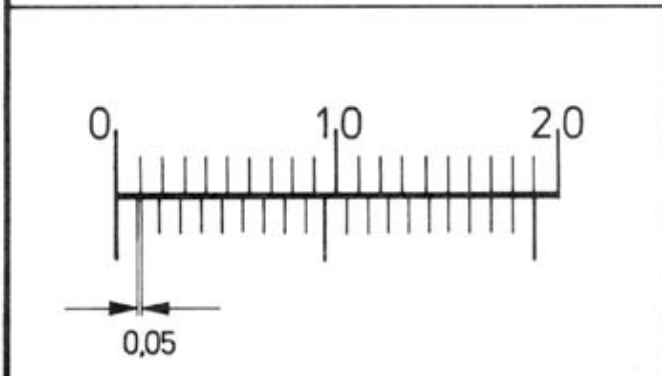
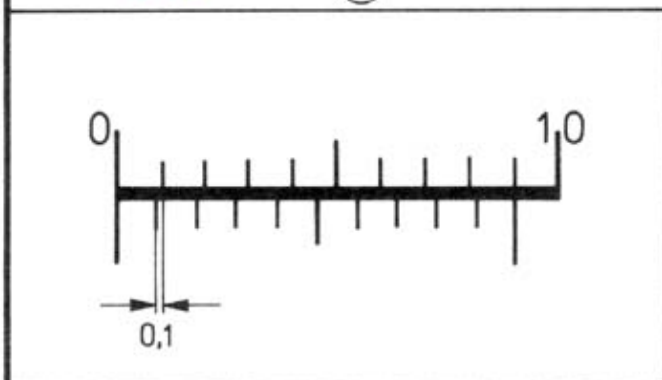
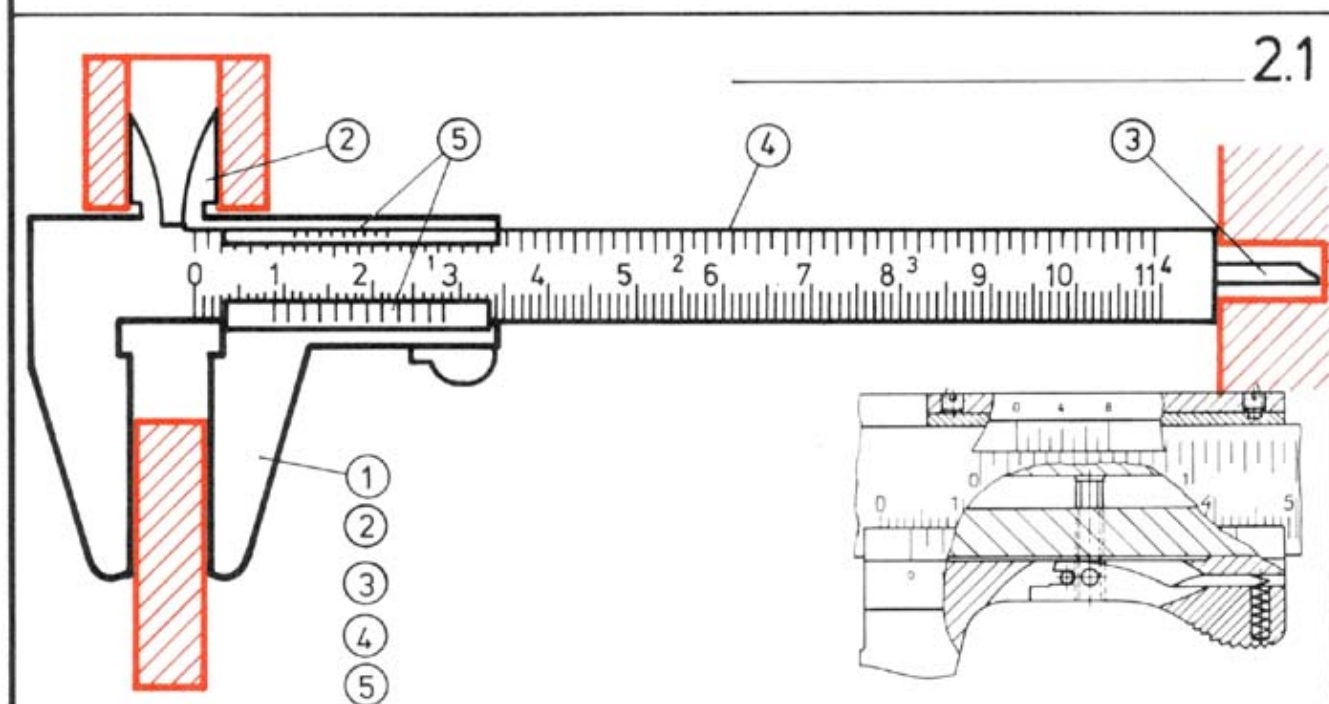

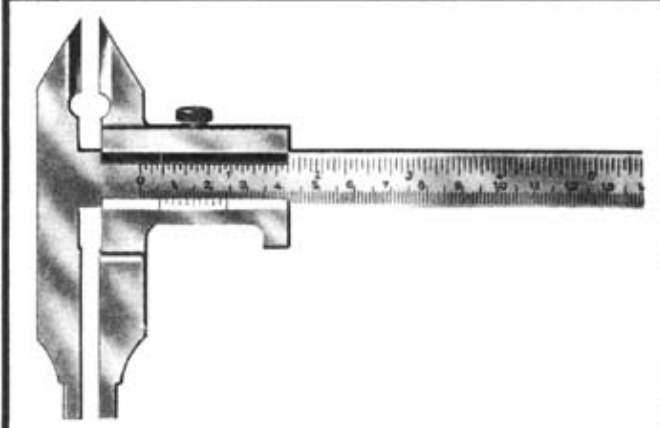

3.1

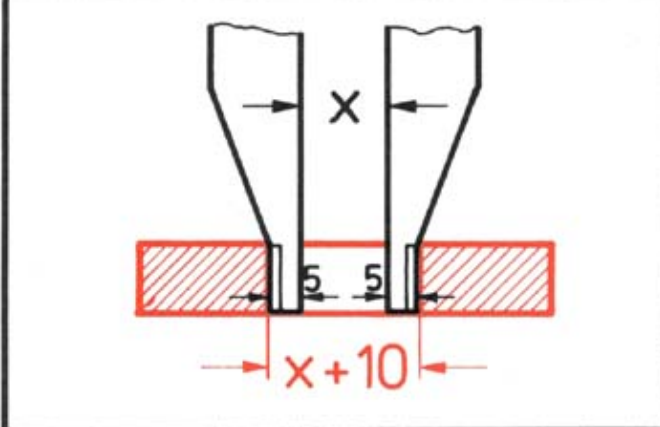

3.2

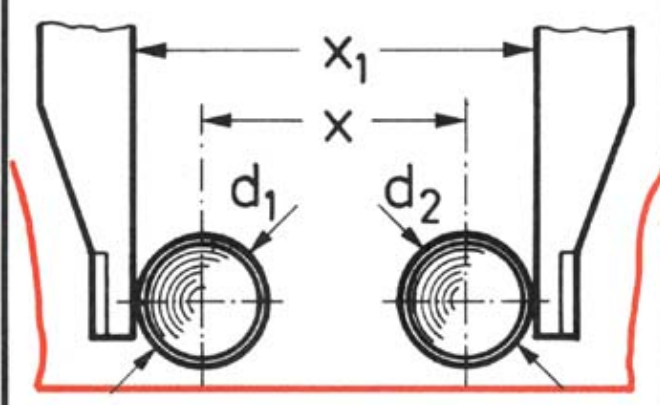

3.3

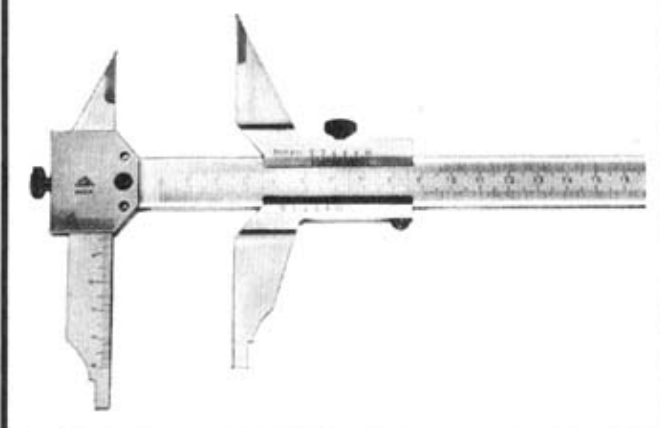

3.4



3.5

3a

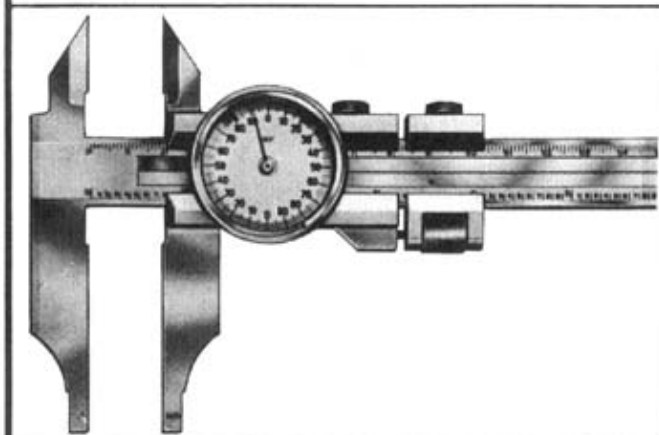

3.1



3.2



3.3

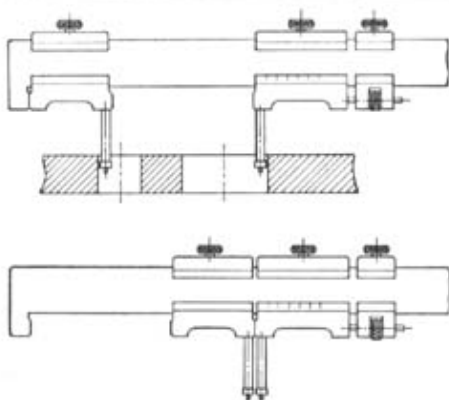

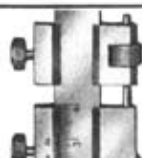

3.4

5

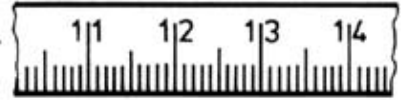

3.5

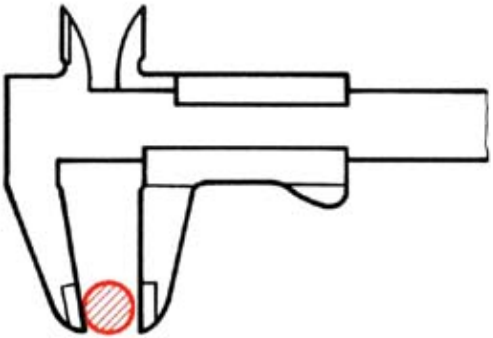
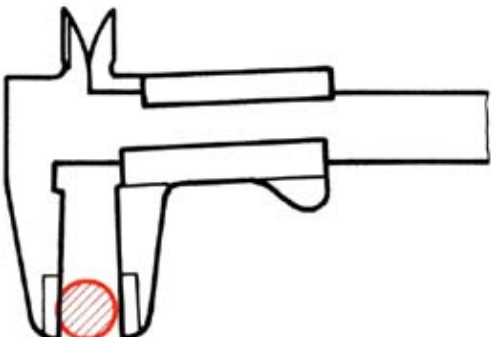
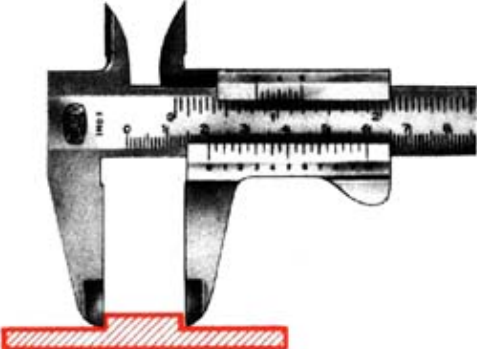
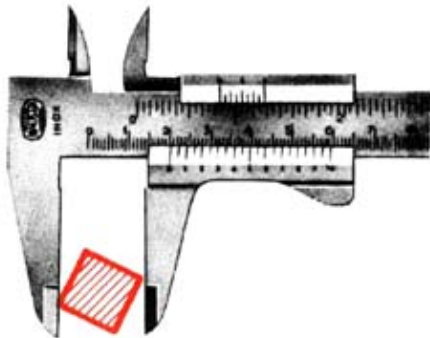

	<p>_____ 4.1</p>
	<p>_____ 4.2</p>
	<p>_____ 4.3</p>
	<p>_____ 4.4</p>
	<p>_____ 4.5</p>

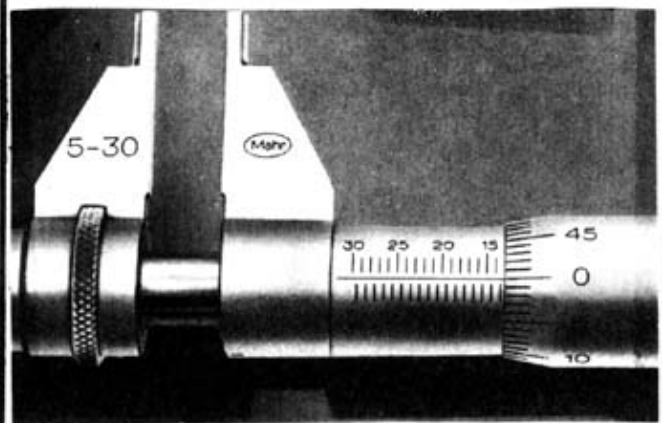
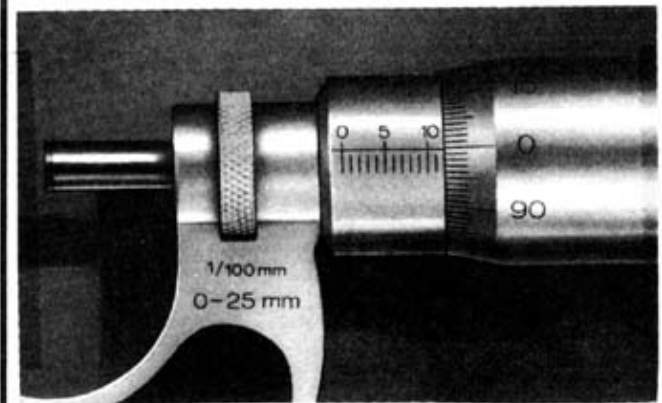
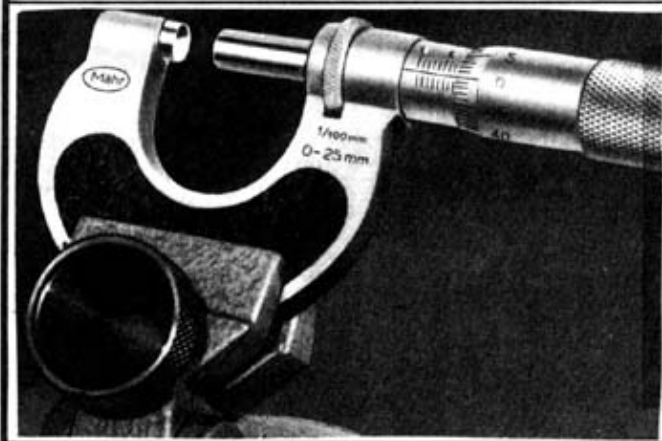
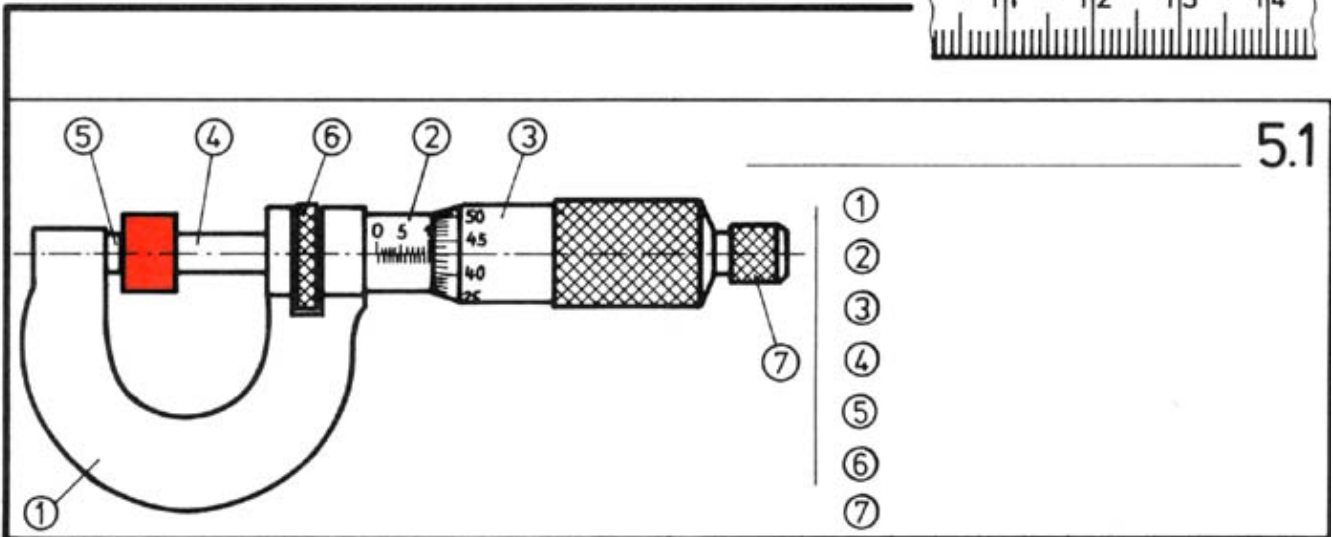

5.1

5.2

5.3

5.4

5.5

5a

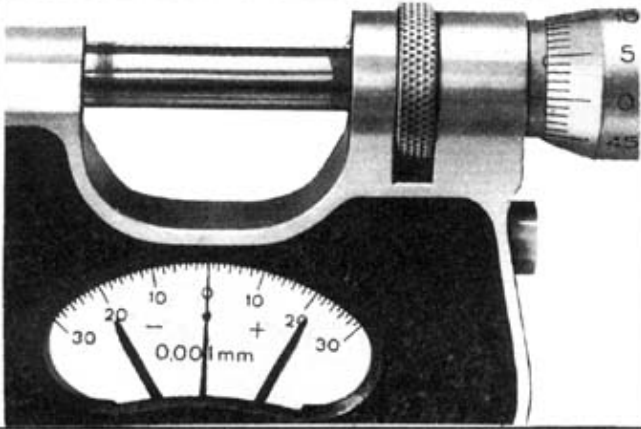

5.1

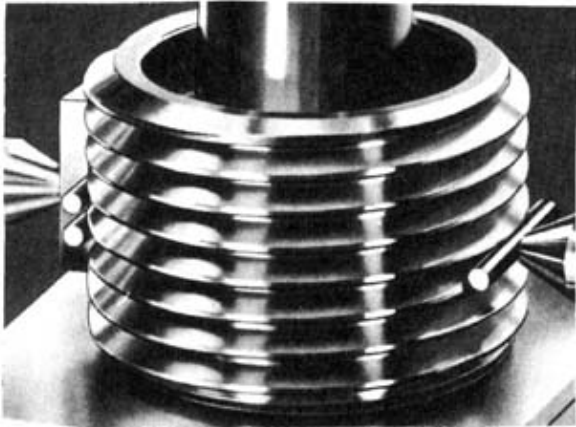

5.2

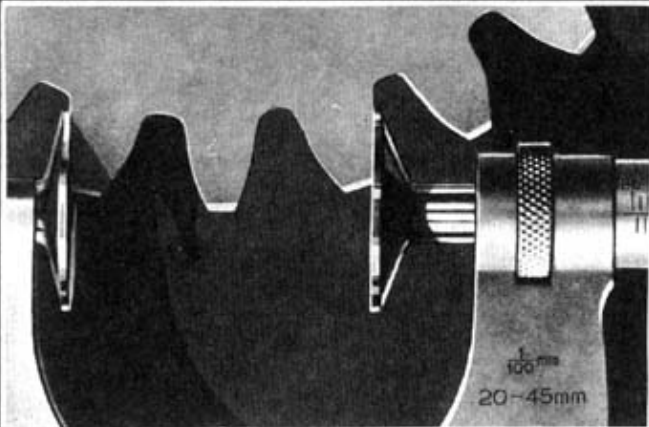

5.3

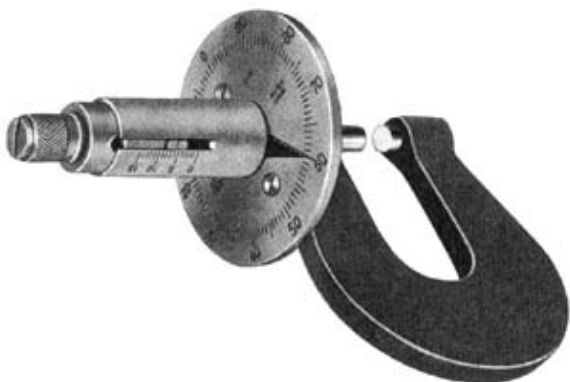

5.4



5.5

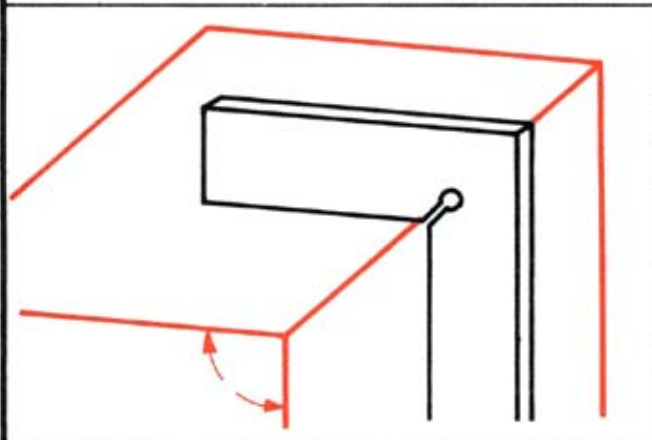

_____ 6.1

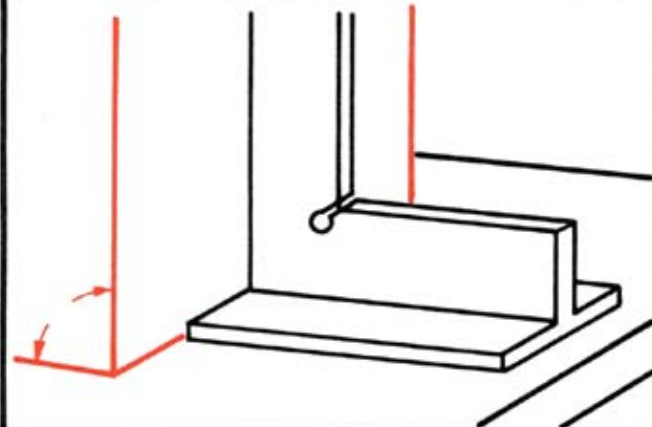

_____ 6.2

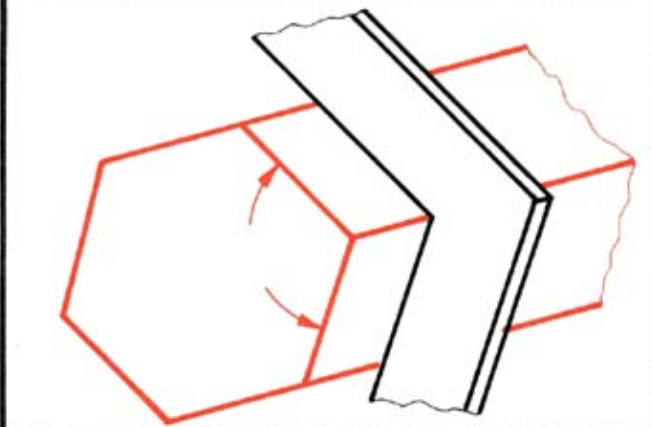

_____ 6.3

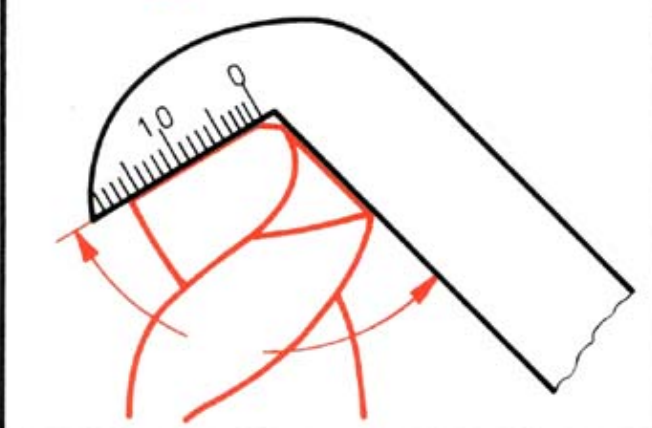

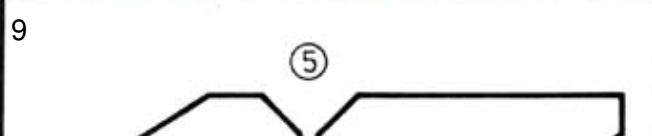

_____ 6.4



9 _____ 6.5

①

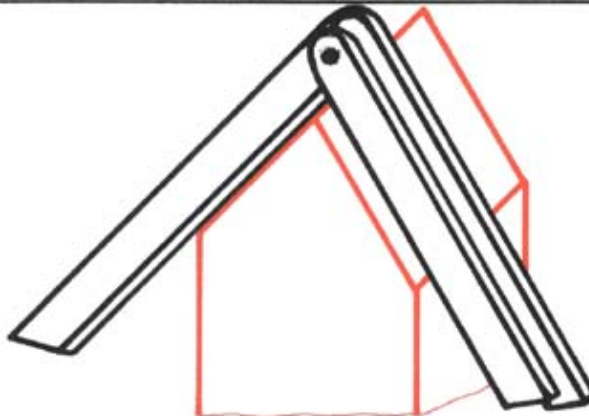
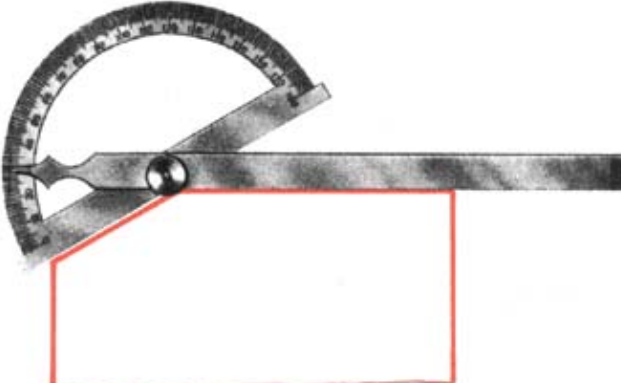
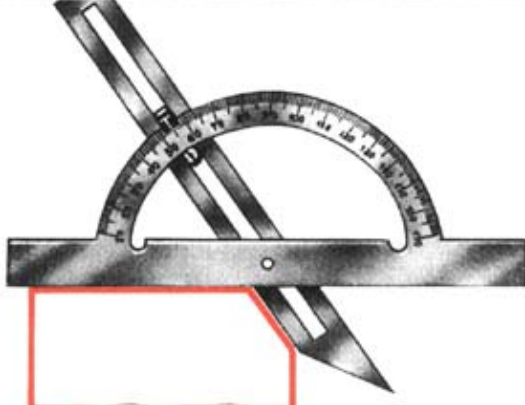
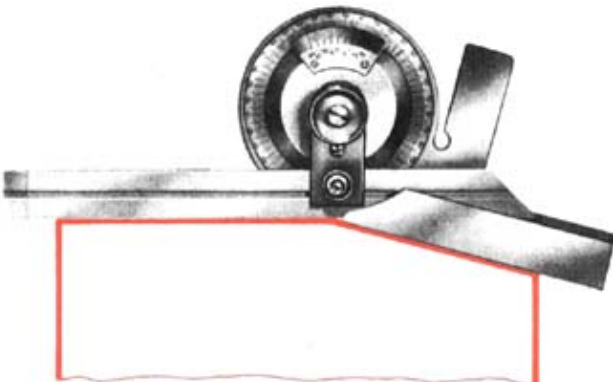

	<p>_____ 7.1</p>
	<p>_____ 7.2</p>
	<p>_____ 7.3</p>
	<p>_____ 7.4</p>
	<p>_____ 7.5</p>

2. Marking/Punch marking – Markierung/Schlagstempelmarkierung

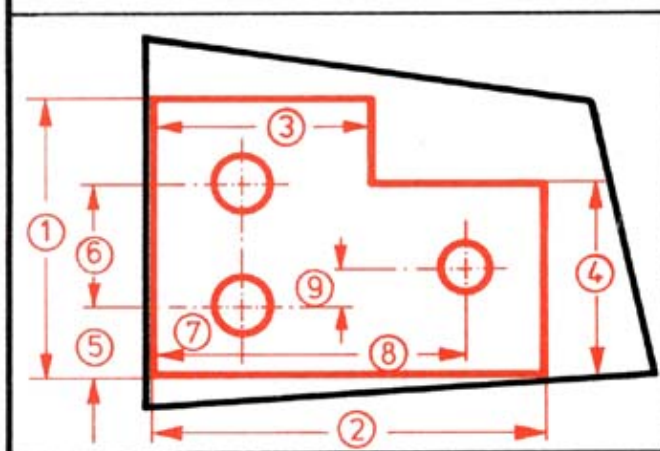

1.1

①
② ③
④
⑤ ⑥ ⑨
⑦ ⑧

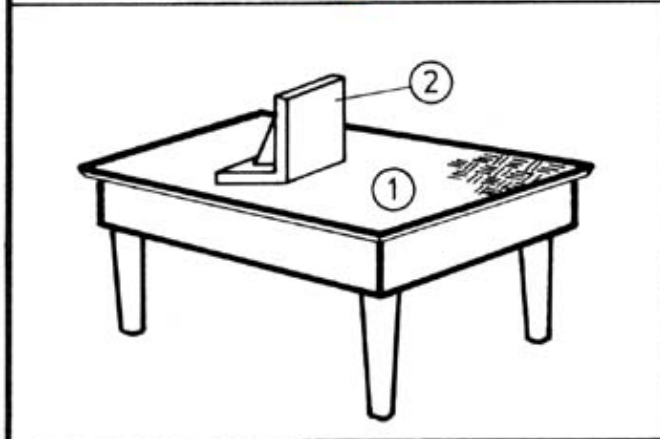

1.2

①
②

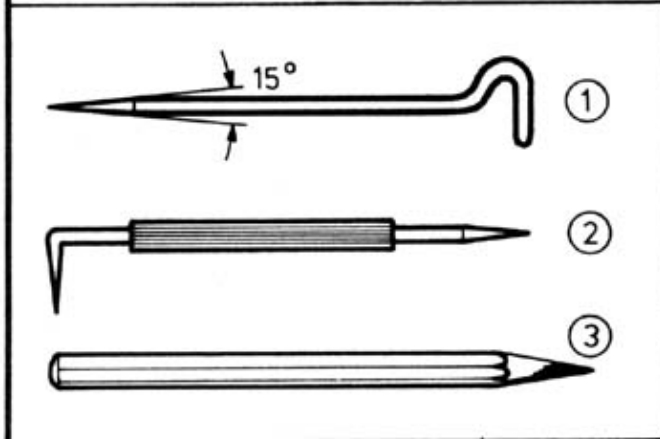

1.3

①
②
③

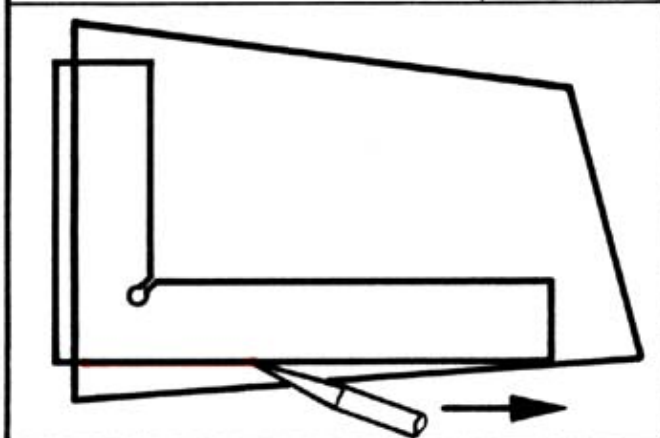

1.4

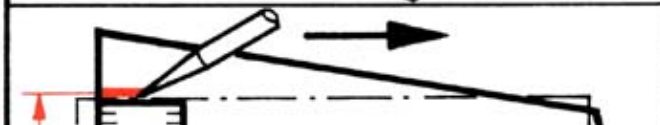







1.5¹²

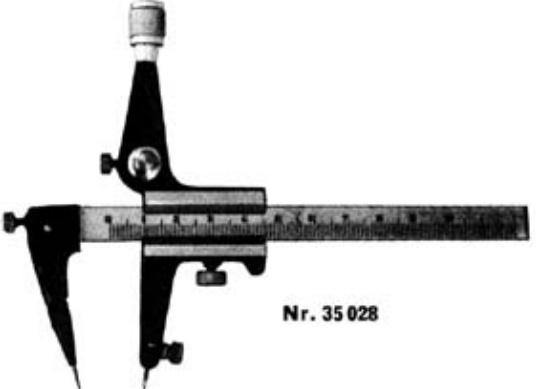

	2.1 <hr/>
	2.2 <hr/>
	2.3 <hr/>
	2.4 <hr/>
13 	2.5 <hr/>



	<p>_____ 3.1</p> <p>①</p> <p></p> <p>②</p>
	<p>_____ 3.2</p> <p></p>
	<p>_____ 3.3</p> <p></p>
	<p>_____ 3.4</p>
	<p>_____ 3.5</p>



	<p style="text-align: right;">4.1</p> <hr/> <p>①</p> <p>②</p> <p>③</p>
	<p style="text-align: right;">4.2</p> <hr/> <p>①</p> <p>②</p> <p>③</p>
	<p style="text-align: right;">4.3</p> <hr/>
	<p style="text-align: right;">4.4</p> <hr/>



3. Chipping – Meißeln

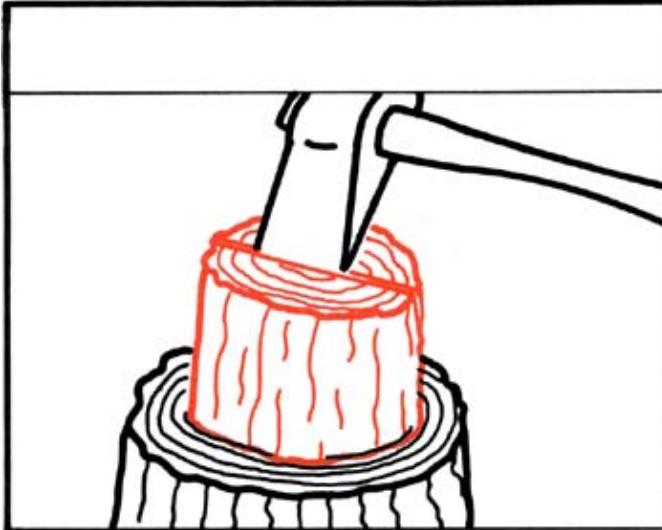
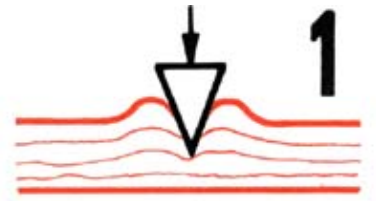

1.1

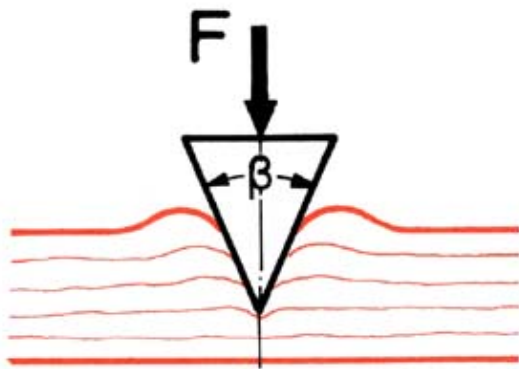

1.2

$$F =$$

$$\sphericalangle \beta =$$

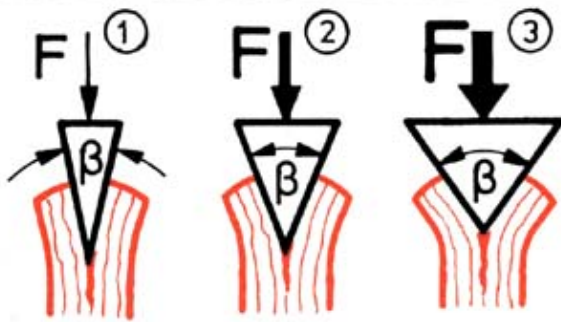

1.3

- ①
- ②
- ③

$$\sphericalangle \beta \hat{=} F$$

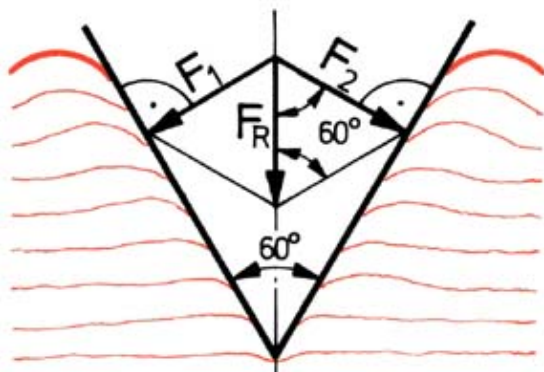

1.4

$$F_1 = F_2$$

$$\sphericalangle 60^\circ: F_R = F_1 = F_2$$

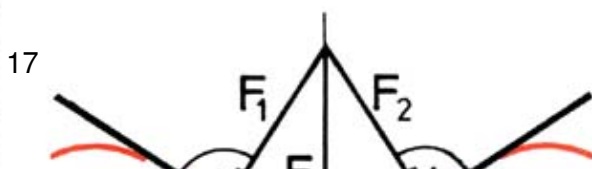

1.5

$$F_1 = F_2 < F_R$$

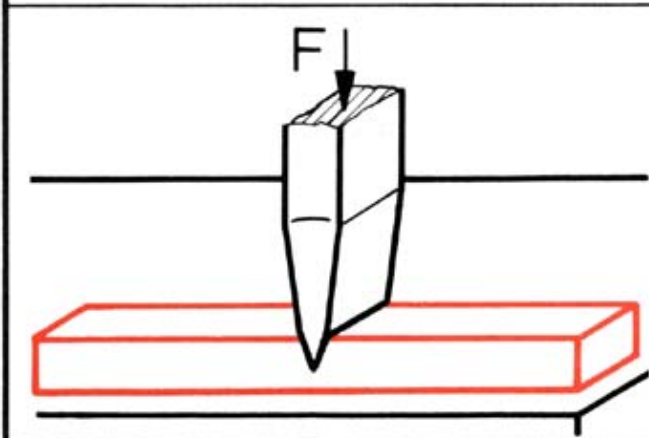
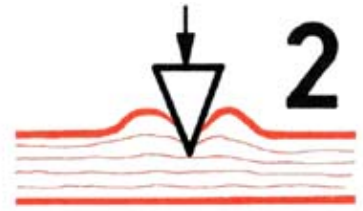

2.1

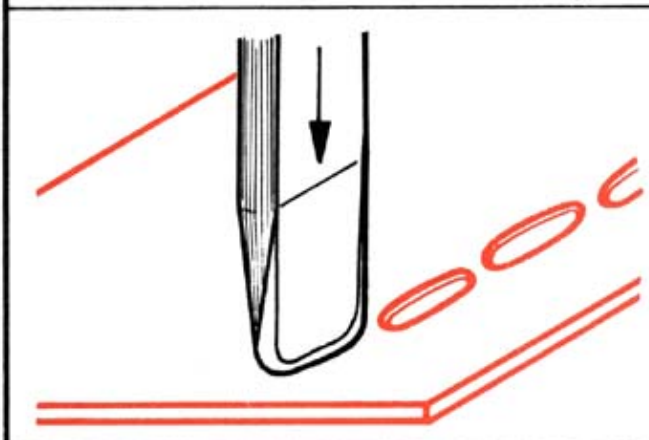

2.2

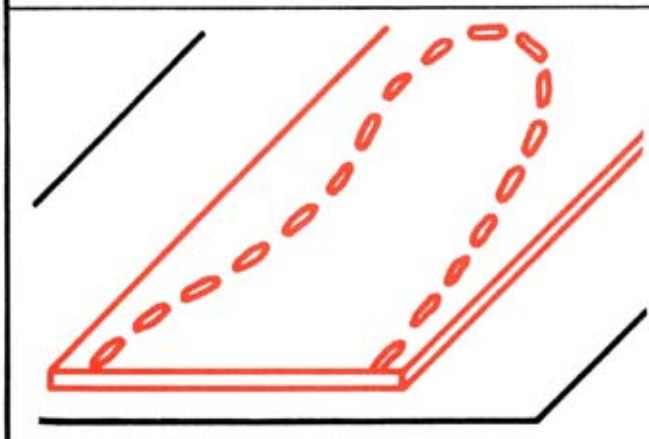

2.3

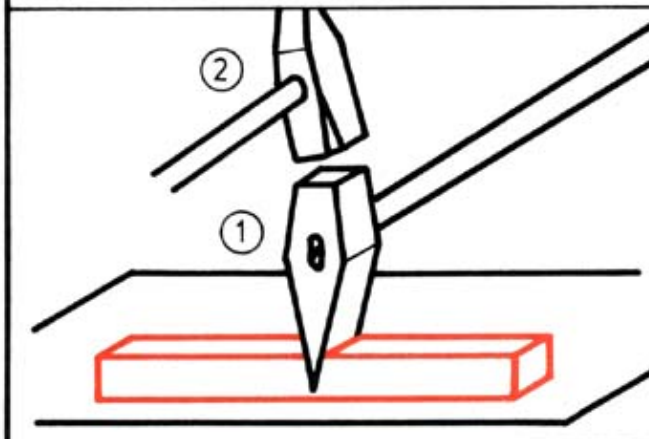

2.4

- ①
- ②



2.5

- ①
- ②

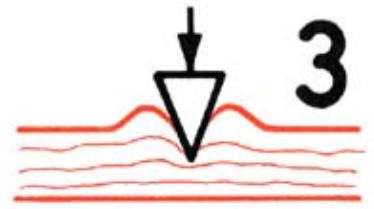

	<p style="text-align: right;">3.1</p> <p>①</p> <p>②</p>
	<p style="text-align: right;">3.2</p> <p style="text-align: center;">$F \cdot S = F \cdot S$</p>
	<p style="text-align: right;">3.3</p>
	<p style="text-align: right;">3.4</p> <p>①</p> <p>②</p>
	<p style="text-align: right;">3.5</p> <p>①</p>

4. Shearing – Scheren

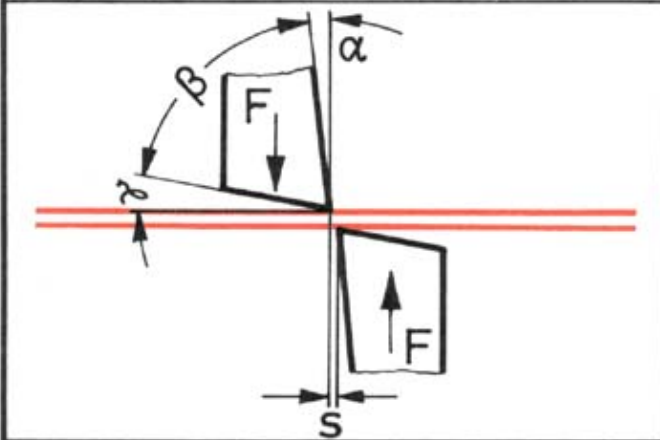
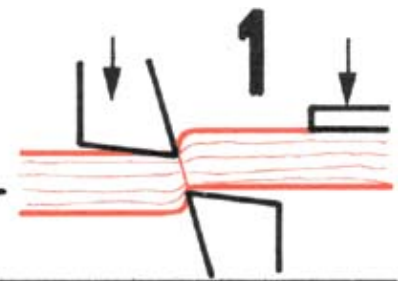

_____ 1.1

$\sphericalangle \alpha = 2 \dots 4^\circ =$
 $\sphericalangle \beta = 75 \dots 82^\circ =$
 $\sphericalangle \gamma = 5 \dots 13^\circ =$

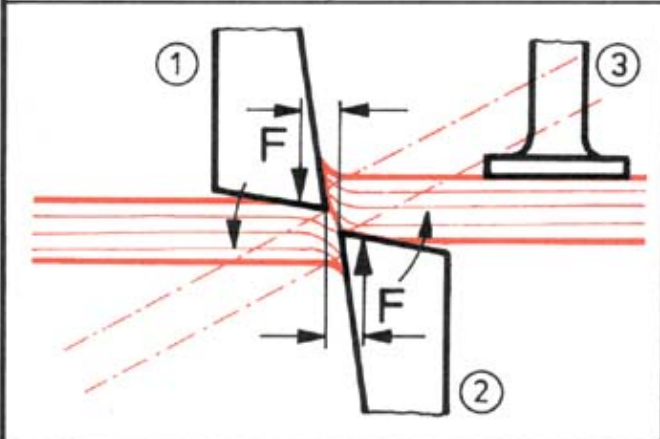

_____ 1.2

①
 ②
 ③

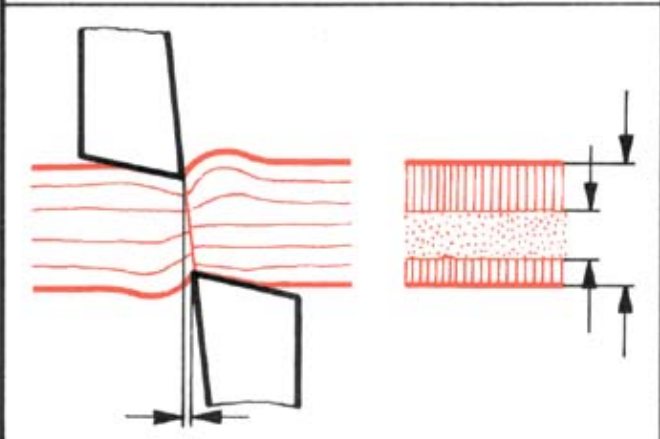

_____ 1.3

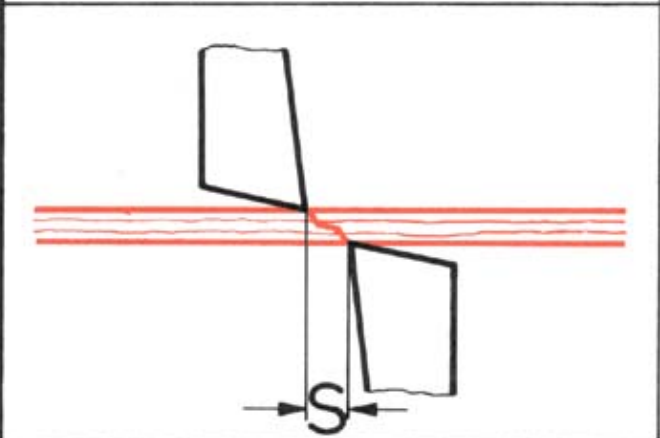

_____ 1.4



_____ 1.5

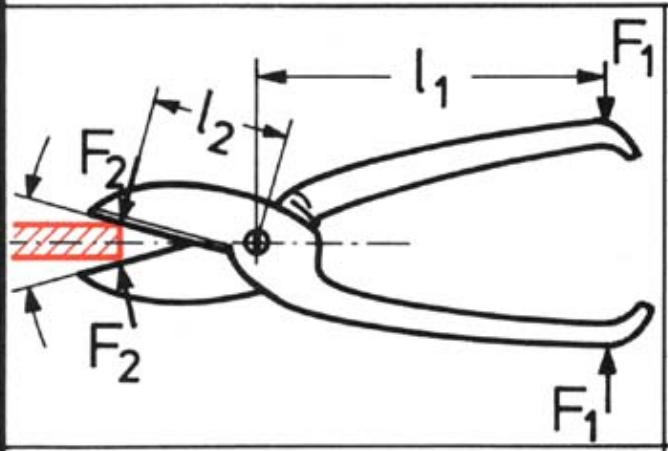
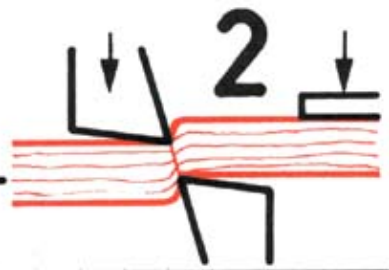

2.1

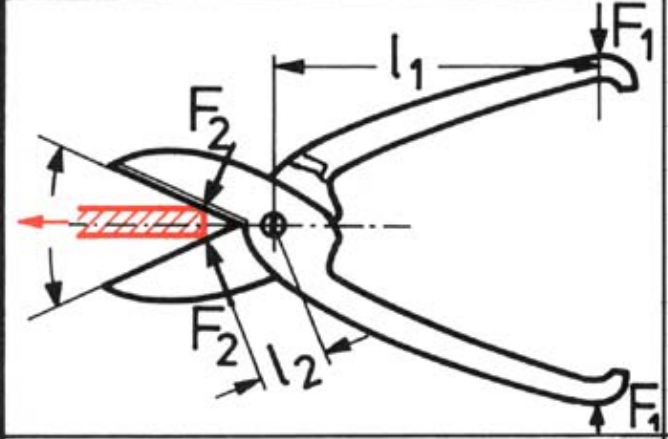

2.2

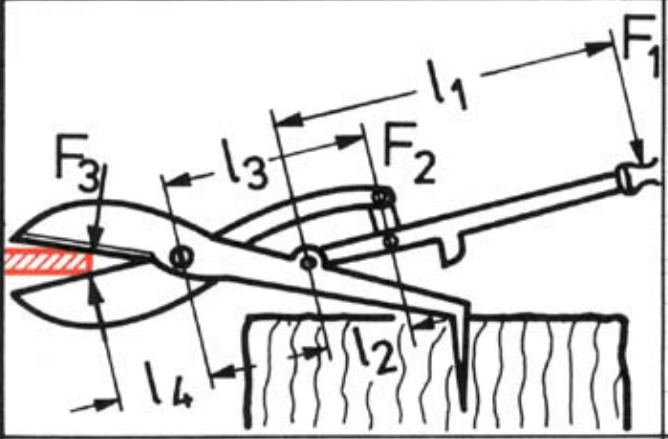

2.3

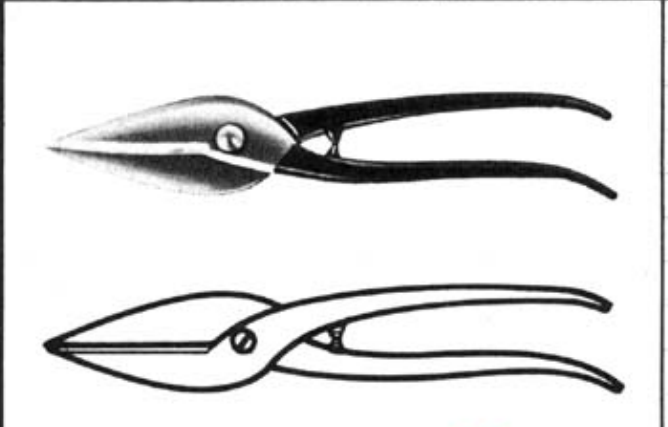

2.4

①

②



2.5

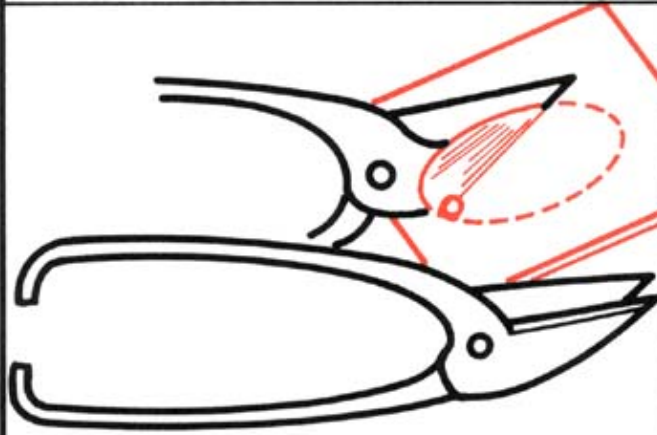
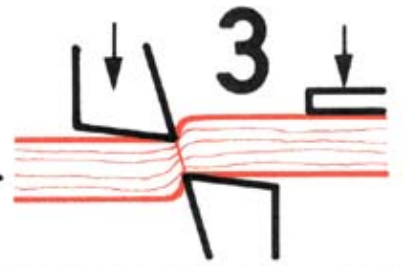

3.1

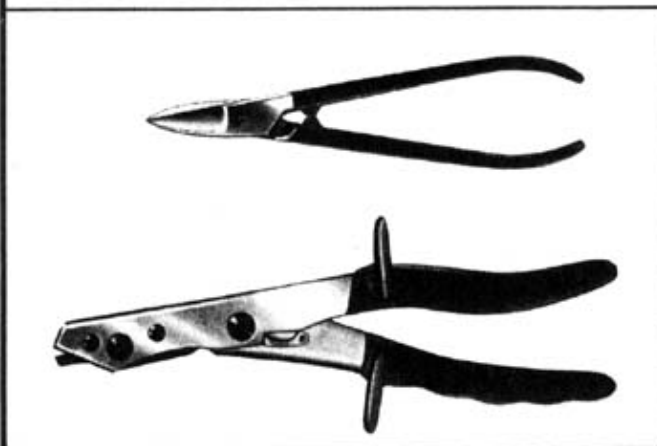

3.2

①

②

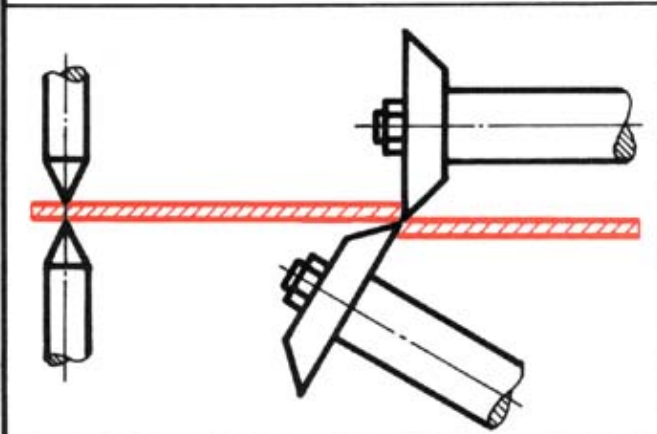

3.3

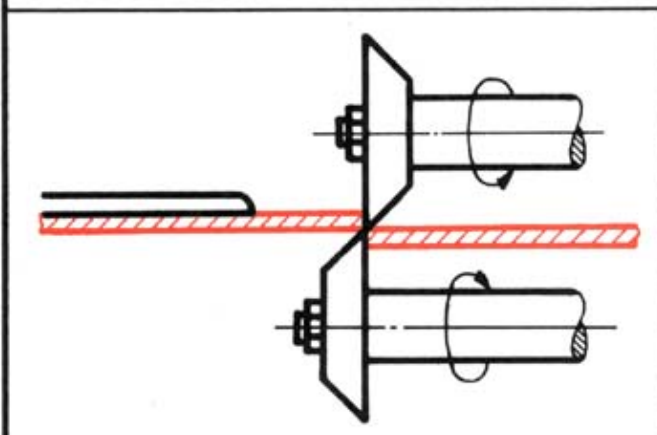

3.4



3.5

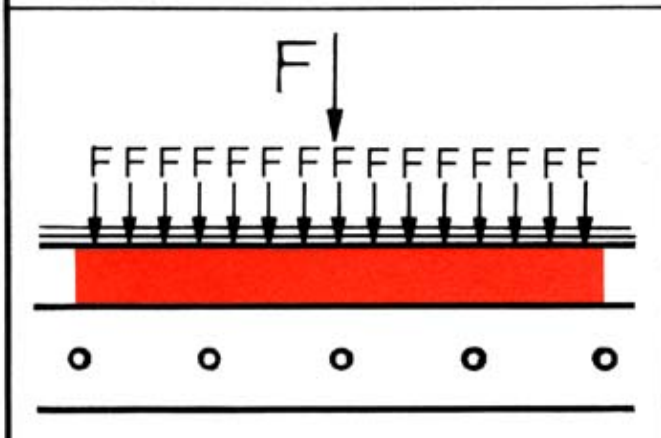
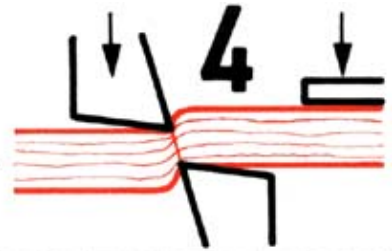

4.1

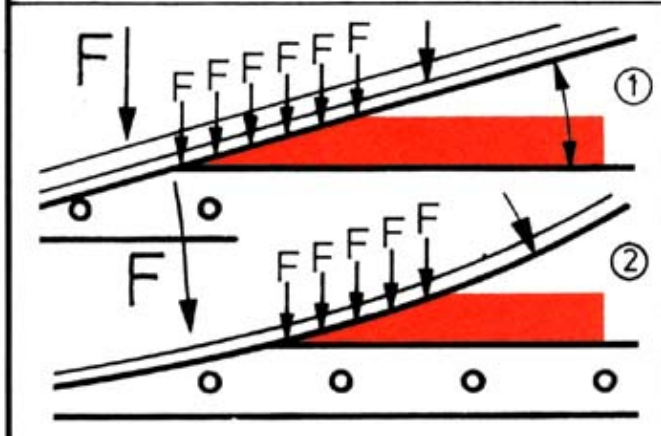

4.2

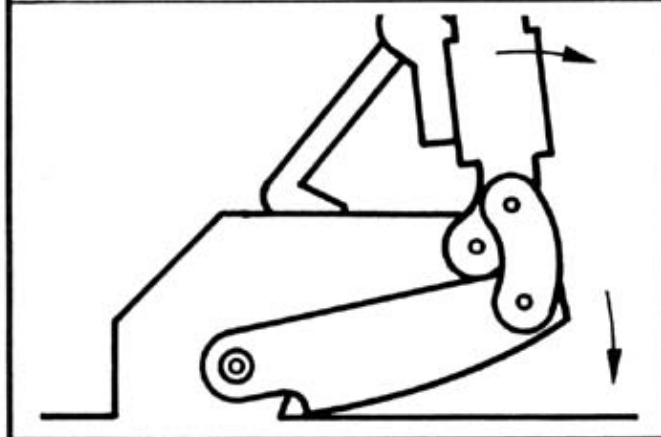

4.3

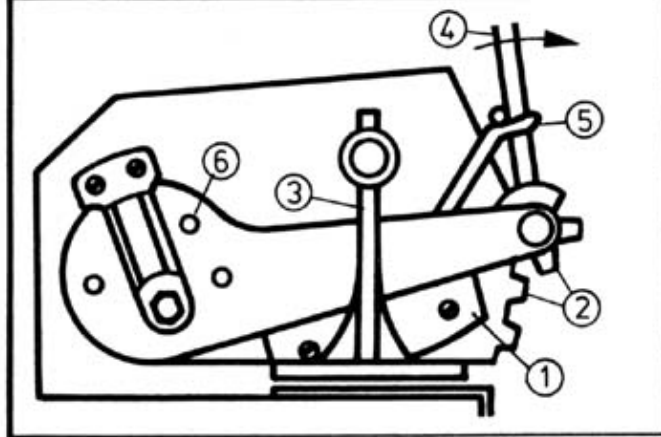

4.4

- ①
- ②
- ③
- ④
- ⑤
- ⑥



4.5

5. Angled tools/Keyed angles – Winkel am Werkzeug/Keilwinkel

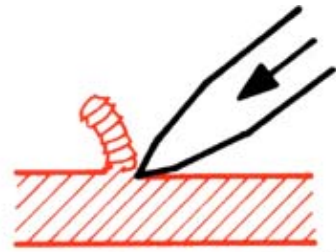

1

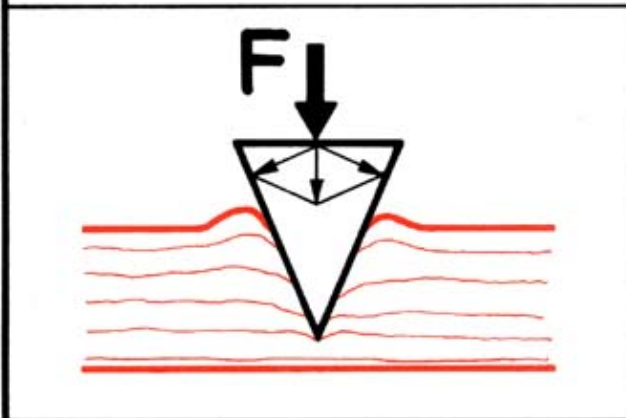

_____ 1.1

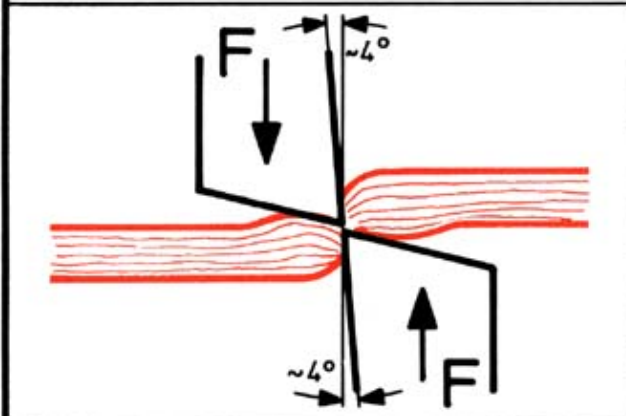

_____ 1.2

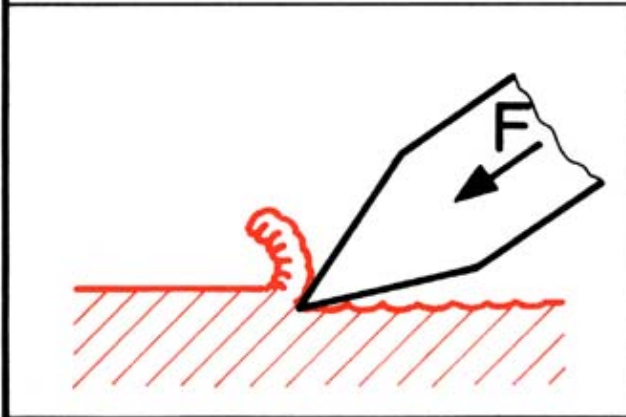

_____ 1.3

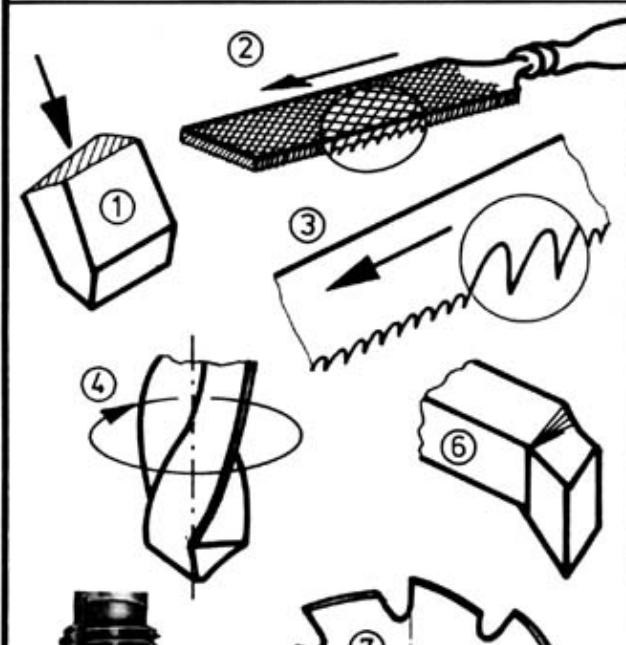

_____ 1.4

- ①
- ②
- ③
- ④
- ⑤
- ⑥
- ⑦

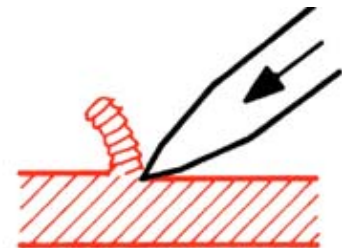

	<p>_____ 2.1</p> <p>① ② ∠α = ∠β = ∠γ =</p>
	<p>_____ 2.2</p> <p>① ② ∠α = ∠β = ∠γ =</p>
	<p>_____ 2.3</p>
	<p>_____ 2.4</p>
	<p>_____ 2.5</p>

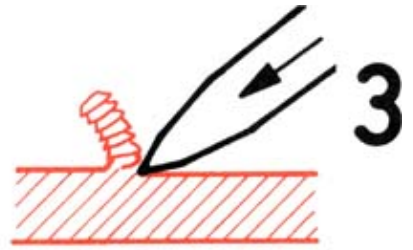

3

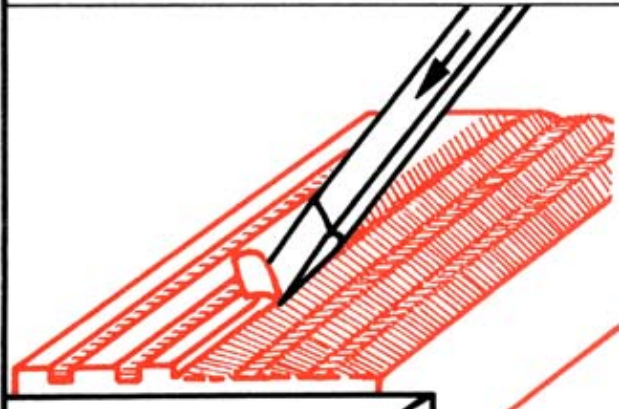

3.1

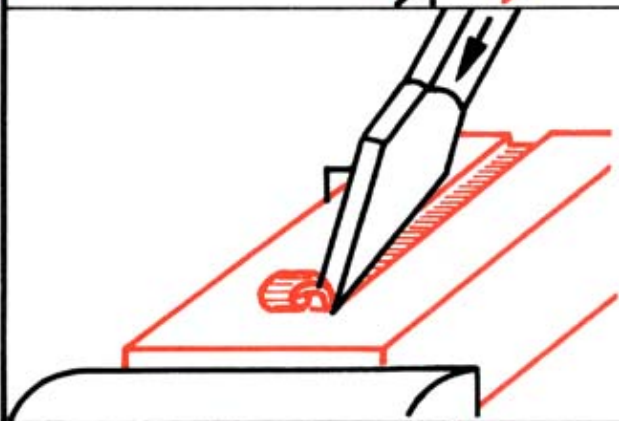

3.2



3.3



3.4



3.5



6. Sawing manual – Sägen

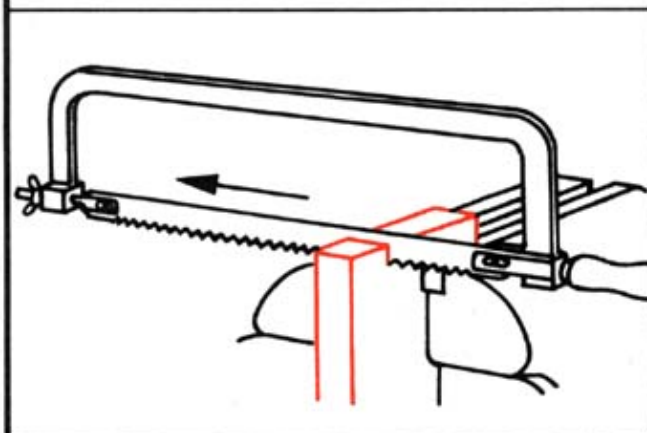
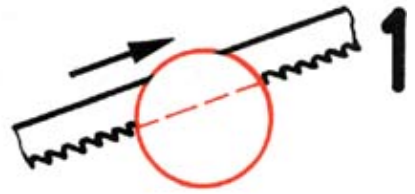

1.1

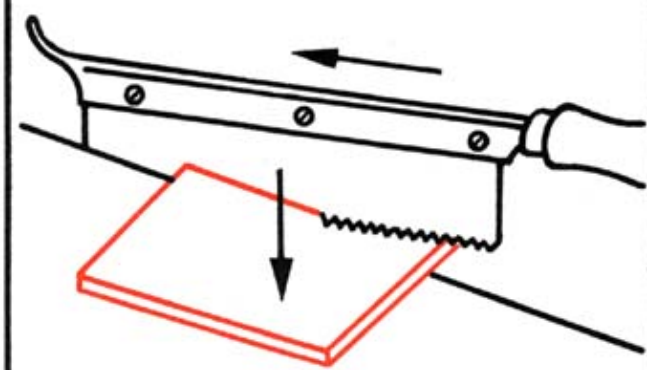

1.2

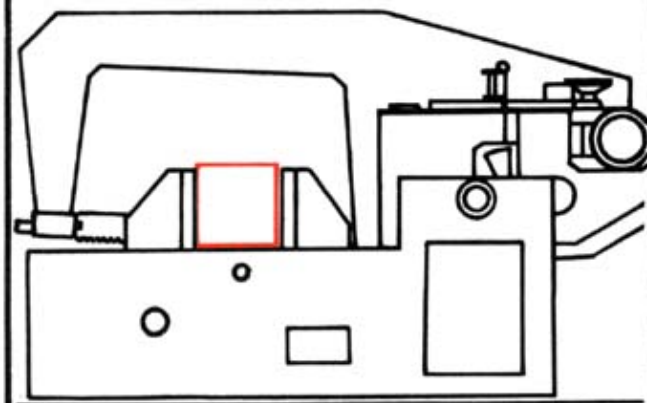

1.3

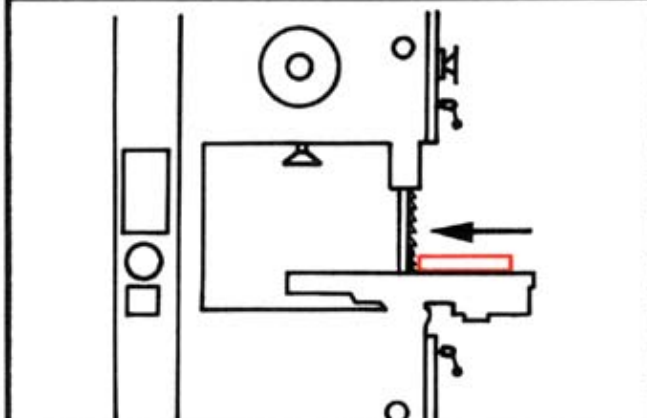

1.4



1.5



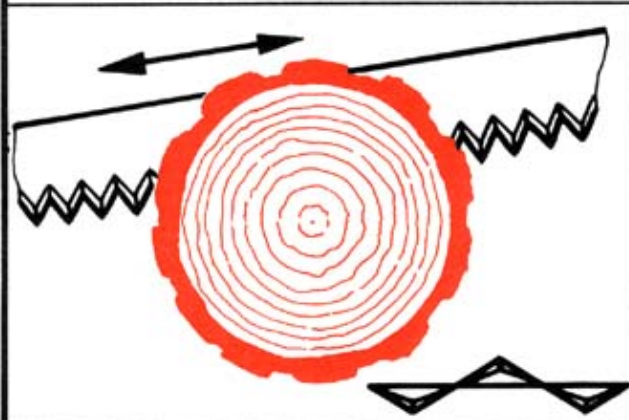
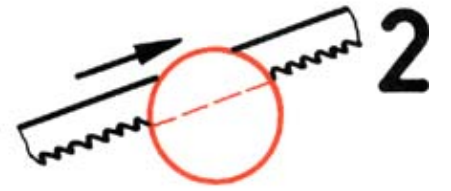

2.1



2.2

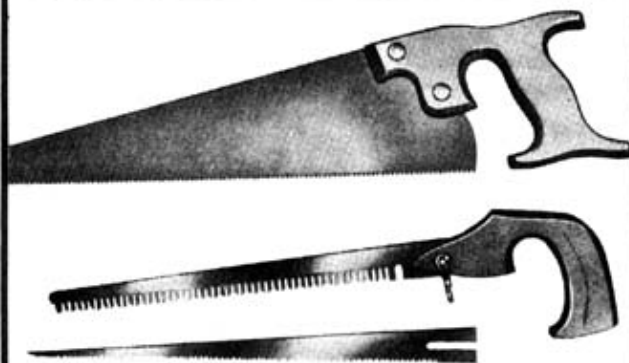

2.3

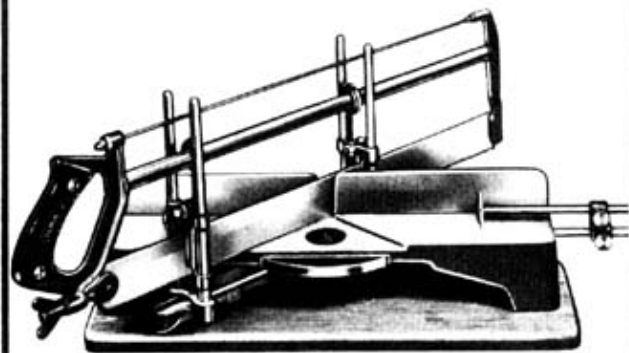

2.4



2.5

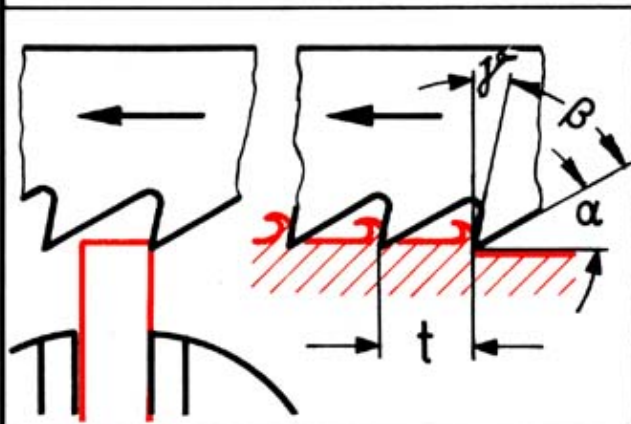

$\sphericalangle \alpha = 30^\circ$
 $\sphericalangle \beta = 50^\circ$
 $\sphericalangle \gamma = 10^\circ$

3.1

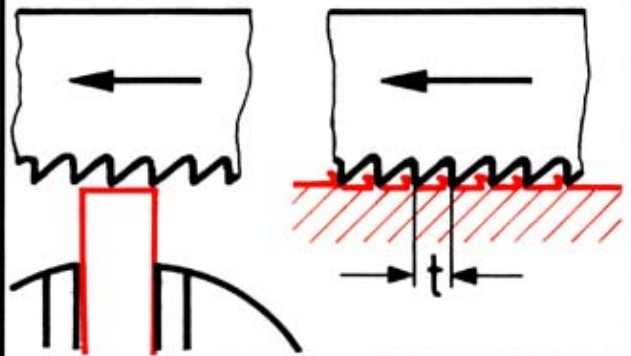

$\sphericalangle \alpha = 40^\circ$
 $\sphericalangle \beta = 50^\circ$
 $\sphericalangle \gamma = 0^\circ$

3.2

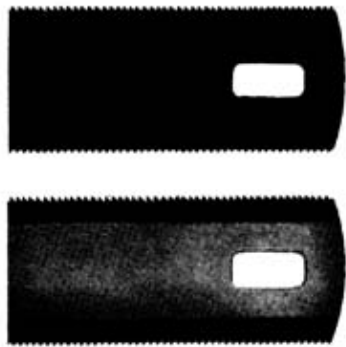

3.3

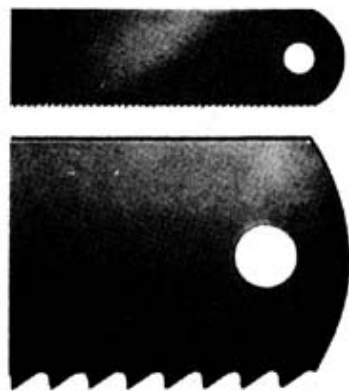

3.4

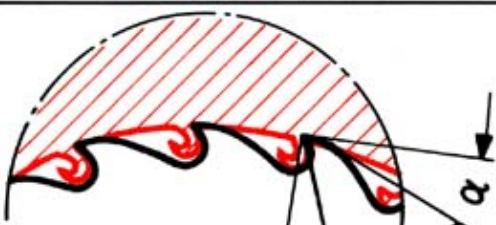

3.5

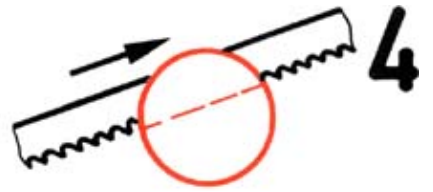

4

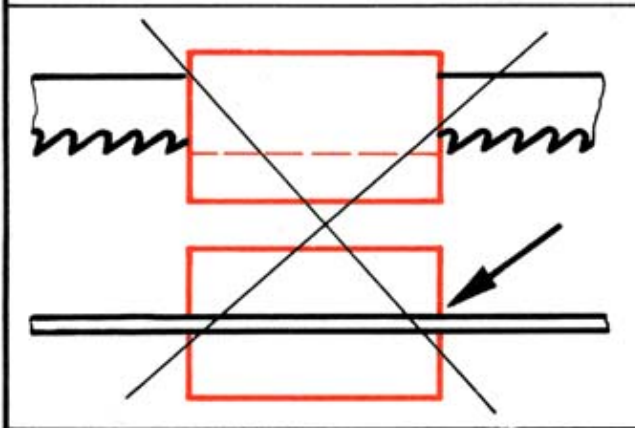

4.1

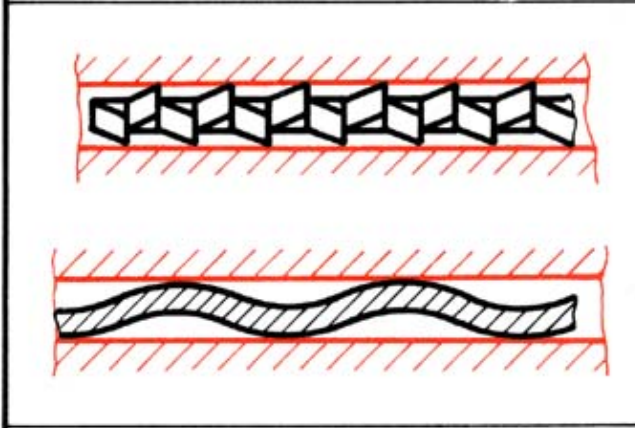

4.2

①

②

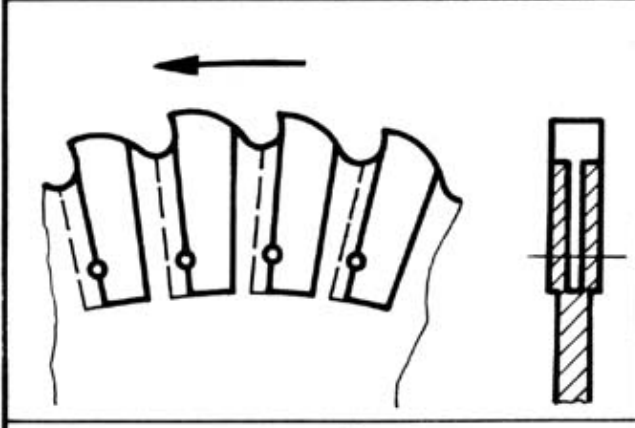

4.3

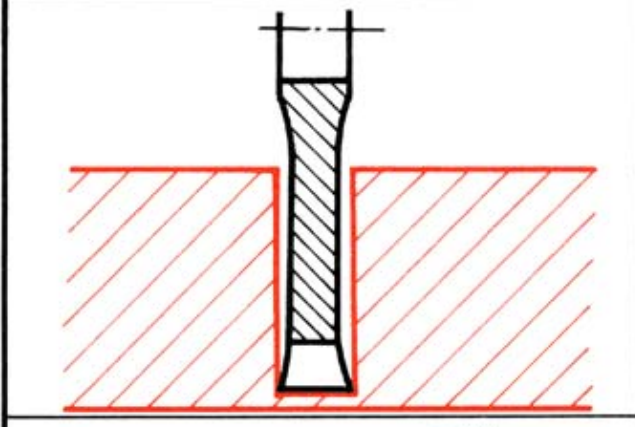

4.4



4.5

33

7. Filing – Feilen



1

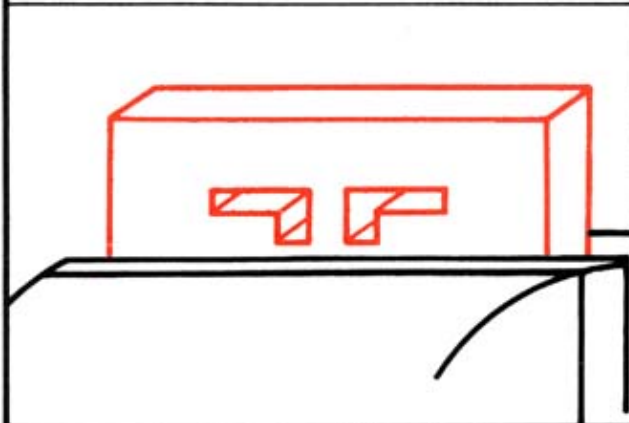

1.1

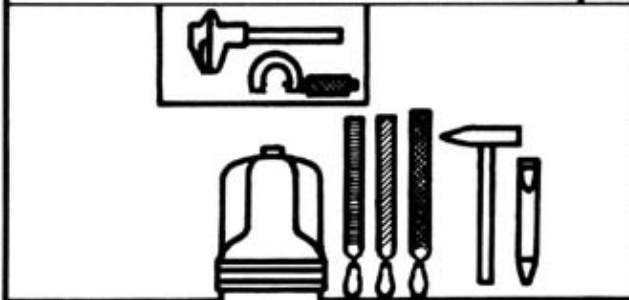

1.2



1.3

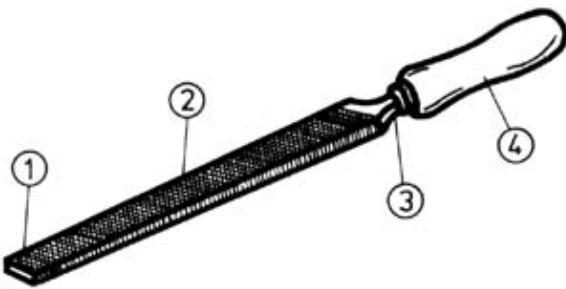

- ①
- ②
- ③
- ④

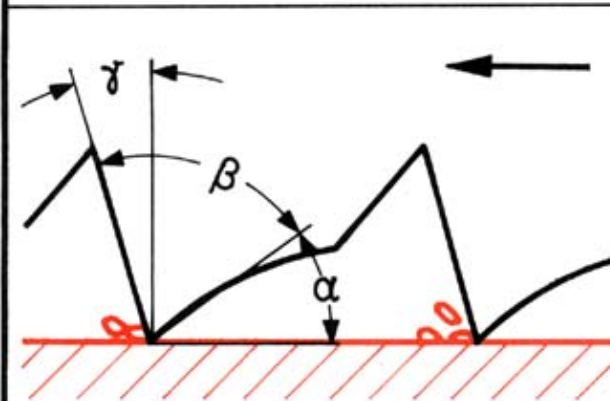

1.4

- ↔ α
- ↔ β
- ↔ γ

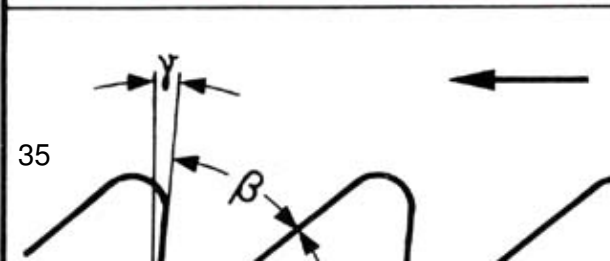

1.5

- ↔ α
- ↔ β
- ↔ γ

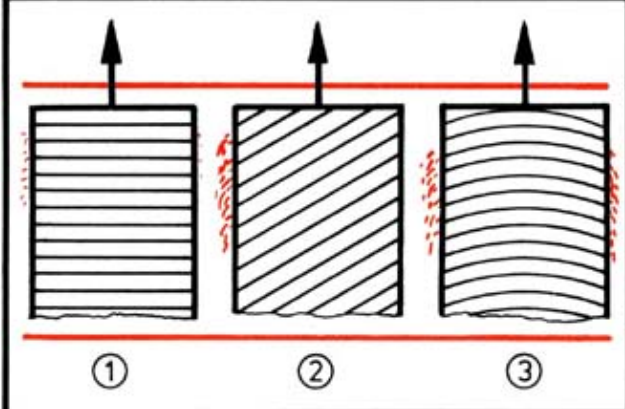

_____ 2.1

①
②
③

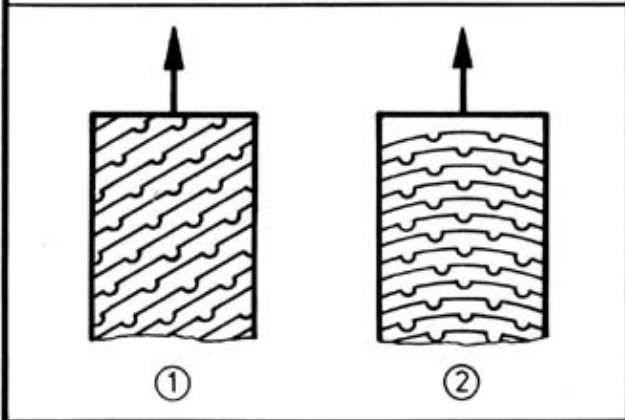

_____ 2.2

①
②

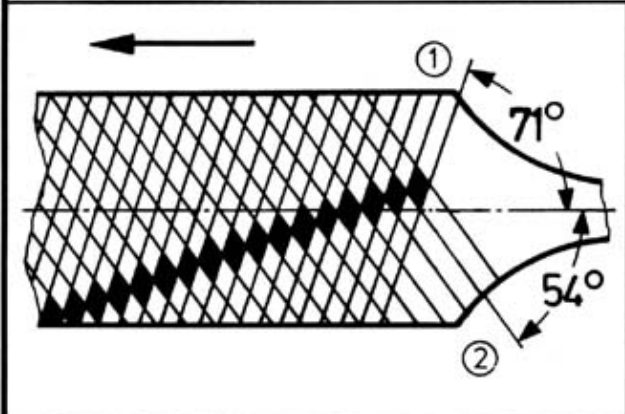

_____ 2.3

①
②

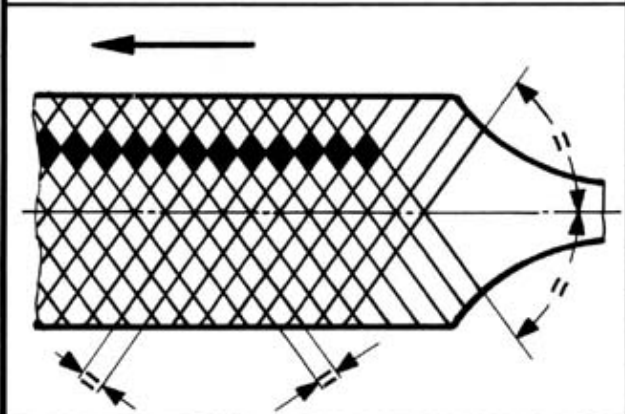



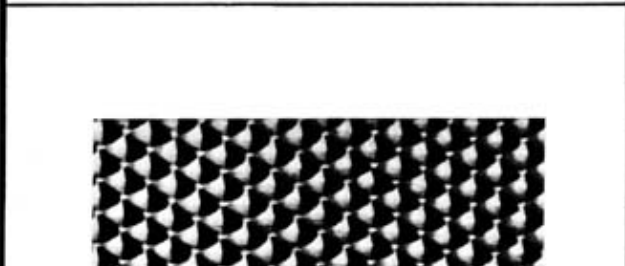





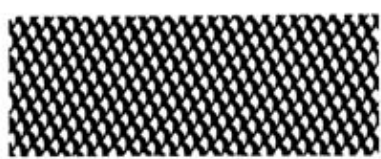
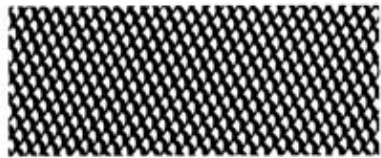
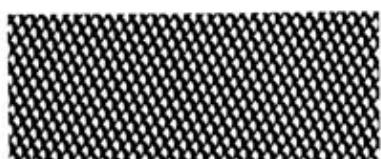
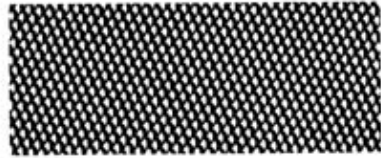

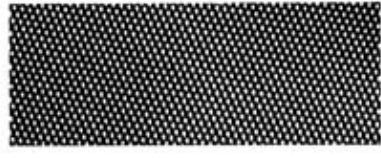





_____ 2.4



_____ 2.5



 1  2	_____ 3.1 1 _____ 2 _____
 3  4	_____ 3.2 3 _____ 4 _____
 5  6	_____ 3.3 5 _____ 6 _____
 □  341  ▽  342  □  343  ▷  344  ○  345  ▷  346  ◇  347	_____ 3.4 341 _____ 342 _____ 343 _____ 344 _____ 345 _____ 346 _____ 347 _____

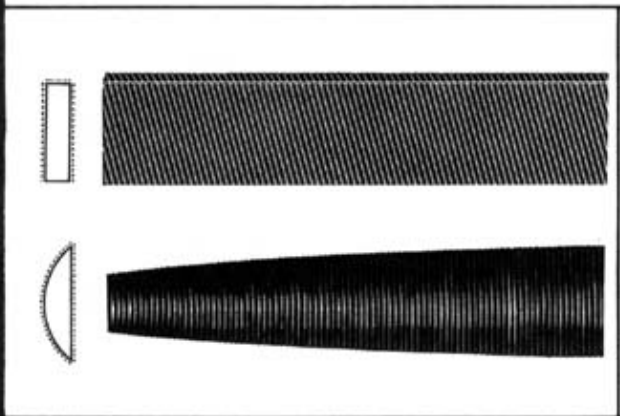

_____ 4.1

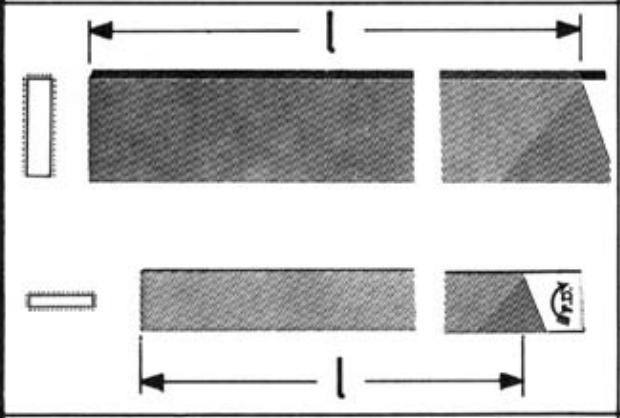

_____ 4.2

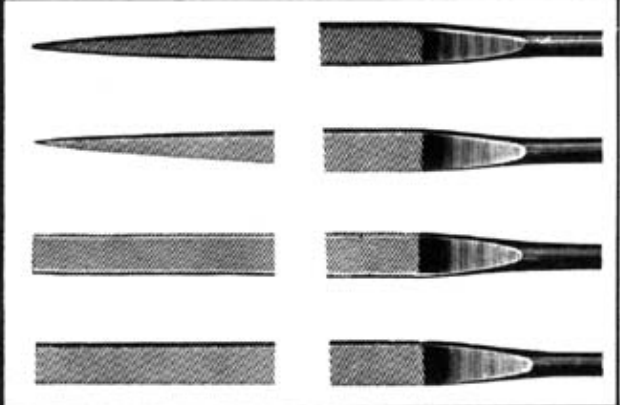

_____ 4.3

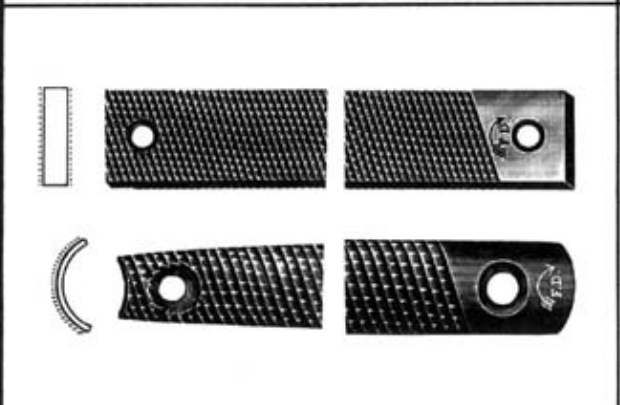

_____ 4.4



_____ 4.5



	<p>5.1</p> <hr/>
	<p>5.2</p> <hr/>
	<p>5.3</p> <hr/>
	<p>5.4</p> <hr/>
<p>39</p>	<p>5.5</p> <hr/>

8. Drilling, Counterboring, Countersinking – Bohren, Reiben

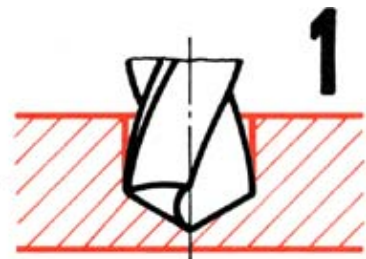

1

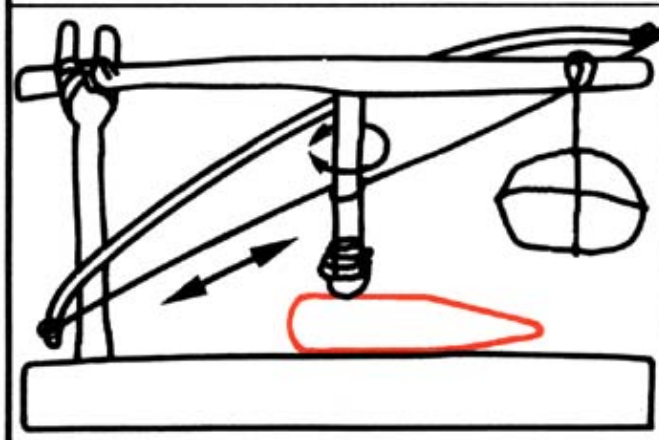

1.1

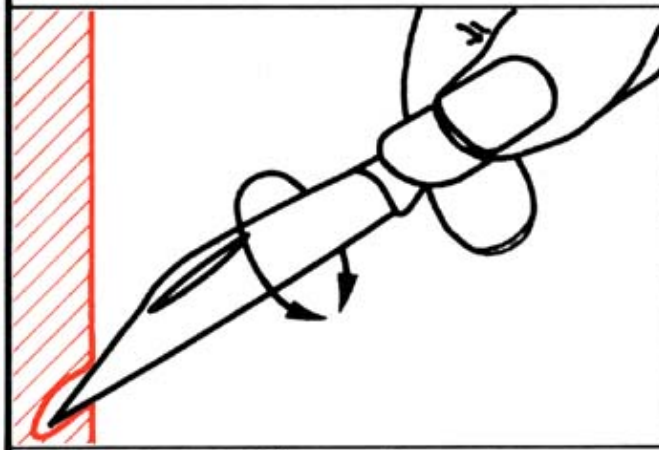

1.2

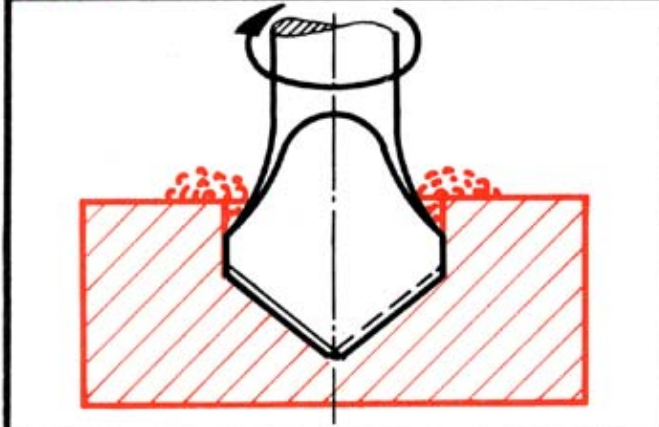

1.3

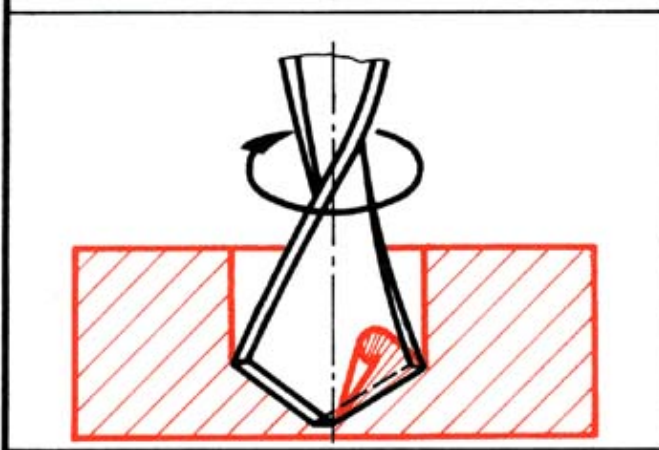

1.4



1.5

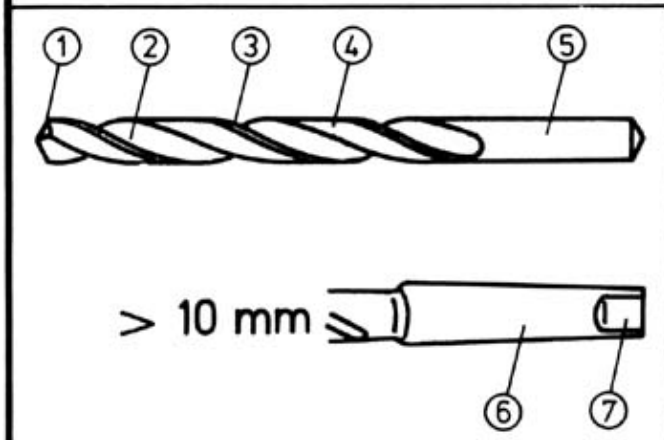
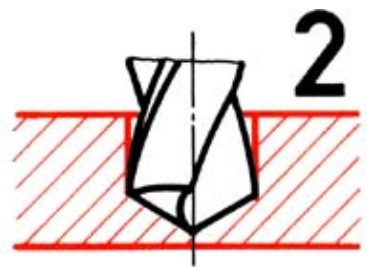

2.1

① _____
 ② _____
 ③ _____
 ④ _____
 ⑤ _____
 ⑥ _____
 ⑦ _____

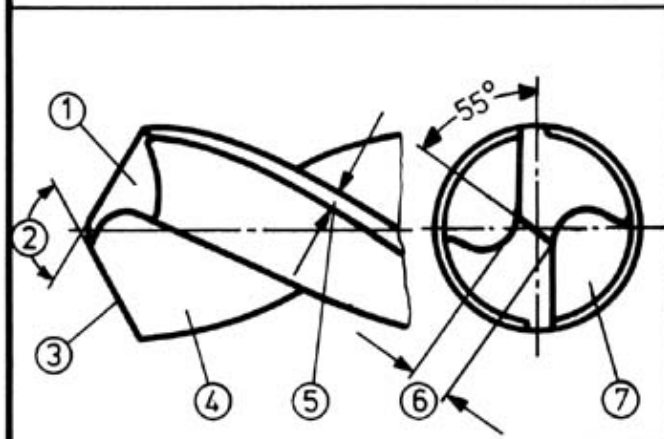

2.2

① _____
 ② $\sphericalangle \sigma$
 ③ _____
 ④ _____
 ⑤ _____
 ⑥ _____
 ⑦ _____

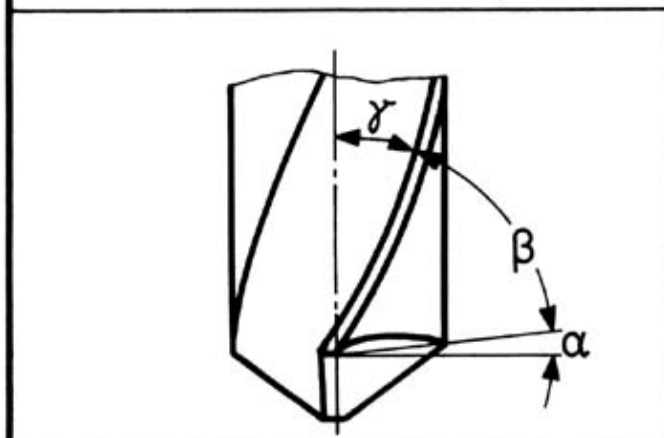

2.3

$\sphericalangle \alpha =$ _____
 $\sphericalangle \beta =$ _____
 $\sphericalangle \gamma =$ _____

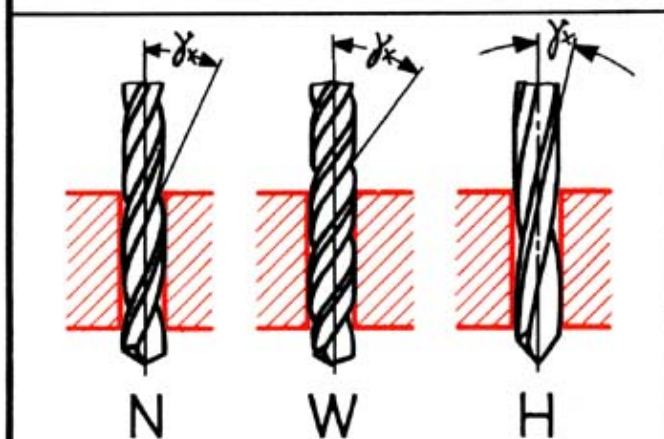

2.4

N - $\sphericalangle \gamma$ _____
 W - $\sphericalangle \gamma$ _____
 H - $\sphericalangle \gamma$ _____

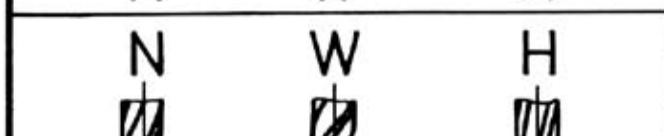

2.5

$\sphericalangle \sigma$ _____

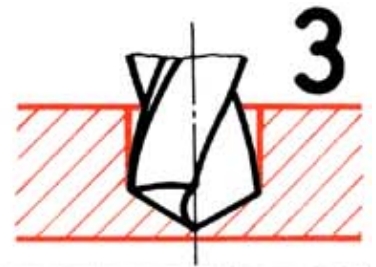

	<p>_____ 3.1</p> <p>①</p> <p>②</p>
	<p>_____ 3.2</p> <p>①</p> <p>②</p> <p>⚠</p>
	<p>_____ 3.3</p> <p>⚠</p>
	<p>_____ 3.4</p> <p>①</p> <p>②</p> <p>③</p>
	<p>_____ 3.5</p> <p>①</p> <p>②</p> <p>③</p>

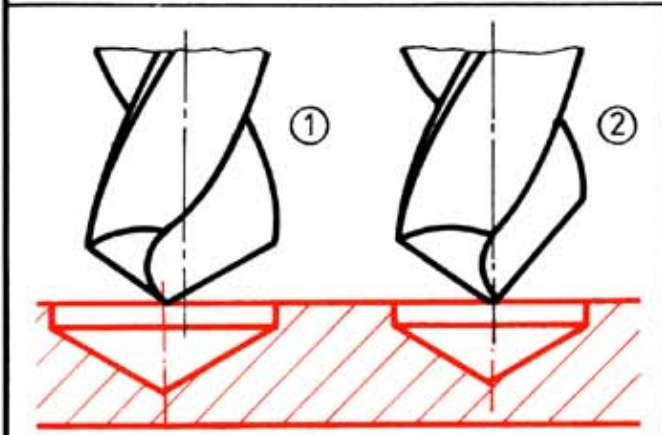
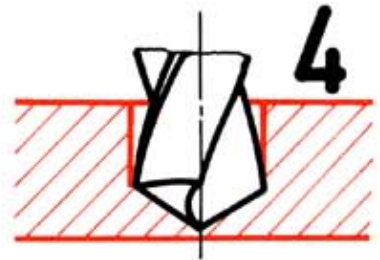

_____ 4.1

①

②

① + ② =

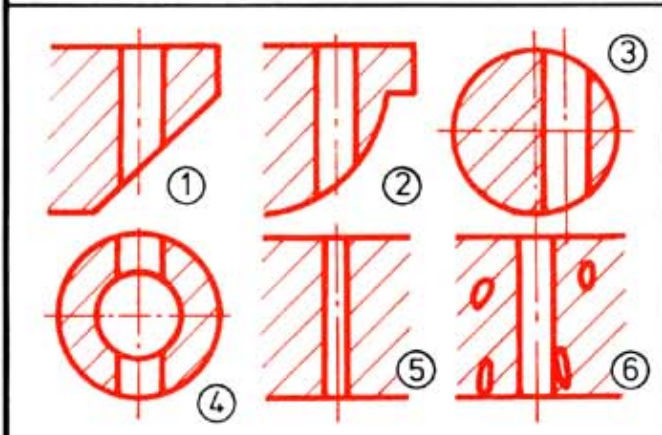

_____ 4.2

⚠

①

②

③

④

⑤

⑥

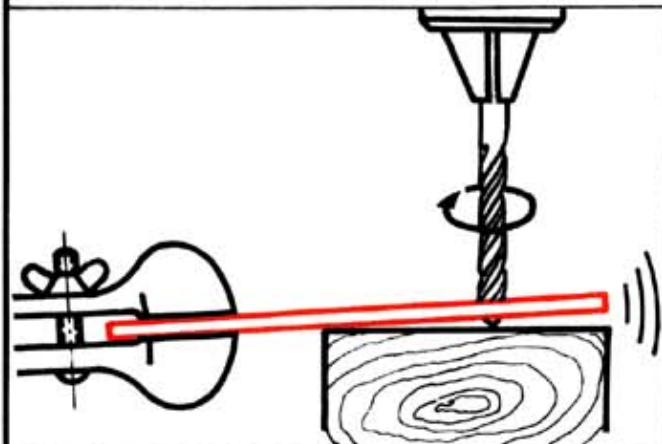

_____ 4.3

⚠

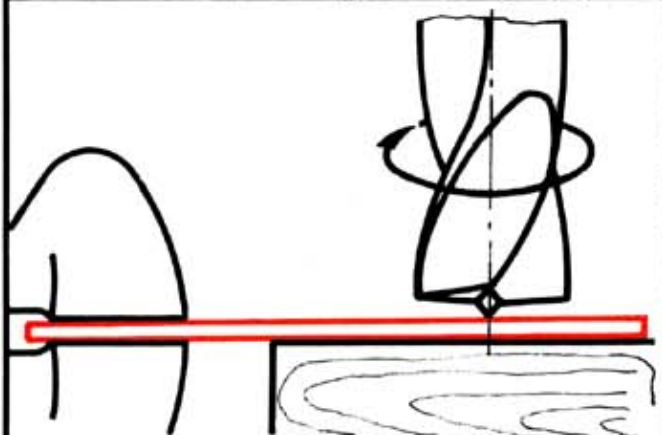

_____ 4.4

⚠



_____ 4.5



	<p>_____ 5.1</p> <p>① _____</p> <p>② _____</p>
--	--

	<p>_____ 5.2</p>
--	------------------

	<p>_____ 5.3</p> <p>① _____</p> <p>② _____</p>
--	--

	<p>_____ 5.4</p> <p>① _____</p> <p>② _____</p> <p>③ _____</p>
--	---

	<p>_____ 5.5</p>
--	------------------

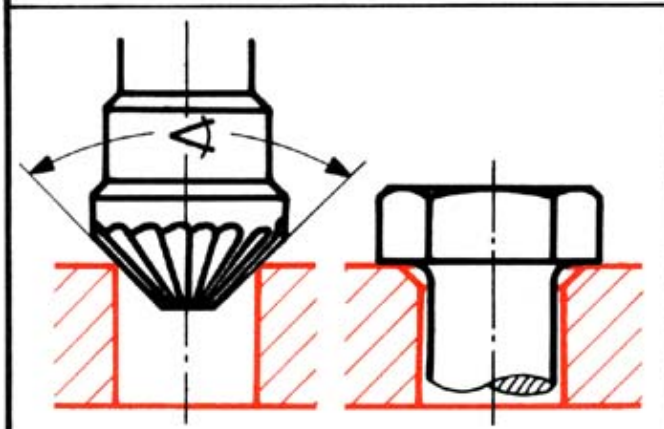
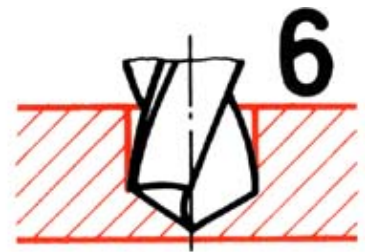

_____ 6.1
 $\alpha = 60^\circ, 75^\circ, 90^\circ, 120^\circ$

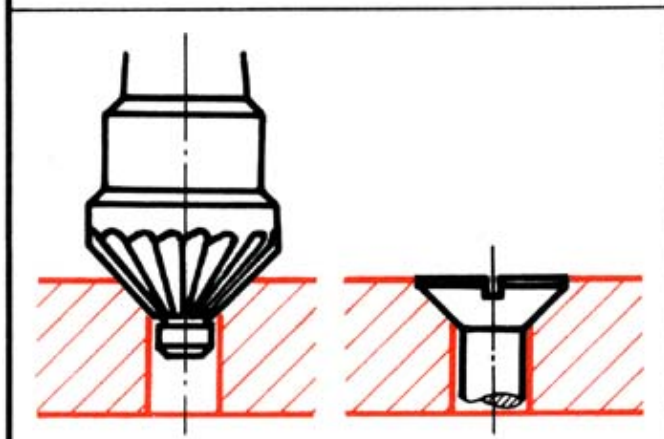

_____ 6.2

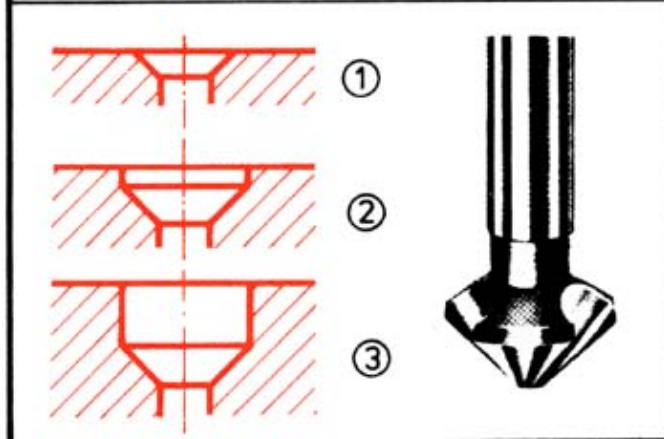

_____ 6.3
 ①
 ②
 ③

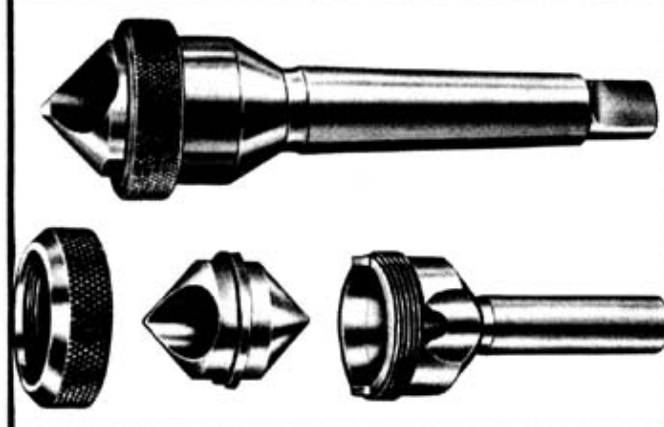

_____ 6.4



_____ 6.5

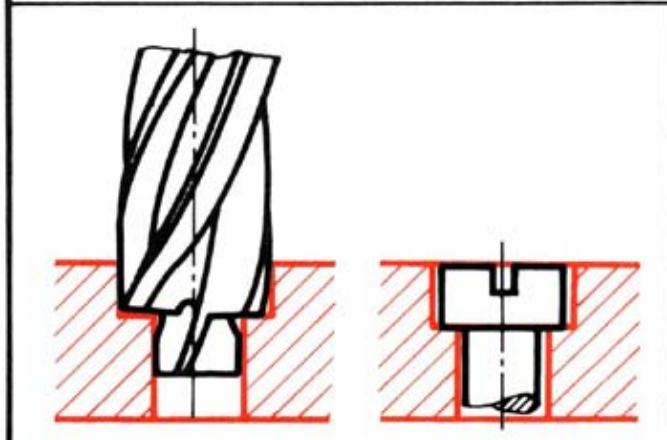

7.1

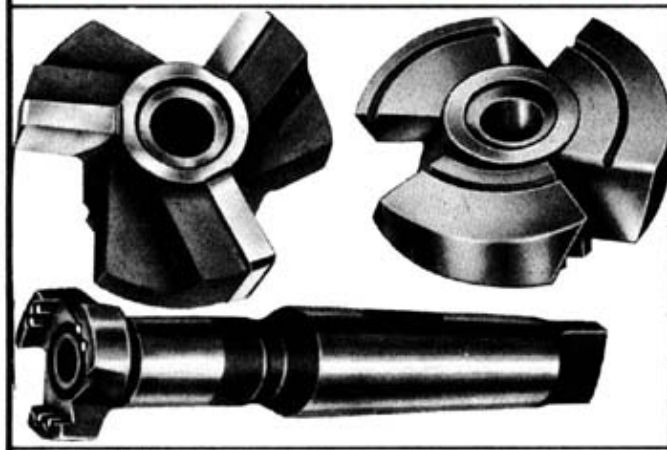

7.2

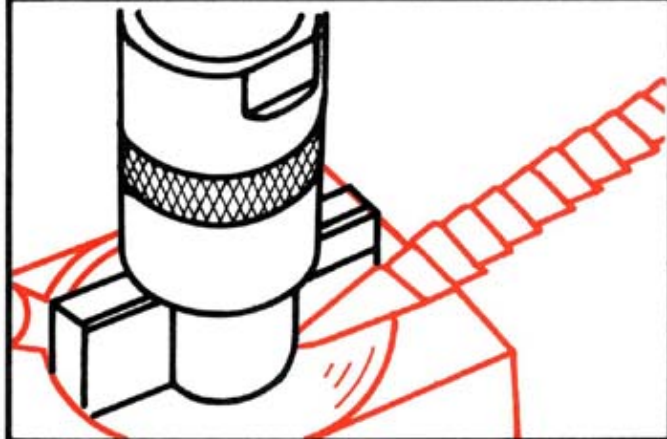

7.3

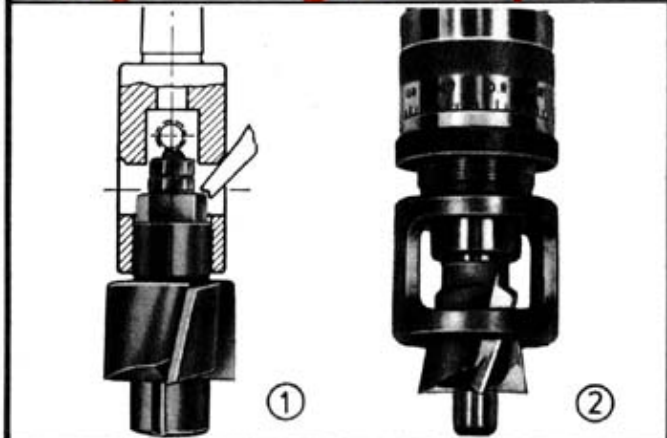

7.4

①

②



7.5

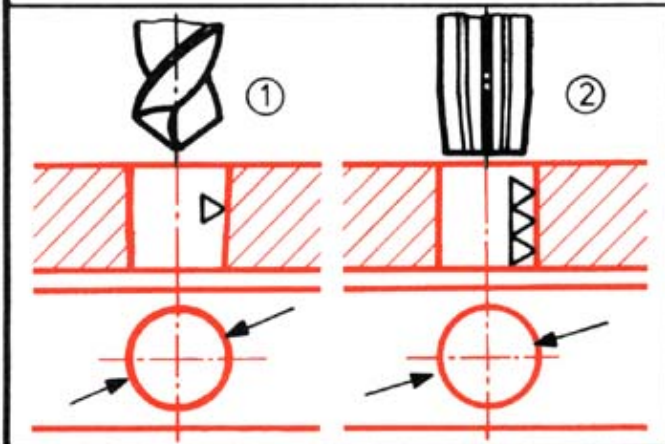

_____ 8.1

①

②

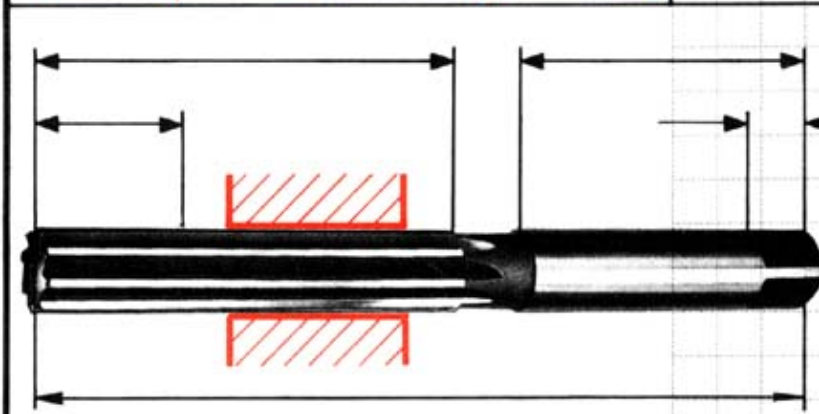

8.2

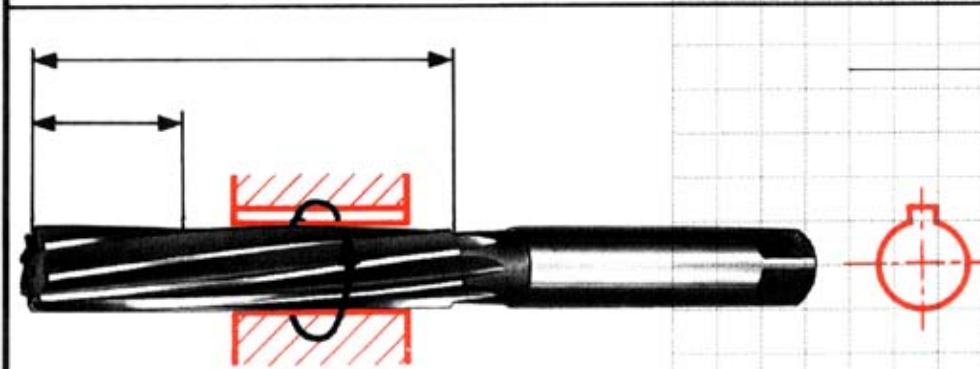

8.3

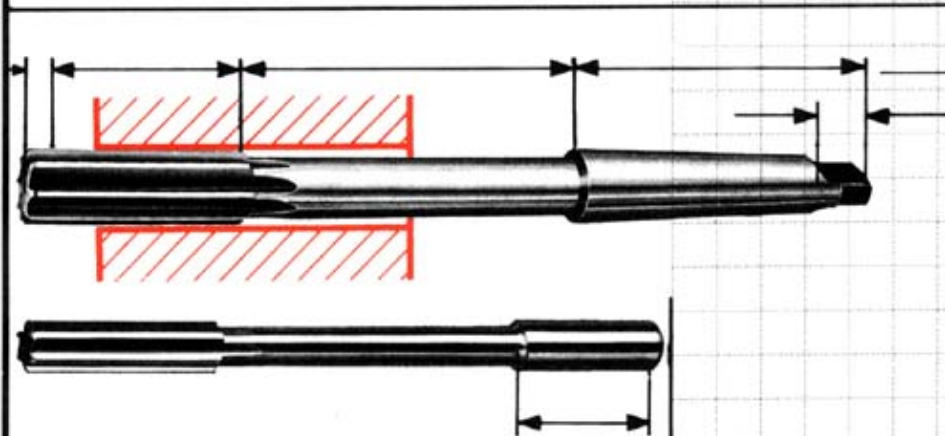

8.4



8.5

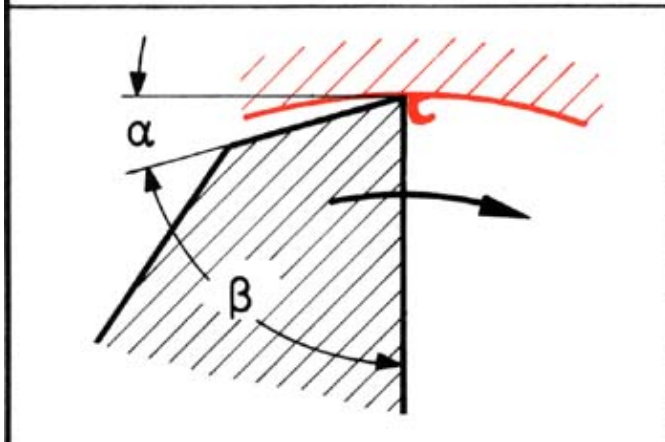

9.1

- ▷ α =
- ▷ β =
- ▷ γ =

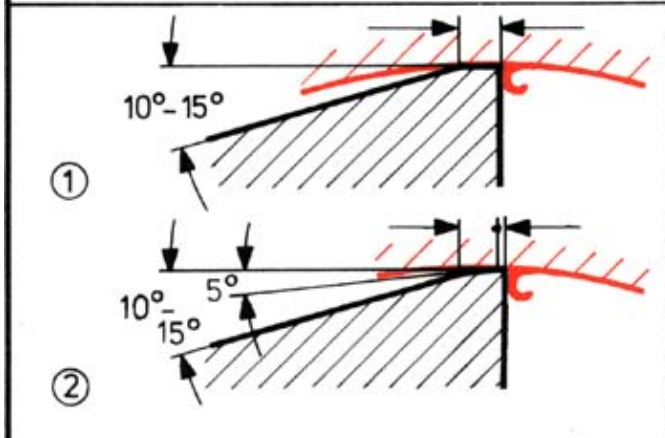

9.2

①

②

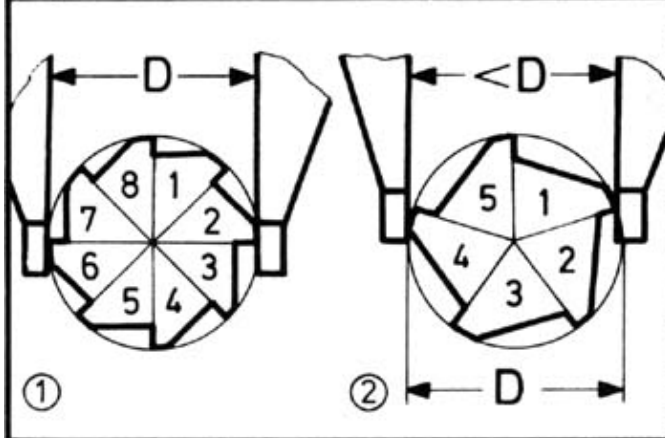

9.3



①

②

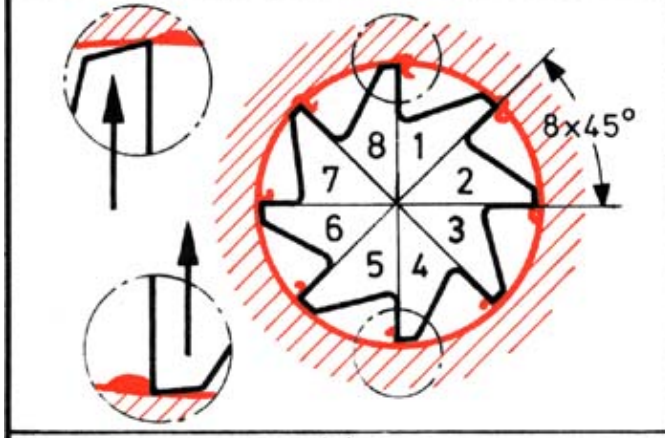

9.4



9.5

10

 	<p>_____ 10.1</p>
	<p>_____ 10.2</p>
	<p>_____ 10.31</p>
<p>① ②</p>	<p>_____ 10.32</p> <p>①</p> <p>②</p>
 	<p>_____ 10.4</p> <p>①</p> <p>②</p>
	<p>_____ 10.5</p> <p>①</p>

9. Turning – Drehen

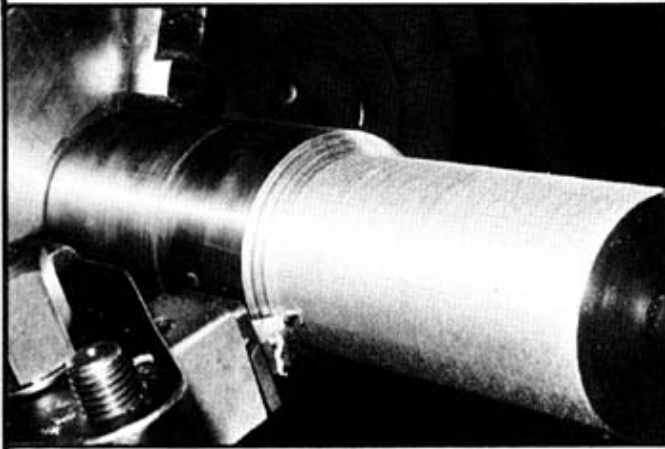

1.1

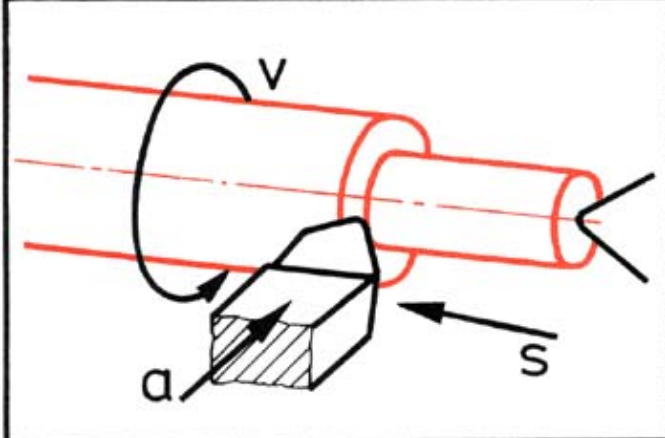

1.2

v -
a -
s -

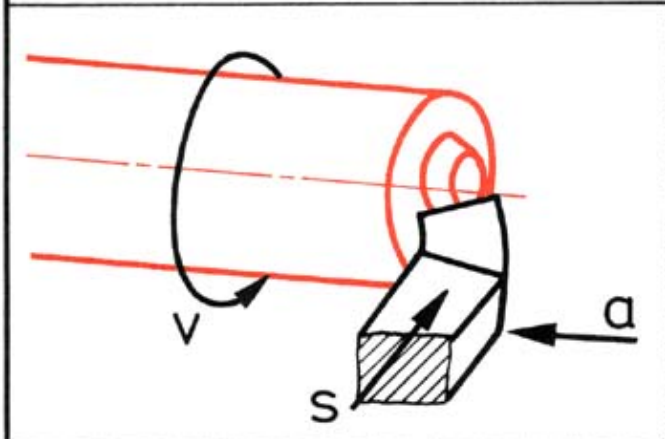

1.3

v -
a -
s -

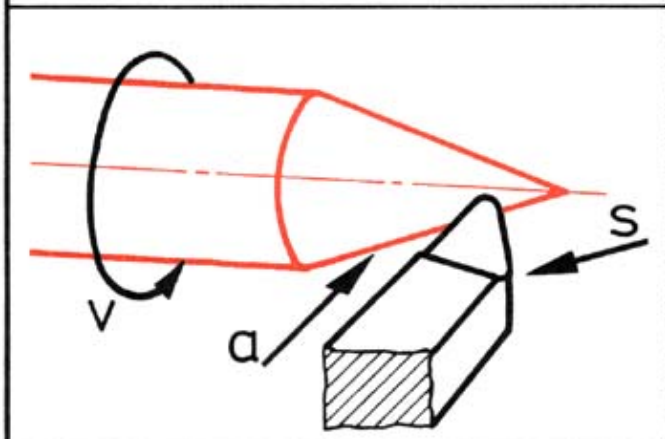

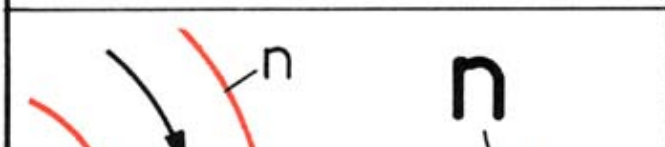

1.4

v -
a -
s -

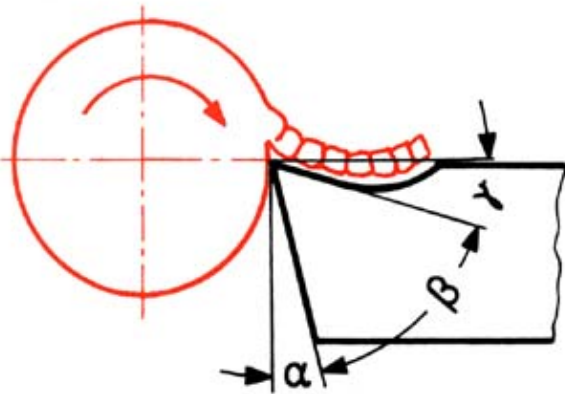
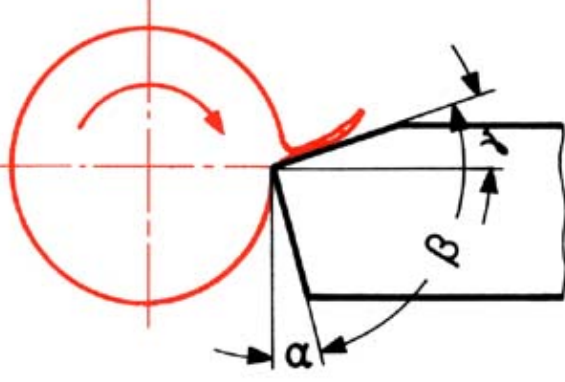
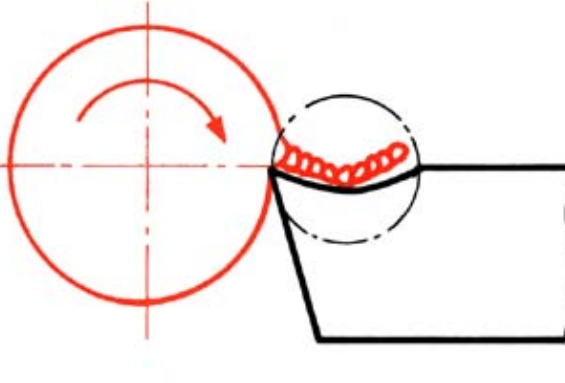
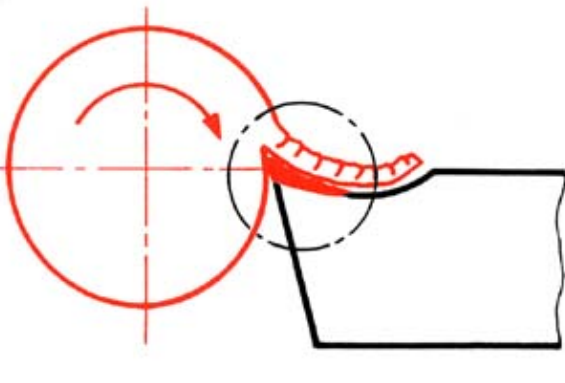

1.5

	<p style="text-align: right;">2.1</p> <hr style="width: 100%;"/> <p> $\Delta \alpha =$ $\Delta \beta =$ $\Delta \gamma =$ </p>
	<p style="text-align: right;">2.2</p> <hr style="width: 100%;"/>
	<p style="text-align: right;">2.3</p> <hr style="width: 100%;"/>
	<p style="text-align: right;">2.4</p> <hr style="width: 100%;"/>
<p>53</p> 	<p style="text-align: right;">2.5</p> <hr style="width: 100%;"/> <p style="text-align: center;">① ①</p>

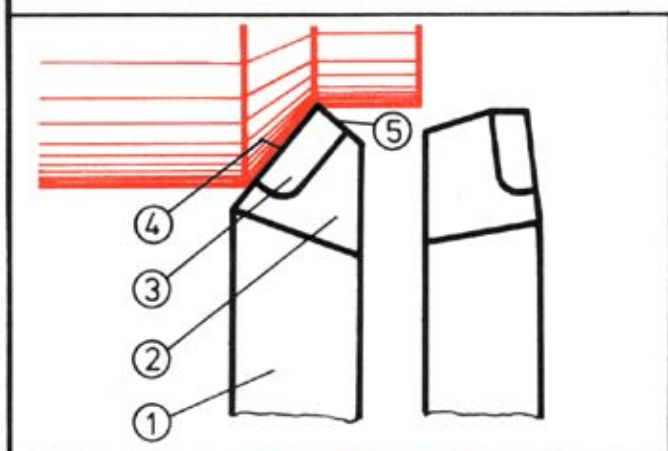

3.1

①
②
③
④
⑤

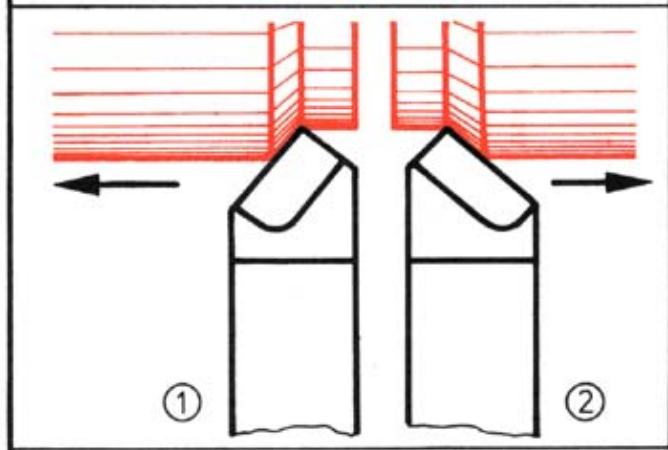

3.2

①
②

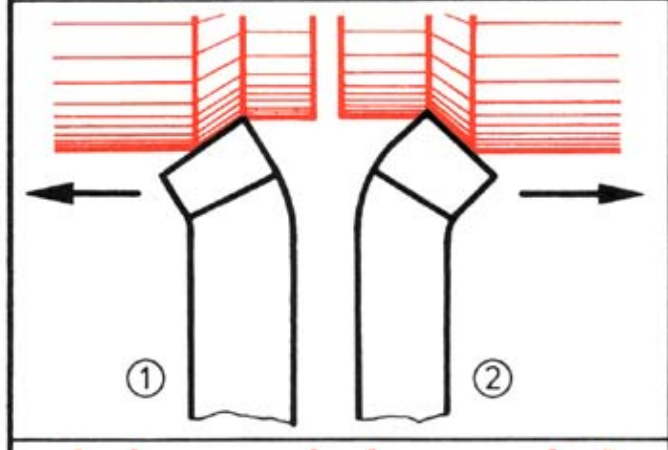

3.3

①
②

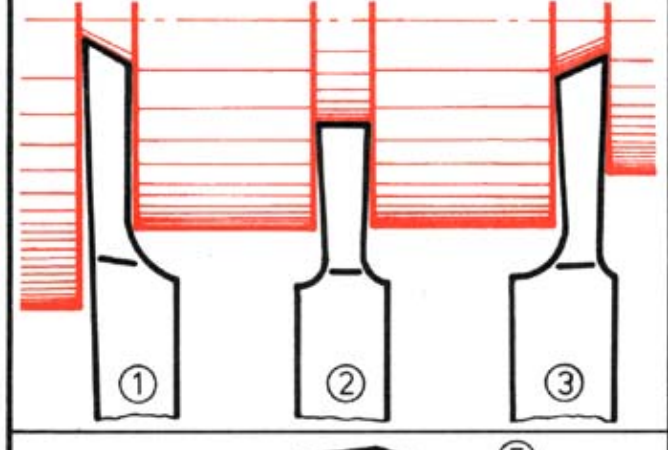

3.4

①
②
③



3.5

①

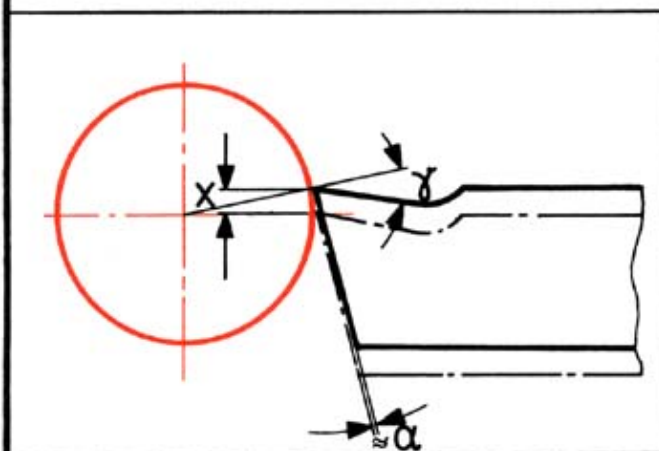

_____ 4.1

$\sphericalangle \alpha =$
 $\sphericalangle \beta =$
 $\sphericalangle \gamma =$

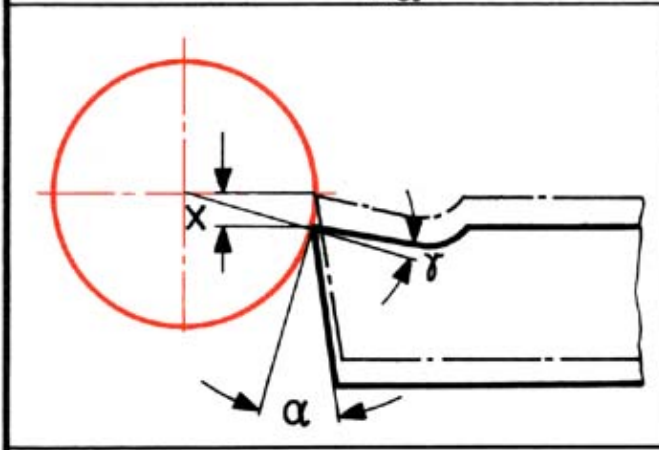

_____ 4.2

$\sphericalangle \alpha =$
 $\sphericalangle \beta =$
 $\sphericalangle \gamma =$

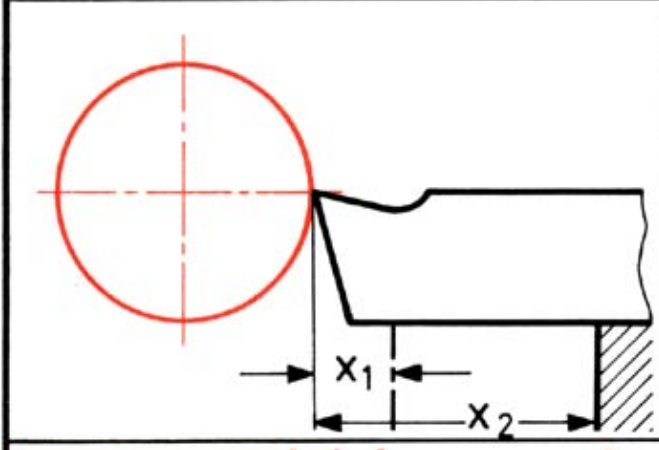

_____ 4.3

$x_1 =$
 $x_2 =$

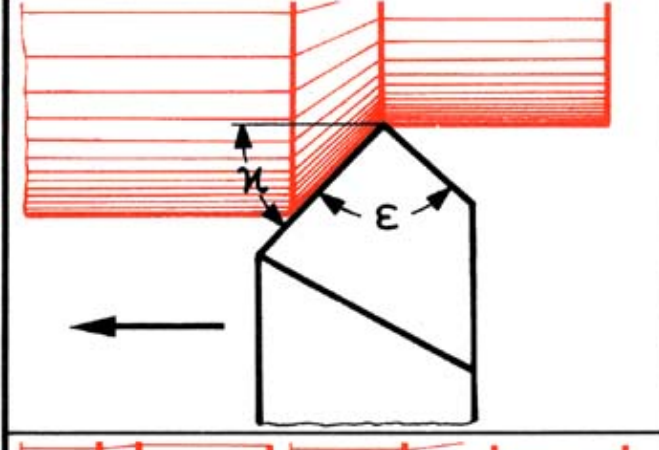

_____ 4.4

$\epsilon =$
 $\chi =$



_____ 4.5

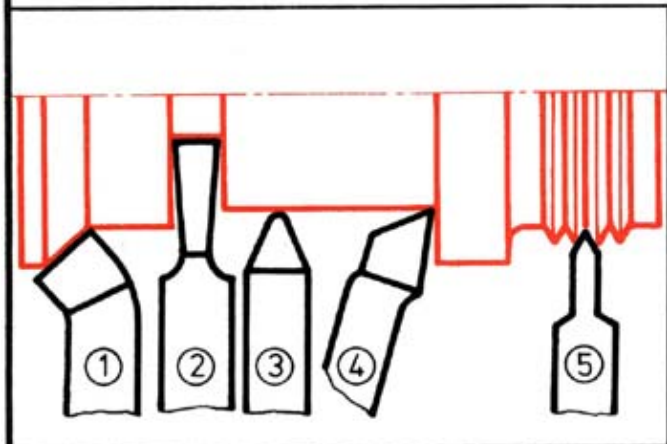

5.1

①
②
③
④
⑤

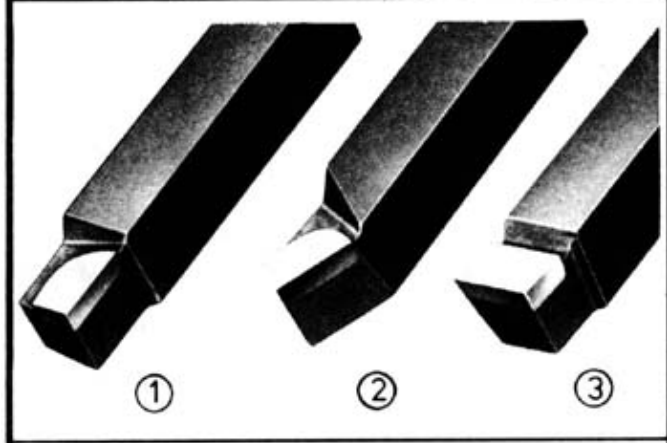

5.2

①
②
③

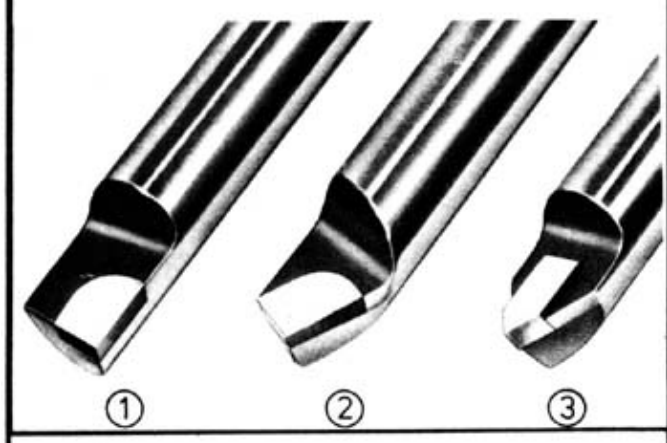

5.3



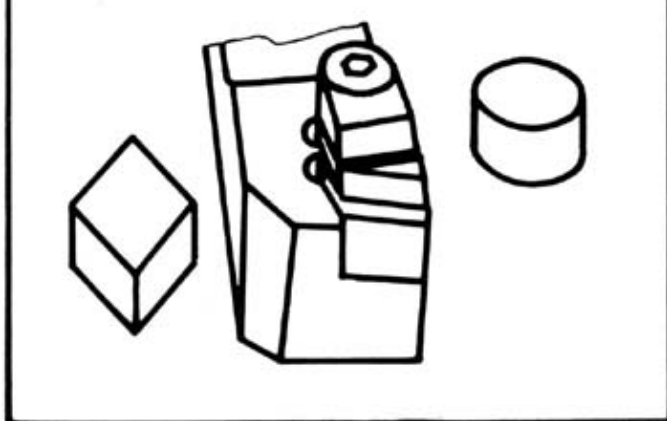



①
②
③

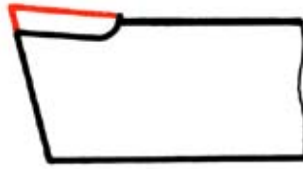

5.4

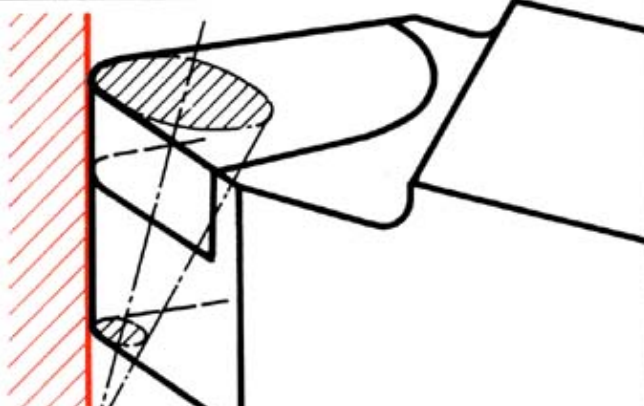

5.5

 <p>①</p>  <p>②</p>	<p>_____ 5.1</p>
 <p>③</p>  <p>④</p>	<p>_____ 5.2</p>
 <p>⑤</p>  <p>⑥</p>	<p>_____ 5.3</p>
	<p>_____ 5.4</p>
	<p>_____ 5.5</p>

6

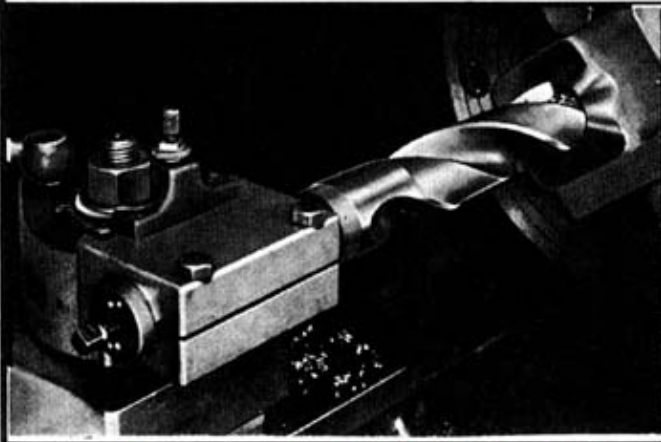

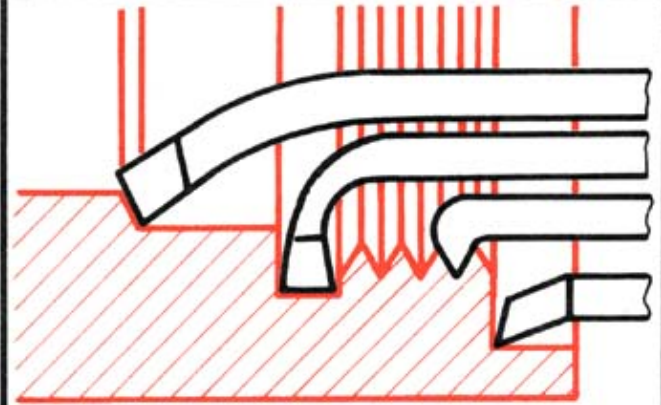

6.1

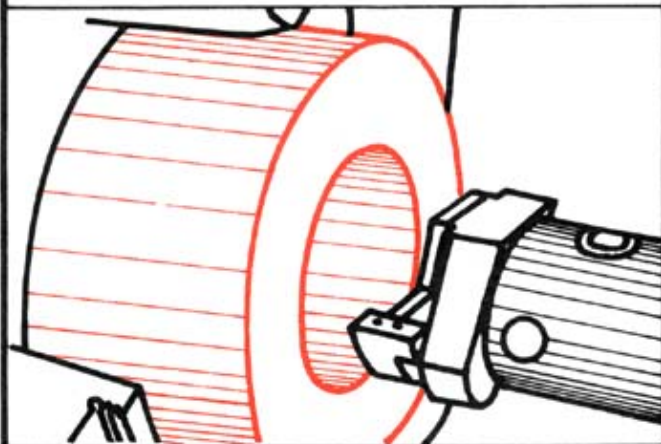

6.2

- ①
- ②
- ③
- ④



6.3

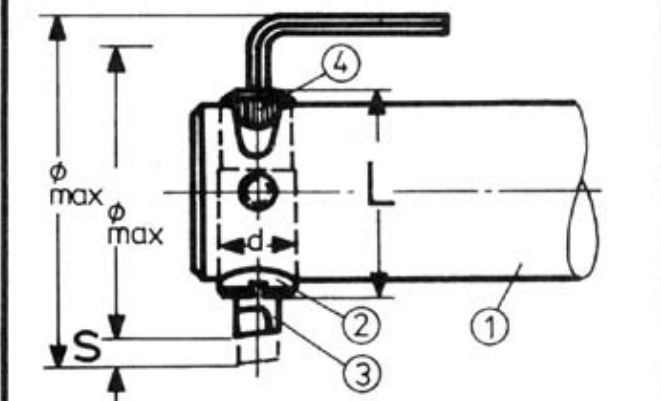

6.4

- ①
- ②
- ③
- ④

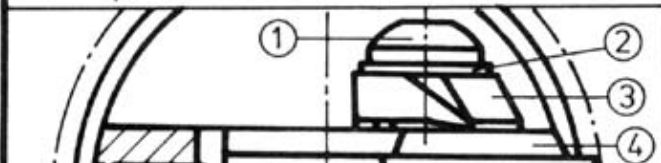

6.5

- ①
- ②

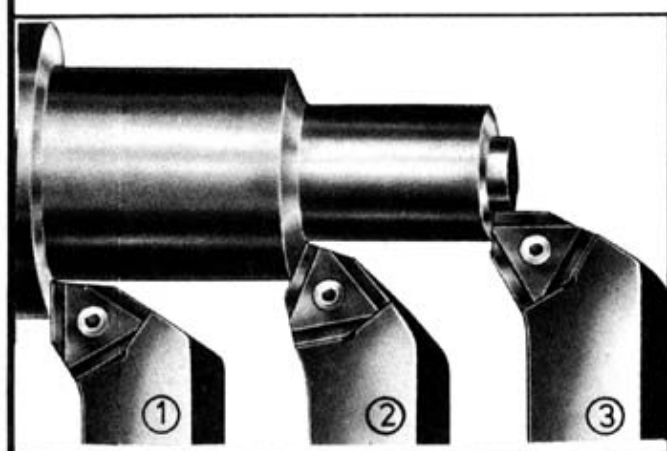

7.1

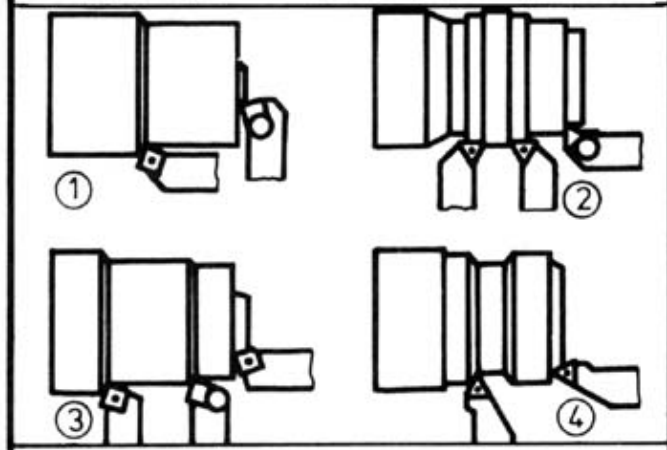

7.2

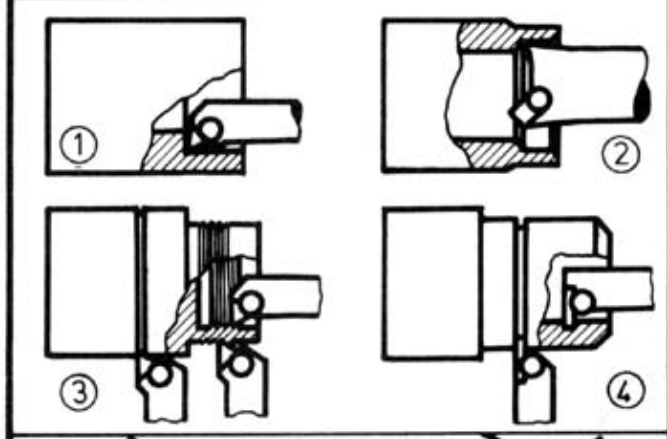

7.3

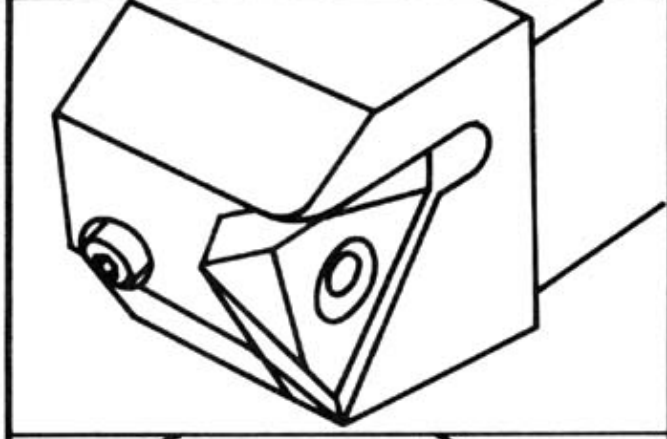

7.4



7.5

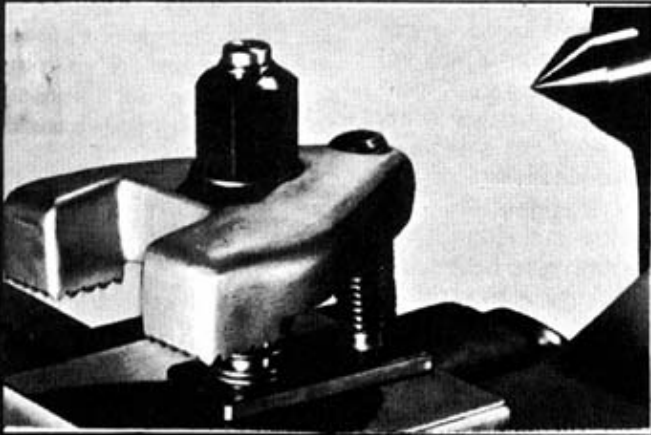

8.1

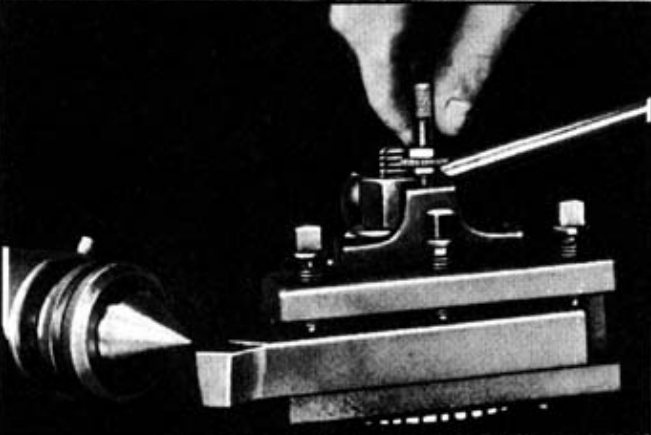

8.2

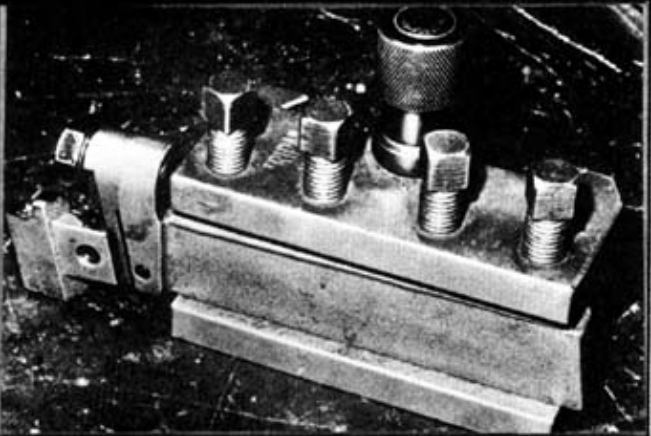

8.3





8.4



8.5

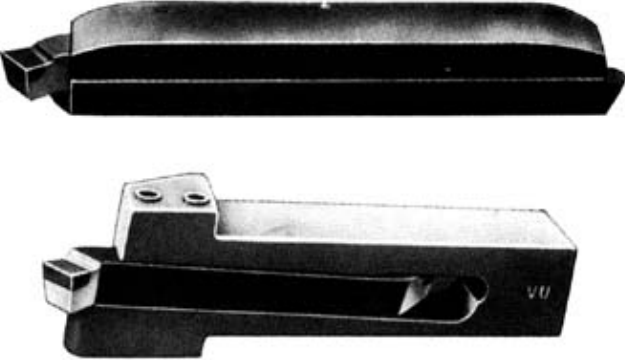
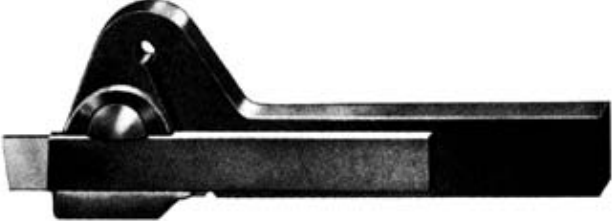
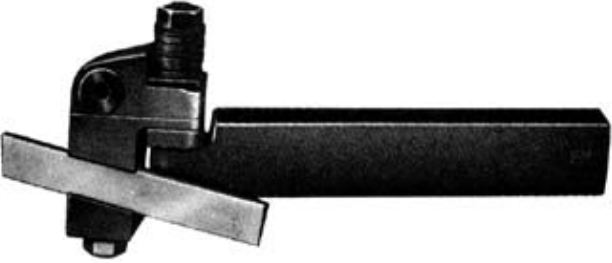
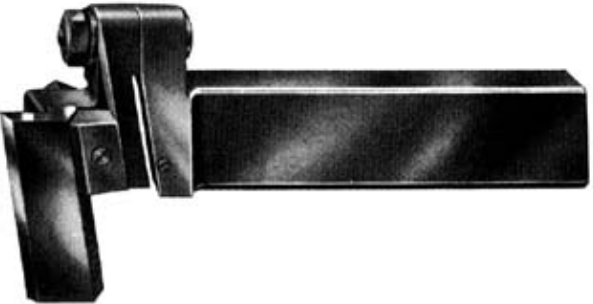

9

	<p>9.1</p>
	<p>9.2</p>
	<p>9.3</p>
	<p>9.4</p>
<p>61</p> 	<p>9.5</p>

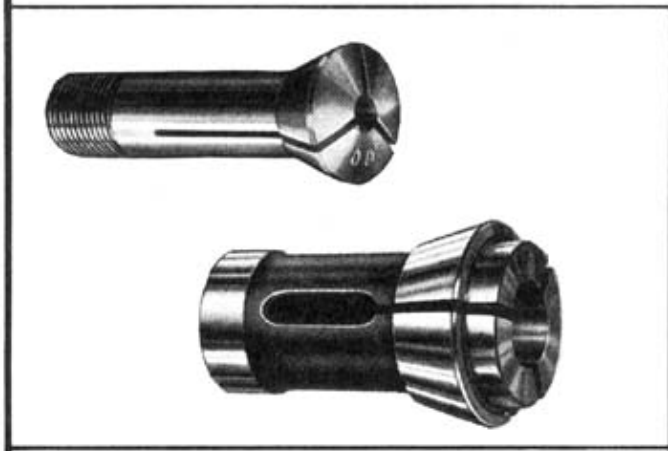

10.1

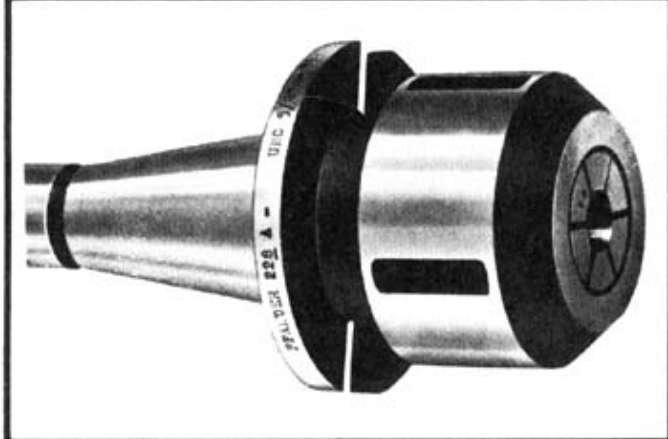

10.2

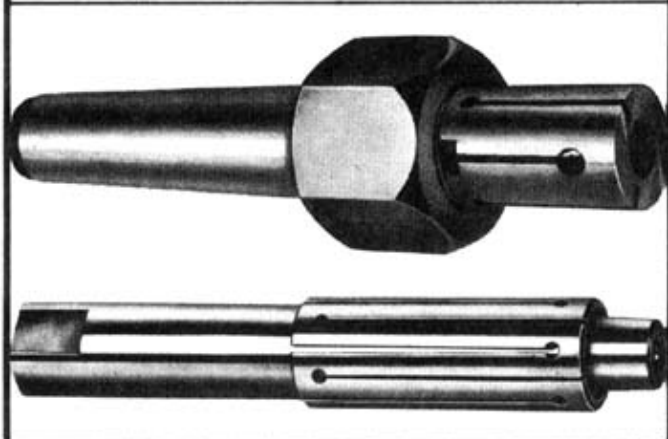

10.3

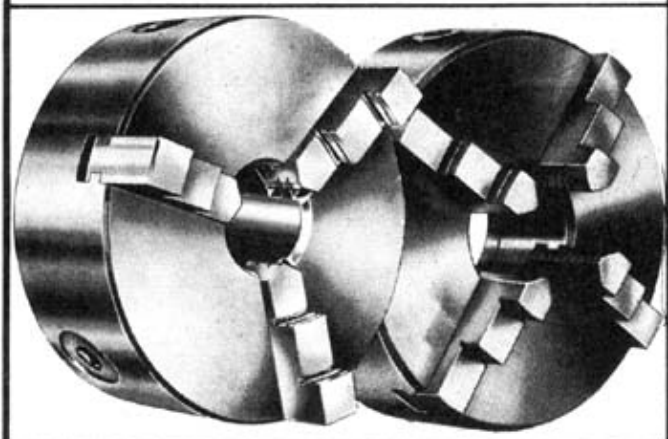

10.4



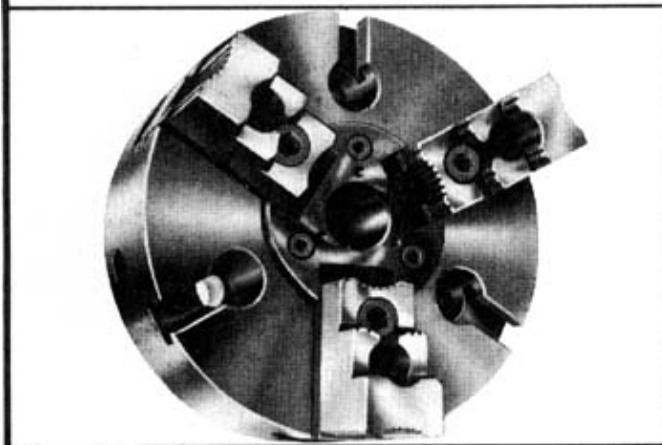

10.5

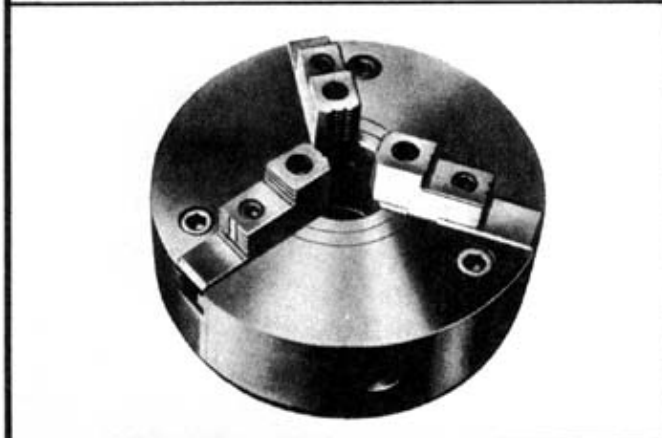

10.1

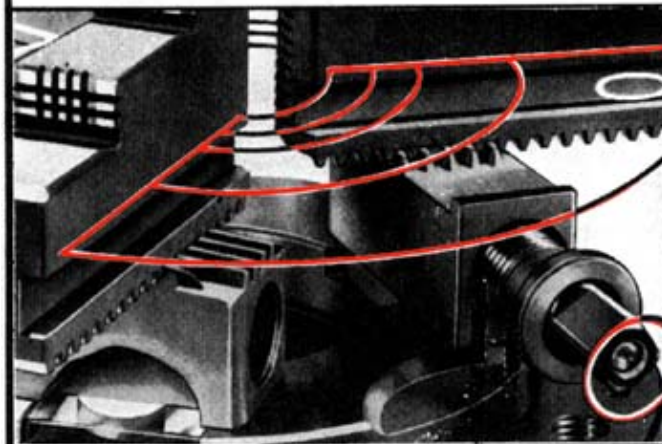

10.2



10.3





10.4



10.5

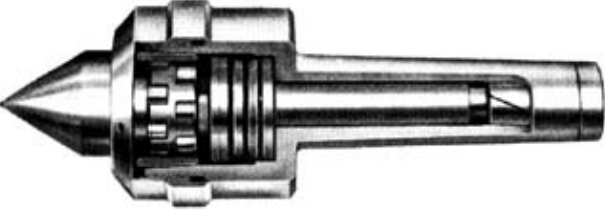
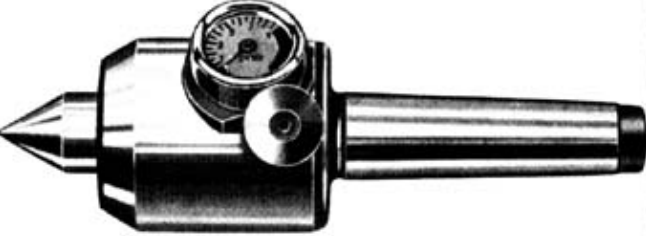
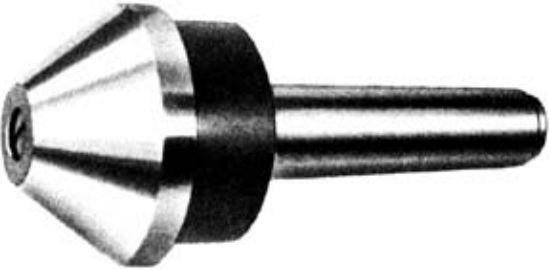
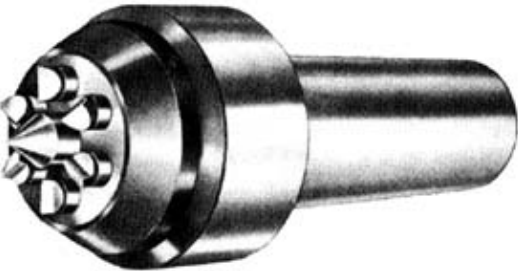

	<p>_____ 11.1</p>
	<p>_____ 11.2</p>
	<p>_____ 11.3</p>
	<p>_____ 11.4</p>
	<p>_____ 11.5</p>

10. Shaping – Hobeln

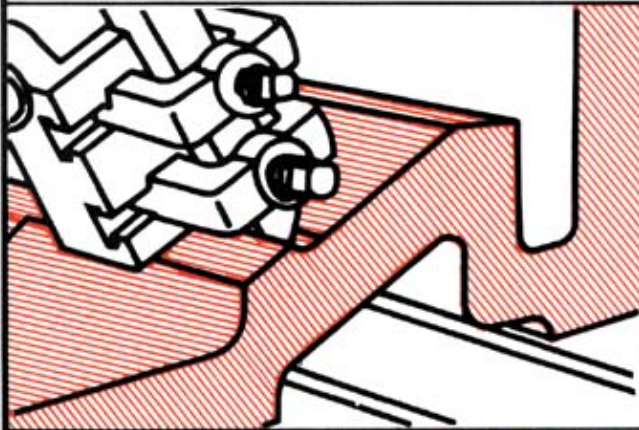
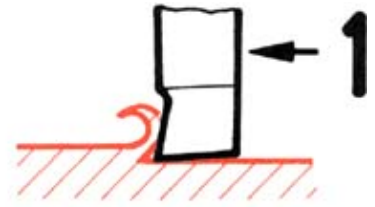

1.1

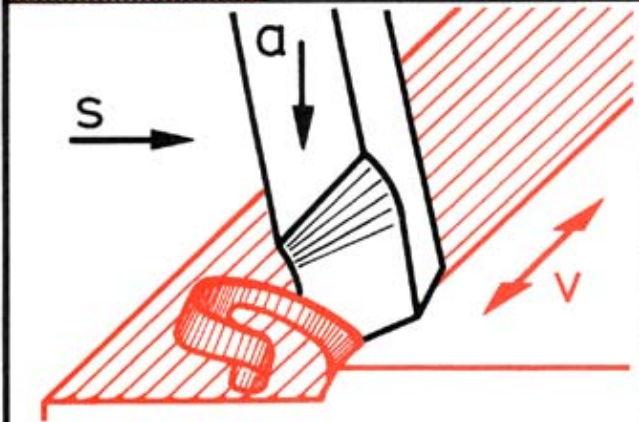

1.2

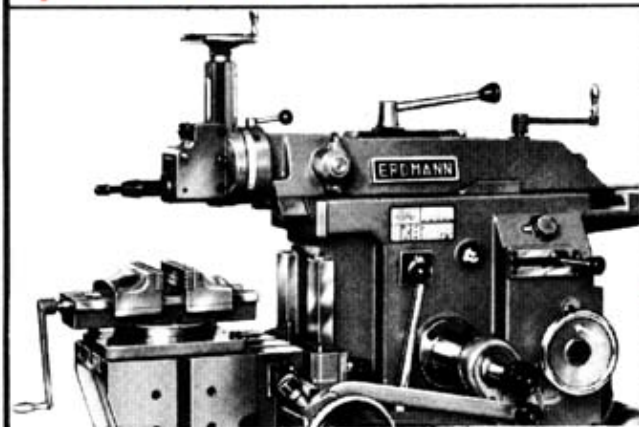

1.3

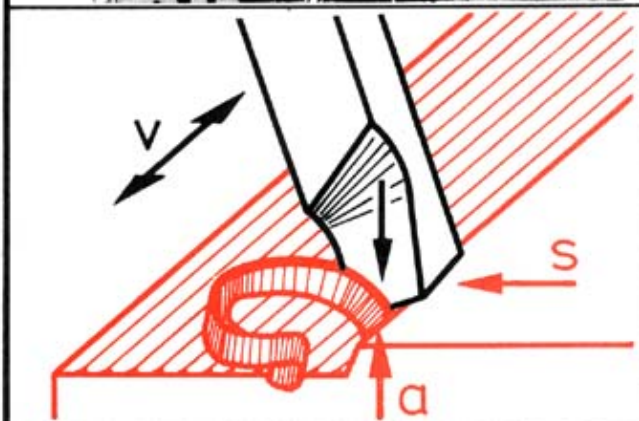

1.4

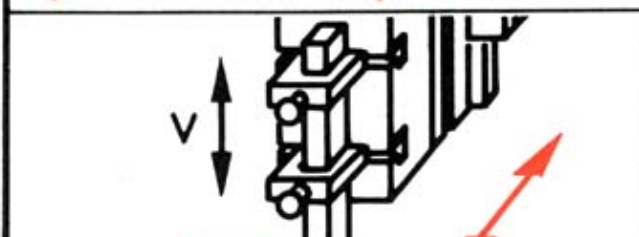

1.5

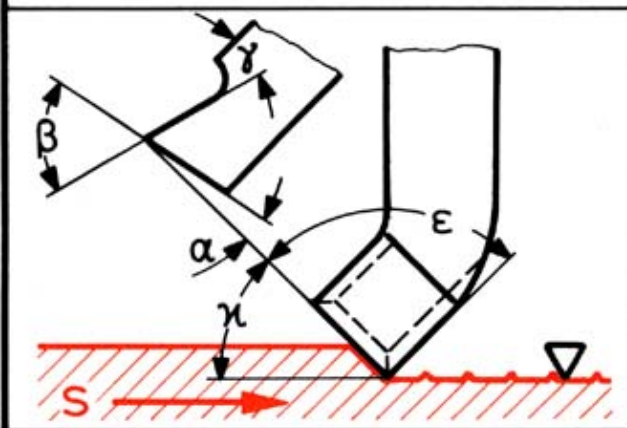
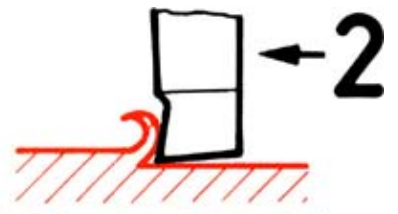

_____ 2.1

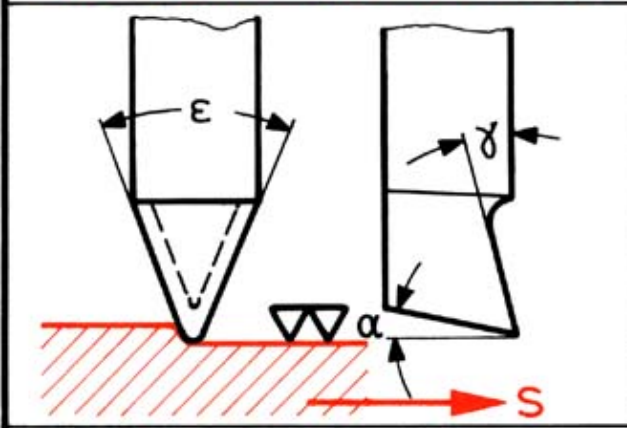

_____ 2.2

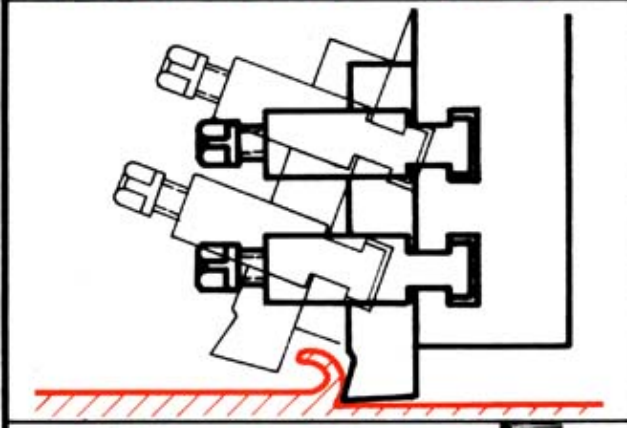

_____ 2.3

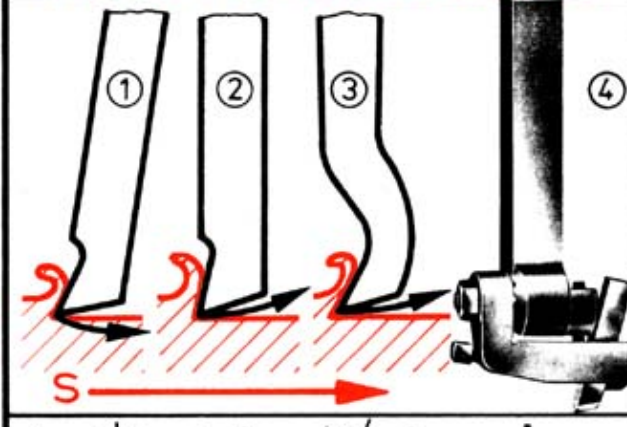

_____ 2.4

①
②
③
④



_____ 2.5

①
②

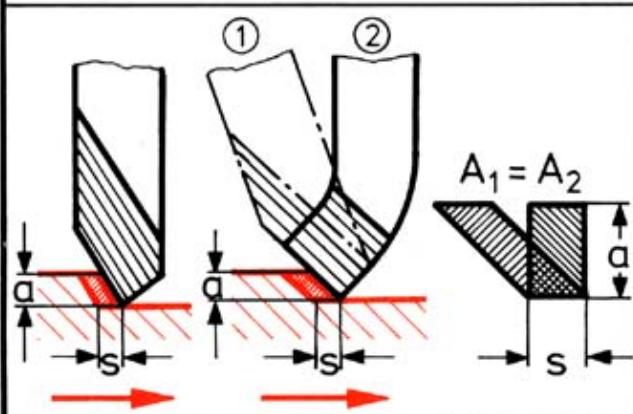
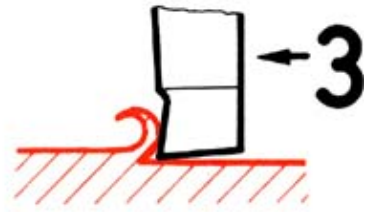

_____ 3.1

①

②

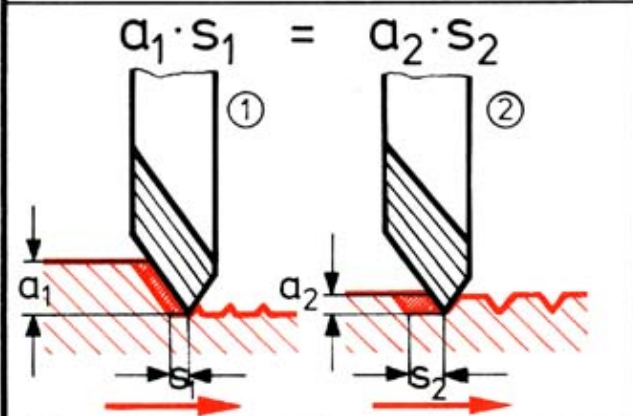

_____ 3.2

①

②

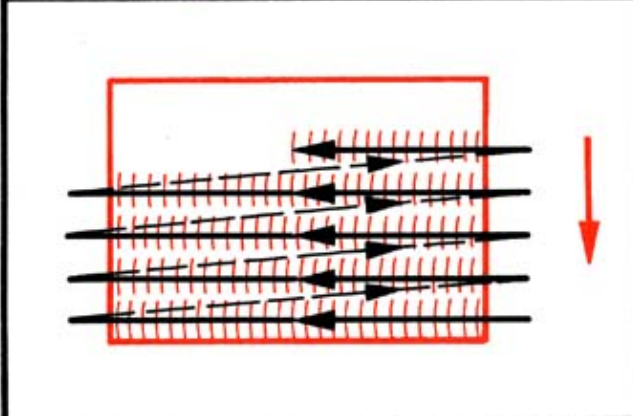

_____ 3.3

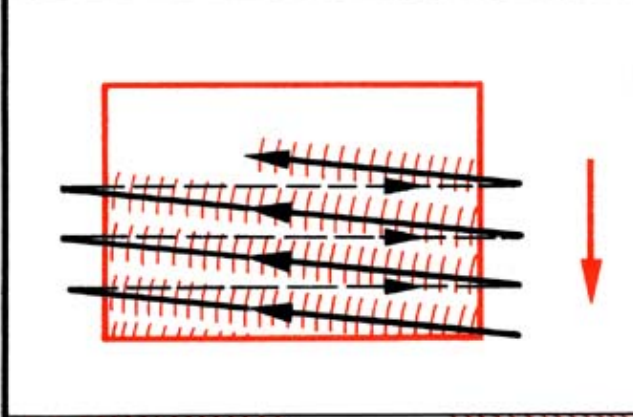

_____ 3.4

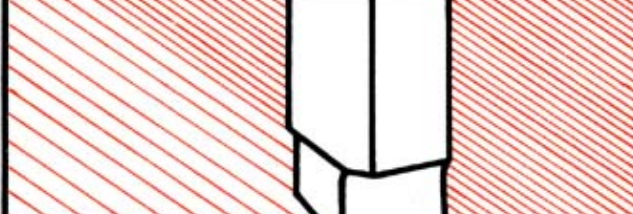

_____ 3.5

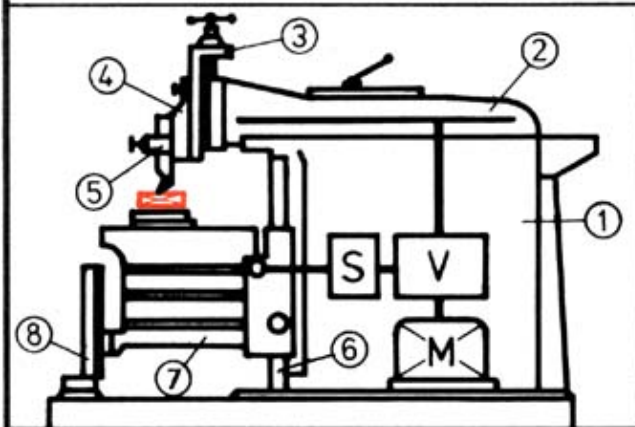
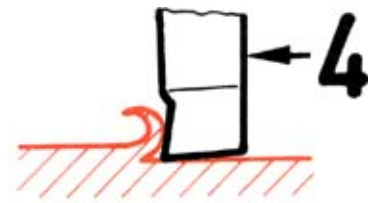

_____ 4.1

①	⑦
②	⑧
③	M
④	V
⑤	S
⑥	

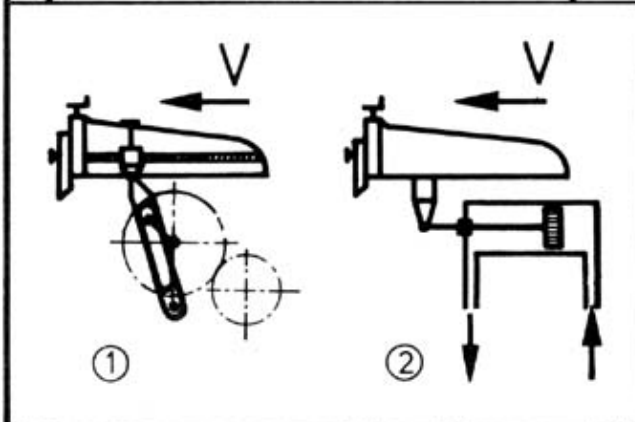

_____ 4.2

①

②

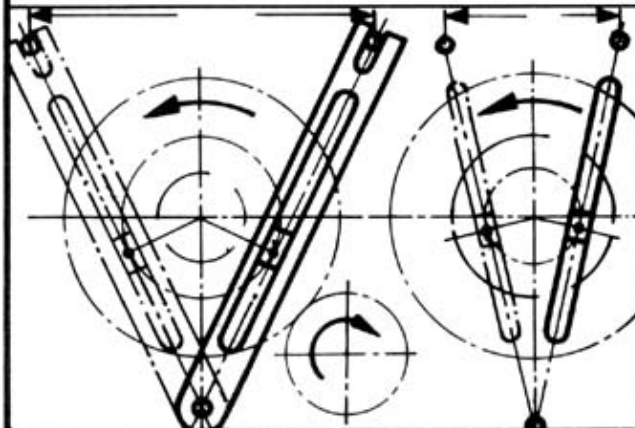

_____ 4.3

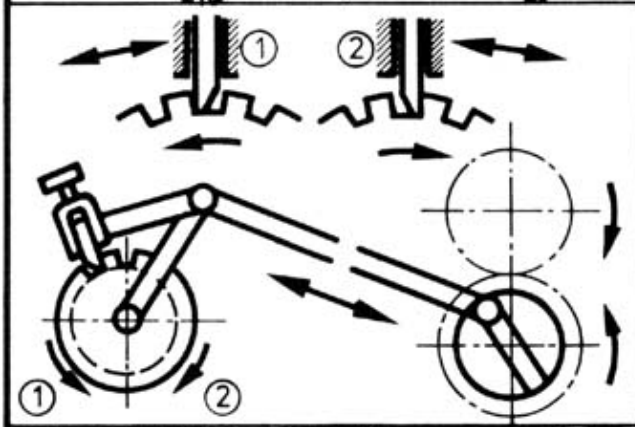

_____ 4.4

①

②



_____ 4.5

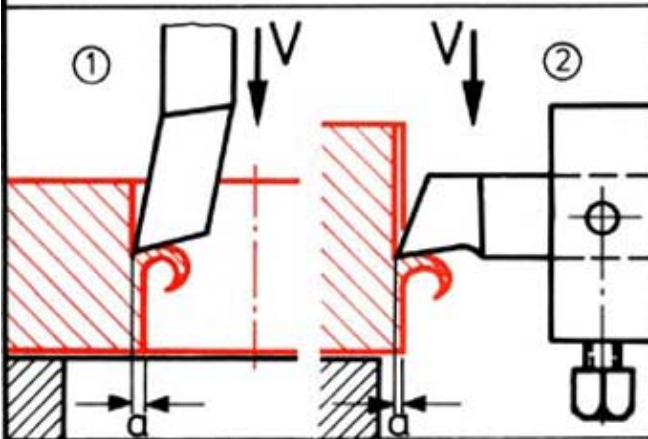
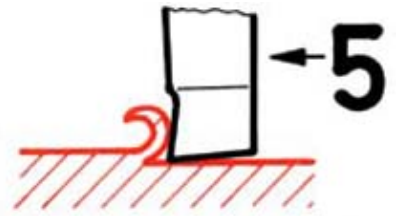

_____ 5.1

①

②

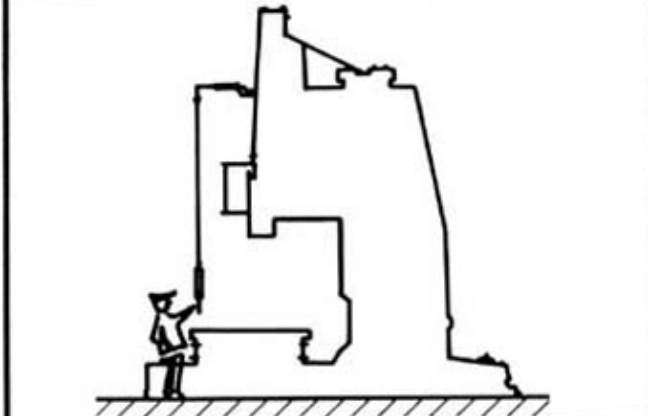

_____ 5.2

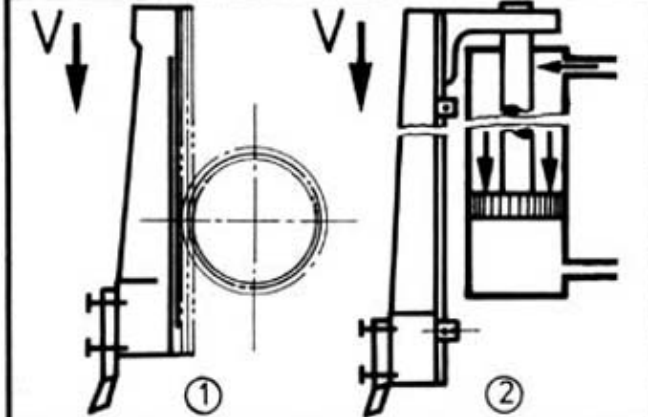

_____ 5.3

①

②

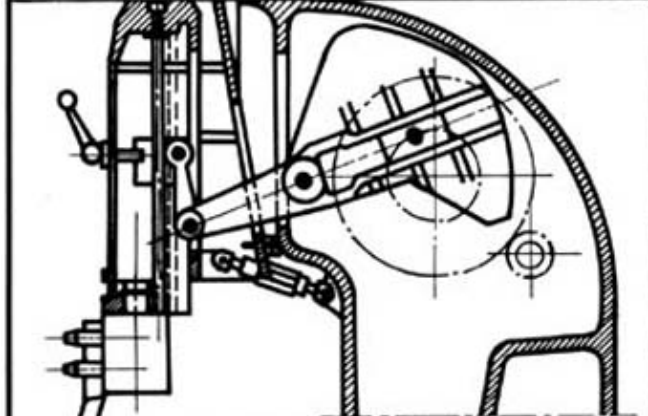

_____ 5.4



_____ 5.5

11. Thread cutting – Gewinde schneiden



	<p style="text-align: right;">1.1</p> <p>d =</p> <p>d · π =</p> <p>P =</p> <p>∠ α =</p>
--	---

	<p style="text-align: right;">DIN(M) 1.2</p> <p>d =</p> <p>P =</p> <p>$t_1 = 0,6495 \cdot P \approx 0,1 \cdot d =$</p> <p>$d_2 = d - 0,6495 \cdot P =$</p> <p>$d_1 = d - 1,299 \cdot P \approx 0,8 \cdot d =$</p> <p>∠ 60° =</p>
--	---

	<p style="text-align: right;">ISO(M) 1.3</p> <p>d = D =</p> <p>P =</p> <p>d₃ =</p> <p>D₁ =</p> <p>d₂ = D₂ =</p> <p>∠ 60° =</p>
--	--

	<p style="text-align: right;">Whitworth (") 1.4</p> <p>d = D =</p> <p>P =</p> <p>d₁ =</p> <p>d₂ =</p> <p>∠ 55° =</p> <p>z =</p>
--	---

	<p style="text-align: right;">1.5</p> <p>1" =</p> <p>R 1" =</p> <p>1/2" =</p> <p>R 1/2" =</p>
--	---



<p>M 16 M 16 x 1</p> <p>① ②</p> <p>1" (W 24 x 1/10")</p>	<p>_____ 2.1</p> <p>① M 16 =</p> <p>1" =</p> <p>② M 16 x 1 =</p> <p>W 24 x 1/10 =</p> <p>M 2 x 0,25 =</p> <p>M 50 x 1,5 =</p>
<p>F F</p> <p>F F</p> <p>F F</p> <p>F F</p>	<p>_____ 2.2</p> <p>①</p> <p>②</p> <p>③</p> <p>④</p>
<p>①</p> <p>②</p>	<p>_____ 2.3</p> <p>①</p> <p>②</p>
<p>① ②</p>	<p>_____ 2.4</p> <p>①</p> <p>②</p>
<p>73</p>	<p>_____ 2.5</p> <p>①</p> <p>②</p>

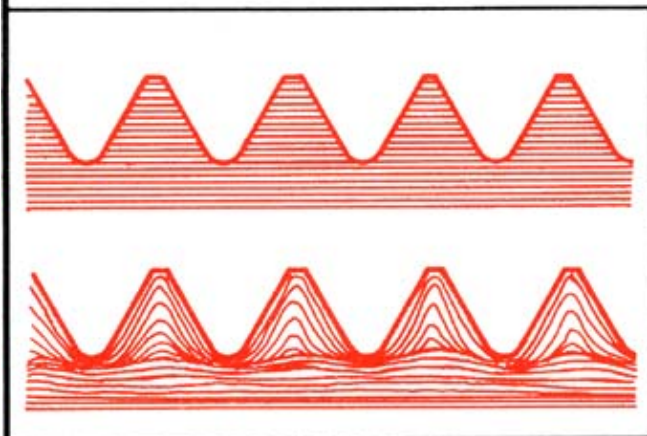

①

②

3.1



3.2

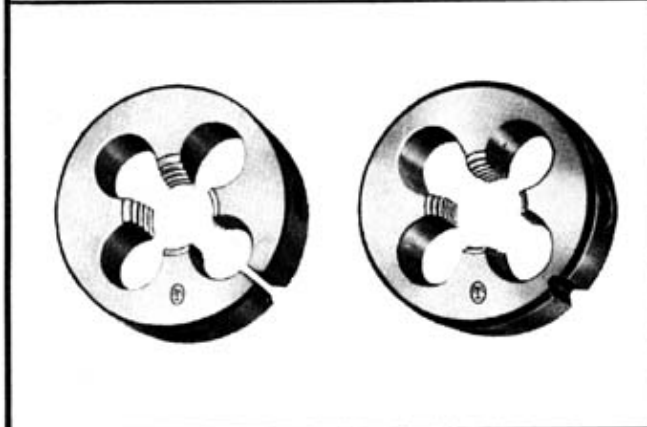

3.3

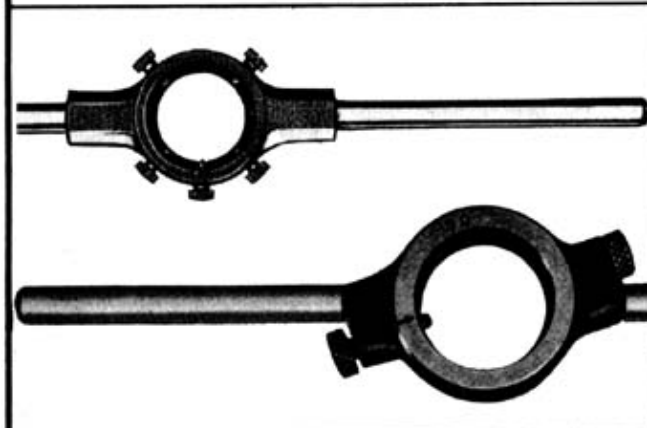

3.4



3.5

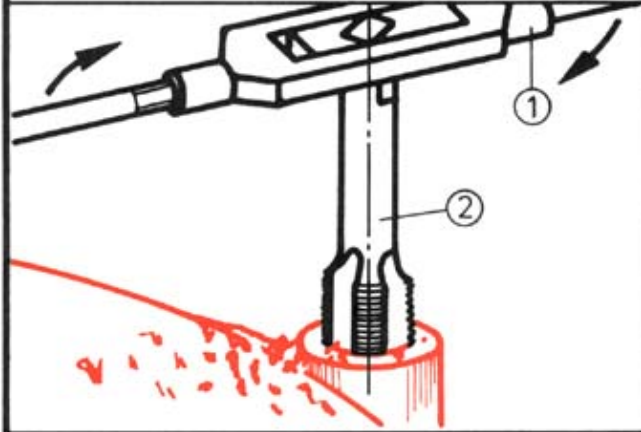

4.1

- ①
- ②

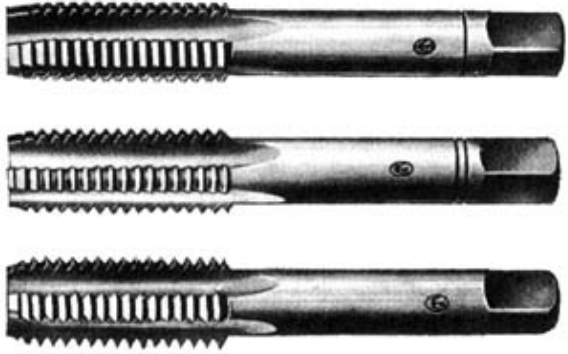

4.2

- ①
- ②
- ③

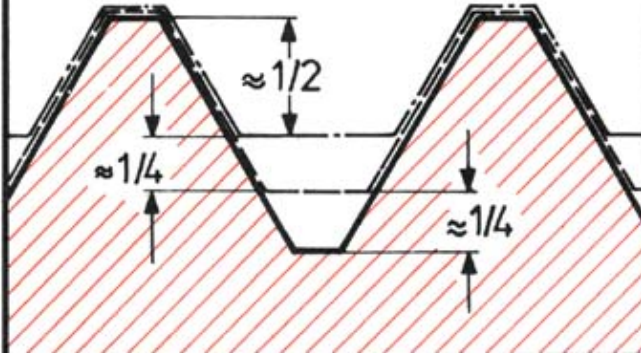

4.3

- ①
- ②
- ③

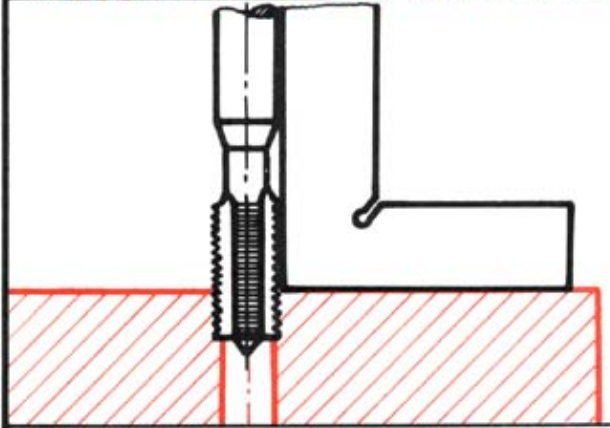

4.4



4.5

- ①



	<p>_____ 5.1</p>
	<p>_____ 5.2</p>
	<p>_____ 5.3</p>
	<p>_____ 5.4</p>
	<p>_____ 5.5</p>



	<p>_____ 6.1</p>
	<p>_____ 6.2</p>
	<p>_____ 6.3</p>
	<p>_____ 6.4</p>
	<p>_____ 6.5</p>

12. Threaded joints – Schraubenverbindungen

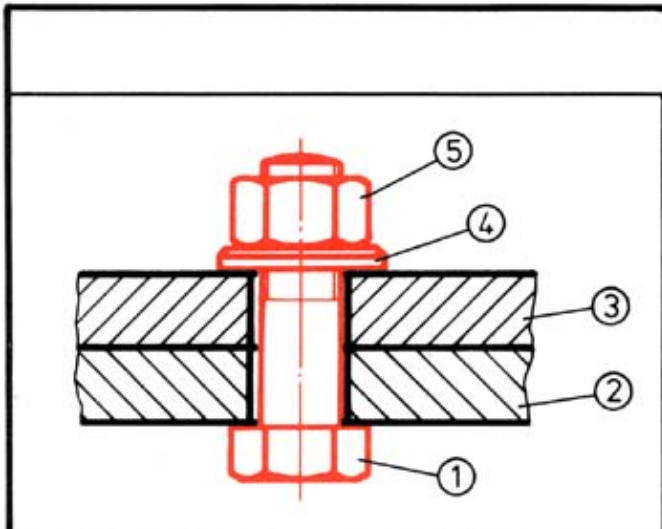
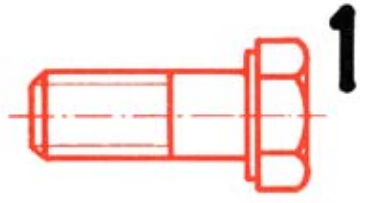

_____ 1.1

①
②
③
④
⑤

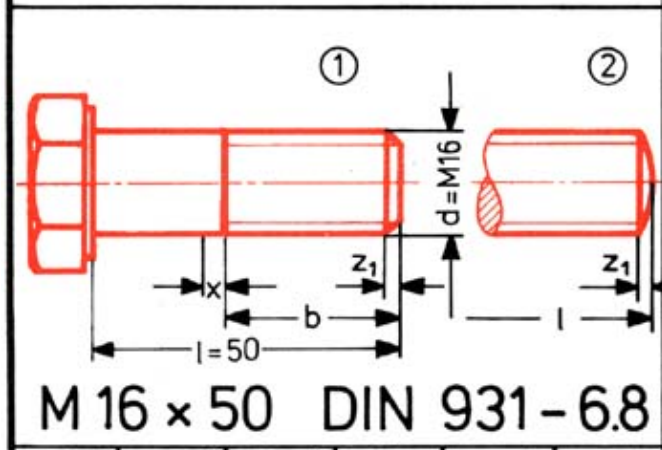

_____ 1.2

①
②
M 16 —
50 —
DIN 931-
6. .8

4A	4D	4S	5D	5S	6D	6S	6G	8G	10K	12K	-
3.6	4.6	4.8	5.6	5.8	6.6	6.8	6.9	8.8	10.9	12.9	14.9
			☒					☒	☐	☐	☐

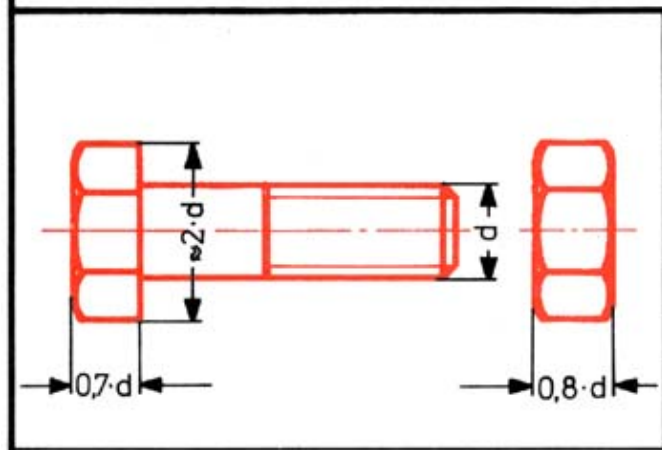

_____ 1.4



_____ 1.5

①

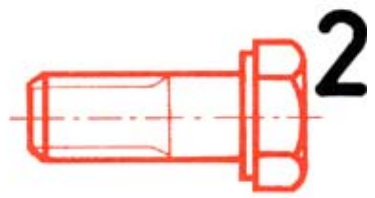

2

	<p>_____ 2.1</p> <p>①</p> <p>②</p> <p>③</p> <p>④</p>
	<p>_____ 2.2</p> <p>①</p> <p>②</p> <p>③</p>
	<p>_____ 2.3</p> <p>①</p> <p>②</p> <p>③</p>
	<p>_____ 2.4</p> <p>①</p> <p>②</p>
	<p>_____ 2.5</p> <p>①</p> <p>②</p>

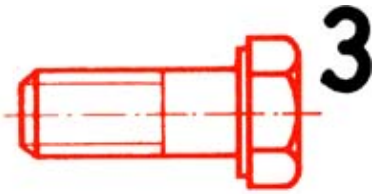

3

<p style="text-align: center;">① ②</p>	<p style="text-align: right;">_____ 3.1</p> <p>①</p> <p>②</p>
<p style="text-align: center;">DIN 93 DIN 432</p>	<p style="text-align: right;">_____ 3.2</p> <p>①</p> <p>②</p> <p>③</p>
	<p style="text-align: right;">_____ 3.3</p> <p>①</p> <p>②</p> <p>③</p>
	<p style="text-align: right;">_____ 3.4</p> <p>①</p> <p>②</p> <p>③</p> <p>④</p>
<p>81</p>	<p style="text-align: right;">_____ 3.5</p>

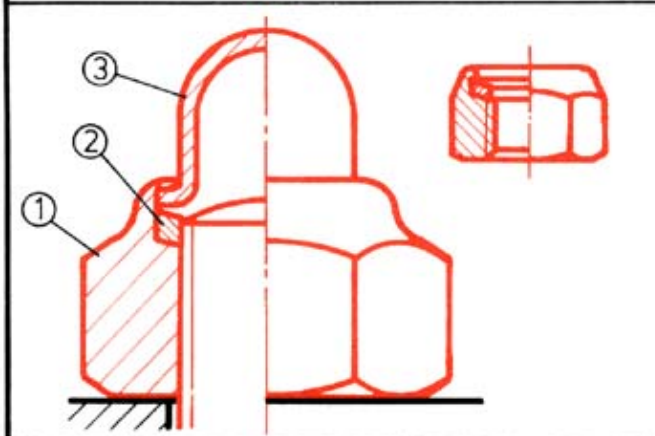
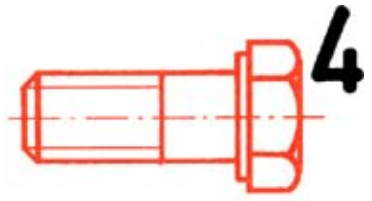

_____ 4.1

- ①
- ②
- ③

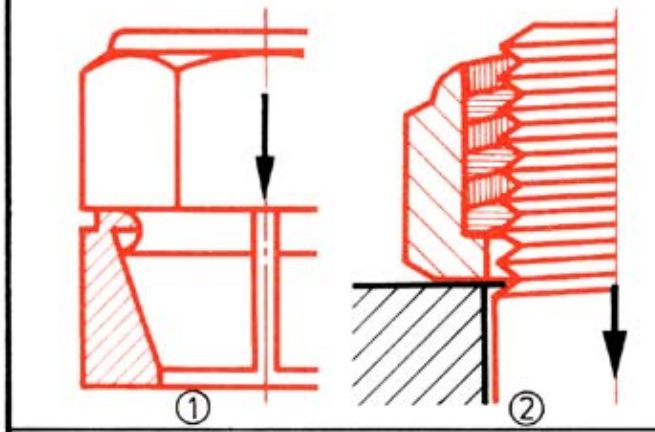

_____ 4.2

- ①
- ②

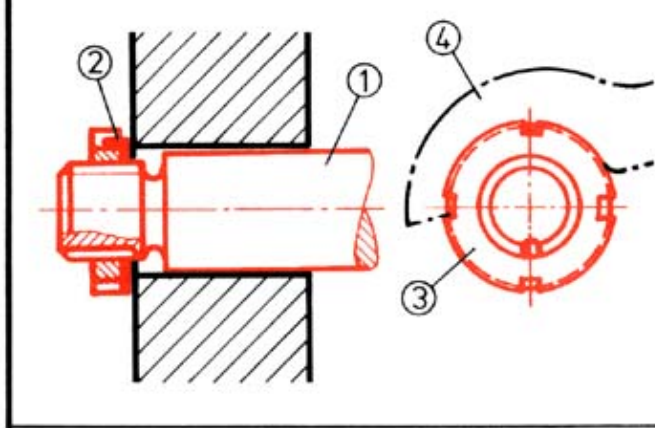

_____ 4.3

- ①
- ②
- ③
- ④

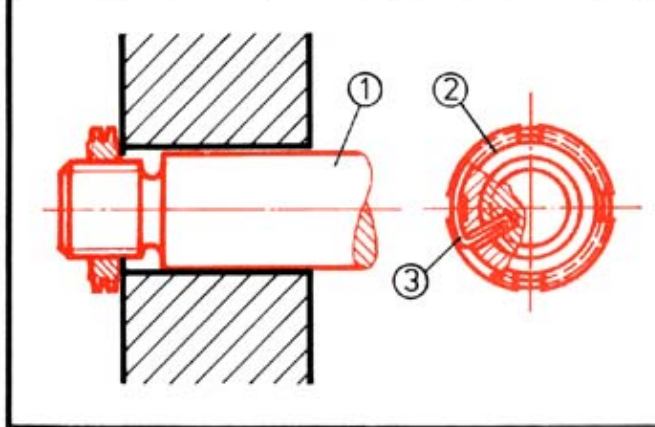

_____ 4.4

- ①
- ②
- ③



_____ 4.5

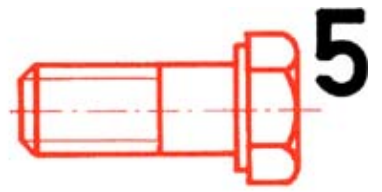

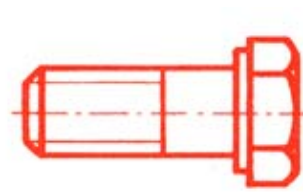

5

<p>① ② ③</p>	<p>_____ 5.1</p> <p>①</p> <p>②</p> <p>③</p>
<p>① ② ③</p>	<p>_____ 5.2</p> <p>①</p> <p>②</p> <p>③</p>
<p>① ② ③</p> <p>① ② ③</p>	<p>_____ 5.3</p> <p>①</p> <p>②</p> <p>③</p>
<p>①</p> <p>②</p> <p>③</p>	<p>_____ 5.4</p> <p>①</p> <p>②</p> <p>③</p>
<p>83</p>	<p>_____ 5.5</p>

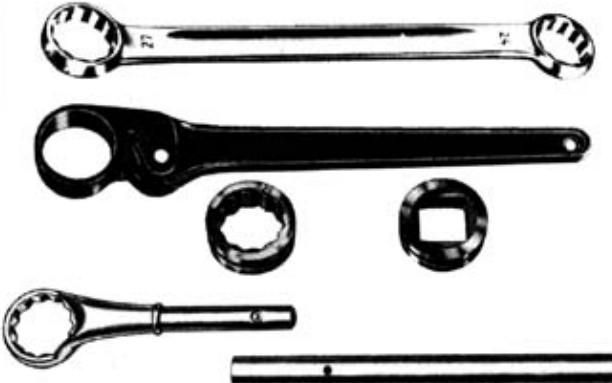
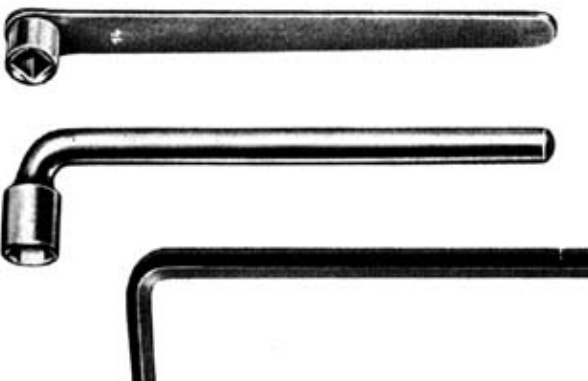
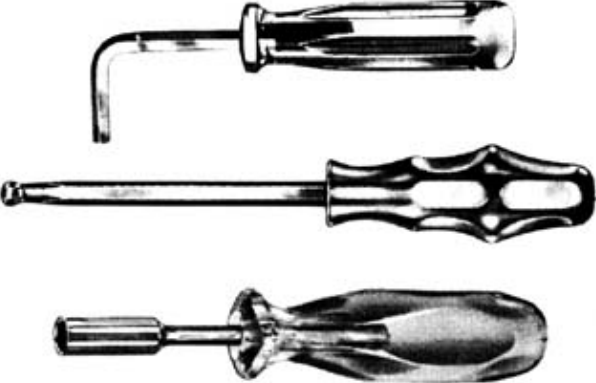

6

	<p>_____ 6.1</p>
	<p>_____ 6.2</p>
	<p>_____ 6.3</p>
	<p>_____ 6.4</p>
	<p>_____ 6.5</p>

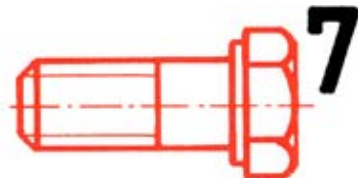

_____ 7.1

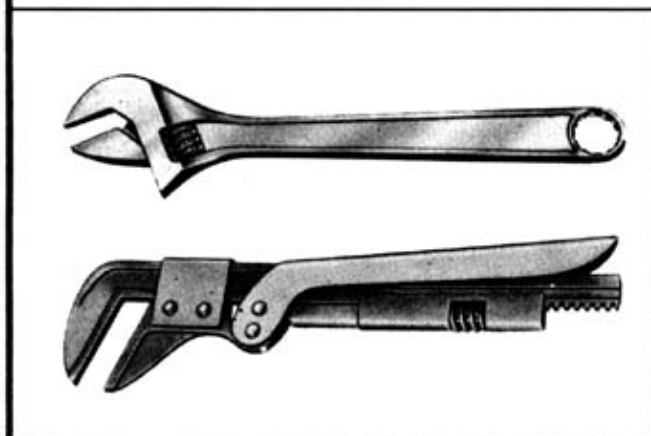

_____ 7.2

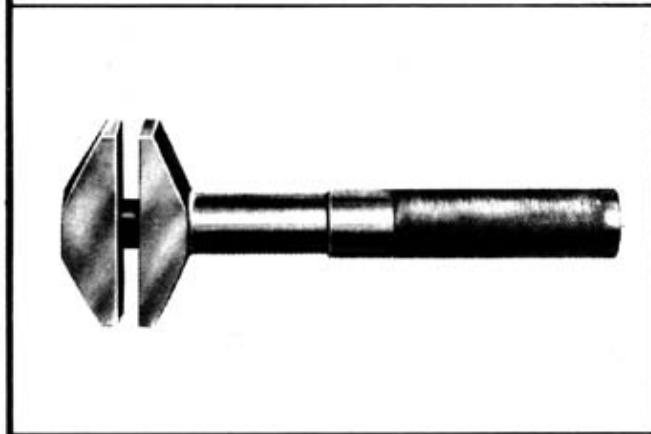

_____ 7.3

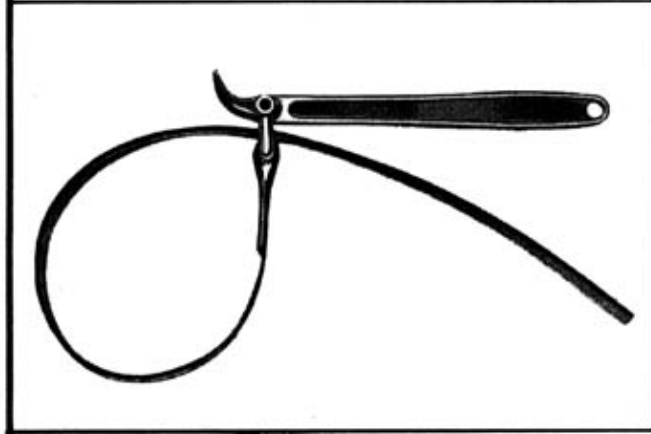

_____ 7.4



_____ 7.5

13. Keyed joints – Keilverbindungen

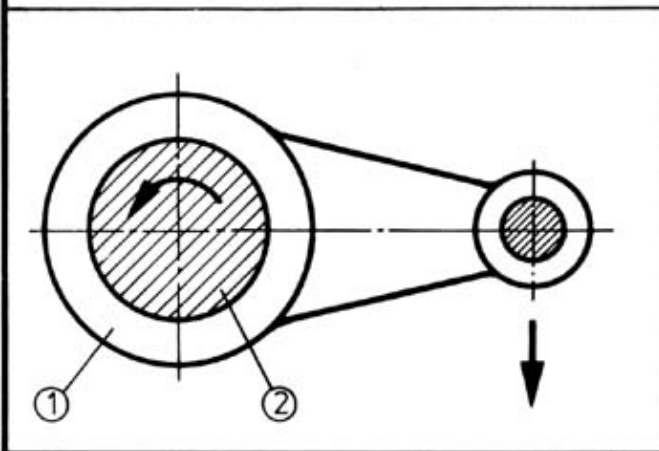
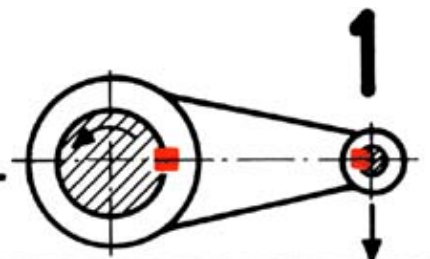

_____ 1.1

①

②

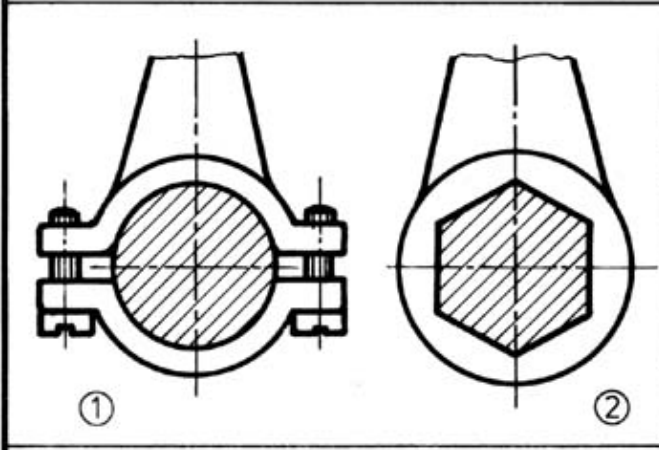

_____ 1.2

①

②

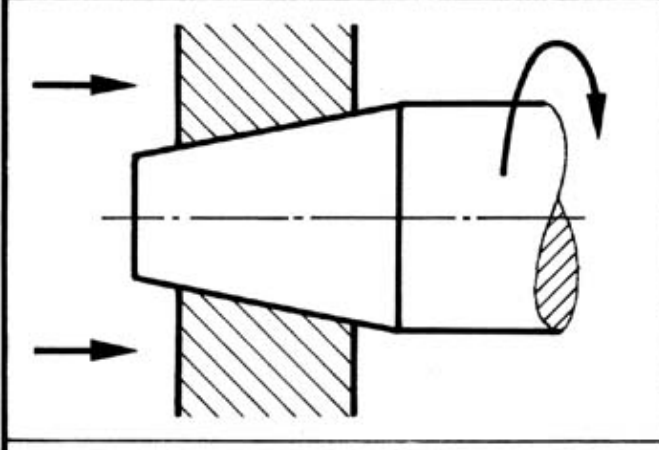

_____ 1.3

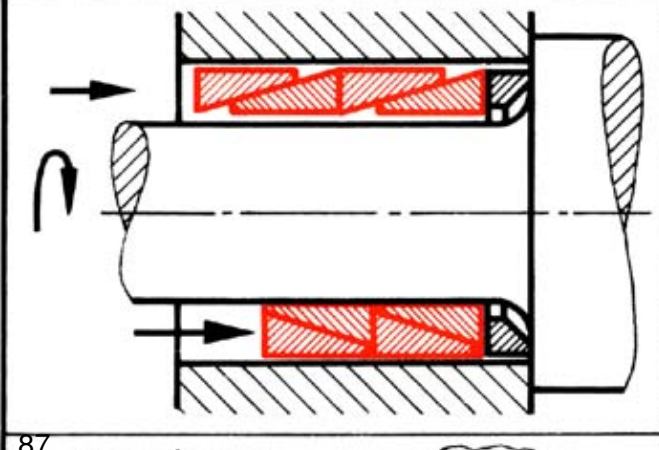

_____ 1.4



_____ 1.5

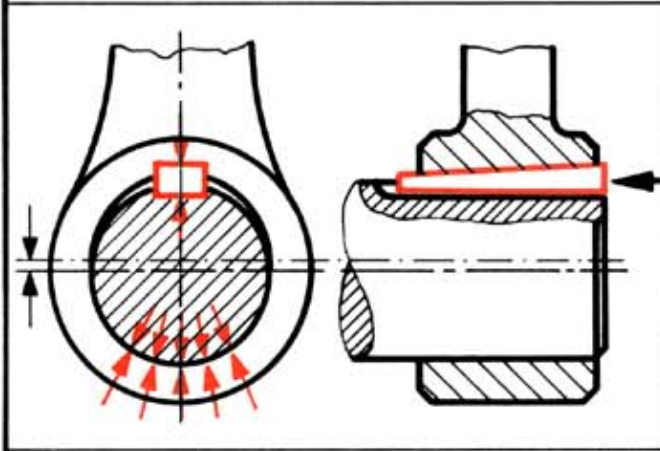
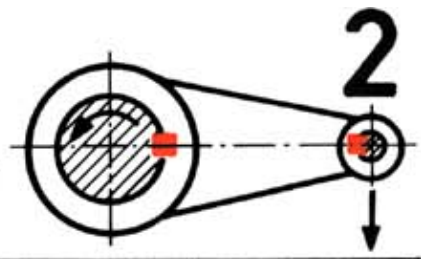

_____ 2.1

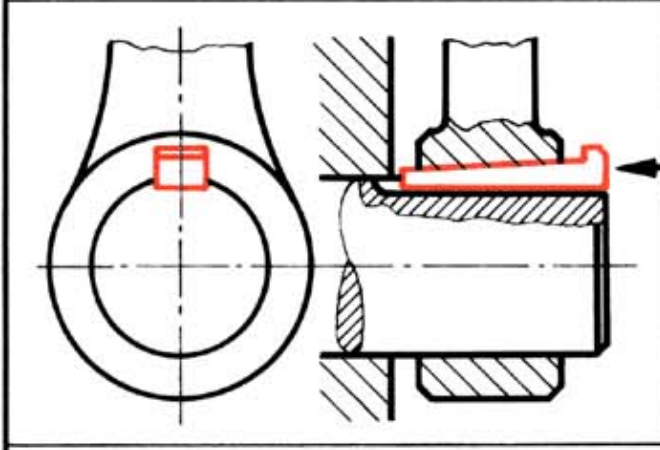

_____ 2.2

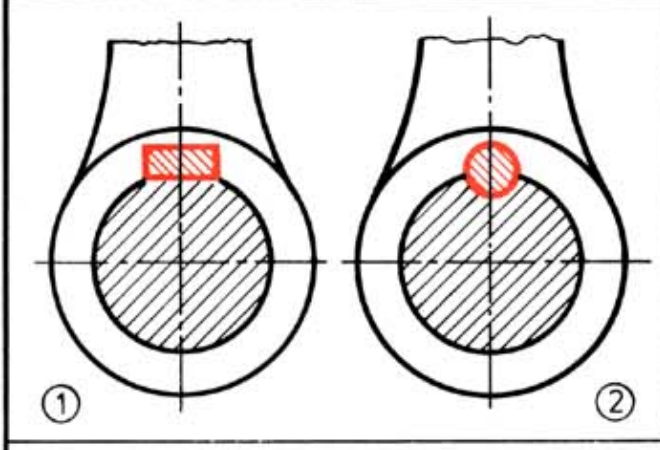
_____ 2.3

①

②

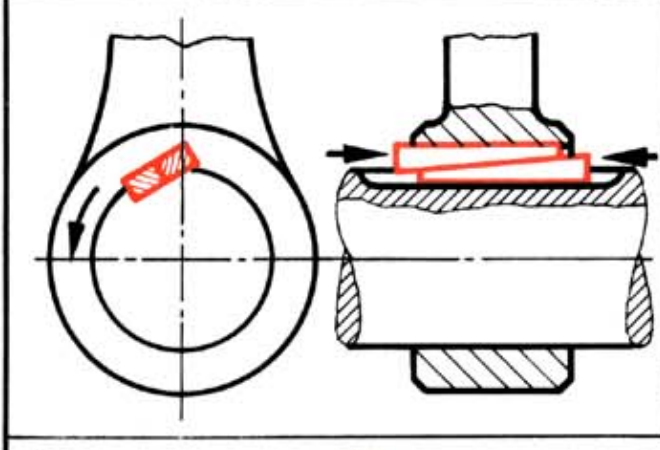

_____ 2.4



_____ 2.5

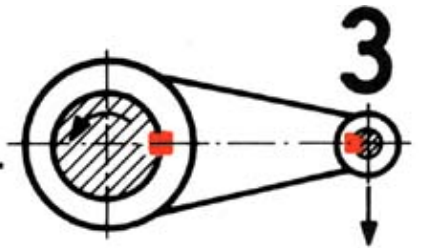

<p style="text-align: center;">① ②</p> <p style="text-align: center;">1 : 100</p>	<p style="text-align: right;">3.1</p> <hr/> <p>①</p> <p>②</p>
	<p style="text-align: right;">3.2</p> <hr/>
	<p style="text-align: right;">3.3</p> <hr/>
<p style="text-align: center;">① ②</p> <p style="text-align: center;">① ②</p>	<p style="text-align: right;">3.4</p> <hr/> <p>①</p> <p>②</p>
<p>89</p>	<p style="text-align: right;">3.5</p> <hr/>

4

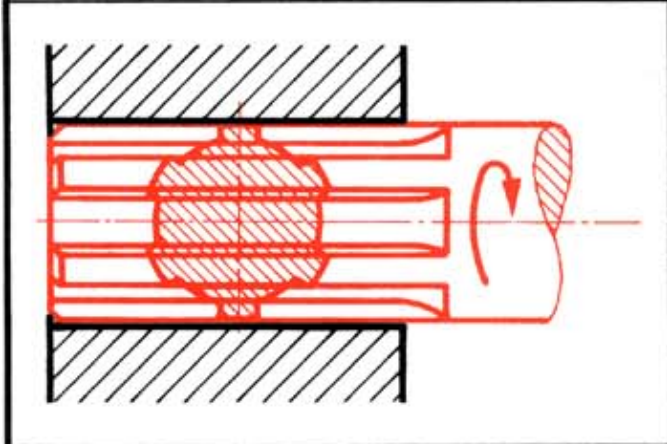
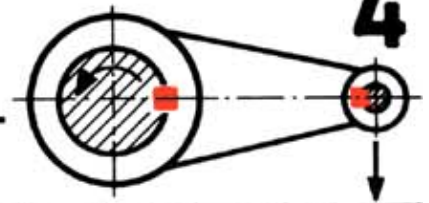

4.1

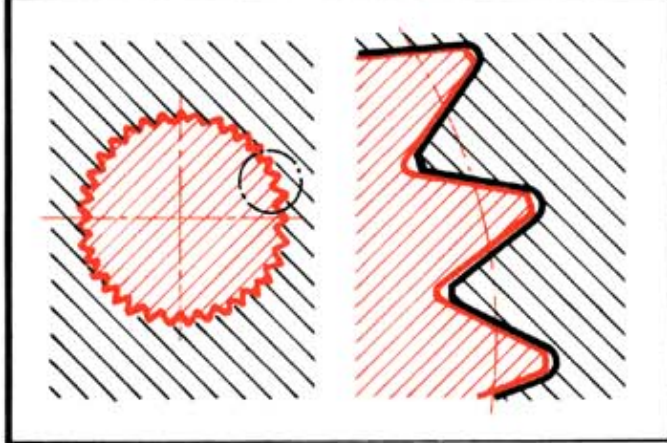

4.2

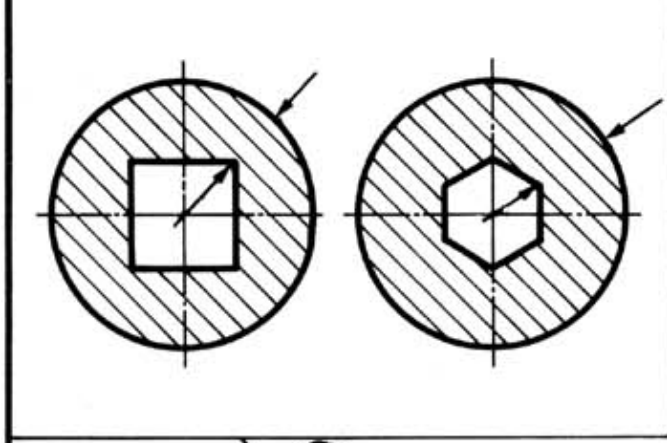

4.3

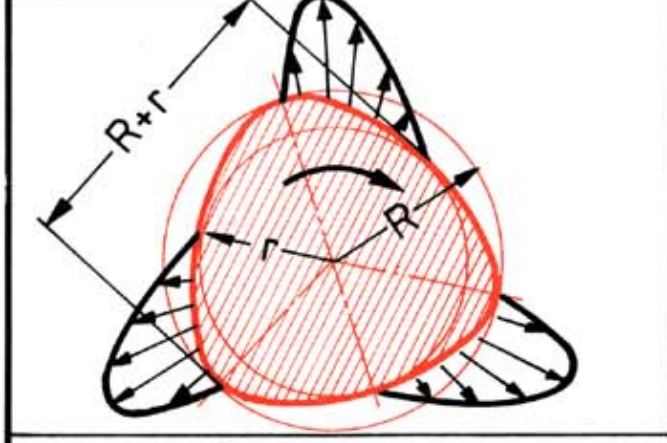

4.4



4.5

5

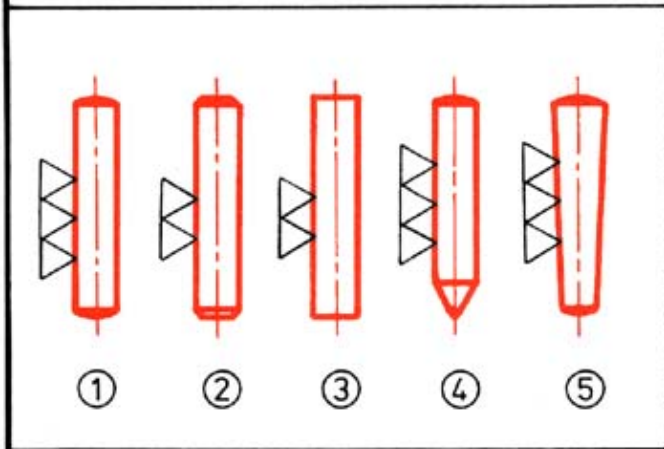
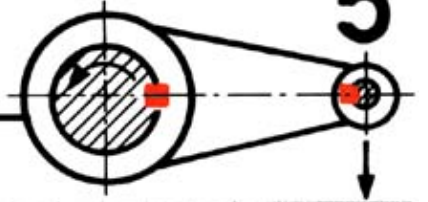

- ①
- ②
- ③
- ④
- ⑤

5.1

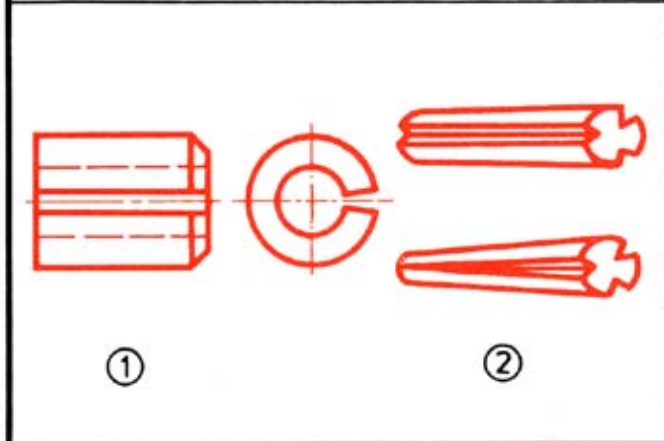

- ①
- ②

5.2

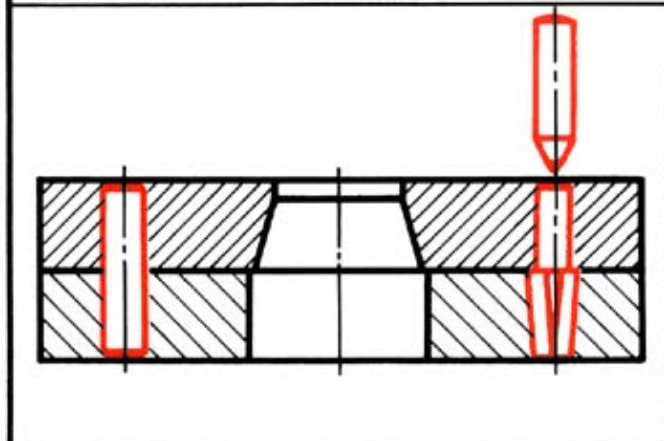

- ①

5.3

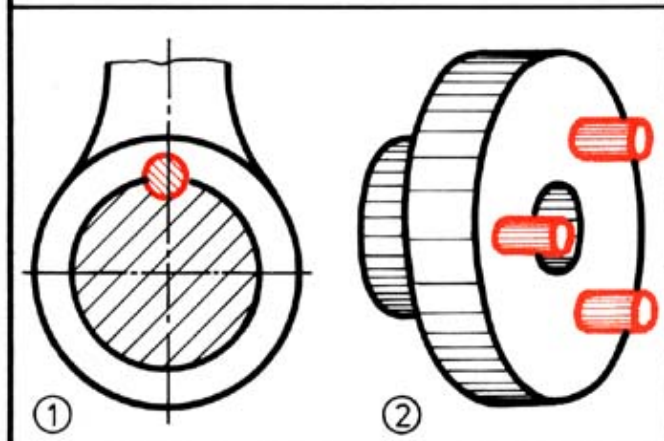

- ①
- ②

5.4



- ①

5.5

6

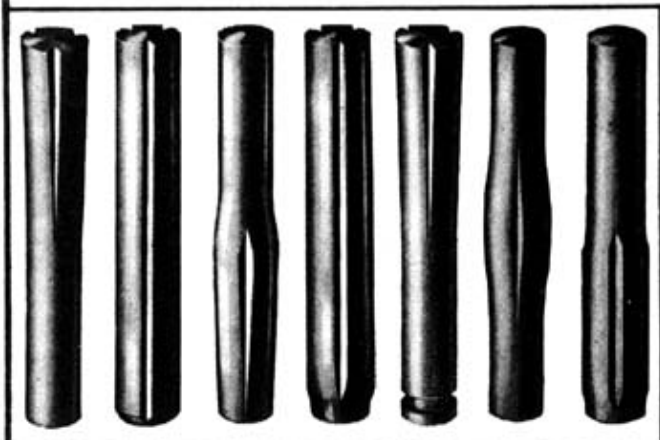
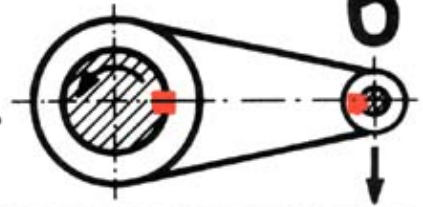

6.1

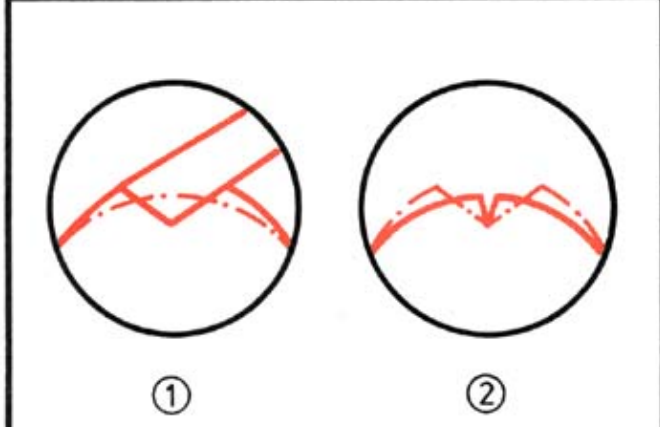

6.2

- ①
- ②

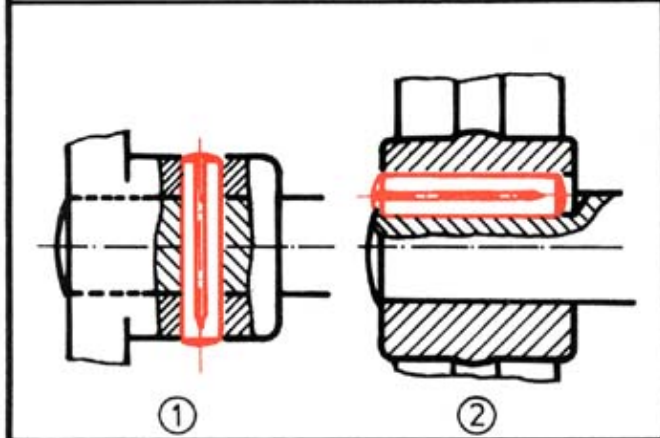

6.3

- ①
- ②

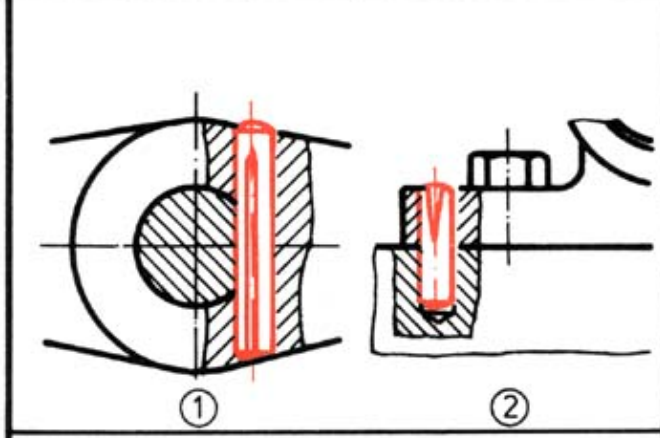

6.4

- ①
- ②



6.5

- ①

14. Soldering joints – Lötverbindungen

1

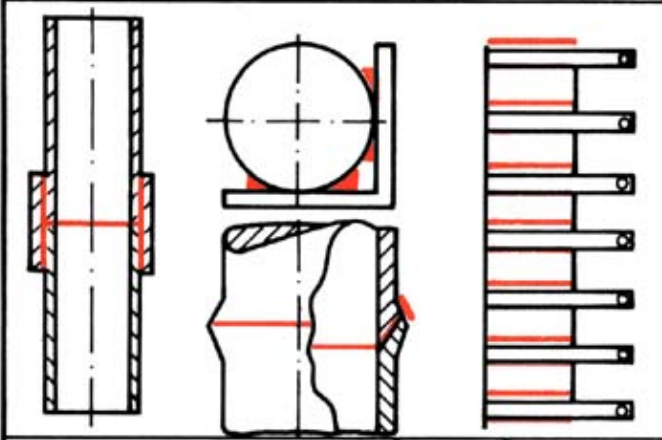

1.1

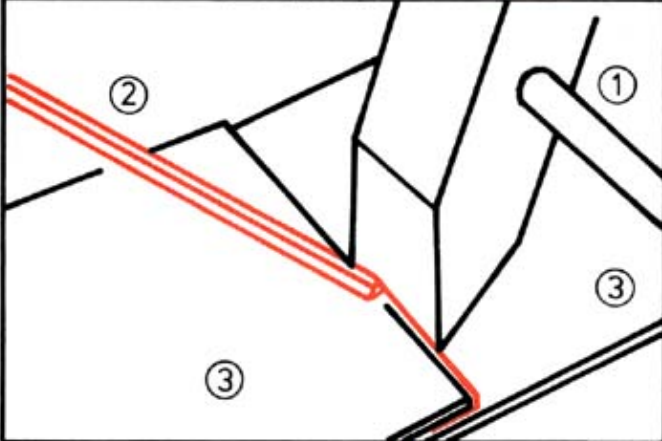

1.2

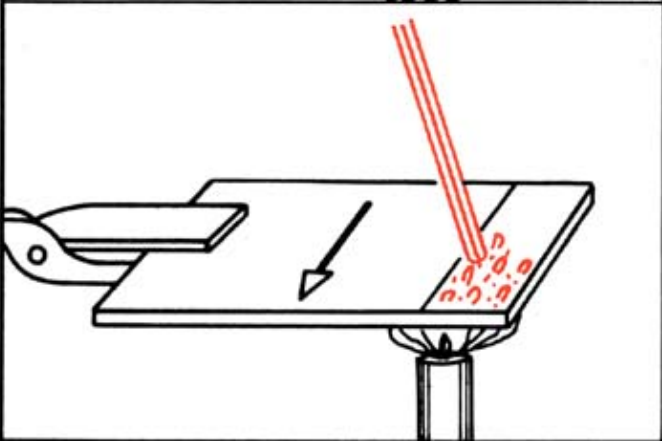

1.3

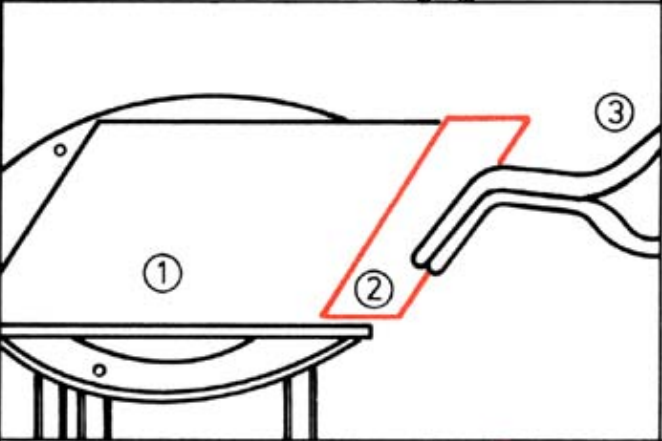

1.4



1.5

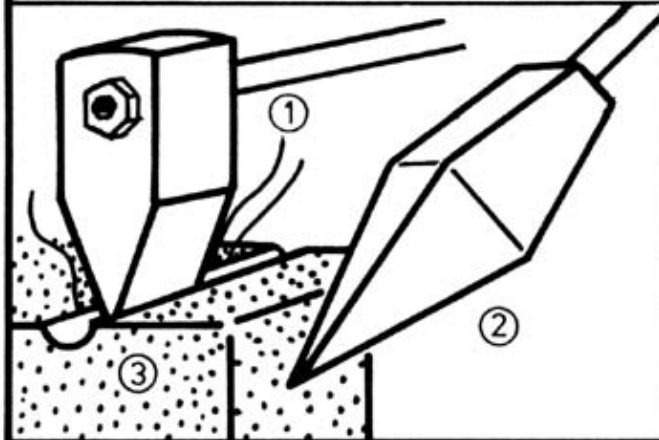

_____ 2.1

- ①
- ②
- ③



_____ 2.2



_____ 2.3

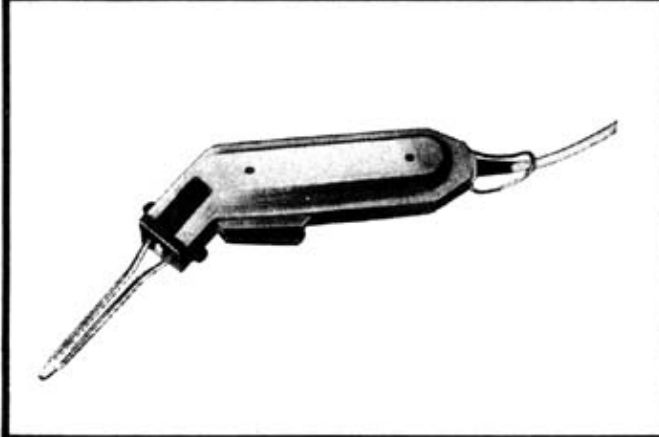

_____ 2.4



_____ 2.5

3



3.1

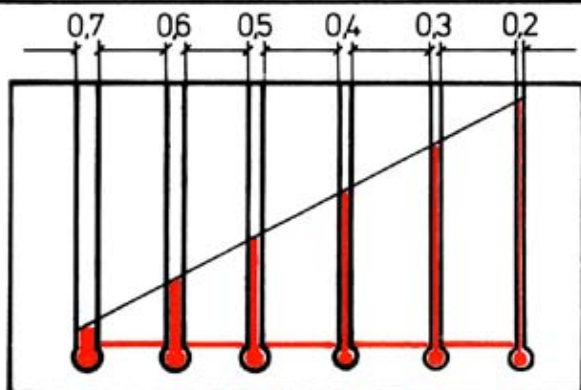

3.2

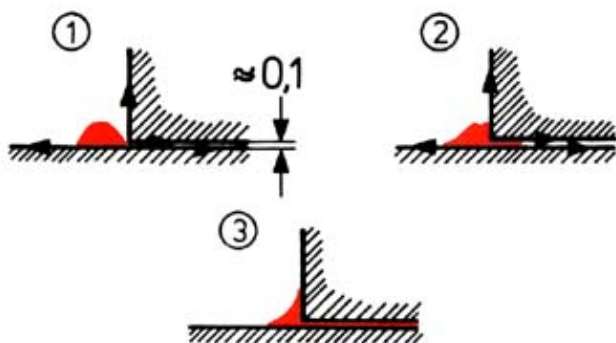

- ①
- ②
- ③

3.3

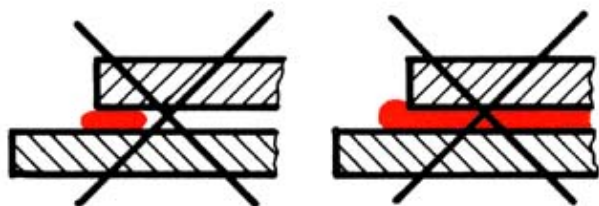

3.4

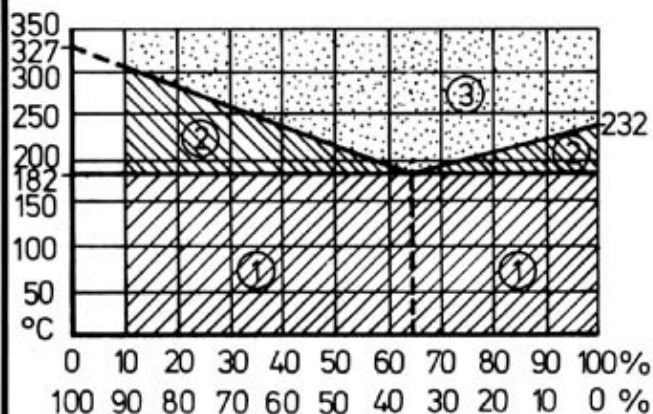

- ①
- ②
- ③

3.5

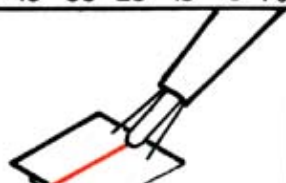
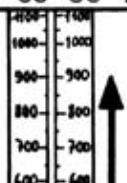

1080 °C —
945°...1020°C-

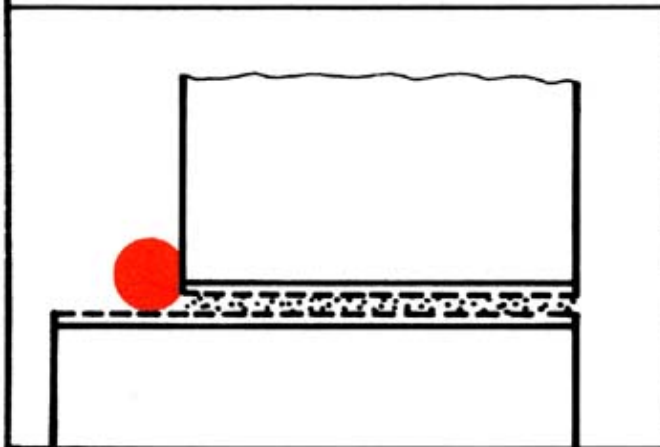

_____ 4.1

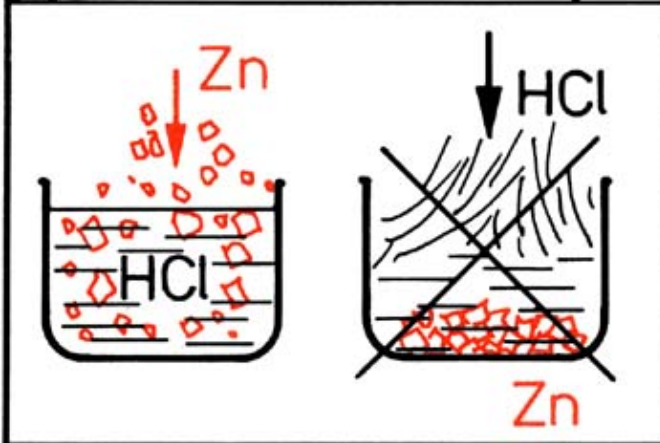

_____ 4.2

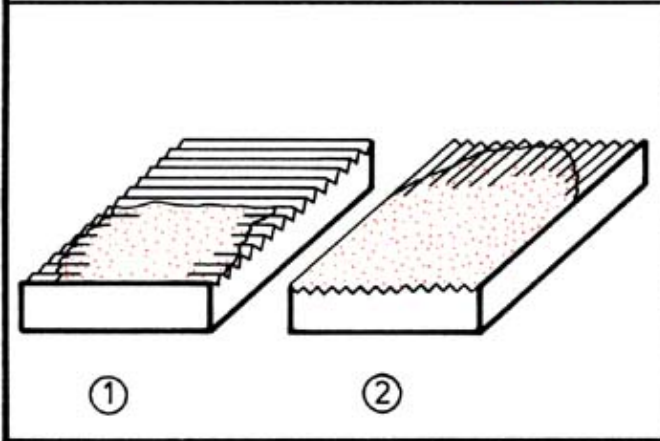

_____ 4.3

- ①
- ②

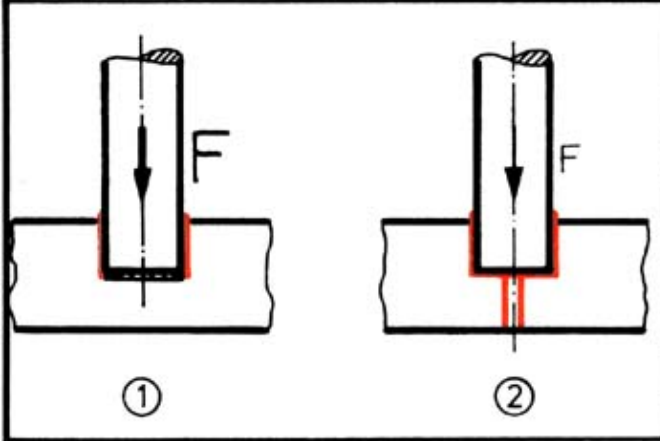

_____ 4.4

- ①
- ②



_____ 4.5

15. Welded joints – Schweißverbindungen

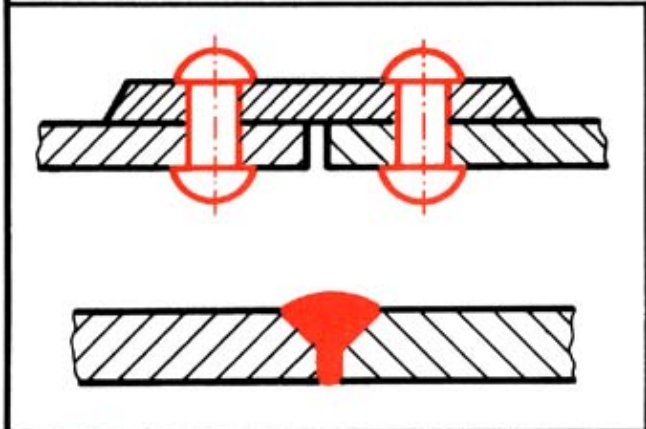
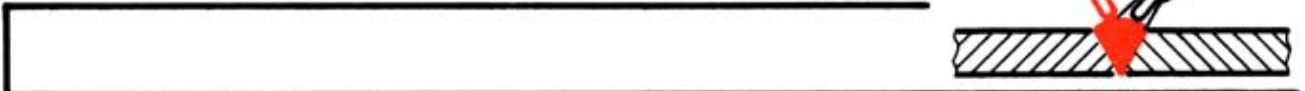
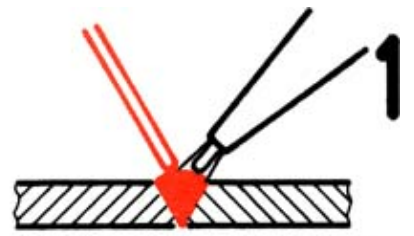

_____ 1.1

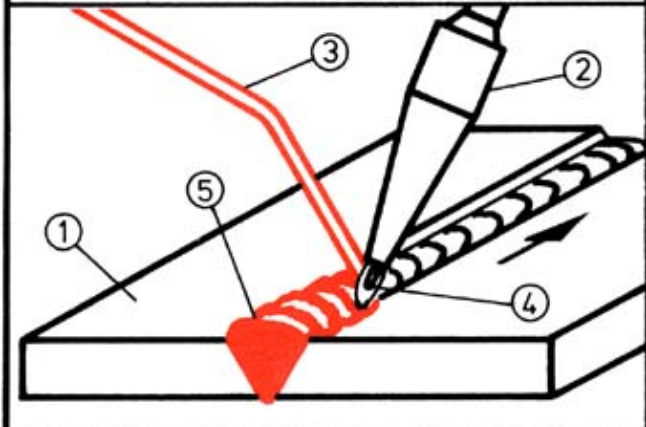

_____ 1.2

①
②
③
④
⑤

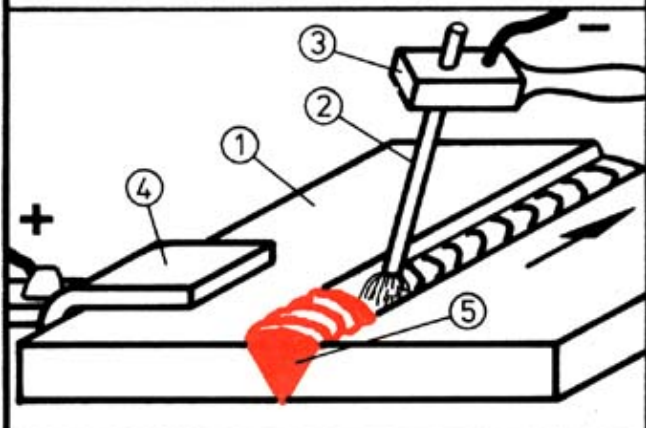

_____ 1.3

①
②
③
④
⑤

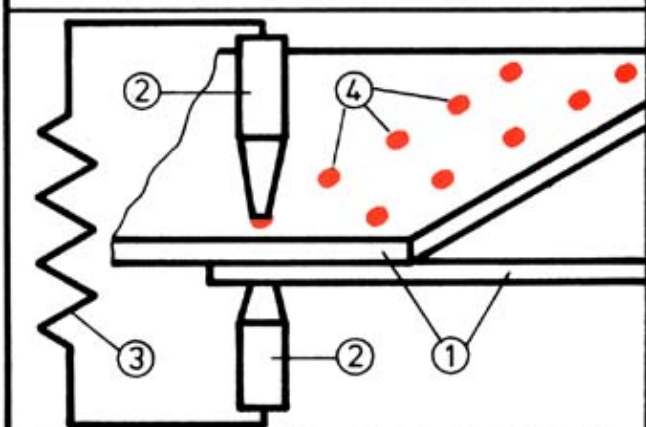

_____ 1.4

①
②
③
④



_____ 1.5

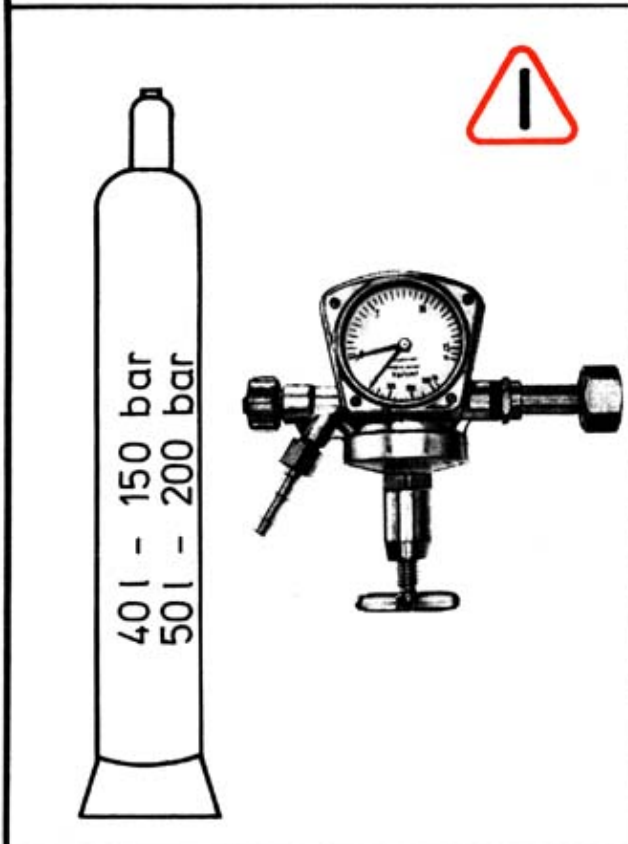
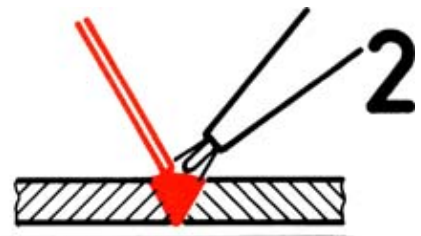

_____ 2.1
 O_2^-

_____ 2.2
 H_2^-

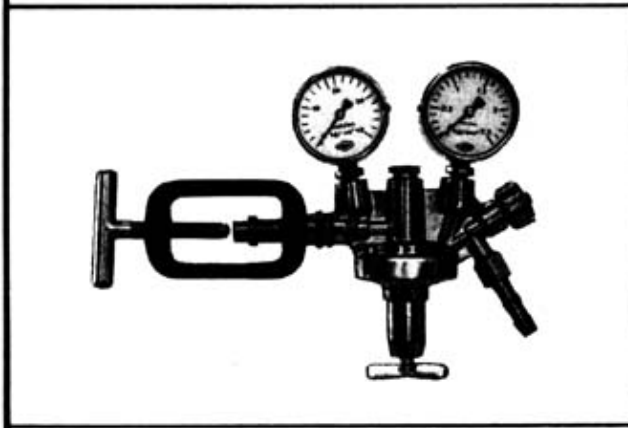

_____ 2.3
 $C_2H_2^-$

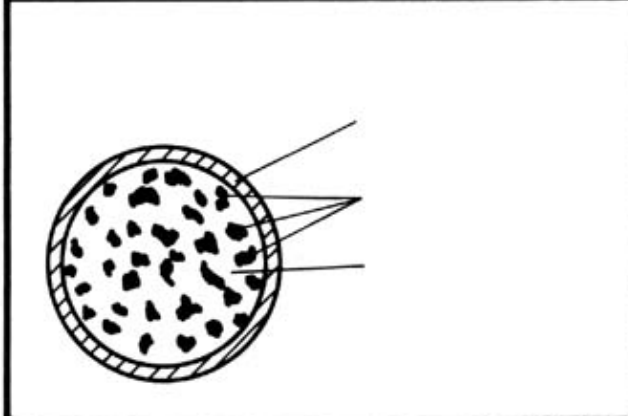

_____ 2.4
 $C_2H_2^-$
⚠

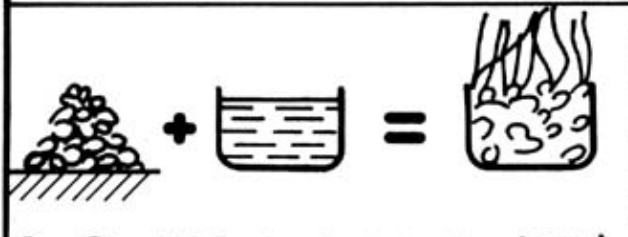

_____ 2.5
⚠

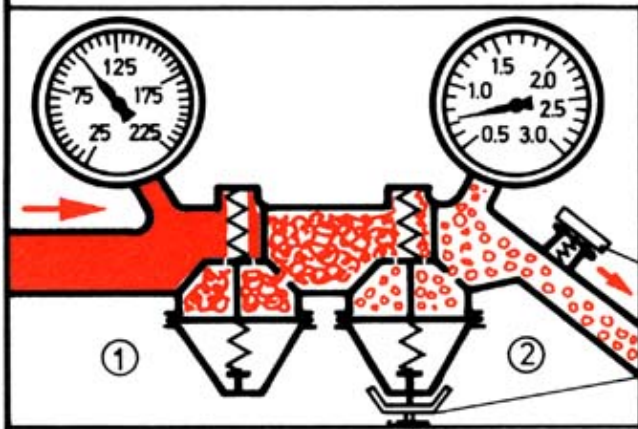
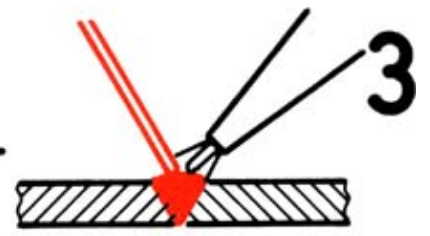

_____ 3.1

① _____

② _____

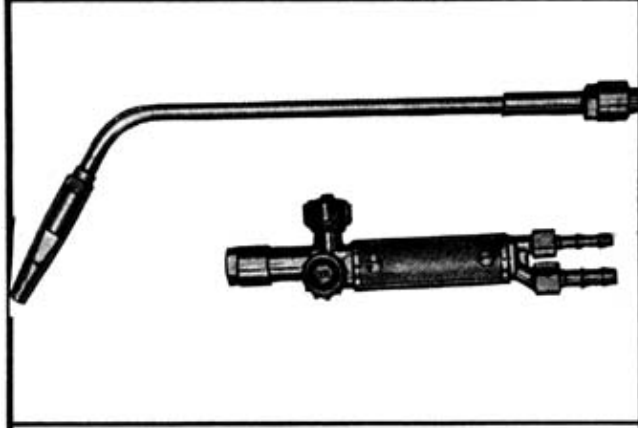

_____ 3.2

① _____

② _____

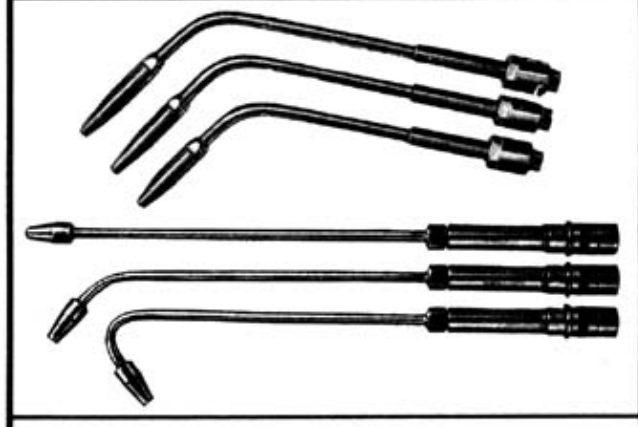

_____ 3.3

① _____

② _____

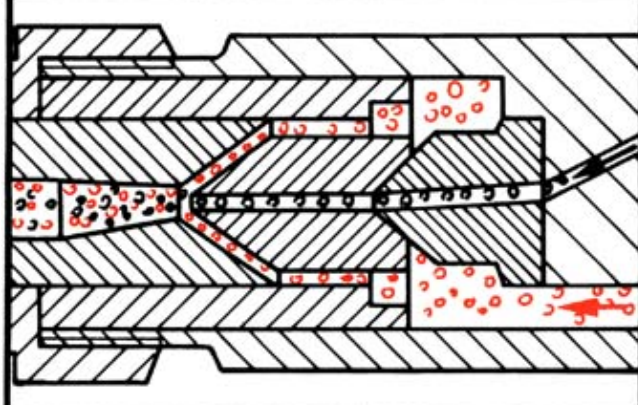

_____ 3.4

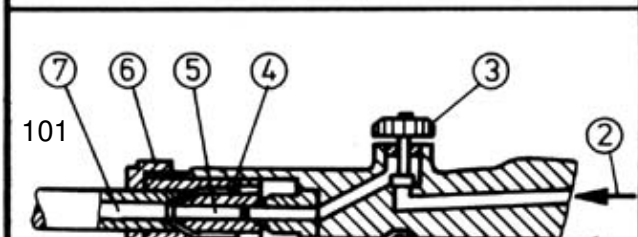

_____ 3.5

① _____

② _____

③ _____

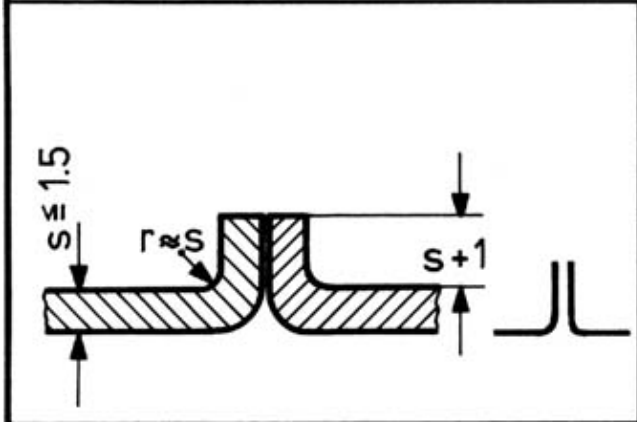
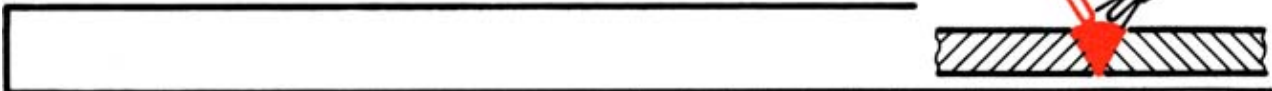
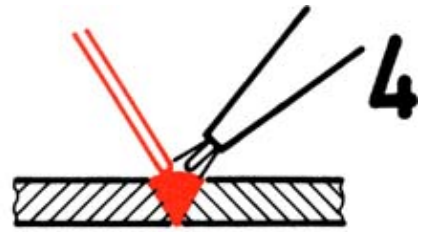

_____ 4.1

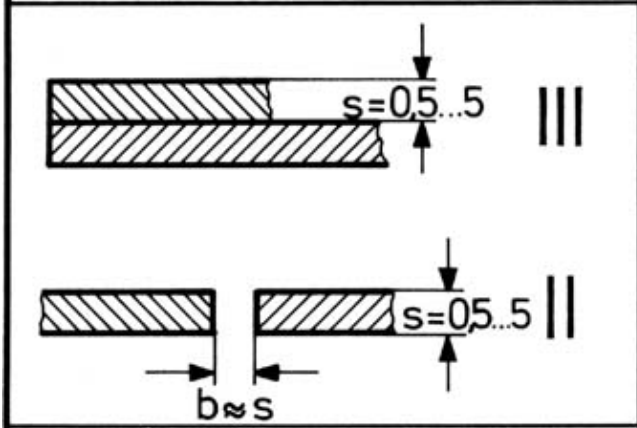

_____ 4.2

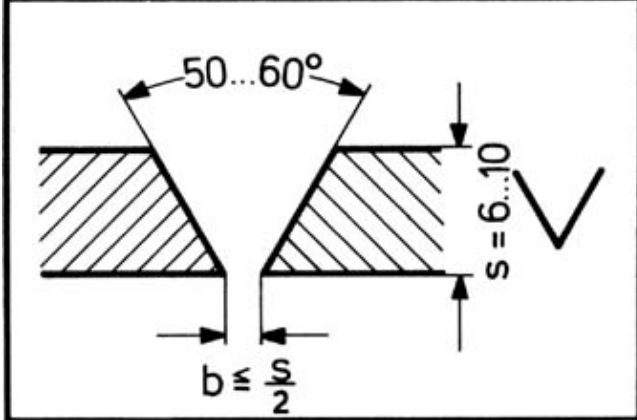

_____ 4.3

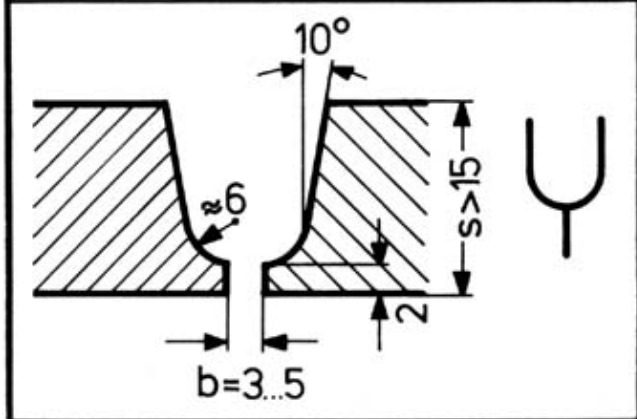

_____ 4.4

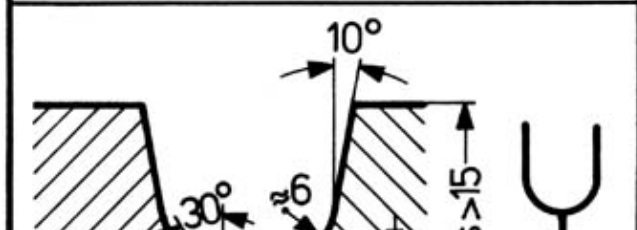

_____ 4.5

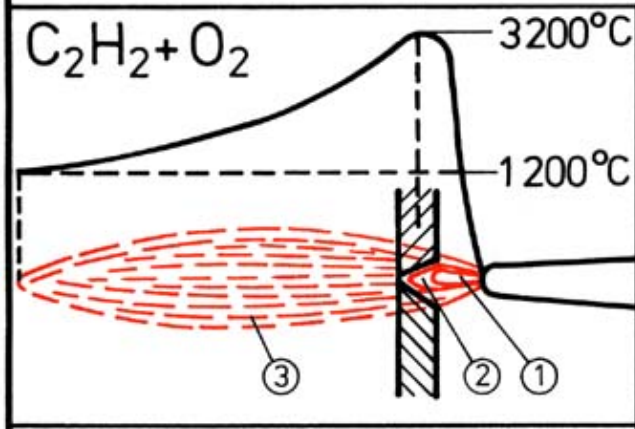
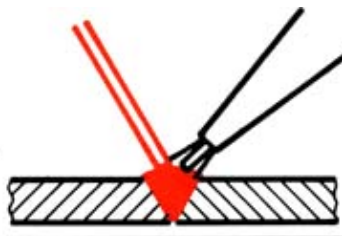

_____ 5.1

①

②

③

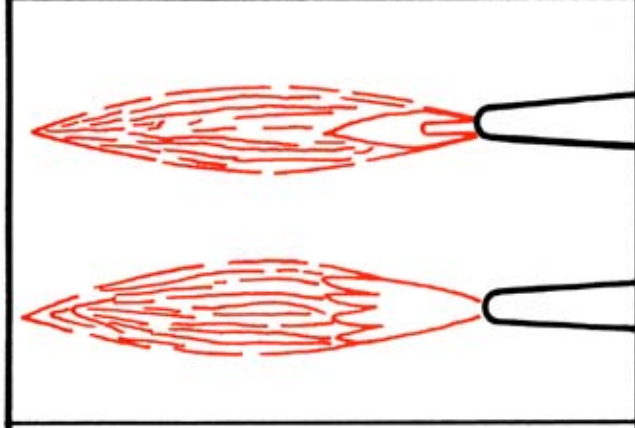

_____ 5.2

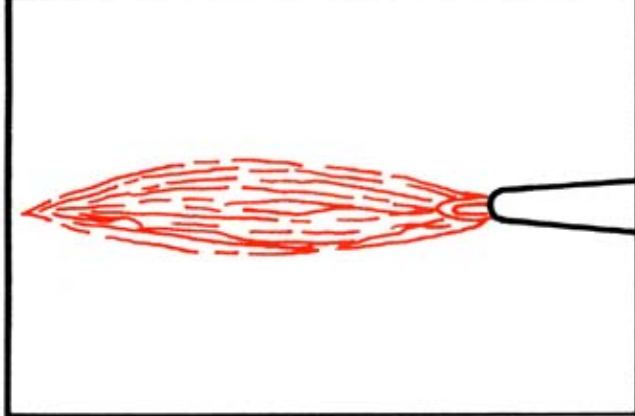

_____ 5.3

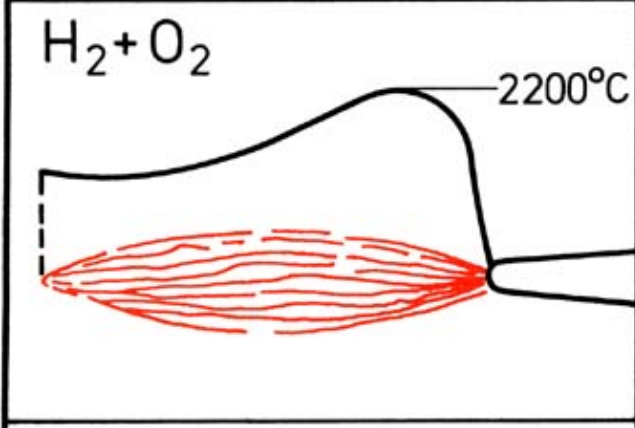

_____ 5.4

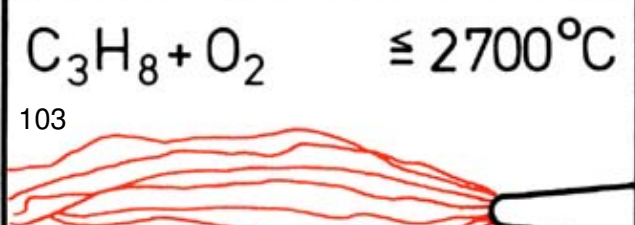

_____ 5.5

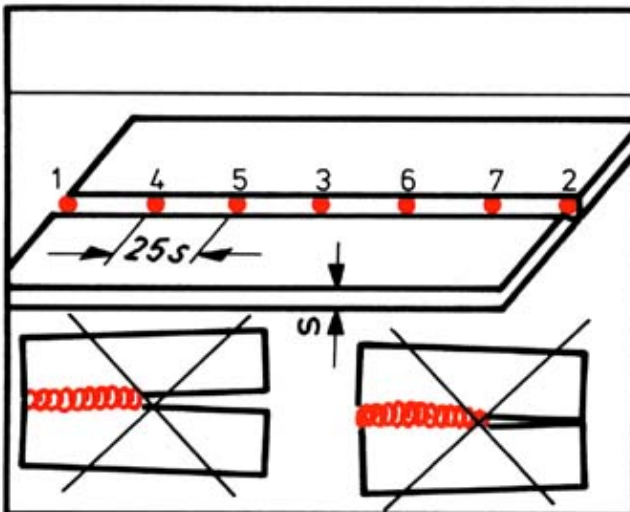
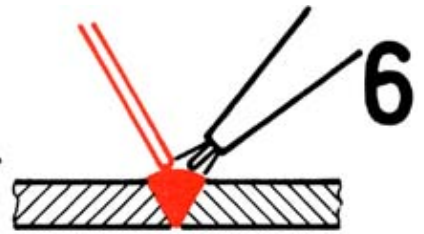

_____ 6.1

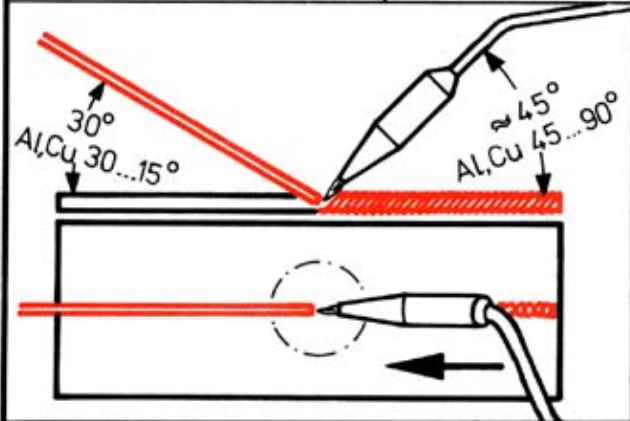

_____ 6.2

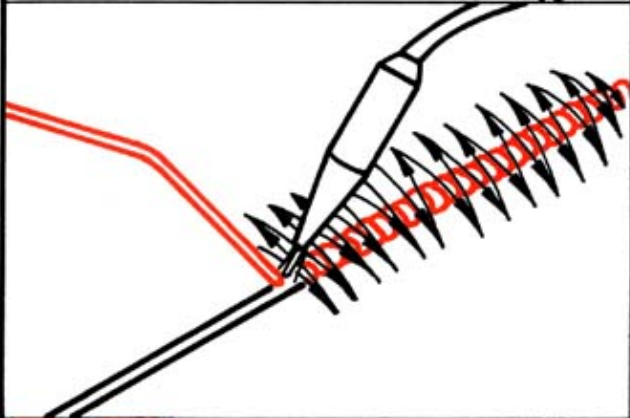

_____ 6.3

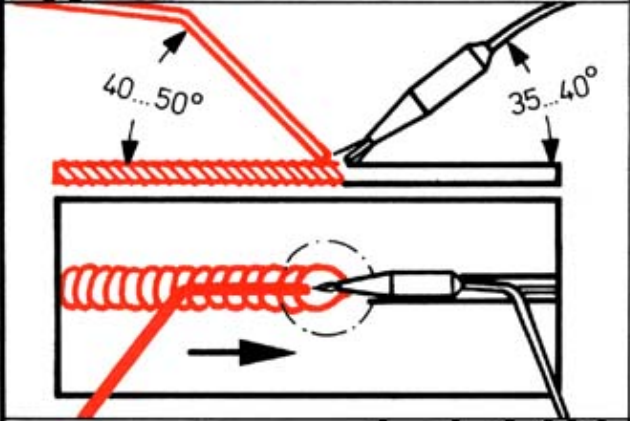

_____ 6.4



_____ 6.5

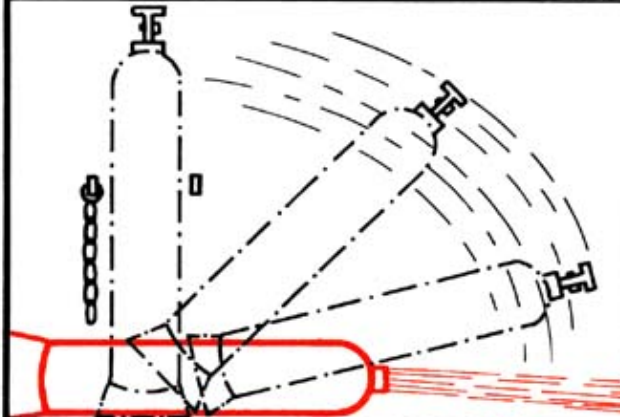
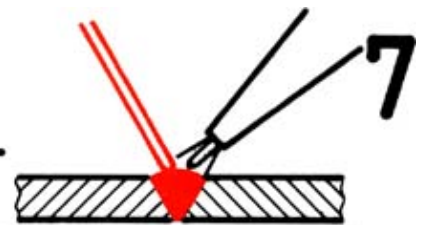

7.1

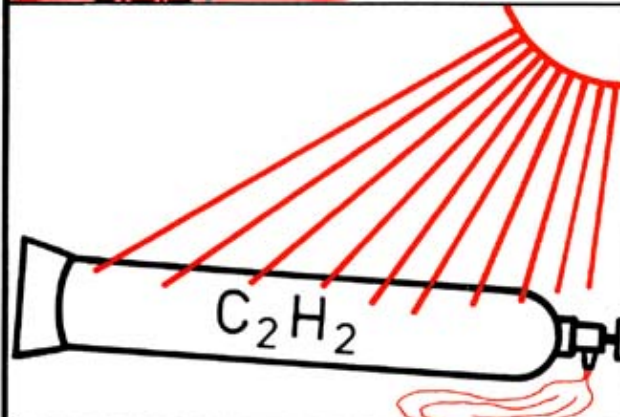

7.2



7.3



7.4



7.5



16. Folding/Bending – Umformen/Biegen

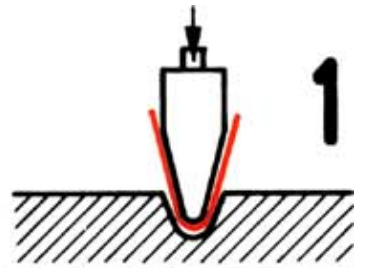

	<p>_____ 1.1</p>
	<p>_____ 1.2</p>
	<p>_____ 1.3</p>
	<p>_____ 1.4</p>
	<p>_____ 1.5</p>



2

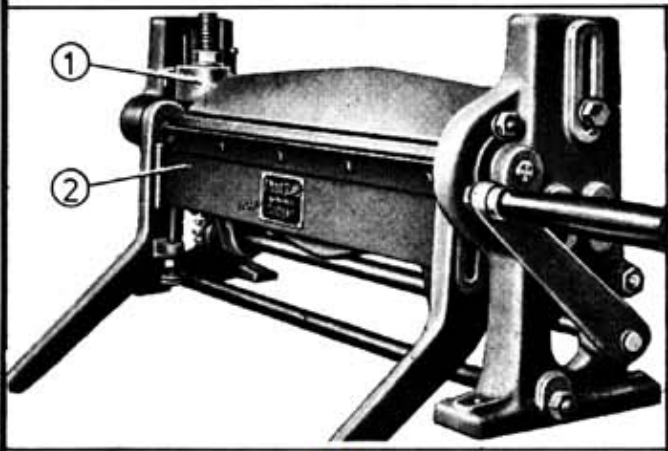

1.2

- ①
- ②

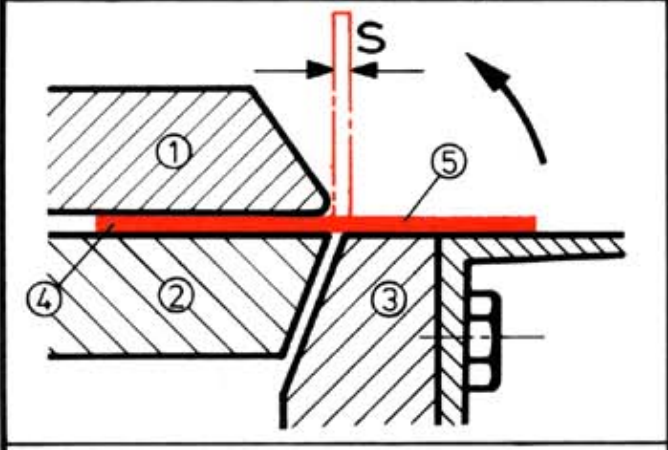

2.2

- ①
- ②
- ③
- ④
- ⑤

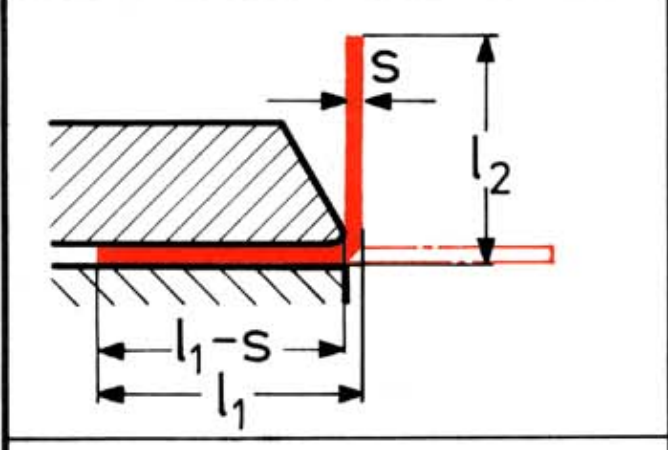

2.3

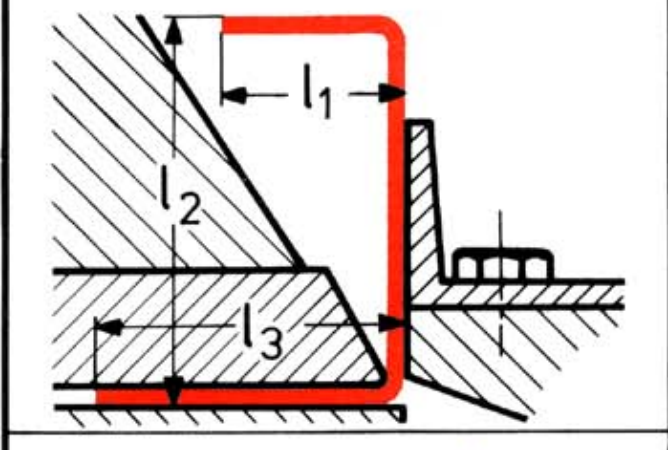

2.4



2.5

3

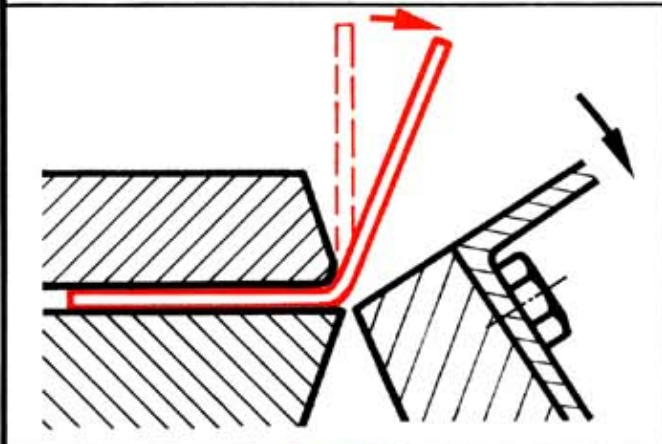
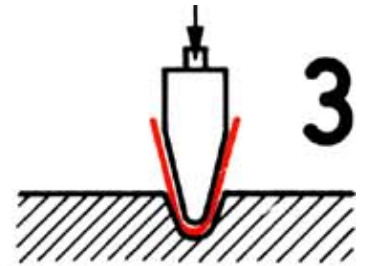

3.1

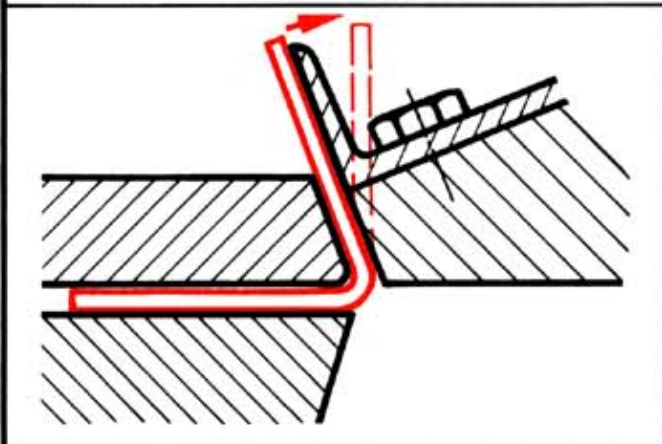

3.2

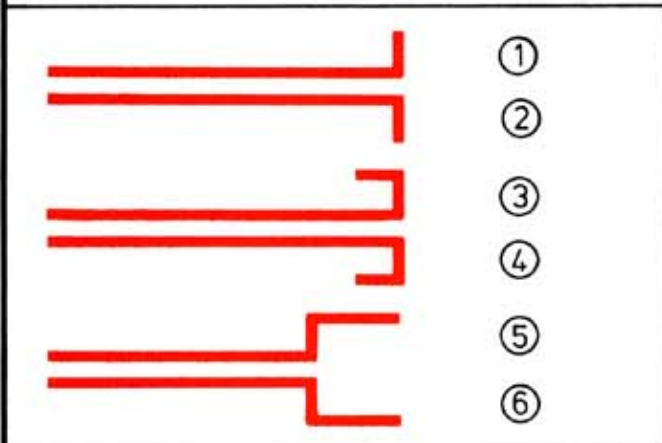

3.3



3.4



3.5

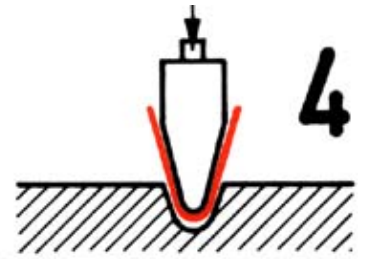

4

	<p>_____ 4.1</p> <p>①</p> <p>②</p>
	<p>_____ 4.2</p>
	<p>_____ 4.3</p>
	<p>_____ 4.4</p>
	<p>_____ 4.5</p>



5

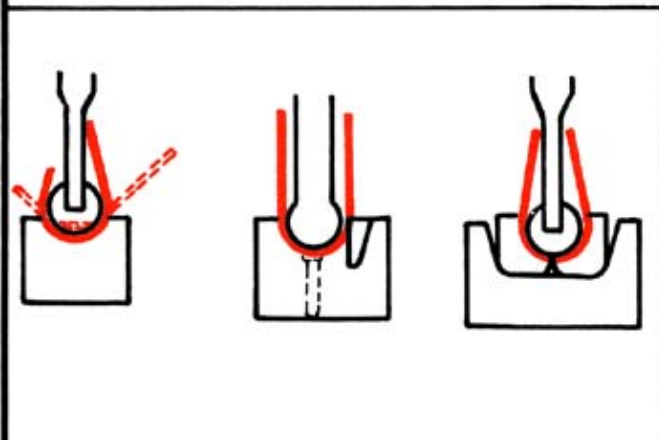

5.1

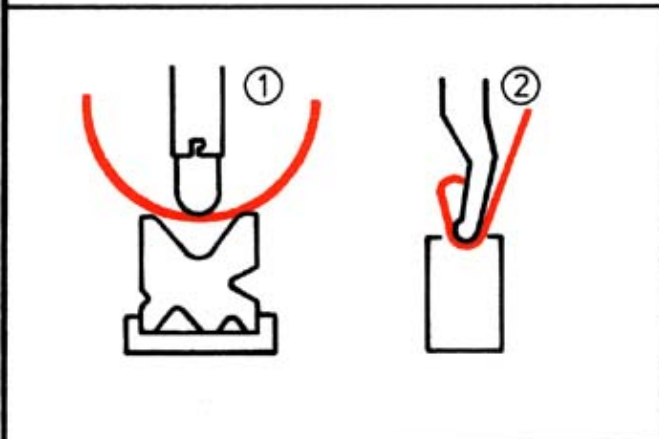

5.2

- ①
- ②

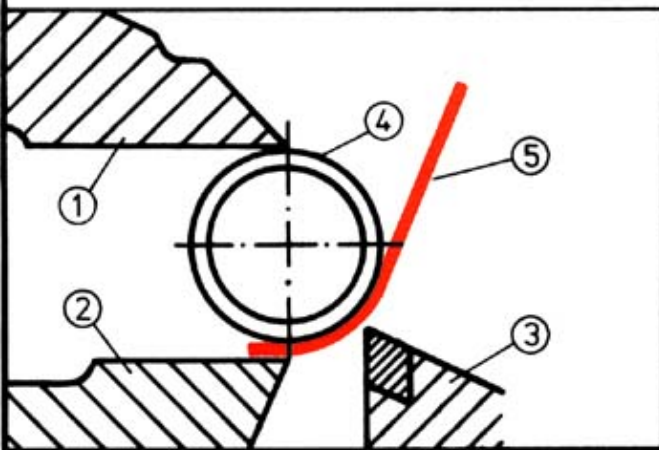

5.3

- ①
- ②
- ③
- ④
- ⑤

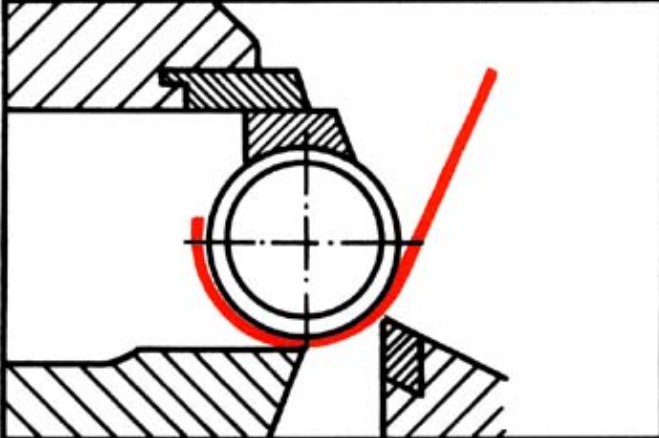

5.4



5.5



6

	<p>_____ 6.1</p>
	<p>_____ 6.2</p>
	<p>_____ 6.3</p>
	<p>_____ 6.4</p>
	<p>_____ 6.5</p>