

➔ **Cutting by Milling - Course: Techniques for machining of material. Trainees' handbook of lessons (Institut fr Berufliche Entwicklung, 17 p.)**

📄 *(introduction...)*

- 📄 1. Purpose and importance of cutting by milling
- 📄 2. Types of milling tools to be applied
- 📄 3. Preparation for cutting by milling
- 📄 4. Cutting by milling



[Home](#) > [ar.cn.de.en.es.fr.id.it.ph.po.ru.sw](#)

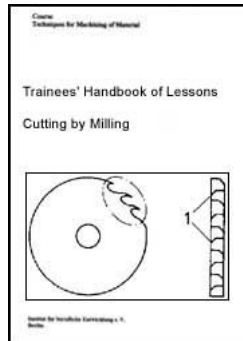

➔ **Cutting by Milling - Course: Techniques for machining of material. Trainees' handbook of lessons (Institut fr Berufliche Entwicklung, 17 p.)**

➔ *(introduction...)*

- 📄 1. Purpose and importance of cutting by milling
- 📄 2. Types of milling tools to be applied
- 📄 3. Preparation for cutting by milling
- 📄 4. Cutting by milling

**Institut fr berufliche Entwicklung e. V.
Berlin**

**Original title:
Arbeitsmaterial fr den Lernenden
"Trennfresen"**

Author: Dieter Frank

First edition © IBE

**Institut fr berufliche Entwicklung e.V.
Parkstrae 23
13187 Berlin**

Order No.: 90-35-3306/2





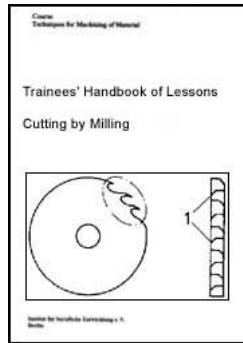

Home"" """"""> [ar.cn.de.en.es.fr.id.it.ph.po.ru.sw](#)



 **Cutting by Milling - Course: Techniques for machining of material. Trainees' handbook of lessons (Institut fr Berufliche Entwicklung, 17 p.)**

 **(introduction...)**

-   **1. Purpose and importance of cutting by milling**
-  **2. Types of milling tools to be applied**
-  **3. Preparation for cutting by milling**
-  **4. Cutting by milling**

1. Purpose and importance of cutting by milling

By cutting by milling we understand the cutting of workpiece of different geometrical forms (prismatic, rotationally symmetrical) with a metal slitting saw blade as the milling tool.

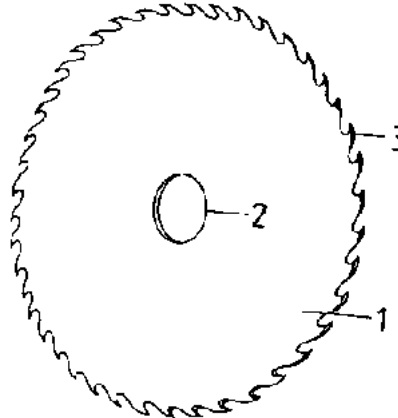

Figure 1 - Metal slitting saw blade

- 1 - backing material**
- 2 - socket**
- 3 - cutting teeth**

Moreover, we can cut workpieces being processed before in a strip shape or bar shape. For example, collar-shaped rotationally symmetrical workpieces can be cut into segments by cutting by milling. Sleeve-shaped workpieces can be applied by cutting by milling (semi-sided) as fixing bushes.

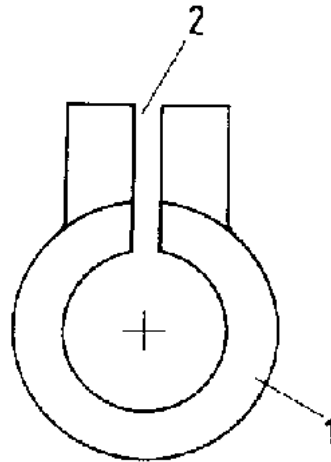

Figure 2 - Sleeve - clamp groove

- 1 - sleeve**
- 2 - clamp groove**

The processing and manufacturing of workpieces by cutting by milling is carried out for the purpose:

- to cut strips, bars, collars and sheaves of different geometrical forms and different raw material.**
- to cut bushes (semi-sided) in order to reach the clamping of the male part in the bush.**

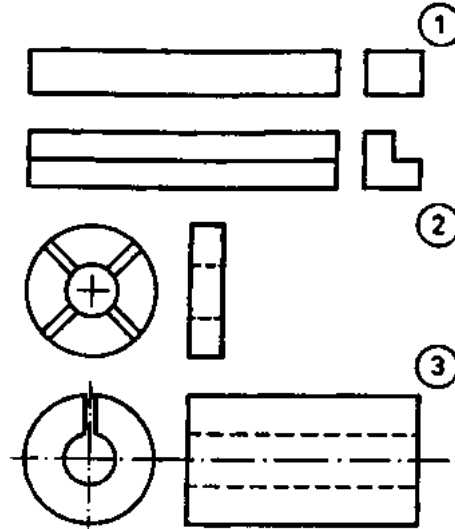

Figure 3 - Examples for cutting by milling

- (1) bar section**
- (2) collar - segments,**
- (3) sleeve - clamp groove**

- to cut (to notch or to cut out) certain parts for workpieces, such as angle strips where blacks should be bent off.

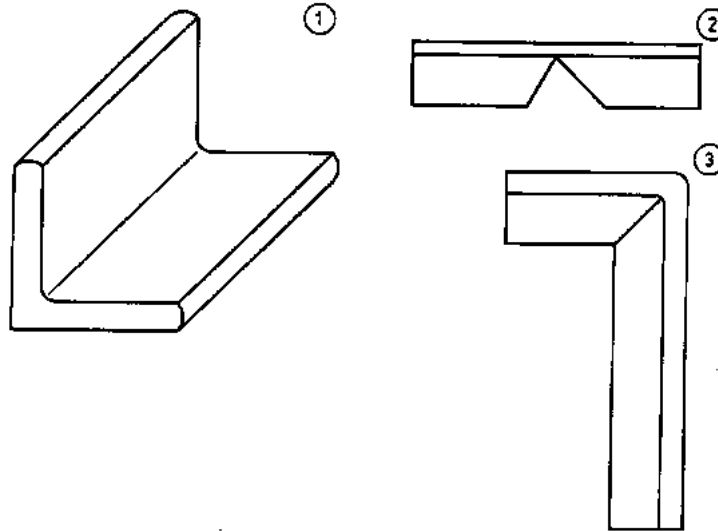

Figure 4 - Angle iron - bent

- (1) angle iron**
- (2) separation notch**
- (3) angle iron - bent**

The processing and manufacturing of workpieces by cutting by milling is mainly carried out on horizontal milling machines. In special cases cutting by milling is carried out on a vertical milling machine.

That machine is applied especially if the geometrical form of the workpiece or the part to be processed needs a vertical milling machine to be applied.

What do we understand by cutting by milling?

On what type of milling machines is cutting by milling mainly carried out?



[Home](#) > [ar](#) [cn](#) [de](#) [en](#) [es](#) [fr](#) [id](#) [it](#) [ph](#) [po](#) [ru](#) [sw](#)

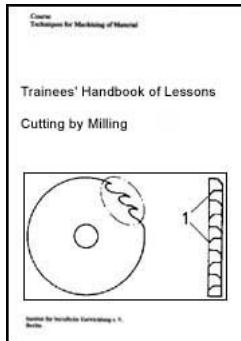

 **Cutting by Milling - Course: Techniques for machining of material. Trainees' handbook of lessons (Institut für Berufliche Entwicklung, 17 p.)**

 **(introduction...)**

 **1. Purpose and importance of cutting by milling**

 **➔ 2. Types of milling tools to be applied**

 **3. Preparation for cutting by milling**

 **4. Cutting by milling**

2. Types of milling tools to be applied

Metal slitting saw blades used for metal working, having different sizes and order of cuts are applied for cutting by milling. The metal slitting saw blades are made of super high-speed steel, The selection and application of the respective metal slitting saw blades depend on:

- **the size of the workpiece to be cut and thus the minimum diameter of the metal slitting saw blades is to be deduced.**

- **the breadth of the metal slitting saw blade from which the given cutting width is determined.**
- **the raw material of the workpiece to be cut whereby the selection of a coarse-tooth or fine-tooth metal slitting saw blade is determined.**
 - **For tough raw materials (steel and steel alloys) a relatively fine-tooth metal slitting saw blade is applied.**
 - **For brittle raw materials (e.g. grey cast iron) a coarse-tooth metal slitting saw blade is applied.**
 - **For raw materials made of light metals (e.g. aluminium and aluminium alloys) coarse-tooth metal slitting saw blades are applied.**

Concerning its constitution and construction the metal slitting saw blade is a tender milling tool. That is why you should take special care when handling and storing metal slitting saw blades. In the metal processing industry metal slitting saw blades being applied on milling machines of the following allowances are used having a

- **width from 0.6 up to 6.0 mm, and a**
- **diameter from 50.0 up to 300.0 mm.**

With the outer dimensions of the metal slitting saw blades (width and diameter) also the socket for the clamping means is changed. The sockets of the metal slitting saw blades refer to the standardized diameter of the cutter arbor which is used as clamping means.

The metal slitting saw blade refers in its basic form to the typical form of a cylinder as all milling tools. Only because of its width it gets the form of a very flat cylinder, a sheave. The flat sides of the metal slitting saw blades are hollow ground towards their centre to

prevent a "fixing" (risk of breakage) in the workpiece during cutting by milling.

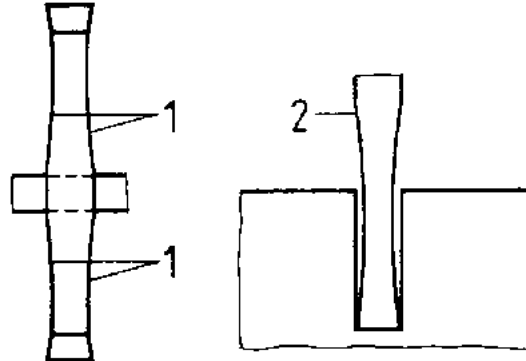

Figure 5 - Metal slitting saw blade

1 - lateral hollow grinding,

2 - metal slitting saw blade in the workpiece (enlarged hollow grinding)

The hollow grinding serves to reduce the occurring friction during the cutting process.

The cutting teeth are situated only upon the periphery of the metal slitting saw blade and are reciprocally provided with a bevel.

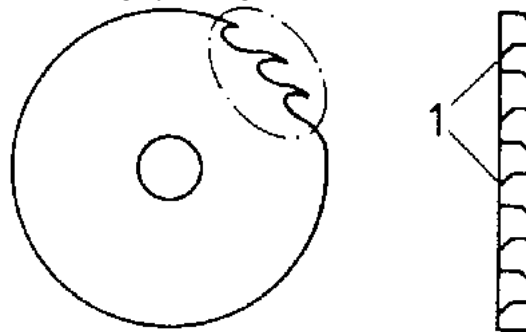

Figure 6 - Metal slitting saw blade

1 - reciprocal bevel grinding

Contrary to other milling tools the metal slitting saw blade has no slot for the feather key of the cutter arbor in its socket.

The connection between the cutter arbor and the metal slitting saw blade, i.e. the transmission of the torque is flexible.

The feather key slot to be found in other milling tools is not present because of the small width of the metal slitting saw blades and the notch effect and the weakening of the cross section by the slot. In order to secure the metal slitting saw blade on the cutter arbor (long arbor) a feather key is placed into one of the arbor rings in the space between the metal slitting saw blade and the arbor bearing sleeve of the end support.

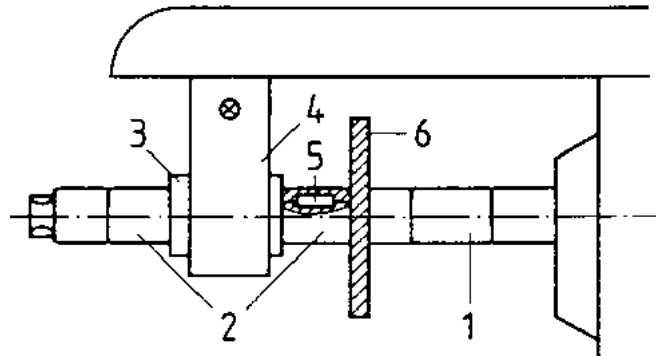

Figure 7 - Fastening of the metal slitting saw blade

- 1 - cutter arbor,**
- 2 - arbor rings,**
- 3 - arbor bearing sleeve,**
- 4 - end support,**
- 5 - feather key,**
- 6 - metal slitting saw blade**

With the application of a short cutter arbor the feather key is placed into an arbor ring between the metal slitting saw blade and the cross worm.

With the application of metal slitting saw blades of a large diameter the fixing of chuck flanges is recommended. They reduce occurring vibrations and provide a guide to the metal slitting saw blade.

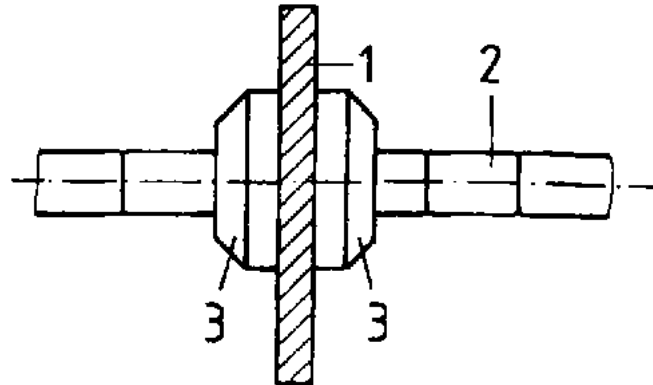
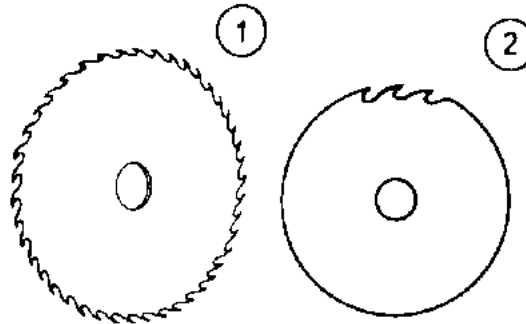

Figure 8 - Chuck flanges

- 1 - metal slitting saw blade
- 2 - cutter arbor
- 3 - chuck flanges

There are manufactured coarse-tooth and fine-tooth metal slitting saw blades.



- (1) coarse-tooth,**
- (2) fine-tooth**

The coarse-tooth metal slitting saw blades are applied for the cutting by milling of workpieces made of

- **aluminium, copper, steel, having**
- **a tensile strength of less than 600 MPa, and for**
- **non-metallic raw materials.**

The fine-tooth metal slitting saw blades are mainly applied for

- **steel, having**
- **a tensile strength of more than 600 MPa**
- **thin-walled workpieces**
- **angle sections, sheet metal**
- **tough raw materials.**

Which milling tools are applied for cutting by milling?

What types of metal slitting saw blades for cutting by milling are available?

For what purpose are the metal slitting saw blades hollow ground at their sides?



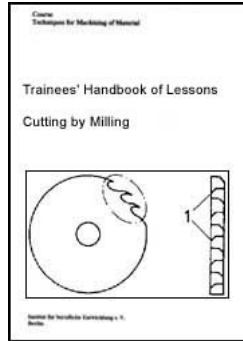

 **Cutting by Milling - Course: Techniques for machining of material. Trainees' handbook of lessons (Institut für Berufliche Entwicklung, 17 p.)**

 **(introduction...)**

 **1. Purpose and importance of cutting by milling**

 **2. Types of milling tools to be applied**

 **➔ 3. Preparation for cutting by milling**

 **4. Cutting by milling**

3. Preparation for cutting by milling

For the preparation of this technique you need to do the following:

- **mental planning of the sequence of operations like**
 - **the selection of the milling machine to be applied (horizontal or vertical milling machine)**
 - **the selection of the metal slitting saw blade to be used (coarse-tooth or fine-tooth; diameter and width)**
 - **the selection of the clamping means**
 - **selection of the measuring and testing means**
 - **the technological process (sequence of operations) of cutting by milling**

- **arrangement of the necessary tools, measuring and testing means as well as the auxiliaries paying attention to the basic principles of their proper storage and safe position.**
- **checking the functioning and the functional safety of the milling machine, the tools and the auxiliaries to be applied. Reject worn out tools immediately!**

The lubrication of the milling machine and the oil-level check should be carried out according to the lubrication schedule.

Clamping of the workpieces for milling

For cutting by milling mainly such clamping means are applied which are used when milling on horizontal and vertical milling machines, e.g.:

- **machine vice**
- **direct clamping on the machine table, and on the**
- **rotary table**
- **special clamping means.**

The clamping of the workpieces can be carried out depending on their geometrical forms and their dimensions in a single-piece or multi-piece clamping (package clamping). When applying machine vices, clamping jaws are often used for cutting by milling.

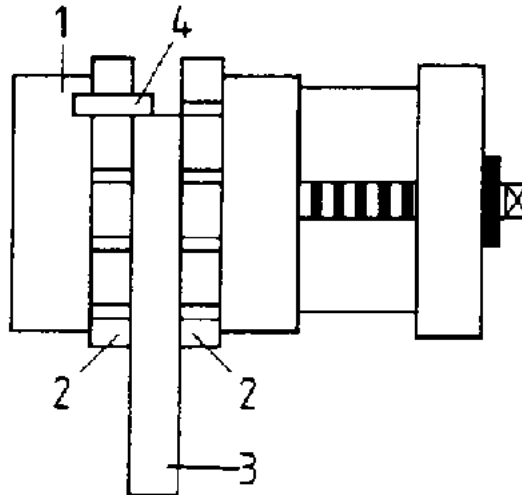

Figure 10 - Separating jaws

- 1 - machine vice**
- 2 - separating jaws**
- 3 - workpiece**
- 4 - stop**

For an exact adjustment of the clamping means the localization should be carried out according to the accuracy requirements by means of tongues, stop bars, stops and other auxiliaries, including dial gauge/bevelled edge square.

Clamping means (clamp iron, lock screws) should be fixed on those parts where the cutting by milling is not impaired (space for the milling tool and the clamping means).

In order to constantly reach the required space and length dimensions, suitable stops (stop jacks, stop bars) are to be fixed for a clear localization of the workpieces.

When using workpiece clamping means you should pay attention that no changes on the workpiece supporting and bearing surfaces are carried out. Before the fixture's clamping on the machine table or on the rotatory table the ground spaces of the fixture should be cleaned by all means.

When clamping the workpieces you should pay attention to burr-freeness and cleanliness of the bearing and working faces in any case. Uncleanliness and burrs lead to a positional deviation while clamping. The results are quality flaws and damages (flaws) on the surface of the workpiece.

Handling sharp-edged workpieces and tools you should wear safety gloves to avoid cuts on your hands. The deburring of the workpieces should be carried out only with proper files.

Clamping of the tools for cutting by milling

For the fastening and the setting-up of the clamping means (long and short cutter arbors) only proper clamping tools (spanner and cross spanner) should be used. Irrespective of the clamping means to be applied the labour safety requirements should be taken into account:

For deburring the workpieces before clamping or before measuring and testing only proper files should be used! Sharp-edged workpieces and milling tools should be moved with safety gloves or a suitable rag to avoid cuts on your hands!

Selection and application of the measuring and testing means

For measuring and testing the workpieces (dimensional and positional deviations) you should use:

- a vernier caliper
- a steel square/bevelled edge square
- a depth gauge
- a universal bevel protractor (for workpieces with bevelled surfaces)

Before measuring and testing the workpieces should always be deburred and cleaned.

Only functioning measuring and testing means should be applied. Damaged measuring and testing means should not be used and immediately be sent on for repair or be removed.

The durability of the measuring and testing means does depend on a proper positioning and storing at the workplace and on a careful handling. Damaged measuring and testing means should not be used. They should be sent on for checking and repair or be removed. Which clamping auxiliaries should be used with cutting by milling if the clamping of the workpieces is carried out in machine vices?

What should you always consider when clamping, or measuring and testing the workpieces?



[Home](#)''' '''> [ar.cn.de.en.es.fr.id.it.ph.po.ru.sw](#)



Cutting by Milling - Course: Techniques for machining of material. Trainees' handbook of lessons (Institut fr Berufliche Entwicklung, 17 p.)

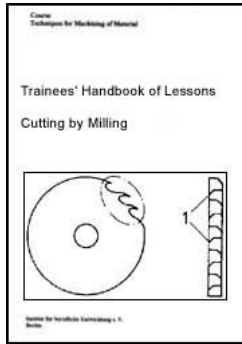

(introduction...)

1. Purpose and importance of cutting by milling



2. Types of milling tools to be applied



3. Preparation for cutting by milling



4. Cutting by milling

4. Cutting by milling

Before cutting the workpieces delivered as bar stock material, one side of the bar should be processed by end milling. Thereat the cutting depth should be chosen so that with a least chip removal the end face will be clean milled. By means of the end milling, a workpiece cut-off (loss of material) is not necessary. The end milling should be carried out on all delivered bars by means of multi-piece clamping on a horizontal milling machine. With the cutting by milling of rotationally symmetrical (cylinder-shaped) workpieces prism slide jaws (prism slide lengthwise) for the clamping in a machine vice are applied.

In some cases the cutting by milling is also carried out after marking. This is done mainly at workpieces where, after cutting by milling, surfaces are resulting being not in an angle of 90° to the reference face. So they have no parallel faces to the opposite face either. These workpiece shapes do often result from cutting by milling of collars in the form of different segments.

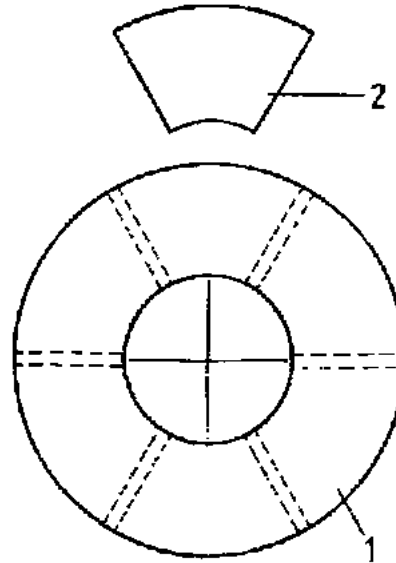

Figure 11 - Cutting after marking

1 - workpiece with marking

2 - segments

The fixing (localization) of workpieces after marking is done by means of a marking gauge where the working face is slid along the face of the machine table or e.g. also along the glide path of the machine stand by hand.

Because of their small cross section metal slitting saw blades are tender milling tools:

- A too high speed of rotation leads to a premature dulling (wear) and so to a

degeneration of the surface quality of the workpieces.

- A further application of dull metal slitting saw blades can lead to a "standstill" during the cutting process and so to a breakage of the metal slitting saw blade. By a "standstill" of the metal slitting saw blade we do understand the situation when at a working table feed in the working direction and the cutter arbor rotating, the metal slitting saw blade is not moving any longer. This situation can be explained by a non-positive connection, not a positive one as usual with other milling tools.

- The application of metal slitting saw blades of a larger diameter (250 to 300 mm) can lead to the untrue running of the metal slitting saw blade. This means that the metal slitting saw blade is pushed away during the cutting process sideways because of its' small cross section.

This results in uneven and non-angular or non-parallel surfaces on the workplace. Moreover, the risk of breaking (breakage) of the metal slitting saw blade is increased. In order to counteract this with the application of metal slitting saw blades of larger diameter and smaller width chuck flanges are fastened on both sides of the metal slitting saw blade (see figure 8).

The setting-up of the milling machine to carry out the technique cutting by milling is done according to the following sequence of operations:

- Checking the completeness and functioning of the milling machine, of the clamping means and auxiliaries to be applied, oil-level check and lubrication of the milling machine to be carried out according to the lubrication schedule's cycle.

- Arrangement of the necessary measuring and testing means at the workplace on a suitable soft base.

- **Chucking and fixing of the clamping means.**
- **Setting-up and clamping in or on the workpiece (workpiece support, length feed stop).**
- **Fixing the coolant system when processing workpieces made of steel.**
- **Installing of the milling protective system.**
- **Clamping in the cutter arbor and clamping on the metal slitting saw blade. Do not forget the feather key in one of the arbor rings!**
- **Positioning of the milling machine table into the appropriate processing position to the milling tool (X-Y-Z-direction).**
- **Fixing the cutting values (speed of rotation, feeding speed) according to the indications given on the nomogram or in a table for the appropriate milling machine. The cutting depth at cutting by milling corresponds to the width or height or the workpiece.**
- **Cutting by milling is carried out as conventional milling. The plunge milling is applied only in exceptional cases. Cutting by milling of non-metallic raw materials (e.g. plastics) as down-cut milling is applied very seldom, too.**
- **Cutting in (a small groove in the workpiece) at the rotating metal slitting saw blade. Table feed back and make a dimensional inspection of the workpiece in the fastened condition. If necessary, correct with manual adjustment of the head.**
- **Continuation of cutting by milling using a strong jet of cooling water directed on the place of the cutting by milling.**

- **Clamping out, deburring and cleaning of the workpiece, linear measure control and control of the angularity and surface finish.**
- **If necessary, make corrections on the localization of the workpiece or the clamping means, and on the linear or space measures to the reference face.**
- **With the change of the workpieces you should meet the requirements of a proper clamping of the workpieces (burr-freeness, cleanliness of the workpiece supporting and bearing surfaces).**

Permanent control of the workpiece on adherence to the quality requirements secures a continuous production process and helps to avoid rejects (uselessness of the workpieces).

- **Ending up with the technique of cutting by milling you should clean the milling machine, all tools used, auxiliaries and the whole workplace. The used metal slitting saw blades are sent on to be resharpened (sharpen).**

What is the task of the feather key in one of the arbor rings between the metal slitting saw blade and the arbor nut?

What are workpieces with a marking fixed with for cutting by milling?

Which milling process is usually applied on cutting by milling?

What is the purpose of "clean milling" of bar stock material at one end face before cutting by milling?

What is always necessary at the end of cutting by milling?

