

[Home](#) > [ar.cn.de.en.es.fr.id.it.ph.po.ru.sw](#)

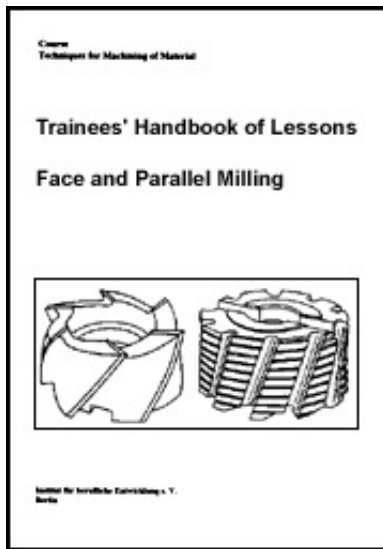

➔ **Face and Parallel Milling - Course: Techniques for machining of material. Trainees' handbook of lessons (Institut für Berufliche Entwicklung, 21 p.)**

📄 **(introduction...)**

- 📄 **1. Purpose and importance of face and parallel milling**
- 📄 **2. Kinds of milling tools to be employed**
- 📄 **3. Preparing face and parallel milling**
- 📄 **4. Face milling**
- 📄 **5. Parallel milling**



[Home](#) > [ar.cn.de.en.es.fr.id.it.ph.po.ru.sw](#)

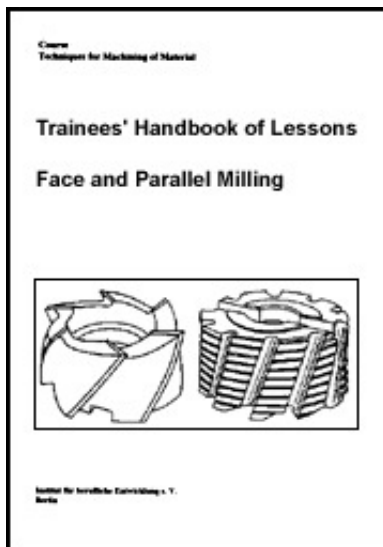

📖 **Face and Parallel Milling - Course: Techniques for machining of material. Trainees' handbook of lessons (Institut für Berufliche Entwicklung, 21 p.)**

➔ 📄 **(introduction...)**

- 📄 **1. Purpose and importance of face and parallel milling**
- 📄 **2. Kinds of milling tools to be employed**
- 📄 **3. Preparing face and parallel milling**
- 📄 **4. Face milling**
- 📄 **5. Parallel milling**

**Institut fr berufliche Entwicklung e. V.
Berlin**

**Original title:
Arbeitsmaterial fr den Lernenden
"Frser von Plan- und Parallelfchen"**

Author: Dieter Frank

First edition © IBE

**Institut fr berufliche Entwicklung e.V.
Parkstrae 23
13187 Berlin**

Order No.: 90-35-3302/2



[Home](#) > [ar](#).[cn](#).[de](#).[en](#).[es](#).[fr](#).[id](#).[it](#).[ph](#).[po](#).[ru](#).[sw](#)

 **Face and Parallel Milling - Course: Techniques for machining of material. Trainees' handbook of lessons (Institut fr Berufliche Entwicklung, 21 p.)**

 **(introduction...)**

-   **1. Purpose and importance of face and parallel milling**
-  **2. Kinds of milling tools to be employed**

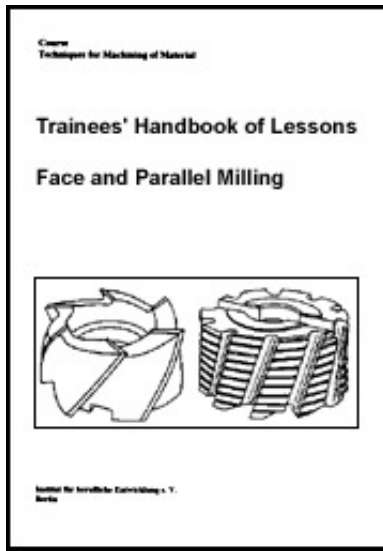

3: Preparing face and parallel milling



4: Face milling

5: Parallel milling

1. Purpose and importance of face and parallel milling

Face and parallel milling is predominantly applied in the machine and plant building industry.

Plane and parallel surfaces can be milled within the manufacturing process of milling on horizontal or vertical milling machines .

To produce plane and parallel surfaces, the milling processes of plain and face cutting are applied by using up-cut milling and climb-cut milling.

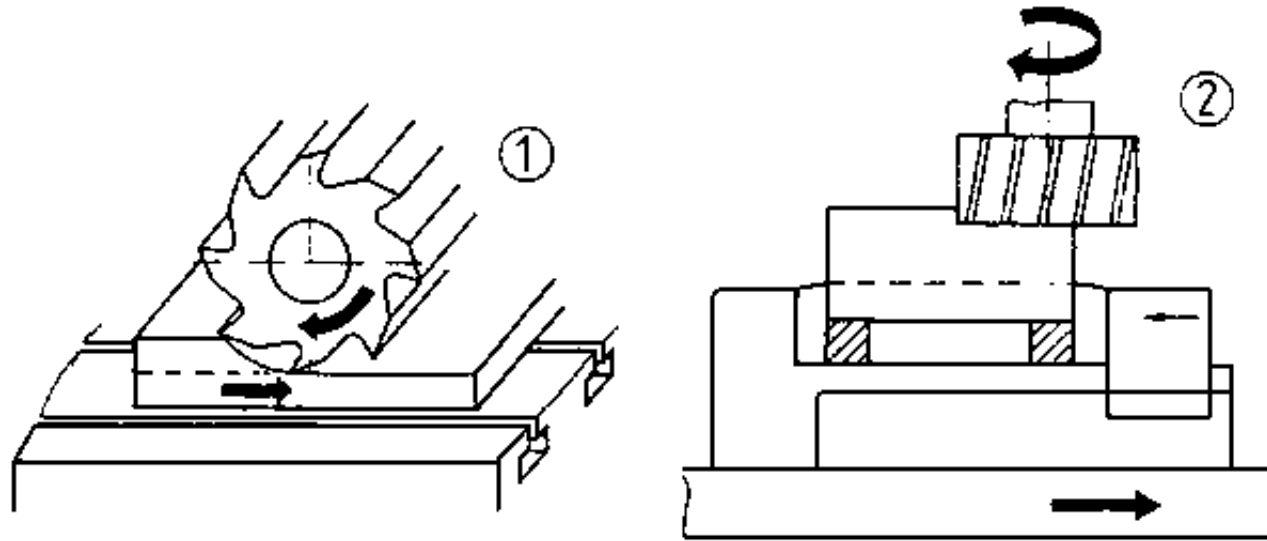

Figure 1 Plain and face milling

(1) plain milling, (2) face milling

Plane surfaces are those being even after the surface has been machined (e.g. by milling). A surface is plane (even) when in a light gap test method with a bevelled steel edge the latter lies uniformly on all places of the surface.

Parallel surfaces are those lying opposite to one another and running in the same direction. Parallel surfaces have an equal distance to one another at all points. Surfaces can only be parallel to one another, when they are plane as well.

What are plane surfaces?

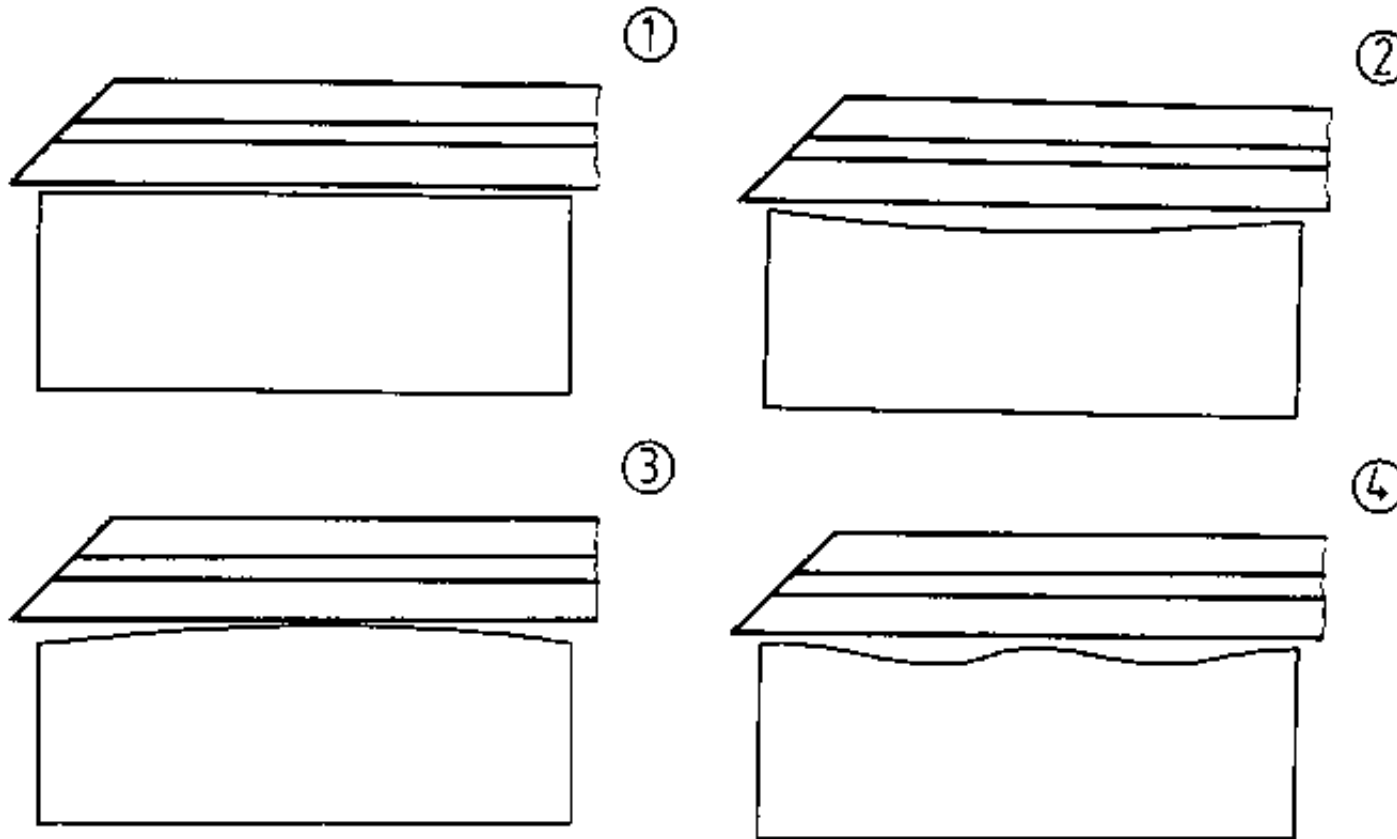

Figure 2 Test illustrations

(1) surface is plane, (2) surface is concave, (3) surface is convex, (4) surface is "twisted"

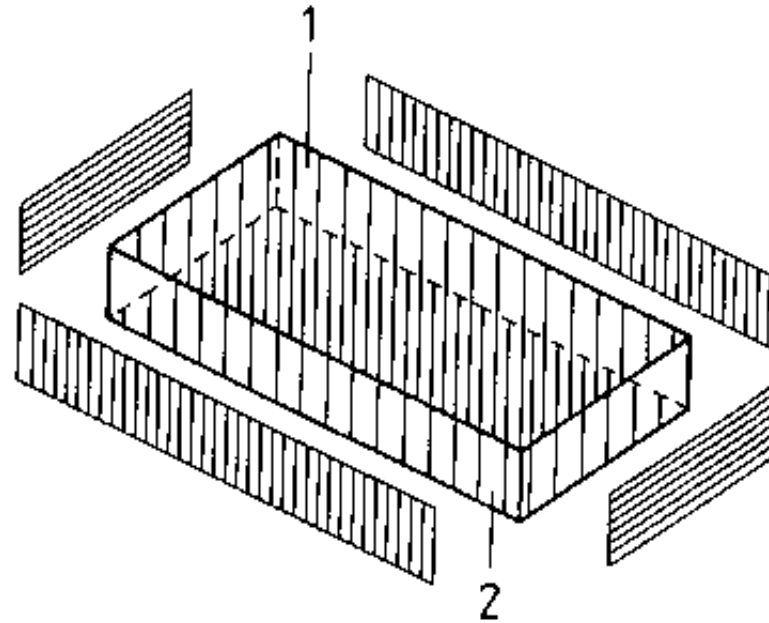

Figure 3 Parallel surface

**1 surface parallel to base surface,
2 parallel surface (longitudinal sides)**

What are parallel surfaces?

As for milling of plane surfaces on horizontal or vertical milling machines the face milling process has proved more economical compared to plain milling. As far as face milling is concerned, carbide-tipped milling tools (milling heads/face milling cutters) are mainly used, which allow higher cutting values (speed/cutting speed and rate of feed). In case of plain milling with plain milling cutters, the cutting width cannot be wider than the cutter. Cutting width in plain milling is limited by

the cutter width.

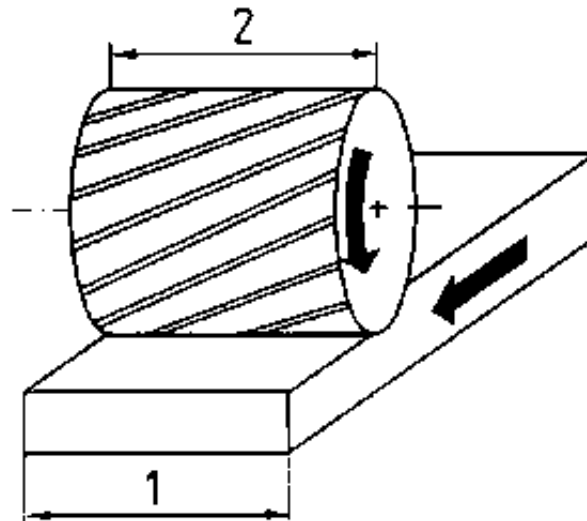

Figure 4 Milling width

**1 workpiece width,
2 milling cutter width**

Parallel surfaces may be milled:

- by individual machining (requires the workpiece to be clamped twice)
- by gang mill cutters (simultaneous machining by gang mill cutters of the surfaces running in parallel)

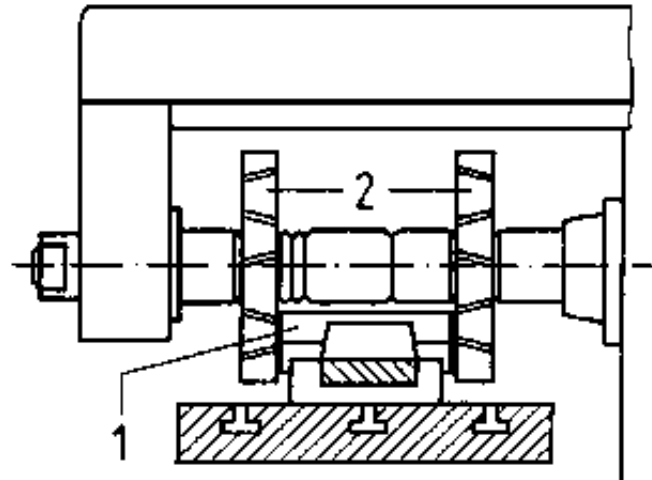

Figure 5 Gang mill cutter

**1 workpiece,
2 gang mill cutter (2 side milling cutters)**

- on two-spindle bed-type milling machines or double- column planer-type milling machines (simultaneous machining of parallel surfaces by employing two or more milling spindles)

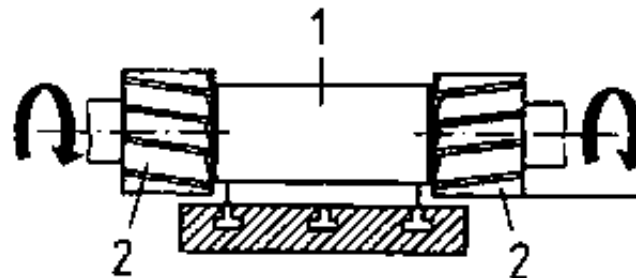
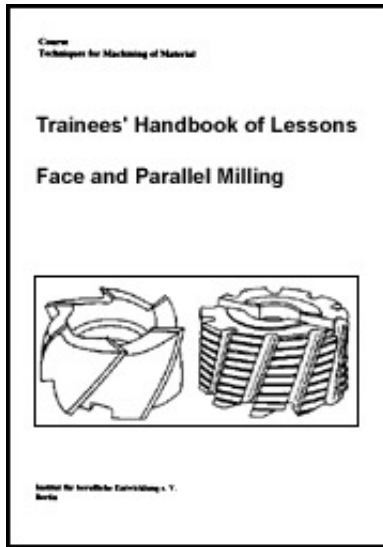



Figure 6 Two-spindle milling cutter

1 workpiece, 2 milling cutter (2 cutter spindles)



[Home](#) > [ar](#).[cn](#).[de](#).[en](#).[es](#).[fr](#).[id](#).[it](#).[ph](#).[po](#).[ru](#).[sw](#)



 **Face and Parallel Milling - Course: Techniques for machining of material. Trainees' handbook of lessons (Institut fr Berufliche Entwicklung, 21 p.)**

 **(introduction...)**

 **1. Purpose and importance of face and parallel milling**

  **2. Kinds of milling tools to be employed**

 **3. Preparing face and parallel milling**

 **4. Face milling**

 **5. Parallel milling**

2. Kinds of milling tools to be employed

Milling tools are multi-edged tools having edges that have been determined geometrically. They consist of super-speed steel or carbide, or have edges that are carbide-tipped.

In exceptional cases, single-point cutting tools are employed, e.g. in fly-cutting.

During the milling operation the milling tool makes a rotating main motion (revolving motion), while the workpiece moves straight (feed motion).

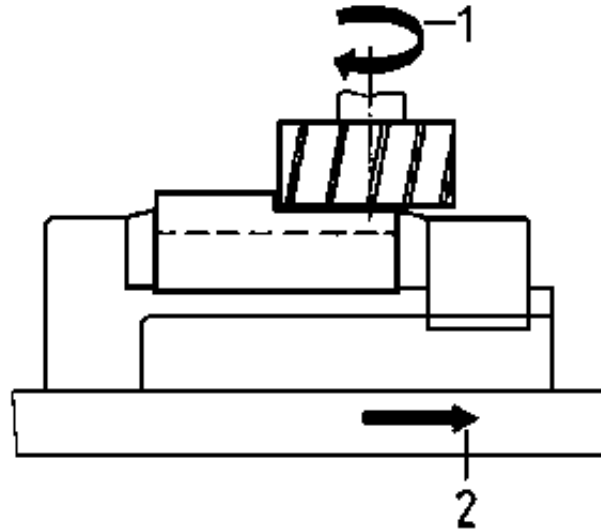

Figure 7 Main and auxiliary motions during milling

**1 revolving motion of the milling cutter (main motion),
2 feed motion of the workpiece (auxiliary motion)**

Milling tools are basically differentiated according to the configuration of edges.

Milling cutters that have edges exclusively at the circumference (peripheral) surface of their cylindrical body are called "plain milling cutters".

Milling cutters that have edges at the circumference and at one face side are called end face milling cutters.

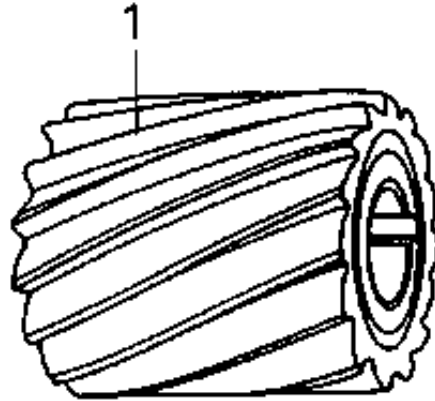

Figure 8 Plain milling cutter

1 circumferential cutting edges

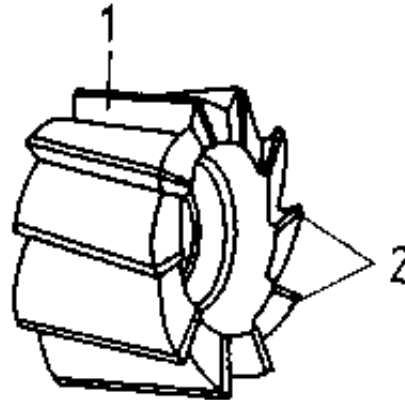
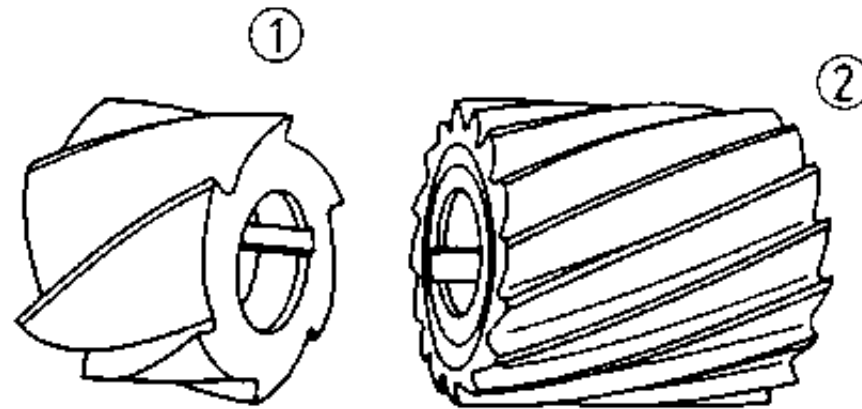

Figure 9 Plain and face milling cutter

1 circumferential cutting edges, 2 face cutting edges

With regard to the planned kind of application - rough cutting or finish-cutting - the plain and face milling cutters are furthermore distinguished. There are rough-geared and fine-geared milling cutters as well as milling cutters for light-metal

and steel machining.**Figure 10 Plain rough-geared**

**(1) rough-geared,
(2) fine-geared**

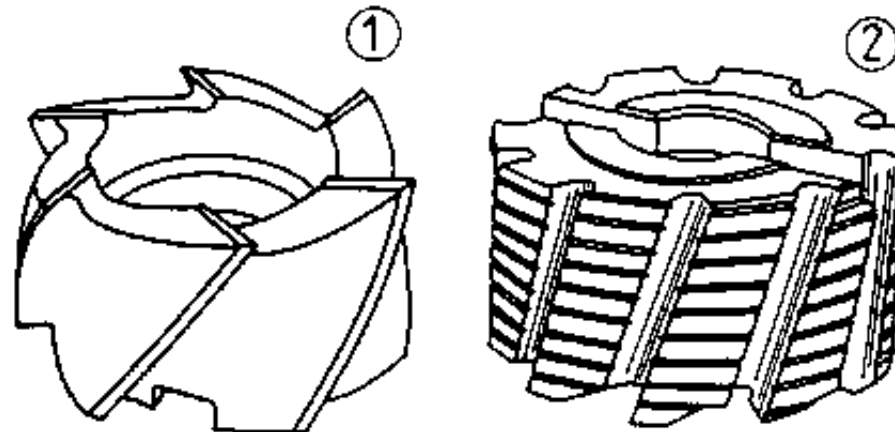
**Figure 11 Plain and face milling cutter**

**(1) for machining light metal,
(2) for machining steel**

Another kind of milling cutters equipped with circumferential and face cutting edges are those milling cutters having soldered, inserted or changeable carbide tips.

They make higher cutting values possible, inclusive of a saving of high-grade cutting materials and the changeability of spent or damaged carbide tips.

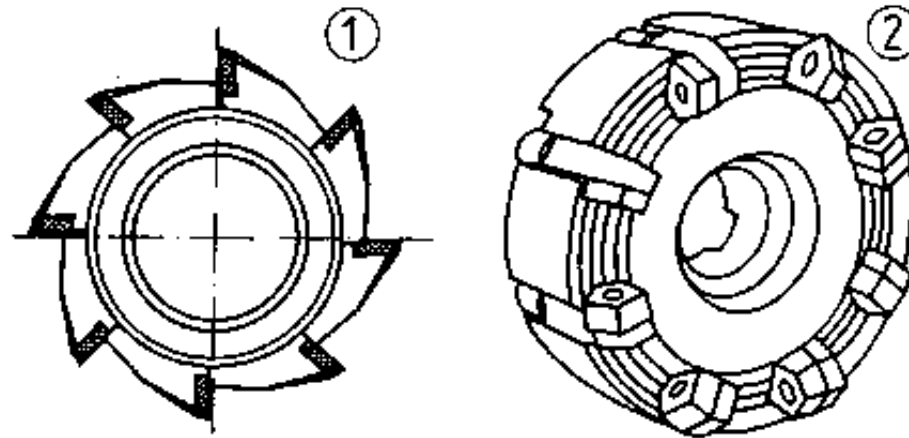

Figure 12 Carbide-tipped milling cutters

(1) with soldered carbide tips

(2) with changeable reverse carbide tips

To machine plane and parallel surface with bigger sizes (surface width from 150 mm onwards), face milling heads (face milling cutters) fitted with various reverse cutting tips are employed. According to the kind of material of the workpieces to be machined, reverse cutting tips for machining steel, cast steel and cast iron are used.

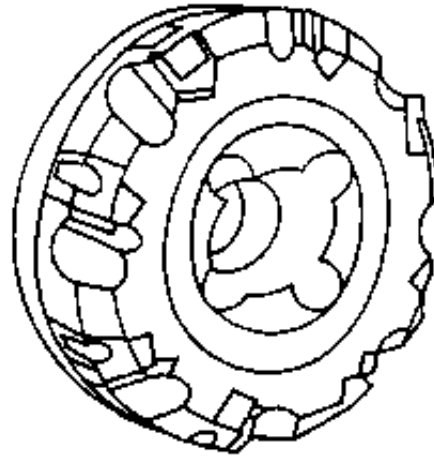

Figure 13 Face milling head (face milling cutter) with reverse tips

With regard to the simultaneous machining of parallel surfaces, milling tools are mainly combined (coupling and gang mill cutters) that consist of two or several side milling cutters, plain or face milling cutters or a suitable combination of these milling cutters.

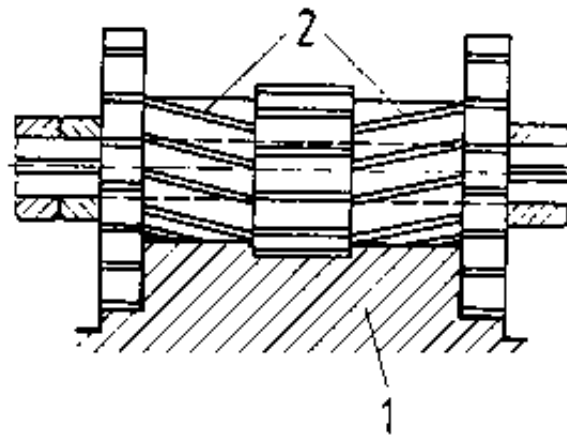

Figure 14 Gang mill cutter

1 workpiece section, 2 gang mill cutter (consisting of 2 side milling cutters, 3 plain milling cutters - 2 of them with same diameter)

Thus, there is the possibility to combine several individual working steps in one work-holding fixture at the same time. So, an economic machining of parallel surfaces is possible, since the combination of individual working steps reduces the time required. Moreover, a high quality (accuracy) of parallelism of the surface milled is achieved.

Which kinds of milling tools are suited for machining plane surfaces?

What are the possibilities of milling parallel surfaces?

As to which points of view are milling tools selected?

By which possibilities can two and several parallel surfaces be machined at the same time?



[Home](#)"" """"> [ar](#).[cn](#).[de](#).[en](#).[es](#).[fr](#).[id](#).[it](#).[ph](#).[po](#).[ru](#).[sw](#)

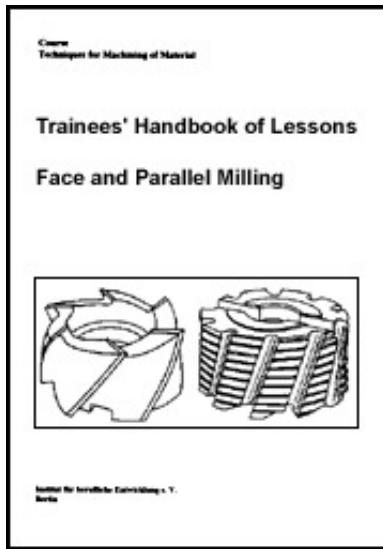

 **Face and Parallel Milling - Course: Techniques for machining of material. Trainees' handbook of lessons (Institut für Berufliche Entwicklung, 21 p.)**

 **(introduction...)**

 **1. Purpose and importance of face and parallel milling**

 **2. Kinds of milling tools to be employed**

 **→ 3. Preparing face and parallel milling**

 **4. Face milling**

 **5. Parallel milling**

3. Preparing face and parallel milling

To prepare face and parallel milling, the following activities have to be done:

- Mental planning of the course of activities**
- Selecting the milling machine (horizontal or vertical miller)**
- Selecting the required measuring and testing tools.**
- Making available necessary tools, auxiliaries as well as measuring and testing tools, considering proper depositing and storage (note the labour safety regulations')**

Use serviceable tools only, otherwise a fabrication as to good quality and labour safety is not ensured.

Attention!

- **Hammer and file handles must be undamaged and solidly stick to their seats.**
- **Tightening keys must not be worn, and their key width has to correspond to the size of clamp bolts and nuts.**

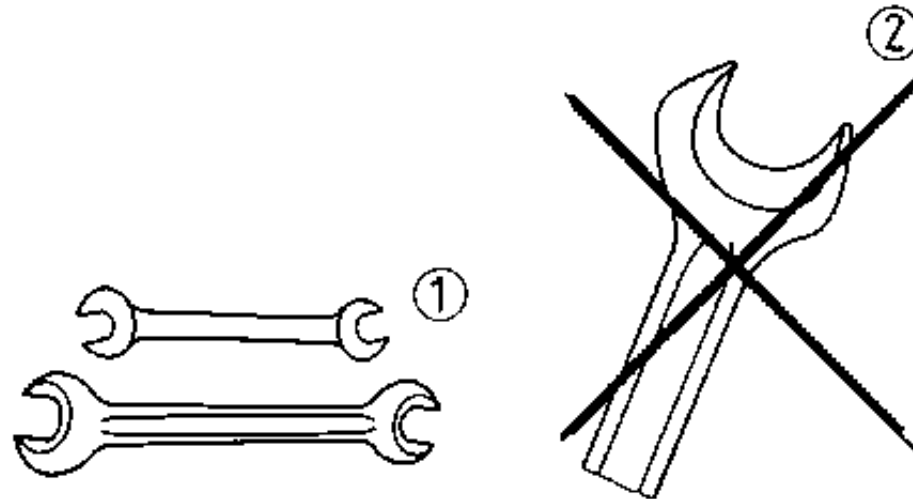

Figure 15 Fixed spanner

- (1) proper condition,
- (2) worn condition

- **Cleanliness between clamping surfaces of the work-holding fixture (e.g. machine vice) and the machine table is an essential prerequisite to obtain a good accuracy of the workpiece.**

Uncleanliness (chips) or damaged contact surfaces lead to deviations in positioning the clamping fixture and thus, to deviations in size, form and position of the workpiece. Reduction of quality, rework or uselessness of the workpiece

are the consequence.

Clamping of workpieces for milling

Number of workpieces and their geometrical form determine the kind of workholding fixture - whether single or multi-piece clamping -, the employment of clamping fixtures and other clamping auxiliaries.

- For face milling on a horizontal milling machine, the workpieces (prismatic form) are clamped in the machine vice.

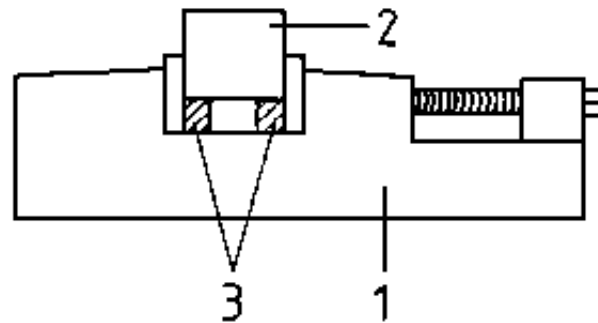

Figure 16 Machine vice

1 vice, 2 workpiece, 3 parallel piece as base

Larger workpieces are directly clamped on the machine table. The machine vice is to be aligned on the machine table for an exact positioning and accordingly tightened to secure the position .

Alignment is accomplished by:

- Sliding blocks, and in case of higher accuracy requirements, by
- front lay gauges or parallel pieces and dial gauge.

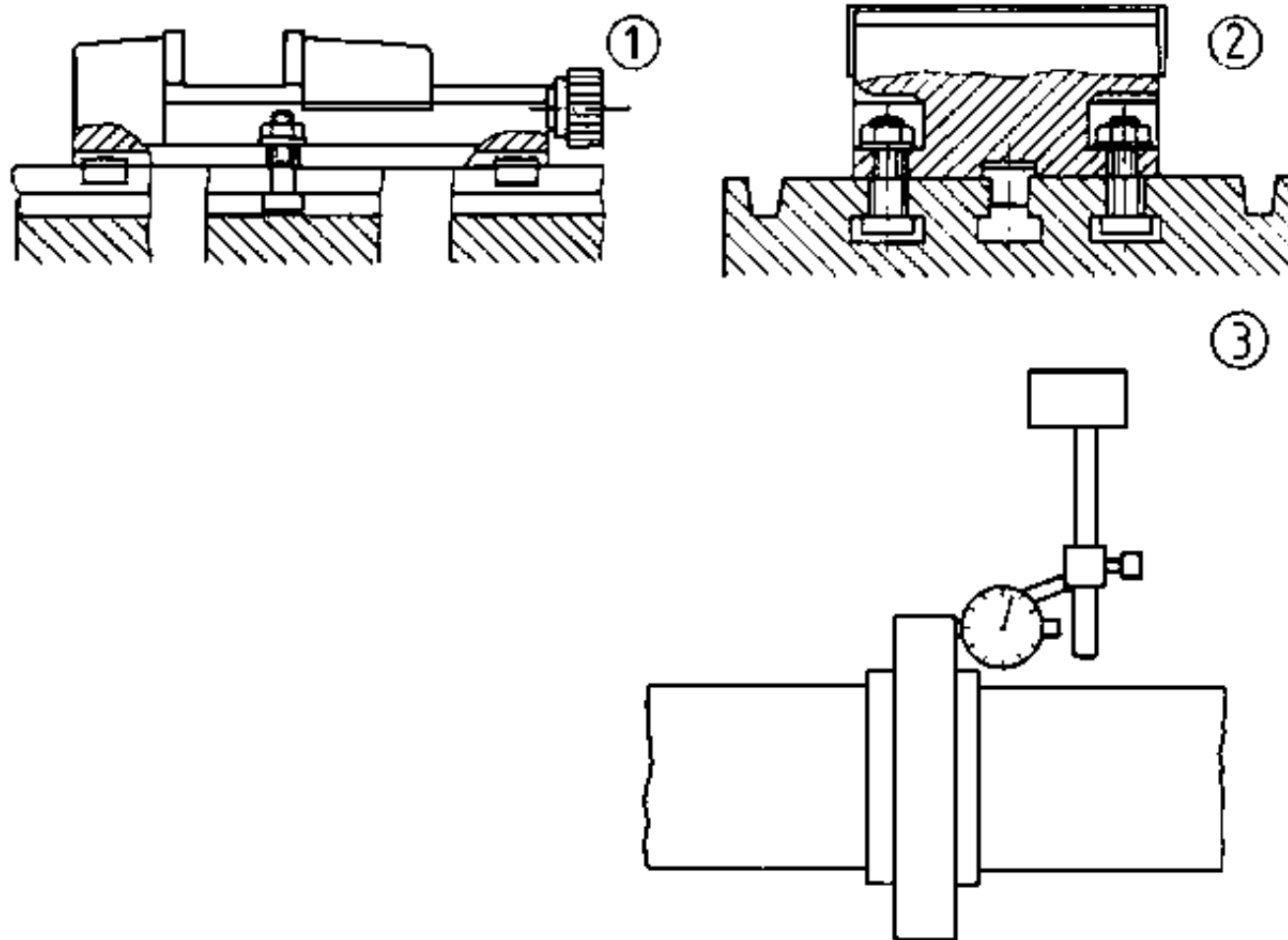

Figure 17 Workpiece positioning when machine vice is used (alignment)

- (1) with sliding blocks,
- (2) with sliding blocks,
- (3) with dial gauge and parallel pieces

Why are cleanliness and freedom of burrs absolutely to be taken into consideration when clamping workpieces?

The workpiece should be clamped in the machine vice as shortly as possible above the clamping jaws to prevent the workpiece from being torn out or from changing its position during the milling operation.

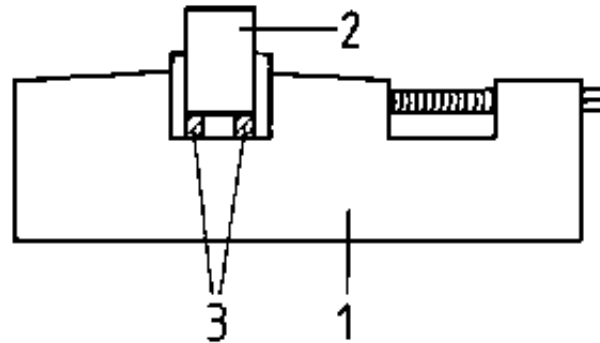

Figure 18 Clamping the workpiece in the machine vice

1 vice, 2 workpiece. 3 parallel pieces

The following work-holding fixtures are used essentially for milling parallel surfaces:

- Machine vice
- Magnetic chuck
- Direct clamping on table
- Clamping fixtures (single and multi-piece clamping)

When clamping the workpieces in the machine vice for milling parallel surfaces it is absolutely necessary to place the contact surfaces on ground parallel pieces. The following prerequisites have to be fulfilled:

- The grade of parallelism depends on the planeness of the surface worked first.**
- The workpiece has to be clean (free from chips) and deburred.**
- The exact workpiece rest can be checked by the tight seat of the parallel pieces.**
- Same height of parallel pieces is necessary.**

The following prerequisites are to be considered when work-pieces are clamped and milled on a magnetic chuck:

- The surface machined first must be clean, deburred and plane. It serves as contact and reference surface.**
- To secure the workpiece position, fences having at least 2/3 of the workpiece height must be available.**
- The depth of cut must not exceed a maximum of 2.5 mm.**
- Contact surface width must at least correspond to the height of the workpiece.**
- Only ferriferous workpieces (steel and cast materials) are permitted to be machined on the magnetic chuck.**

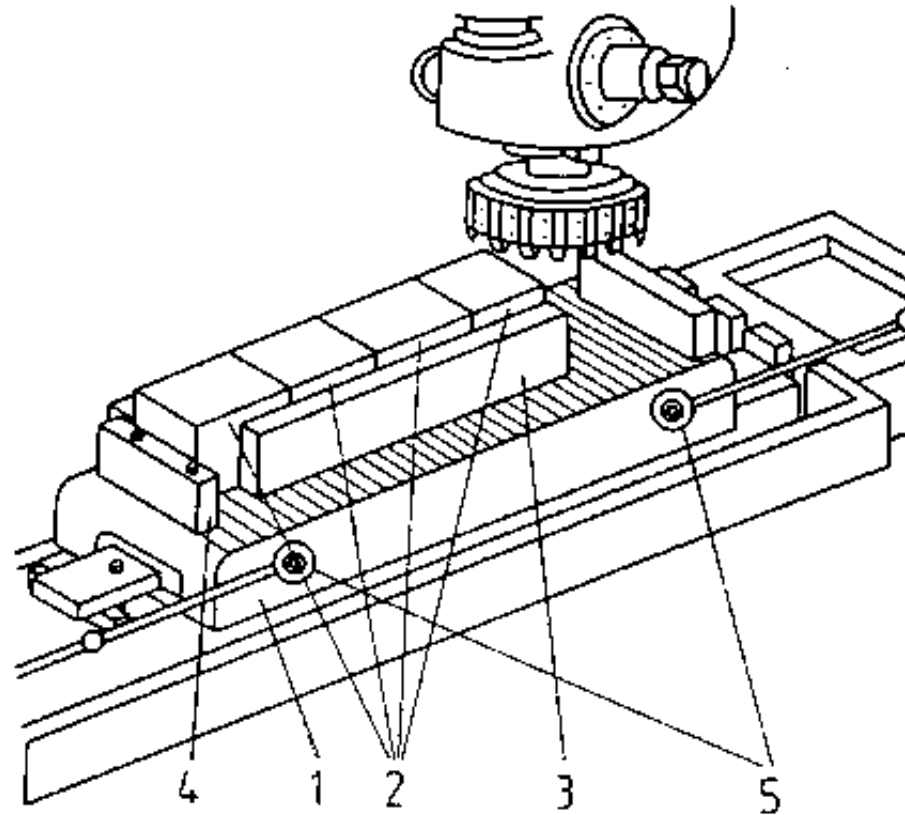

Figure 19 Clamping on magnetic chuck

- 1 magnetic chuck**
- 2 workpieces**
- 3 parallel pieces, 4 fence**
- 5 operating elements**

Due to the geometrical form or the workpiece size, direct clamping on the milling machine table is used as well.

In this case, clamping fixtures are employed in the form of clamping bolt,

clamping iron and clamping base as well as special auxiliaries (stop rails, work-holding plates, etc.).

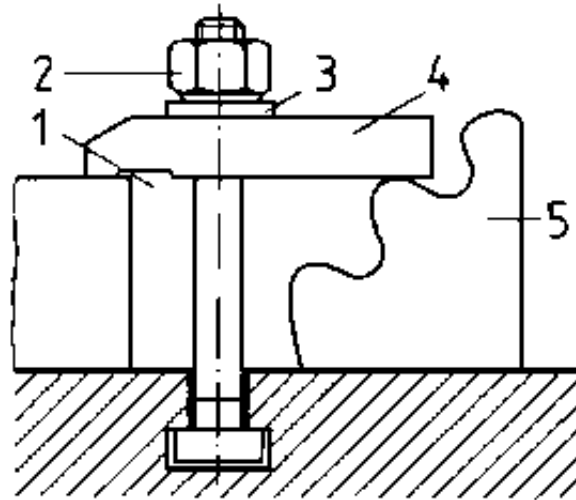

Figure 20 Clamping elements

- 1 clamp bolt**
- 2 nut**
- 3 washer**
- 4 clamping iron**
- 5 step block (work-holding base)**

Fixtures for milling parallel surfaces are used in those cases where a definite positioning and securing of the position of the workpiece is not possible with common clamping means. When a great number of pieces is produced, the employment of multi-piece clamping fixtures is economically substantiated.

Which work-holding fixtures are used for face and parallel milling?

What is especially to be taken care of when thin-walled and unstable workpieces are clamped?

Clamping of workpieces for milling

Depending on the size of the surface to be machined and the kind of the workpiece material, the plain or face milling procedure with super-speed steel or carbide-tipped milling cutters is applied.

Milling tools for face and parallel milling are to be clamped safely and as vibration-free as possible. For milling on the vertical milling machine, milling arbors being as short as possible should be used. The milling cutter (face milling cutter) may also be clamped on the milling spindle directly. When milling on the horizontal miller, milling tools should be set close to the milling spindle for the employment of long milling arbors and a second counterstay is to be used.

Carbide-tipped milling tools are applied for machining work-pieces made of steel or cast iron. Due to the higher cutting values being obtained with these tools, a more rapid (time-saving) execution of the milling process is effected.

The application of super-speed steel milling tools requires a coolant unit to be available and used.

Wear protective gloves or use a rag when clamping milling tools to avoid

cuts to your hands.

Selection of cutting values

The selection of cutting values (speed and rate of feed) is determined by the requirement made on the surface finish (roughness) of the workpiece to be machined.

Cutting values are listed in nomographs or tables or can be calculated.

$$n = \frac{v \cdot 1000}{d \cdot \pi} (\text{min}^{-1})$$

$$v_f = s_z \cdot z \cdot n \text{ (mm/min.)}$$

s_z = feed per each milling cutter edge (mm)

z = number of milling cutter edges

$$\pi = 3.14$$

For workshop exercises, above formula can be simplified to the approximate formula

$$n = \frac{v \cdot 320}{d} .$$

Selection and employment of measuring and testing tools

Selection and employment of measuring and testing tools to check the plane and parallel surfaces milled depend on the following:

- Size of the permissible tolerances of workpiece surfaces, planeness, parallelism and dimensions as well as surface finish (roughness);**
- Size of the surfaces to be checked (small-size or large-size parts);**
- Number of workpieces to be checked (single parts, small-scale, medium or large-scale series).**

The following measuring and testing tools are mainly used:

- Bevelled-steel edge/straight-angle**
- Dial gauge**
- Caliper gauge**
- External micrometers**
- Surface plates**

When using measuring and testing tools, attention is to be paid to the fact that workpieces heated by the machining process are not checked. Due to the physical properties of metals, they expand when heated and that results in off-size conditions when the workpiece cools down. The standardization of reference temperature for testing is 20 C (20 degrees centigrade).

Measuring and testing tools are to be protected against damages. Workpieces should be cleaned and deburred before being measured and tested. After measuring and testing tools have been used, their unprotected metallic surfaces

have to be greased to provide an anti-corrosive effect.

What is necessary to do before any measuring and testing procedure?

How is parallelism of surfaces checked?



[Home](#) > [ar](#).[cn](#).[de](#).[en](#).[es](#).[fr](#).[id](#).[it](#).[ph](#).[po](#).[ru](#).[sw](#)

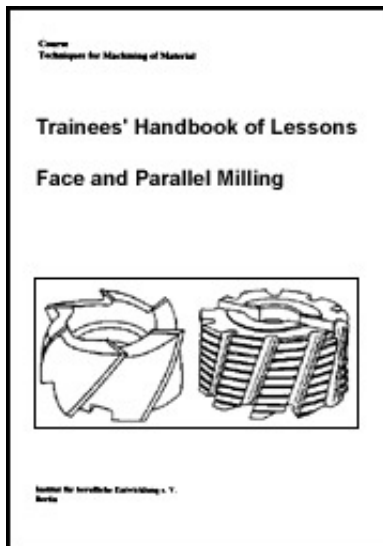

 **Face and Parallel Milling - Course: Techniques for machining of material. Trainees' handbook of lessons (Institut für Berufliche Entwicklung, 21 p.)**

 **(introduction...)**

 **1. Purpose and importance of face and parallel milling**

 **2. Kinds of milling tools to be employed**

 **3. Preparing face and parallel milling**

  **4. Face milling**

 **5. Parallel milling**

4. Face milling

The milling machine (horizontal or vertical miller) is set up according to the

geometrical form of the workpiece, the position and size of the surface to be machined, the number of workpieces, the kind of workpiece material and the kind of milling machine available for plain milling or face milling. Mostly, the more effective milling process - face milling - is applied to milling plane surfaces. In this process higher cutting values are possible due to the employment of carbide-tipped milling tools when compared to plain milling.

Sequence of operations:

- Check the serviceability of the milling machine and lubricate it according to the maintenance schedule.**
- Select speed and rate of feed (nomograph or calculation) and set them accordingly. Turn the machine table to working position .**
- Clamp the workpiece so that the material to be removed always projects above the highest point of the work-holding fixture. Thus, work-holding fixture and milling tool are protected against damage.**
- Then, "scratching" is done, i.e. the milling cutter with running speed is brought close to the workpiece surface so that it scratches at the highest points of the surface not yet machined.**
- Following, the required depth of cut is adjusted and the surface is roughly milled.**
- After the machine table has been retracted to the starting position, the specified size is checked.**

- **In dependence of the machining tolerance still existing, the second milling operation is conducted, i.e. finish-milling of the surface is effected.**
- **After the finished size has been achieved, the workpiece is unclamped, deburred at the cutting edges and checked for planeness, accuracy to size and surface finish.**
- **When all requirements as to accuracy to size, planeness and roughness are fulfilled, all the workpieces are milled, de-burred and checked according to the task set.**
- **After the work order has been successfully terminated, the milling machine, milling tools, clamping and testing tools as well as the workplace are cleaned.**

What is to be noted when chips are flying around?



[Home](#) > [ar](#).[cn](#).[de](#).[en](#).[es](#).[fr](#).[id](#).[it](#).[ph](#).[po](#).[ru](#).[sw](#)

 **Face and Parallel Milling - Course: Techniques for machining of material. Trainees' handbook of lessons (Institut fr Berufliche Entwicklung, 21 p.)**

 **(*introduction...*)**



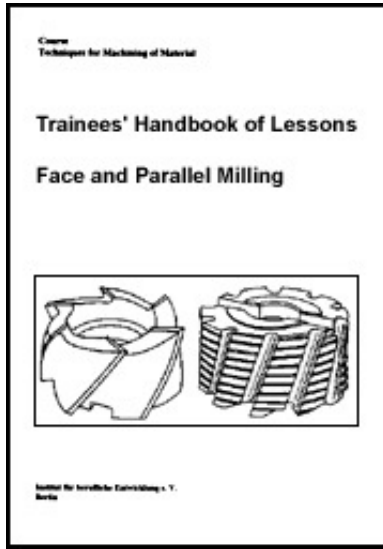

1. Purpose and importance of face and parallel milling
2. ~~2. Types of milling tools to be employed~~
3. Preparing face and parallel milling
4. Face milling
- ➔ 5. Parallel milling

5. Parallel milling

Essentially, the milling machine is set up for parallel milling in the same way as for face milling.

What is to be taken notice of and checked before a milling machine is put into operation?

Sequence of operations:

- The clamping means for positioning and securing the workpiece are fixed and aligned in the same way as for face milling.
- Setting-up of cutting values on the milling machine is followed by the so-

called "scratching", by adjusting the depth of cut and the first milling operation (rough milling). After having finished the first size control, the required finish-size is set and the second milling operation is conducted (finish-milling).

- Now, the milling machine is reset, i.e. set for milling of parallel surfaces according to the task set.

- Parallel surfaces may, for instance, be a second longitudinal or flat side of a prismatic workpiece or they may be surfaces of a kind of section and running in parallel line to the first side (plane surface).

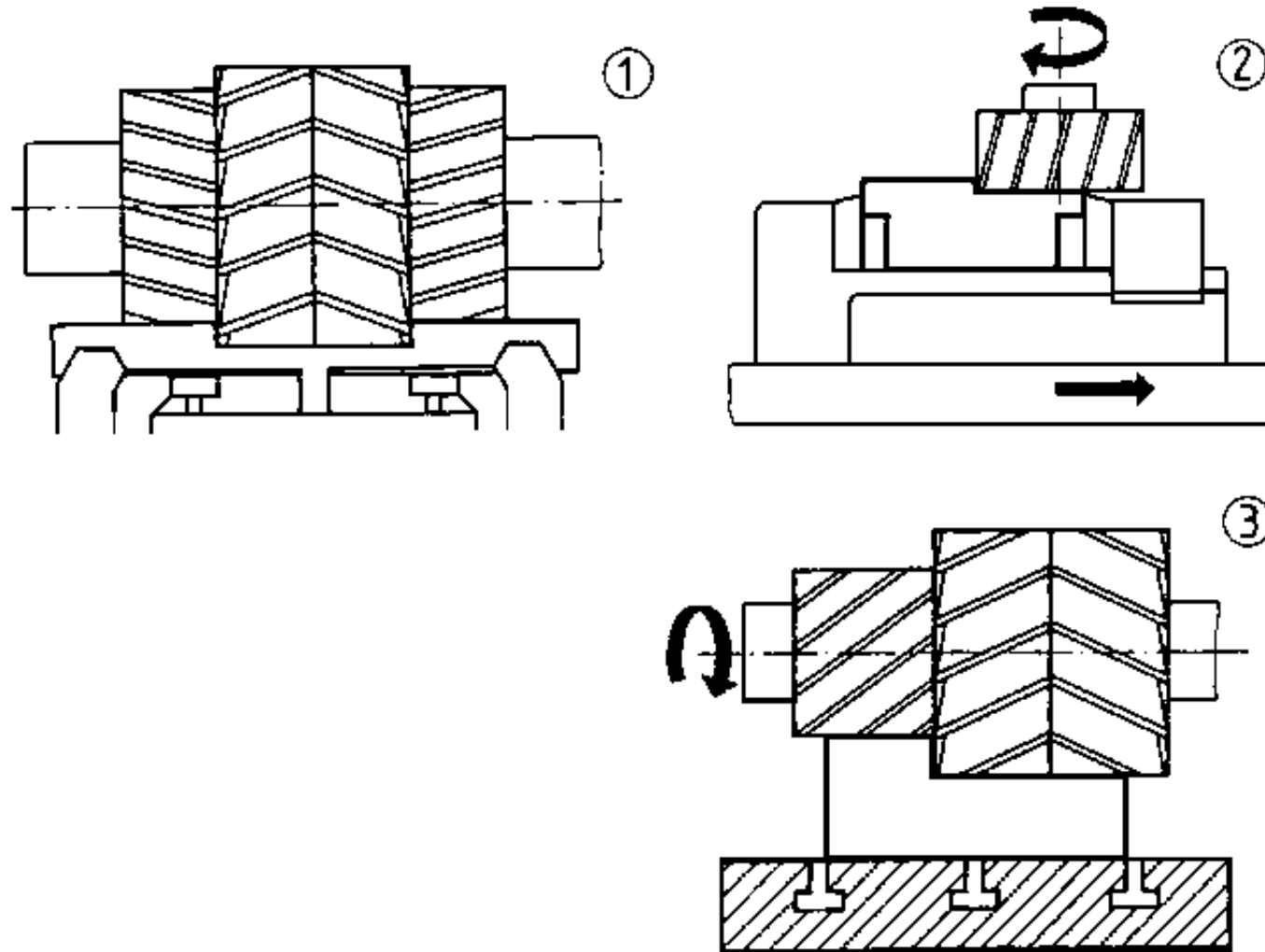

Figure 21 Face and parallel milling

- (1) plane surface (plain milling)**
- (2) parallel surface (face milling)**
- (3) parallel surfaces**

Figure 22 shows the setting-up of the milling machine for parallel milling with the

gang milling cutter.

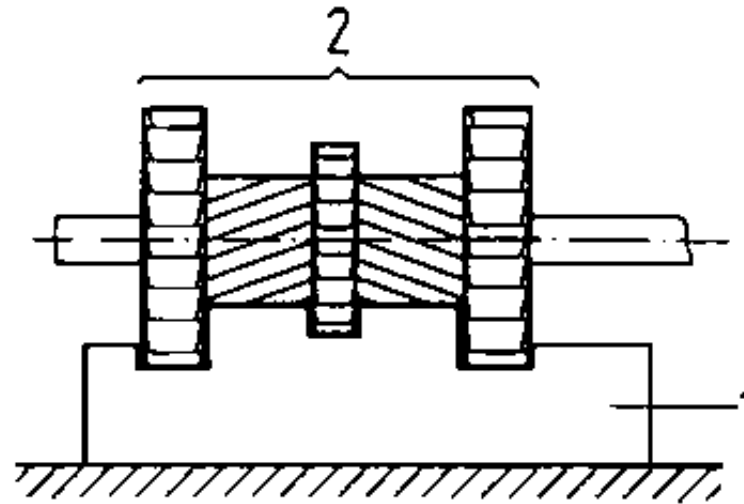

Figure 22 Milling with gang mill cutters

1 workpiece, 2 gang mill cutter consisting of 3 side milling cutters and 2 plain milling cutters

- When the parallel milling of the first workpiece has been terminated, accuracy control and, a possible correction of size adjustment is effected if necessary. Subsequently, the remaining workpieces are machined and quality is permanently controlled.

Paying attention to the entire milling operation, checking accuracy permanently and adhering to the labour safety regulations ensure a trouble-free production run.

- After the successful termination of the work order, the milling machine,

cutting tools, clamping and testing tools as well as the total workplace are cleaned.

Which operational steps are necessary for milling parallel surfaces?

