

➔ **Milling of Grooves, Elongated Slots and Break-throughs - Course: Techniques for machining of material. Trainees' handbook of lessons (Institut für Berufliche Entwicklung, 24 p.)**

📄 **(introduction...)**

- 📄 **1. Purpose and importance of milling grooves, elongated slots and break-throughs**
- 📄 **2. Kinds of milling tools to be used**
- 📄 **3. Preparation of milling grooves, elongated slots and break-throughs**
- 📄 **4. Milling of grooves**
- 📄 **5. Milling of elongated slots**
- 📄 **6. Milling of break-throughs**



📖 **Milling of Grooves, Elongated Slots and Break-throughs - Course: Techniques for machining of material. Trainees' handbook of lessons (Institut für Berufliche Entwicklung, 24 p.)**

➔ 📄 **(introduction...)**

- 📄 **1. Purpose and importance of milling grooves, elongated slots and break-throughs**
- 📄 **2. Kinds of milling tools to be used**
- 📄 **3. Preparation of milling grooves, elongated slots and break-throughs**

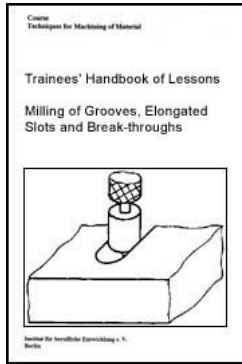

4. Milling of grooves



6. Milling of break-throughs

**Institut für berufliche Entwicklung e. V.
Berlin**

**Original title:
Arbeitsmaterial für den Lernenden
"Fräsen von Nuten, Langschlitten und Durchbrüchen"**

Author: Dieter Frank

First edition © IBE

**Institut für berufliche Entwicklung e.V.
Parkstraße 23
13187 Berlin**





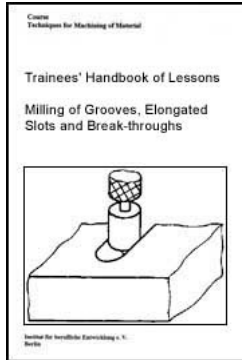

Order No.: 90-35-3305/2





Milling of Grooves, Elongated Slots and Break-throughs - Course: Techniques for machining of material. Trainees' handbook of lessons (Institut für Berufliche Entwicklung, 24 p.)

(introduction...)

-   **1. Purpose and importance of milling grooves, elongated slots and break-throughs**
-  **2. Kinds of milling tools to be used**
-  **3. Preparation of milling grooves, elongated slots and break-throughs**
-  **4. Milling of grooves**
-  **5. Milling of elongated slots**
-  **6. Milling of break-throughs**

1. Purpose and importance of milling grooves, elongated slots and break-throughs

Grooves, elongated slots and break-throughs can be made in different shapes and in different ways by the technique of milling.

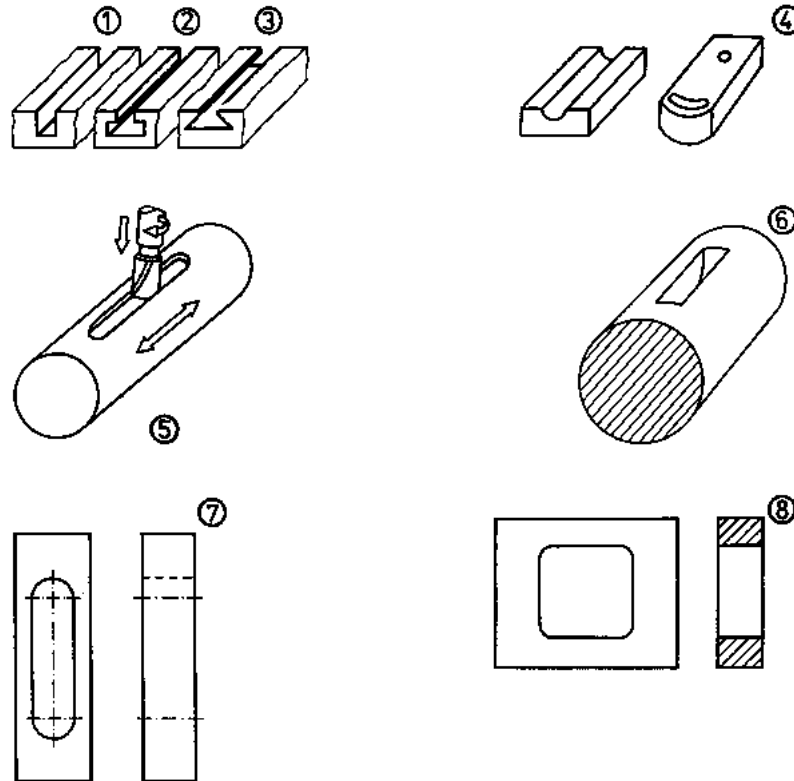

Figure 1 - Examples of grooves, elongated slots and break-throughs

- (1) rectangular groove**
- (2) T-slot**
- (3) dovetail groove**

- (4) radius groove**
- (5) fitting key slot**
- (6) disk key slot**
- (7) elongated slot**
- (8) break-through**

Grooves, elongated slots and break-throughs are produced or made for the purpose of

- receiving fitting keys and feathers to ensure or transmit torques (power transmission) when mating an inner member (shaft) with an outer member (bore hole), e.g. when connecting a shaft with a toothed gear;

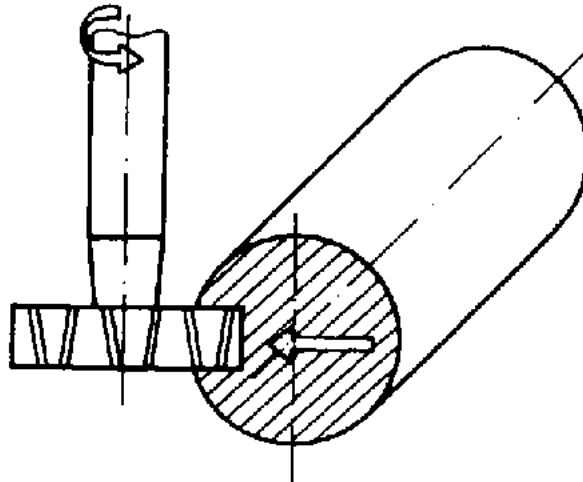

Figure 2 - Groove in shafts Rectangular groove in plane surfaces

- setting various spacings, e.g. in the case of change-gear quadrants; to tension

belt drives and to ensure different setting ranges for assembling constructional elements of different order or magnitude;

- receiving clamping elements (e.g. clamping bolts in T-slots) or receiving tongues for determining the position of workpiece clamping means and workpiece;

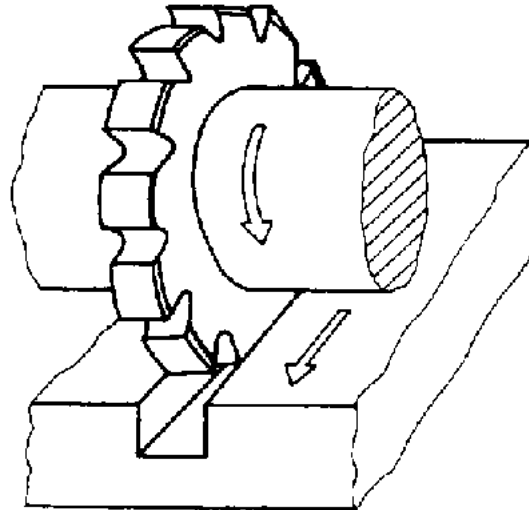

Figure 3 - Rectangular groove

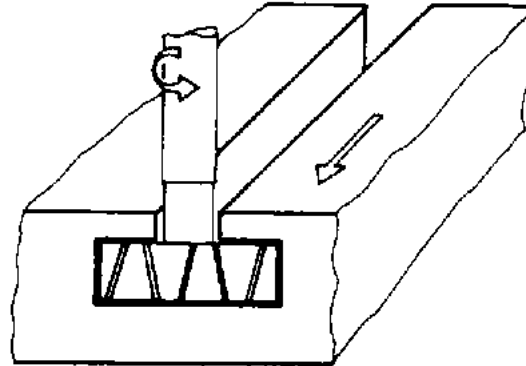

Figure 4 - T-slot

- providing the necessary space for receiving or passing through of other workpieces or assemblies or making openings for the insertion of control elements (switches, levers, handwheels etc.).

Machining or producing of grooves, elongated slots and break-

- throughs is possible on horizontal and vertical milling machines and on groove and slot milling machines.

What kinds of grooves exist on a milling machine?

On what kinds of milling machines is it possible to produce grooves, elongated slots and break-throughs?

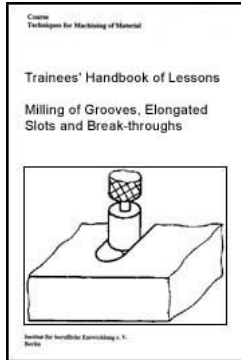

Milling of Grooves, Elongated Slots and Break-throughs - Course: Techniques for machining of material. Trainees' handbook of lessons (Institut für Berufliche Entwicklung, 24 p.)

(introduction...)

1. Purpose and importance of milling grooves, elongated slots and break-throughs

➔ 2. Kinds of milling tools to be used

3. Preparation of milling grooves, elongated slots and break-throughs

4. Milling of grooves

5. Milling of elongated slots

6. Milling of break-throughs

2. Kinds of milling tools to be used

For milling grooves, elongated slots and break-throughs the following milling tools are applied:

- **slotting mill, shank cutter, T-slot shank cutter**
- **twist drill fluting cutter (two-flute or three-flute cutter)**
- **cylindrical cutter, grooving cutter, interlocked cylindrical cutters**
- **angular cutter with parallel shank**
- **radius cutter for milling radius grooves.**

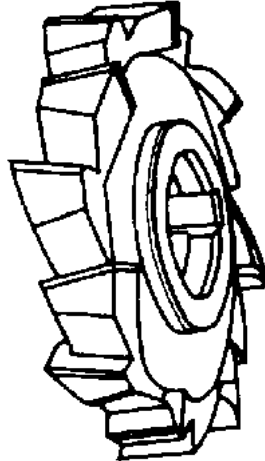

Figure 5 - Cylindrical cutter (with staggered teeth)

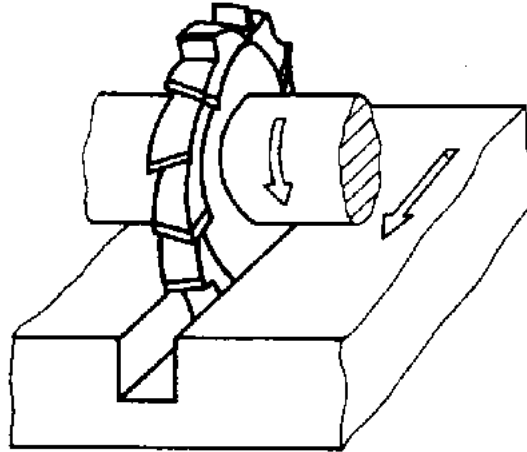

Figure 6 - Grooving cutter (with straight teeth, relieved by turning)

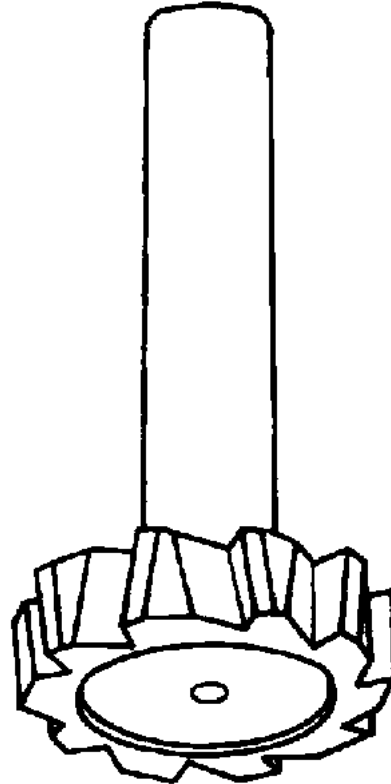

Figure 7 - T-slot cutter



Figure 8 - Twist drill fluting cutter (two--flute cutter)

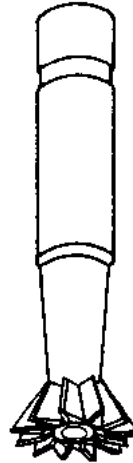

Figure 9 - Angular cutter with parallel shank



Figure 10 - Shank-type slotting mill

The milling tools mentioned shall be used with the corresponding tool clamping means and fixtures on the column-and-knee-type milling machine (horizontal or vertical milling machine) or on the groove or slot milling machine.

The milling tools used for milling grooves, elongated slots and break-throughs are mainly tools made of super high-speed steel. When tools of this material are applied it is absolutely necessary to use coolant during milling. The use of coolant also depends on the material of the workpiece. Cast materials, for example, do not require coolant.

Before using milling tools it is necessary, especially for milling grooves and elongated slots, to check

- the cutter width of cylindrical cutters or
- the cutter diameter of twist drill fluting cutters, slotting mills and shank cutters.

For checking the width of a cylindrical cutter a vernier caliper is suited and for the twist drill fluting cutter also a vernier caliper (if the cutter has two lips) or a limit gauge/bore gauge for cutters with an uneven number of lips (e.g. three-flute cutter) are suitable.

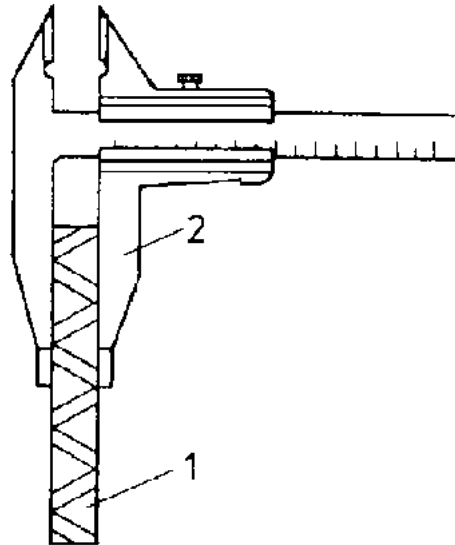

Figure 11 - Measuring of cutter width

1 - cylindrical cutter (with staggered teeth)

2 vernier caliper

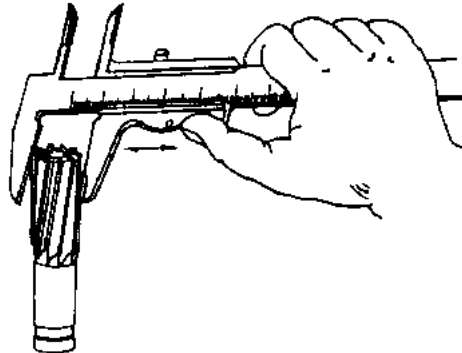

Figure 12 - Measuring of cutter diameter with vernier caliper

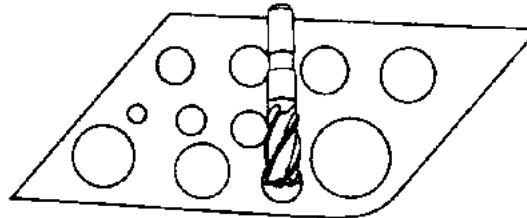
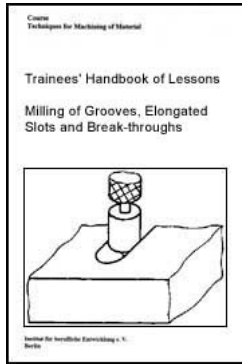

Figure 13 - Checking of cutter diameter with plug gauge (in case of cutters with an uneven number of cutting edges, e.g. with three or five cutting edges)



[Home](#) > [ar.cn.de.en.es.fr.id.it.ph.po.ru.sw](#)

 Milling of Grooves, Elongated Slots and Break-throughs - Course:



Techniques for machining of material. Trainees' handbook of lessons (Institut für Berufliche Entwicklung, 24 p.)

 **(introduction...)**

 **1. Purpose and importance of milling grooves, elongated slots and break-throughs**

 **2. Kinds of milling tools to be used**

 **3. Preparation of milling grooves, elongated slots and break-throughs**

 **4. Milling of grooves**

 **5. Milling of elongated slots**

 **6. Milling of break-throughs**

3. Preparation of milling grooves, elongated slots and break-throughs

Preparation of these techniques includes the following operations:

- Prepare in your mind the sequence of operations like

- choice of milling machine to be used**
- choice of milling and clamping tools to be used**
- choice of measuring and testing means to be used**
- technological flow of milling operations for meeting the quality requirements.**

- Lay out the necessary tools, measuring and testing means and auxiliary equipment while observing the basic rules for properly putting them down and securing them in position.

- **Check the functionality and operational safety of the tools and auxiliary equipment to be applied before using them. Sort out worn tools.**
- **Check also the milling machine to be used for functionality and operational safety. Check the oil level and lubricate the milling machine according to the lubrication schedule.**

Clamping the workpiece for milling

There is a number of possibilities for clamping the workpiece to mill grooves, elongated slots and break-throughs. Their choice and application depend on the following factors:

- **the geometrical shape and dimensions of the workpiece. The workpiece may have a prismatic or rotationally symmetrical shape. As far as the dimensions are concerned, length, width or diameter and height are to be considered.**
- **the position of the groove, elongated slot or break-through to be milled on the workpiece;**
- **the accuracy requirements (dimensional and positional deviations as well as shape errors);**
- **the number of workpieces to be machined (single parts, small, medium or large series) and**
- **the workpiece clamping and auxiliary equipment available in the production department.**

The most frequently used workpiece clamping equipment for milling grooves, elongated slots and break-throughs are the following:

- **machine vice of standard design**
- **machine vice with prismatic jaws**
- **shaft vice**
- **chuck (three-jaw and four-jaw chuck)**
- **clamping of the workpieces directly on the machine table or on a circular table**
- **work-holding fixtures**

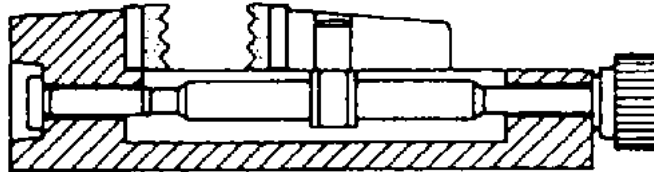

Figure 14 - Machine vice with prismatic jaws

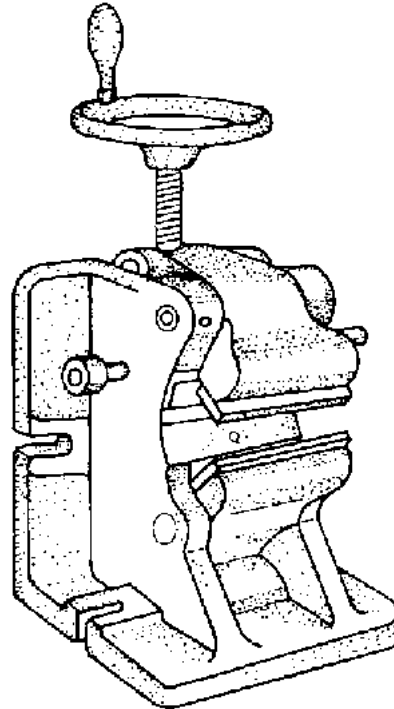

Figure 15 - Shaft vice

The workpieces are clamped mainly as individual parts. The application of auxiliary clamping equipment, e.g. stops, serves for determining the position in order to constantly reach a specified spacing from a given reference surface.

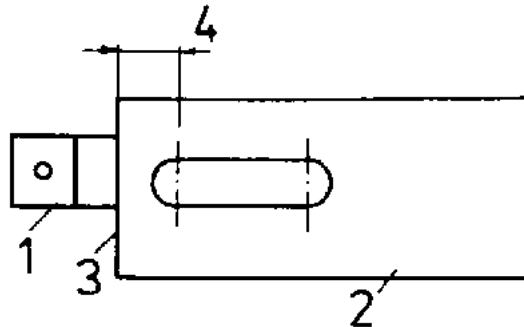

Figure 16 - Workpiece stop

- 1 - stop block
- 2 - workpiece
- 3 - reference surface
- 4 - spacing size

When clamping workpieces, take care to ensure that the bearing surfaces (locating and supporting surfaces) are free from burrs and clean. Impurities and burrs result in positional deviations during clamping and leave damaged spots (marks) on the workpiece surface.

When handling sharp-edged workpieces and tools (milling tools), wear protective gloves to prevent cutting your hands. Deburr the workpieces only with proper files (firmly secured and undamaged file handle).

- **When clamping the workpieces in the machine vice, take care to ensure that the work locating and supporting surfaces (parallels and vice jaws) are clean and undamaged.**
- **Rotationally symmetrical workpieces are clamped in the prismatic vice or, when**

prismatic jaws are used, in the machine vice. For this purpose it is necessary that the prismatic jaws are without any impurities in their seats or guideways. Otherwise there will be positional deviations of the workpiece.

- When clamping the workpieces directly on the machine table, pay attention to the following:

- **Determine the position by using tongues, stop bars, stops and other auxiliaries according to the accuracy requirements.**
- **Fix clamping means (clamps, clamping bolts) at those points of the workpiece, where they do not hinder the milling operation (free space for milling tool and tool clamping means).**
- **Use appropriate stops to uniformly obtain the required spacing dimensions (dimensions from a reference surface) so that the determination of the position of the workpieces is clearly repeatable.**
- **When using workpiece clamping means be careful not to make any changes to the supporting or locating surfaces. Before mounting the means on the machine table or on the circular table, for example, clean the base surface of the fixture and the table surface.**

Clamping of tools for milling

The tool clamping means for milling grooves, elongated slots and break-throughs include the following:

- **cutter arbors (long and short)**
- **cutter chuck with collets (for cutters with parallel shank)**

- adapter sleeves (for receiving shank cutters with taper shanks)

Work with extreme cleanliness when clamping the milling tools on the cutter arbor in the cutter chuck or when using adapter sleeves. This ensures thrust accuracy and concentricity of the milling tools.

For setting the tool clamping means use exclusively the corresponding tools like the pin spanner for the sleeve nut or the reducing sleeve with the corresponding taper (internal and external taper).

Regardless of the kind of workpiece clamping and tool clamping means to be used always pay attention to the labour safety requirements.

To prevent accidents and injuries, use the cutter safety devices according to their purpose. Use proper files for deburring the workpieces before clamping or before measuring and testing. To prevent hand injuries, move sharp-edged work-pieces and milling tools with protective gloves or a rag.

Choice and application of measuring and testing means

By measuring and testing a certain accuracy is to be reached in the milling process and dimensional and positional deviations are to be avoided.

The following measuring and testing means are used

- vernier caliper**
- vernier depth gauge**
- slip gauges**
- back squares/dial gauge**
- limit gauges (plug limit gauges)**

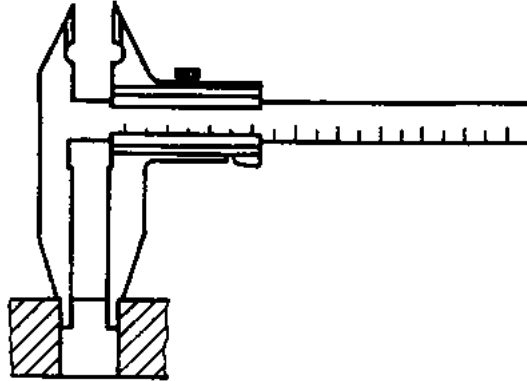

Figure 17 - Vernier caliper

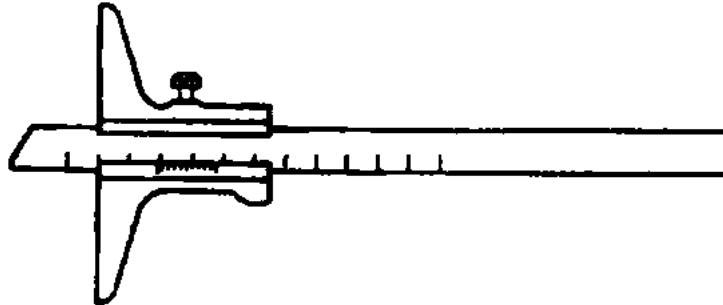

Figure 18 - Vernier depth gauge

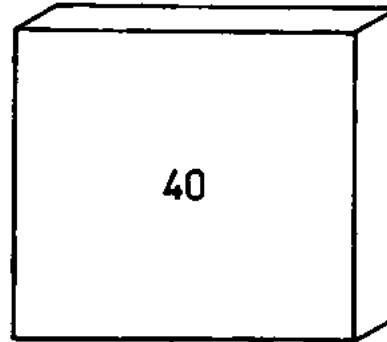

Figure 19 - Slip gauge

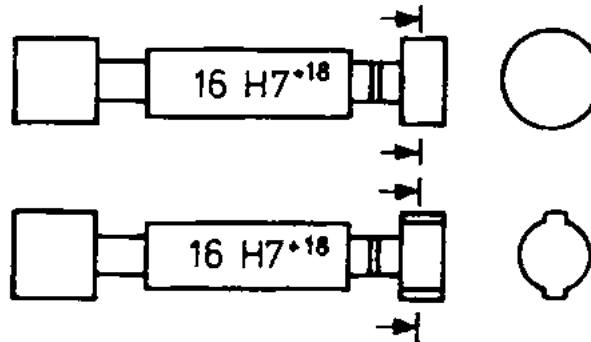

Figure 20 - Limit gauge

Deburr and clean the workpieces before measuring and testing them. Use only serviceable and undamaged measuring and testing means. Send measuring and testing means for a regular check - depending on how frequently they are used (6 to 12 months' cycle) to the corresponding department of the factory. Do not use damaged measuring and testing

means any more and send them to the repair shop immediately.

The life of measuring and testing means depends on how carefully they are handled and laid down at the workplace.

How can inaccuracies by avoided when clamping the workpieces?

What possibilities of clamping the milling tools for milling grooves exist?

What must be done when a measuring and testing means gets damaged during work?



Home > [ar](#).[cn](#).[de](#).[en](#).[es](#).[fr](#).[id](#).[it](#).[ph](#).[po](#).[ru](#).[sw](#)

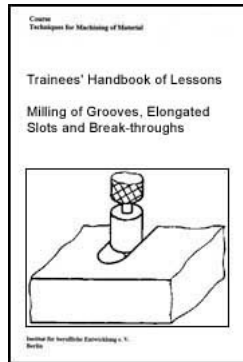

Milling of Grooves, Elongated Slots and Break-throughs - Course: Techniques for machining of material. Trainees' handbook of lessons (Institut fr Berufliche Entwicklung, 24 p.)

(introduction...)

1. Purpose and importance of milling grooves, elongated slots and break-throughs

2. Kinds of milling tools to be used

3. Preparation of milling grooves, elongated slots and break-throughs

➔ 4. Milling of grooves

5. Milling of elongated slots

 **6. Milling of break-throughs****4. Milling of grooves**

Grooves are milled recesses in workpieces which may have various geometrical shapes (prismatic, rotationally symmetrical) and sizes. We distinguish between the following kinds of grooves:

- rectangular groove
- T-slot
- dovetail groove
- fitting key groove
- radius groove
- tooth-shaped grooves (gullet and chip grooves).

Grooves are made with different accuracy specifications according to their application. Grooves for receiving objects or transmitting torques (fitting key slot/fitting key, disk key slot/disk key or T-slot/tongues) are made with small tolerances (permissible deviations from the nominal size) as fitting size (e.g. 20^{H7}). The tolerances for fitting sizes shall be taken from corresponding standards or tables.

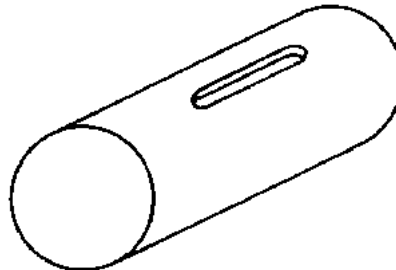

Figure 21 - Fitting key slot

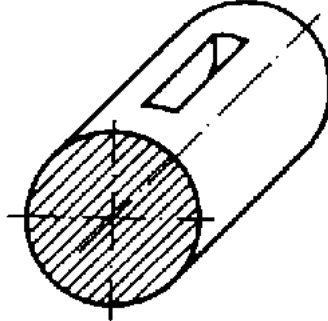

Figure 22 - Disk key slot

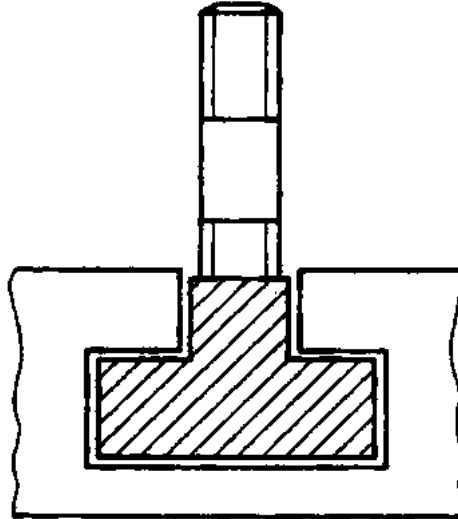

Figure 23 - Tongues - clamping bolt

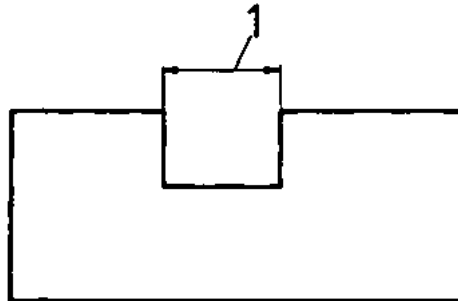

Figure 24 - Fitting size of a groove

Workpiece with groove: 1 fitting size 20^{H7} (upper deviation = 0.021 mm; lower deviation = ± 0 ; tolerance = 0.021 mm)

For milling grooves the following milling machines are suited:

- For rectangular grooves, radius grooves and tooth-shaped grooves mainly horizontal milling machines are used.
- For T-slots and dovetail grooves horizontal milling machines are used for the first operation which is milling of the rectangular groove. For the second operation - milling of the undercut of the T-slot or milling of the dovetail - mainly vertical milling machines are used.

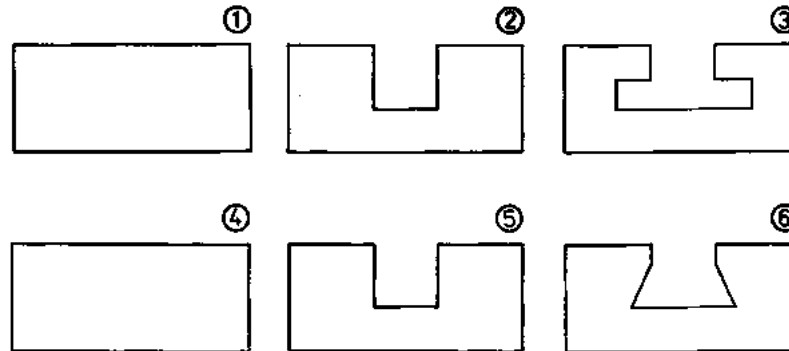

Figure 25 - T-slot and dovetail groove

- (1) workpiece**
- (2) workpiece with rectangular groove**
- (3) workpiece with T-slot**
- (4) workpiece**

(5) workpiece with rectangular groove

(6) workpiece with dovetail groove

- For fitting key slots either vertical milling machines, in few cases also horizontal milling machines or groove and slot milling machines are applied when large numbers of pieces (medium and large series) are involved.

Milling of grooves is carried out in accordance with the following working steps:

- Check the functionality and operational safety of the milling machine to be used (check oil level and lubricate).

- Lay out the necessary workpiece clamping and tool clamping means as well as measuring and testing means.

- Align and set up the workpiece clamping means and fix or chuck the milling tool.

- Mount the coolant system and the cutter safety guard.

- Bring the milling machine table into the working position in relation to the milling tool (X-Y-Z direction) and set the cutting values.

If the workpieces are rotationally symmetrical, positioning, i.e. setting of the milling tool to the centre of the work-piece, requires special auxiliary equipment. For setting the cutter to the workpiece centre use a back square and corresponding slip gauges. The spacing between outer edge of the workpiece and outer edge of the milling tool, when measured from left and from right, must always be the same.

- Scratch, feed the cutting depth and rough-mill the groove.

- Check the dimensions, feed the necessary amount and finish milling the groove.

- Unclamp or remove the workpiece, deburr the cut edges and clean the workpiece. Check the dimensions and examine the surface.

Milling of small grooves (width) of large depth requires several working steps. When milling is performed in one working step there is the danger of overloading the milling tool which may result in breakage of the cutter, the dimensional check is made with the vernier caliper, with slip gauges or with a plug limit gauge according to the required dimensional accuracy.

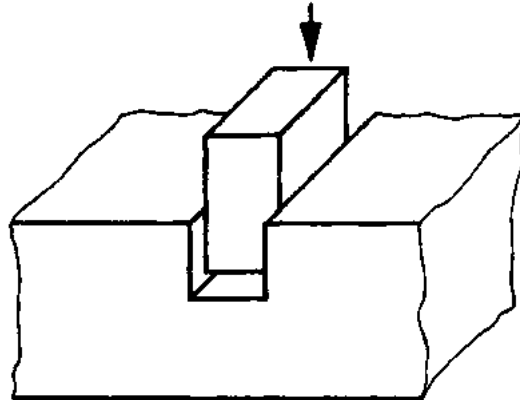

Figure 26 - Checking with slip gauge

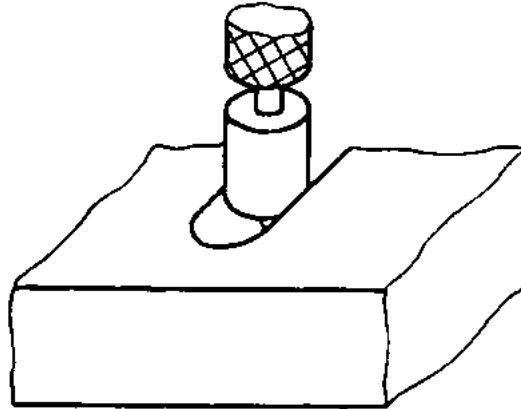

Figure 27 - Checking with limit gauge

If necessary, make corrections concerning the localization of the workpiece, the spacing dimensions in relation to the reference surfaces and the groove width. Put the dials of manual adjustment (knee and saddle) into the zero position and set up the necessary table dogs.

When changing the workpiece, make sure that the demands stipulated for clamping (freedom from burrs, cleanliness on the supporting and locating surfaces) are met. Regular checking of the workpieces as to meeting the quality requirements helps to prevent the production of scrap components (unservicable work-pieces).

After having finished the milling of grooves, clean the milling machine, all tools used and the whole workplace.

What is a groove?

What are the basic kinds of grooves?

What has to be considered when milling T-slots?



[Home](#) > [ar](#).[cn](#).[de](#).[en](#).[es](#).[fr](#).[id](#).[it](#).[ph](#).[po](#).[ru](#).[sw](#)

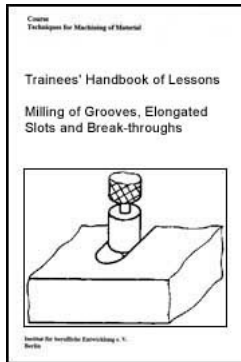

 **Milling of Grooves, Elongated Slots and Break-throughs - Course: Techniques for machining of material. Trainees' handbook of lessons (Institut fr Berufliche Entwicklung, 24 p.)**

 **(introduction...)**

 **1. Purpose and importance of milling grooves, elongated slots and break-throughs**

 **2. Kinds of milling tools to be used**

 **3. Preparation of milling grooves, elongated slots and break-throughs**

 **4. Milling of grooves**

 **➔ 5. Milling of elongated slots**

 **6. Milling of break-throughs**

5. Milling of elongated slots

Elongated slots are recesses in workpieces which are made with a limited length in the form of the "elongation" of a workpiece bore hole by milling into a given direction.

Elongated slots can have a unilaterally or bilaterally limited length. Unlike the groove they completely penetrate the workpiece in full height, width or diameter.

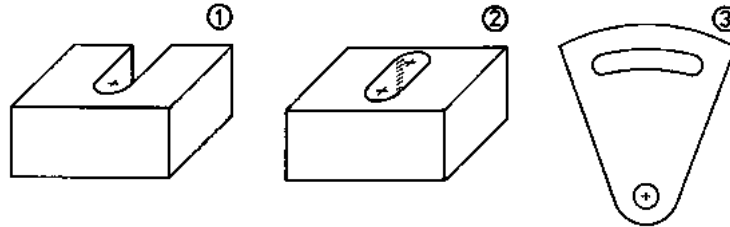

Figure 28 - Elongated slot

- (1) length unilaterally limited**
- (2) length bilaterally limited**
- (3) semicircular elongated slot**

Elongated slots are produced mainly by plunge milling (plunge face milling). To do this, twist drill fluting cutters shall be used as milling tool.

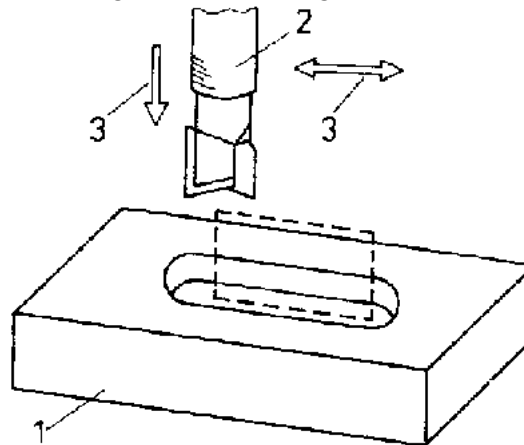

Figure 29 - Plunge face milling

- 1 - workpiece**
- 2 - twist drill fluting cutter**
- 3 - plunging and cutting direction**

When shank cutters are used, preliminary drilling with a drilling tool is necessary, as the face cutting edges of the shank cutter do not allow "plunging". The face cutting edges do not extend to the central axis of the cutter. Elongated slots are made with different accuracy specifications according to the application. When the workpieces are made of cast iron, the shape of the elongated slot has usually been cored with the necessary machining allowance.

Elongated slots can run in parallel to the prismatic or rotationally symmetrical outer surfaces of the workpiece. In few cases they are curved (semicircular), e.g. in the case of a change--gear quadrant.

Elongated slots frequently occur in the clamping means for milling (e.g. clamps, stop bars, etc.). For milling elongated slots the following milling machines are suitable:

- **Vertical milling machines are mainly used. Depending on the geometrical shape and size of the workpiece as well as the position of the elongated slot in the workpiece, horizontal milling machines are also suited.**
- **When large numbers of pieces are machined (medium and large series), groove and slot milling machines are applied.**
- **For making elongated slots of curved shape the circular dividing table on the vertical milling machine is used.**

Milling of elongated slots is carried out in the following sequence of operations:

- **Check the functionality and operational safety of the milling machine to be used (check oil level and lubricate).**
- **Lay out the necessary workpiece clamping and tool clamping means as well as measuring and testing means.**
- **Fix, align and set the workpiece clamping means, clamp the work-piece, fix or chuck the milling tool.**
- **Mount the coolant system and the cutter safety guard.**
- **Bring the milling machine table into the working position in relation to the milling tool (X-Y-Z direction) and set the cutting values.**
- **Scratch and set the length of the elongated slot (stops at machine table), rough-mill the elongated slot.**

- Carry out visual examination and dimensional check (length and width) and corrections, if necessary, and finish milling the elongated slot.

- Unclamp or remove the workpiece, deburr the cut edges and clean the workpiece. Make a visual inspection, dimensional check and surface examination according to the specifications.

What is the difference between a groove and an elongated slot?

What functions do elongated slots have?



[Home](#) > [ar](#) [cn](#) [de](#) [en](#) [es](#) [fr](#) [id](#) [it](#) [ph](#) [po](#) [ru](#) [sw](#)

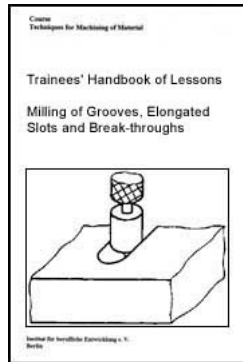

 **Milling of Grooves, Elongated Slots and Break-throughs - Course: Techniques for machining of material. Trainees' handbook of lessons (Institut für Berufliche Entwicklung, 24 p.)**



(introduction...)



1. Purpose and importance of milling grooves, elongated slots and break-throughs



2. Kinds of milling tools to be used



3. Preparation of milling grooves, elongated slots and break-throughs



4. Milling of grooves



5. Milling of elongated slots



6. Milling of break-throughs

6. Milling of break-throughs

Break-throughs are through-milled openings in workpieces which may be of different geometrical shape and size. They may have a square or rectangular basic shape with smaller or larger radii at the "corners". Break-throughs are generally milled with relatively rough accuracy specifications, i.e. according to the corresponding application.

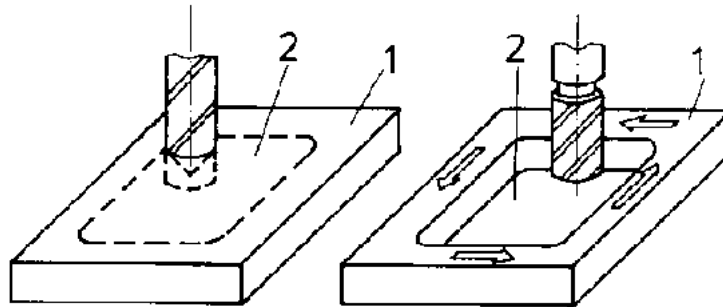

Figure 30 - Break-through

- 1 - workpiece**
- 2 - break-through**

For milling break-throughs it is necessary to predrill at a given point (end point) so that the cutting infeed movement can easily be carried out with a shank cutter.

If possible, for milling break-throughs the frame milling fixtures, usually used with column-and-knee type milling machines, are applied.

For a uniform machining surface the feed direction must be changed without stopping the

feed.

For milling break-throughs the following milling machines are suited:

- vertical milling machines with frame milling fixture frame milling: change of the feed direction from

- **X into Y-direction takes place without stopping the feed.**
- **X-direction corresponds to longitudinal feed.**
- **Y-direction corresponds to cross feed.**

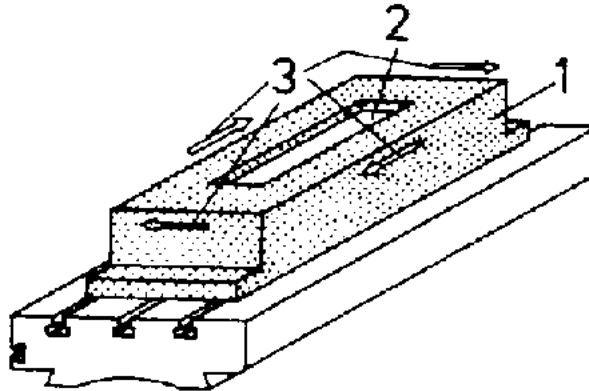

Figure 31 - Frame milling

- 1 - workpiece,**
- 2 - break-through,**
- 3 - directions of motion with frame milling**

- horizontal milling machines with frame milling fixture:

- **change of the feed direction from X into Z-direction**
- **X-direction corresponds to longitudinal feed.**
- **Z-direction corresponds to vertical feed.**

The frame milling programme is set on the selector switch panel or the milling machine.

- Double-column piano-milling machines are used for workpieces which due to their size (dimensions) are not suited for being clamped on a column-and-knee type milling machine.

Setting up for and milling of break-throughs is carried out in the following sequence of operations:

- Check the functionality and operational safety of the milling machine to be used.

- Lay out the necessary workpiece clamping and tool clamping means as well as measuring and testing means.

- Fix, align and set the workpiece clamping means (mainly machine vice or direct clamping on the table), clamp the workpiece, fix or chuck the milling tool.

- Mount the coolant system and the cutter safety guard.

- Position the milling machine table and the frame milling fixture, set the cutting values.

- Scratch and set the length and width of the break-through (stops at machine table and saddle or at machine table and knee), rough-mill the break-through with small cutting depth (0.5 - 1.0 mm).

- Carry out visual examination and dimensional check and, if necessary,

corrections. Finish milling the break-through. The cutting infeed is made at the predrilled point when shank cutters are used.

- Unclamp or remove the workpiece, deburr the cut edges and clean the workpiece. Make a visual inspection, dimensional check and surface examination according to the specifications. Profile gauges or the counterpart are recommended for dimensional check.

- Change the workpiece in accordance with the requirements stipulated for proper clamping and labour safety regulations.

- After having finished milling of break-throughs, clean the milling machine, all tools and auxiliary equipment used and the whole workplace.

What advantage does frame milling offer?

