

➔ **Milling of Offset Faces - Course: Techniques for machining of material. Trainees' handbook of lessons (Institut für Berufliche Entwicklung, 14 p.)**

(introduction...)

1. Purpose and importance of milling offset faces
2. Types of milling tools used
3. Preparation for milling offset faces
4. Milling offset faces



[Home](#) > [ar.cn.de.en.es.fr.id.it.ph.po.ru.sw](#)

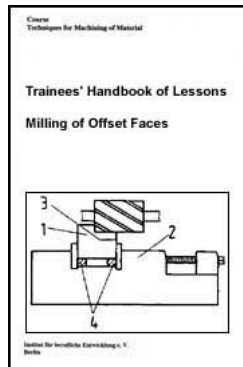

➔ **Milling of Offset Faces - Course: Techniques for machining of material. Trainees' handbook of lessons (Institut für Berufliche Entwicklung, 14 p.)**

➔ **(introduction...)**

1. Purpose and importance of milling offset faces
2. Types of milling tools used
3. Preparation for milling offset faces
4. Milling offset faces

Institut für berufliche Entwicklung e. V.

Berlin

**Original title:
Arbeitsmaterial fr den Lernenden
"Frnsen von abgesetzten Flichen"**

Author: Dieter Frank

First edition © IBE

**Institut fr berufliche Entwicklung e.V.
Parkstrae 23
13187 Berlin**

Order No.: 90-35-3304/2



[Home](#) > [ar](#).[cn](#).[de](#).[en](#).[es](#).[fr](#).[id](#).[it](#).[ph](#).[po](#).[ru](#).[sw](#)

 **Milling of Offset Faces - Course: Techniques for machining of material. Trainees' handbook of lessons (Institut fr Berufliche Entwicklung, 14 p.)**

 **(introduction...)**

  **1. Purpose and importance of milling offset faces**

 **2. Types of milling tools used**

 **3. Preparation for milling offset faces**

 **4. Milling offset faces**

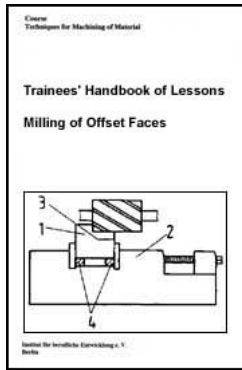

1. Purpose and importance of milling offset faces

The offset faces of workpieces are those faces with ledges, graduations or disengagements (mostly in rectangular shape) which are milled on the longitudinal or end faces.

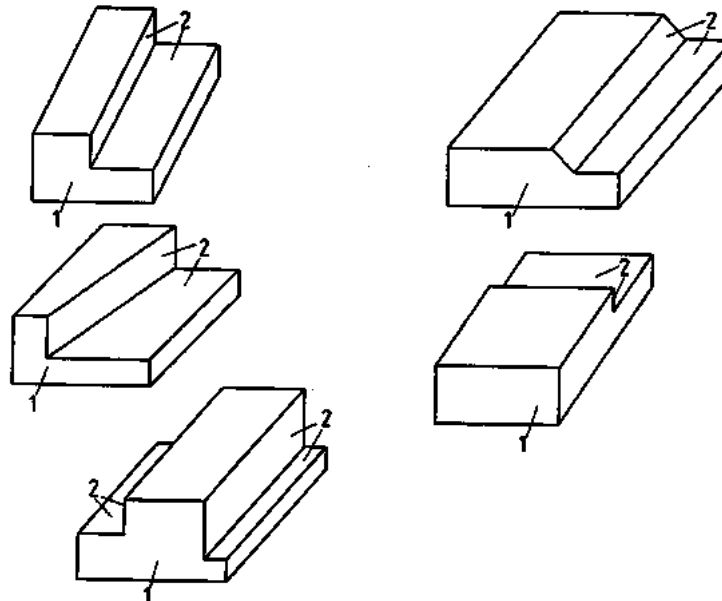

Figure 1 - Depiction of workpiece offset face

- 1 - workpiece**
- 2 - offset face**

Processing or turning out offset faces by milling takes place for:

- yielding the required geometrical shape necessary for the assembly of further elements**
- yielding the necessary geometrical shape needed for a special function of the**

element in the final product

- yielding the necessitated free faces for accomodating operating elements (levers, handles, hand wheels, etc.) or components (screws, nuts, safety elements, etc.).

The processing resp. working of offset faces can ensue using horizontal and vertical milling machines and adopting the plain or end face milling process.

Milling is undertaken by employing milling tools, namely a cylindrical cutter, end face mill, side and face milling cutter and end mill cutter.

A combination of end face mills and side and face milling cutters is possible for milling offset faces. The utilisation of hard metal-tipped milling tools can also ensue depending on the nature of the workpiece material to be processed. Offset faces can be milled:

- in single part or multi-piece chucking
- simultaneously with one or several milling tools (gang gutter)
- by the simultaneous utilisation of two or more work spindles on the portal or two spindle milling machines.

What are offset faces of workpieces?

Why are offset faces turned out? Give examples.

What milling tools are needed for offset faces?



[Home](#) > [ar.cn.de.en.es.fr.id.it.ph.po.ru.sw](#)

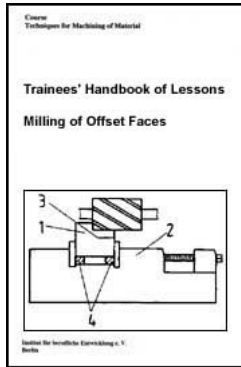

Milling of Offset Faces - Course: Techniques for machining of material. Trainees' handbook of lessons (Institut für Berufliche Entwicklung, 14 p.)

 **(introduction...)**

 **1. Purpose and importance of milling offset faces**

  **2. Types of milling tools used**

 **3. Preparation for milling offset faces**

 **4. Milling offset faces**

2. Types of milling tools used

As both hobbing and end face milling are used for yielding offset faces, the commensurate milling tools are used, namely:

- cylindrical or end face mills
- end mill cutter
- side and face milling cutter alone or combined as gang cutter
- milling heads

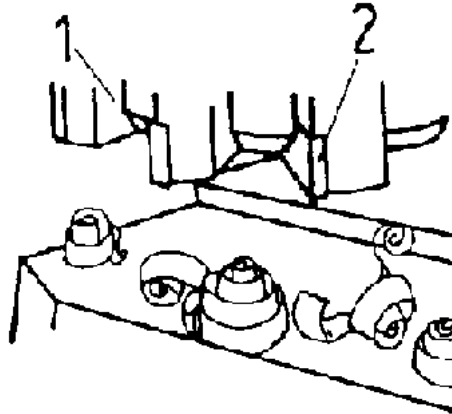

Figure 2 - Milling head

1 - turnover plate milling head

2 - turnover plate (90°)

The required milling tools are used in conjunction with the commensurate workpiece clamping means on horizontal or vertical milling machines.

How can the required distance between the mills of a gang cutter be ensured?

What is the function of the coolant when milling?

Indicate for which milling tool no coolant is required?



[Home](#) > [ar.cn.de.en.es.fr.id.it.ph.po.ru.sw](#)

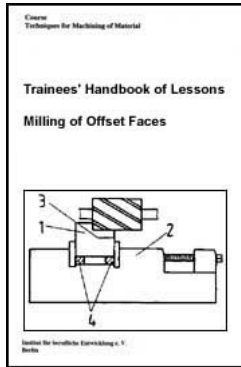

Milling of Offset Faces - Course: Techniques for machining of material. Trainees' handbook of lessons (Institut für Berufliche Entwicklung, 14 p.)

 **(introduction...)**

 **1. Purpose and importance of milling offset faces**

 **2. Types of milling tools used**

 **➔ 3. Preparation for milling offset faces**

 **4. Milling offset faces**

3. Preparation for milling offset faces

The following sequence of operations is necessary in order to prepare the milling of offset faces:

- **conceptual planning of the sequence of operations for milling offset faces**
- **selecting the milling machine to be used**
- **choosing the milling and clamping tools, equally the measuring and testing means**
- **making available the necessary tools and auxiliaries heeding the essential aspects of orderly arrangement**

- **providing the necessary means for adhering to labour safety requirements (gloves, protective goggles, chip catch, hand brush and rags)**
- **determine or calculate the cutting values (rotational speed of the milling spindle, rate of feed, number of runs for each workpiece, rough and final milling)**
- **ensure proper functionality and operating safety of the milling machine, tools and auxiliaries to be used prior to commencing work. Worn tools should be discarded and replaced. Oil level control and milling machine lubrication should be undertaken in accordance with the applicable lubrication instructions.**

Clamping workpieces for milling offset faces

Various clamping possibilities exist for milling offset faces of workpieces. The selection of the appropriate clamping means depends on:

- **the geometrical shape and size (length, width and height) of the workpiece**
- **the position of the workpiece offset faces to be turned out**
- **the accuracy requirements in respect of the offset faces (dimensions, shape and positional deviations)**
- **the number of workpieces to be processed (single units: small, medium or large batch series)**
- **the type of milling machines available (horizontal or vertical milling machine, portal or two spindle milling machine)**
- **the available workpiece clamping means and auxiliaries (vice, clamping square, knee, clamping elements)**

The most frequently employed workpiece clamping means for milling offset faces are:

- clamping in a vice
- clamping directly to the machine table and
- clamping in devices

Workpieces are generally clamped as single items. The adoption of multi-piece chucking depends on:

- the geometrical shape and size of the workpieces to be clamped
- the accuracy requirements in respect of the offset faces
- the number of workpieces to be processed and
- the existing clamping possibilities.

When clamping workpieces, ensure that beforehand the burr is removed and the clamping faces (bearing and supporting surfaces) are cleaned. The clamping tool must be in proper functional order. Metal chips on the workpiece faces or burrs on the already processed faces lead to

- top surface impairment (dents or imprints) and
- workpiece measurement and positional deviations. There is also the danger of injury!

In order to attain the accuracy parameters as set out in the work assignment one must pay considerable attention to positional determination and stability (workpiece supporting and bearing surfaces and clamping force). In the case of accuracy requirements (angularity and parallelism) less than 0.05 mm for the offset faces the clamping means for the workpiece should be aligned using a dial gauge.

Always wear protective gloves when handling sharp-edged workpieces in order to

avoid hand injuries through cuts. Workpiece deburring should only be undertaken with sound files (snugly fitting file handles).

- When clamping workplaces in a machine vice ensure that the height of the workpiece base (parallel pieces) is so selected that the vice jaws are not deformed once the offset faces have attained the required "depth".

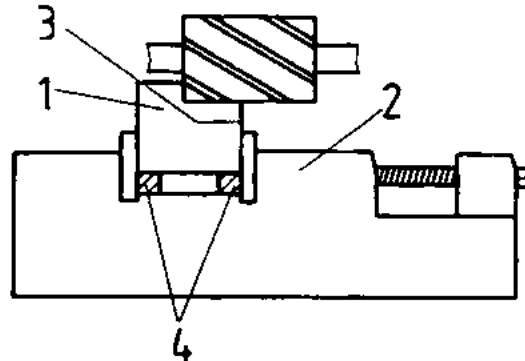

Figure 3 - Workpiece in the machine vice

- 1 - workpiece,**
- 2 - machine vice,**
- 3 - distance between the vice jaws and the milling tool, parallel pieces**

As the vice jaws are generally tempered (hardened), any contact (initial milling) with milling tools would immediately make them useless.

Furthermore, the following factors must be heeded for ensuring adherence to the accuracy requirements when clamping the work-pieces:

- **the angularity and parallelism of the offset faces depends on a clean workpiece bearing and support.**
- **the angularity and parallelism of the offset faces depends on the precise positional determination of the workpiece clamping means and the workpiece.**
- **the quality (surface finish) of the offset faces depends on the condition of the milling tools (sharp or worn), the selection of cutting values (rotational speed, rate of feed, milling depth) and on the soundness of the used milling machine (bearing distance of the milling spindle and the slideways in X-Y-Z direction).**

When clamping workpiece directly to the machine table the following preconditions must be met:

- **clean workpiece bearing and support surfaces**
- **positional determination of the workpiece in accordance with accuracy requirements (workpiece to be aligned directly to the stop strip or tongues)**
- **ensure that the workpiece is so positioned that undesired positional deviations are not possible (use of a commensurate number of workpiece clamping elements, a longitudinal stop and suitable pressure pieces, equally the necessary clamping force).**

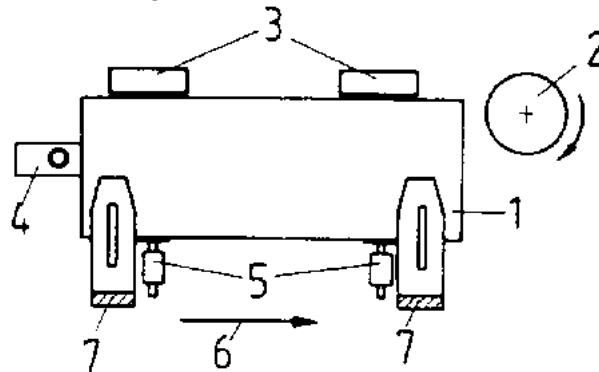

Figure 4 - Workpiece clamped on the milling table

- 1 - workpiece (front view)
- 2 - milling tool
- 3 - tongues
- 4 - stop piece
- 5 - pressure blocks
- 6 - feed direction
- 7 - clamp

Heed the following when clamping workpieces in a clamping device:

- clean device supporting surface on the machine table
- clean workpiece supporting and bearing surfaces (positional determination on the device)
- utilising all provided clamping elements with the commensurate clamping force
- determine the milling direction according to the longitudinal stop of the device
- only use properly functioning and tested devices.

When clamping the workpieces for simultaneous milling of offset faces on a portal milling machine, a two-spindle milling machine or when using gang cutters on a horizontal milling machine ensure the following:

- cleanliness when clamping the workpieces
- positional determination according to required accuracy parameters
- positional stability irrespective of the type of workpiece clamping means
- selection of cutting values according to type of material and the nature of the milling tool.

The requirements in respect of labour safety must always be heeded irrespective of the type of clamping means used when milling offset faces or the manner in which offset faces are turned out.

In order to avoid eye injuries ensure that the milling protective devices or chip catch are purposefully employed. Workpieces with burr or sharp-edged faces should only be moved wearing protective gloves or using rags in order to avoid hand injuries.

How can workpiece and workpiece clamping means with greater accuracy requirements be aligned?

What must always be heeded when clamping workpieces in order to avoid quality impairment?

Clamping tools for milling offset faces

The clamping tools must be clamped safety and soundly (vibration-free). When clamping

milling tools it is essential to heed all cleanliness requirements. Soiling of the bearing surfaces or in between the milling machine arbor collars adversely affect tensioning through deviations in true and scheduled running. Only long milling arbors should be used on the horizontal milling machine. When milling on the vertical milling machine, only use short milling arbors if possible. In this case the mill can be clamped directly to the milling spindle.

Selection and use of measuring and testing means

The following measuring and testing means are required for controlling adherence to accuracy requirements, namely:

- vernier caliper/external micrometer**
- depth vernier caliper/depth micrometer**
- bevelled edge square or try square**
- extended limit gauge**

The above items should be checked for sound working order and positioned in readiness.

The service life of measuring and testing means depends to a considerable extent on their proper usage. This denotes an extension of the time period during which the measuring result is not adversely affected by prematurely worn measuring and testing means.

Only thoroughly deburred and clean workpieces should be checked.



[Home](#)''' '''> [ar.cn.de.en.es.fr.id.it.ph.po.ru.sw](#)



Milling of Offset Faces - Course: Techniques for machining of



material. Trainees' handbook of lessons (Institut fr Berufliche Entwicklung, 14 p.)

(introduction...)



1. Purpose and importance of milling offset faces



2. Types of milling tools used



3. Preparation for milling offset faces



4. Milling offset faces

4. Milling offset faces

Setting-up the milling machine and the milling of offset faces ensues according to the following sequence of operations:

- **checking the functionality of the milling machine to be used**
- **positioning the clamping elements, tools, measuring and testing means for use**
- **checking the conformity of the workpieces with the work accompanying data sheets**
- **unclamping and setting-up the workpiece clamping means**
- **clamping the milling tool**
- **assembly and setting-up of a milling protective device and possibly also a chip catch**

- **position the milling machine table in operating direction**
- **set the cutting values and knee lowering for quick return**
- **clamp the workpiece, scratch, set the milling depth and rough milling of the offset faces**
- **dimensional inspection and setting to the desired end dimensions, final milling of the offset faces**
- **control of the dimensional accuracy in clamped condition**
- **unclamping resp. unchucking the workpiece, deburring the cutting edges, cleansing and dimensional, positional and surface roughness control**
- **if necessary, undertake commensurate corrections, otherwise mill the offset faces of all workpieces according to "position", that is to say rough and final milling ensues according to marked scale setting. Commensurately, the workpiece must lie directly adjacent to a stop. In the absence of a stop, the necessary measure (distance magnitude) would have to be set anew for each workpiece**
- **When using a gang cutter for simultaneously milling offset faces, the required distance between the gang cutter mills is attained by means of milling machine arbor collars and spacers. Determine the prescribed distance magnitude by means of a trial piece (material scrap piece)**
- **after having concluded the technique for milling offset faces, the milling machine, all tools, auxiliaries, measuring and testing means should be thoroughly cleaned.**

What must be checked prior to taking a milling machine into operation?

What does the milling direction (rate of feed) depend on when milling offset faces?

What must be heeded when handling sharp-edged workpieces?

