

[Home](#) > [ar.cn.de.en.es.fr.id.it.ph.po.ru.sw](#)



➔ **Pinned Joints - Course: Techniques of fitting and assembling component parts to produce simple units. Trainees' handbook of lessons (Institut für Berufliche Entwicklung, 17 p.)**

(introduction...)

Preliminary Remarks

Hints on Labour Safety

1. The Purpose of Pinned Joints

2. Types of Pins

3. Types of Pinned Joints

4. Stresses in Pinned Joints

5. Tools and Auxiliary Accessories

6. The Technological Steps of Making Pinned Joints

7. Undoing Pinned Joints



[Home](#) > [ar.cn.de.en.es.fr.id.it.ph.po.ru.sw](#)

Pinned Joints - Course: Techniques of fitting and assembling component parts to produce simple units. Trainees' handbook of lessons (Institut für Berufliche Entwicklung, 17 p.)

➔ **(introduction...)**

Preliminary Remarks

Hints on Labour Safety

1. The Purpose of Pinned Joints

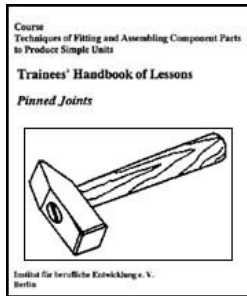

-  **2. Types of Pins**
-  **3. Types of Pinned Joints**
-  **4. Stresses in Pinned Joints**
-  **5. Tools and Auxiliary Accessories**
-  **6. The Technological Steps of Making Pinned Joints**
-  **7. Undoing Pinned Joints**

**Institut für berufliche Entwicklung e.V.
Berlin**

**Original title:
Arbeitsmaterial für den Lernenden "Stiftverbindungen"**

Author: Frank Wenghofer

First edition © IBE

**Institut für berufliche Entwicklung e.V.
Parkstraße 23
13187 Berlin**

Order No.: 90-35-3132/2



[Home](#) > [ar](#) [cn](#) [de](#) [en](#) [es](#) [fr](#) [id](#) [it](#) [ph](#) [po](#) [ru](#) [sw](#)

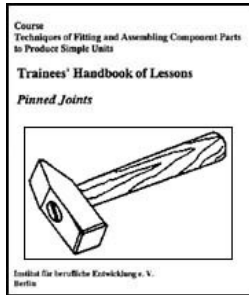

 **Pinned Joints - Course: Techniques of fitting and assembling component parts to produce simple units. Trainees' handbook of lessons (Institut für Berufliche Entwicklung, 17 p.)**

 **(introduction...)**

 **Preliminary Remarks**

 **Hints on Labour Safety**

 **1. The Purpose of Pinned Joints**

 **2. Types of Pins**

 **3. Types of Pinned Joints**

 **4. Stresses in Pinned Joints**

 **5. Tools and Auxiliary Accessories**

 **6. The Technological Steps of Making Pinned Joints**

  **7. Undoing Pinned Joints**

7. Undoing Pinned Joints

Pins in through holes can be driven out by several blows onto a drift (of a nominal diameter somewhat smaller than that of the pin). Apply the blows in the opposite direction of driving in the pin. Make sure that there is a larger hole in the support through which the pin can slip.

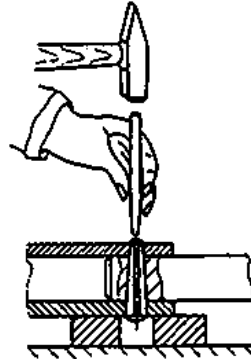

Figure 24 Undoing a pinned joint with a drift

Pins that are flush with the surface of the workpiece and have seized up or pins in blind bores must be removed by drilling. Use a drill of the nominal diameter of the pin.

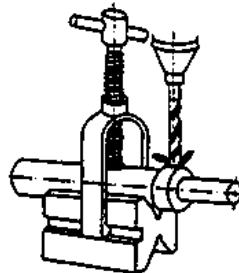

Figure 25 Removing pins with a drill

To remove grooved drive studs, apply a flat chisel sideways between the head of the grooved drive stud and the surface of the component part, and by a few hammer blows, lift the drive stud and remove it with a pair of tongs.

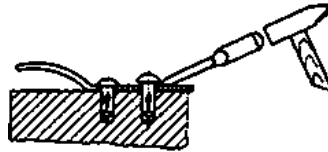

Figure 26 Undoing a grooved drive stud joint

When you remove pins from joints, make sure always to place the joint on a pad or other support that will not slip.

How can you remove a pin from a through hole?



Home > [ar](#).[cn](#).[de](#).[en](#).[es](#).[fr](#).[id](#).[it](#).[ph](#).[po](#).[ru](#).[sw](#)

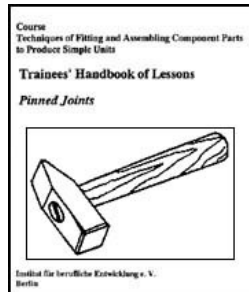

📖 Pinned Joints - Course: Techniques of fitting and assembling component parts to produce simple units. Trainees' handbook of lessons (Institut für Berufliche Entwicklung, 17 p.)

📄 (introduction...)

➔ 📄 Preliminary Remarks

📄 Hints on Labour Safety

📄 1. The Purpose of Pinned Joints

📄 2. Types of Pins

📄 3. Types of Pinned Joints

**4. Stresses in Pinned Joints****5. Tools and Auxiliary Accessories****6. The Technological Steps of Making Pinned Joints****7. Undoing Pinned Joints****Preliminary Remarks**

This material has been drawn up for the training in occupations which require a good command of assembling work, as well as basic knowledge of manual and mechanical techniques of metal working.

This material contains descriptions of the types of different joints which can be made with pins and considers these in the context of their technical function.

The main steps of making and undoing pinned joints are also described.

The questions at the end of each section are intended to help the trainees check their acquired knowledge.



[Home](#) > **[ar.cn.de.en.es.fr.id.it.ph.po.ru.sw](#)**



Pinned Joints - Course: Techniques of fitting and assembling component parts to produce simple units. Trainees' handbook of lessons (Institut fr Berufliche Entwicklung, 17 p.)



(introduction...)



Preliminary Remarks

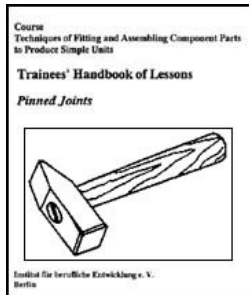

Hints on Labour Safety

1. The Purpose of Pinned Joints



2. Types of Pins



3. Types of Pinned Joints



4. Stresses in Pinned Joints



5. Tools and Auxiliary Accessories



6. The Technological Steps of Making Pinned Joints



7. Undoing Pinned Joints

Hints on Labour Safety

Generally, for accident and damage prevention those labour safety rules are valid which are also binding on the techniques of boring, drilling, countersinking and reaming. The following points, however should be emphasized:

- Use only clean, undamaged and sharp tools.
- Use hammers and punches that are in proper condition.
- Clamp workpieces securely and tightly. But never apply excessive pressure. This may damage the work.
- Drive in pins only when the component parts are securely clamped and cannot slip.
- When loosening a pinned joint, rest the workpiece on a suitable support which does not allow the components to slip.
- Put all measuring and testing means down at their proper places. Use pads,

supports and the like, in order to protect them against impact, shock and corrosion.

- It is regarded as good workmanship to keep one's workplace tidy and in good order and always to place individual parts next to their matching components.



[Home](#) > [ar](#) [cn](#) [de](#) [en](#) [es](#) [fr](#) [id](#) [it](#) [ph](#) [po](#) [ru](#) [sw](#)

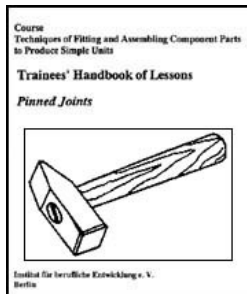

 **Pinned Joints - Course: Techniques of fitting and assembling component parts to produce simple units. Trainees' handbook of lessons (Institut für Berufliche Entwicklung, 17 p.)**

 **(introduction...)**

 **Preliminary Remarks**

 **Hints on Labour Safety**

  **1. The Purpose of Pinned Joints**

 **2. Types of Pins**

 **3. Types of Pinned Joints**

 **4. Stresses in Pinned Joints**

 **5. Tools and Auxiliary Accessories**

 **6. The Technological Steps of Making Pinned Joints**

 **7. Undoing Pinned Joints**

1. The Purpose of Pinned Joints

Pinned joints are detachable joints consisting of two or more individual component

parts with latter being connected with each other in different was, by means of standardized fasteners, such as pins.

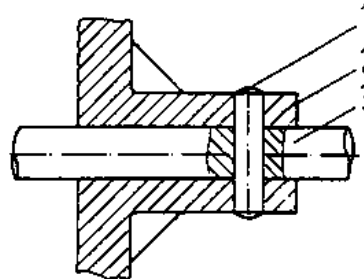

Figure 1 Pinned joint

1 pin, 2 wheel, 3 shaft

Pinned joints are made, in order

- to keep the component parts in a desired position to each another,
- to prevent the component parts from accidental loosening,
- to protect the component parts from overloads,
- to produce firm and tight joints of component parts,
- to produce joints for rotary motions.

Pins are also used to produce hinged connections, hold springs or limit the path of a moving part.

What are pinned joints?



[Home](#) > [ar](#) [cn](#) [de](#) [en](#) [es](#) [fr](#) [id](#) [it](#) [ph](#) [po](#) [ru](#) [sw](#)

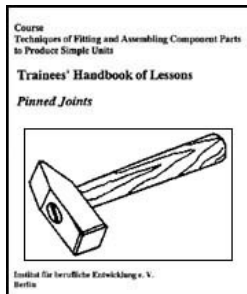

 **Pinned Joints - Course: Techniques of fitting and assembling component parts to produce simple units. Trainees' handbook of lessons (Institut für Berufliche Entwicklung, 17 p.)**

 **(introduction...)**

 **Preliminary Remarks**

 **Hints on Labour Safety**

 **1. The Purpose of Pinned Joints**

  **2. Types of Pins**

 **3. Types of Pinned Joints**

 **4. Stresses in Pinned Joints**

 **5. Tools and Auxiliary Accessories**

 **6. The Technological Steps of Making Pinned Joints**

 **7. Undoing Pinned Joints**

2. Types of Pins

Pins should be harder than the component parts which they join. Pins which are not supposed to wear should be hardened.

- Cylindrical pins

Cylindrical pins are made of bright-drawn constructional steel having tensile strength of approximately 500 MPa.

Cylindrical pins which are not hardened will be deformed permanently and cannot be used again.

There are different types of cylindrical pins. Some are hardened, some are not. There are two grades of unhardened pins with different tolerance zones, viz. m 6 and k 9. Outwardly you can know them by the shapes of their heads. A close fit of pins can be achieved by reaming the bore hole.

Sample designation: Cylindrical pin \varnothing 6 m 6 \times 20

- Nominal diameter 6 mm
- Tolerance zone m 6
- Pin length 20 mm

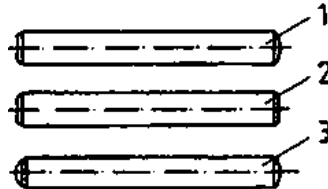

Figure 2 Cylindrical pins

1 with ISA tolerance zone m 6, 2 with ISA tolerance zone h 9, 3 with ISA tolerance zone m 6-hardened

- Taper pins

Taper pins are generally made of mild steel having tensile strength of approximately 500 MPa. Taper pins can be used several times. Their taper per unit length is mostly 1: 50. Most taper pins are inserted into tapered holes to provide safe and firm pinning. The tapered hole (which has a taper per unit length of 1:50) is produced with a taper reamer. The nominal diameter of a taper pin is measured at its narrow end. Some taper pins have external or internal threads at their opposite end. Some taper pins have external or internal threads at their opposite end.

Sample designation: Taper pin \varnothing 6 × 20

- Nominal diameter 6 mm (at thin end)
- Taper pin length 20 mm



Figure 3 Tapered pins (1: 50)

1 standard design, 2 pin with internal thread

- Grooved pins

Grooved pins are made of blank-drawn steel having tensile strength of 600 to 700 MPa. Grooved pins have three grooves arranged lengthwise at distances of 120 degrees along the circumference. Different types of grooved pins are known by the shape of their grooves.

Grooved pins are driven into simple, unreamed bore holes. A tight fit is obtained by the deformation of the edges along the grooves. Grooved pins can be used as many as 20

times.

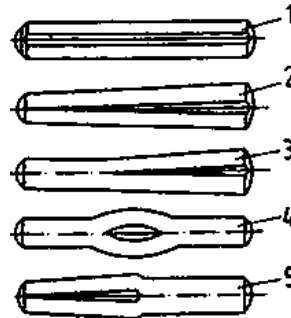

Figure 4 Grooved pins

1 cylindrical grooved pin, 2 grooved taper pin, 3 close-tolerance grooved pin, 4 center-grooved dowel pin, 5 half length reserve taper grooved dowel pin

- Grooved drive studs

Grooved drive studs are a special variety of grooved pins. They are made of steel having tensile strength of about 400 MPa, or of copper, brass or light metal. Grooved drive studs are identified by the shape of their heads.

Sample designations: Grooved drive stud, round head $\varnothing 4 \times 20$

- Nominal diameter 4 mm**
- Length without the head 20 mm**

Grooved drive stud, countersunk $\varnothing 4 \times 20$

- Nominal diameter 4 mm
- Length with the head 20 mm

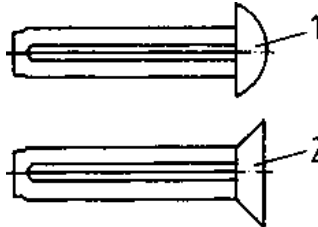

Figure 5 Grooved drive studs

1 grooved drive stud, round head, 2 grooved drive stud, countersunk

- Dowel pins (taper sleeve)

Dowel pins are made of rolled and hardened spring steel strip. They have very high strength. Oversize dowel pins are driven into simple bore holes where they respond to elastic shocks.

Dowel pins can be used as often as needed.

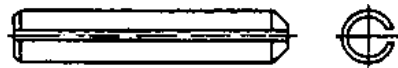
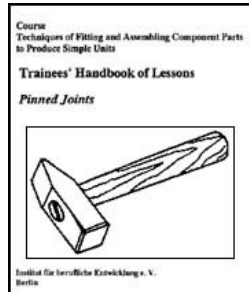

Figure 6 Dowel pin

Name the main types of pins used.



[Home](#) > [ar.cn.de.en.es.fr.id.it.ph.po.ru.sw](#)



Pinned Joints - Course: Techniques of fitting and assembling component parts to produce simple units. Trainees' handbook of lessons (Institut für Berufliche Entwicklung, 17 p.)

 **(introduction...)**

 **Preliminary Remarks**

 **Hints on Labour Safety**

 **1. The Purpose of Pinned Joints**

 **2. Types of Pins**

  **3. Types of Pinned Joints**

 **4. Stresses in Pinned Joints**

 **5. Tools and Auxiliary Accessories**

 **6. The Technological Steps of Making Pinned Joints**

 **7. Undoing Pinned Joints**

3. Types of Pinned Joints

Pinned joints are specified below as to the function the pin serves in a joint.

- Pinned joint for fastening

Pinned joints for fastening hold together two or more component parts without frictional connection. A good example of a pinned joint for fastening is a toothed wheel on a shaft where only low torques are to be transmitted. All types of pins can be used in

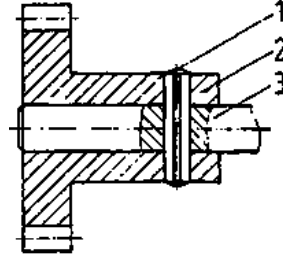
joints for fastening.**Figure 7 Pinned joint for fastening**

1 pin, 2 gear wheel, 3 shaft

- Pinned joint for driving

One part of a machine drives another part, such as in switchgears or couplings which are shifted when at rest. Cylindrical pins, close-tolerance grooved pins and dowel pins can be used in joints for driving.

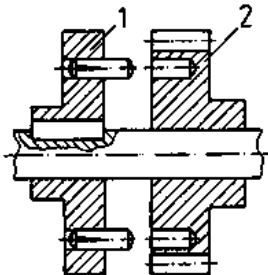
**Figure 8 Pinned joint for driving**

1 fixed component (feather key joint) with drive pins, 2 driven component

- Pinned joint for holding

Pinned joints of this type hold one component part to another component part. Cylindrical pins and grooved pins can be used in joints for holding.

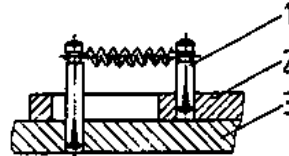

Figure 9 Pinned joint for holding

1 holding pins with spring, 2 movable part, 3 fixed part

- Pinned joint for swivelling

Pinned joints of this type connect two or more movable or rotary component parts. Cylindrical pins, grooved cylindrical pins and center-grooved dowel pins can be used in joints for swivelling.

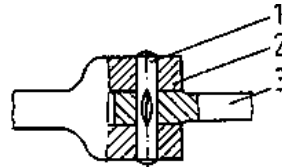

Figure 10 Pinned joint for hinging

1 hinge pin, 2 hinged component I, 3 hinged component II

- Pinned joint for fitting

Pinned joints of this type fix two component parts in a definite position relative to one another. Taper pins, close-tolerance grooved pins and cylindrical pins can be used in joints for fitting.

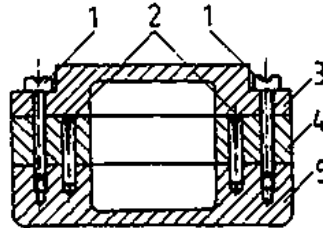

Figure 11 Pinned joint for fitting

1 screwed joint of the three component parts, 2 fitting pins, 3 component part I (lid), 4 component part II (spacer ring), 5 component part III (casing)

- Pinned joint for securing

Pinned joints of this type prevent parts of machines from becoming loose inadvertently under dynamic loads (vibration). Cylindrical pins, taper pins and grooved pins can be used in joints for securing.

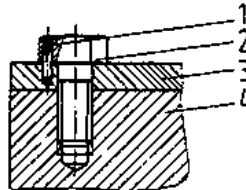

Figure 12 Pinned joint for securing

1 securing pin, 2 screw, 3 component part I, 4 component part II

- Pinned joint for shearing

Pinned joints of this type secure parts of machines which are connected directly with each other, from overloads. The pin in the joint will break when the load becomes too heavy. Thus, the component parts of the joint will not be damaged. Cylindrical pins can be used in joints for shearing.

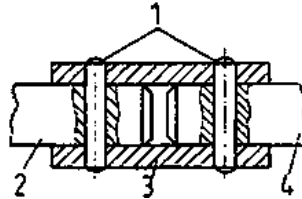

Figure 13 Pinned joint for shearing

1 shearing pins, 2 shaft I, 3 sleeve, 4 shaft II

How are pinned joints specified?

What types of pinned joints are produced?

What is typical of a pinned joint for holding?

What is typical of a pinned joint for fitting?



[Home](#) > [ar](#).[cn](#).[de](#).[en](#).[es](#).[fr](#).[id](#).[it](#).[ph](#).[po](#).[ru](#).[sw](#)

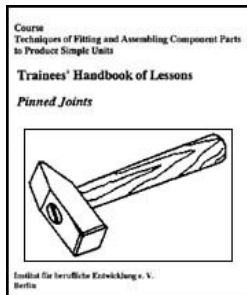

 **Pinned Joints - Course: Techniques of fitting and assembling component parts to produce simple units. Trainees' handbook of lessons (Institut für Berufliche Entwicklung, 17 p.)**

 **(introduction...)**

 **Preliminary Remarks**

 **Hints on Labour Safety**

 **1. The Purpose of Pinned Joints**

 **2. Types of Pins**

 **3. Types of Pinned Joints**

  **4. Stresses in Pinned Joints**

 **5. Tools and Auxiliary Accessories**



6. The Technological Steps of Making Pinned Joints

7. Undoing Pinned Joints

4. Stresses in Pinned Joints

Pinned joints are positive joints. The pin engages a snugly fitting pre-worked bore hole. It is kept in place by the friction that is generated between the walls of the bore hole and the pin.

External forces, if any, that act on the component parts of a joint will be transmitted from the wall of the bore hole to the surface of the pin. The pin is exposed to shearing stress by the parts of the joint. When the force is too strong, the pin will shear off just where the parts are joined.

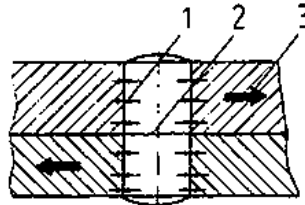

Figure 14 Stresses in Pinned Joints

1 friction, 2 shearing, 3 external forces

Identify stresses to which pins in joints are exposed.



[Home](#) > [ar.cn.de.en.es.fr.id.it.ph.po.ru.sw](#)

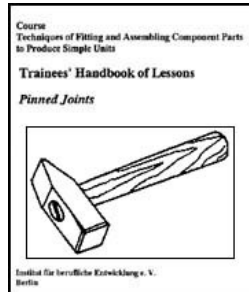

Pinned Joints - Course: Techniques of fitting and assembling component parts to produce simple units. Trainees' handbook of lessons (Institut für Berufliche Entwicklung, 17 p.)

 **(introduction...)**

 **Preliminary Remarks**

 **Hints on Labour Safety**

 **1. The Purpose of Pinned Joints**

 **2. Types of Pins**

 **3. Types of Pinned Joints**

 **4. Stresses in Pinned Joints**

 **➔ 5. Tools and Auxiliary Accessories**

 **6. The Technological Steps of Making Pinned Joints**

 **7. Undoing Pinned Joints**

5. Tools and Auxiliary Accessories

- Drills, countersinks, reamers

Various types of drills, spiral countersinks and 90° included angle countersinks, as well as cylindrical and taper reamers are used for preparing pinned joints.

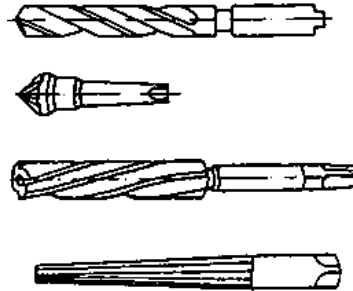

Figure 15 Drills, countersinks, reamers

- Locksmith's hammers

The pins are driven into the bore holes by means of hand-held hammers of 200 grams to 400 grams weight. Very small pins are driven in with a riveting hammer of 50 grams to 200 grams weight.

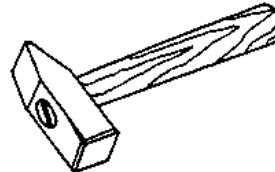

Figure 16 Locksmith's hammer

- Light-metal hammers

Aluminium hammers are used to drive in pins which might be damaged if other hammers were used.

Aluminium hammers will not cause permanent deformations to cylindrical pins or taper pins.

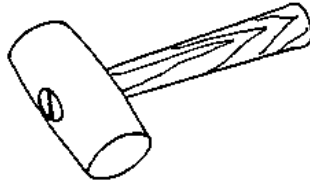

Figure 17 Light-metal hammer

- Non-ferrous metal punches

Cylindrical punches made of copper or brass are used to drive in pins which might be damaged if a locksmith's hammer were used. Punches are mostly used where access to pins is difficult.

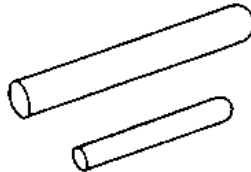

Figure 18 Non-ferrous metal punches

- Drifts

Cylindrical drifts made of non-ferrous metal or steel are used to drive pins out of their holes.

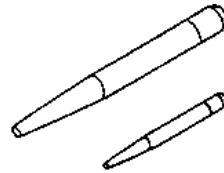

Figure 19 Drifts

- Clamping devices

Several types of clamping devices are used to clamp the component parts before and during joining operations.

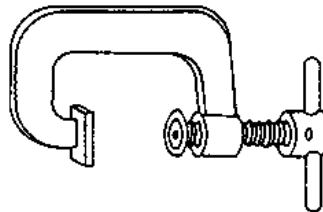

Figure 20 Clamping device

- Supports

Any kind of unhardened steel plate can be used as a support for driving in or driving out pins.

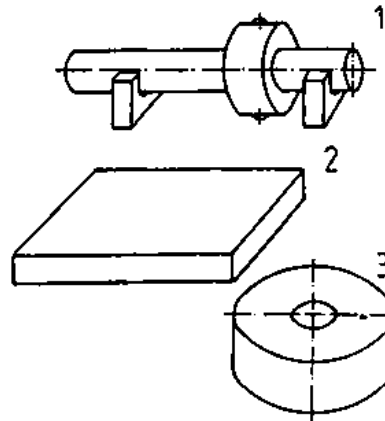

Figure 21 Supports

1 for cylindrical parts, 2 for flat parts, 3 for undoing pinned joints of flat component parts



Home > [ar.cn.de.en.es.fr.id.it.ph.po.ru.sw](#)

 **Pinned Joints - Course: Techniques of fitting and assembling component parts to produce simple units. Trainees' handbook of lessons (Institut fr Berufliche Entwicklung, 17 p.)**

 **(introduction...)**

 **Preliminary Remarks**

 **Hints on Labour Safety**

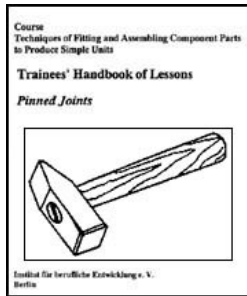

1. The Purpose of Pinned Joints
2. Types of Pins
3. Types of Pinned Joints
4. Stresses in Pinned Joints
5. Tools and Auxiliary Accessories
- ➔ 6. The Technological Steps of Making Pinned Joints
7. Undoing Pinned Joints

6. The Technological Steps of Making Pinned Joints

The technological steps of making pinned joints are different for the various types of pins used.

6.1. Joints Using Cylindrical Pins or Taper Pins

- Setting up and clamping

Clean the component parts and fit them together. Set them up and clamp them in a suitable device. While being held in the device, the component parts are to be mounted in the work-holding fixture of the boring machine.

- Drilling

Produce an undersize bore hole for cylindrical pins. The amount of undersize is removed by reaming. In general practice, the following amounts of undersize are employed for the respective nominal bore hole sizes in steel.:

N in mm	U in mm

up to 5	0.1 - 0.2
5 - 20	0.2 - 0.3
21 - 32	0.3
33 - 50	0.5

Allow a greater amount of undersize for bore holes in tough material and light metals.

N = nominal diameter

U = amount of undersize

• **Use the following formula to calculate the drill diameter:**

$$D = N - U$$

D = drill diameter

Remember the following points for bore holes over 20 mm diameter:

1. Rough-drill using drills which satisfy the following formula: $D = N - 2 \text{ mm}$
2. Countersink with a twist countersink. Use this formula: $D = N - U$

- Produce bore holes for taper pins to the nominal diameter of the taper pin:
- Read the drill speed from the respective table or calculate it, using the following general formula:
- For producing large bore holes for taper pins, taper reamers of the appropriate size are used. The bore holes are produced stepwise.

$$D = N$$

$$n = \frac{V \cdot 1000}{D \cdot 3.14}$$

$n = \text{speed}$
(min^{-1})

V = cutting speed (m/min)
 D = diameter of drill (mm)

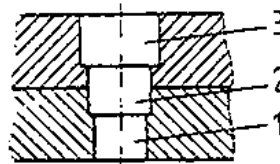

Figure 22 Drilling steps (1-2-3)

Stepped bore holes:

Calculate the diameter of the drill from the taper per unit length:

A taper per unit length of 1:50 means that the diameter is reduced by 1 mm for every 50 mm of length.

Example:

Produce a joint of two component parts having an overall thickness of 150 mm, use a taper pin of 20 mm diameter.

What steps will you drill?

Answer	Diameter	Depth
1st bore hole	∅ 20 mm	150 mm through hole
2nd bore hole	∅ 21 mm	100 mm

3rd bore hole || \varnothing 22 mm || 50 mm

What holes will you drill for a cylindrical pin having a diameter of 26 mm?

How will you produce bore holes for taper pins?

- Countersinking

Using a 90° included angle countersink, countersink the bore hole on both ends 0.2 mm larger than the nominal diameter. This removes the burr from the hole.

$$D_S = N + 0.2 \text{ mm}$$

where

D_S = Countersunk diameter

- Reaming

Make the bore hole larger by reaming. Use a cylindrical or taper reamer that fits the type and size of the pin which is to be used.

When reaming a hole for a taper pin joint, test the fit of the pin before you drive it in.

With the force of your thumb, push the taper pin into the reamed hole. Clean the hole before you insert the pin. The upper edge of the pin should stick out above the edge of the hole by a length that depends on the nominal diameter of the pin. Where the size is that specified in the table below, apply two or three blows with a hammer to drive in the pin.

Testing the fit of taper pins having taper per unit length of 1: 50

Nominal diameter of the taper pin (mm)	Size for testing the fit (mm)
5	3
6	4 - 5
8	5 - 6
10	8

Remember:

The length of the taper pin you want to use must be 2 mm shorter than the thickness of all parts of the proposed joint.

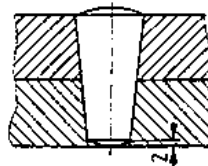

Figure 23 Accurate fit of a taper pin

Thus, the pin can be driven out with a drift from the opposite end. The drift will not slip and the one end of the pin cannot be mistaken for the other.

The upper edge of the pin is flush with the edge of the bore in the upper component part.

Where no taper pin of the required size is available, saw a longer pin to the dimension you need. Always saw off the thicker end of the pin. Do not change the nominal diameter of the pin. Produce a new head by filing.

What type of countersink will you use to deburr a bore hole?

What should be taken into consideration when reaming a taper pin hole?

What condition must be satisfied with respect to the length of a taper pin?

How will you shorten the length of a taper pin?

- Cleaning the bore hole

Use compressed air or a brush to remove chips and any remaining fluid from the bore hole after reaming.

- Pinning

Apply a thin film of grease to the pin and drive it in by several blows with an aluminium hammer. Proceed from the end at which you applied the reamer.

Use a non-ferrous metal punch and a locksmith's hammer to drive the pin in when access to its location is difficult.

- Checking

Check the pin for tight fit in the hole and that the upper edge of the pin is flush with the surface of the component part of the joint.

How should a pin fit the hole?

What are the steps of producing a joint using a cylinder pin?

6.2. Joints Using Grooved Pins and Dowel Pins

- Setting up and clamping

Clean the component parts and fit them together. Set them up and clamp them in a suitable device.

While being held in the device, the component parts are to be mounted in the work-holding fixture of the drilling machine.

- Drilling

Produce a bore hole equal to the nominal diameter of the pin.

$$D = N$$

- Countersinking

Use a 90-degree included angle countersink and countersink the bore hole at both ends or remove the burr with a triangular reamer.

$$D_s = N + 0.2 \text{ mm}$$

- Cleaning the bore hole

Use compressed air or a brush to remove chips and any remaining fluid from the bore hole.

- Pinning

Apply a thin film of grease to the pin and drive the pin in by several slight blows with a hammer. Proceed from the end at which you applied the drill.

- Checking

Check the pin for tight fit in the hole and that the upper edge of the pin head is flush

with the surface of the component part of the joint.

What are the differences in the sequences of operations when producing a joint by means of a grooved pin on one hand and a cylindrical or taper pin on the other hand?

