

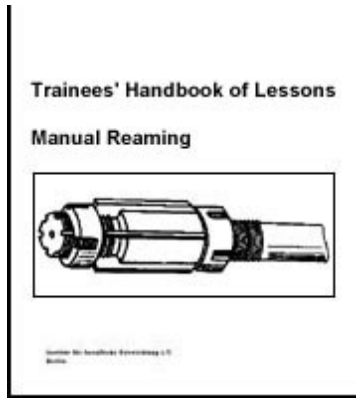





- ➔ **Manual Reaming - Course: Technique for manual working of materials. Trainees' handbook of lessons (Institut für Berufliche Entwicklung, 18 p.)**
- 📄 **(introduction...)**
 - 📄 **1. Purpose of reaming**
 - 📄 **2. Tools for reaming**
 - 📄 **3. Construction of hand reamers**
 - 📄 **4. Operation of reamers**
 - 📄 **5. Technological process of reaming**
 - 📄 **6. Checking of straight reamers**
 - 📄 **7. Indication of fits on the straight reamer**
 - 📄 **8. Special recommendations for making conical bore holes true to size**



- 📖 **Manual Reaming - Course: Technique for manual working of materials. Trainees' handbook of lessons (Institut für Berufliche Entwicklung, 18 p.)**
- ➔ 📄 **(introduction...)**
- 📄 **1. Purpose of reaming**
 - 📄 **2. Tools for reaming**
 - 📄 **3. Construction of hand reamers**





-  **4. Operation of reamers**
-  **5. Technological process of reaming**
-  **6. Checking of straight reamers**
-  **7. Indication of fits on the straight reamer**
-  **8. Special recommendations for making conical bore holes true to size**

**Institut fr berufliche Entwicklung e.V.
Berlin**

**Original title:
Arbeitsmaterial fr den Lernenden
"Reiben von Hand"**

Author: Frank Wenghfer

First edition © IBE

**Institut fr berufliche Entwicklung e.V.
Parkstrae 23
13187 Berlin**

Order No.: 90-35-3108/2





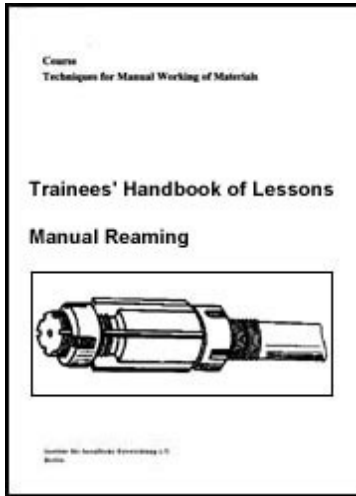





[Home](#) "" "" "" "" "" > [ar](#).[cn](#).[de](#).[en](#).[es](#).[fr](#).[id](#).[it](#).[ph](#).[po](#).[ru](#).[sw](#)



 **Manual Reaming - Course: Technique for manual working of materials. Trainees' handbook of lessons (Institut für Berufliche Entwicklung, 18 p.)**

 **(introduction...)**

-   **1. Purpose of reaming**
-  **2. Tools for reaming**
-  **3. Construction of hand reamers**
-  **4. Operation of reamers**
-  **5. Technological process of reaming**
-  **6. Checking of straight reamers**
-  **7. Indication of fits on the straight reamer**
-  **8. Special recommendations for making conical bore holes true to size**

1. Purpose of reaming

Reaming is applied after drilling in order to

- **make bore holes true to size, e.g. for plain pin connections (in ranges from hundredth to thousandth millimetres)**
- **fine-finish the inside surfaces of bore holes**
- **align offset bores with riveted joints**
- **make conical bore holes for machine taper or taper pin joints**

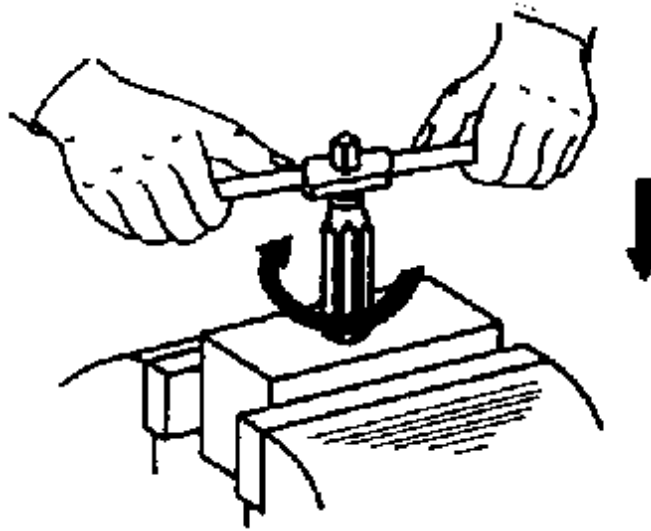
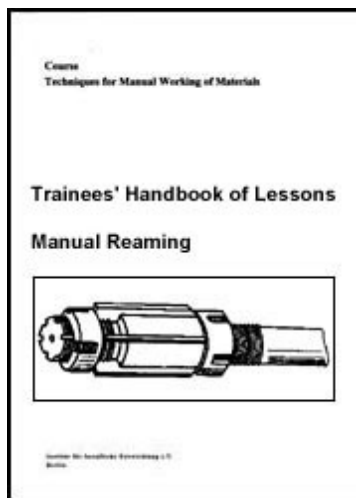

Figure 1 - Reaming

Reaming always necessitates the existence of a bore hole.



[Home](#) > [ar](#) [cn](#) [de](#) [en](#) [es](#) [fr](#) [id](#) [it](#) [ph](#) [po](#) [ru](#) [sw](#)



 **Manual Reaming - Course: Technique for manual working of materials. Trainees' handbook of lessons (Institut für Berufliche Entwicklung, 18 p.)**

 **(introduction...)**

 **1. Purpose of reaming**

 **➔ 2. Tools for reaming**

 **3. Construction of hand reamers**

 **4. Operation of reamers**

 **5. Technological process of reaming**

-  **6. Checking of straight reamers**
-  **7. Indication of fits on the straight reamer**
-  **8. Special recommendations for making conical bore holes true to size**

2. Tools for reaming

Tools for reaming are the reamers. According to the mode of operation, there are hand and machine reamers which may be provided with straight or spiral-fluted cutting portion.

Reamers are adapted to their respective purpose.

Shell reamers:

They are used for large bore hole diameters; only the cutting portion consists of high-grade tool steel, the shank is made of ordinary steel.

Various cutting parts can be put on one shank.

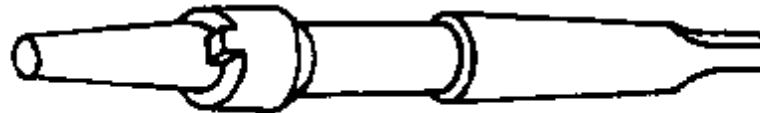

Figure 2 - Shell reamer

Readjustable reamers:

Used for reworking of worn out bore holes as well as for making non-standardized bore holes true to size. They can be adjusted to various diameters within a small range.



Figure 3 - Readjustable reamer

Taper reamers:

Used in sets (roughing reamer, semi-finishing reamer and finishing reamer) for large machine taper joints. For smaller taper pin joints, individual reamers of various nominal diameters are used.

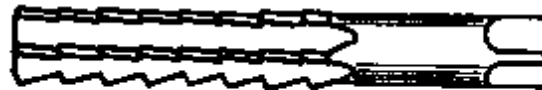

1

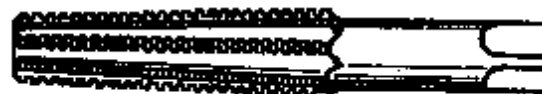

2



3

Figure 4 - Serial taper reamers

- 1 - Roughing reamer
- 2 - Semi-finishing reamers
- 3 - Finishing reamer

Structural reamers:

Used for aligning offset bore holes when making riveted joints; structural reamers are spiral-fluted, big-taper reamers of a strong cutting effect.



Figure 5 - Structural reamer



[Home](#) > [ar](#) [.cn](#) [.de](#) [.en](#) [.es](#) [.fr](#) [.id](#) [.it](#) [.ph](#) [.po](#) [.ru](#) [.sw](#)

 **Manual Reaming - Course: Technique for manual working of materials. Trainees' handbook of lessons (Institut fr Berufliche Entwicklung, 18 p.)**

 **(introduction...)**

 **1. Purpose of reaming**

 **2. Tools for reaming**

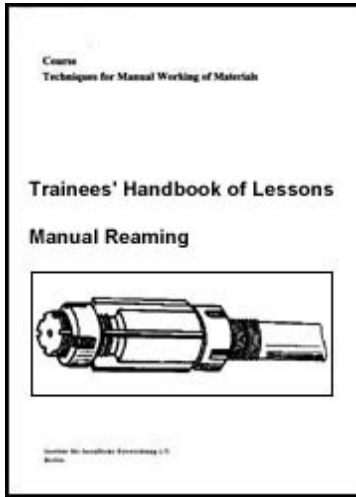

- ➔ 3. Construction of hand reamers
- ➔ 4. Operation of reamers
- ➔ 5. Technological process of reaming
- ➔ 6. Checking of straight reamers
- ➔ 7. Indication of fits on the straight reamer
- ➔ 8. Special recommendations for making conical bore holes true to size

3. Construction of hand reamers

Straight reamer:

It consists of a cutting portion with axial, straight or spiral-fluted peripheral cutting edges and the shank which is equipped with a square (for being received by a tap wrench).

The end of the straight reamer is tapered - the taper lead. At the taper lead, the greatest quantity of chips is taken off. The nominal diameter is at the straight part of the cutting portion.

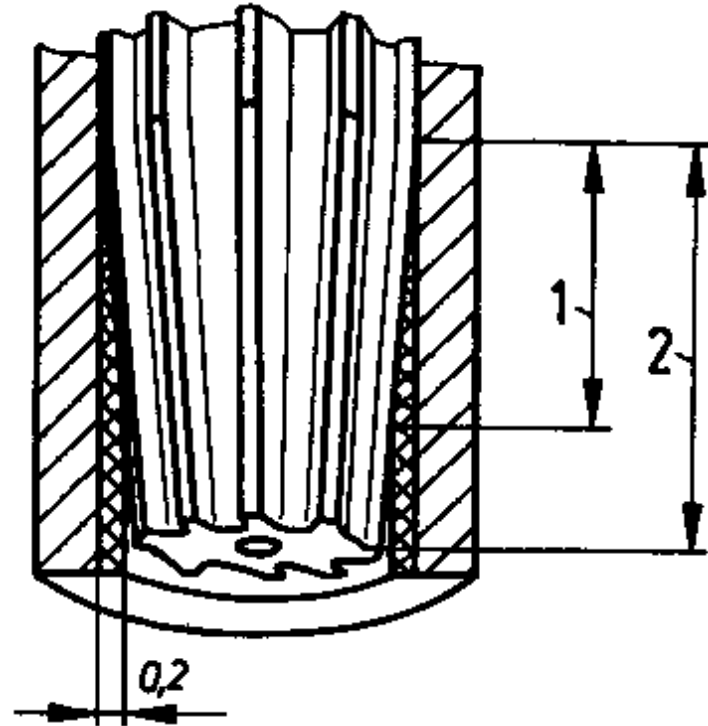

Figure 6

- 1 - Effective length of cutting portion**
- 2 - Taper lead**

For better guiding and aligning of the reamer in the bore hole, the taper lead is longer than that of a machine reamer the guiding of which is guaranteed by the machine spindle.

Conclusion:

The hand reamer can only be used with through holes, because a blind hole cannot be completely cylindrically reamed due to the long taper lead.

Taper reamer:

It consists of a long, conical cutting portion of a certain conicity (for instance 1:50); the shank is equipped with a square so that it can be received by a tap wrench. The nominal diameter is at the beginning of the cutting portion. Taper reamers belonging to a set (serial taper reamers) have differently shaped cutting portions with special chip-breaking grooves, because they must be able to remove great quantities of chips. Only the finishing reamer leads to the required surface quality.

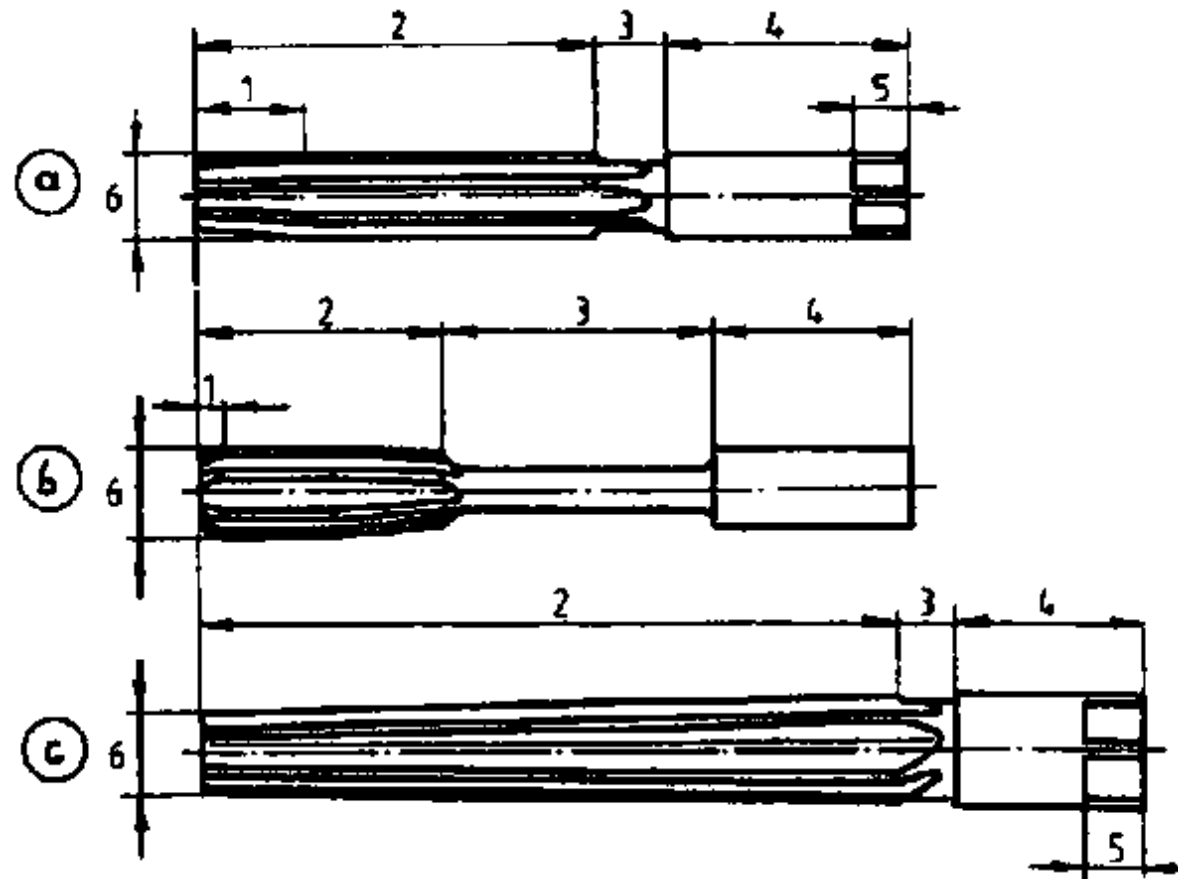

Figure 7 - Comparison of reamers in use

- a straight reamer**
- b machine reamer**
- c Taper reamer**
- 1 Taper lead**
- 2 Cutting portion**
- 3 Neck**
- 4 Shank**
- 5 Square**
- 6 Nominal diameter**

What is the task of the taper lead at the straight reamer?

Why must the straight hand reamer have a relatively long taper lead?

Why is the straight machine reamer allowed to have a relatively short taper lead?

Why can the straight hand reamer be used only with through holes?



[Home](#) > [ar](#).[cn](#).[de](#).[en](#).[es](#).[fr](#).[id](#).[it](#).[ph](#).[po](#).[ru](#).[sw](#)

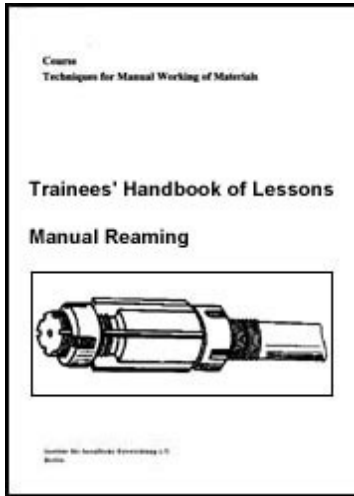

materials. Trainees' handbook of lessons (Institut für Berufliche Entwicklung, 18 p.)

📄 *(introduction...)*

📄 **1. Purpose of reaming**

📄 **2. Tools for reaming**

📄 **3. Construction of hand reamers**

➔ 📄 **4. Operation of reamers**

📄 **5. Technological process of reaming**

📄 **6. Checking of straight reamers**

📄 **7. Indication of fits on the straight reamer**

📄 **8. Special recommendations for making conical bore holes true to size**

4. Operation of reamers

Reamers take off material at the circumference of the cylindrical bore hole. This happens when they are turned with the help of a tap wrench with little pressure from above in clockwise direction in the bore hole.

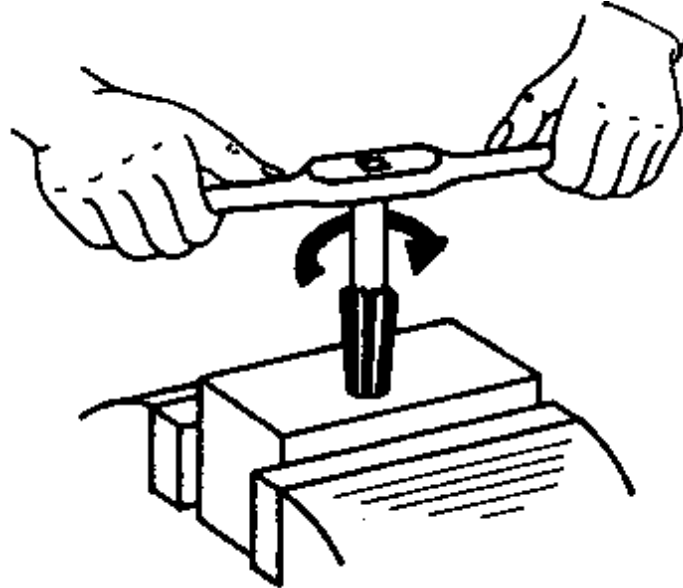

Figure 8 - Reaming

In doing so, lubricating and cooling agents must be fed.

Straight and spiral-fluted reamers cannot carry off any chips during the process, the chips remain in the chip grooves filling them after a short time.

Conclusion:

Especially with longer bores, reamers must be taken out and cleaned during the reaming process, otherwise they will become jammed and break.

Why must reamers - after the process has begun - not be turned in reverse (anticlockwise) direction?

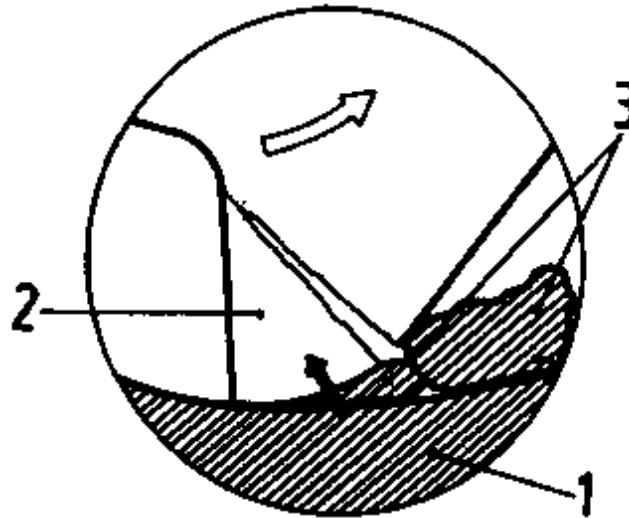

Figure 9 - Chipping of the cutting edge when turning the reamer in reverse direction

- 1 - Workpiece,**
- 2 - Cutting edge,**
- 3 - Chips**

With spiral-fluted reamers - in contrast to the drill - the hand of the helix is opposite to the direction of rotation (sole exception: the structural reamer) in order to prevent the reamer from being drawn into the bore.

Such reamers are used, if there are pockets or grooves in the bore (feather or oil grooves).

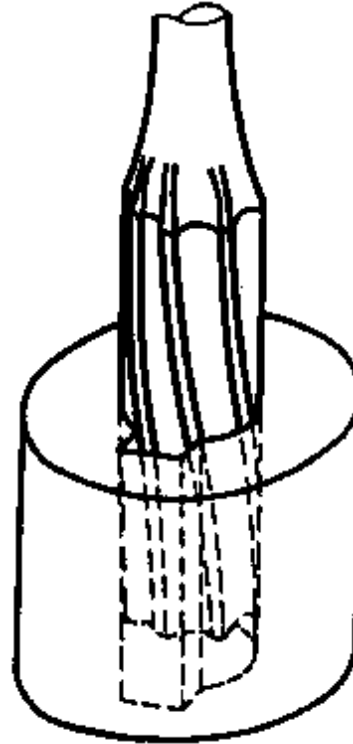

Figure 10 - Spiral-fluted reamer applied to a bore hole with feather groove

What happens, if with reaming a bore with feather groove a straight-fluted reamer is used?



[Home](#) > [ar](#).[cn](#).[de](#).[en](#).[es](#).[fr](#).[id](#).[it](#).[ph](#).[po](#).[ru](#).[sw](#)

 **Manual Reaming - Course: Technique for manual working of**

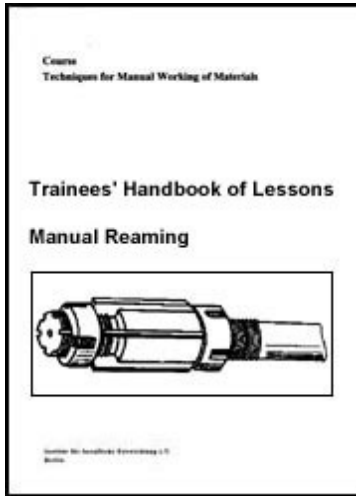

materials. Trainees' handbook of lessons (Institut für Berufliche Entwicklung, 18 p.)

 *(introduction...)*

 **1. Purpose of reaming**

 **2. Tools for reaming**

 **3. Construction of hand reamers**

 **4. Operation of reamers**

 **→ 5. Technological process of reaming**

 **6. Checking of straight reamers**

 **7. Indication of fits on the straight reamer**

 **8. Special recommendations for making conical bore holes true to size**

5. Technological process of reaming

With making a cylindrical bore true to size as well as with the preparation of plain pin connections, the following steps are required:

5.1. Clamping

The workpieces, as far as possible, should be clamped in such way, that they can be drilled, counterbored/countersunk and reamed in succession without the clamping being loosened in between.

5.2. Scribing/prick-punching

This operation has to be carried out as described under “Drilling and counterboring/countersinking”; it can also be done before clamping.

5.3. Drilling

Since the reamer must remove material from the inside of the bore, the bore must be made smaller than the nominal diameter of the bore true to size indicates. This difference is called "undersize"

Empirical values for undersizes of bore holes in steel are:

N in mm	U in mm
up to 5	0.1 - 0.2
5 - 20	0.2 - 0.3
21 - 32	0.3
33 - 50	0.5

N = nominal diameter

U = undersize

With tough materials and light metal, the undersizes are larger than with steel.

The diameter (D) of the drill is calculated by the following formula:

$$D = N - U$$

D = diameter of the drill

The calculation of the rotational speed (n) of the drill is explained in the lesson "Drilling and counterboring/counter-sinking"

General formula:

$$n = \frac{V \cdot 1000}{D \cdot \pi}$$

V = cutting speed (approx. 22 m/min)

$\pi = 3.14$

5.4. Countersinking

The bore must be spot-faced by a 90° countersink on either side. In doing so, the diameter of the countersinking (D_S) is to be calculated with the help of the following formula:

$$D_S = N + 0.2 \text{ m}$$

D_S = diameter of the countersinking

The rotational speed for countersinking bores up to a diameter of 10 mm can be approx. 350 r.p.m. with larger bore holes it must be lower.

$$n \approx 350 \text{ r.p.m}$$

5.5. Reaming

With through bores, always hand reamers can be used; for bores with pockets, the reamer must be spiralfluted (blind holes must be reamed by machine reamers only.) Tap wrenches are used as auxiliary means

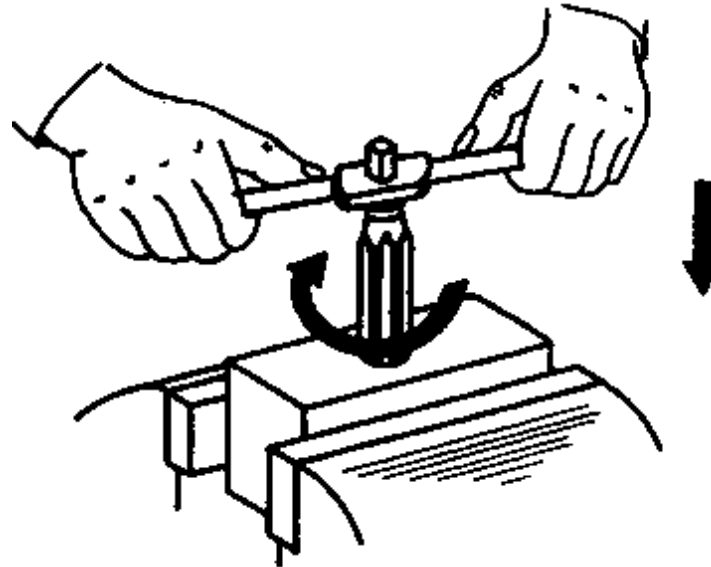

Figure 11 - Reaming operation - clockwise rotation

Lubricating and cooling agents are to be seen from the following table:

Steel:	cutting oil
Aluminium alloys:	spirit
Chromium-nickel alloys:	colza oil, petroleum

5.6. Cleaning the bore

After reaming, the chips and remaining oil have to be removed from the bore with the help of compressed air or brush.

5.7. Checking/pinning

Standardized bore holes which are made true to size are checked with the respective plug limit gauge, nonstandardized bore holes true to size may be checked with the help

of an internal micrometer.

Pin connections are checked as to functioning after the pins are set in.

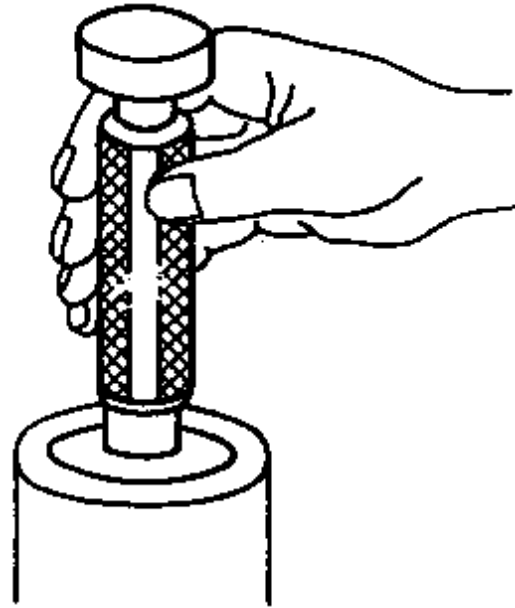

Figure 12 - Testing by plug limit gauge



[Home](#) > [ar.cn.de.en.es.fr.id.it.ph.po.ru.sw](#)

 **Manual Reaming - Course: Technique for manual working of materials. Trainees' handbook of lessons (Institut fr Berufliche Entwicklung, 18 p.)**

 **(introduction...)**

 **1. Purpose of reaming**

 **2. Tools for reaming**

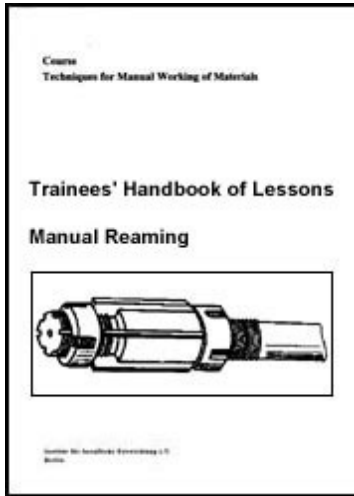

- 3. Construction of hand reamers
- 4. Operation of reamers
- 5. Technological process of reaming
- ➔ 6. Checking of straight reamers
- 7. Indication of fits on the straight reamer
- 8. Special recommendations for making conical bore holes true to size

6. Checking of straight reamers

Mostly, these reamers have an even number of cutting edges two of which are facing each other. As a result, the diameter of the reamer can be determined by an external micrometer. However, this is not very useful.

Straight reamers produce a bore hole within a set range of accuracy.

One cannot infer the exact diameter of the bore from the exact diameter of the reamer.

Faults with the process of reaming or dull reamers may cause deviations of several hundredth of a millimeter.

Therefore, a test bore must always be made: on the basis of the checked bore it can be found out whether the respective reamer can be used or not.

Note

Readjustable reamers must be adjusted by a ring gauge or external micrometer

before reaming; then, a test bore has to be made.



[Home](#) > [ar.cn.de.en.es.fr.id.it.ph.po.ru.sw](#)

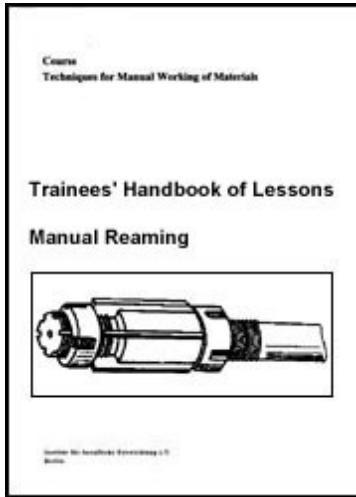

- 📖 **Manual Reaming - Course: Technique for manual working of materials. Trainees' handbook of lessons (Institut für Berufliche Entwicklung, 18 p.)**
- 📄 **(introduction...)**
- 📄 **1. Purpose of reaming**
- 📄 **2. Tools for reaming**
- 📄 **3. Construction of hand reamers**
- 📄 **4. Operation of reamers**
- 📄 **5. Technological process of reaming**
- 📄 **6. Checking of straight reamers**
- ➔ 📄 **7. Indication of fits on the straight reamer**
- 📄 **8. Special recommendations for making conical bore holes true to size**

7. Indication of fits on the straight reamer

In assembly and interchangeable manufacture, a system of standardization of fits is internationally accepted:

It classifies fits in definite ranges of accuracy. Such range is called range of tolerance and is limited by a maximum limit and a minimum limit.

ISA SYSTEM OF TOLERANCES AND FITS

Example of a bore true to size:

(This designation is indicated on the shank of the reamer.)

8K7

8 = nominal diameter 8 mm

K7 = range of tolerance

**The tolerance limits can be 8.005 mm - maximum limit
taken from a relevant table: 7.990 mm - minimum limit**

Conclusion:

**By a reamer of 8K7 a bore true to size can be made within the range of 7.990 mm
and 8.005 mm.**

**For the operation itself knowledge of the maximum and minimum limits is not required if
the fit is known.**

Note:

**The designation of the fit is identical on the tools and on the testing equipment -
in connection with a certain tool the corresponding testing instrument must be
used.**

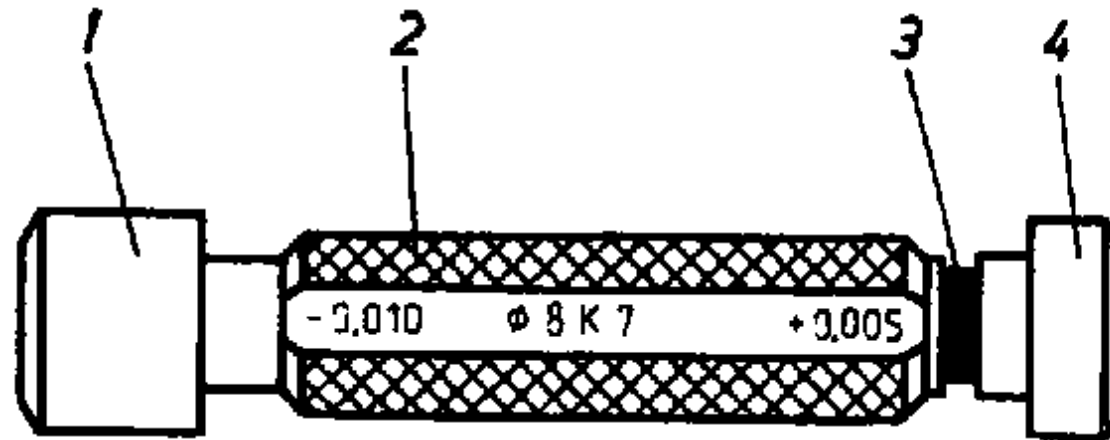

Figure 13 - Plug limit gauge 8K7

- 1 - Go end (minimum size),**
- 2 - Handle with indication of fit,**
- 3 - Red colour ring indicating the not-go end,**
- 4 - Not-go end (maximum size)**

What is the designation of the plug limit gauge by which a bore shall be checked that was reamed by a reamer marked 8K7?

By the plug limit gauge it can only be tested whether or not the bore is within the fixed range of tolerance - the exact diameter cannot be determined by the plug limit gauge.

Exercise:

The following tool and machine values have to be determined for making a cylindrical through hole in steel true to size and of a diameter of 8K7:

Diameter of the drill (D):

Diameter of the drill (D): _____Rotational speed (n): _____Countersinking diameter (D_S): _____Rotational speed (n): _____

Enter the individual steps of operation and the values calculated for this bors in the below table; fill in blank spaces:

No.	Operation	Tools, testing and auxiliary equipment	Tool and machine values
1.	Clamping		-
2.	Scribing/ prick-punching		-
3.	Drilling	Drill vernier caliper lubricating and cooling agents	$D =$ $n =$
4.	Countersinking	Countersink vernier caliper	$D_S =$ $n =$
5.	Reaming	Hand reamer tap wrench cutting oil	8K7
6.	Cleaning		-
7.	Testing	Plug limit gauge	

This form of table can be used for preparing the practical exercises in reaming.









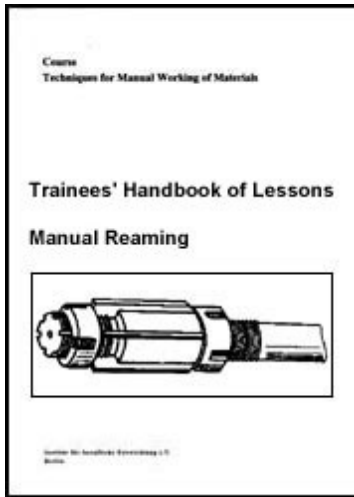

Exception

This sequence of operations does not apply to the use of structural reamers - the reaming of offset holes is no fitting operation.



[Home](#) > [ar](#).[cn](#).[de](#).[en](#).[es](#).[fr](#).[id](#).[it](#).[ph](#).[po](#).[ru](#).[sw](#)



-  **Manual Reaming - Course: Technique for manual working of materials. Trainees' handbook of lessons (Institut für Berufliche Entwicklung, 18 p.)**
-  **(introduction...)**
 -  **1. Purpose of reaming**
 -  **2. Tools for reaming**
 -  **3. Construction of hand reamers**
 -  **4. Operation of reamers**
 -  **5. Technological process of reaming**
 -  **6. Checking of straight reamers**
 -  **7. Indication of fits on the straight reamer**
 -  **8. Special recommendations for making conical bore holes true to size**

8. Special recommendations for making conical bore holes true to size

Conical bore holes are required if machine taper or taper pin connections shall be made. With large bore holes serial taper reamers cannot be used without special preparation; such bore holes must be cylindrically predrilled in steps. The calculation of the diameter of the drill is to be derived from the conicity:

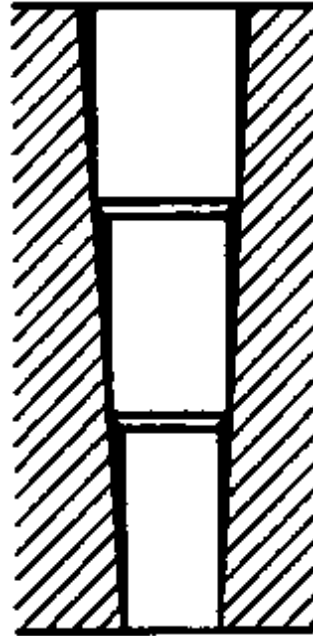

Figure 14 - Taper bore predrilled in steps

A conicity of 1:50 means:

Over a length of 50 mm the diameter changes by 1 mm.

Example:

A taper pin of a nominal diameter of 6 mm and a length of 50 mm has a diameter of 7 mm at its upper end.

With making a taper pin connection, step no. 7 - pinning and checking - is characterized by the preliminary fitting-in of the pin:

After reaming, the pin is pushed by the thumb into the cleaned bore hole. The upper edge of the pin roust project over the edge of the bore by an amount depending on the nominal diameter. If the measure achieved is identical with the empirical value (below

table), the pin is driven in by two or three short strokes.

Empirical values for the preliminary fitting-in of taper pins of a conicity of 1:50

Nominal diameter of the taper pin (in mm)	Measure for the preliminary fitting-in (in mm)
5	3
6	4 - 5
8	5 - 6
10	8

The following condition applies to the length of the taper pin (illustration):

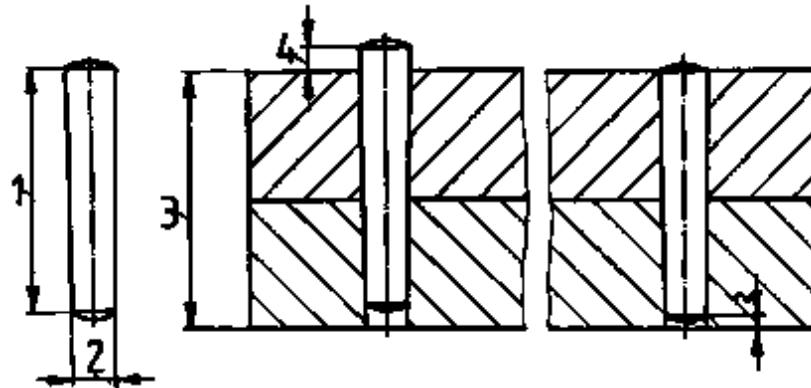

Figure 15 - Conditions of the fitting in of taper pins

- 1 - Length of the taper pin**
- 2 - Nominal diameter of the taper pin**
- 3 - Thickness of the parts to be connected (total)**
- 4 - Measure for prefitting**

It must be 2 mm shorter than the total of the thicknesses of all parts to be

connected.

If this condition is observed, the pin - after being driven in - sits in the bore hole in such a way that a drift can be applied from the opposite side in order to remove the pin. The upper edge of the pin is at level with the edge of the bore hole of the upper portion.

Plain pins and taper pins mostly consist of unhardened steel. Therefore, for driving the pins in, aluminium hammers or locksmith's hammers are used in connection with a drift of non-ferrous metal.

Why must the locksmith's hammer not hit the pin directly?

How can the pin connection be undone?

For making a taper pin joint, the length of the taper pin is important.

What condition must be observed when determining the length?

What instructions concerning labour safety have to be observed with reaming?

