

➔ **Scraping of plane surfaces - Course: Technique for manual working of materials. Trainees' handbook of lessons (Institut fr Berufliche Entwicklung, 14 p.)**

(introduction...)

- 1. Purpose of scraping**
- 2. Tools for scraping**
- 3. Purpose of inking**
- 4. Testing and auxiliary equipment for inking**
- 5. Operation of scraping**
- 6. Technological process of planing a plane surface**
- 7. Additional recommendations**



[Home](#) > [ar.cn.de.en.es.fr.id.it.ph.po.ru.sw](#)

Scraping of plane surfaces - Course: Technique for manual working of materials. Trainees' handbook of lessons (Institut fr Berufliche Entwicklung, 14 p.)

➔ **(introduction...)**

- 1. Purpose of scraping**
- 2. Tools for scraping**
- 3. Purpose of inking**
- 4. Testing and auxiliary equipment for inking**
- 5. Operation of scraping**
- 6. Technological process of planing a plane surface**

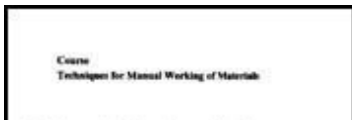

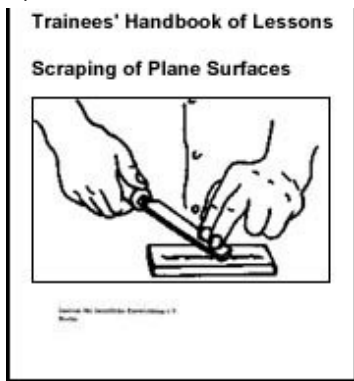

7. Additional recommendations

**Institut fr berufliche Entwicklung e.V
Berlin**

**Original title:
Arbeitsmaterial fr den Lernenden
"Schaben ebener Fichen"**

Author: Frank Wenghfer

First edition © IBE

**Institut fr berufliche Entwicklung e.V.
Parkstrae 23
13187 Berlin**

Order No.: 90-35-3106/2







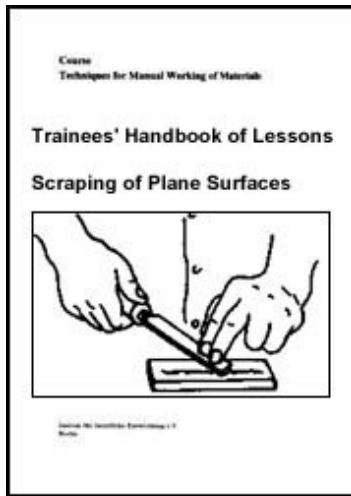

[Home](#) > [ar](#) [cn](#) [de](#) [en](#) [es](#) [fr](#) [id](#) [it](#) [ph](#) [po](#) [ru](#) [sw](#)

 **Scraping of plane surfaces - Course: Technique for manual working**



of materials. Trainees' handbook of lessons (Institut für Berufliche Entwicklung, 14 p.)

 *(introduction...)*

- ➔  **1. Purpose of scraping**
-  **2. Tools for scraping**
-  **3. Purpose of inking**
-  **4. Testing and auxiliary equipment for inking**
-  **5. Operation of scraping**
-  **6. Technological process of planing a plane surface**
-  **7. Additional recommendations**

1. Purpose of scraping

Scraping is fine finishing of largely rough-finished in order to smooth them, to correct defects of the form or to provide them with a pattern.

Scraping is highly qualified manual work and is applied only if the respective material cannot be fine-finished by machines.



Figure 1 - Scraping

Normally, plane surfaces should be finished by surface grinding, curved surfaces and bore holes by precision boring or honing. By scraping mainly sliding parts of machines are worked such as carriages and slide bearings which must show a high surface quality. With sliding surfaces, the recesses achieved have a positive effect since they enable an accumulation of lubricating oil.

An even lubricant film is required to reduce friction at these surfaces. By scraping also oil grooves are placed in domed brasses.

What kinds of workpieces are mainly treated by scraping?

When is the method of scraping applied?



[Home](#) > [ar](#).[cn](#).[de](#).[en](#).[es](#).[fr](#).[id](#).[it](#).[ph](#).[po](#).[ru](#).[sw](#)

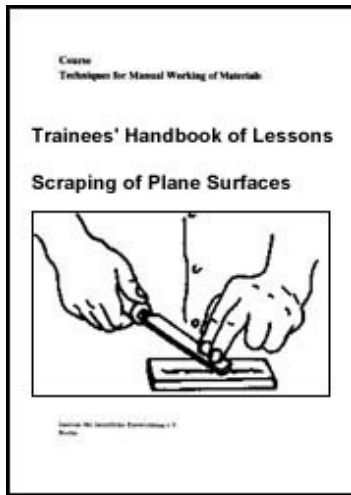

 **Scraping of plane surfaces - Course: Technique for manual working of materials. Trainees' handbook of lessons (Institut fr Berufliche Entwicklung, 14 p.)**

 **(introduction...)**

 **1. Purpose of scraping**

  **2. Tools for scraping**

 **3. Purpose of inking**

 **4. Testing and auxiliary equipment for inking**

 **5. Operation of scraping**

 **6. Technological process of planing a plane surface**

 **7. Additional recommendations**

2. Tools for scraping

Scrapers consist of high-grade, mostly alloyed tool steel; after drawing-out they are hardened, ground and whetted. The selection of the scraper depends on the shape of the surfaces to be worked.

Flat scrapers

Pushing scrapers for pre-scraping and spot scraping of plane surfaces, suitable for

removing larger quantities of chips;



Figure 2 - Flat scraper

Pulling scrapers

Scrapers for finishing and pattern scraping of plane surfaces, suitable only for removing smallest quantities of chips.

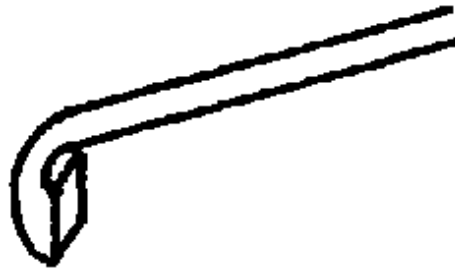

Figure 3 - Pulling scraper

Half-round scrapers

Tools in the form of solid or hollow scrapers for scraping curved surfaces or bore holes.



Figure 4 - Half-round scraper

Three-square scrapers

Tools in the form of solid or hollow scrapers for scraping curved surfaces or bore holes as well as for deburring edges

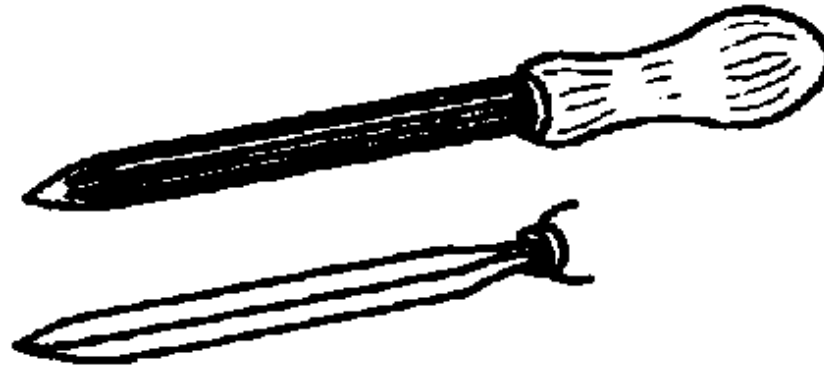

Figure 5 - Three-square scraper

Note:

The cutting-wedge angle of the scraper has to be ground according to the material; it is between 70° and 90°.

After having been given an angle by grinding the scraper must be deburred on an oiled whetstone, so that it remains sharp for a longer time and does not become

dull too soon.

In doing so, the scraper has to be drawn over the oilstone from either side of the cutting edge alternately and in an inclined position till the burr - which this way is bent for several times - is neatly removed.

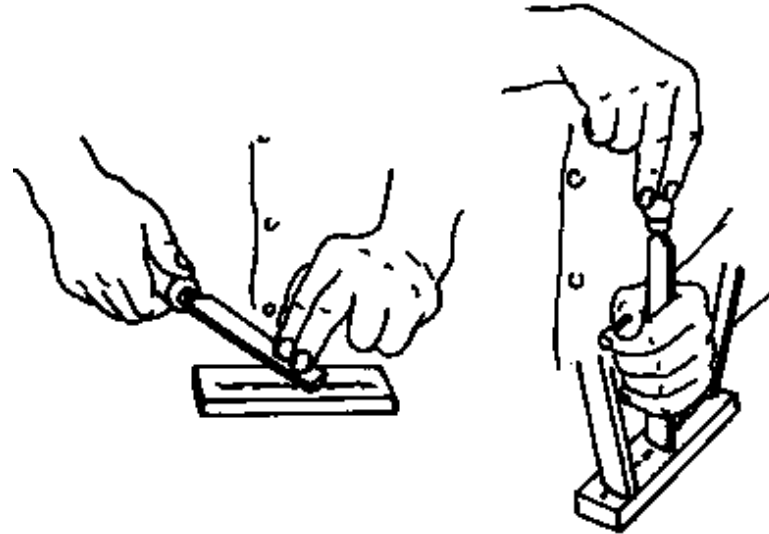

Figure 6 - Whetting of a flat scraper

What is the flat scraper used for?

What is the pulling scraper used for?

What has to be done after scraping?

What happens if one fails to carry out this last operation?



[Home](#) > [ar](#).[cn](#).[de](#).[en](#).[es](#).[fr](#).[id](#).[it](#).[ph](#).[po](#).[ru](#).[sw](#)

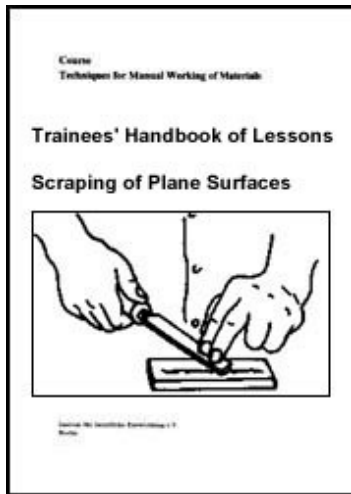

 **Scraping of plane surfaces - Course: Technique for manual working of materials. Trainees' handbook of lessons (Institut fr Berufliche Entwicklung, 14 p.)**

 **(introduction...)**

 **1. Purpose of scraping**

 **2. Tools for scraping**

 **3. Purpose of inking**

 **4. Testing and auxiliary equipment for inking**

 **5. Operation of scraping**

 **6. Technological process of planing a plane surface**

 **7. Additional recommendations**

3. Purpose of inking

Inking is the technique of testing the quality of scraped surfaces by checking them against roaster plates. With the help of roaster plates and ink, unevennesses and faults of shape are made visible on the surface of the workpiece. Inking and scraping alternate with each other. The combination of inking and scraping characterizes the actual working process and is called "planing".

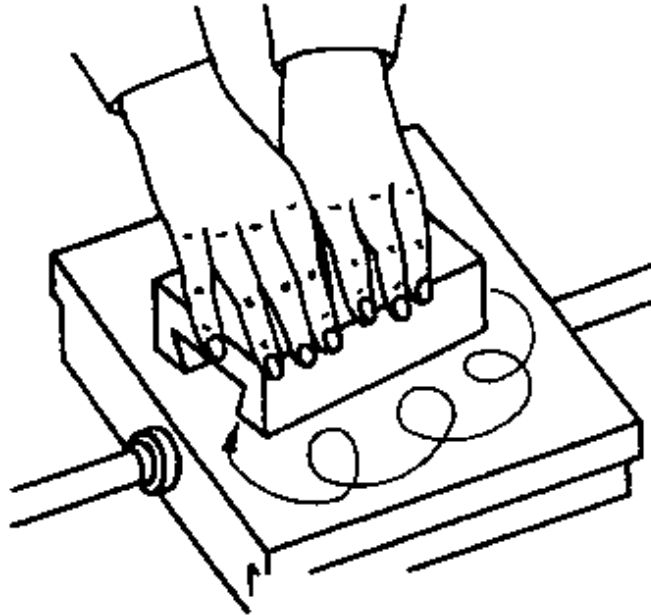
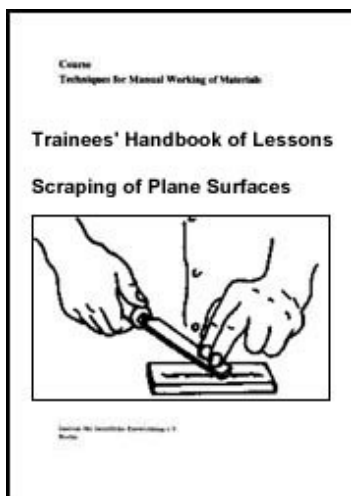

Figure 7 - Inking of a workpiece



[Home](#) > [ar](#).[cn](#).[de](#).[en](#).[es](#).[fr](#).[id](#).[it](#).[ph](#).[po](#).[ru](#).[sw](#)



 **Scraping of plane surfaces - Course: Technique for manual working of materials. Trainees' handbook of lessons (Institut fr Berufliche Entwicklung, 14 p.)**

 **(introduction...)**

 **1. Purpose of scraping**

 **2. Tools for scraping**

 **3. Purpose of inking**

 **4. Testing and auxiliary equipment for inking**

 **5. Operation of scraping**



6. Technological process of planing a plane surface

7. Additional recommendations

4. Testing and auxiliary equipment for inking

Master plates are made of wear-resistant, dense grey cast iron. The testing faces are of highest accuracy, the bottom sides mostly being equipped with stiffening ribs in order to make the roaster plate rigid and unbendable.

Surface plate

Large plate on which small to medium-size workpieces are checked; the workpiece is moved over the plate.

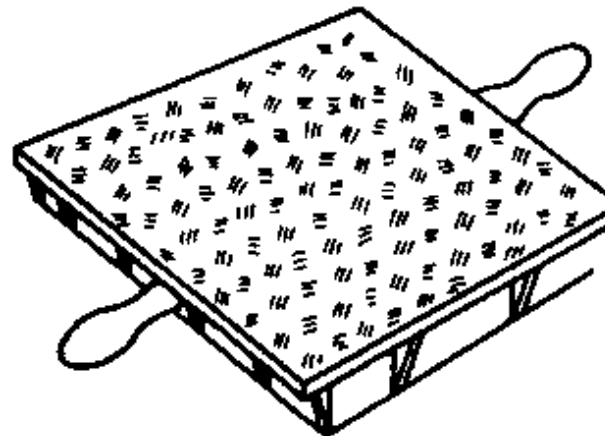

Figure 8 - Surface plate

Straight edge

Instrument for checking long and narrow workpiece surfaces, the instrument being moved over the workpiece.



Figure 9 - Straight edge

Planing bar

Instrument for checking prismatic guideways. Here, two testing faces have the same angle to which the prismatic guide shall be planed. The instrument is moved in the prismatic guide.

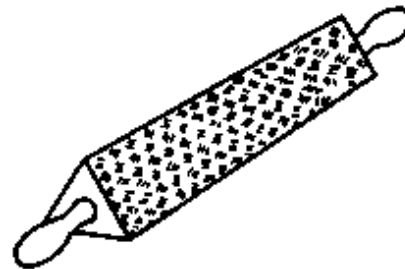

Figure 10 - Planing rod

Planing instrument for slideways

Specially shaped instrument for inking slideways of machines - the sliding faces are shaped corresponding to the machine bed. The instrument is moved over the bedways of the machine.

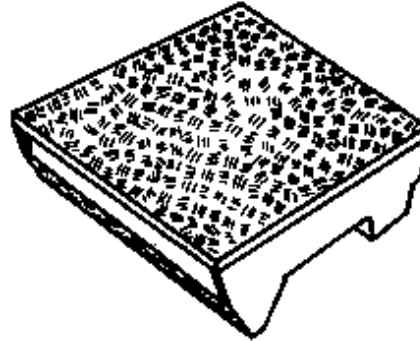

Figure 11 - Planing device for guides

Ink or inking paste:

Colouring agent for making visible the unevennesses on worked surfaces

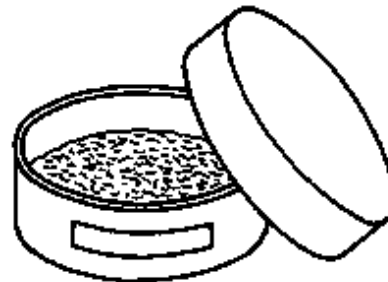
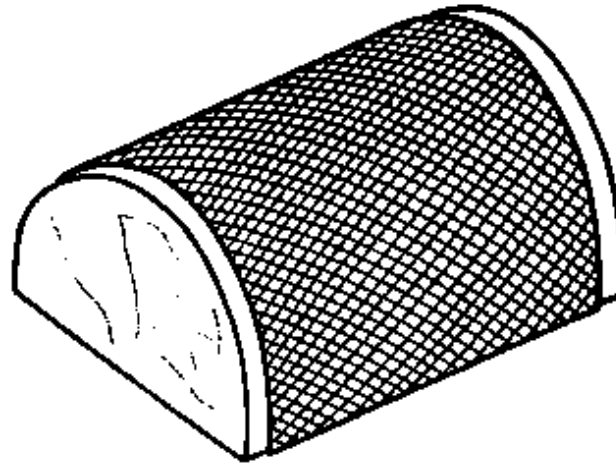

Figure 12 - Inking paste

The paste consists of pine black, clay or red-lead and oil - for use in light rooms. With unfavourable light conditions, red ink (powdered iron oxide) is used for preinking and black ink for reinking. With spot scraping, the use of blue ink (iron cyanide compound) is recommended.

Inking block

Block of wood covered by cloth that does not unweave or by leather for distributing the

ink.**Figure 13 - Inking block**

What is understood by planing a surface?

When do you use surface plates and straight edges? Explain the difference.

What is the task the ink has to fulfill?



Home > [ar](#).[cn](#).[de](#).[en](#).[es](#).[fr](#).[id](#).[it](#).[ph](#).[po](#).[ru](#).[sw](#)

 **Scraping of plane surfaces - Course: Technique for manual working**

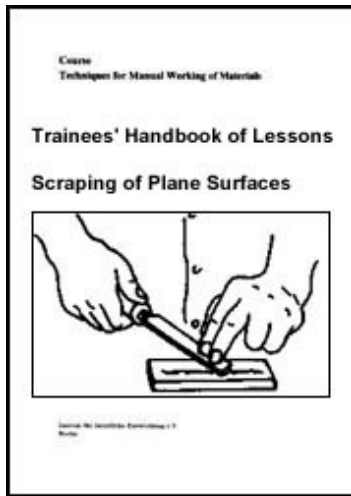

of materials. Trainees' handbook of lessons (Institut für Berufliche Entwicklung, 14 p.)

📄 **(introduction...)**

📄 **1. Purpose of scraping**

📄 **2. Tools for scraping**

📄 **3. Purpose of inking**

📄 **4. Testing and auxiliary equipment for inking**

➔ 📄 **5. Operation of scraping**

📄 **6. Technological process of planing a plane surface**

📄 **7. Additional recommendations**

5. Operation of scraping

The scraper is moved over the workpiece by the pushing or pulling power of the hand. The chips are removed not by cutting but by squeezing, because the scraper is applied to the workpiece by an angle of inclination of approximately 45° which results in a cutting angle of more than 90° .

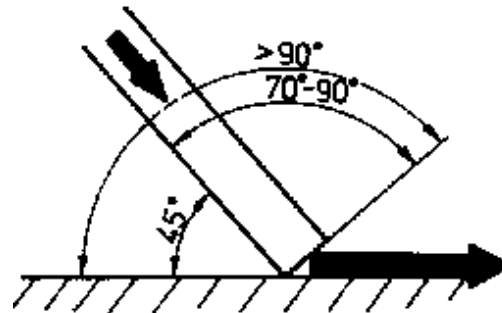
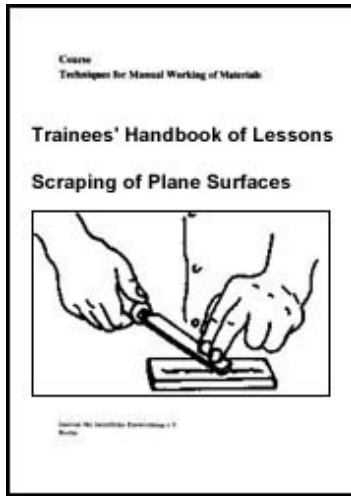

Figure 14 - Angles with push-scraping



 **Scraping of plane surfaces - Course: Technique for manual working of materials. Trainees' handbook of lessons (Institut fr Berufliche Entwicklung, 14 p.)**

 **(introduction...)**

 **1. Purpose of scraping**

 **2. Tools for scraping**

 **3. Purpose of inking**

 **4. Testing and auxiliary equipment for inking**

 **5. Operation of scraping**

 **➔ 6. Technological process of planing a plane surface**

 **7. Additional recommendations**

6. Technological process of planing a plane surface

6.1. Prescraping

By prescraping, the working traces on the rough-finished work-piece surface are eliminated and the surface is smoothed. The surface is scraped by long, strong strokes, the flat scraper has to be applied in an inclined position to the existing working traces using the sides alternately.

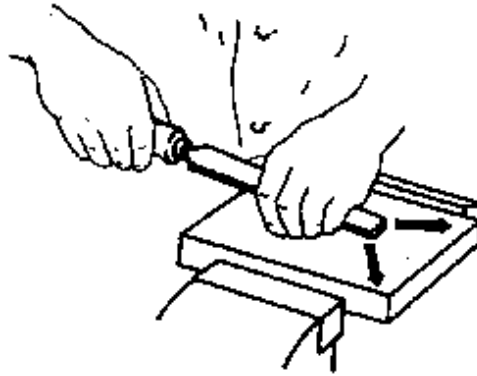

Figure 15 - Prescraping

Each scraping stroke must be carried out by increasing and decreasing manual pressure, so that no ledges occur on the surface. The scraper is drawn back without pressure in order to save the cutting edge.

6.2. Inking

By the inking block, the inking paste is spread on the inking device extremely thin and rubbed.

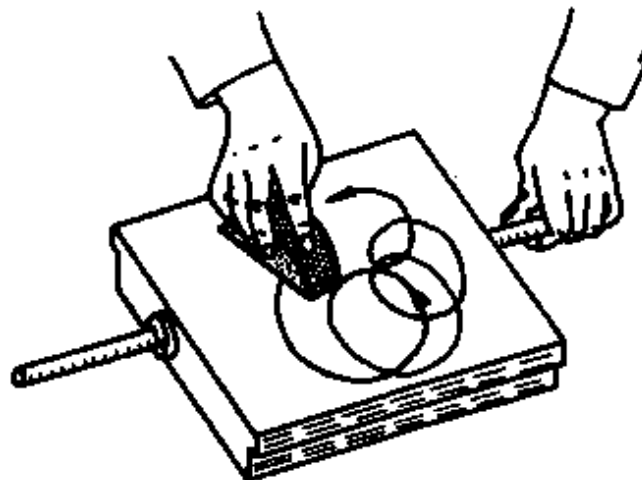

Figure 16 - Spreading of inking paste

Small workplaces are moved slowly and in circles on the inked surface plate; on large workpiece surfaces, the straight edge is drawn over the surface.

At places where surfaces get in touch with one another, ink is rubbed down, whereas in deeper places, ink is accumulated. Extremely deep spots are not touched by the ink.



Figure 17 - Surface appearance

A surface appearance is created this way:

Slightly coloured spots: highest points

Strongly coloured spots: medium position

Noncoloured spots: deepest points

6.3. Spot scraping

In order to achieve closely adjacent surfaces, the highest points (slightly coloured) are scraped with frequent change of direction and checked against a master plate until there are three times as many highest points in comparison with deepest points.

In this process, the flat scraper is pushed over the highest points in short curves.



Figure 18 - Prescraping

6.4. Finishing and pattern scraping

If the quality of spot scraping does not lead to a satisfactory result, the surface is reworked with the help of the pulling scraper which is drawn over the highest point with slight pressure by the hand.

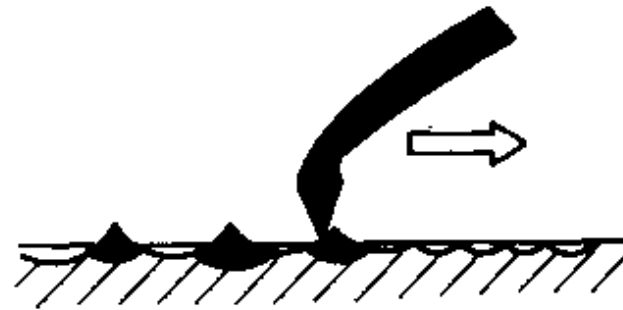

Figure 19 - Finishing

The pulling scraper may be used for making a pattern if it is drawn over the workpiece in regular movements. Common patterns are stripes and plaited patterns.

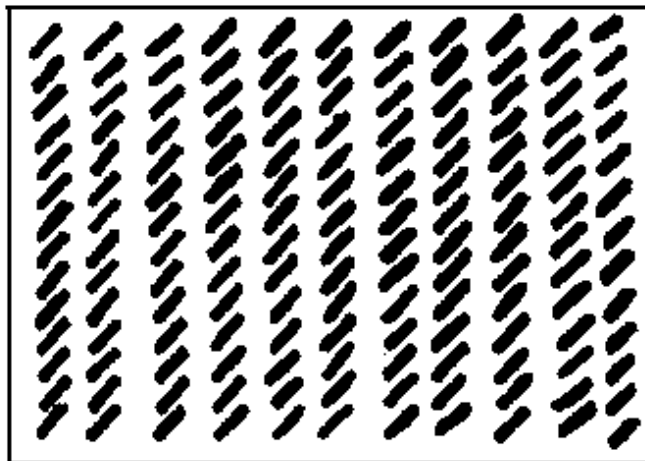

Figure 20 - Striped pattern

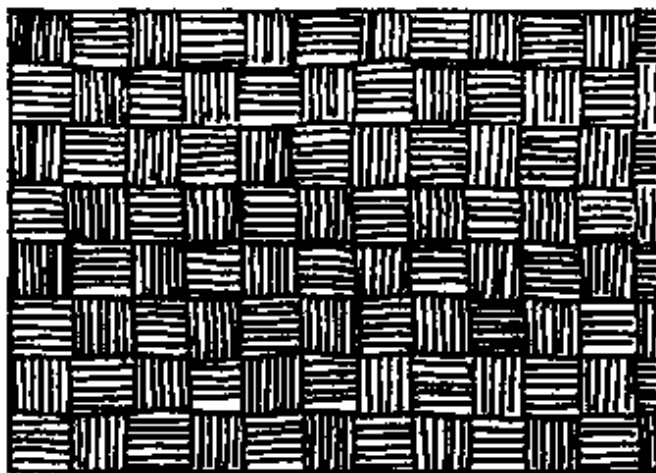

Figure 21 - Plaited pattern

Patterns are scraped if:

- **workpieces shall look better;**
- **the adherence of the greasing film shall be guaranteed with sliding surfaces;**
- **the abrasion of guiding surfaces shall be controlled (in case of wear the pattern**

disappears).

What sequence of operations characterizes the planing of a plane surface?

What characterizes the prescraping?

What characterizes the spot scraping?

What characterizes the finishing operation?



[Home](#) > [ar](#).[cn](#).[de](#).[en](#).[es](#).[fr](#).[id](#).[it](#).[ph](#).[po](#).[ru](#).[sw](#)

 **Scraping of plane surfaces - Course: Technique for manual working of materials. Trainees' handbook of lessons (Institut fr Berufliche Entwicklung, 14 p.)**

 **(introduction...)**

 **1. Purpose of scraping**

 **2. Tools for scraping**

 **3. Purpose of inking**

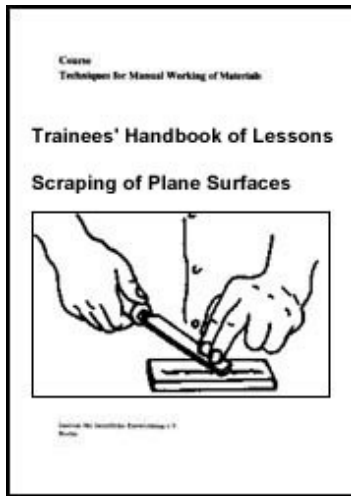

- 4. Testing and auxiliary equipment for inking
- 5. Operation of scraping
- 6. Technological process of planing a plane surface
- ➔ 7. Additional recommendations

7. Additional recommendations

- Do only use properly whetted scrapers.
- Workpieces have to be clamped that way, that they do not distort under the clamping force.
- Spread the ink extremely thin and evenly.
- Protect the surfaces of roaster plates against damages, prevent them from rusting by oiling them after use.

