

**Shaping of Horizontal and Plane Surfaces – Course: Techniques for  
Machining of Material. Trainees' Handbook of Lessons**



# Table of Contents

## **Shaping of Horizontal and Plane Surfaces – Course: Techniques for Machining of Material.**

<b><u>Trainees' Handbook of Lessons</u></b> .....	<b>1</b>
<u>1. Purpose of shaping horizontal and plane surfaces</u> .....	1
<u>2. Kinds and construction of shaping tools to be used</u> .....	2
<u>3. Preparation for shaping of horizontal and plane surfaces</u> .....	7
<u>4. Shaping of horizontal and plane surfaces</u> .....	15



# Shaping of Horizontal and Plane Surfaces – Course: Techniques for Machining of Material. Trainees' Handbook of Lessons

Institut für berufliche Entwicklung e. V.  
Berlin

Original title:  
Arbeitsmaterial für den Lernenden  
"Stoßen von waagerechten und ebenen Flächen"

Author: Detlev Krechlok

First edition © IBE

Institut für berufliche Entwicklung e.V.  
Parkstraße 23  
13187 Berlin

Order No.: 90–35–3402/2

## 1. Purpose of shaping horizontal and plane surfaces

Shaping as a cutting process with a single-edged tool is effected in the interrupted cut by utilizing the working stroke. When the tool is being returned (return stroke), no chips are removed.

Shaping is closely related to the technique of planing. The differences exist in the cutting and feed movement. In the case of shaping the tool performs the cutting movement and the workpiece performs the feed movement.

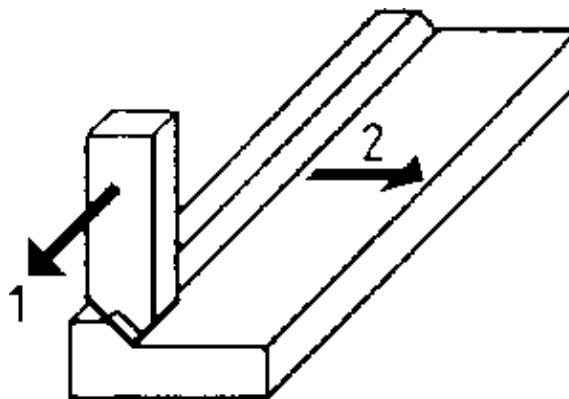

Figure 1 Working movements during shaping

1 cutting movement,  
2 feed movement

In the case of planing the tool performs the feed movement and the workpiece performs the cutting movement.

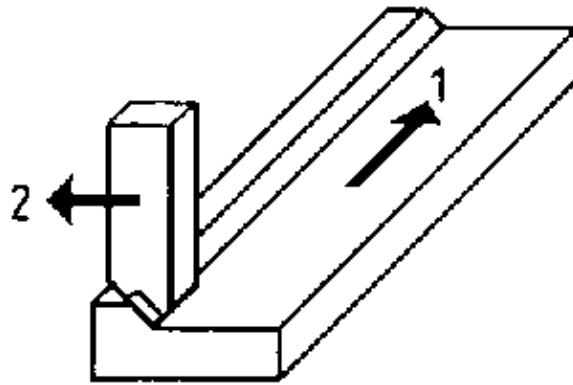

Figure 2 Working movements during planing

- 1 cutting movement,
- 2 feed movement

The technique of shaping can be performed as shaping or slotting.

During shaping normally big amounts of material are removed by straight-lined cutting and feed movements. Prefabricated prismatic and rotationally symmetrical workpieces are machined. As with shaping a maximum surface finish of  $R_z = 10 \mu\text{m}$  can be reached, subsequent techniques such as grinding and scraping are applied.

What differences exist between shaping and planing?

---



---



---

What is the purpose of shaping in the metal-working industry?

---



---



---

## 2. Kinds and construction of shaping tools to be used

Shaping tools show a great variety as far as their shapes and dimensions are concerned. Generally all tools (lathe tools) can be used which are also applied for the technique of turning. The straight tool is the most frequently used tool. It can take up great cutting forces, but it has the property to bounce and, thus, to hook into the work.

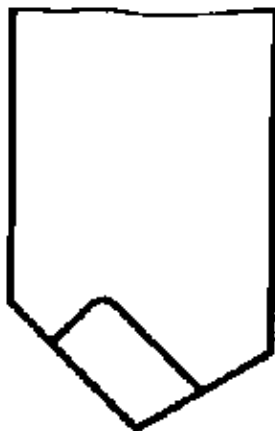

Figure 3 Straight tool

The offset tool is used, as a rule, for side machining.



Figure 4 Offset tool

The bent tool is used when machining with the straight tool is not possible. Its advantage is a quiet working position. Thanks to this a longer tool life (life between regrinds) and a better surface finish are reached.

The lateral pressing out of the cut which may occur with greater cutting force is of disadvantage.



Figure 5 Bent tool

Forward offset tools are only used, if the tool holder does not allow the use of another tool. It quickly hooks into the work and breaks.



Figure 6 Forward offset tool

Backward offset tools are especially suitable, as they bounce out of the workpiece and, thus, do not hook into it.



Figure 7 Backward offset tool

The shoulder tool is used for machining shoulders. Because of its cutting-edge shape, however, the risk of getting broken is greater on this tool.



Figure 8 Shoulder tool

Pointed or wide-finishing tools are used according to the shape of the workpiece and the surface finish,

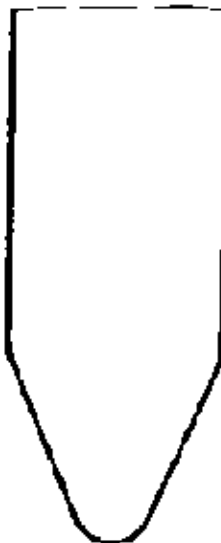

Figure 9 Pointed tool



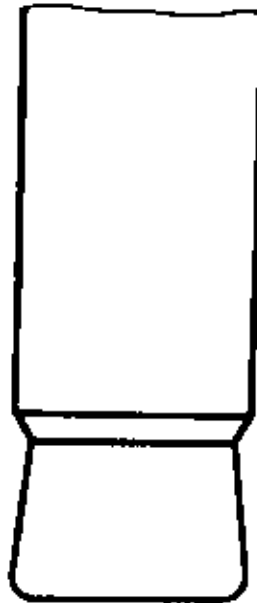

Figure 10 Wide-finishing tool

The distinguishing feature of left-hand and right-hand tools is the position of the primary cutting edge to the person holding the tool.

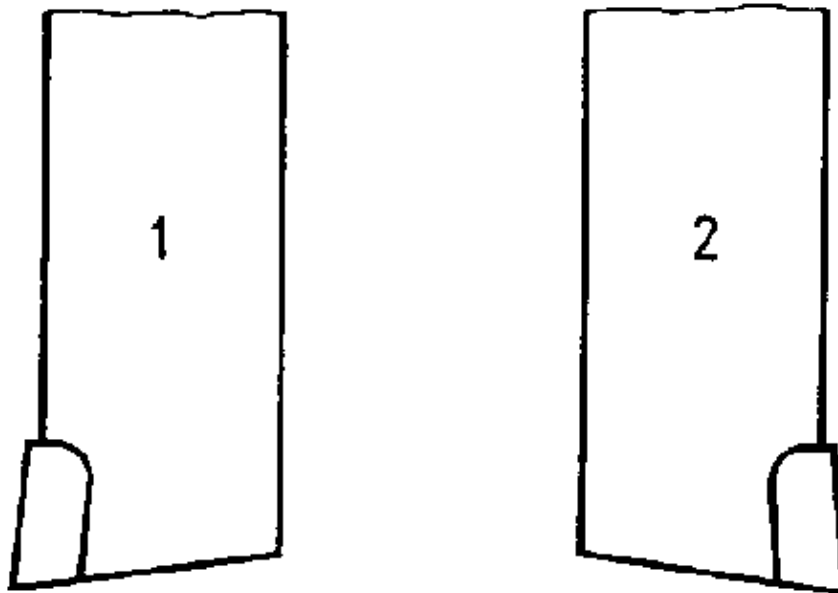

Figure 11 Position of primary cutting edge

1 left-hand tool,  
2 right-hand tool

The shaper tools can be constructed as solid or compound tools, Apart from a different shape, the basic construction does not differ considerably.

Compound tools are characterized by having tool body and tip body made of different materials.

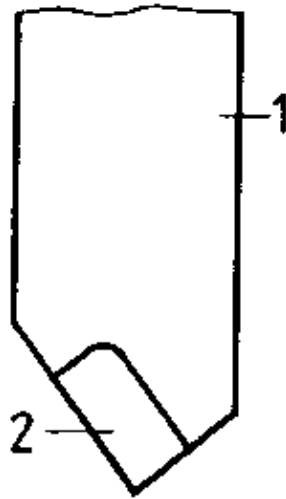

Figure 12 Compound tools

- 1 tool body (shank),
- 2 tip body

The connection between tool body and tip body can be firm (welded-on, soldered-on), but also loose (mechanically held). The mechanically held form shall be given preference due to the quick replaceability.

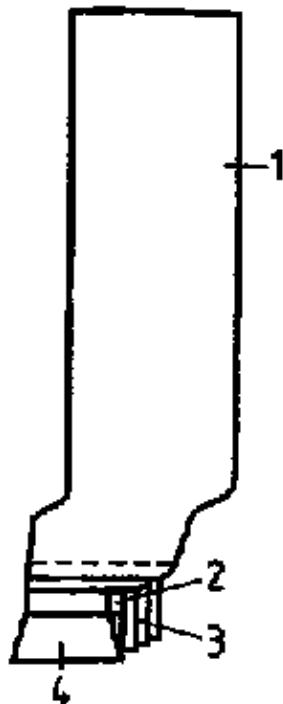

Figure 13 Mechanically held tool

- 1 shank,
- 2 clamping bolt,
- 3 holder for clamped tool bit,
- 4 clamped tool bit

Which shaper tools can be used for shaping horizontal and plane surfaces?

---



---



---

What does a compound tool consist of?

---



---



---

### 3. Preparation for shaping of horizontal and plane surfaces

Prophylactic health and fire protection and labour safety are an essential requirement for carrying out machining of material.

Therefore, the following requirements are to be met:

- Keep your workplace always clean and in order. So you will not lose any time in looking for things you need for work.
- Use only such working tools which are in an unobjectionable condition.
- According to the job use appropriate protection (safety goggles in case of flying chips, protective gloves against sharp-edged workpieces).
- For cleaning, checking and clamping place machine out of operation. Do not make safety devices ineffective.
- Use appropriate aids for chip removal (brush, broom.etc.)
- In case of defects which affect the operational reliability of the machine do not start the machine and eliminate the defect.
- During shaping great lateral compressive forces (shaping) or support pressures (slotting) often occur. Make use of the clamping equipment in such a way that the workpiece will not be permanently deformed.

Prepare the sequence of operations in such a manner that all necessary working tools and objects of work can immediately be used without losing any time.

This includes above all:

- Receive the work order and the workpieces to be machined. Check the workpieces for completeness and accuracy to size, i.e. check the premachining quality.
- Read the technical drawing (working drawing) and the work accompanying data sheets.
- Lay out and check the necessary working means (tools, measuring and testing means, clamping and auxiliary equipment) according to the work order.
- Determine the cutting values.
- Fix the sequence of operations.

#### Clamping the workpieces for shaping horizontal and plane surfaces

When machining is made on shaping machines, work-holding equipment has the following functions:

1. Positioning – fixing of the workpiece's position in relation to the tool
2. Clamping – Counteraction to the cutting forces occurring during the machining process

The clamping elements to be used must bring the workpiece into the necessary position to the tool and neutralize the cutting forces.

Therefore, each workpiece clamping must be

- firm, safe and definite in position and
- ensure the clamping reliability without resulting in permanent deformations of the workpiece.

For this reason greatest importance shall be attached to a job-related, firm workpiece clamping according to labour safety.

The choice of the respective clamping equipment depends on

- the shape, size and number of workpieces to be machined
- the cutting values to be applied
- the workpiece position, its direction and quality.

Proper use of the clamping equipment requires to know exactly what cutting forces occur.

In case of shaping the cutting force acts parallel to the workpiece support and in the case of slotting it acts vertically to the workpiece support.

The following main clamping equipment is used:

#### Machine vices

for chucking small workpieces with parallel bearing surfaces (most frequently used kind of clamping workpieces). Positioning of the machine vice is made by means of tongues.

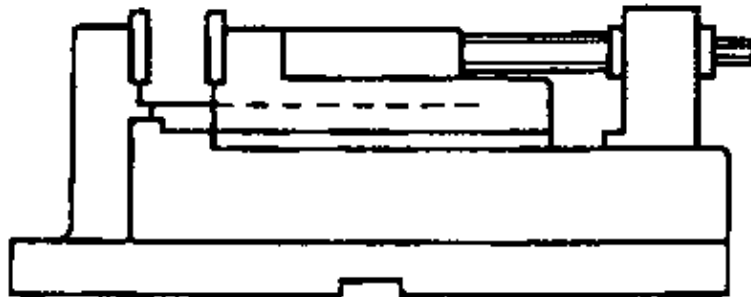

Figure 14 Machine vice

Clamping bolts for mounting further clamping equipment or workpieces with bore holes.



Figure 15 Work-holding bolt

#### Clamps

for clamping large workpieces on the machine table or thin-walled workpieces which would bend in the machine vice.

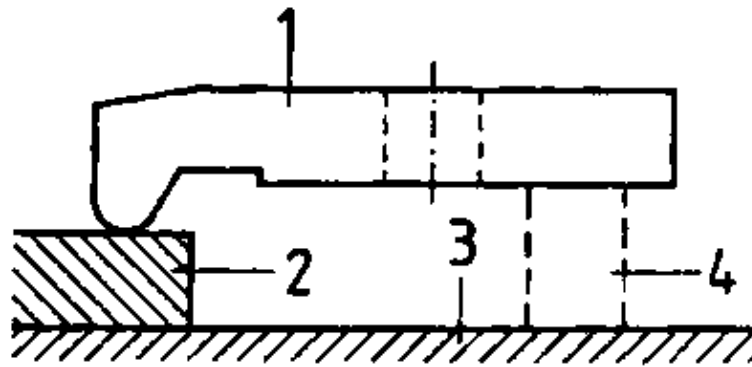

Figure 16 Clamp in use

- 1 clamp,
- 2 workpiece,
- 3 worktable,
- 4 base

### Clamping dies

for clamping workpieces which cannot be set up by means of clamps by making use of the wedge effect,

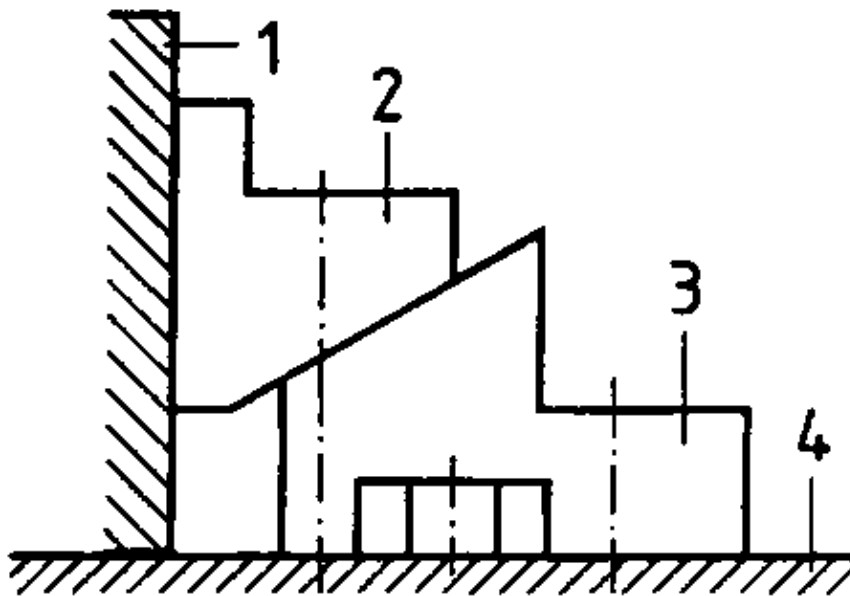

Figure 17 Clamping dies in use

- 1 workpiece,
- 2 fixed clamping die,
- 3 movable clamping die,
- 4 work-clamping area

### Angle-plates

as rotatable or tiltable clamping equipment with the help of T-slot bolts.

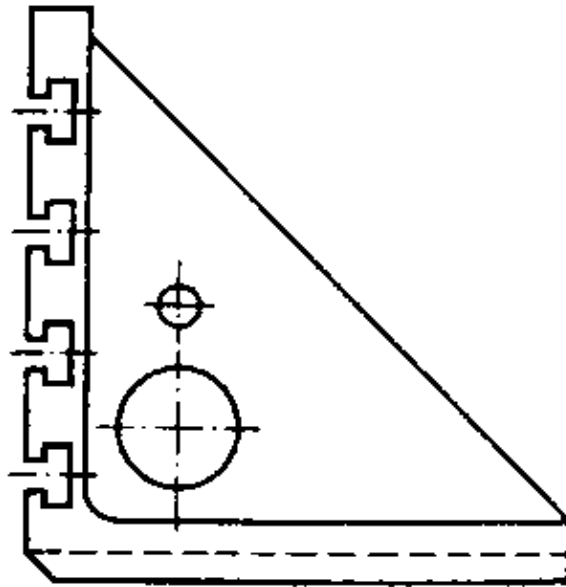

Figure 18 Angle-plate

### Electromagnetic chucks

for chucking workpieces which are machined with small cutting forces (finish machining and fine finishing).

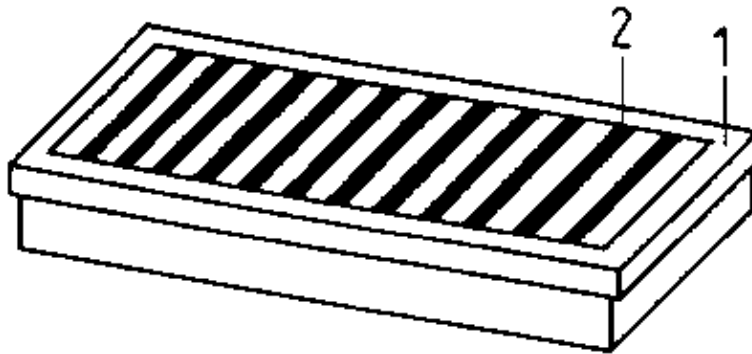

Figure 19 Electromagnetic chuck

1 plate,  
2 pole strips

### Clamping supports

for height adjustment when clamps are used.

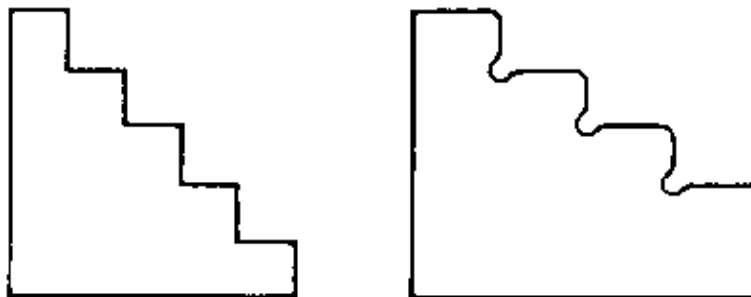

Figure 20 Clamping supports

### Fixtures

They are used for holding workpieces which due to their geometrical shape cannot or only with considerable effort be clamped with usual clamping equipment such as vice, stop and clamps.

This is the safest kind of clamping ensuring high quality which, however, is dependent on the specific workpiece and construction of the fixture.

In addition to this, we distinguish between

- clamping the workpiece on the machine table under compression, where the workpiece is clamped from both sides by means of clamps;

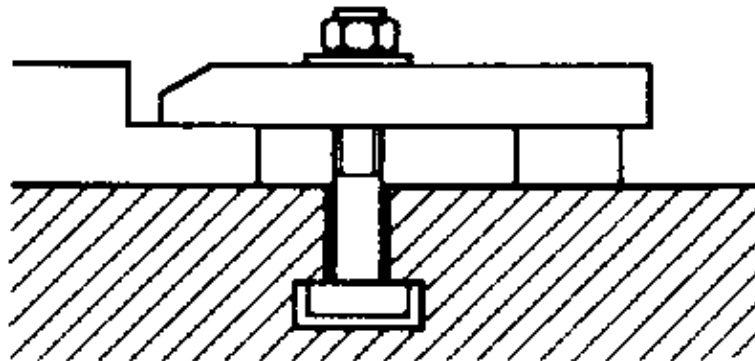

Figure 21 Clamping the workpiece on the machine table under compression

- clamping the workpiece on the machine table, this being reached by lateral clamping forces.

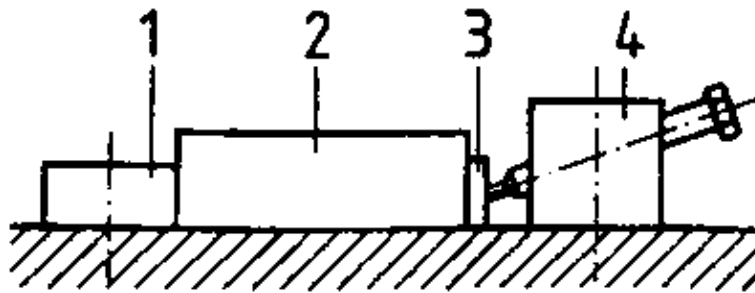

Figure 22 Clamping the workpiece on the machine table

- 1 stop,
- 2 workpiece,
- 3 work-supporting block,
- 4 clamping piece with clamping nut

Summarizing, when clamping workpieces, take care to ensure that

- an exact positioning of the workpieces to the primary motion is reached (adjust clamping equipment or workpieces)
- parallel-ground bases are used
- clamps are resting horizontally
- those points on the workpiece which are sensitive to distortion are protected (bases, wedges,.etc.)
- the clamping elements are located as close to the workpiece as possible and are arranged in such a manner that the cutting forces act against the fixed stops
- impurities between locating and supporting surfaces are removed
- clamping forces act against fixed back rests (stops, supports),

#### Clamping of tools for shaping of horizontal and plane surfaces

As tool clamping device the tool holder is used which in the case of shaping is also called tool post. In contrast

to shaping the tool is not lifted during the return stroke in the case of slotting. The tool is fixed by means of clamping bolts,

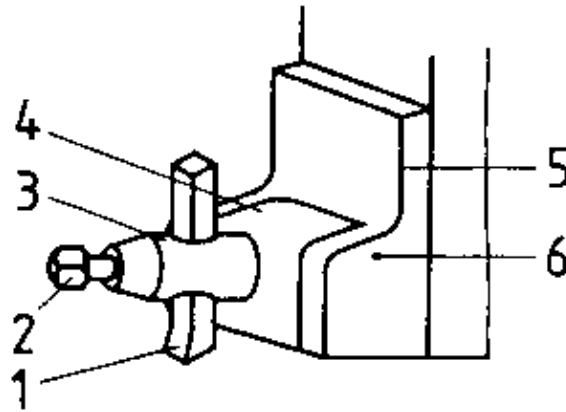

Figure 23 Tool holder

- 1 tool,
- 2 clamping bolt,
- 3 tool post,
- 4 clapper.
- 5 clapper box,
- 6 fulcrum pin

Make sure that the tool is always clamped firmly and short to keep the leverage as small as possible.

When clamping the tool, make sure that

- the tool inserted is stable enough to compensate the cutting forces occurring
- the tool is clamped as short as possible to prevent bouncing or twisting phenomena
- the clamping surfaces are free from burrs and impurities
- point-like clamping forces in hard tool material (super high-speed steel and high-speed steel) are distributed to larger surfaces by means of supports.

What is the fundamental function of work-holding equipment?

---

---

---

Mention three important clamping devices for carrying out the technique of shaping.

---

---

---

What are the advantages and disadvantages of using fixtures?

---

---

---

### Choice of cutting values

When determining the cutting values, pay attention to the following hints:

- As a rule, the shaper or slotting tools consist of high-speed steel (HSS) or super high-speed steel (SHSS) or they are compound tools with carbide tipping. as the impact load during starting of the cut does not allow the use of other superhard cutting materials.



- High-speed steel cutting materials are more break-proof than those made of hard metal, however, they do not allow high cutting speeds.
- When steel is machined with carbide-tipped shaper or slotting tools, the necessary high cutting speeds are often not reached for reasons resulting from the machine. Thus, built-up cutting edges and a considerably higher load of the tool cutting edge occur. Lower cutting speeds with the use of high-speed steel prove to be more favourable in this case.
- The grind of the tool is of decisive influence on the quality of machining and the life of the tool. The angle of inclination of the cutting edge, which due to the favourable chip disposal is chosen to be mostly negative, is of special influence,

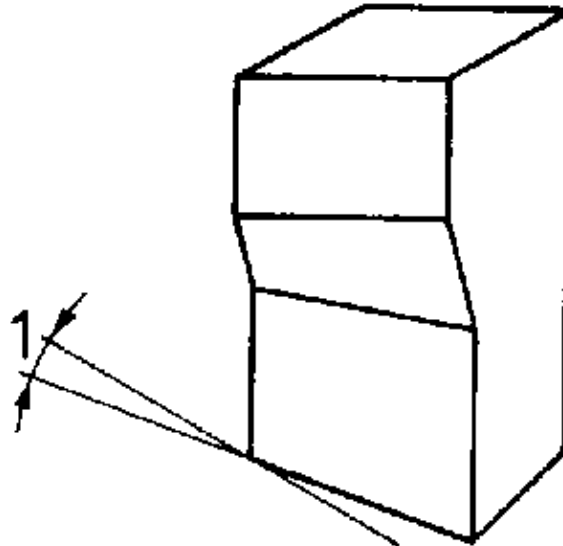

Figure 24 Shaper tool

λ angle of inclination at shaper tool

- The cutting power is influenced by the driving force of the machine and the cutting speed chosen.

In the following machining recommendations for  $v$  (cutting speed) are given:

HSS	– high-speed steel	20 – 25 m min. <sup>-1</sup>
SHSS	– super high-speed steel	26 – 35 m min. <sup>-1</sup>
HS	– hard metal	36 – 40 m min. <sup>-1</sup>

Note:

$$V_m = v \cdot \frac{1}{2}$$

The cutting power ( $P_s$ ) is calculated as follows:

$$P_s = \frac{F_s \cdot v}{60 \cdot 1000} \quad (\text{kW})$$

where

$F_s$  = cutting force (N)  
 $v$  = cutting speed (m min.<sup>-1</sup>)

A comparison between the cutting power and the drive power ( $P_A$ ) tells us, whether the machine to be used will cope with the cutting forces occurring or not,  $P$  must always be greater than  $P_s$ .

$P_A$  is calculated from

$$P_A = P_s/n \text{ (kW)}$$

$n$  = efficiency

0.7 can always be taken as efficiency ( $n$ ).

As the cutting force ( $F_s$ ) will often not be available, we can substitute for  $F_s$ :

$$F_s = k_s \cdot a \cdot s \text{ (N)}$$

where

$k_s$  = specific cutting force (N mm<sup>-2</sup>)

$a$  = cutting depth (mm)

$s$  = feed (mm)

The values for  $k_s$  can be taken from the simplified survey.

Survey 1: Specific cutting values ( $k_s$ -values)

(Values taken from turning. Multiplication factor of 1.2 is already applied),

Material	Feed s in mm									
	0.06	0.1	0.2	0.4	0.6	0.8	1.0	1.6	2.0	2.5
St 36	3384	3120	2772	2508	2304	2232	2142	1980	1908	1836
St 60	3600	3342	2952	2628	2448	2328	2232	2076	2028	1932
C 15	3948	3552	3048	2629	2376	2244	2142	1932	1836	1752
C 60	3989	3600	3180	2808	2568	2472	2352	2160	2088	2016
16 MnCr 5	4884	4332	3600	3000	2640	2496	2352	2076	1956	1836
cast iron	2760	2400	1920	1740	1464	1368	1320	1140	1080	960
brass	1548	1140	1272	1096	1028	972	936	876	828	792

Choose on your own the cutting depth ( $a$ ) and the feed ( $s$ ) according to the surface finish. Take  $v$  from the machining recommendations.

From this results

$$P_s = \frac{k_s \cdot a \cdot s \cdot v}{60 \cdot 1000} \text{ (kW)} \quad \text{and} \quad P_A = \frac{P_s}{n} \text{ (kW)}$$

and from the comparison of both ( $P_s$ ,  $P_A$ ) the degree of suitability of the machine results. Note that for determining further  $k_s$ -values these are mostly assigned to the technique of turning and must be multiplied by the factor 1.2 for shaping.

Which tool materials are used for shaping and why are harder materials excluded?

---



---

---

Which grind angle is of special influence on tool life and chip disposal?

---

---

---

Which recommended value for machining is chosen when super high-speed steel (SHSS) is used?

---

---

---

An end face on a workpiece made of St 60 with a length of 120 mm shall be machined by shaping. For machining a super high-speed steel tool is used.

Determine  $n$  (number of double strokes), if  $v_m$  is  $8,75 \text{ m min.}^{-1}$

Given:

Wanted:

Solution:

$n =$

When determining the return stroke, choose the return speed to be as high as possible (time-saving). Take into consideration the accelerating and braking forces of the table or ram in case of small strokes.

Choice and application of measuring and testing means as well as coolants and lubricants

The following measuring and testing means are used:

- flexible steel rule
- vernier caliper
- external micrometer
- dial gauge
- slip gauges
- spirit level
- protractor.

The use of necessary coolants and lubricants as well as other auxiliary equipment and utilities (brushes, compressed air, etc.) shall also be taken into account.

Liquid coolant is relatively seldom used with shaping, as the tool is not permanently engaged. If coolant is used none the less, the tool life (mainly when high-speed steel is used or long cuts are made) and the surface finish of the workpiece are increased.

Suitable coolants and lubricants are the following:

- drilling emulsion (emulsion of water and oil)
- cutting oil (for specially high surface quality)

In most cases the use of coolants and lubricants is not necessary, as the interrupted cut with sufficient chip removal prevents generation of much heat.

#### **4. Shaping of horizontal and plane surfaces**

Shaping of horizontal and plane surfaces can be classified into:

- shaping of plane surfaces

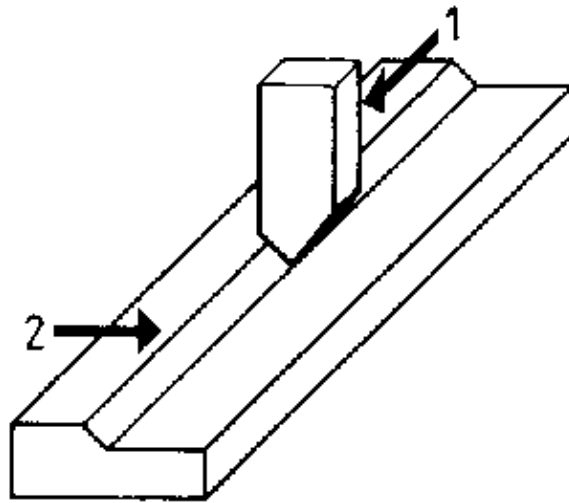

Figure 25 Shaping of plane surfaces

1 cutting movement,  
2 feed movement

– shaping of end faces

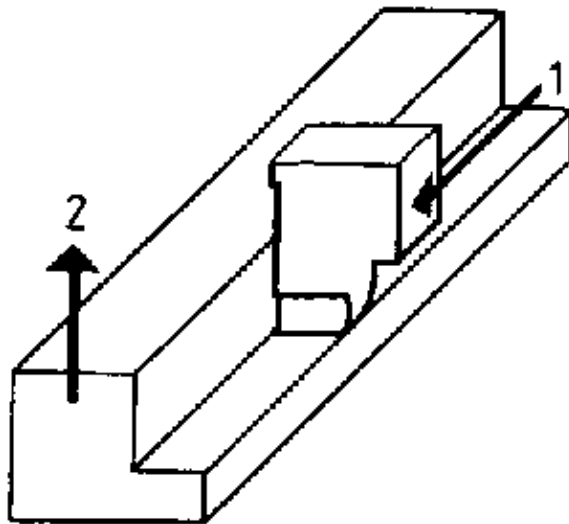

Figure 26 Shaping of end faces

1 cutting movement,  
2 feed movement

– shaping of parallel surfaces

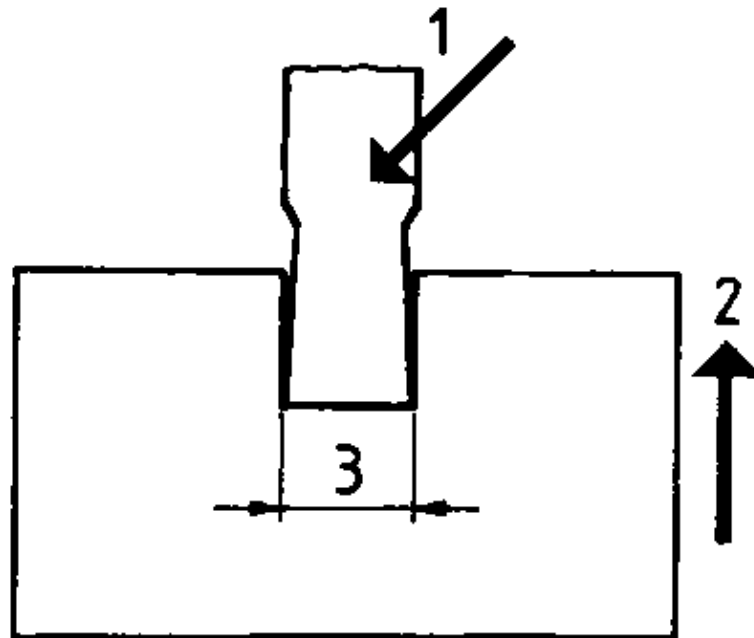

Figure 27 Shaping of parallel surfaces

- 1 cutting movement,
- 2 feed movement,
- 3 parallel surfaces

Plane surfaces are flat surfaces laying in parallel to the cutting and feed movement. They are mainly machined as reference or locating surface for subsequent operations. The clamping, locating and machining surface of the workpieces often is still unmachined.

When shaping plane surfaces, make sure that

- forged workpieces (steel) are machined with SHSS tools and workpieces made of cast iron are machined with cemented carbide tools
- workpieces sensitive to distortion are unclamped (i.e. released and clamped again) before finishing in order to avoid elastic deformations (dimensional changes after unclamping due to distortion)
- the tool point acts below the hard cast-iron or forged edges,

End faces are flat rectangular limiting surfaces on workpieces. They are created when shaping is made vertically to the plane surface.

When shaping end faces, make sure that

- the position of the horizontal reference surface is checked (adjust the workpiece, check by following the outline with the dial gauge before cutting and with the vernier caliper after the first cut).
- the lower end faces are lying free to avoid damage to the table.
- the tool slide is set vertically.
- the cutting edges of the tool are always sharp.
- the tool is clamped sufficiently long according to the cutting height.
- the clapper-type tool block is adjusted so that an inclined position from bottom left to top right results. The tool must lift itself from the surface to be machined during the return stroke.

- the recommended values for machining are reduced by approximately 50 % compared with face–shaping, as the force and movement directions are less favourable.

Parallel surfaces are surfaces of equal shape which are equally spaced to each other. They occur most frequently as plane and end faces on workpieces. Shaping of parallel surfaces is characterized by machining several surfaces lying parallel to each other, with the position of the workpiece remaining the same. This is possible, because the direction of the primary motion is not changed by the ram guide.

Parallel surfaces should be machined in such a way that re–clamping of the workpieces does not become necessary, if possible. If nevertheless reclamping of the workpieces is necessary, the parallelism to be reached is determined by the exact position of the surface machined first.

The proper use of the clamping equipment and, in connection with this, the choice and application of the elements for securing of position (stops, tongues, parallel strips, etc.) are of decisive importance for a manufacture meeting the quality standards.

When shaping parallel surfaces, always make sure that

- the surfaces machined first are used as bearing or supporting surfaces
- in each case one and the same parallel strips (base by several parallel strips) are used
- adjustment of a surface already machined is made by checking with appropriate means (e.g. dial gauge)
- checking of parallelism is made in the clamped state, if possible.

Shaping of parallel workpiece surfaces can also be made in connection with shaping of shouldered workpiece surfaces.

#### Sequence of operations 'during shaping

- Preparation of table and tool carrier for the clamping process (suitable positioning, freedom of motion)
- Clamping the workpieces and alignment to the tool
- Clamping of tool
- Scratching of workpiece
- Feeding, setting of cutting values
- Sample cutting (approx. 2 to 3 double strokes)
- Preliminary check
- Finish shaping (roughing or finishing)
- Final check

Feeding should be made when machine is at rest. For determining the length of stroke and cutting speed (number of double strokes) the following shall be applied:

$$\text{length of stroke } L = l + l_a + l_o \text{ (mm)}$$

where

(l = workpiece length,  
 $l_a$  = approach,  
 l = overrun)

number of double strokes

$$n = \frac{v_m \cdot 1000}{2 \cdot L} \quad (\text{min.}^{-1})$$

Note that the machining recommendations must be halved when determining  $v_m$ .

What surfaces are machined by the technique of shaping horizontal and plane surfaces?

---

---

---

What are the fundamental working steps of machining by means of shaping?

---

---

---

