

**Thread Cutting by Dies and Taps – Course: Techniques for Machining of Material – Instruction Examples for Practical Vocational Training.**



# Table of Contents

<b><u>Thread Cutting by Dies and Taps – Course: Techniques for Machining of Material – Instruction Examples for Practical Vocational Training</u></b> .....	<b>1</b>
<u>Introduction</u> .....	1
<u>Instruction example 5.1. Spring bolt</u> .....	1
<u>Instruction example 5.2. Ball handle</u> .....	5
<u>Instruction example 5.3. Lance</u> .....	9
<u>Instruction example 5.4. Piston</u> .....	12



# Thread Cutting by Dies and Taps – Course: Techniques for Machining of Material – Instruction Examples for Practical Vocational Training.

Institut für berufliche Entwicklung e.V.  
Berlin

Original title:  
Lehrbeispiele für die berufspraktische Ausbildung  
“Gewindeschneiden mit Schneideisen und Gewindebohrer”

Author: Horst Köth

First edition © IBE

Institut für berufliche Entwicklung e.V.  
Parkstraße 23  
13187 Berlin

Order No.: 90–33–3205/2

## Introduction

This material presents four selected instruction examples for applying and consolidating knowledge and skills in “thread cutting by dies and taps”.

The necessary materials, tools, measuring and checking means, and accessories have been indicated for each instruction example to ease preliminary work and execution. In instruction example one the steel has been designated in “megapascal” (MPa) units.

Furthermore, basic knowledge which is required in addition to facts about “thread cutting by dies and taps” is set out. We recommend that all basic knowledge is repeated prior to commencing operations.

The respective work sequences feature all steps required to turn out a certain workpiece. Adhere to this sequence in order to attain good quality.

Each instruction example has attached a workshop drawing from which the desired shapes and dimensions of the workpiece can be determined. The following table shows dimensional deviations where no tolerances are involved:

Nominal dimension	Permissible deviation in mm
0.5 – 6	± 0.1
6 – 30	± 0.2
30 – 120	± 0.3
120 – 315	± 0.5

## Instruction example 5.1. Spring bolt

This example focuses attention on thread cutting by dies on simple cylindrical workpieces.

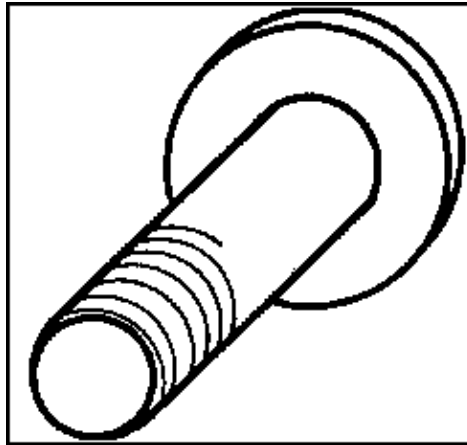

Material

stand. 42 (steel with a tensile strength of up to 420 MPa)

Dimensions

Ø 38 x 96

Tools

recessed right-side cutting turning tool, die M 20, chucking spanner

Measuring and testing tools

vernier caliper, thread ring gauge M 20

Accessories

extendable chucking jaws, rotating tip, log measure 45 mm, coolants and cutting compounds

Required previous knowledge

drawing comprehension, measuring and testing, thread cutting by hand, longitudinal turning and surfacing, possibilities and employment of chucking and accessories

Workshop drawing explanations

M 20: M = metric thread      All surfaces have been machine-finished.  
 20 = nominal diameter

**Sequence of operations**      **Remarks**

1. Dimensional inspection

2. Clamp workpiece      Clamping in extendable jaws to Ø 36 mm

3. Clamp tool

4. Set the cutting values for longitudinal turning

5. Yield thread  $\varnothing$  M 20      Clamping – rotational tip in diameter 20 mm x 45 mm to 19.8 mm as, whilst cutting, the external diameter increases by about 1/10 of the thread increment amount.  
Deburring of the workpiece 2.5 mm x 45°!
6. Set the cutting values for thread cutting      For steel  $v = 3 - 4 \text{ m min}^{-1}$
7. Position die      Straight positioning by pressing down the quill
8. Cut the thread      It is sensible to cut a few turns by hand whilst the machine is switched off.  
Ensure proper cooling and lubrication.  
Keep the chip chambers clean.  
Ensure that the tool frame of the die holder is supported.  
Prior to machine reverse also turn back several times by hand.
9. Unload the workpiece
10. Dimensional inspection

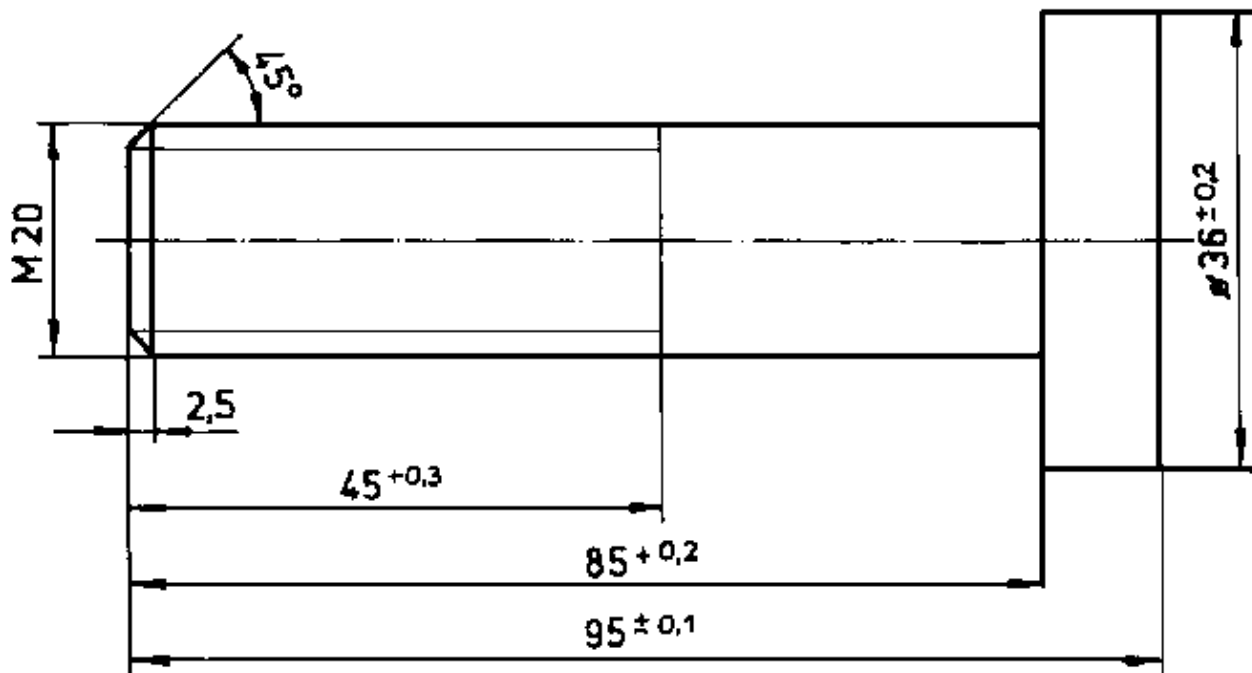
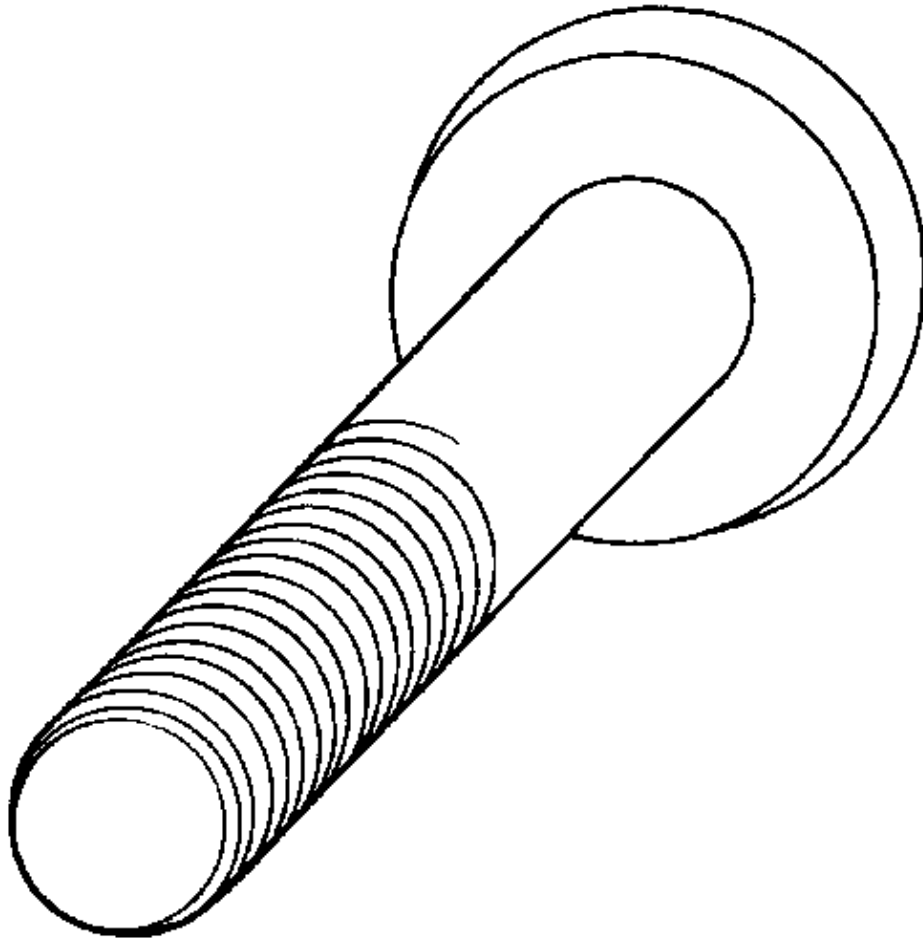

			5.1.
	Spring bolt		3205



## Instruction example 5.2. Ball handle

In this example thread cutting by dies on recessed cylindrical workpieces is practised.

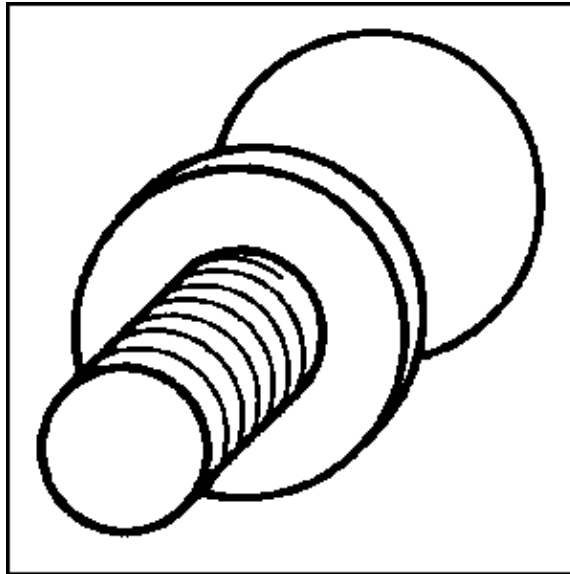

### Material

16 Mn Cr 5 (low-alloyed steel, alloy components: 0.16 % carbon, 1.25 % manganese, less than 1 % chrome, rest iron)

### Dimensions

Ø 42 x 87

### Tools

offset right-hand cutting turning tool, die M 24, clamping spanner

### Measuring and testing tools

vernier caliper, thread ring gauge M 24

### Accessories

extendable chucking jaws, coolants and lubricants

### Required previous knowledge

drawing comprehension, measuring and checking, thread cutting by hand, longitudinal turning and surfacing

### Workshop drawing explanations

M 24: M= metric thread                      All surfaces have been machine-finished.  
24 = nominal diameter

**Sequence of operations**                      **Remarks**

1. Dimensional inspection
2. Clamp workpiece                      Clamping in extendable jaws to  $\varnothing$  40 mm (collar)
3. Clamp tool
4. Set the cutting values for longitudinal turning
5. Yield thread  $\varnothing$  M 24                      Clamping in extendable chucking jaws.  
Diameter 24 x 30 mm to 23.7 x 30 mm as, whilst cutting, the external diameter increases by about 1/10 of the thread increment amount.  
Deburring of the workpiece.
6. Set the cutting values for thread cutting                      For steel  $v = 3 - 4 \text{ m min}^{-1}$ .
7. Position die                                      Straight positioning by pressing down the quill
8. Cut the thread                                      It is sensible to cut a few turns by hand whilst the machine is switched off.  
Ensure proper cooling and lubrication.  
Keep the chip chambers clean. Switch off the machine about 2 – 3 mm before attaining the collar  $\varnothing$  40 mm and cut the last turns by hand.
9. Unload the workpiece
10. Dimensional inspection



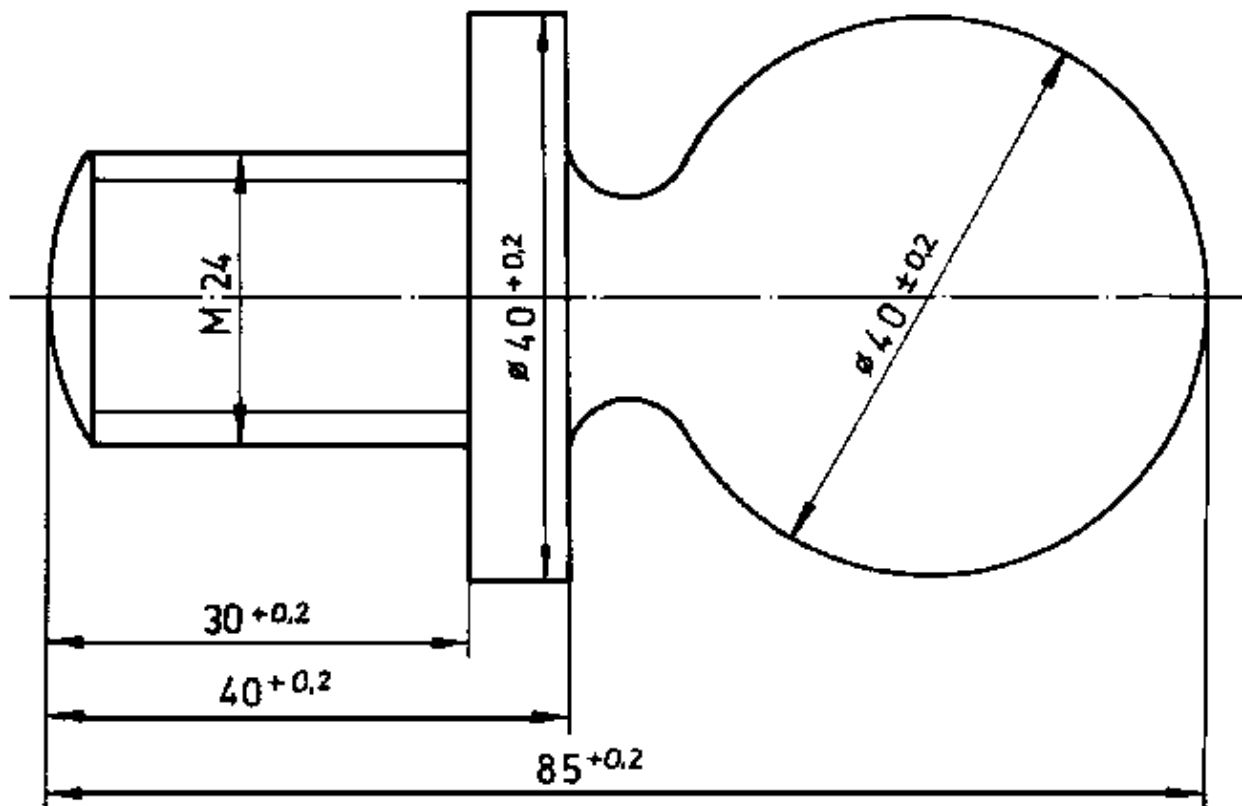
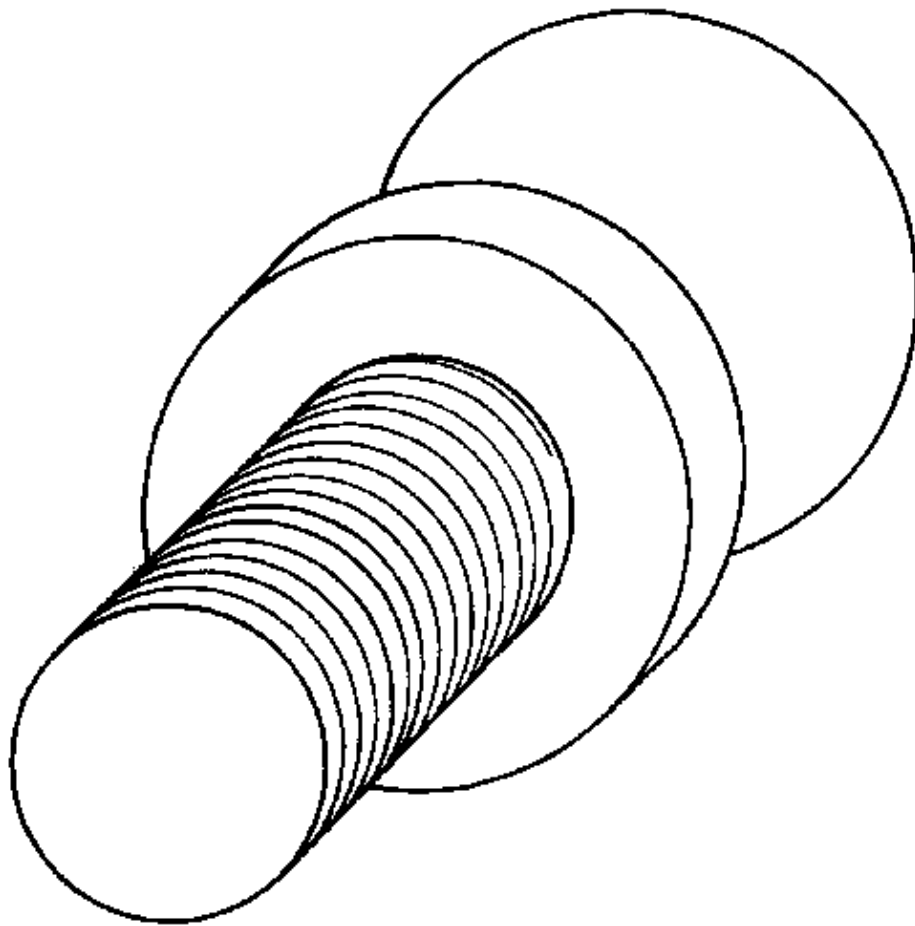

			5.2.
		Ball handle	3205 <sup>8</sup>

### Instruction example 5.3. Lance

In this example particular attention is given to practising thread cutting by tap on through holes.

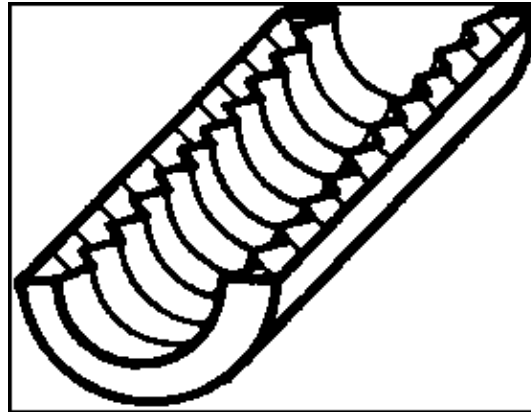

#### Material

35 Cr Al 6 (low-alloyed steel, alloy components: 0.35 % carbon, 1.5 % chrome, 1 % aluminium, rest iron)

#### Dimensions

Ø 52 x 87

#### Tools

bent right internal roughing lathe, clamping spanner, one set of hand taps M 30

#### Measuring and testing tools

internal thread gauge M 30, vernier caliper

#### Accessories

extendable chucking jaws, tap wrench, coolants and lubricants

#### Required previous knowledge

drawing comprehension, measuring and checking, thread cutting by hand, centring, boring, counter-boring

#### Workshop drawing explanations

M 30: M = metric thread      All surfaces have been machine-finished.  
30 = nominal diameter

#### **Sequence of operations**

#### **Remarks**

1. Dimensional inspection

2. Clamp workpiece

Clamping in extendable chucking jaws. Ensure true running.

3. Clamp tool Use prismatic base as lathe has a round shank.
4. Set the cutting values for boring
5. Yield thread  $\varnothing$  M 30 Bore to  $\varnothing$  26.7. Material is compressed during thread cutting resulting in a bore diameter decrease. Debur 2 mm x 45°!
6. Set the cutting values for thread cutting For steel  $v = 4 - 15 \text{ m min}^{-1}$  according to material and thread size
7. Position tap Select manual tap. Position the railstock tip to centring of tap.
8. Cut the tap Sequence – entering tap, plug tap thread, plug (third) tap.  
Initially use the plug tap and plug (third) tap to undertake several turns by hand so that the tap sets to the prenotched thread.  
Ensure tap wrench support.  
Keep the chip grooves clean by turning back the tap several times.  
Ensure proper cooling and lubrication. Indicate possible accident hazards 1
9. Unload the workpiece
10. Dimensional inspection

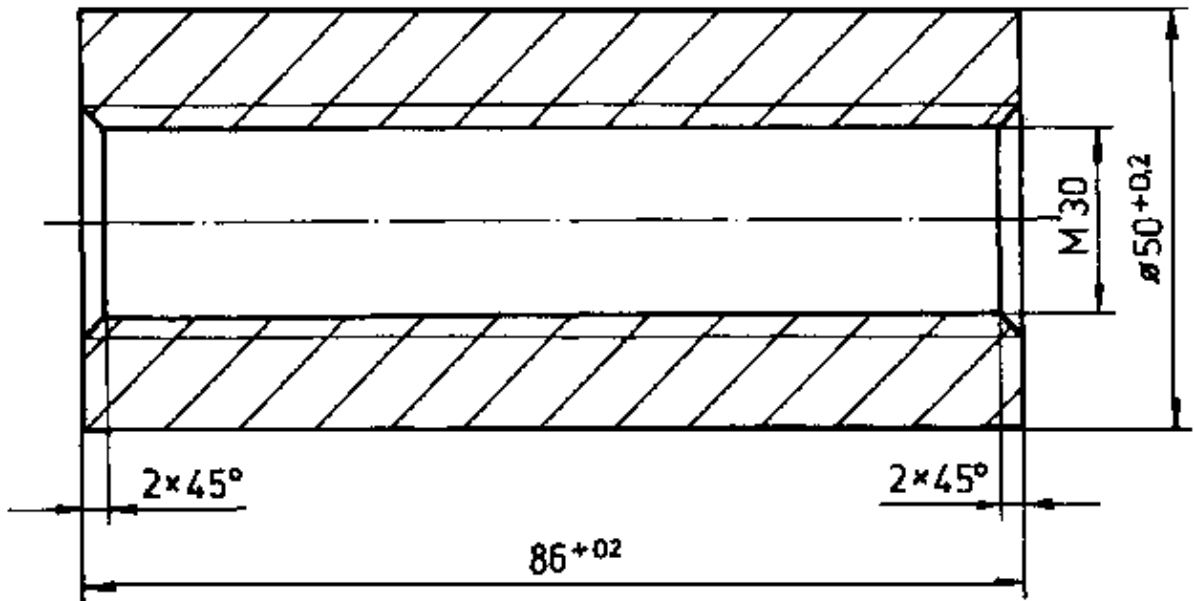
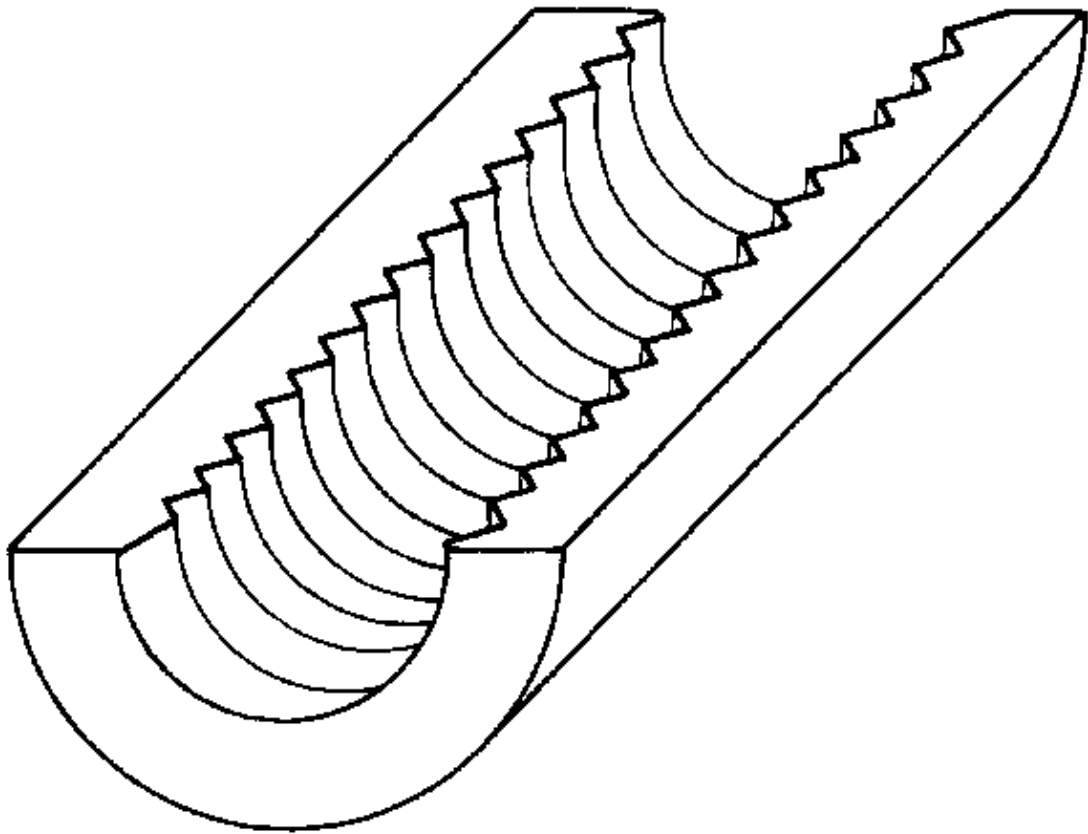

			5.3.
		Lance	3205

Lance

## Instruction example 5.4. Piston

In this example thread cutting is undertaken in blind holes by means of taps.

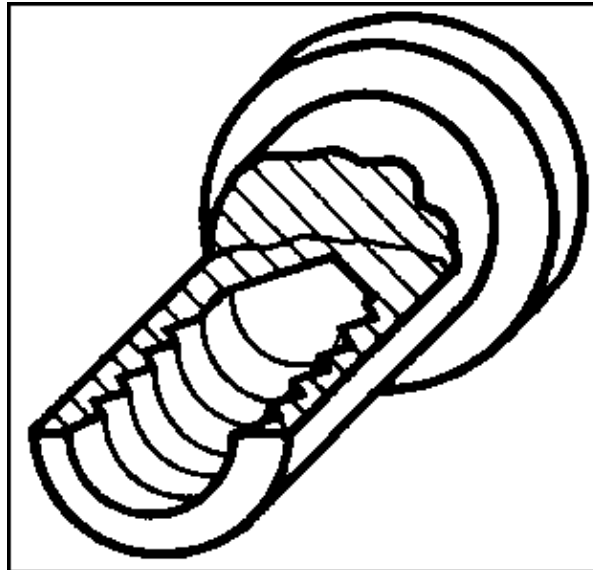

### Material

16 Cr Mo 4 (low-alloyed steel), alloy components: 0.16 % carbon, 1 % chrome, less than 1 % molybdenum, rest iron.

### Dimensions

Ø 45 x 93

### Tools

spiral drill Ø 17.5 mm, machine tap M 20, chucking spanner

### Measuring and testing tools

vernier caliper, steel measure

### Accessories

extendable chucking jaws, tap wrench, reducing collars, coolants and lubricants

### Required previous knowledge

drawing comprehension, measuring and checking, thread cutting by hand, centring, boring, counter-boring

### Workshop drawing explanations

M 20: M = metric thread      All surfaces have been machine-finished.

20 = nominal diameter

### Sequence of operations

### Remarks

1. Dimensional inspection

2. Clamp workpiece

Clamping in extendable jaws to Ø 38 mm



- |   |   |
|---|---|
| 3. Clamp tool   | Fix spiral drill to tailstock by means of reducing collars  |
| 4. Set the cutting values for boring                        | Spiral drill is made of quick-cutting steel $v = 25 - 50 \text{ m min}^{-1}$  |
| 5. Undertake a $\varnothing 17.5 \times 38 \text{ mm}$ bore | Ensure proper cooling. Check bore depth with steel measure on the quill. Debur the workpiece.   |
| 6. Set the cutting values for thread cutting                | For steel $v = 4 - 15 \text{ m min}^{-1}$ heeding the material and thread size  |
| 7. Position tap   | Select machine tap. Position the railstock tap to centring of tap.  |
| 8. Cut the tap  | Ensure tap wrench support. Check on proper alignment through the railstock tip.<br>Keep the chip grooves clean by turning the tap back several times.<br>Ensure proper cooling and lubrication. Ensure adherence to 30 mm length. |
| 9. Unload workpiece   |   |
| 10. Dimensional inspection                                  |   |

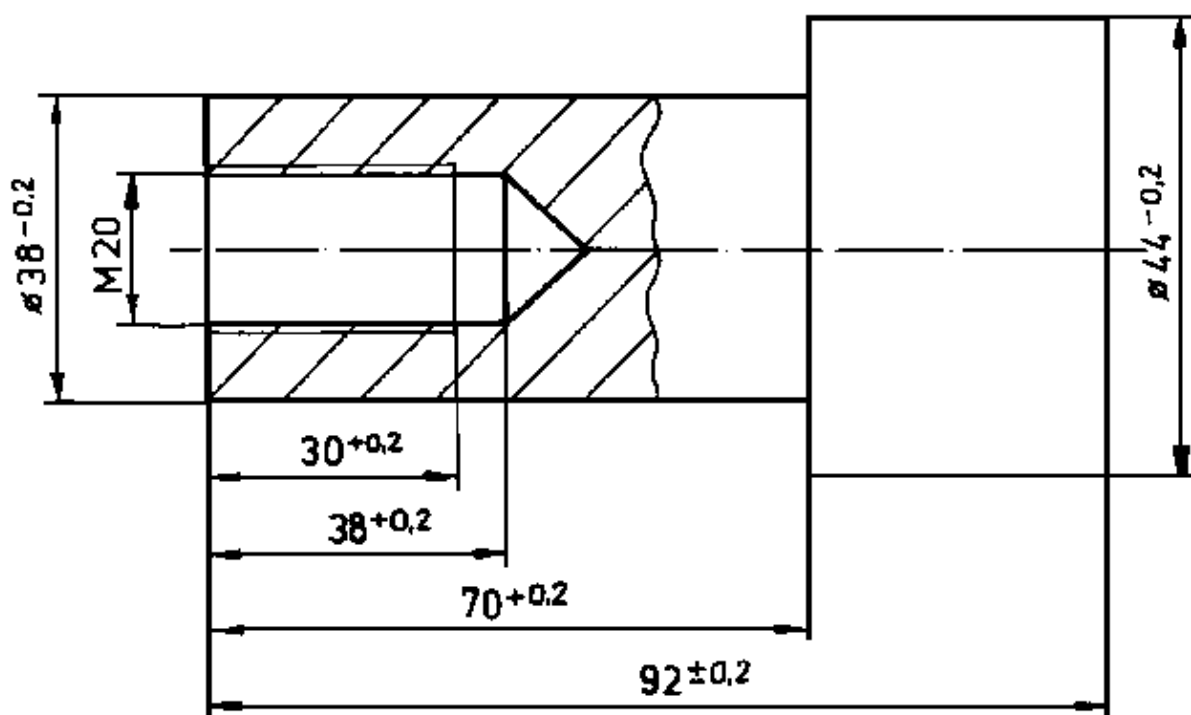
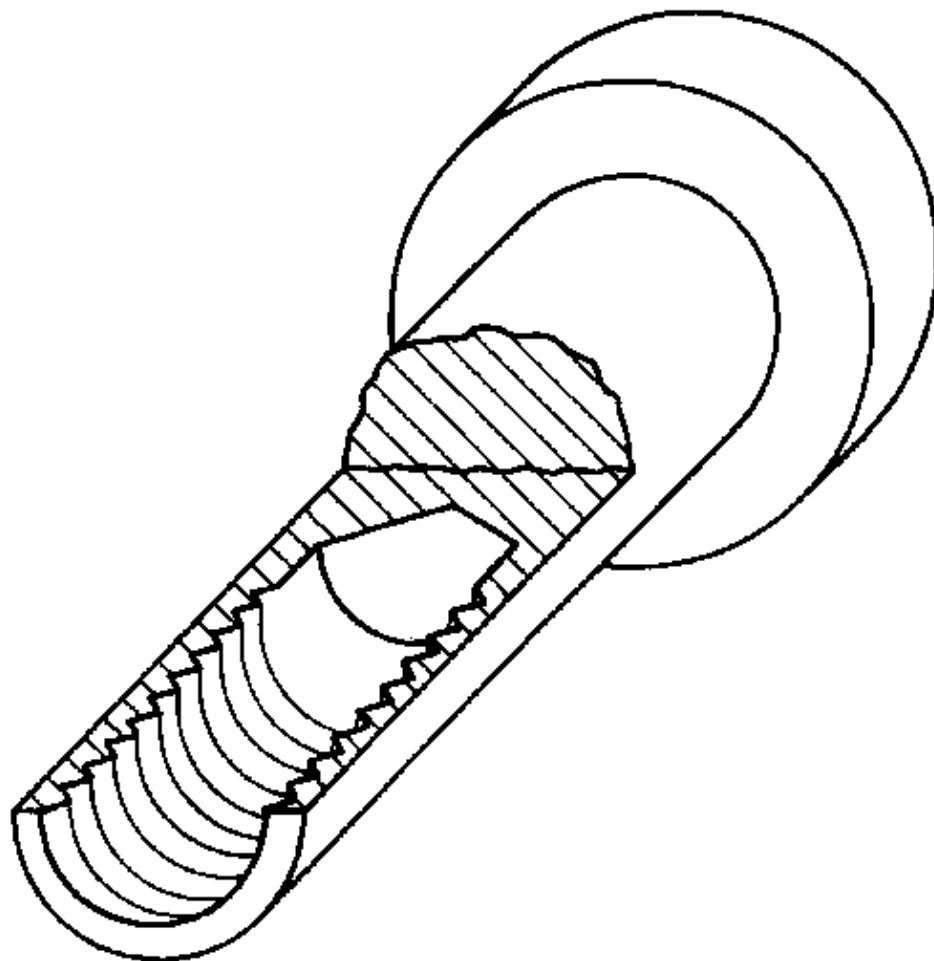

				5.4.
			Piston	3205

Piston

