

**Threaded Joints – Course: Techniques of Fitting and Assembling
Component Parts to Produce Simple Units. Trainees' Handbook of
Lessons**

Table of Contents

<u>Threaded Joints – Course: Techniques of Fitting and Assembling Component Parts to Produce Simple Units. Trainees' Handbook of Lessons</u>	1
<u>Preliminary Remarks</u>	1
<u>Hints on Labour Safety</u>	1
<u>1. Purpose of Threaded Joints</u>	1
<u>2. Selected Types of Bolts and Screws</u>	2
<u>3. Selected Types of Nuts</u>	6
<u>4. Selected Types of Locking Devices for Bolts and Screws</u>	7
<u>5. Selected Types of Washers</u>	10
<u>6. Types of Threaded Joints</u>	11
<u>7. Stresses in Threaded Joint</u>	13
<u>8. Tools</u>	16
<u>9. The Technological Steps of Making Threaded Joints</u>	21
<u>10. Undoing Threaded Joints</u>	26

Threaded Joints – Course: Techniques of Fitting and Assembling Component Parts to Produce Simple Units. Trainees' Handbook of Lessons

**Institut für berufliche Entwicklung e.V.
Berlin**

Original title:
Arbeitsmaterial für den Lernenden
“Schraubverbindungen”

Author: Frank Wenghöfer

First edition © IBE

Institut für berufliche Entwicklung e.V.
Parkstraße 23
13187 Berlin

Order No.: 90–35–3133/2

Preliminary Remarks

The present material has been drawn up for training workers in occupations which require a knowledge of assembly operations in addition to manual and mechanical metal working techniques.

This material contains descriptions of the types of joints which can be made with bolts and nuts or tapped screws. The main technological steps of making and unmaking threaded joints are described. The questions at the end of each section are intended to help the trainees check their newly acquired know-how.

Hints on Labour Safety

Generally, the precautions for safe boring, drilling, counterboring and thread cutting apply. The following points, however, should always be emphasized:

- All tools must be in good condition and used only for the purpose for which they were made.
- All workpieces must be securely held in position for drilling, boring or thread cutting. Excessive holding pressure may damage the work.
- Select tools of the right size for tightening or loosening bolts, nuts and screws. Tools of the wrong size tend to damage the workpiece and may slip off causing injuries.
- Make sure that large parts cannot drop to the ground when the bolts and nuts or screws are removed.
- It is regarded as good craftsmanship to store all tools properly and individual components always together with their counterparts.

1. Purpose of Threaded Joints

Threaded joints are detachable joints of two or more component parts either directly connected with each other or by standardized fasteners, i.e. bolts, nuts and screws.

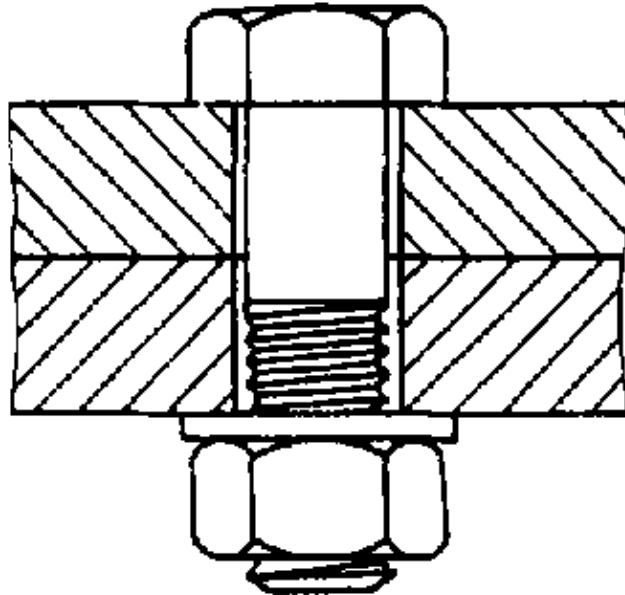

Figure 1. Typical example of a threaded joint

Threaded joints are made

- to keep the component parts of the detachable joint in a desired position,
- to provide the force required to produce a joint and maintain this force for the intended period.,
- to transmit motions and forces of component parts.

Suitable locking devices are used where detachable joints have to be secured against the accidental loosening due to the action of dynamic stresses, such as vibration or shock.

No locking devices are required on temporary joints with fine-pitch thread and joints in which the component parts are self-tightening by the sense of their rotation (e.g. drill chucks on hand drills).

What is a threaded joint?

What requirements must be met by a threaded joint under a dynamic stress?

2. Selected Types of Bolts and Screws

Bolts and screws made of steel are used in machines, steel structures, vehicles and ships because of their strength and toughness. They may be electrically plated with cadmium, zinc, copper or brass.

Bolts and screws made of copper, brass or light metal are used in electrical equipment because they conduct electricity and do not corrode easily.

Hexagon head screws

Used mainly for iron and steel work and in machines generally. There are hexagon head screws of different sizes and lengths of thread in accordance with ISO metric coarse and fine threads.

Typical designation:

Hexagon Head Screw M6 x 20

- Nominal diameter of the ISO metric thread (coarse): 6 mm
- Length of engagement (without the head): 20 mm

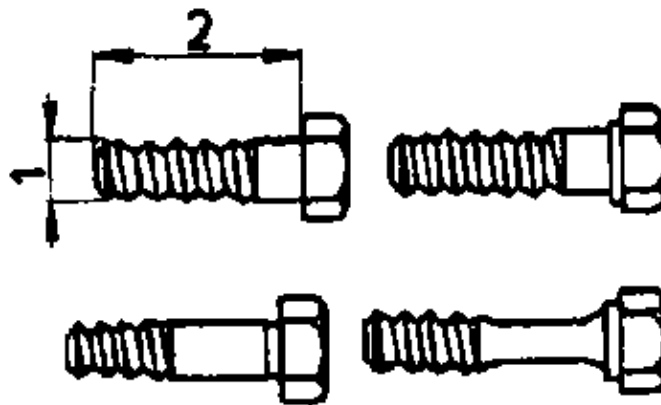

Figure 2. Hexagon head screw

1 nominal diameter, 2 length of engagement

Countersunk head screws

Used in industrial plant and equipment, where safety requires that no head projects the surface of any component. There are countersunk head screws of different sizes and lengths of thread according to ISO metric coarse thread, with different shapes of slots and tops of heads.

Typical designation:

Countersunk bolt with cross slot M6 x 20

- Nominal diameter of the ISO metric coarse thread: 6 mm
- Length of engagement (with the head): 20 mm

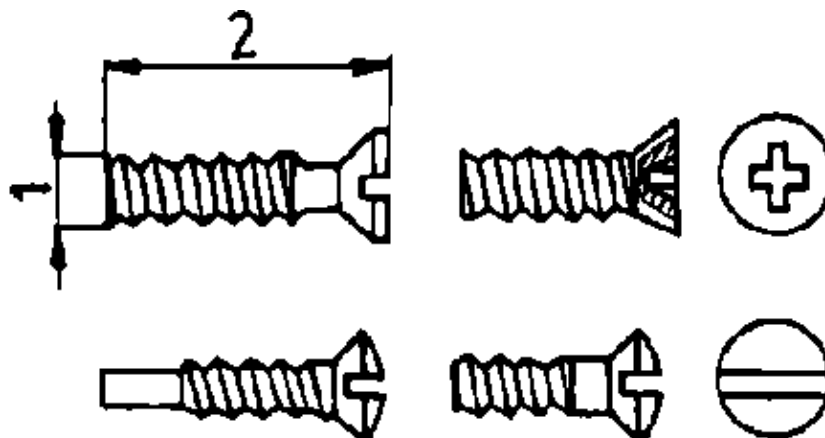

Figure 3. Countersunk-head screw

1 nominal diameter, 2 length of engagement

Cheese head screws

Used for light-weight structured and in general engineering. There are cheese head screws of different sizes and lengths of thread according to ISO metric coarse thread, with different shapes of head. Fillister socket-head screws can accept draw-in forces.

Typical designation:

Cheese head screw with cross slot M6 x 20

- Nominal diameter of the ISO metric coarse thread 6 mm
- Length of engagement (without the head) 20 mm

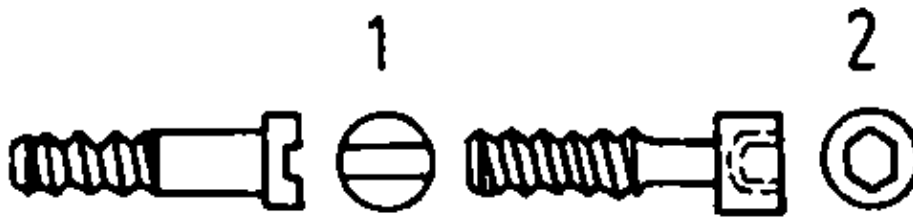

Figure 4. Cheese head screw

1 with cross slot, 2 with hexagonal socket head

Other ISO metric thread bolts and screws

Generally used in the field of engineering, restricted use in machines. There are different sizes and shapes of the head as well as various designs in bolts.

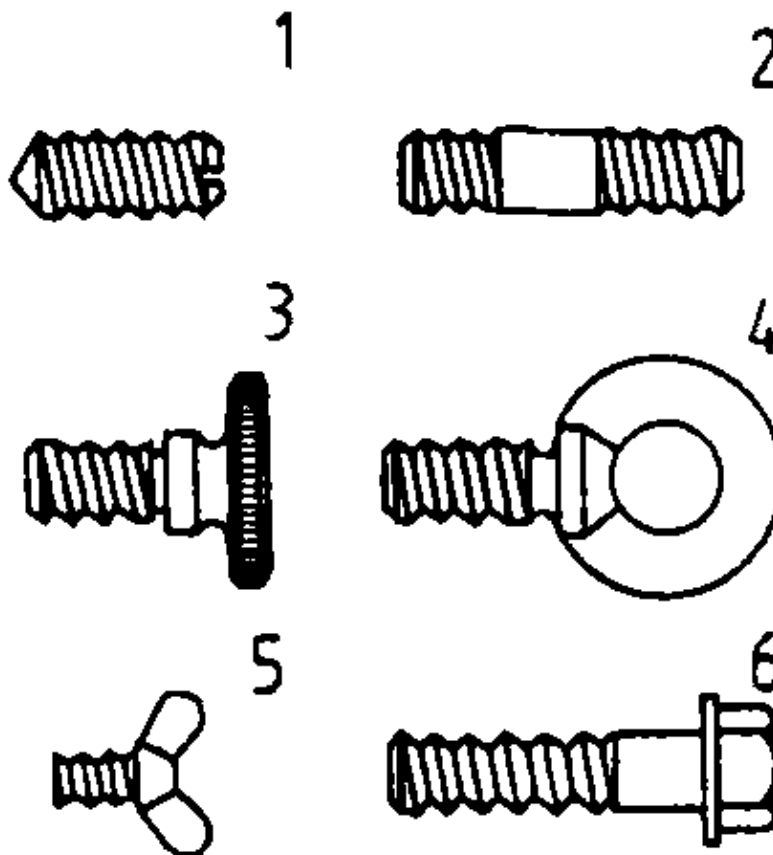

Figure 5. Other bolts and screws

1 threaded pin, 2 stud bolt, 3 knurled head screw, 4 eye-bolt, 5 thumb screw, 6 square bolt

Sheet metal screws

Generally used for car bodies, vessels and light-weight structures. The thread on the cylindrical portion of the screw (with the tip) cuts itself the thread in soft sheets. There are sheet metal screws of different sizes, lengths and shapes of the head. The threaded portion always extends over the entire length of the shank (with the tip), just up to the head.

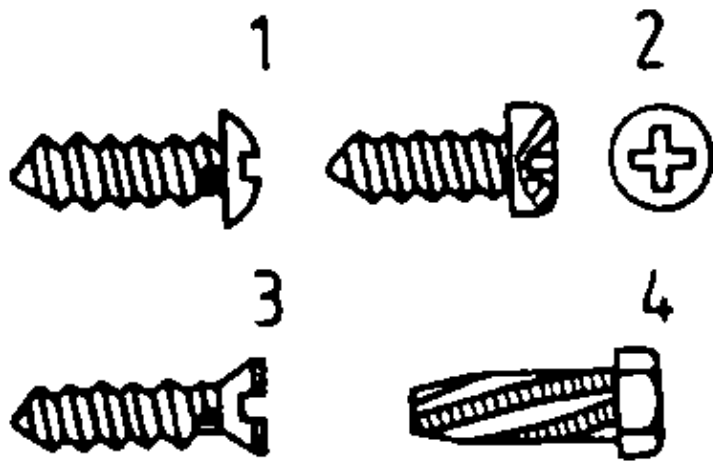

Figure 6. Sheet metal screws

1 button-head sheet metal screw with cross slot, 2 oval head sheet metal screw with intersecting slots, 3 countersunk-head sheet metal screw with cross slot, 4 metric self-tapping screw

Wood screws

Wood screws are used in wood structures. The thread on the tapered portion of the shank (with the tip) cuts itself the thread in the wood. There are wood screws of different sizes, lengths and shapes of the head. Only the tapered portion of the shank is threaded, followed by a cylindrical neck.

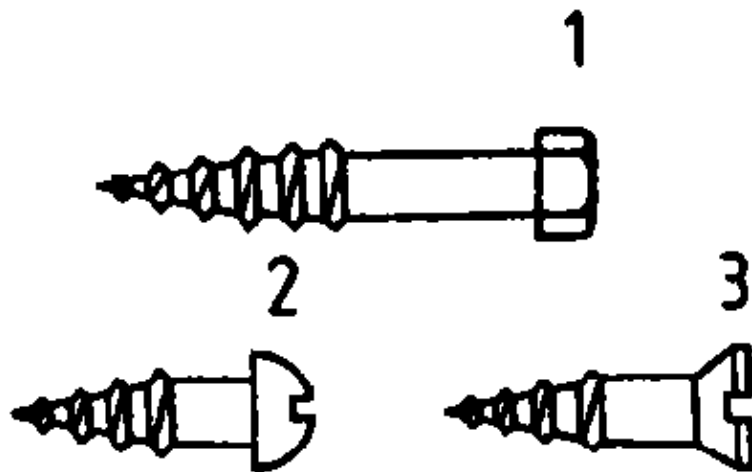

Figure 7. Wood screws

1 hexagon head wood screw, 2 button-head wood screw, 3 countersunk wood screw

Where are countersunk head screws used?

What is the difference in the lengths of engagement of a cheese head screw and a countersunk head screw?

Where does the shape of a sheet metal screw differ from that of a wood screw?

3. Selected Types of Nuts

Nuts are made of the same material as bolts and screws and can have the same kind of plating.

Precise bolt-and-nut joints can only be achieved when they are made of the same materials, grade of material and have the same type of coating.

Hexagon nuts

Used in structural steel engineering and mechanical engineering. There are hexagon nuts of different sizes of ISO metric coarse and fine threads and of flat or wide shape. The cap nut is a special design. Cap nuts provide caps on bolted or screwed joints. They are used as a safety precaution or for better looks. Cap nuts keep the thread clean.

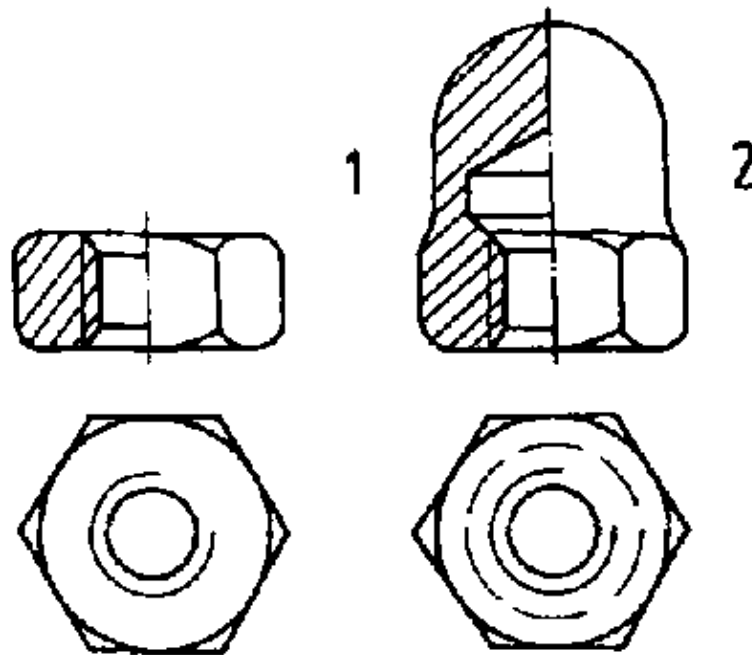

Figure 8. Nuts

1 hexagon nut, 2 cap nut

Knurled nuts and wing nuts

Used for producing detachable joints of component parts by hand, without the use of tools.

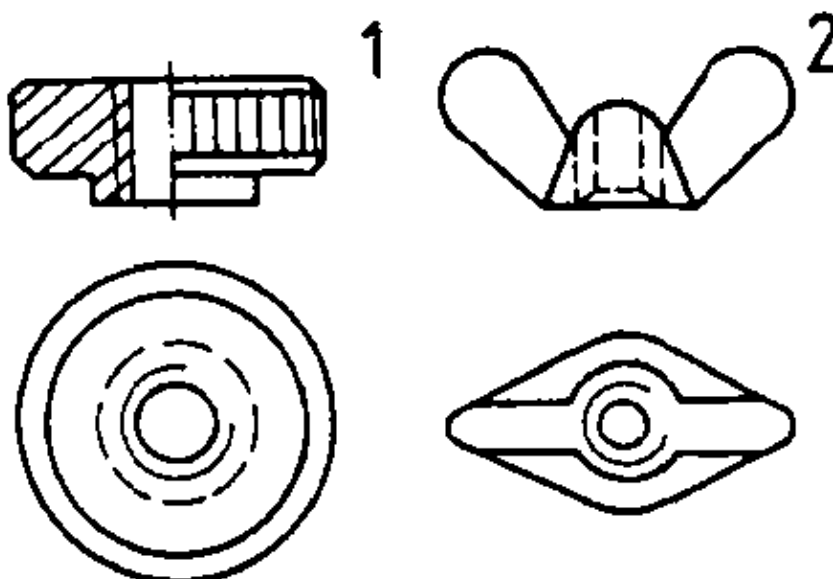

Figure 9. Nuts

1 knurled nut, 2 wing nut

Slotted nuts and nuts with two holes

These nuts are used mainly for electrical components where space is limited and the joint is not easily accessible.

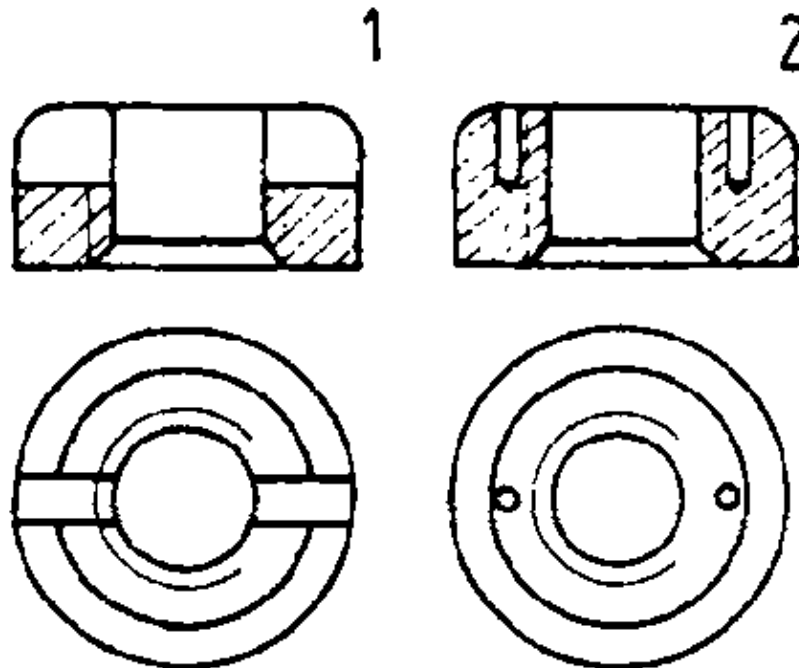

Figure 10. Nuts

1 slotted nut, 2 nut with two holes

What conditions must be satisfied by the materials of which bolts, screws and nuts are made?

Give uses of knurled nuts and wing nuts.

4. Selected Types of Locking Devices for Bolts and Screws

Locking devices can be acting positively, non-positively or by the retention of self-substance.

Locking devices, particularly cotter pins, spring rings and toothed washers, are used only once.

Use new, unused locking devices when re-assembling parts which have been dismantled. Locking devices, once used, will deform permanently and not be safe to use another time.

Non-positive locking devices

These are available mainly as spring lock washers and toothed washers. They maintain a slight tension between the bolt, or nut, and the component to which they are fastened.

The sharp edges on the spring lock washers and toothed lock washers have a “seizing” effect on the component tightened in the joint, thus preventing it from coming loose accidentally.

An additional locking effect can be obtained on bolts with a long, projecting shank by screwing a counternut on the projecting shank. Both nuts must be screwed sufficiently tight. The friction on the thread flanks prevents the nuts from coming loose.

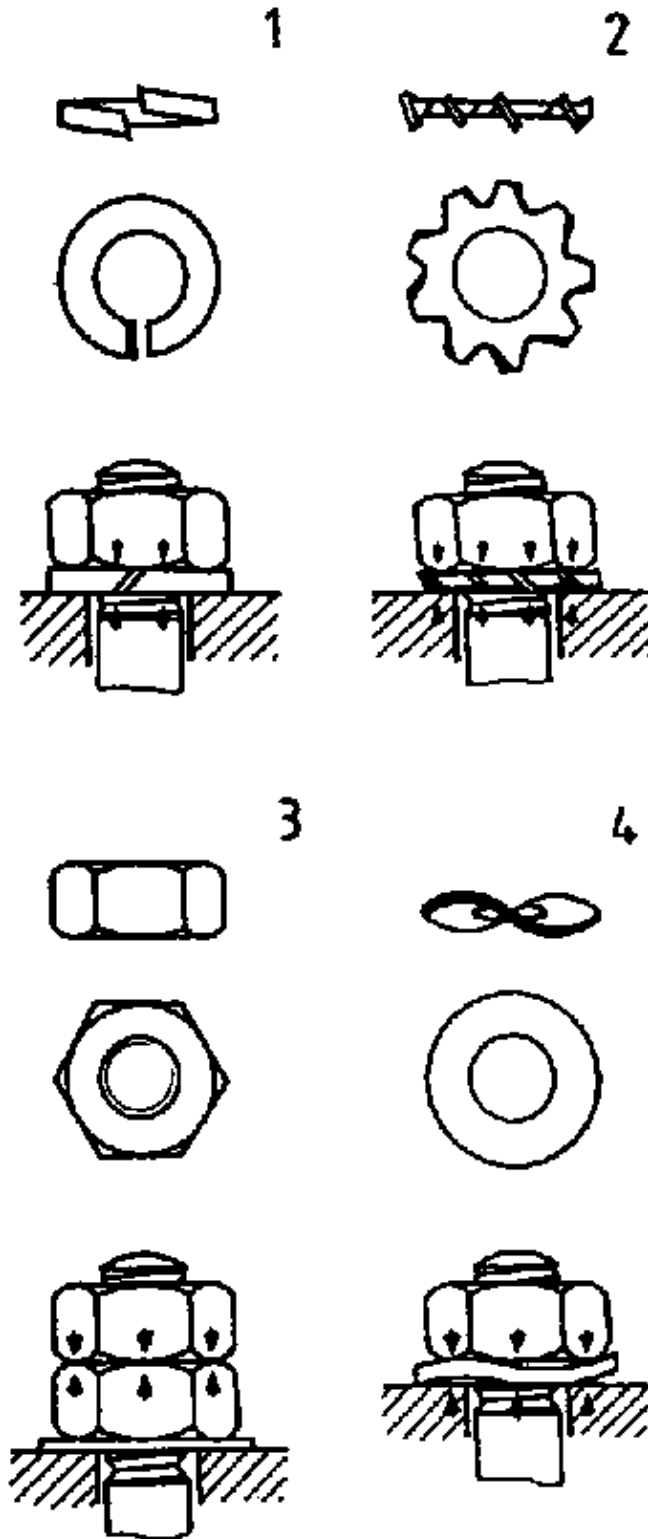

Figure 11. Non-positive locking by

1 spring ring, 2 toothed washer, 3 counter nut, 4 spring lock washer

Positive locking devices

These are available mainly as locking plates, retaining rings and crown nuts with split pins. They are used primarily with hexagon head screws and where their shape prevents the joint from coming loose.

Locking plates and retaining rings are provided with tangs or lugs, which are fastened to the component in the joint and the connecting part by blows with a hammer. When crown nuts are used, a hole must be drilled through the threaded portion, which takes up the cotter pin, after nut has been tightened.

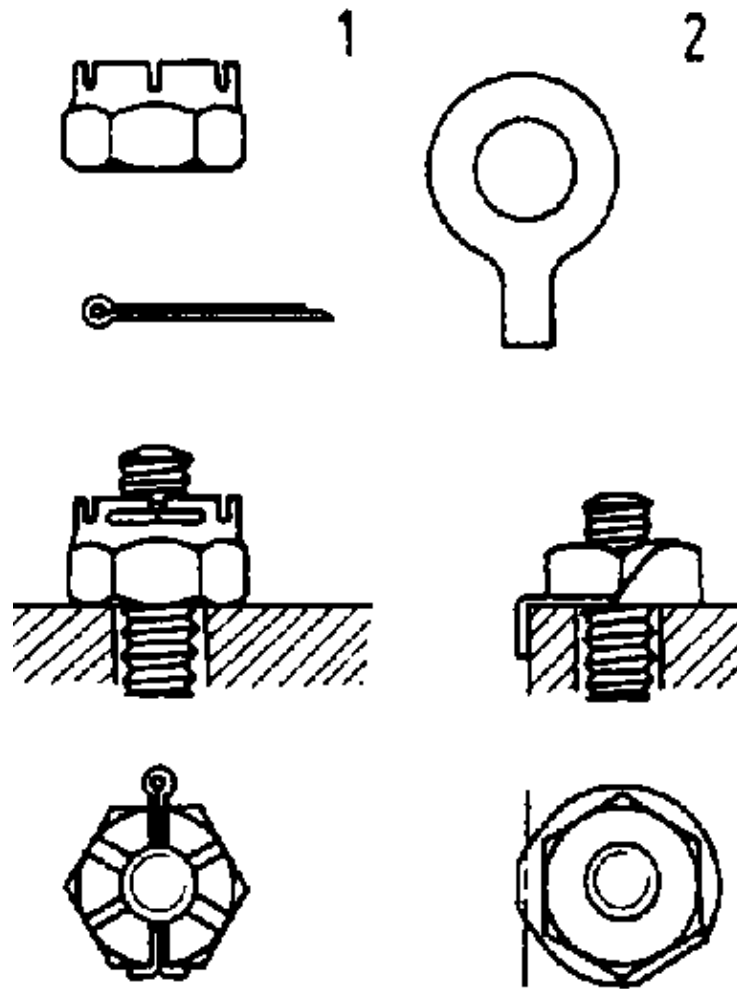

Figure 12. Positive locking by

1 crown nut with split pin, 2 locking plate with tang

Locking by retention of self-substance

The locking effect is achieved by the application of paint, varnish or paste. Used primarily on electrical assemblies and in precision instruments. Where the forces acting on the joint are slight, the locking effect is sufficiently strong and provides protection against tampering.

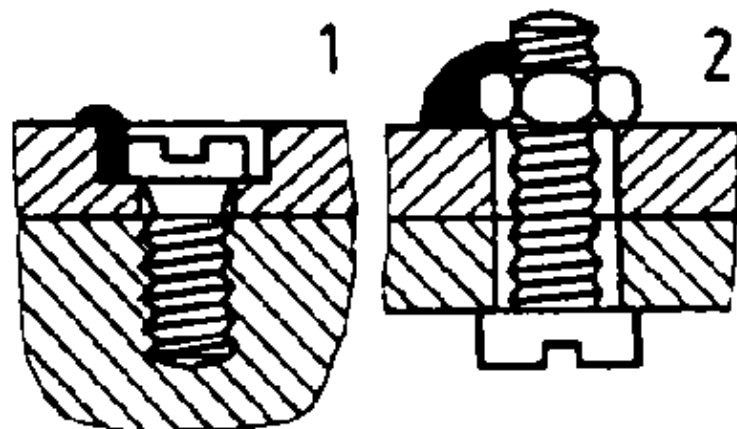

Figure 13. Locking by retention of paint

1 on the bolt head at a blind bore, 2 on the nut at a through bore

Identify elements of locking devices which must be used once only.

Suggest an effective way of locking with the shank of the bolt projecting beyond the nut.

5. Selected Types of Washers

Washers are placed under the heads of bolts or screws or under nuts, where

- the bearing faces are not properly machined,
- bolts, screws and nuts are to be tightened on oblong holes,
- slopes of the bearing face must be compensated.

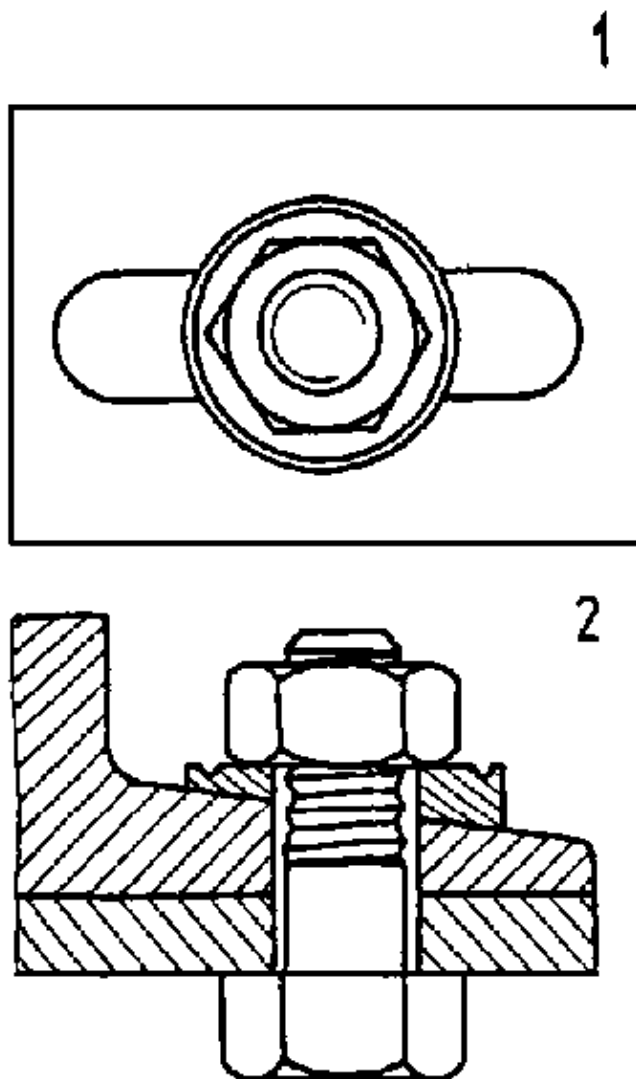

Figure 14. Uses of washers

1 washer on an oblong hole, 2 wedge-shaped washer on an inclined face

Washers are made of the same materials as bolts, screws and nuts and can have the same kind of plating.

There are washers of different sizes and thicknesses and to account for different properties in the proportion of hole diameter and width of the edge.

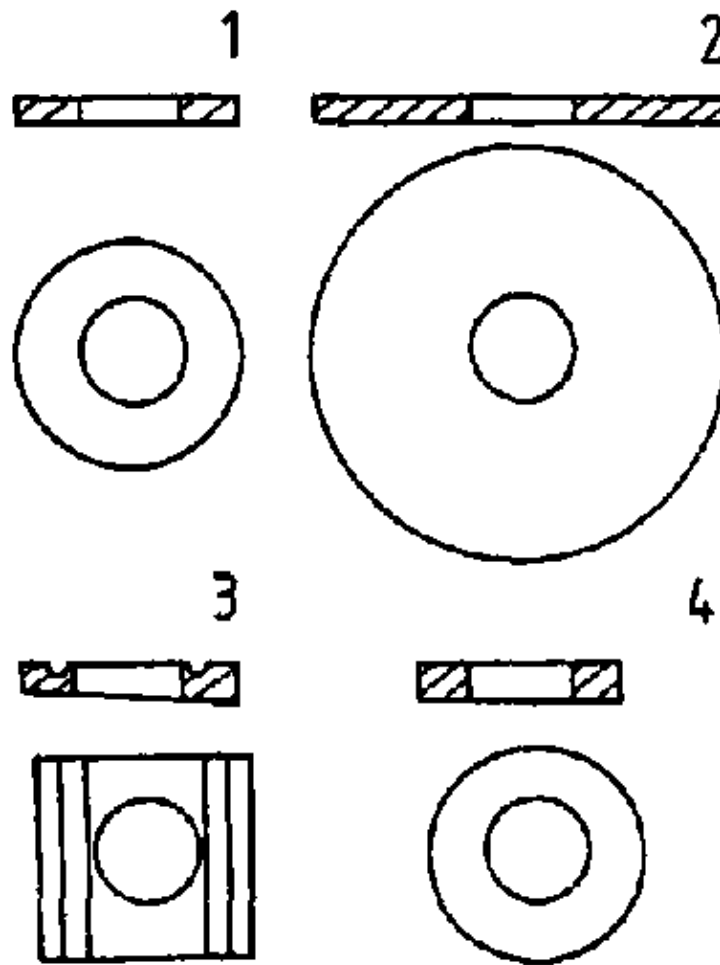

Figure 15. Washers

1 common washers for bolts and screws, 2 washers for elongated holes, 3 wedge-shaped washer for inclined surfaces, 4 washer for iron and steel work

Give uses of washers.

6. Types of Threaded Joints

Threaded joints are specified below for the way a joint is made, or for its purpose.

Direct joints

The component parts to be joined have internal or external thread and are directly screwed together. No additional fastening elements are needed.

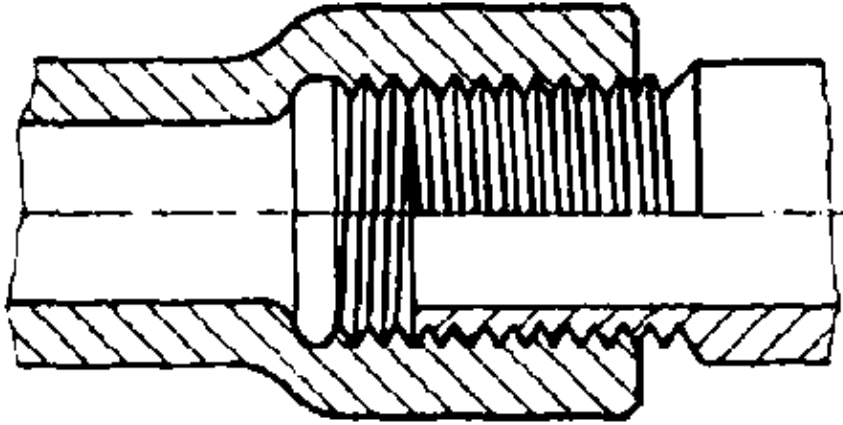

Figure 16. Direct joint

Indirect joints

The component parts to be joined are held together by standardized components, i.e. bolts, screws and nuts. Locking devices and washers may be used additionally.

Where a component part has a female thread, the joint may be made without a nut. The walls of the work-piece must be sufficiently thick for this kind of joint.

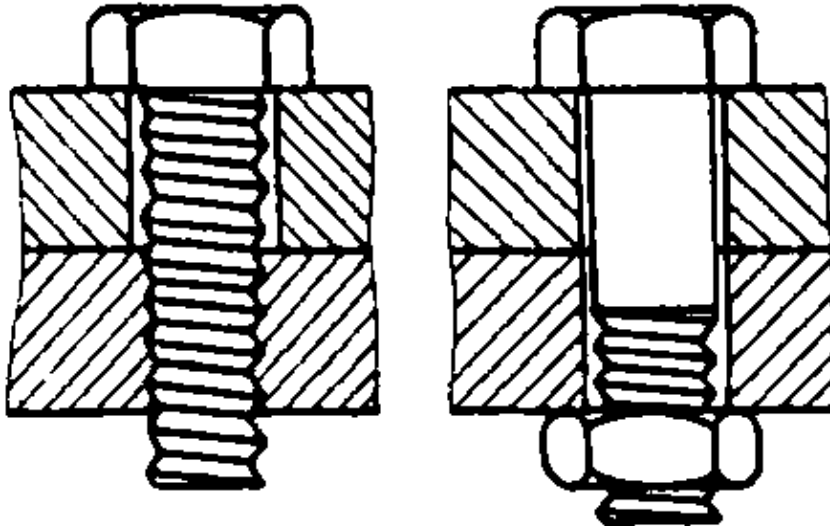

Figure 17. Indirect joint

Fastening joints

The component parts are to be joined directly or indirectly only for the purpose of connecting them. The vee-thread, ISO metric vee-thread or Whitworth thread, are the preferred types of thread. Both threads are self-retaining.

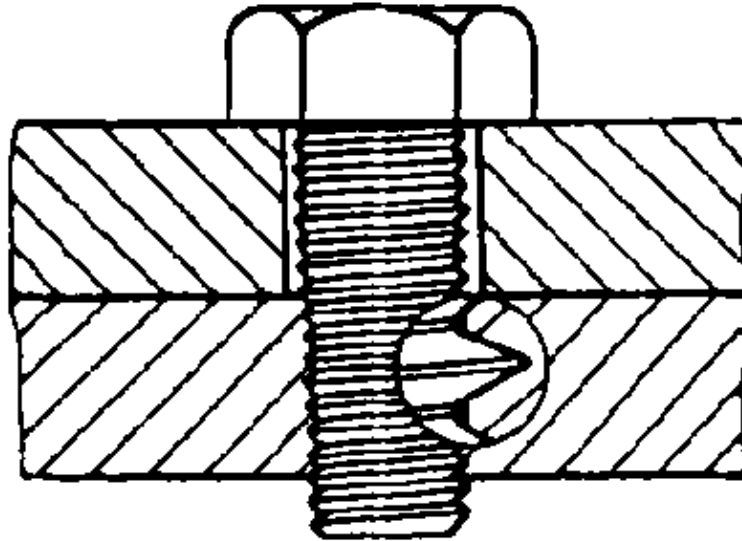

Figure 18. Screwed joint for fastening purpose

Adjustable joints

The component parts are joined for the purpose of connecting them and transmitting movements or forces. The preferred types of thread are round thread, acme standard screw thread or saw-tooth thread.

These are less self-retaining.

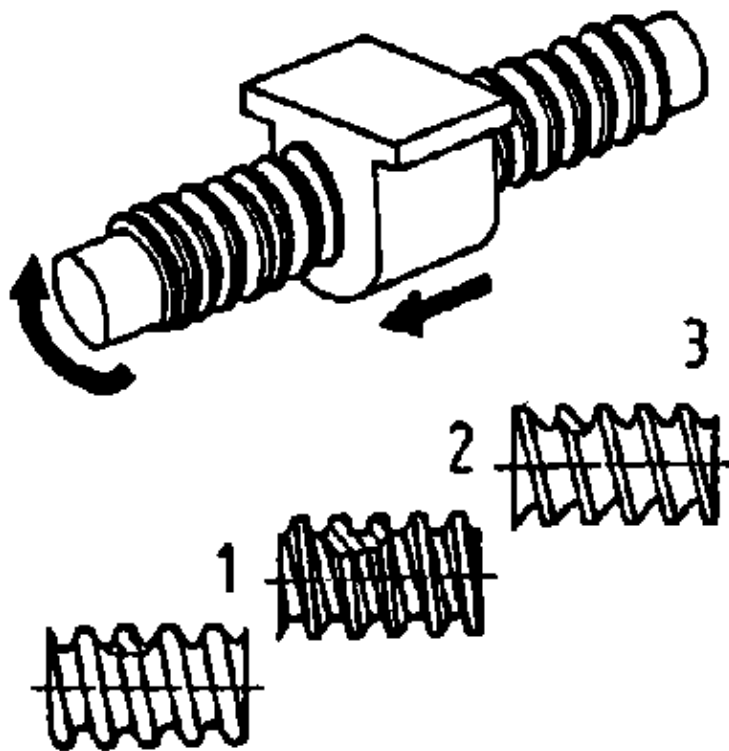

Figure 19. Adjustable joint

1 round thread, 2 acme standard screw thread, 3 saw-tooth thread

Name different types of threaded joints.

7. Stresses in Threaded Joint

A threaded joint is formed when two parts, one with an internal thread and the other with an external thread of the same description are joined by turning them in opposite directions. A positive joint exists between the

internal and the external thread, while friction produces a non-positive connection between thread flanks. The latter prevents an accidental loosening of the joint (i.e. it is self-retaining) when the pitch of thread is low.

- Shallow pitch – more self-retention
- Steep pitch – less self-retention

Indirect joints for fastening purposes are made by firmly pressing the component parts together. The intensity of pressure produces a non-positive joint between them. When the contact pressure is overcome by the service stress which acts laterally, the threaded bolt comes under shearing stress.

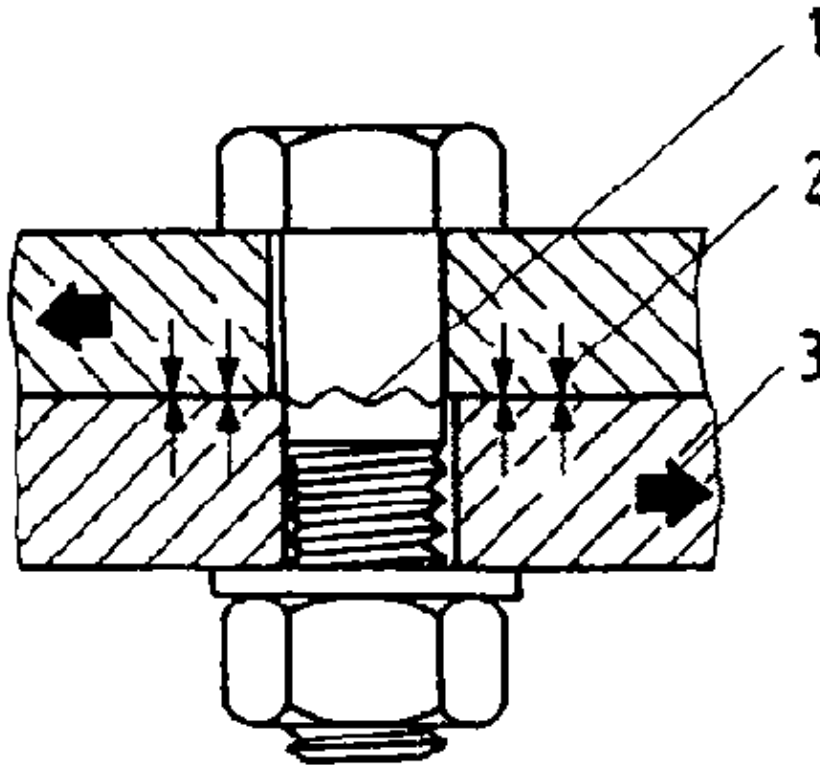

Figure 20. Shearing stress at a fastening screwed joint

1 shearing stress, 2 contact stress by prestressing, 3 laterally acting service stresses

When a joint for fastening purposes is tightened, the threaded bolt will expand and produce “pre-stressing”. The elasticity of the threaded bolt which counteracts the expansion, causes the bolt to press the component parts of the joint together tightly. When external (tensile or compressive) forces act along the longitudinal axis of a threaded joint, a “service stress” is produced in addition to the pre-stressing.

Tensile forces – act in the direction of the prestress and increase the stress in the bolt.

Compressive forces – act in the opposite direction of the prestress and lessen the stress in the bolt.

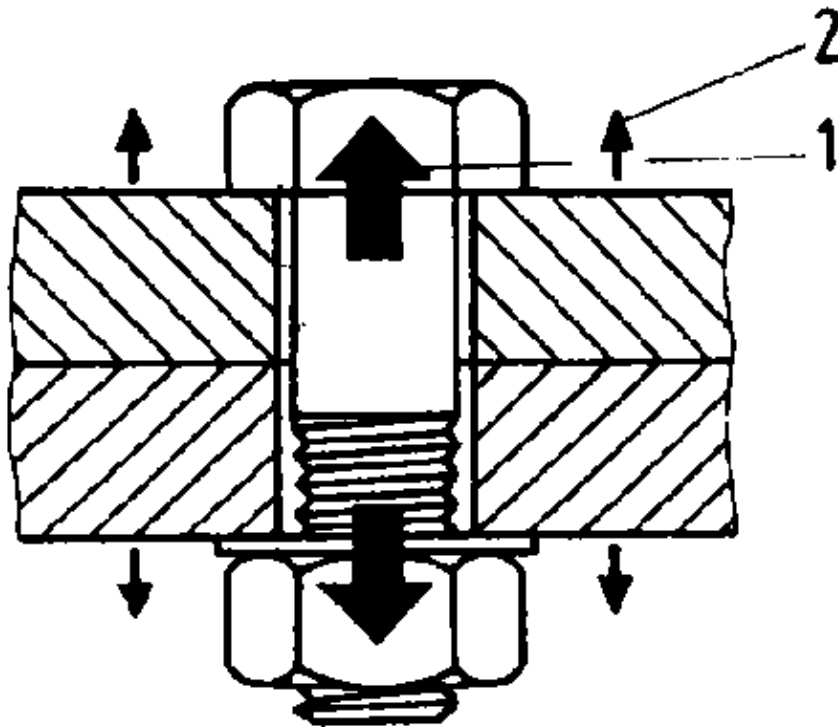

Figure 21. Tensile stress at a screwed joint for fastening

1 prestressing, 2 service tensile stress

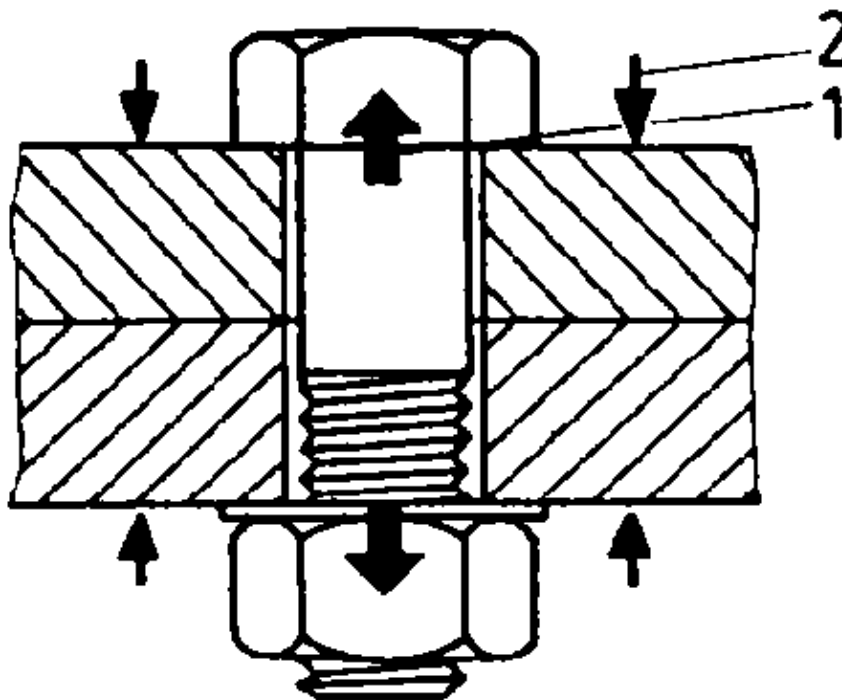

Figure 22. Compressive stress at a screwed joint for fastening

1 prestressing, 2 service compressive stress

Note:

- The sum of service stress forces and prestressing forces must be higher than the maximum permissible tensile strength of a bolt. Otherwise the bolt will fail.
- Compressive service stress forces must never neutralize the prestressing force in a threaded bolt. Otherwise the threaded joint will come apart.

– A threaded bolt will be bent and eventually fail when the bearing face for the bolt head is not level. Remember: Bearing faces for bolt heads must always be level.

Identify the strain and stress of a thread for fastening purposes is exposed to.

Name different types of stress in threaded joints.

8. Tools

Drills, countersinks, counterbores, thread taps, threading dies

There are various kinds of drills, 60° included angle countersinks, cutting dies, serial taps and nut taps for producing through bores and tapped holes. Threading dies are preferred for re-threading screws or threaded bolts.

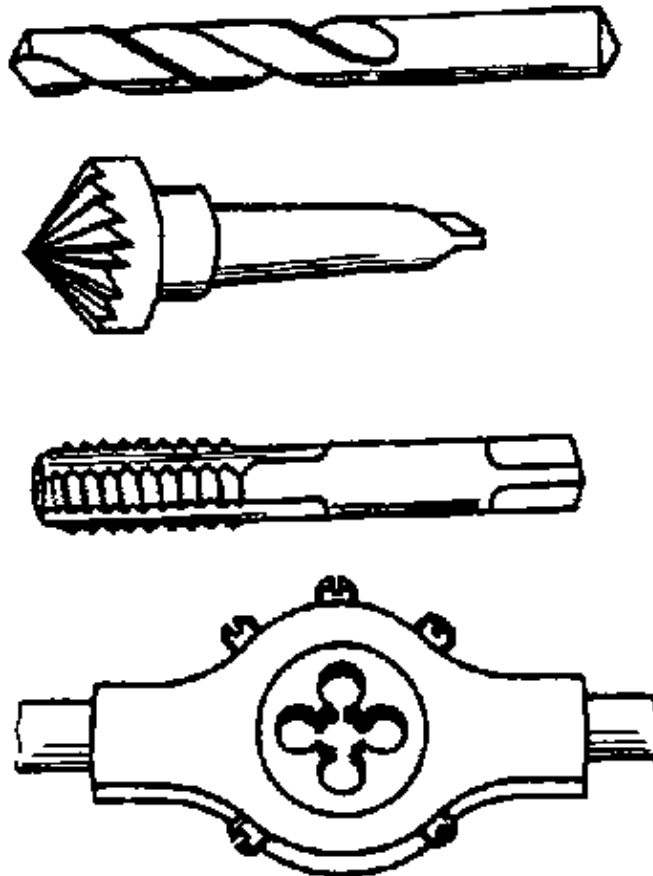

Figure 23. Drills, countersinks, thread-tap, threading die

Die stock

There are various die stocks for larger ISO metric threads (12 mm diameter and more) for cutting thread in bolts and die stocks for Whitworth pipe thread for the direct joining of pipes.

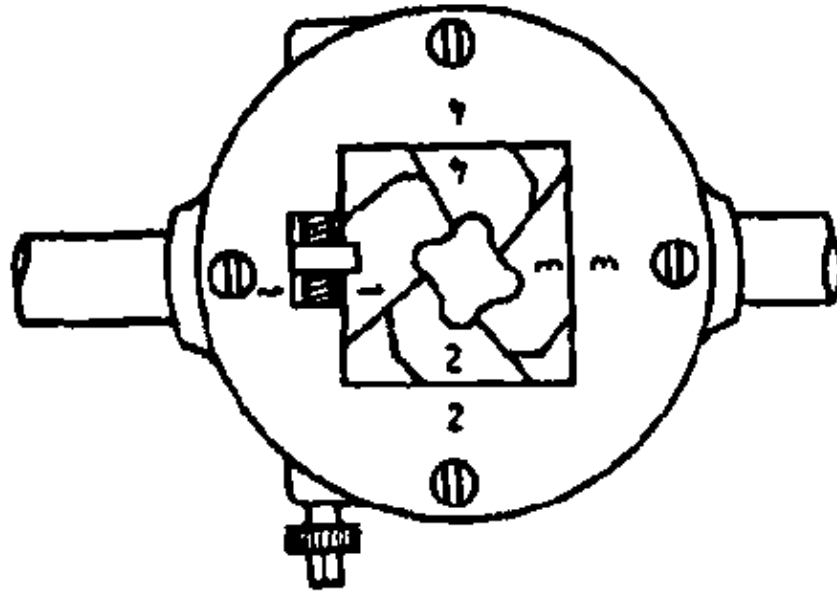

Figure 24. Die stock

Screw drivers

Screw drivers are used for tightening or screws with a slot across or intersecting slots. Angular designs of screw drivers are known for screws to which access is difficult.

If between the blade and the slot there is a wide clearance, do not use the screw driver. The tolerance between the blade thickness and the slot should be close. The blade width should be marginally smaller than the diameter of the screw head.

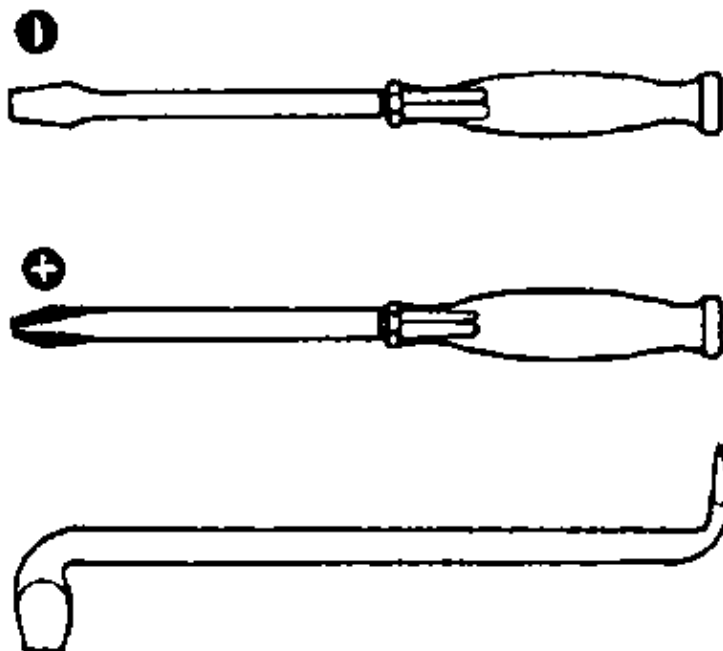

Figure 25. Screw driver

Open ended wrenches

There are open ended wrenches of different standard sizes for tightening and loosening hexagon head bolts, screws and nuts. The lengths of open end wrenches are such that the ratio of the median force applied by human arm and nominal thread diameter does not exceed the permissible shearing stress produced when tightening a bolt, screw or nut.

Never use a piece of tube to extend the length of an open ended wrench in a attempt to apply a higher tightening force. The prestress in the joint will be too high.

Nominal thread diameter	M4	M5	M6	M8	M10	M12	M16	M20
Dimension across jaws (mm)	7	8	10	13	17	19	24	30

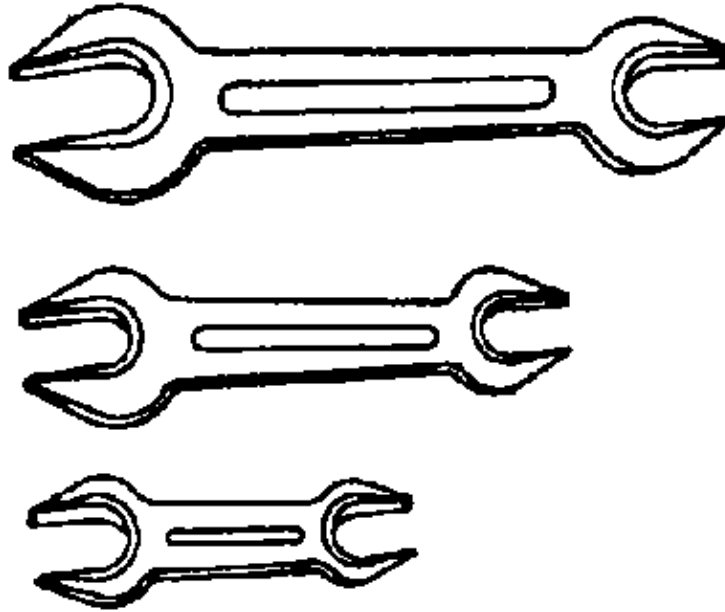

Figure 26. Open ended wrench

Ring spanners

There are cranked and flat types of ring spanners of different sizes for the tightening and loosening of hexagon head bolts, screws and nuts of higher strength specifications.

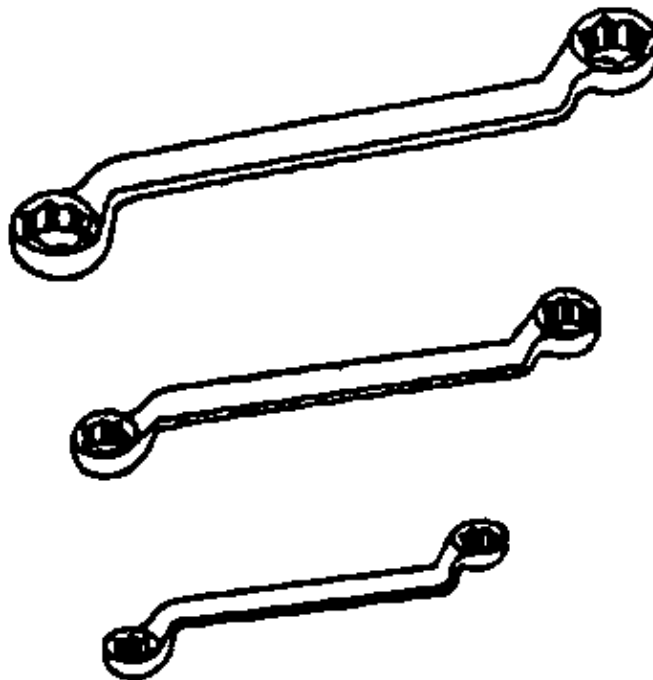

Figure 27. Ring spanner

Box spanners

There are box spanners of different sizes for use on hexagon head bolts, screws and nuts where these are accessible only in the axial direction.

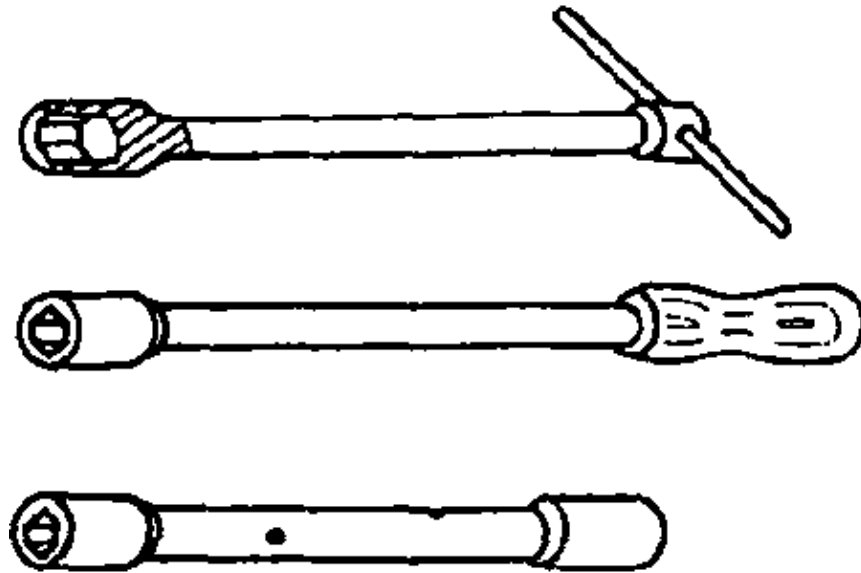

Figure 28. Box spanner

Hexagon pin-type wrenches

There are hexagon pin-type wrenches of different sizes for the tightening and loosening of hexagonal socket head screws.

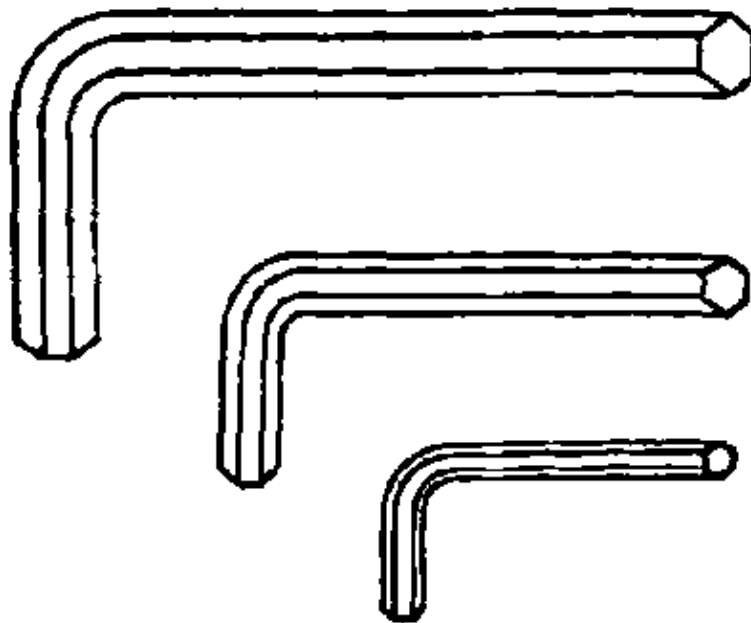

Figure 29. Hexagon pin-type wrench

Adjustable wrenches

Adjustable wrenches are used on hexagon head bolts, screws and nuts where there are different head sizes and no sets of open ended wrenches are available.

Adjustable wrenches replace certain size ranges of open ended wrenches, but they are heavier and less handy.

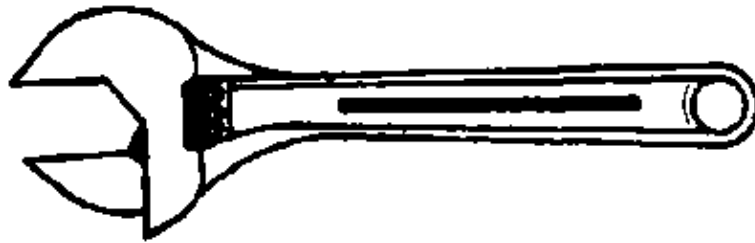

Figure 30. Adjustable wrench

Torque spanners

Several types of torque spanners are available. They are used where high-strength bolted or screwed joints are required to have a specific torque (tightening torque) or where there are several bolted or screwed joints on one component part and their prestressing is to be the same. The torque can be read at a dial during tightening.

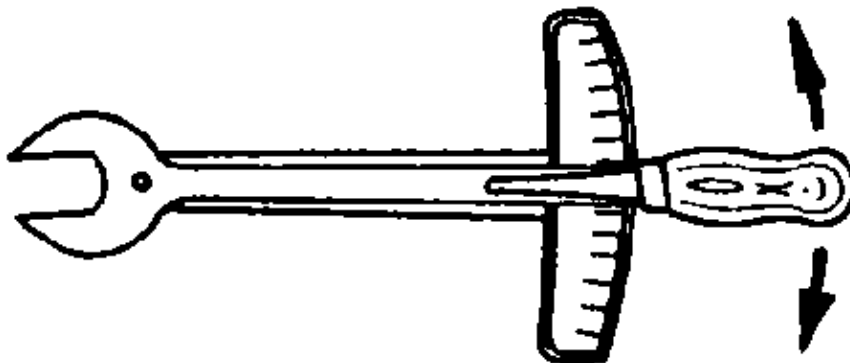

Figure 31. Torque spanner

Electrically actuated wrenches

Electrically actuated wrenches are used in industrial volume production. Various tools can be used on electrically actuated wrenches to tighten or loosen different types of bolts, screws and nuts. Electrically actuated wrenches may be adjustable for torque.

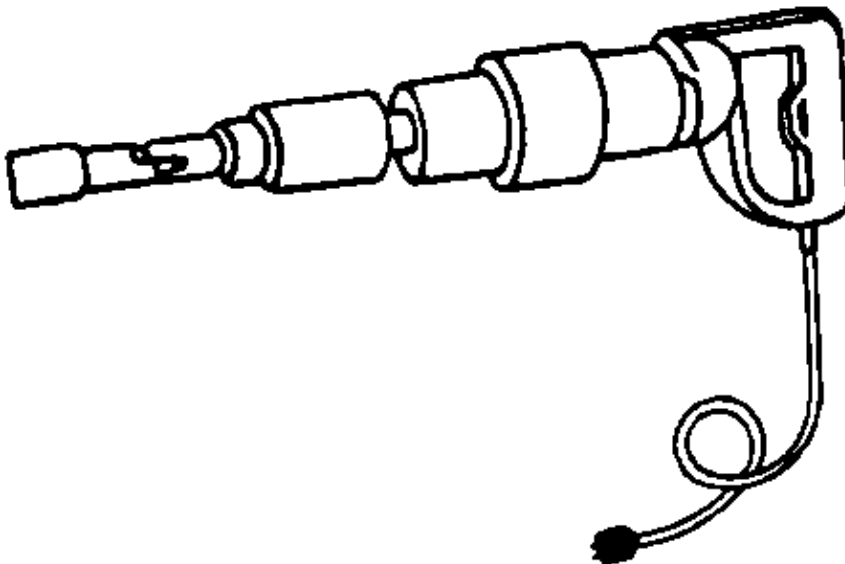

Figure 32. Electrically actuated wrench

What may happen when the blade of a screw driver is too narrow?

What may happen when an extension is used on the open ended wrench for tightening a threaded joint?

Name applications of the torque spanner.

9. The Technological Steps of Making Threaded Joints

The preparations for direct threaded joints differ from those for indirect joints.

9.1. Direct Joints

Direct joints can be found mainly in parts or assemblies of machines. Most threads are cut mechanically and the component parts are simply joined by screwing. Make sure that the parts which are to be joined by screwing coincide in their nominal thread diameters, pitch and sense.

Example:

Drill chuck on a machine spindle in a hand drill.
Closing caps on containers.

Pipes may be directly joined by screwing as well. Most connecting parts (pipe bells) and fittings (angles, bends) are manufactured industrially and only an external thread needs to be cut on the pipe.

Task:

An unthreaded 1-inch (25-mm) steel pipe is to be screwed into an elbow fitting having internal thread. A short external thread is to be cut on the pipe.

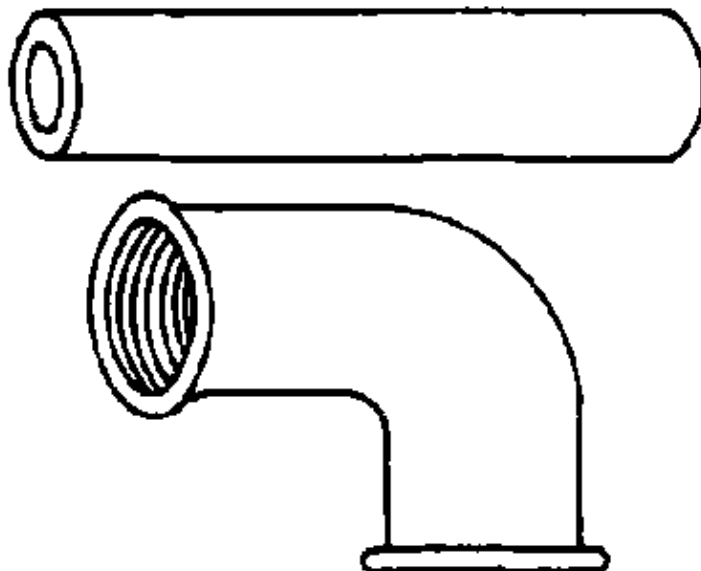

Figure 33. Pipe and elbow fitting

Sequence of operation:

1. Prepare the die stock

– Mount the cutting dies with pipe thread R 1-inch in the sequence of operations 1 to 4.

- Set the fine adjustment for the entering tap.
 - Open the pilot.
2. Chuck the pipe, apply cutting fluid to the deburred end of the pipe.
 3. Place the die stock, pilot end first, on the pipe end, and adjust the pilot.
 4. Make an entering cut and rough cut over 19 mm length by turning evenly in clockwise direction. Then loosen the clamping screw and break the burr with a short jerk to the right.

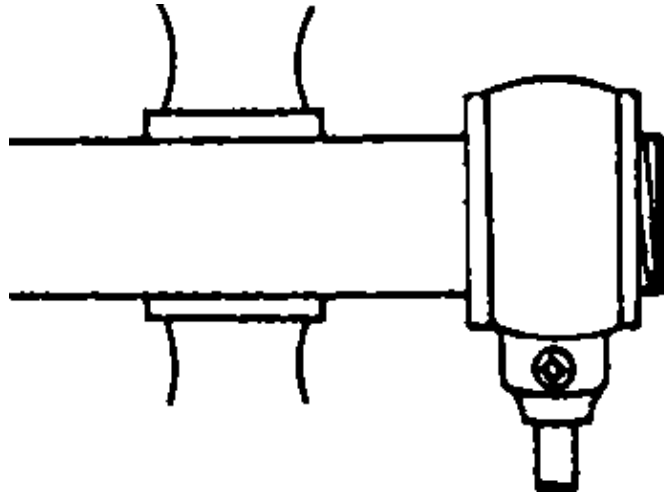

Figure 34. Cutting a pipe thread

5. Open the die stock and remove it. (Do not turn it to remove it).
6. Set the fine adjustment for re-threading.
7. Place the die stock on the pipe and adjust the pilot.
8. Re-thread, then loosen the clamping screw and deburr the pipe.
9. Open the stock and remove it from the pipe (Do not turn it to remove it).
10. Clean the thread and apply some grease to it.
11. Screw the pipe into the elbow fitting until it stops. Use a pipe wrench.

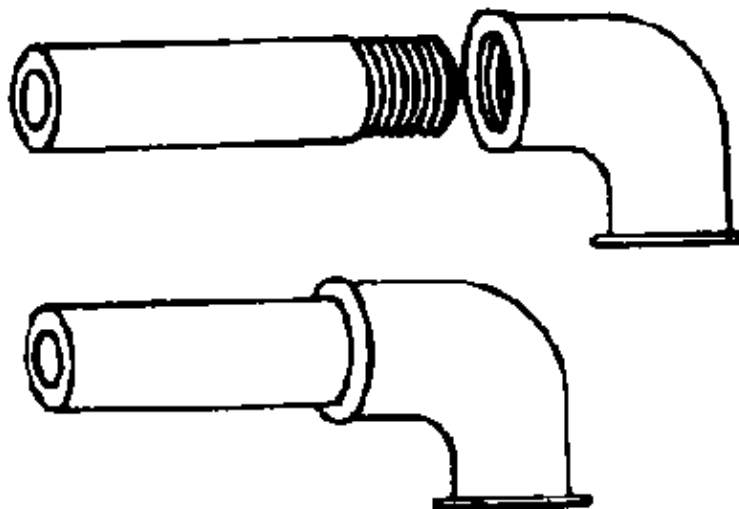

Figure 35. Making a joint by screwing

Note:

– Where tight joints are to be made of pipes, apply a packing of hemp tightly, starting from the front end of the pipe backwards. Apply in right-hand direction if the thread is right-hand. Then apply acid-free grease and screw into the internal thread, first by hand, then with a pipe wrench.

– Where the pipe joint is to be made as a part of a permanent pipe installation, use a pipe with long thread to ensure that the screwed joint can be loosened even after a long time. Screw a pipe bell over the full length of the thread. Use short thread on the pipe and press it flush on the long thread. Then turn back the pipe bell and join both pipes without twisting either of them.

9.2. Indirect Joints

Most threaded joints for fastening purposes are indirect joints. When making the joint, make sure that the nominal diameters, pitches and senses of rotation as well the material of bolts, screws and nuts coincide.

There are two main ways of making a threaded joint the indirect way.

1. Bolt – component parts – nut
2. Bolt – component parts – component part with female thread

Task:

Two steel parts are to be joined firmly by a hexagon head bolt and a nut. The bolted joint will be exposed to dynamic stress, hence it must be locked.

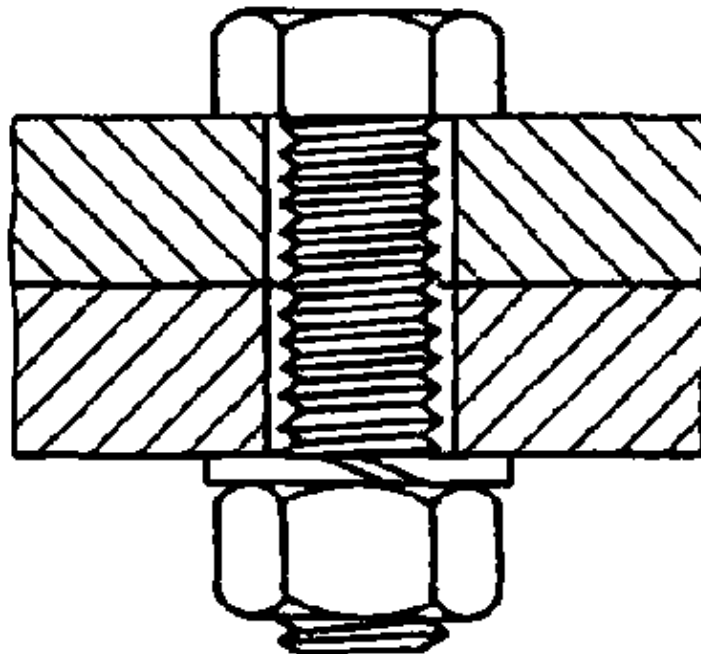

Figure 36. Joint made with a bolt and a nut, locked with a spring ring

Sequence of operations:

1. Mark out the steel parts and punch a mark for the bore hole centres.
2. Set up the steel parts for drilling. Drill holes together, where possible. (The bore hole diameter should be slightly bigger than the thread diameter).
3. Deburr both ends of the bore hole with a spotfacer.
4. Apply some grease to the bolt. Insert the bolt into the bore hole and place a locking element (such as a spring ring) onto the end projecting from the hole.
5. Screw on a nut for a few turns by hand, then tighten with an open ended wrench.

Note:

- Use washers where the surface of the work is unclean or smoothen the surface.
- Where the bore hole is provided when the part is supplied, use a flat or pilot-type countersink to level the face which bears the bolt head.

Task:

Three steel parts are to be joined firmly by a hexagon head bolt. The receiving thread is to be in the last of the three component parts. The bolted joint will be exposed to dynamic stress.

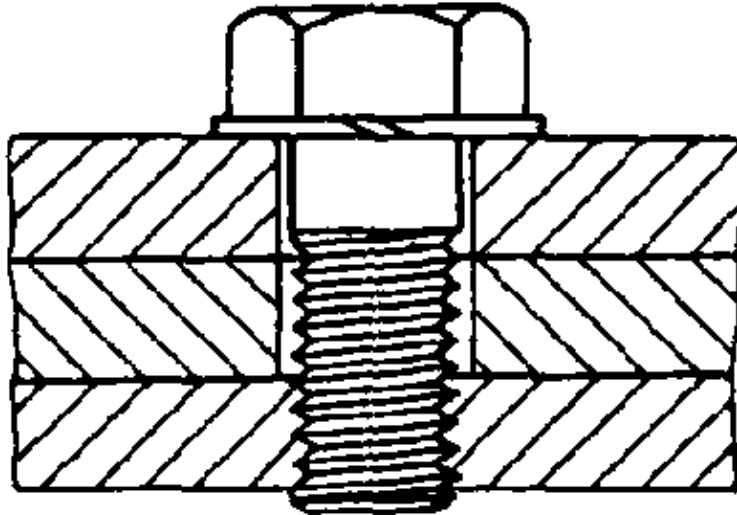

Figure 37. Joint made with a bolt and a component part, locked with a spring ring

Sequence of operations:

1. Mark out all steel parts, punch a mark for the bore hole centre.
2. Set up the steel parts for drilling, drill the holes together, if possible. The bore hole diameter should be of the same dimension as the minor diameter of the thread.

• Use the following formula to calculate the drill diameter:

$$D = N - S$$

where:

- D – minor diameter of the thread/hole diameter
- N – nominal diameter
- S – pitch

• For blind holes, consider the length of thread engagement and the run-out depth of the thread tap. The tap hole must be made deeper by that dimension. Formula:

$$T_B = T_G + T_A$$

where:

- T_B – hole depth
- T_G – depth of thread
- T_A – depth of run-out

Where no values can be taken from handy tables, calculate approximate values using the following formula:

$$T_A = 0.7 \cdot D$$

- Read the speed of the drill from the table or calculate it with the following formula:

$$n = \frac{V \cdot 1000}{D \cdot 3.14}$$

where:

- n – speed (rpm)
- V – cutting speed (m/min)

3. Take the component parts apart and work them separately. Face both sides of the hole with a 60° included angle countersink. The hole to be faced is that in the last component part in the joint. The sink diameter is to be the same as the thread diameter.

Then cut the thread.

$$D_s = N$$

4. Bore an oversized hole in the two other component parts. The dimension of the oversize depends on the nominal diameter of the bore:

Nominal diameter	M3	M4	M5	M6	M8	M10	M12	M16	M20
Through hole diameter	3.4	4.5	5.5	6.6	9	11	14	18	22

5. Put the component parts are together, push the locking element, such as a spring ring, onto the threaded bolt and apply some grease to the threaded portion. Screw in by hand and then tighten with an open ended wrench.

Five details of making a tapped hole for a screw.

Rules for assembly:

- Where several component parts are screwed together without a nut, the receiving thread must only be in the last part as seen from the head of the screw. All in between parts have through holes.
- Heads of bolts and screws, when they are not to rise above the surface of the workpiece, must be mounted flush. Cheese head screws are countersunk with a piloted counterbore. Hat-headed screws are countersunk with a 90° included angle countersink.
- Locking devices are always assembled at the side with the highest torque.
- Joints which consist of a bolt or screw and a nut always have the highest torque on the nut. Hence, the head of the bolt or screw is held and the nut is tightend.
- Always assemble a locking component at the nut end in joints which consist of a bolt or screw and a nut.
- Where several nuts are tightened on a component part (for example, the lid of a container), always start from the centre and proceed outwardly, crosswise.

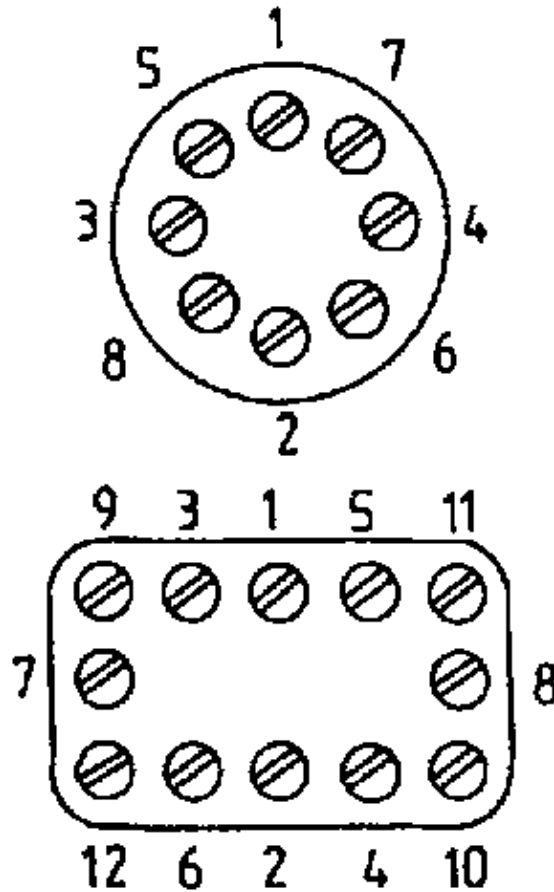

Figure 38. Sequence of operations in tightening a screwed joint

Where several component parts are to be joined by a screw, which part must have a receiving thread?

How will you proceed in tightening a joint which consists of a bolt and a nut?

Where should the locking device be placed in a bolt-and-nut joint?

How will you proceed in tightening several screws or bolts in a lid of a container?

10. Undoing Threaded Joints

– Bolts and screws which have grown rusty should be treated with a suitable rust solvent, to loosen them.

– Bolts and screws which cannot be loosened despite the use of a rust solvent must be bored out. Bore when you have removed the head and the nut with a chisel.

– Where component parts are to be taken apart, all screwed joints should be loosened before

the parts are fully dismantled.

– Use a suitable support for large parts which are to be dismantled so that they cannot drop onto the ground. Put the support in place before you unscrew the joints.

– Make sure that you remember the correct mounting position of parts which were removed for repairs.

Mark the parts suitably for re-assembly.

Use the right size of tools for disassembly work.

Beware that bolt threads or nuts are not damaged or you slip and cause injuries.

Give important details of dismantling component parts.

What general requirements must be met by assembly tools?
