

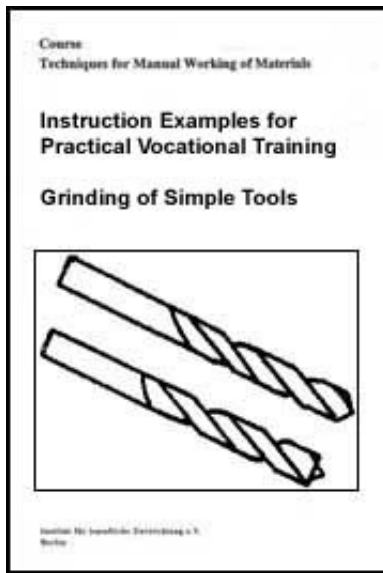

[Home](#) > [ar.cn.de.en.es.fr.id.it.ph.po.ru.sw](#)



 **Grinding of Simple Tools - Course: Technique for manual working of materials. Instruction examples for practical vocational training (Institut für Berufliche Entwicklung, 23 p.)**

 **(introduction...)**

 **Introduction**

 **Instruction example 12.1. Centre punch and scribing punch**

 **Instruction example 12.2. Steel scriber**

 **Instruction example 12.3. Screw driver**

 **Instruction example 12.4. Flat chisel and cape chisel**

 **Instruction example 12.5. Drill with standard drill point as well as flat drill point and centre point**



[Home](#) > [ar.cn.de.en.es.fr.id.it.ph.po.ru.sw](#)

 **Grinding of Simple Tools - Course: Technique for manual working of materials. Instruction examples for practical vocational training (Institut für Berufliche Entwicklung, 23 p.)**

 **(introduction...)**

 **Introduction**



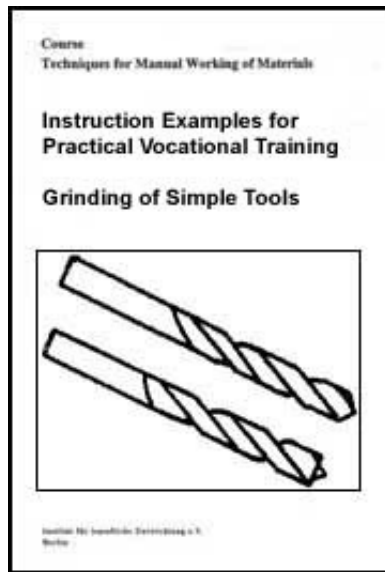

Instruction example 12.1. Centre punch and scribing



punch **Instruction example 12.2. Steel scriber**



Instruction example 12.3. Screw driver



Instruction example 12.4. Flat chisel and cape chisel



Instruction example 12.5. Drill with standard drill point as well as flat drill point and centre point

**Institut für berufliche Entwicklung e.V.
Berlin**

Original title:

**Lehrbeispiele für die berufspraktische Ausbildung
"Schrägen einfacher Werkzeuge"**

Author: B. Zierenberg

First edition © IBE

**Institut für berufliche Entwicklung e.V.
Parkstraße 23
13187 Berlin**

Order No.: 90-33-3112/2



[Home](#) > [ar](#).[cn](#).[de](#).[en](#).[es](#).[fr](#).[id](#).[it](#).[ph](#).[po](#).[ru](#).[sw](#)

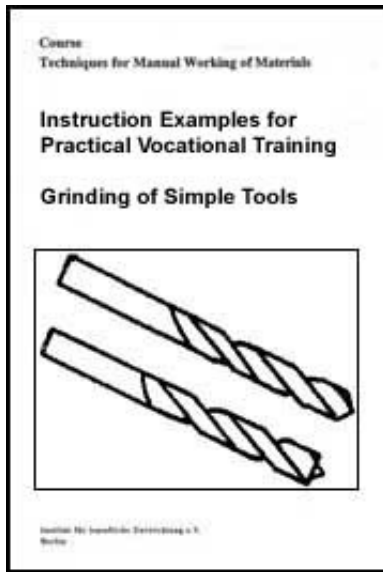

 **Grinding of Simple Tools - Course: Technique for manual working of materials. Instruction examples for practical vocational training (Institut für Berufliche Entwicklung, 23 p.)**

 **(introduction...)**

 **➔ Introduction**

 **Instruction example 12.1. Centre punch and scribing punch**

 **Instruction example 12.2. Steel scriber**

 **Instruction example 12.3. Screw driver**

 **Instruction example 12.4. Flat chisel and cape chisel**

 **Instruction example 12.5. Drill with standard drill point as well as flat drill point and centre point**

Introduction

The present documentation comprise 5 selected instruction examples with additional versions by means of which the grinding of tools can be exercised.

The exercises should be carried out, on principle, on worn-out original tools, but

possibilities for substituting such tools are mentioned as well if original tools are not available.

To facilitate the preparation and execution of the work, the materials, working tools, measuring and testing tools as well as accessories required for each instruction example are given. Moreover, the previous knowledge is mentioned which is necessary for the individual exercises.

On the basis of the working drawings enclosed and the appertaining sequences of operations the exercise pieces can be manufactured or worked.

Explanations to the working drawings:

The hardness of the tools is given to the hardness test with the Rockwell symbol "HRC" in connection with the unit of Rockwell. Marking of the characteristic pattern of the ground surface is shown on the working drawing in a circular detail representation.







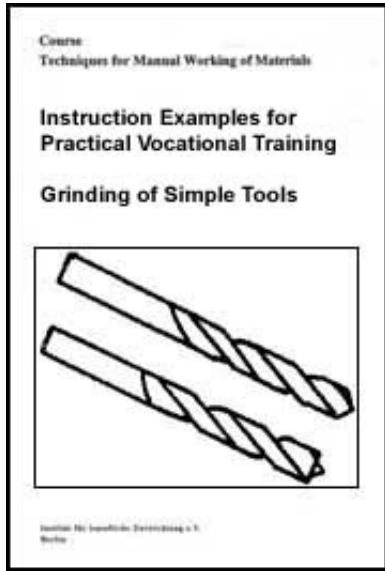

[Home](#) > [ar](#).[cn](#).[de](#).[en](#).[es](#).[fr](#).[id](#).[it](#).[ph](#).[po](#).[ru](#).[sw](#)

 **Grinding of Simple Tools - Course: Technique for manual working of materials. Instruction examples for practical vocational training (Institut fr Berufliche Entwicklung, 23 p.)**

 ***(introduction...)***



- ➔  **Introduction**
-  **Instruction example 12.1. Centre punch and scribing punch**
-  **Instruction example 12.2. Steel scriber**
-  **Instruction example 12.3. Screw driver**
-  **Instruction example 12.4. Flat chisel and cape chisel**
-  **Instruction example 12.5. Drill with standard drill point as well as flat drill point and centre point**

Instruction example 12.1. Centre punch and scribing punch

Exercising of sharpening of punches

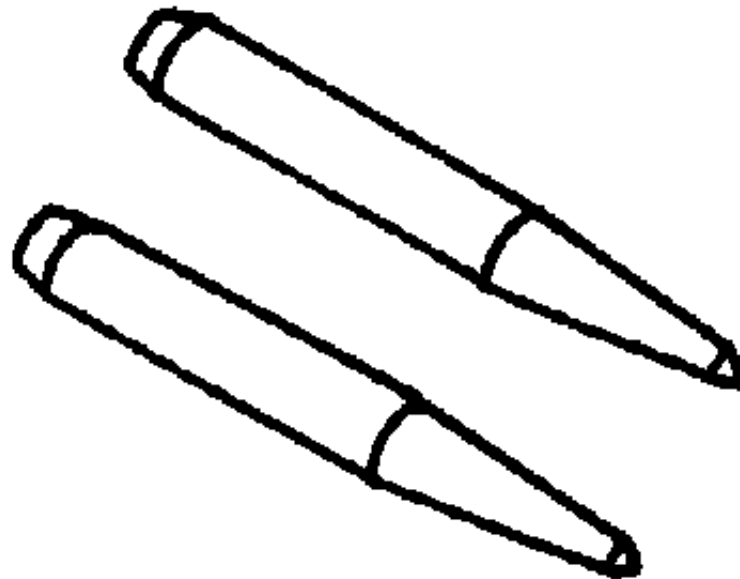

Figure

Material

- **Worn punches or**
- **Round material of silver steel:**

(carbon content 1.1. to 1.25 %)

Diameter: 10 mm

Length: 122 mm

Working Tools

Hand hacksaw

Measuring and testing tools

Vernier caliper, grinding gage or protractor

Accessories

Coolant (water)

Required previous knowledge

Reading of the drawings, measuring, testing, scribing, prick-punching, (sawing - when producing the punches)

Sequence of operations

Comments

1. Arrange workplace
prepare working material - Check for completeness
2. Sawing of the round
material to length - only if a original tool is not available!
3. Face grinding of one
face - Press workpiece in vertical direction against the wheel, turn it slowly around its axis
4. Grinding of a 4 mm
chamfer on this face -
horizontal or vertical
position - Press workpiece against the wheel with a setting angle of 45° , in doing so, turn is speedily and uniformly around its axis
5. Grinding of a 50 mm
long taper, proceeding
from the other face-
horizontal position - The right hand guides the workpiece, the left forefinger lies between the workpiece and the grinding support - press workpiece in horizontal direction against the wheel, turn is speedily as well as push it forward and back
6. Grinding of the point -
vertical position! - Press against the wheel only slightly with quick turning of it around its axis -risk of drawing the temper!
(1) - Centre punch 60°

(2) - Scribing punch 40°

7. Final check - Angle, accuracy to sice grinding pattern (as per drawing)

Completion:

Have the point hardened to HRC 50

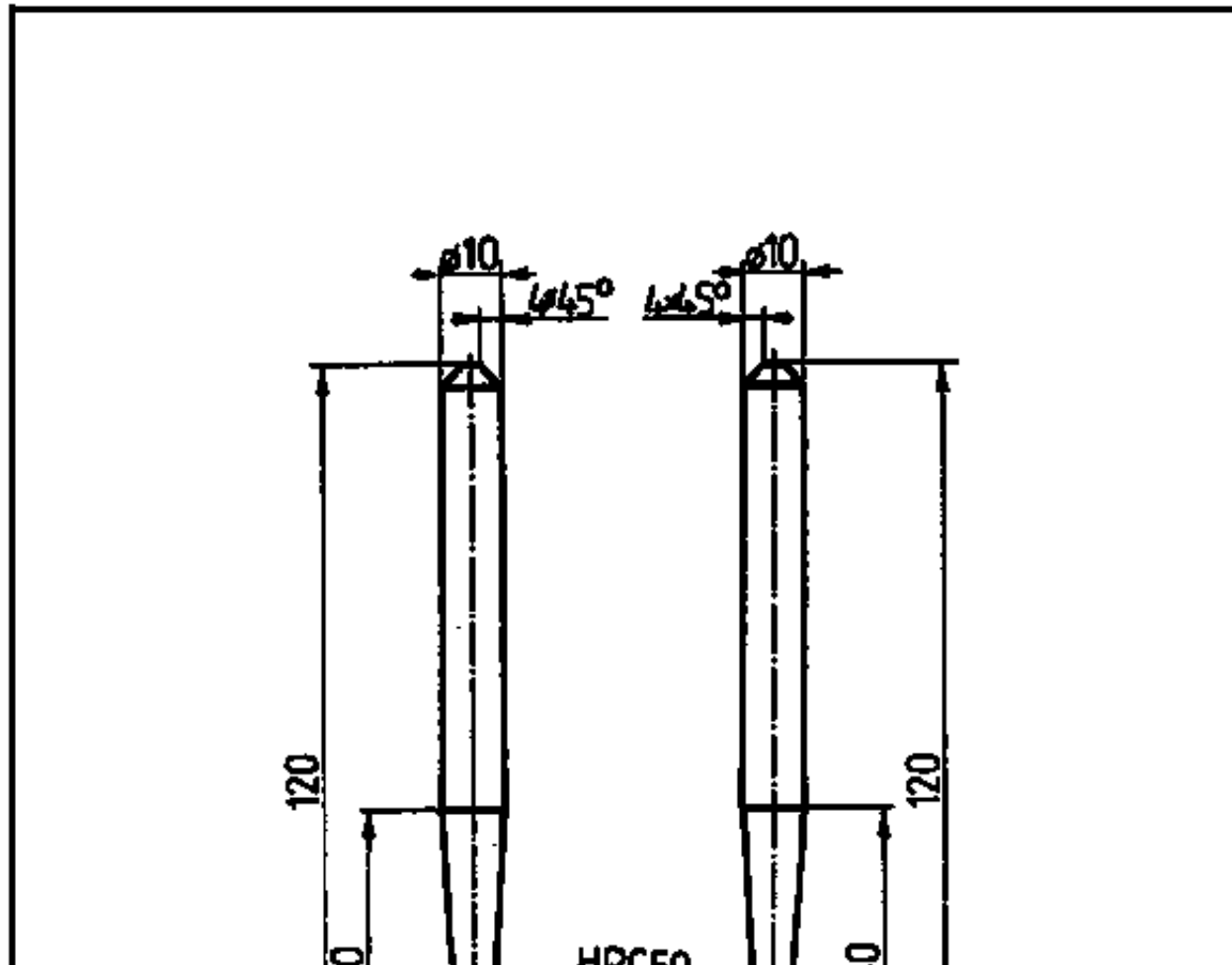

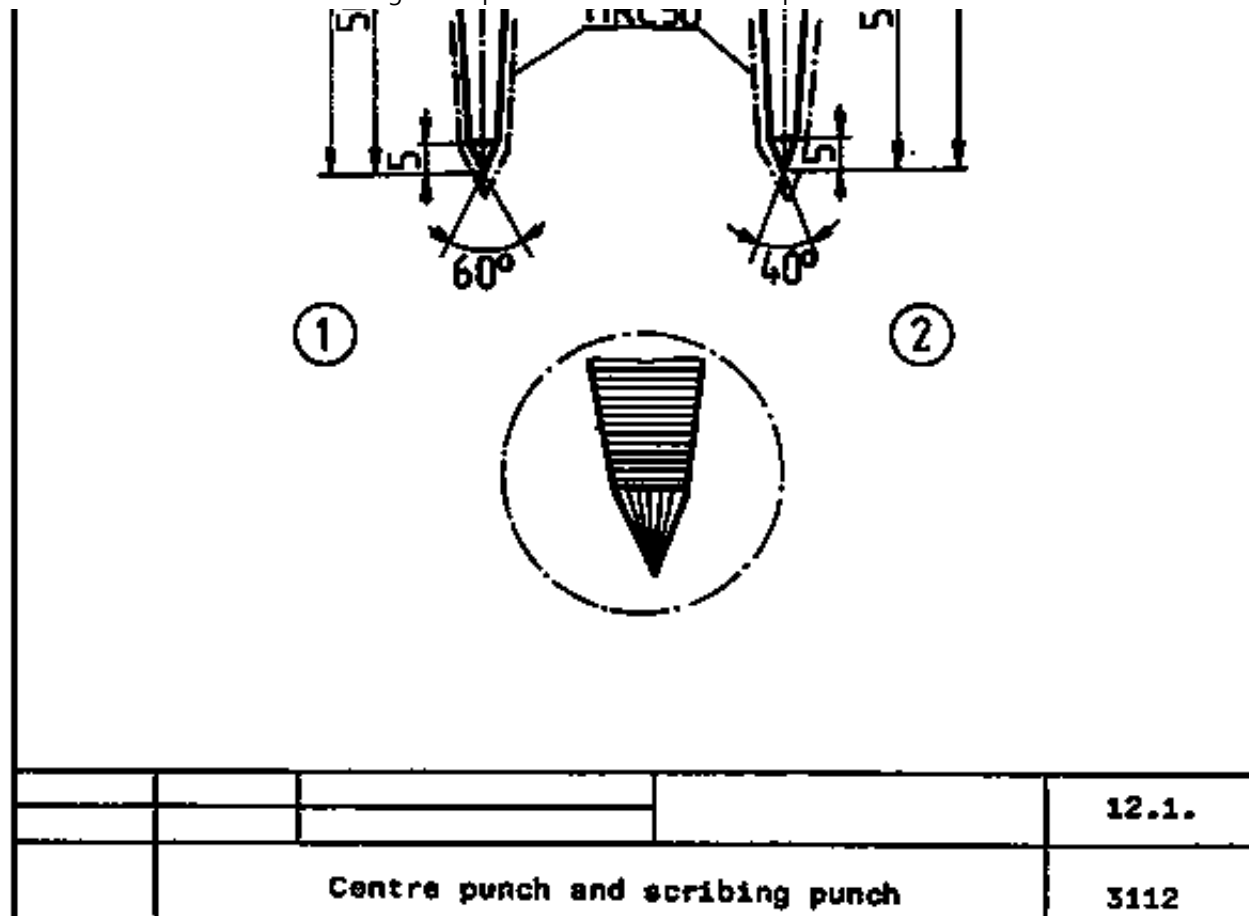

Centre punch and scribing punch



[Home](#) > [ar](#).[cn](#).[de](#).[en](#).[es](#).[fr](#).[id](#).[it](#).[ph](#).[po](#).[ru](#).[sw](#)

 **Grinding of Simple Tools - Course: Technique for manual working of materials. Instruction examples for practical vocational training (Institut fr Berufliche Entwicklung, 23 p.)**

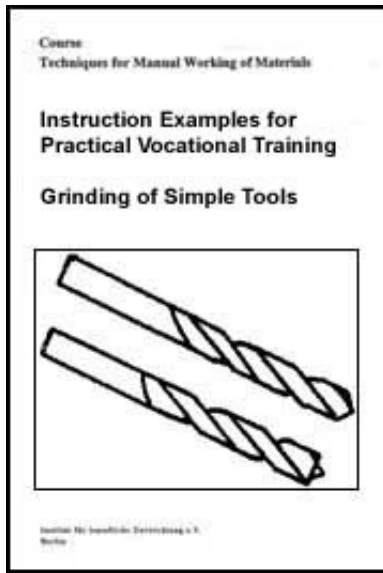

 **(introduction...)**

 **Introduction**

 **Instruction example 12.1. Centre punch and scribing punch**

 **→ Instruction example 12.2. Steel scriber**

 **Instruction example 12.3. Screw driver**

 **Instruction example 12.4. Flat chisel and cape chisel**

 **Instruction example 12.5. Drill with standard drill point as well as flat drill point and centre point**

Instruction example 12.2. Steel scriber

Exercising of the sharpening of steel scribers

Material

- **Worn steel scriber or**

- **Round material of silver steel:**

(carbon content 1.1 to 1.25 %)

Diameter: 4 mm

Length: 150 mm

- **Hexagonals of standard steel (380 MPa)**

width across flats: 10 mm

Length: 78 mm

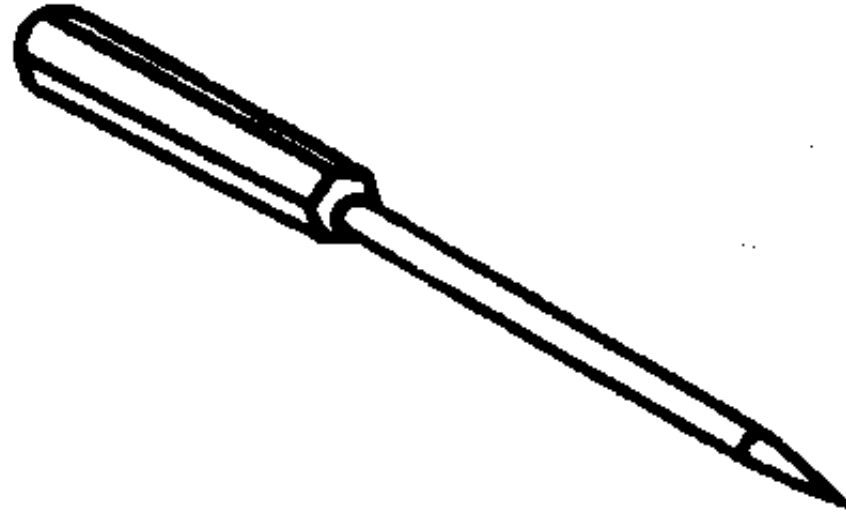

Figure

Working Tools

Hand hacksaw, drill 3.3 mm dia.; tap and threading die M4

Measuring and testing tools

Vernier caliper

Accessories

Coolant (water), cutting oil, tap wrench

Required previous knowledge

Reading of the drawings, measuring, testing, scribing, prick-punching, (sawing, drilling, countersinking/counterboring, threading - when manufacturing the steel scriber)

Sequence of operations

Comments

1. Arrange workplace prepare working material

- Check for completeness

2. Manufacturing of the individual components as per drawing

- Only if original tools are not available

3. Grinding of a chamfer of 4 mm at both sides of the handle - horizontal or vertical position!

- Press the workpiece against the wheel with a setting angle of 30°

4. Screwing of the scriber with the handle

- Firm joint!

5. Grinding of a 15 mm long taper on the scriber - horizontal position!

- Attention I Forefinger lies between the grinding support and the distance between the grinding support and the wheel, 2 mm max.!

6. Grinding of the point - vertical

- Turn quickly -cool much! Risk of drawing the

position!

temper

7. Final check

- Accuracy to size grinding pattern (as to drawing)

Completion: Have the point hardened to HRC 55

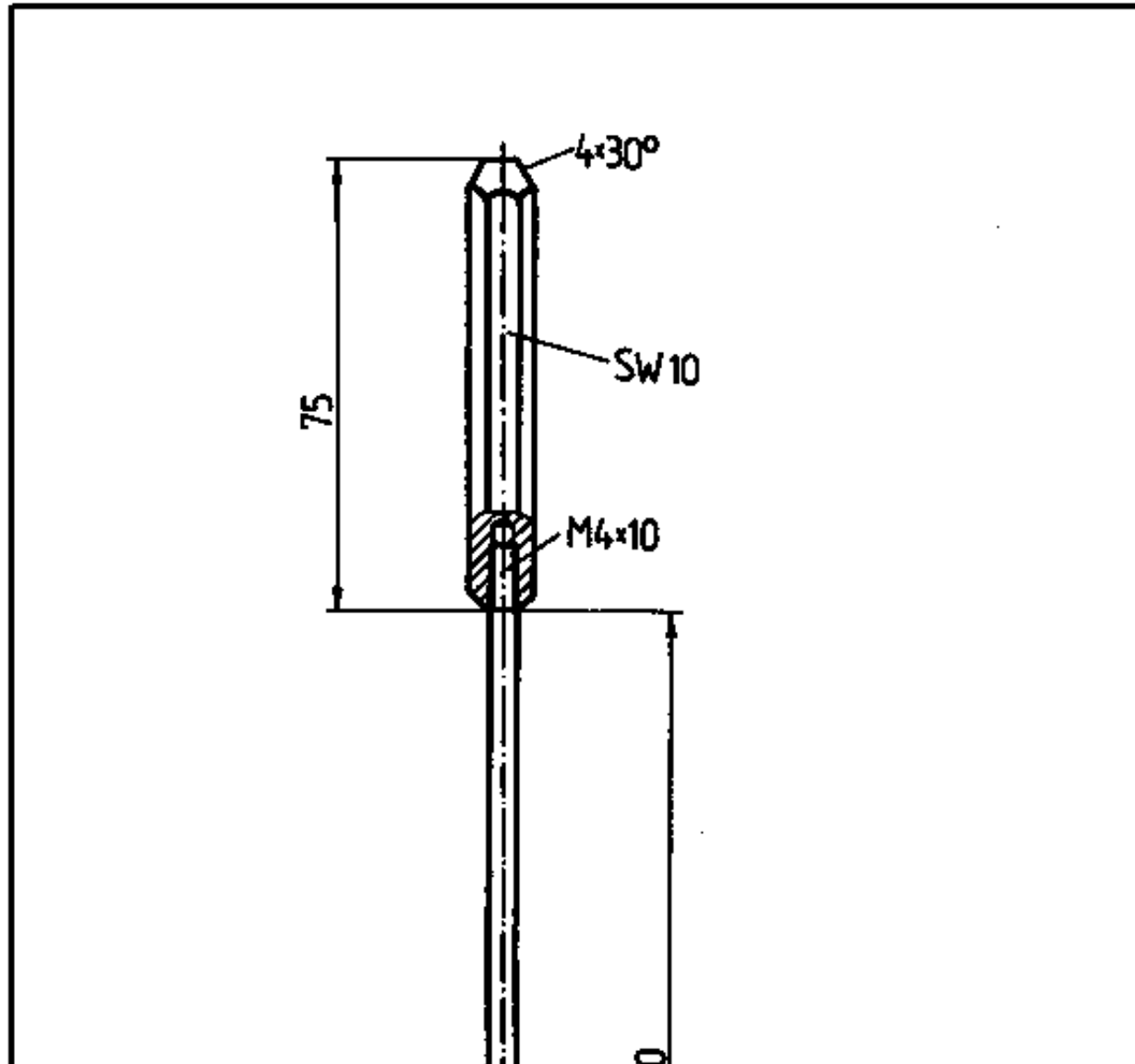

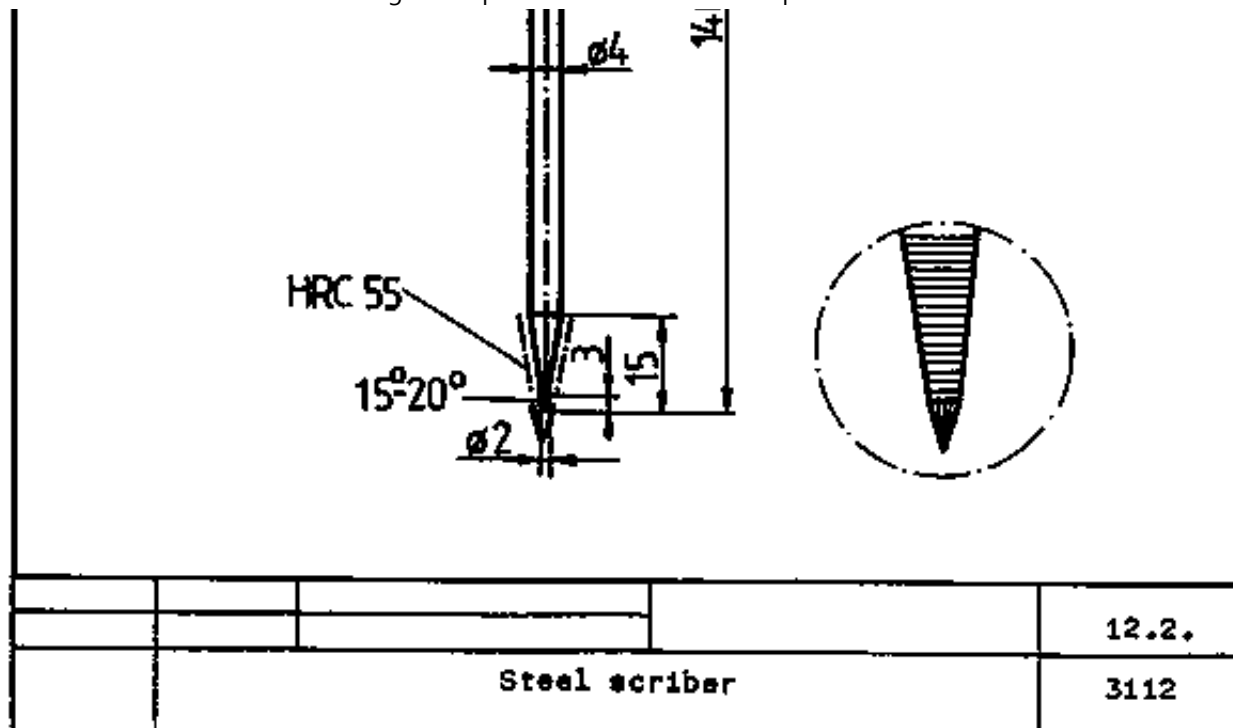

Steel scriber





[Home](#) > [ar.cn.de.en.es.fr.id.it.ph.po.ru.sw](#)

 **Grinding of Simple Tools - Course: Technique for manual working of materials. Instruction examples for practical vocational training (Institut fr Berufliche Entwicklung, 23 p.)**

 **(introduction...)**

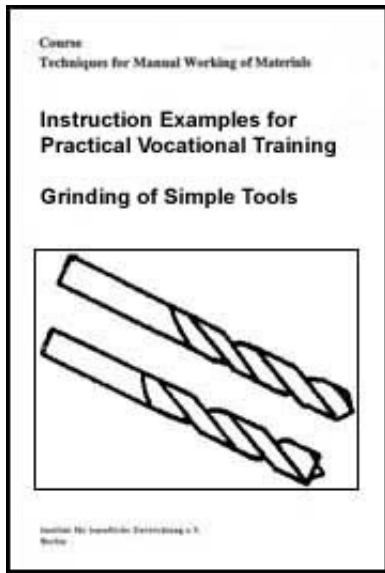
 **Introduction**



 **Instruction example 12.1. Centre punch and scribing punch**

 **Instruction example 12.2. Steel scriber**

 **Instruction example 12.3. Screw driver**

 **Instruction example 12.4. Flat chisel and cape chisel**

 **Instruction example 12.5. Drill with standard drill point as well as flat drill point and centre point**

Instruction example 12.3. Screw driver

Exercising of grinding of screw drivers

Material

- Worn screw drivers

or

- Round material of tool steel

(carbon content: 1 to 1.1 %)

Diameter: 5 mm

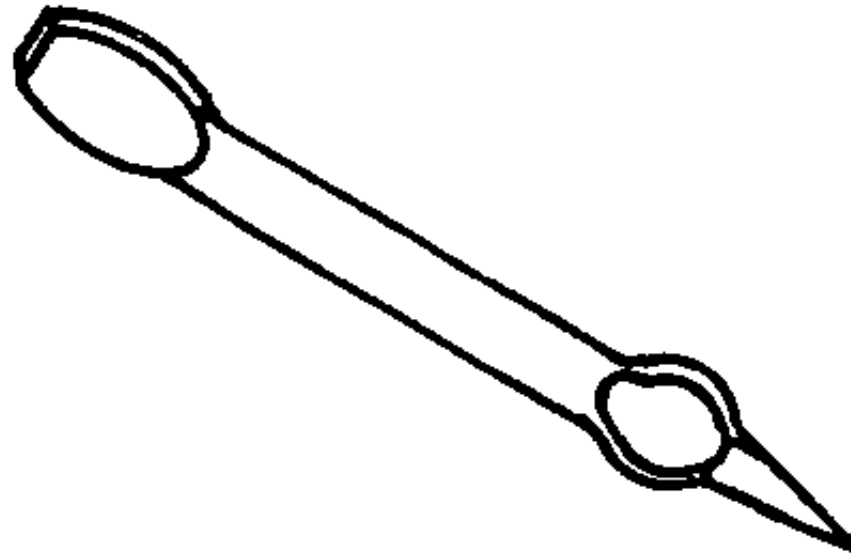

Figure

Working Tools

Hand hacksaw, engineer's hammer

Measuring and testing tools

Vernier caliper

Accessories

Surface plate, coolant (water)

Required previous knowledge

Reading of the drawings, measuring, testing, hammering

Sequence of operations**Comments**

- | | |
|--|---|
| 1. Arrange workplace prepare working material | - Check for completeness |
| 2. Sawing of the round material to length | - Only if original tools are not available |
| 3. Hammering of the screw driver blade (both sides) with the hammer face | - See to uniformity of the width!
Hammer no edges into the surface! |
| 4. Grinding of the screw driver blade in vertical position by placing it flat against the wheel and slightly pushing up and down | - Place the screw driver blade far above against the grinding wheel!
- Cool! |
| 5. Checking of the concaving and of the accuracy to size | |
| 6. Grinding of the tang in horizontal position | - Turn quickly! |
| 7. Final check | - Accuracy to size, grinding pattern (as to drawing) |

Completion:

Hardening of the blade to HRC 42

Hammering of the enlargement of the handle below the tang

Fixing of a wooden handle

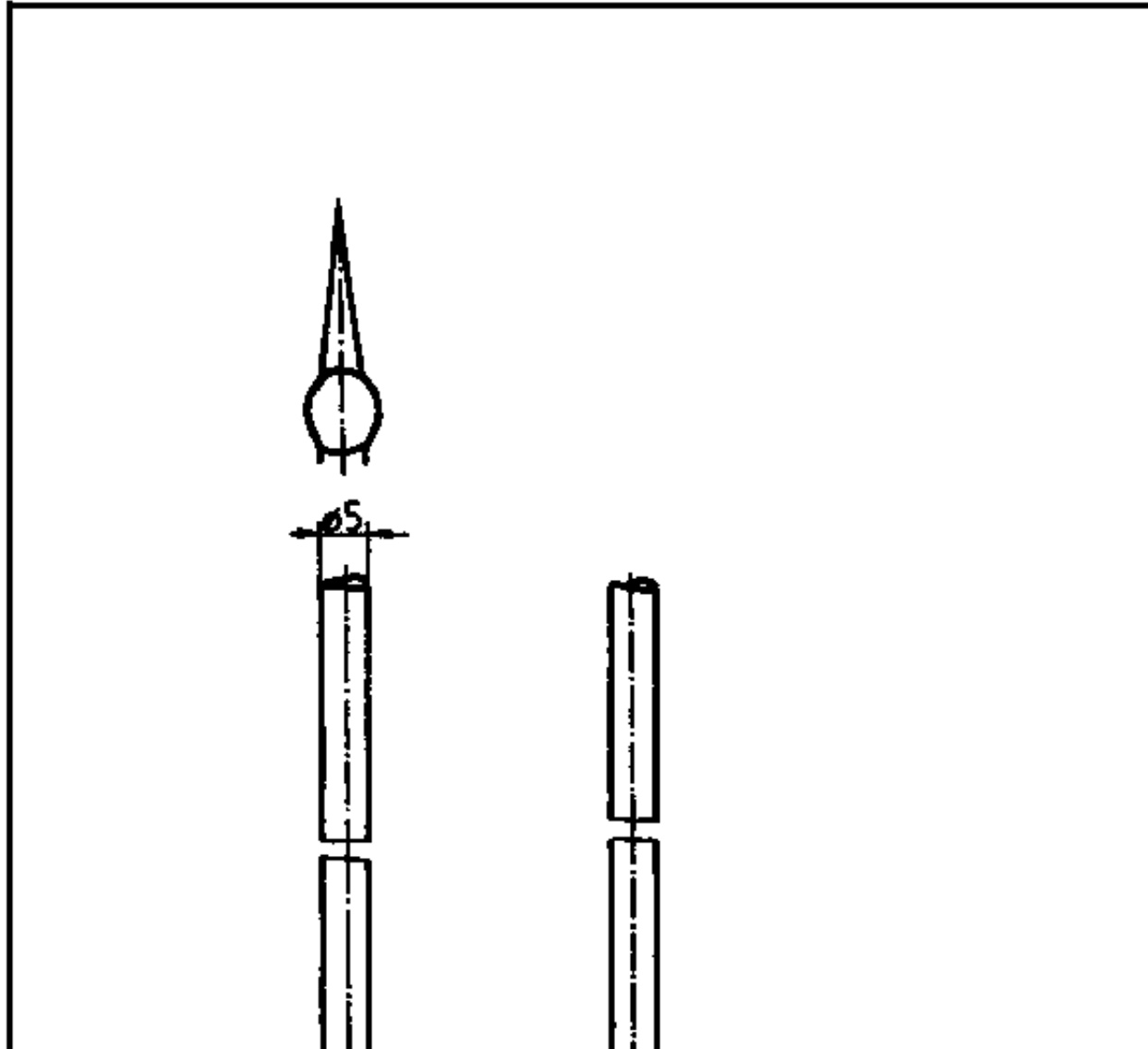

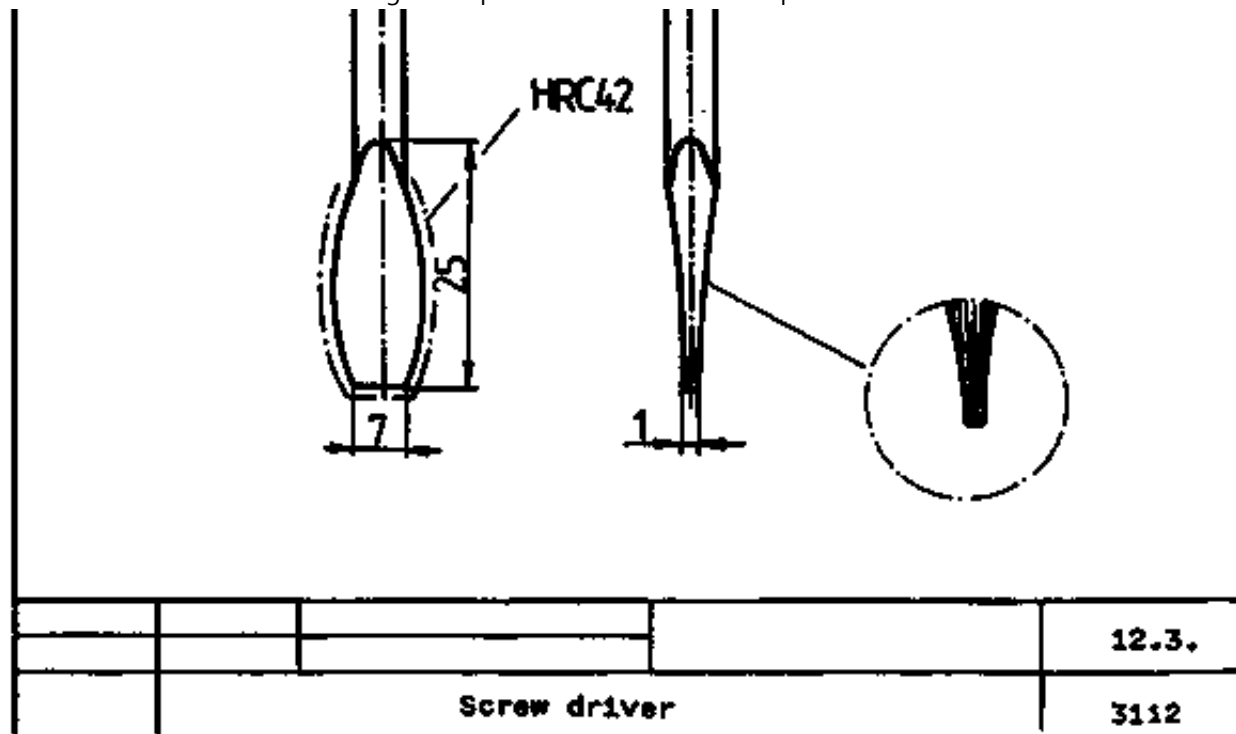

Screw driver



[Home](#) > [ar](#).[cn](#).[de](#).[en](#).[es](#).[fr](#).[id](#).[it](#).[ph](#).[po](#).[ru](#).[sw](#)

 **Grinding of Simple Tools - Course: Technique for manual working of materials. Instruction examples for practical vocational training (Institut fr Berufliche Entwicklung, 23 p.)**

 **(introduction...)**

 **Introduction**

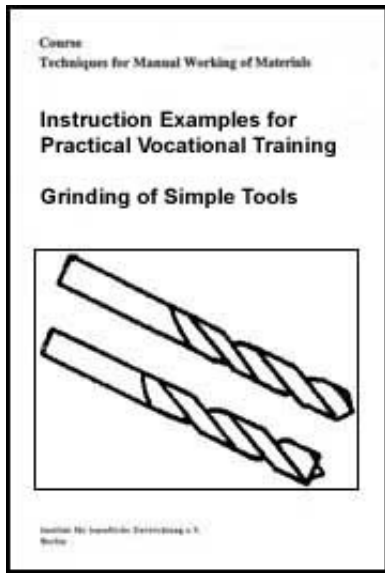

- 📄 **Instruction example 12.1. Centre punch and scribing punch**
- 📄 **Instruction example 12.2. Steel scriber**
- 📄 **Instruction example 12.3. Screw driver**
- ➔ 📄 **Instruction example 12.4. Flat chisel and cape chisel**
- 📄 **Instruction example 12.5. Drill with standard drill point as well as flat drill point and centre point**

Instruction example 12.4. Flat chisel and cape chisel

Exercising of sharpening of chisels

Material

- Worn flat or cape chisels

or

- Flat material of tool steel (carbon content: 1 to 1.1 %)

Thickness: 12 mm

Width: 20 mm

Length: 162 mm

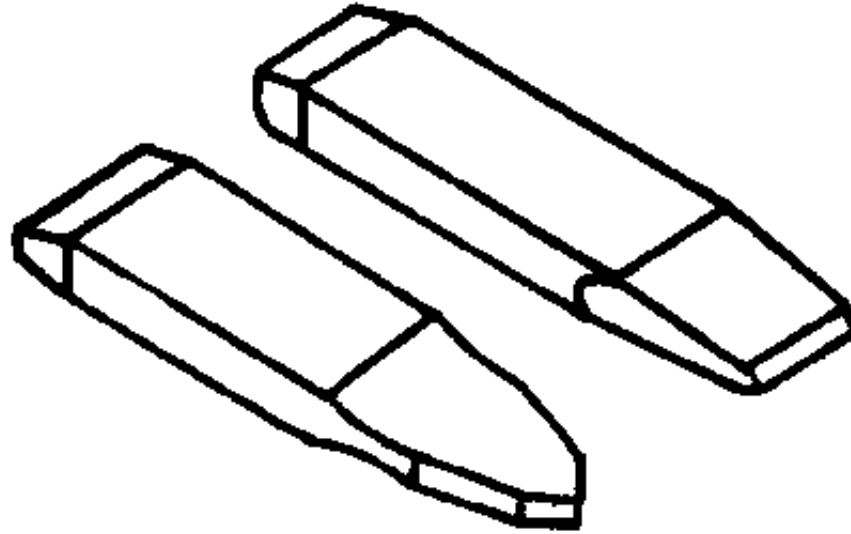

Figure

Working Tools

Hand hacksaw, steel scriber, whetstone

Measuring and testing tools

Steel rule, vernier caliper, grinding gage or protractor

Accessories

Vice, coolant (water)

Required previous knowledge

Reading of the drawings, measuring, testing, sawing, chiselling

Sequence of operations

Comments

Sequence of operations**Comments**

- | | |
|--|--|
| 1. Arrange workplace prepare working material | - Check for completeness |
| 2. Sawing of the flat material to length | - Only if original tools are not available |
| 3. Place the flat chisel (1) with its wide side horizontally against the wheel and uniformly move to and fro until the taper has reached a length of 60 mm | - Uniformly grind the taper by permanently changing the sides!
- Cool constantly! |
| 4. Grinding of the blades in vertical position by uniform pressure against as well as to-and fro movements | - Forefinger lies between the chisel and the grinding support! |
| 5. Checking of the surface of the taper as well as of the quality of the blades | - Surfaces to be smooth, blades to be sharp as well as parallel and angular to the outer edges |
| 6. Place the cape chisel (2) with its flanks horizontally against the wheel and grind (move to and fro) | - Permanently change the sides and cool! |
| 7. Place the blades in vertical position against the wheel and grind alternately by a short pressure against | - Attention!
Risk of drawing the temper - cool! |
| 8. Checking of the surfaces as well as of the quality of | - Same as for flat chisel |

8. Checking of the surfaces as well as of the quality of the blades - Same as for flat chisel
the blades

9. Clean whetting of the blades with the whetstone - Pull along the side of the blade
(removing of the burr)

10. Final check - Accuracy to size, appearance,
grinding pattern (as per drawing)

Completion: Have the blades hardened to HRC 48

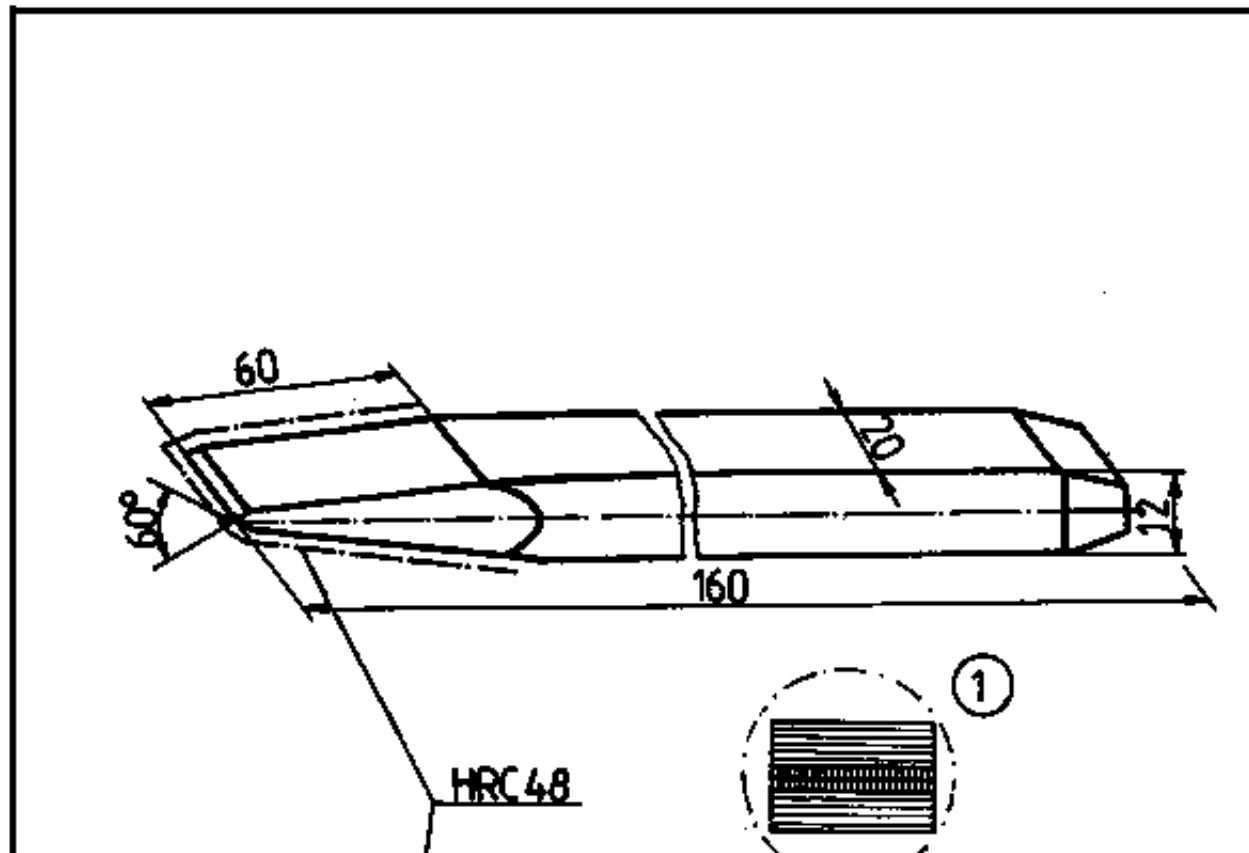

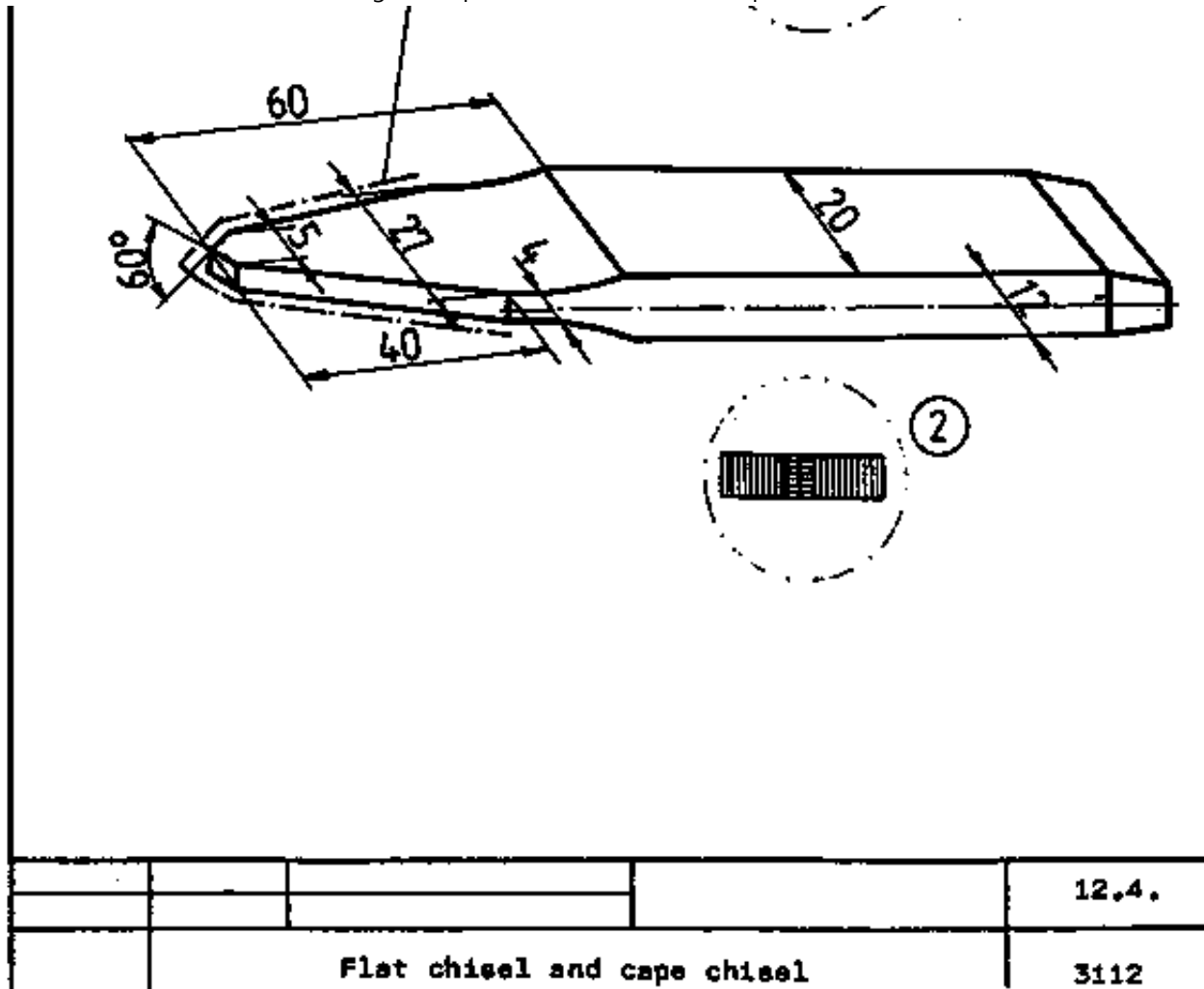

Flat chisel and cape chisel



[Home](#) > [ar](#).[cn](#).[de](#).[en](#).[es](#).[fr](#).[id](#).[it](#).[ph](#).[po](#).[ru](#).[sw](#)

 **Grinding of Simple Tools - Course: Technique for manual**

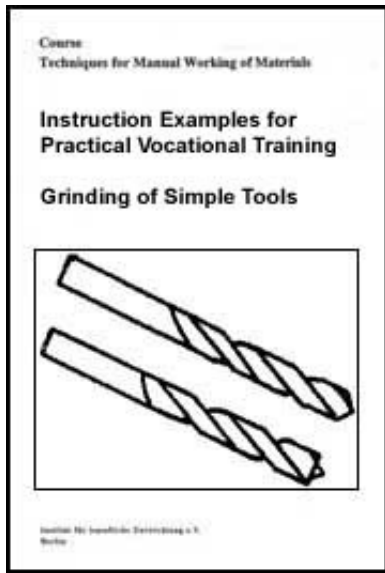

working of materials. Instruction examples for practical vocational training (Institut für Berufliche Entwicklung, 23 p.)

 **(introduction...)**

 **Introduction**

 **Instruction example 12.1. Centre punch and scribing punch**

 **Instruction example 12.2. Steel scriber**

 **Instruction example 12.3. Screw driver**

 **Instruction example 12.4. Flat chisel and cape chisel**

 **Instruction example 12.5. Drill with standard drill point as well as flat drill point and centre point**

Instruction example 12.5. Drill with standard drill point as well as flat drill point and centre point

Exercising of sharpening of drills in the most used types of drill point grinding

Material

worn-out drills

diameter: 4 to 12 mm

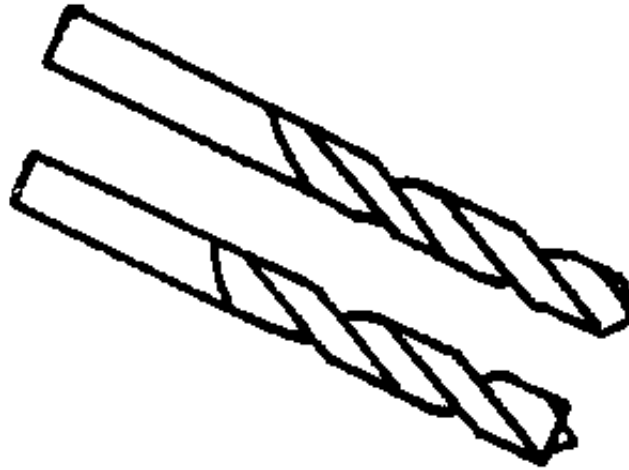

Figure

Working Tools

Measuring and testing tools

Grinding gage or protractor

Accessories

Coolant (water)

Required previous knowledge

Reading of the drawings, measuring, testing, drilling

Sequence of operations

1. Arrange workplace prepare working material

Comments

- Check for

2. Lay the drill with the standard drill point (1) between thumb and forefinger (left hand) and advance the drill with the right hand towards the grinding wheel so that the main cutting edge lies horizontally and the drill itself exactly horizontally. The setting angle is about 56° from the left-hand side

3. Press the drill slightly against the wheel and push it towards above and at the same time slightly to the right-hand side -at the top take it off

- Grind both cutting edges uniformly (alternately) - and cool!

4. Check for grinding faults as well as for adherence to the angles given

5. Take the drill with the flat drill point and centre point (2) as described above and press it with the main cutting edge exactly vertically against the horizontally lying grinding wheel, in doing so, the centre point must project at the right-hand grinding wheel edge!

6. Push the drill with a slight pressure in vertical direction towards above, at the top take it off

- Cool!
Grind uniformly at both sides!

7. The centre point is sharpened by lateral grinding at the right-hand grinding wheel edge

8. Checking for grinding faults

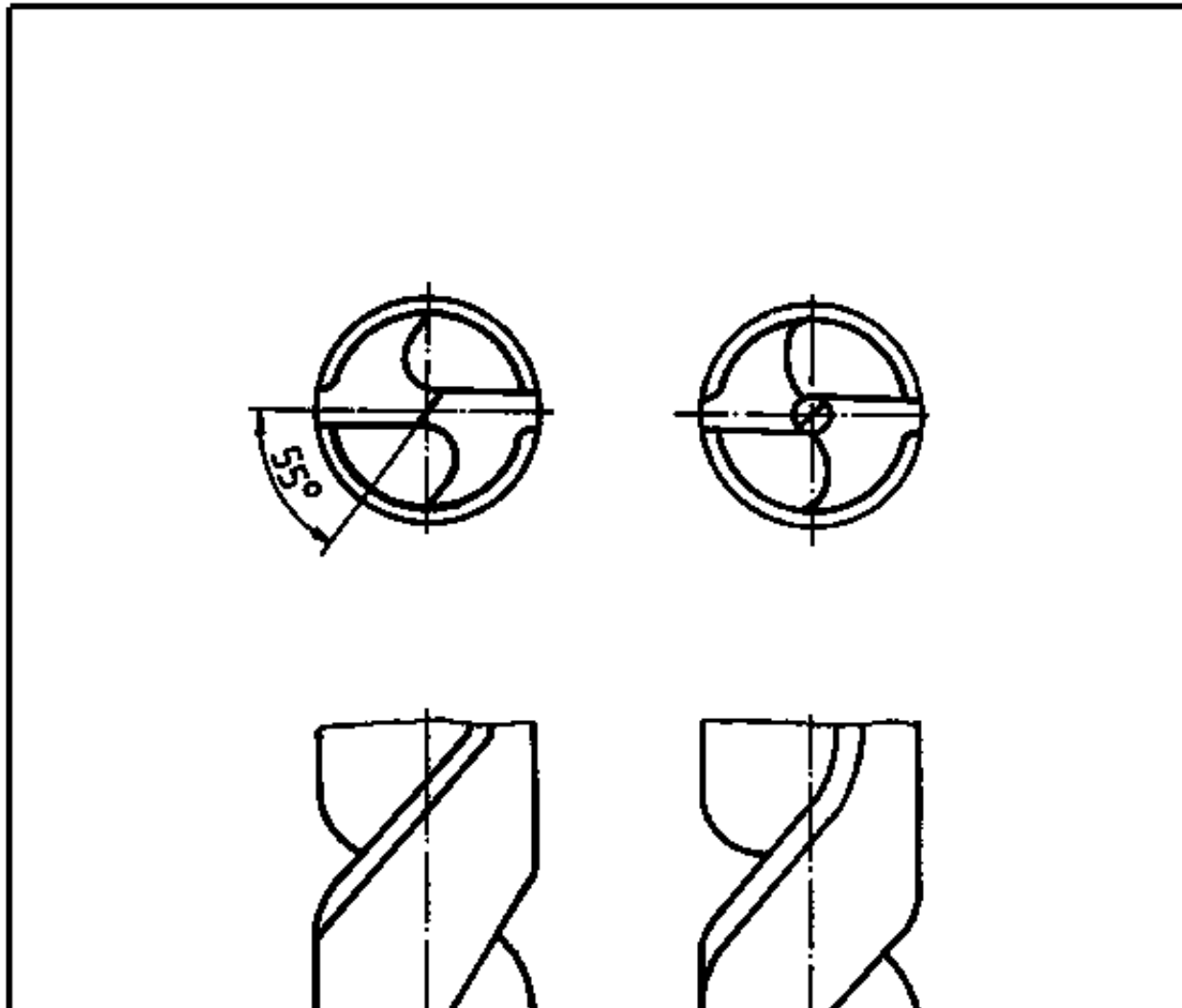

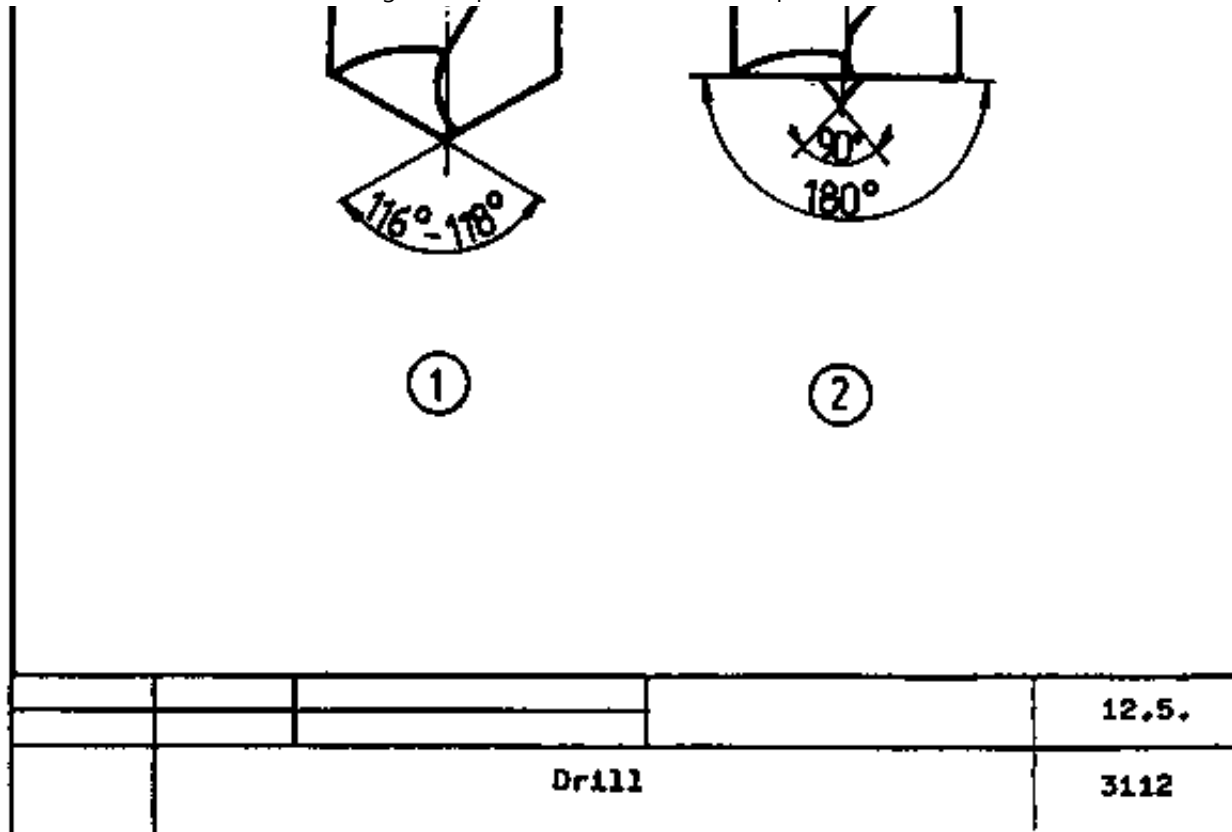

①

②

Drill

Drill

