

**Electric Welding 1 – Course: Techniques of Electric Welding.
Methodical Guide for Instructors**

Table of Contents

Electric Welding 1 – Course: Techniques of Electric Welding. Methodical Guide for Instructors	1
0. Preliminary Remarks.....	1
1. General Methodical–organisational Information.....	2
1.1. On the Arrangement of the Vocational Training.....	2
1.2. Practising.....	3
1.3. Control Evaluation and Interpretation.....	5
1.4. Information about the Maintenance of the Means of Work.....	6
2. Principle and Use of Electric Welding.....	7
3. Means of Work for Electric Welding.....	7
4. Terms of Electric Welding.....	8
5. General Labour Safety.....	12
6. Welding of Single Beads "g".....	13
6.1. Preparing the Exercise Plates.....	13
6.2. Welding of the Single Beads.....	14
7. Building–up Welding "g".....	20
7.1. Preparing the Exercise Plates.....	20
7.2. Welding a Surfacing Weld.....	21

Electric Welding 1 – Course: Techniques of Electric Welding. Methodical Guide for Instructors

CRYSTAL

Lehr- und Lernmittel,
Informationen, Beratung

Educational Aids
Literature, Consulting

Moyens didactiques,
Informations, Service-conseil

Material didáctico,
Informaciones, Asesoría

Feedback: IBE e.V.
90-32-0601/2



Deutsche Gesellschaft für
Technische Zusammenarbeit (GTZ) GmbH

Institut für berufliche Entwicklung e.V.
Berlin

Original title:
"E-Schweißen 1"

Author: Dietmar Mühs

First edition © IBE

Institut für berufliche Entwicklung e.V.
Parkstraße 23
13187 Berlin

Order No.: 90-32-0601/2

0. Preliminary Remarks

The present Methodical Instructions are intended for the instructor; they will give him help and assistance in the preparation and realisation of vocational training. They directly apply to the instructor – frequently addressing him personally – submitting suggestions and pointing out focal points for imparting knowledge and skills. For this purpose, pedagogic–didactic ways of solution are proposed. They enable the realisation of the aim of training specified in the course of instruction by the pedagogic activities of the instructor. The Instructions are arranged in such a way that the trainees are in a position to acquire the knowledge, abilities and skills required for electric welding.

Particular attention has been paid to the principle to proceed from the simple to the complicated subjects. The sequence of the individual welding positions, the grasping and practising of them, is based on experiences in the training of electric welders gathered during many years.

During training, the trainees

- have to learn how to handle the pieces of equipment and tools.
- have to practise the execution of the various welding positions.
- must be able to coordinate the welding positions with the various applications.

After conclusion of training, the trainees must be in a position

- to judge the quality of the results of their work, identify faults and their causes and remove them.
- to handle and operate the means of work and subjects of labour entrusted to them economically.

Recommendations for and information about the educational work – of the instructors within the scope of the tactical vocational training are incorporated into the Methodical Instructions. After conclusion of the course of training, the trainees shall possess such character attributes and such a behaviour as:

- conscious discipline during the working processes,
- conduct in accordance with labour safety,
- collective and companionable behaviour,
- self-critical assessment of the own work (welding work is a matter of conscience).

The Methodical Instructions should not be considered regulations which are rigid and have to be observed strictly. The users of them have full scope to realize their own ideas.

1. General Methodical–organisational Information

1.1. On the Arrangement of the Vocational Training

In the planning and realisation of vocational training, one has to start from the fact that it is a purposive process at the end of which there is a predetermined, exactly defined and duly evidenced qualification.

This means that complete command of vocational knowledge, abilities and skills, hence,

- the learning,
- the practising,
- the exercising,
- the acquisition of operations, motions, control algorithms for electric welding are the centre of training.

This shows that practical vocational training is a planned, purposive, didactically and methodically prepared process, and it should be arranged accordingly.

The aim of the training consists in the lasting acquisition of knowledge, abilities and skills, in the education of consciously acting personalities. This calls for the use of approved pedagogic, didactic and methodical findings and laws. These findings have been integrated into the Methodical Instructions.

The basic unit for the practical vocational training in electric welding is the job of the trainee, his task as an apprentice or worker.

This task is associated with the equipment for the electric weldor. The curriculum for the practical vocational training of the electric weldor contains, among other things, the learning of the welding positions.

The individual welding positions are self-contained training sections.

At the end of any training section, a practice workpiece or examination workpiece must be welded.

In the directions for examination, the examination pieces required for the weldor's qualification under consideration are mentioned.

Consequently, the various methodical instructions must be compiled in accordance with the aim of the training.

In the practical training, particular attention must be paid to the control and evaluation of the results of work. In this respect, the explanations given in the Section "Control, evaluation and interpretation" have to be observed.

The Methodical Instructions are based on the consideration that the practical vocational training takes place in a training workshop. Training in production is not possible in this case because in vocational training it is only allowed to weld exercise pieces until the final examination.

An important precondition for good performances in practical vocational training are long-term planning and well-devised organisation of training.

It should be noted that maximum two trainees are in the welding booth.

One instructor should be in charge of the simultaneous training of 8 trainees.

He must thoroughly analyse the stage of training or given qualification of the trainees and organise the further training course accordingly.

The sequence of learning the welding positions (methodical instructions) should not be dogmatised. It is quite possible to change the sequence, taking the level of achievement and progress in learning of the trainees into consideration. Basis of planning the practical vocational training is the day of instruction. For such a day of instruction, the trainees can be given the following tasks:

1. acquisition of new knowledge and abilities
2. practising, exercising, acquisition of skills

Especially the skills of electric welding can only be acquired by repeated practising and exercising the electrode position in the various welding positions. Therefore, particular attention should be paid to practising. In this connection, the instructions given in Section "Practising" must be observed in any case.

1.2. Practising

Before the trainees start practising, give them the following information:

- which target or sub-targets have to be achieved,
- which labour safety, health protection and fire protection regulations have to be observed in particular,
- how to proceed (arrangement of operations and special tasks).

After having given this information, ask the trainees to arrange their working places for the operations to be acquired. Show the trainees a properly arranged working place.

Explain the operations to be performed in full detail:

- characteristic of the results of the operations to be carried out (acquisition of the welding position in question)
- condition of the finished subject of labour (peculiarities of the workpiece)
- properties of the material or semi-finished product to be tooled and welded
- explanation of the basic and auxiliary operations which are required for the job to be performed (setting the current intensity, change of the electrodes, etc.)
- handing over the material

- discussing the forms of control and self–control.

Then you must demonstrate the operations of the means of work and show the necessary manipulations and actions of work.

Demonstration is an important criteria of the educational and training activities of the instructor.

At the end of any particular instruction, demonstration must be effected as a foundation of training.

Only when the work to be done or the job, its demonstration and the repetition by one trainee has been understood by all other trainees, you should ask the trainees to perform the work.

For this purpose, allow an adequate number of exercises.

Further, ask the trainees to take advantage of the knowledge, abilities and skills which they have already acquired.

The practical activity of the trainee, the practising and exercising, plays an important role in the training for the acquisition of practical vocational knowledge, abilities and skills.

For practising, you should take into account the following criteria:

- Practising serves for the development, perfection and consolidation of abilities and skills.
- Practising should be based on an increasing degree of difficulty.
- Practising should be organised in such a way that the trainees perform their work readily and joyously and that they are interested in a comparison of their achievements.
- In practising, the trainees should be assisted individually, and the progress in learning should be recorded in surveys of the results obtained.
- Impartation of the subject–matter should be continued only when all trainees have understood the preceding subjects.
- Practising should be supplemented by rules.
- In all practising sections, information should be given about the maintenance of the working tools and equipment and about labour safety.

You should bear in mind that a consistent training always proceeds from the simple to the complicated subjects.

Now, allow the trainees to start their work and to practise the operations involved.

In this process, you should aid the trainees and correct their errors.

If, in a exercise, typical errors are repeated by the trainees, analyse and discuss them with the trainees in order to avoid repetition of these errors.

Familiarise the trainees with rules regarding special technical subjects.

During practising, record the performances and results of learning achieved by the trainees and take care that the labour safety regulations are strictly observed.

Carry out intermediate controls by means of which you are also in a position to find out the productive application of the things learned.

In conclusion of the practising section, carry out an achievement control. Observe the information given in Section "Control, Evaluation and Interpretation".

Analyse and discuss the achievements and results of learning obtained in the preceding section under consideration together with all trainees.

At the end of the training day, request the trainees to clear their working places and to clean the workshop.

All that has been said above shows that the continuous process of practical vocational training is very differentiated and makes great demands on the organisation and, thus, on the methodical skill and pedagogic activities of the instructor. Further, in the process of vocational training, you have to make up your mind as to how you intend to proceed in the impartation of the subject–matter or how you have to proceed in accordance with the given conditions.

A distinction is made between three organisational basic forms of practical vocational training:

1. individual instruction of the trainee (individual procedure)
2. instruction of groups (group procedure)
3. simultaneous instruction of all trainees (frontal procedure)

In any of these procedures, practising, consolidation and depending the knowledge, abilities and skills of the trainees is included under the direction and control of the instructor. The third form is unfavourable for the training of electric weldors. The group procedure plays an important part because the trainees receive the theoretical knowledge required for their practical work in this manner. During the practical work, the instructor guides the trainees individually.

1.3. Control Evaluation and Interpretation

Control, evaluation and interpretation are essential parts of the training process.

They follow the phase of instruction and realisation. Control, however, should already be a constituent part of these two training phases.

Therefore, pay particular attention to the strict observance of control, evaluation and interpretation. In this way, you will always be informed of the stage of the educational and training work achieved.

In particular, you will know at any time whether

- there are successes and deficiencies in your own planning and organisational efforts,
- direction and assistance of the trainees have been effected in the correct way,
- the specified targets have been reached by the trainees,
- the personality of the trainees has been developed.

During training, observe the following hints:

- when you go your rounds, you should obtain a general view of a great number of evaluation criteria and of the progress of work being done by the trainees.
- Check the process of training and give hints
 - on the performance of work,
 - on the effective arrangement of work,
 - on health and labour safety and fire protection, etc.
- Note down your findings for the comprehensive evaluation of the achievements of the trainees.

Take notes of observations necessary for the evaluation of the achievements of the trainees and enter this evaluation in files. When controlling and evaluating the achievements of the trainees, pay particular attention to the following items:

1. control and evaluation of the quality of work,
2. control and evaluation of the mode of work during working,

3. control and evaluation of order and cleanliness at the working place,
4. control and evaluation of how theoretical knowledge is applied in practice.

For an evaluation of their achievements of the trainees, proceed in the following order:

- 1st step: Definition of the achievement criteria on the basis of the selected and defined tasks.
- 2nd step: Definition of the methods for the acquisition of the achievement criteria.
- 3rd step: Coordination of the achievement criteria with the scale of marks.
- 4th step: Determination of the learning and working achievements of the trainees on the basis of the achievement criteria.
- 5th step: Comparison of the achievement criteria with the specifications of the scale marks in order to find an overall mark for every trainee (see Section on Direction for the Examination).
- 6th step: Notifying and discussing the report.

When you think that the trainees possess the required abilities for the performance of the welding position in question, have a practice sample stamped and welded under examination conditions.

Evaluate the stamped practice sample. Ask the trainees to propose the mark; this will educate to self-critical work. Determine the marks for accuracy to size, appearance of the seam and fracture appearance and the final mark according to the specified directions. Enter these marks in an evaluation sheet which is visible to all.

When a trainee fails to reach the required sub-target, then enter this fact into the evaluation sheet. Offer the possibility of making up for the missing knowledge.

The trainees must become aware of their level of achievement and develop purposive activities for the removal of still existing deficiencies. At the same time, the ability for self-assessment of the trainees is to be developed.

Assessment of the results:

For this purpose, it is necessary for you to find errors and deficiencies in training that you may have caused yourself. When you have found out that errors and deficiencies are not due to your own failure, you should trace the cause of them in the trainees or in other factors which might have, or actually have, exerted a negative influence on the process of training. Lay down measures for yourself which will prevent the same errors and deficiencies in further training courses.

Discuss these measures with other instructors and with the management of the training centre, thus, rendering mutual assistance for improving the educational and training results.

1.4. Information about the Maintenance of the Means of Work

Explain to the trainees the importance of the maintenance of the means of work. In this connection, enter into particulars on the following important items:

- means of work which are in a proper condition are an essential precondition for welding the subjects of labour according to the rules of good workmanship (e.g. electrode holder).
- means of work which are subjected to routine maintenance remain serviceable for a prolonged period of time.

Pay attention to the fact that the trainees strictly observe the instructions and requirements given by you as to the maintenance of the means of work in order that their serviceability is warranted. Fall back upon the rules

for care and maintenance of the means of work which are already known to the trainees.

Further, bear in mind:

- correctly employed means of work remain serviceable for a prolonged period of time

When controlling the trainees at work, ask them to show you their means of work and single out damaged means of work! Train the trainees to keep their means of work properly and safety!

Allow the trainees to restore their means of work to proper condition provided this is necessary and permissible from the angle of labour safety!

Impart to the trainees the manual skill and abilities necessary for this purpose!

Explain to the trainees which means of work must not be repaired by them!

Impart to the trainees the necessary knowledge so that they are in a position to find out when a means of work has to be repaired or replaced by a new one!

Train the trainees to become responsible workers who replace defective means of work which are no longer serviceable!

Again and again fall back upon the knowledge already acquired by the trainees and see to it that it is practically used.

Pay particular attention to the economic aspects (prime cost of a means of work – repaired means of work).

Avail yourself of the possibility of breeding pride in the trade into the trainees.

A good expert worker is recognised by his means of work which are in proper condition!
--

2. Principle and Use of Electric Welding

Experience has shown that the urge for knowledge is great at the beginning of a new subject–matter. In order to interest the trainees in electric welding, it is necessary to demonstrate the process of electric welding. For this purpose, station the trainees about the welding table, give each of them a weldor's screen and ask them to hold it in front of their faces. Point out that all of them hold the screen in front of their faces and observe your demonstration. Demonstrate the welding of a single bead in gravity position.

Subsequently, explain the principle of electric welding. For this purpose, use the textbook "Welding of Steel".

Order the trainees to read the literature carefully and to prepare a repetition of the principle of electric welding in the form of a paper to be read.

Evaluate this paper and add missing items. Then explain the different fields of application of electric welding. For illustration, show welded workpieces. Ask the trainees to tell you applications of the method of electric welding.

3. Means of Work for Electric Welding

Advise the trainees that wearing apparel which complies with the labour safety regulations is of particular importance to an electric weldor. When preparing this Section, keep this clothing in readiness. Pay attention to the fact that all trainees have such a weldor's clothing at their disposal.

- weldor's screen
- weldor's gloves (gauntlet–type leather gloves)
- working shoes
- headgear

- weldor's protective clothing or leather apron

Explain the function of the various parts of clothing. Enter into particulars on the weldor's protective screen.

In this connection, point out to the trainees that they should not approach the welding spot too closely in order that the glasses will not become too hot and burst.

Then ask the trainees to put on their wearing apparels. At the end of this Section, one trainee shall repeat the parts of the wearing apparel and their functions. If necessary, supplement him.

Subsequently, show the trainees the means of work of an electric weldor. Make sure of the knowledge present from theoretical lessons. At first, explain the pieces of equipment required for welding.

- welding converter
- electrode holder (negative pole) and electrodes
- lines
- clamp for workpiece (positive pole)
- welding table
- deslagging hammer
- wire brush

Explain the function of the individual pieces of equipment. In this connection, allow the trainees to exercise the inserting of the electrodes into the holder and the putting into operation of the welding equipment.

Show the trainees the main switch of the installation and the installation for adjusting the current intensity, Tell the trainees different current values and ask them to adjust these values. Check the setting of these values. Find a connection to theoretical lessons (negative pole; positive pole). As a conclusion of this sub-section, summarise the pieces of equipment. Then quote one piece of equipment at a time and ask one trainee to show it and explain its function, then ask the next trainee to show and explain the next piece of equipment and so on.

4. Terms of Electric Welding

Train the trainees to use the established expressions and terms. In this way you will facilitate the explanation of the processes and the giving of job orders and the mutual communication.

Give some detailed explanations.

Terms:

- effects of electrical current
- thermal effect and luminous effect
- magnetic effect
- chemical effect

Show the magnetic effect with the help of the following demonstration. A cardboard disk is slipped on a welding electrode. Iron filings are strewn on the disk. The electrode is short – circuit–ed. Use Fig. for your explanations.

- types of electrical current
 - direct current
 - alternating current
- blow effect

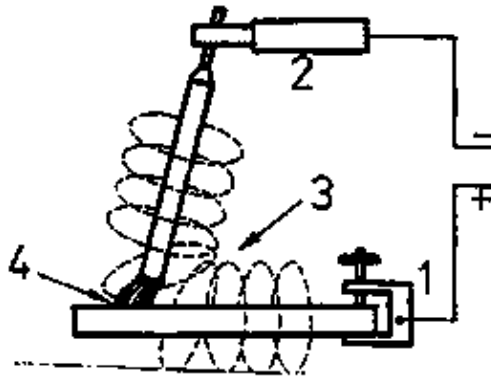

- 1 positive pole (earth clamp - workpiece)
- 2 negative pole (electrode)
- 3 lines of magnetic field
- 4 deflected arc

Fig. 1 Magnetic field about electrode and workpiece

When explaining the arc blow effect, enter into particulars on the corrective measures because the blow effects renders the production of proper weld seams impossible.

- welding current intensity

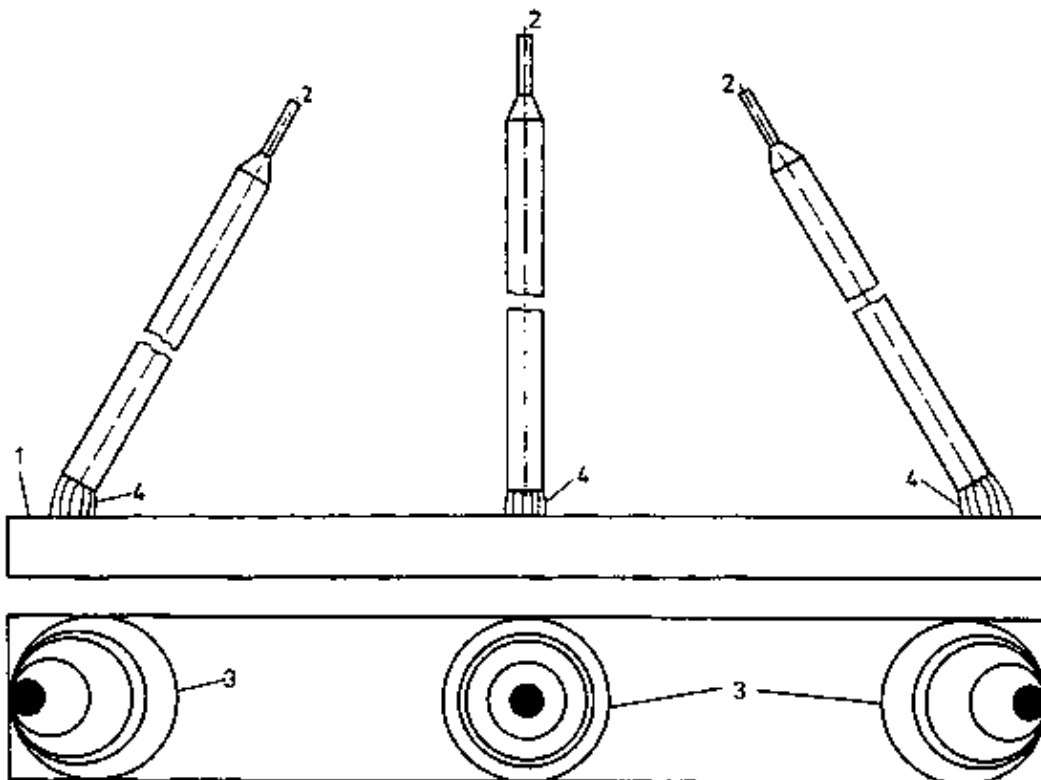

- 1 Positive pole, 2 Negative pole, 3 Lines of magnetic field, 4 Arc

Fig. 2 Magnetic field with the electrode in an inclined position

Give the following rule of thumb to the trainees

"40 Ampere per millimetre of core wire diameter"

- electrode

Make a distinction between bare electrodes and coated electrodes. Further, only tell the trainees that there is a large number of electrodes of which the electrodes for the particular application have to be selected.

- no-load voltage or open-circuit voltage

Explain the term of no-load voltage or open-circuit voltage. In this connection, enter into particulars on labour safety.

- non-insulated electrode holder
- hazards when working in moist rooms and rooms of limited freedom to move or in pits.

- welding positions

Draw simplified blackboard sketches of the various welding positions (see Fig. 4). Ask one trainee to describe the positions briefly. Pay particular attention to this sub-section because it is of fundamental importance to the further sub-sections.

This also applies to the next terms, namely,

- joint (of the metals to be welded)
- form of groove
- type of weld seam.

At first give definitions of the terms and explain them. The proceed as follows.

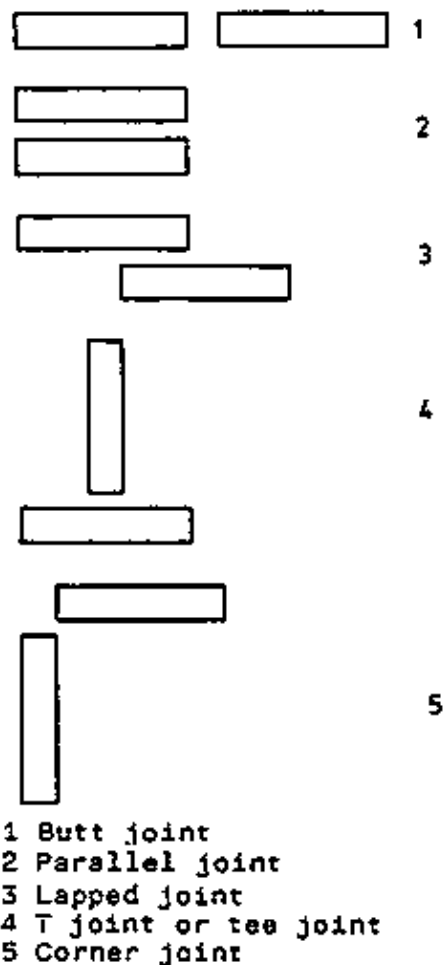

Fig. 3 Joints

Draw a blackboard sketch of Fig. 3. Coordinate the joint with the relevant weld. Repeat the position of the parts to be welded relative to each other. Pay attention to the fact that the trainees use the correct name for the various joints of the metals to be welded.

Fig. 4 Welding positions



1 "g" – position = gravity or boat-form position

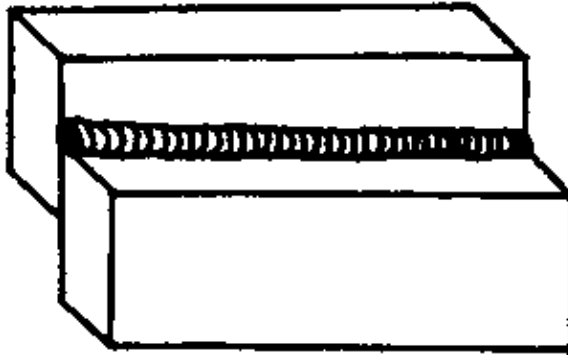

2 "h" – position = horizontal position

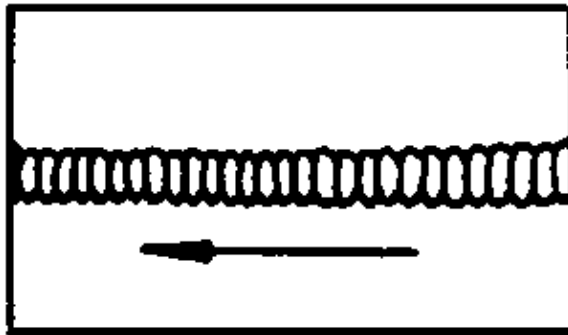

3 "c" – position = cross or transverse position

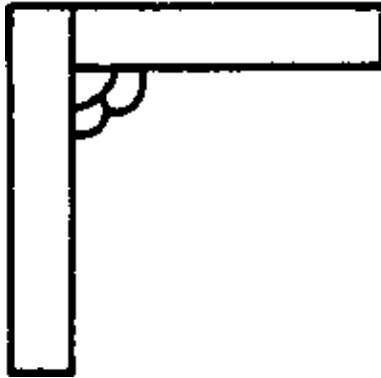

4 "o" – position = overhead position

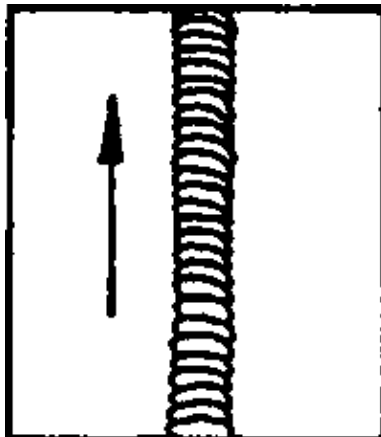

5 "v" – position = vertical position

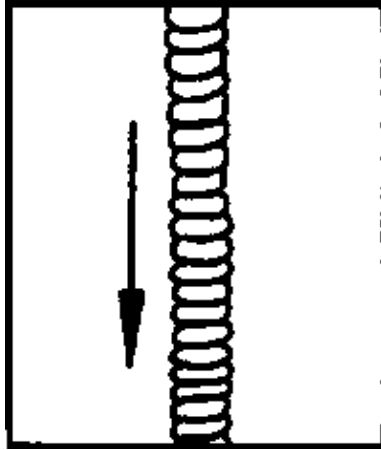

6 "v-d"-position = vertical-down position

5. General Labour Safety

This Section must play a special role in the practical training of electric welding. Preservation of health of the trainees must be the highest maxim in training.

Just in electric welding there are many hazards. Therefore, everything depends on familiarising the trainees with the regulations of labour safety for this method of welding in such a manner that they always bear them in mind and proceed accordingly. Experience has shown that the trainees grow weary when prohibitions and hints are merely enumerated. Their attention will be distracted. Therefore, you should set great store by their active cooperation. Induce the trainees to think over the labour safety regulations and their particular importance by putting relevant questions.

Show illustrations of accidents and describe the consequences of accidents which were due to the non-observance of the relevant regulations of labour safety.

Before the beginning of any practical training, question the trainees about their knowledge of labour safety regulations. Request the trainees to learn the content of these regulations by heart.

During training take care that the relevant regulations of labour safety are strictly observed. Negligence should be discussed with all trainees. Blame trainees for the non-observance of regulations and praise those trainees who pay attention to these regulations and observe them consciously. You should make it a rule to see to it that not a single trainee will weld with incomplete weldor's wearing apparel, defective weldor's screen and defective equipment and tools. In your explanations, place particular emphasis on the following items:

- hazards due to ultraviolet rays, infrared rays, light and heat radiation of the arc
 - hazards due to electrical current
 - hazards due to gases and weld smoke
 - hazards due to fire
 - general hazards
-
- dalliance and teasing at the working place
 - wearing of rings, watches, neck-laces, etc.
 - leaving welding specimens without supervision, etc.

After having repeated the most important subjects of labour protection, enter into detail on fire protection. Items of particular interest in this respect are:

- fires which can be caused by. the arc
-
- spatters flung about (sparks thrown off)
 - slag
 - the electrical current
 - combustible gases and liquids

Inform the trainees of their duty they have to perform when fire breaks out.

Ask the trainees to confirm your instruction about labour safety and fire protection by their signature in a special booklet.

After the your labour safety instructions, which have to take place regularly, you should exercise such an influence on the trainees that they readily pay attention to the observance of the labour safety regulations.

In this connection, pay attention to the following items:

- observance of the labour safety regulations at the own working place,
- drawing the attention of other trainees to possible and concrete hazards that may exist in the scope of responsibility of the latter and of other workers,
- active participation in the removal of hazards, purposeful acquisition of knowledge of health and labour safety and fire protection.

Emphasise the importance of labour safety, using concrete examples of practice. Enter into particulars on the conditions given in the enterprise in question.

Inform the trainees of the ways and possibilities of avoiding industrial accidents.

- Use of weldor's protective clothing, firm shoes, protective helmets, weldor's screen, weldor's gloves, leather apron
- Appearing at the working place in a considerate and not playful attitude
- Working attentively and in a concentrated manner
- Proper and correct use of the specified means of work and accessories
- Execution of the work in accordance with the rules of good workmanship

Always bear in mind that, especially in electric welding, great dangers of accident are involved when the labour safety regulations are not observed. Again and again point out this fact to the trainees.

6. Welding of Single Beads "g"

Explain to the trainees that the welding of single beads forms the basis of all further welding exercises. Bear in mind that the trainees will get into touch with the arc welding process for the first and, therefore, prepare particularly carefully for these sections.

Define the term of "single bead".

Demonstrate all operations involved in single bead welding properly and precisely. Continuously direct the trainees during their exercises and give them the required assistance. Observe the trainees during their exercises closely and correct their errors immediately. Analyse and discuss the errors occurring with all trainees.

6.1. Preparing the Exercise Plates

Tell the trainees the dimensions of the required exercise plates and their condition.

- Welding sample plates are used in the dimension of 200 x 150 mm, 10 to 12 mm in thickness.
- They must be plain and have a clean surface.
- The contour in the specified dimensions is obtained by gas cutting or by shear cutting.

Show a welding sample sheet or plate having an irregular surface with direct accumulation and show how it is straightened and cleaned.

Point out that pores can be formed in the material to be welded when the welding sample plate has not been cleaned in order to remove oil, grease, paint or rust.

- The formation of pores is a decrease in quality.

Place the plane and cleaned plate in front of you in such a manner that the longer side is parallel to you and draw a chalk line across the centre of the plate.

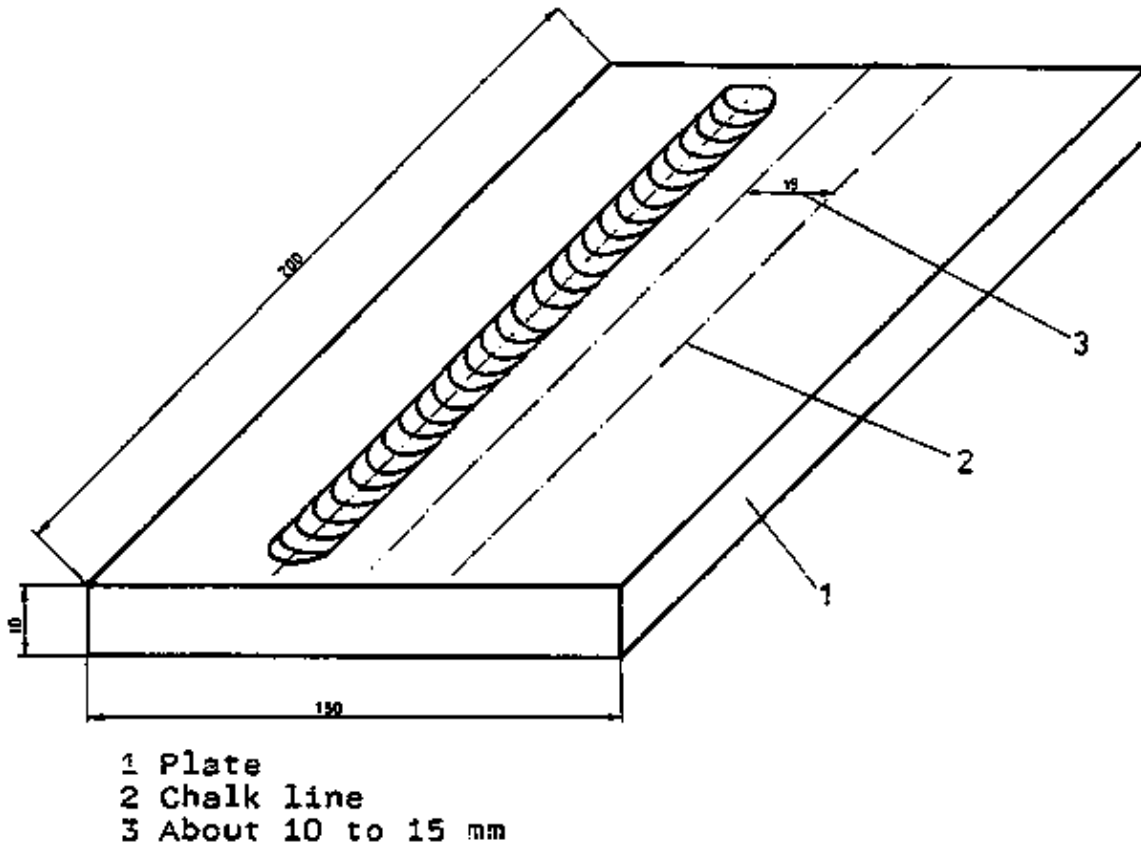

Fig. 5 Welding, sample plate

Now, allow the trainees to prepare their welding sample plates!

6.2. Welding of the Single Beads

For the welding of single beads, have used the electrode E 43 RR (B) with a core wire diameter of 4 mm, 450 mm in length. Now, initiate the trainees with the setting of the current intensity.

Repeat the items upon which the setting of the current intensity is dependent:

- core diameter
- coat thickness of the electrode
- welding position
- form of weld
- pass which is to be welded
- thickness of the material

Explain the setting of the current intensity to the trainees according to the following rule of thumb.

(Explanation: m = medium-thick, t = thin and v = very thick)

- For electrodes with medium-thick coat 40 A per mm of core diameter

- For electrodes with a thin coat, 50 to 50 A are subtracted from the current intensity determined according to the above rule
- For electrodes with a very thick coat, 30 to 50 A must be added to the current intensity determined

Ask the trainees which current intensity is to be set:

- core diameter = 4 mm
- electrode provided with medium-thick coat

Tell the trainees that the correct setting of the current intensity largely depends on the experience of the weldor. Therefore, the current intensity must always be set while considering the arc.

Now, explain the sequence of operations involved in the welding of single beads!

Igniting and maintaining the arc

Demonstrate which operations have to be performed before welding.

- Clamping the electrode in the electrode holder (welding pliers) and connection of the cable with the negative (-) pole of the welding current source.
- Fastening of the earth clamp to the welding table and connection of the cable with the positive (+) pole of the welding current source.

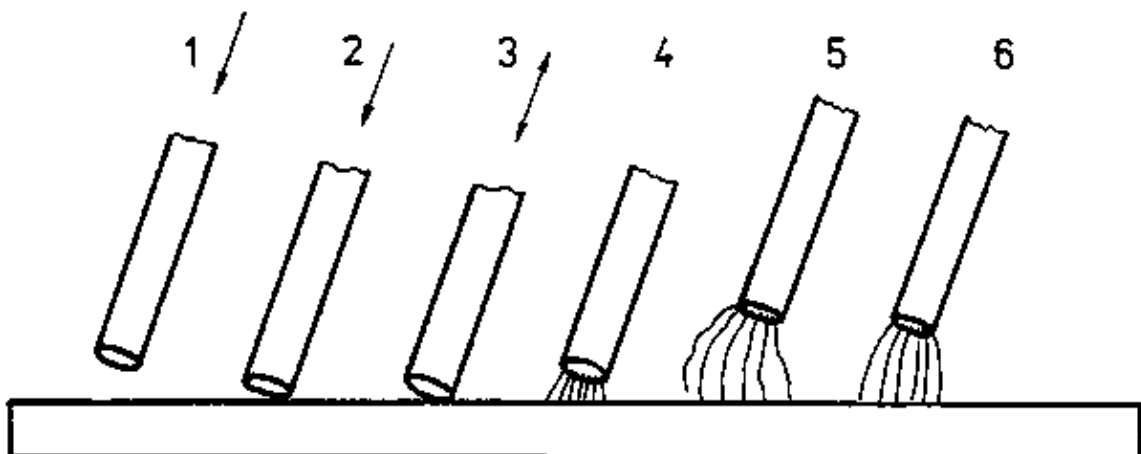

- 1 Touching the electrode end to the material to be welded
- 2 Touching the electrode end to the material to be welded
- 3 Touching and raising the electrode
- 4 Arc is too short
- 5 Arc is too long
- 6 Correct length of arc

Fig. 6 Igniting and maintaining the arc

Information about labour safety

Order the trainees to observe the following remark regarding labour safety.

To avoid an electrical accident, the welding current source is switched on as the last operation!

Enter into particulars on the consequences of the non-observance of this instruction.

Inform the trainees that the length of the arc can also be calculated on the basis of a rule of thumb.

– Up to an electrode thickness of 5 mm, the arc length is equal to the core diameter.

– With an electrode thickness of more than 5 mm, the arc remains constantly 5 mm.

Explain how the arc is ignited and maintained. Point out that this process is not always without a hitch. During the first trials it may occur that, when igniting, the electrode sticks to the workpiece.

Explain and demonstrate how to react to the sticking. Again give information about labour protection.

Electrode position

Describe how – after the igniting of the arc – the electrode must be brought into a certain positions.

– In transverse direction, it must form an angle of 90° with the workpiece while in longitudinal direction the angle between electrode and workpiece should be 70° .

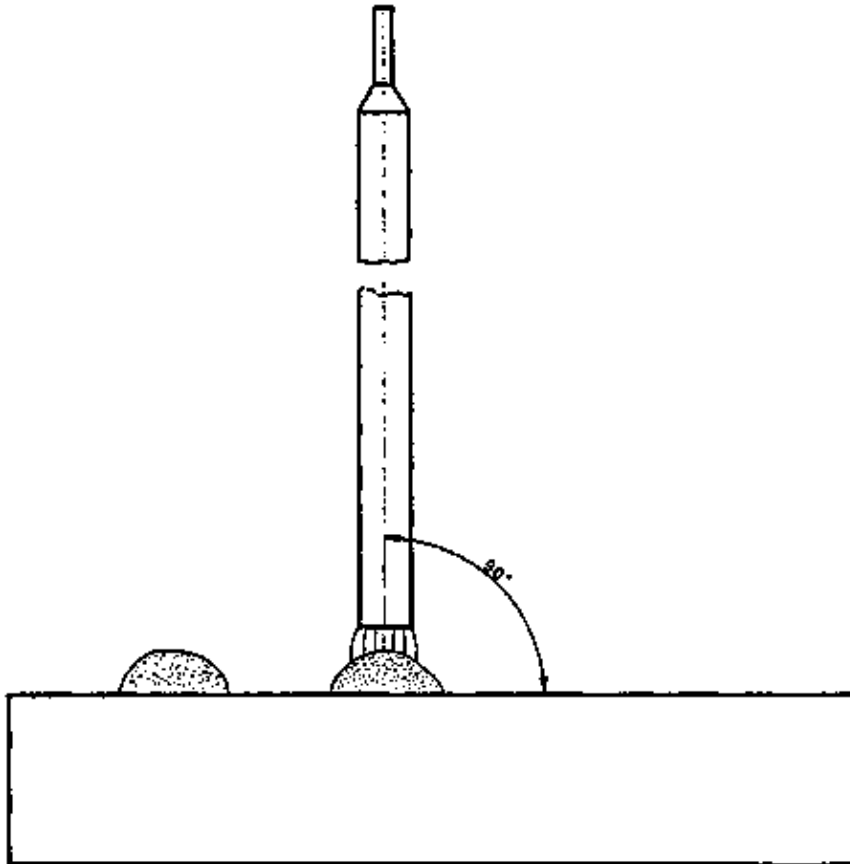

Fig. 7 Electrode position in transverse direction

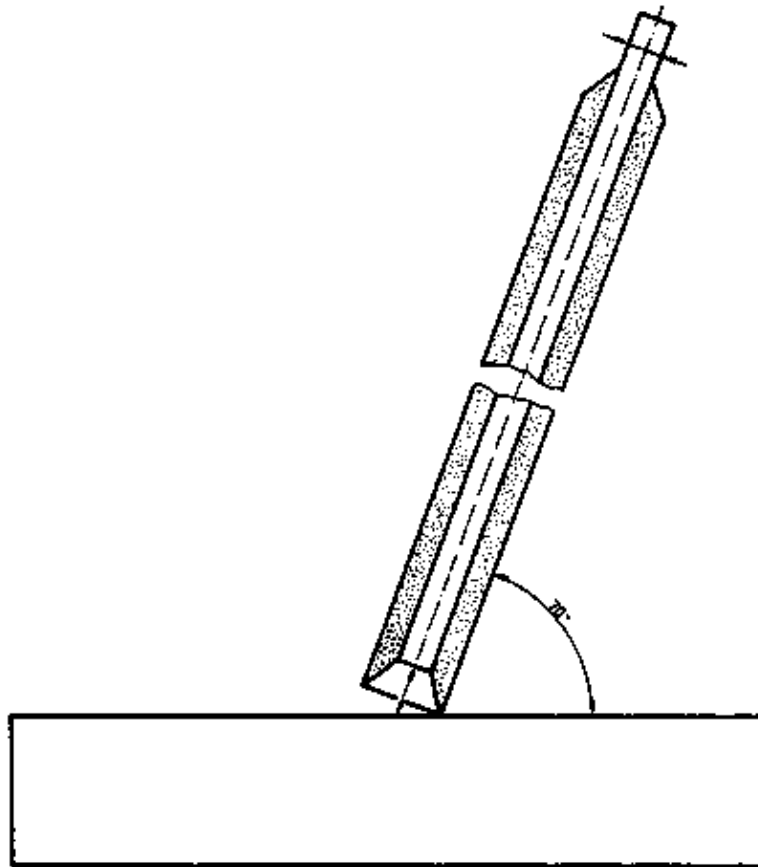

Fig. 8 Electrode position in longitudinal direction

Welding the bead

Now demonstrate the process of welding single beads. Take care that, before welding single beads, the deslagging hammer, wire brush and electrodes must be kept in readiness.

Point out the following items to the trainees:

- For welding single beads, the welding direction is from the left to the right.
- At the end of the chalk line, the electrode is kept stationary at the spot for a moment in order to fill up the end crater.
- Then the electrode is withdrawn in the direction of the already welded bead for about 10 mm and suddenly lifted and, thus, the arc interrupted.
- The bead height should be about 5 mm and the width of the bead about 10 mm
- In order to achieve the desired width, the electrode must be moved in a staggered manner.
- During welding, the arc must be observed in order to be in a position to distinguish between the fusing material and the liquid slag. (The colour of the parent material is always darker than that of the slag.)

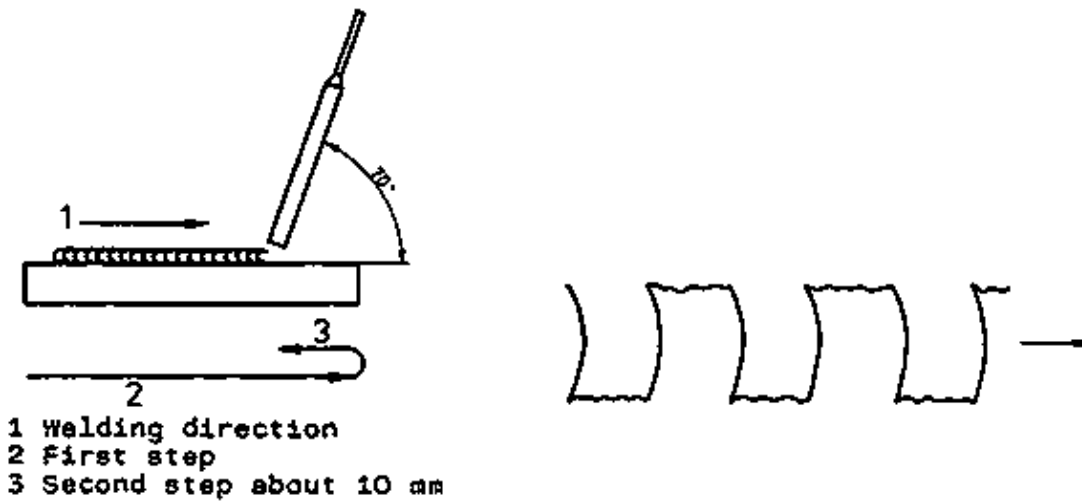

Fig. 9 Sequence of steps in electrode motion

Now show the welding sample plate finish-welded

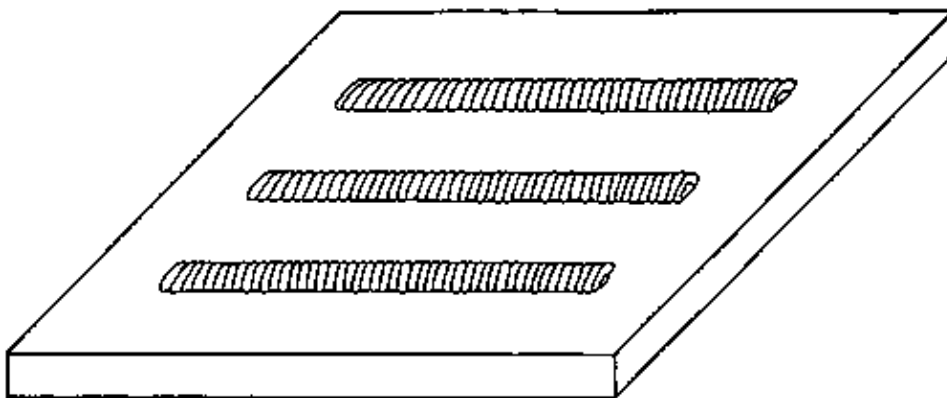

Fig. 10 Welding sample plate finish-welded

Blow effect and corrective measures

In summarising the above instructions point out that the position of the arc, the oscillating motion and guidance of the electrode are of decisive importance to the appearance of the single bead.

To this it should be added that these factors alone do not decide the issue because the blow effect must also be controlled.

Repeat the origin of the blow effect.

Demonstrate how to counteract the blow effect.

After the trainees have welded the beads, ask them to remove slag and weld spatters and carefully clean the surface of the plate.

Then the welding samples can be judged.

Instructions for labour safety

Take care that protective goggles, are worn for cleaning the welding sample plates.

Before cleaning the plates must be allowed to cool down!

For illustration, keep in readiness a sufficient number of weld samples or welded specimens.

Evaluation of the surface of single beads

Disclose the evaluation directions for an optical assessment.

- Uniformity of the height and width of the beads
- Straightness of the beads
- Formation of ripple
- Cleanliness of the weld sample (weld spatters and particles of slag removed).

Show welded specimens which you should have kept in readiness and explain the faults involved.

Fig. 11 Welded specimens



1 Good single bead



2 Welded bead with weld defects



- 1 correct height of the bead
- 2 bead is too shallow
- 3 bead is too high
- 4 end crater

Fig. 12 Welded specimen (cross-section of the bead)

Causes of weld defects

Once more allow the trainees to have a look at the welded specimens including defects and then give them the respective leaflet.

Subsequently, allow the trainees to exercise the welding of single beads.

Remove the defects together with the trainees. Take care that the trainees observe discipline, order and tidiness at the working place.

Help the trainees by individual demonstrations or by guiding their hands to achieve the required partial aim of training!

Again and again point out to the trainees that they have to use sparingly both basic materials and filler metals. If typical welding errors occur in exercising, analyse and discuss them in the collective.

Evaluation of the Section "Welding of Single Beads – g –"

With the conclusion of the above Section, the trainees should have acquired the following knowledge, abilities and skills:

- observance of the relevant labour safety regulations and order and tidiness at the working place
- preparation of the welding sample plates
- selection of the electrodes and setting the welding current intensity
- igniting the arc
- maintaining the length of the arc
- moving the electrode for welding single beads

- measures for neutralising the blow effect of the arc
- optical control and judgement of the welded specimen
- identification for weld defects

Examples of questions and problems for the Section "Welding of Single Beads – g –"

1. Outline the operations for preparing the welding of single beads!
2. Quote the rules of thumb for setting the welding current intensity and the length of arc!
3. Explain the operation of igniting and maintaining the arc!
4. Which are the corrective measures for counteracting the blow effect of the arc?

7. Building-up Welding "g"

Explain the use of building-up welding in horizontal position to the trainees.

Define the term of building-up welding which is also known as surface welding. Compare the process of building-up welding with the process of welding single beads.

Tell the trainees the welding electrodes to be used. In this connection establish the link to theoretical lessons. Repeat the designation of electrodes and show them to the trainees. Indicate the welding current intensity.

7.1. Preparing the Exercise Plates

Tell the trainees the condition and dimensions of the plates to be used for the exercises?

- The plate used has the dimensions of 80 x 100 mm, 10 to 12 mm in thickness (see Fig. 13),
- The exercise plate must be plane and have a clean surface.

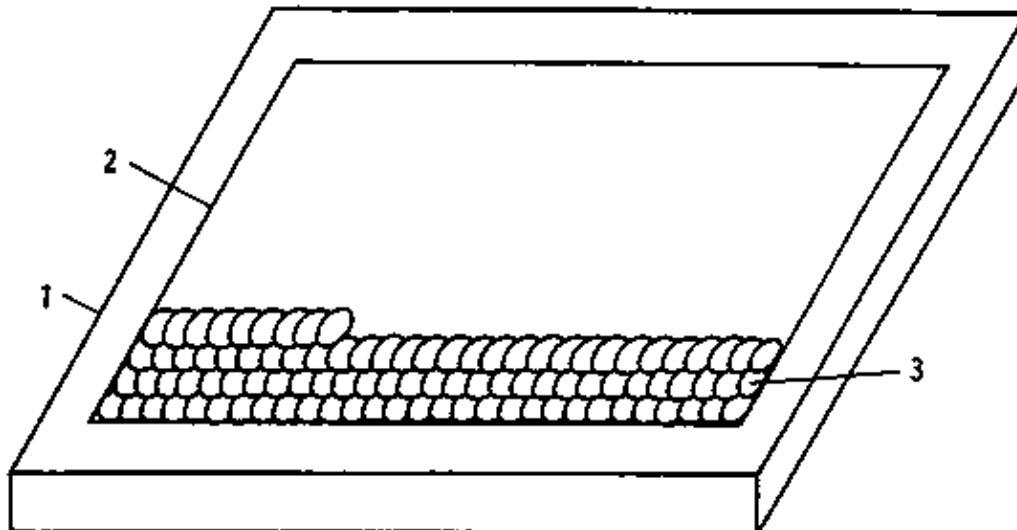

- 1 Exercise plate
- 2 Contour of the area to be welded
- 3 Weld beads

Fig. 13 Building-up welding in horizontal position

The trainees should take a mental note of the following rule.

Successful building-up welding calls for metallically clean plate surfaces!

Show a plate with an irregular surface which is not clean and show how it is straightened and cleaned.

The plate surface must be cleaned with a wire brush to remove rust, scale, remains of paint, oil and grease, Grinding over may be required.

Check the preparation of the exercise plates!

7.2. Welding a Surfacing Weld

- An area of 60 x 80 mm is to be welded.
- The height of the seam should be 3 to 4 mm.

Draw the contour of the area to be welded, having the dimension of 60 x 80 mm, on the exercise plate by means of chalk or a lead pencil.

Ask the trainees to draw the above contour on their exercise plates. Check this operation, measure the contour and do not allow any deviation from the specified dimensions!

Now demonstrate the execution of the building-up welding.

Place the exercise plate in front of you in such a manner that it is parallel to you. Point out the following steps in operation to the trainees:

- Setting the current intensity to about 160 A
- Igniting the arc on the upper left border of the drawn line. Welding is from the left to the right.
- Maintain the length of the arc at about 4 mm. The electrode is not oscillated but draw straight ahead, taking into consideration that, for the first pass, the electrode must form an angle of 90° with the plate.
- When the right-hand border of the marked area has been reached with the electrode, the arc is shortened in order that the end crater will be filled well.

Pay particular attention to the counteracting to the blow effect. Experience has shown that this item of training presents great difficulties to the trainees.

- For the following weld bead, the electrode should form an angle of 70° with the horizontal surface of the work-piece.
- It should be borne in mind that the weld bead cover one third of the first pass.

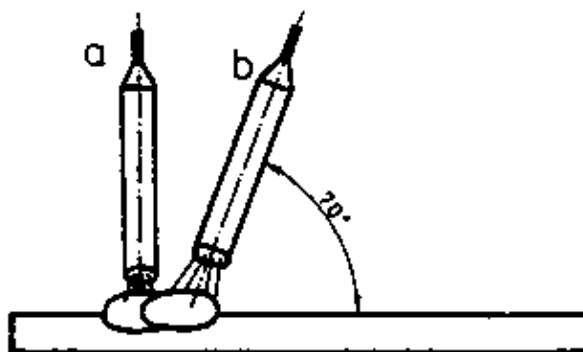

a Electrode position for the first pass

b Electrode position for the following passes

Fig. 14 Electrode position for building-up welding

In this way, a notch-free transition from the first to the second pass and the further passes is ensured.

- So-called filling of the end crater.

- Cleaning the seam and the plate to remove slag and spatters!
- The following passes have to be welded in the same way as the second weld has been welded until the area of 60 x 80 mm has been completed.
- Removing slag and spatters from the plate.

Critical examination of the welded exercise plates – welding defects and their causes.

Give comments on the build-up weld together with the trainees. Tell the trainees the assessment criteria to be used! Give your comments on the appearance of the seam and the accuracy to size.

Appearance of the seam

- Straightness of the beads
- Uniformity of ripple
- Points of start
- End craters
- Undercuts
- Weld spatters
- Slag inclusions

Accuracy to size

- Control of the dimension of 60 x 80 mm
- Control of the height of seam

Discuss the weld seam defects and their causes also in this case with the trainees.

Evaluation of the Section "Building-up Welding "g"

With the conclusion of the Section "Building-up Welding – g –". the trainees should have acquired the following knowledge, abilities and skills:

- observance of the relevant labour safety regulations and order and tidiness at the working place
- preparation of the weld sample
- control of the process of building-up welding in "g"-position
- identification of typical welding defects in fillet welds
- assessment of their work

Examples of questions for the Section Building-up Welding "g"

1. Explain the term of "building-up welding" also know as surface welding!
2. What is the field of application of building-up welding?
3. What are the effects of dirty plate surfaces on the quality of the build-up weld?
4. Which measures are taken to prevent undercuts?