

**Electric Welding 4 – Course: Techniques of Electric Welding.  
Methodical Guide for Instructors**



# Table of Contents

<b>Electric Welding 4 – Course: Techniques of Electric Welding. Methodical Guide for Instructors</b> .....	<b>1</b>
0. Preliminary remarks.....	1
1. Square butt welding in gravity position.....	2
1.1. Preparation of the training plates.....	2
1.2. Tacking the square butt weld.....	2
1.3. Welding the square butt weld.....	3
2. Edge fillet welding in the horizontal and the semioverhead position.....	5
2.1. Preparation of the plate specimens.....	5
2.2. Tacking the edge fillet weld.....	5
2.3. Welding the edge fillet weld in the horizontal and the semioverhead position.....	6
2.4. Evaluation of the completed edge fillet welds.....	8
3. Horizontal–vertical V type welding.....	9
3.1. Preparation of the plate specimens.....	9
3.2. Tacking the V type weld.....	10
3.3. Welding the V type weld.....	10
3.4. Evaluation of the finished V type weld – weld faults and their causes.....	15
4. Pipe butt welding.....	17
4.1. Preparation of the pipe specimens.....	18
4.2. Tacking the pipe butt weld.....	18
4.3. Welding the pipe butt weld.....	19
4.4. Evaluation of the finished pipe butt weld.....	26
5. Guidelines for the examination.....	27
5.1. Designation of the examination.....	27
5.2. Admission to the examination, welding permit.....	27
5.3. Execution of the examination.....	28
5.4. Evaluation of the examination.....	41



# Electric Welding 4 – Course: Techniques of Electric Welding. Methodical Guide for Instructors

CRYSTAL

Lehr- und Lernmittel,  
Informationen, Beratung

Educational Aids  
Literature, Consulting

Moyens didactiques,  
Informations, Service-conseil

Material didáctico,  
Informaciones, Asesoría

Feedback: IBE e.V.  
90-32-0604/2



Deutsche Gesellschaft für  
Technische Zusammenarbeit (GTZ) GmbH

Institut für berufliche Entwicklung e.V.  
Berlin

Original title:  
"E-Schweißen 4"

Author: Dietmar Mühs

First edition © IBE

Institut für berufliche Entwicklung e.V.  
Parkstraße 23  
13187 Berlin

Order No.: 90-32-0604/2

## 0. Preliminary remarks

The present methodical instructions for the impartation of knowledge, abilities and skills in electric welding have been developed for instructors of practical vocational training. These methodical instructions are intended for the instructor to give him help and suggestions in preparing and carrying-out the practical vocational training. Ways of solution are proposed to the instructor showing him how he can reach the aims in his pedagogical activities. The methodical instructions are arranged in such a way that the trainees are systematically familiarised with

- square butt welding in gravity position
- edge fillet welding in horizontal and semioverhead position
- V type horizontal-vertical welding
- pipe butt welding

In this connection the preparation of the plates and the corresponding electrode manipulation are the focal points. Learning the above mentioned welds and welding positions represents a continuation of the methodical instructions of "Electric welding 1, 2 and 3". The sequence of learning the kinds of weld and

welding positions has been laid down on the basis of the experiences in the training of electric weldors. Consequently, mastering the welding of the types of weld and welding positions presented in the methodical instructions of "Electric welding 1, 2 and 3" is the basis of learning the types of weld and welding positions of these instructions. After having successfully passed the examination, the trainees are entitled to make

- square butt welding in gravity position
- edge fillet welding in horizontal and semioverhead positions
- V type horizontal–vertical welding
- pipe butt welding

at plates resp. tubes with a thickness of plates resp. wall of 6 to 12 mm.

## **1. Square butt welding in gravity position**

Present several types of welds to the trainees in the form of a blackboard diagram. Let one of the trainees select the square butt weld. In this connection, explain the types of position. Recapitulate the concept of gravity position. Define the concepts of the square butt weld and the gravity position.

Explain to the trainees that for sheet metal with a thickness of less than 4 mm butt welds can be carried out as square butt welds. Other than with V type welds, the side walls of the weld are not beveled. They remain angular.

### **1.1. Preparation of the training plates**

Inform the trainees of the required dimensions and condition of the training plates.

- Two 100 x 200 mm plates 3 mm thick are used.
- The seam edges must be angular.
- The plates must be flat and must have a clean surface.

To meet these requirements, prepare the plates accordingly by plate cutting.

Present an uneven, uncleaned plate and demonstrate how it is straightened and cleaned.

Draw the trainees' attention to the following main points:

- A possible burr due to plate cutting must be carefully removed by means of a file.
- The surface of the plate must be cleaned from rust, scale or paint residues, oil and grease by means of a wire brush.
- The groove faces must be free from scale drag lines, burr and other unevennesses. If required, the faces must be smoothed by "filing or grinding. –

Check the preparation of the training plates.

### **1.2. Tacking the square butt weld**

Demonstrate how the square butt weld is assembled and tacked.

Explain to the trainees that for all butt welds, a shrinkage occurs along and across the seam during and after welding. As for square butt welds little weld metal is deposited, i.e. little heat is introduced, the transverse shrinkage can be neglected as an influencing factor for the tacking of the weld.

Place the two plates on a flat back-up plate in such a way that a root opening of 2.5 ... 3.0 mm is obtained. Let the trainees themselves decide as to which root opening shall be used in the welding operation.

Note that beginners like to use a root opening of less than 2.5 mm. This will result in an inadequate through-welding. Demonstrate this fact by an experiment.

Point out to the trainees that square butt welding requires much practise and patience, that the root opening of 2.5 ... 3.0 mm must absolutely be adhered to, and that the tack-welding is carried out at the two outer ends of the square butt weld.

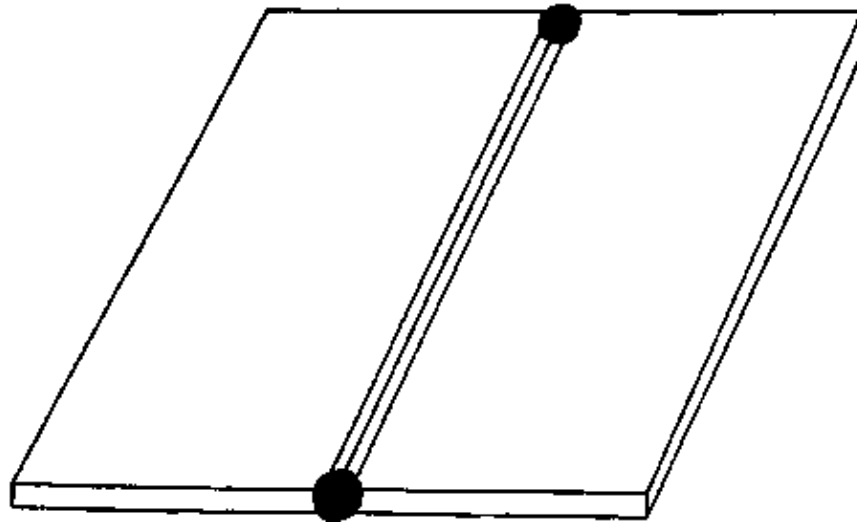

Fig. 1 Tacking the square butt weld

The tacks must be carefully cleaned from slags and spatter. The plates should be re-straightened once again in order arrange them absolutely within one plane.

Check the proper tacking of the V type weld by the trainees.

### 1.3. Welding the square butt weld

Explain to the trainees that a single-pass weld is carried out for a plate thickness of 3.0 mm, i.e. the cover pass and the root pass are welded within one run. The weld reinforcement is not specified here. However, point out that weld reinforcements must be kept as flat as possible. Such thin-material welding must be carried out very carefully, because a correction in subsequent passes, as it is done with V type welds, is possible.

- For square butt welding, use the "Anker" E 43 2 R 12 type electrode, with white colour marking.

Check the knowledge of the trainees concerning the electrode type. Summarize the advantages of this electrode as follows:

- The large-drop metal transfer provides for a good bridgeability.
- The electrode is suitable for all welding positions.
- It can be welded with d.c. straight polarity current, but also with a.c. current.

Point out to the trainees that, if this electrode is used, a somewhat longer arc must be held and a very smooth electrode manipulation is necessary.

Demonstrate square butt welding to the trainees. Here the trainees note the following sequence of welding operations:

- For the electrode with a core diameter of 3.25 mm, adjust the current strength to appr. 80 A.
- Preheat the tack area with a long arc. As soon as the tack begins to melt, welding is continued with a short arc (length 3.0 mm).

– As in single-pass welding the root and the cover pass must be welded in one run, the triangular electrode manipulation is used.

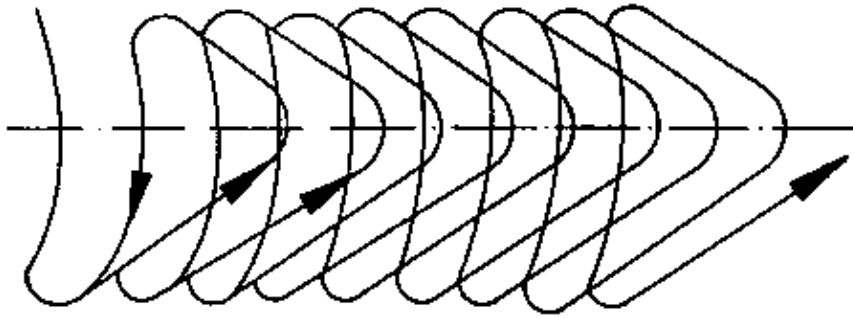

Fig. 2. Electrode manipulation in square butt welding

In your demonstration, discuss especially how the arc blow effect is counteracted.

– The square butt weld should first be carried out from left to right over 30 mm, thereafter the plate is rotated by 180° and the square butt weld is finished. This will counteract transverse shrinkage.

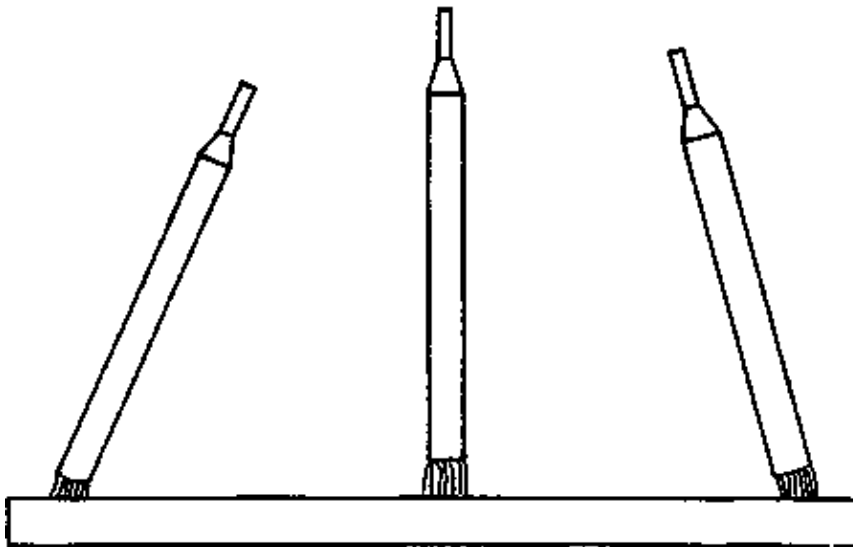

Fig. 3. Electrode position required to counteract the arc blow effect

– Holding the so – called "pear" ensures a satisfactory through-welding and a uniform root fusion.

– When the electrode has been changed, then after ignition the electrode is again held with a somewhat longer arc at the weld surface for a certain time; as soon as the arc strike area begins to melt, welding is continued using the triangular electrode manipulation as described above.

– During the welding operation, the length of the arc should always be adapted to the respective situation.

– A uniform heat input, and hence a uniform welding output is achieved by varying the arc length and the welding speed.

– Slag and weld metal should be observed very carefully. Slag appears light-red, weld metal appears dark – red.

Let one of the trainees again summarize the most important points. In a discussion, work out those points which determine the quality of a square butt weld.

- Variation of the welding speed (weaving)
- Variation of the arc length



- Variation of the rhythmic electrode manipulation
  - After the root welding has been completed, the square butt weld is carefully cleaned from slag and welding spatter.

Check the square butt weld for possible welding faults such as insufficient through-welding or excessive through-welding (fusion) of the root.

Let the trainees practise square butt welding.

Evaluate the exercise in a discussion.

### Evaluation of the Section "Square butt welding in the gravity position"

Having finished the training section of fillet welding, the trainees should have acquired the following knowledge, capabilities and skills:

- Observing the labour safety regulations including order and cleanliness at the working place
- Preparation of the welding specimen
- Mastering square butt welding in the gravity position
- Recognition of typical welding faults in square butt welds
- Evaluation of their own work

### Examples of questions on the Section "Square butt welding in the gravity position"

1. Describe tacking and welding of a square butt weld.
2. Explain the marking and the properties in use of the welding electrode employed.
3. What is the effect on the weld quality of a heavy contamination of the plates by oil, grease or paint?
4. What are the personal labour safety devices to be used by a welder?

## **2. Edge fillet welding in the horizontal and the semioverhead position**

To begin with, recapitulate the points to be considered in fillet welding. Thereafter recapitulate the concepts of an edge fillet weld and the horizontal and semioverhead positions.

Start the discussion of this section only if the trainees master square butt welding in the gravity position. Prepare a blackboard drawing of an edge fillet weld. Let one of the trainees sketch the horizontal and semioverhead positions of the electrode in the drawing.

### **2.1. Preparation of the plate specimens**

Inform the trainees of the plate dimensions. Discuss the condition of the plate specimens.

- 2 100 x 200 mm plates 3 mm thick and 2 50 x 200 mm plates 1 mm will be require.

As described in the preceding instructions, the plates must be prepared in a suitable way. Check the preparation of the plate specimens.

### **2.2. Tacking the edge fillet weld**

Demonstrate the assembling and tacking of the edge fillet weld.

- In this exercise, two main tacks (1) and (2) are placed, one at each end of the welding specimen.

– In addition, another 5 small tacks are necessary in order to prevent the thin sheet lifting off the thicker plate as the seam is welded.

The sequence of tacking can be observed from the figure below.

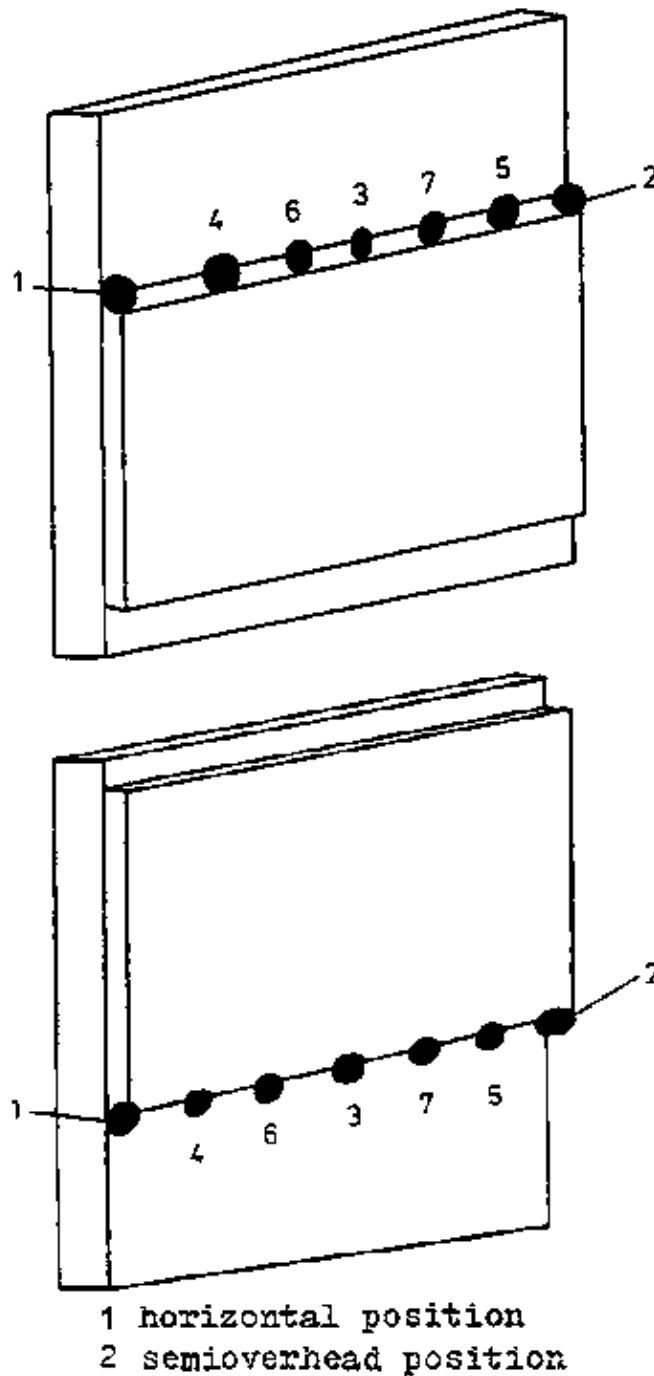

Fig. 4. Edge fillet weld with tacking sequence

Point out to the trainees that there must not be any air gap between the thin and the thick plates. If the two plates do not properly fit to each other, the thinner one will immediately burn away.

After completion of tacking, all the tack spots must be carefully cleaned from slag residues and spatter. Check the orderly tacking of the edge fillet weld by the trainees.

### 2.3. Welding the edge fillet weld in the horizontal and the semioverhead position

Use an "Anker" E 43 2R 12 type electrode. This electrode is an universal type for joint and tack weldings. Discuss the possible applications of this electrode. Explain to the trainees that this electrode can be used in

d.c. straight polarity welding or in a.c. welding. Use electrodes 2.5 mm in diameter.

Demonstrate edge fillet welding to the trainees first in the horizontal position. Subsequently demonstrate fillet welding in the semioverhead position. Point out the differences between fillet welding in the horizontal and the semioverhead position.

- The amperage for the electrode 2.5 mm in diameter is adjusted to 70 A when welding in the horizontal position and to 60 A in the semioverhead position.
- The tacked plate is clamped in the positioning fixture.

Point out to the trainees that an exact position of the electrode is necessary. It must be arranged at an angle of  $60^\circ$  from the thicker plate.

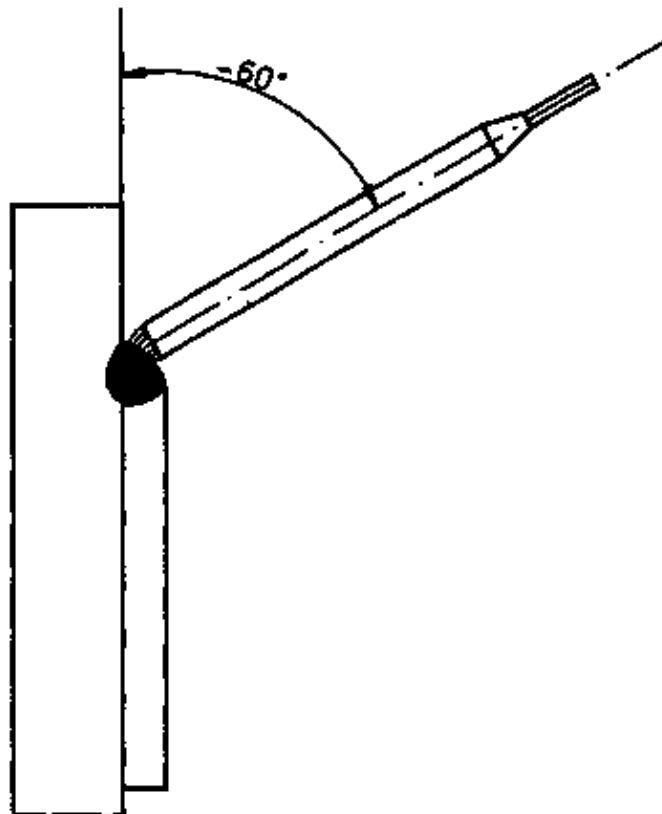

Fig. 5. Electrode position for edge fillet welding in the horizontal position

- To counteract the arc blow effect, the electrode position must be the same as with fillet welds, i.e. at the beginning and the end of the seam it must be tilted towards the centre, whereas in the central range it is held perpendicularly to the weld.
- There is no weaving of the electrode, but the welding is carried out in the stringer bead technique.
- Upon ignition, the thin sheet is touched (stippled) for a moment, and immediately thereafter the electrode is again pointed at the thicker plate.
- After finishing the weld, the plate must be carefully cleaned from slag and spatter.

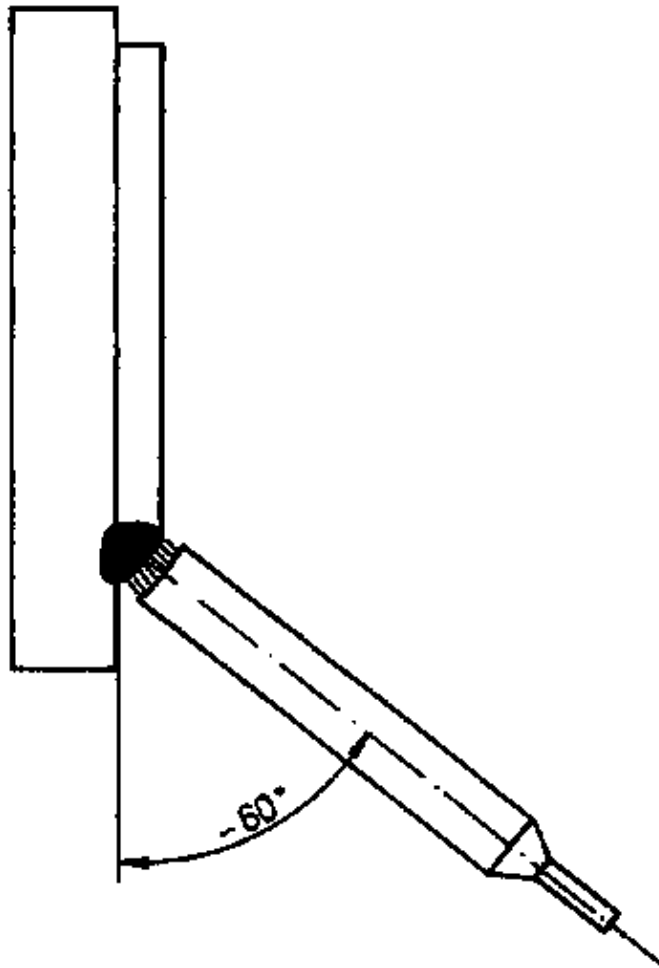

Fig. 6. Electrode position for semioverhead edge fillet welding

#### 2.4. Evaluation of the completed edge fillet welds

Evaluate the completed edge fillet welds together with the trainees. Inform them of the criteria of evaluation. Evaluate the appearance of the weld by

- the uniformity of the string bead
- the undercutting
- the welding spatter
- the end crater.

Discuss the weld faults with the trainees again. Compare properly welded and faulty specimens.

Weld faults and their causes

Weld fault	Cause
Poor bead ripple pattern of the string bead	non-uniform electrode manipulation
Undercutting	excessively long arc, excess current
The thinner plate is perforated	inadequate fitting of to the thicker one the thinner plate
Lack of fusion	amperage too low, excessive welding speed, unsuitable electrode manipulation

Subsequently, let the trainees practise edge fillet welding, first in the horizontal position and thereafter in the semi-overhead position.

## Evaluation of the Section "Horizontal and semioverhead edge fillet welding"

Having finished the training section of edge fillet welding, the trainees should have acquired the following knowledge, capabilities and skills:

- Observing the labour safety regulations including order and cleanliness at the working place
- Preparation of the welding specimen
- Mastering edge fillet welding in the horizontal and the semioverhead position
- Recognition of typical welding faults in edge fillet welds
- Evaluation of their own work.

## Examples of questions on the Section "Edge fillet welding in the horizontal and the semioverhead position"

1. Describe the properties of the welding electrode employed.
2. What measures do you take to protect yourself from falling weld metal drops and spatter in semioverhead welding?
3. Describe the weld preparation and the tacking of the edge fillet weld.
4. Explain the concept of a lap joint.

### **3. Horizontal–vertical V type welding**

Recapitulate the buildup of a V type weld in a discussion at the beginning of this section. This discussion should also include the positions. Let one of the trainees sum up the horizontal–vertical position.

- If two plates are butt–welded to each other at their edges, then this seam is called a butt–welded seam.
- For a plate thickness of more than 4 mm, a weld preparation is required. In the range from 4 to 15 mm a V type weld is chosen; for thicker plates double–V welds are applied.

Sketch the buildup of a V type weld on the blackboard. Sum up the terms associated with a V type weld in a discussion by having one of the trainees associate the respective term mentioned by you to an item on the blackboard sketch. For that purpose, use the methodical instructions for V type welding. Subsequently inform the trainees of the objective of this section.

It is useful to start practising horizontal–vertical V type welding not earlier than the trainees have acquired capabilities and skills in horizontal and semioverhead edge fillet welding. Therefore let one of the trainees carry out an edge fillet weld in the horizontal position, and another trainee, in the semioverhead position. Evaluate the weld together with the trainees. Accord praise to a good workmanship.

Summarize the most important points to be considered in horizontal and semioverhead edge fillet welding. Only thereafter enter into the discussion of horizontal–vertical V type welding.

#### **3.1. Preparation of the plate specimens**

Inform the trainees of the dimensions and the condition required for the plate specimens.

- Two 100 x 200 mm plates 10... 12 mm thick will be used.
- The bevel angle of the plates is 30°.
- The plates must be plane and must have a clean surface.

Check the preparation of the plate specimens.

### 3.2. Tacking the V type weld

Demonstrate the assembling and tacking of the V type weld in the horizontal-vertical position. For all seams, a shrinkage along and across the seam occurs during and after welding. Draw the trainees' special attention to the fact that with horizontal-vertical V type welds there is a very pronounced angular shrinkage.

The angular shrinkage increases with increasing number of inner and cover passes.

Fig. 7. Angular shrinkage in V type welds

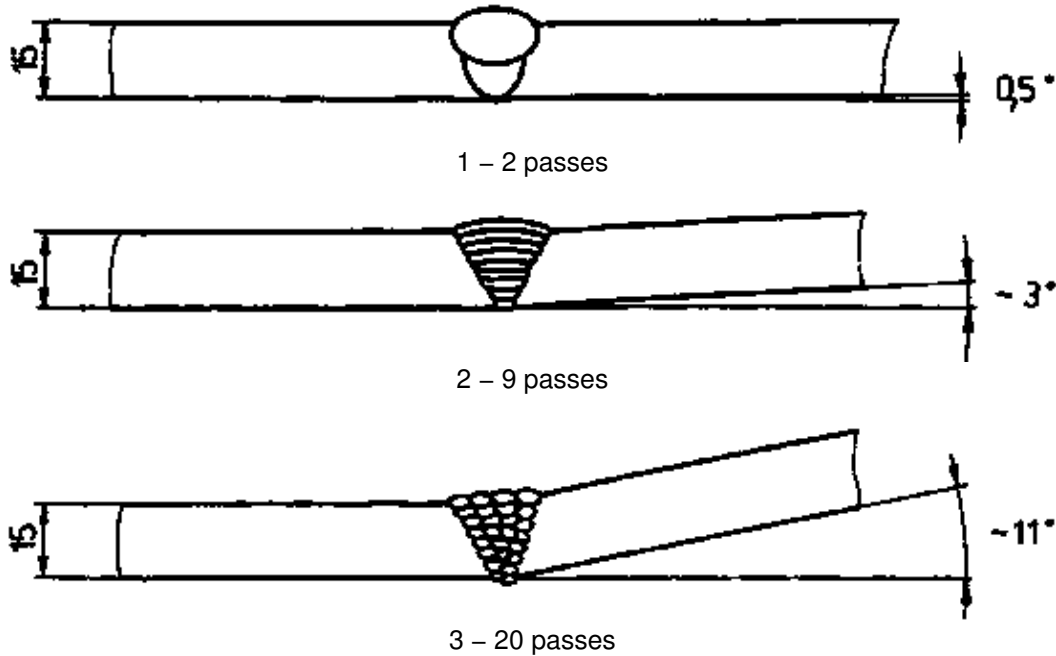

Recapitulate the tacking of the V type weld in the gravity and the vertical-up position. In a discussion, let the trainees find out how angular shrinkage is counteracted,

- Small plate strips 4 ... 4.5 mm thick are put under the plates to be welded on the left and right sides of the weld.

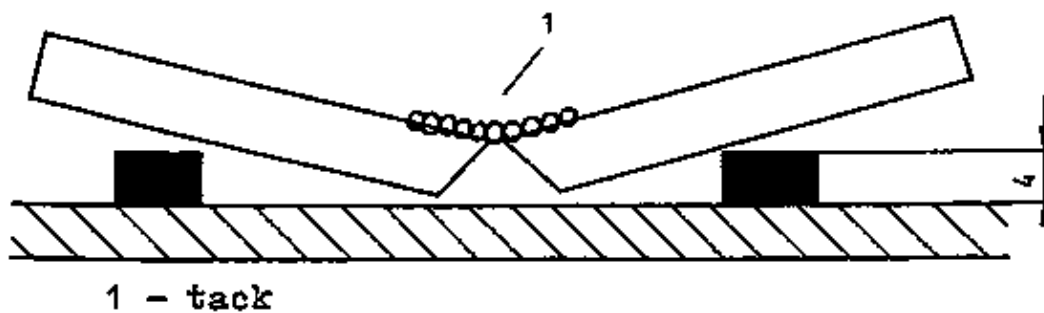
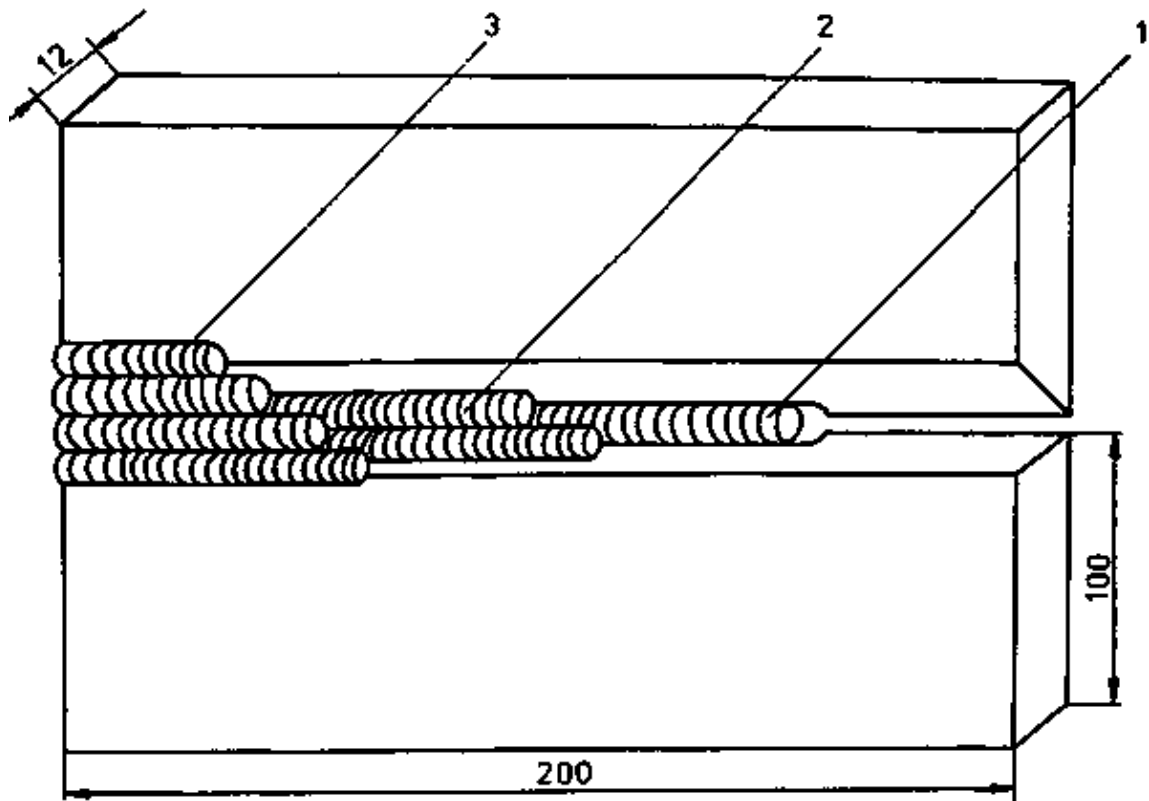

Fig. 8. Tacking the V type weld in a roof-like configuration

Thereafter proceed as specified for tacking the V type weld in the vertical-up position.

Check the proper tacking of the V type weld by the trainees. The tacks should be placed directly at the plate edges. Here care should be taken to achieve strong and clean tacks. If the tacks crack during root welding, the latter cannot be continued. After finishing the tack welding, the tacks should be carefully cleaned from slag residues and spatter. Check the proper tacking of the V type weld by the trainees.

### 3.3. Welding the V type weld



**1 - root pass; 2 - inner passes; 3 - cover passes**

Fig. 9. Weld buildup of the horizontal-vertical V type weld

Sum up the vertical-up V type welding. Subsequently, let the trainees discuss the differences between the welding techniques of the respective weld types in the vertical - up position.

#### Welding in the horizontal-vertical position

- For welding the root, inner, and cover passes, electrodes with a core diameter of 3.25 mm are used.
- The weld reinforcement must be within - 0, +2.5 mm.
- Use a "Titan" E 43 4RR (B) 22 type electrode -with a red colour marking.

Discuss the possible applications of such electrodes.

#### **3.3.1. Welding the root pass**

Demonstrate the root welding to the trainees.

Explain the individual welding operations to the trainees.

- The amperage for the electrode with a core diameter of 3.25 mm should be adjusted to appr. 90 to 100 A.
- The tacked specimen is placed on the table in such a way that the orientation of the weld groove is horizontal, i.e. transverse.

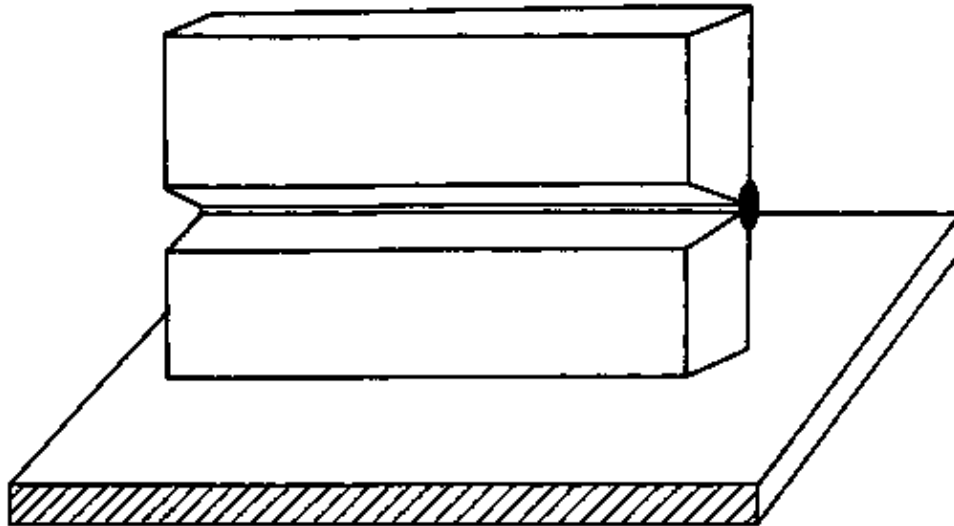

Fig. 9. Plate specimen arranged in transverse position

- In this exercise the direction of welding is from left to right again.
- The root pass is welded in the form of a horizontal U, using as short an arc as possible.



Fig. 10. Electrode manipulation in welding the root pass

In this case, too, the electrode is guided along an arc being open in the direction of welding.

- If the arc touches the seam edge, then again count in the usual rhythm: down two – three, up two – three, down two – three etc.
- The weld metal is deposited with a short arc at 2 – 3 in the centre of the groove in such a way that the arc pushes the weld metal through the web to the left side.

Point out to the trainees that

- the upper and lower seam edges should be melted to a sufficient degree.

Generally this hardly raises any problems in transverse seam welding. Special care should be taken in melting the upper seam edge. Here the arc should be kept particularly short, because otherwise the upper seam edge is heavily overheated. Discuss the consequences of a heavy overheating.

- When the electrode has been changed, then after ignition the weld metal is again pushed through the groove with a somewhat longer arc.

Explain and demonstrate to the trainees very insistently how the arc blow effect can be counteracted.

- At the beginning of the root weld, the electrode must be tilted in the direction of welding, and as the weld approaches the end of the plate, the electrode must be tilted oppositely to the direction of welding.
- In transverse seam root welding, the so-called "pear" (pear-shaped weld nugget) should also be held. This ensures proper through-welding and an uniform root fusion.

Point out to the trainees that

- the pear must form uniformly, because otherwise there will be a heavily sagged root or heavy undercutting (see the figure below).





Fig. 11. Right and wrong formation of the pear.

Thereafter proceed as specified in the instructions on "V type welding in the gravity position".

### 3.3.2. Welding the inner passes

Demonstrate the welding of the inner passes to the trainees. Point out the properties in common and the differences in V type welding between the different positions. The amperage must range between 130 and 140 A. This high amperage is required for the fusion of the root reinforcement and for the removal of minor slag residues at the seam sides.

- The electrode is guided as a string bead without weaving.

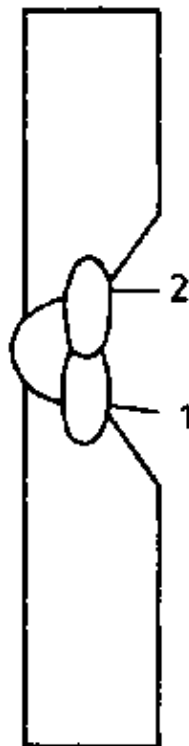

Fig. 12. Welding the 1st and 2nd inner passes

- The inner pass (1) is welded in so that it covers one half each of the root and the lower side wall of the seam.
- Care should be taken to avoid depositing too thick string beads.
- After depositing each string bead, slag and spatter must be carefully removed.
- After finishing the inner passes (1) and (2), the amperage can be adjusted to 120 A.

This lower amperage is intended to avoid overheating of the specimen for the remaining inner passes,

- The arc blow effect is counteracted in the same way as in root welding.
- The other inner passes are built up one upon another. Depending on the thickness of the deposited inner passes, a total of 6 inner passes is required for plates 10... 12 mm thick. The

number of inner passes required may also be greater, depending on the individual skill of the weldor.

The buildup of the inner passes is illustrated in the figure below.

– The V type seam is filled so that the last inner passes are 0.5 to 1.0 mm below the plate surface.

The remaining edge permits an orientation for welding the cover pass.

– To avoid overheating of the weld, it is necessary to interrupt the welding operation several times between the inner passes in order to provide for the required cooling.

– The end crater of all inner passes must be filled very carefully, which can be achieved by a reduction of the arc length.

– The electrode should be burnt off to a length of 40 mm.

Check the uniformity of the last inner pass welded by the trainees. Unevennesses must be smoothed out by chipping. Welding a satisfactory cover pass depends essentially on the appearance of the uppermost inner pass.

### 3.3.3. Cover pass welding

#### Methodical hint

Demonstrate welding of the cover pass to the trainees. Explain to the trainees that electrodes with a core diameter of 3.25 mm are used.

– The cover pass is welded in the stringer bead technique. Depending on the thickness of the string bead, 4 to 5 cover beads will be required.

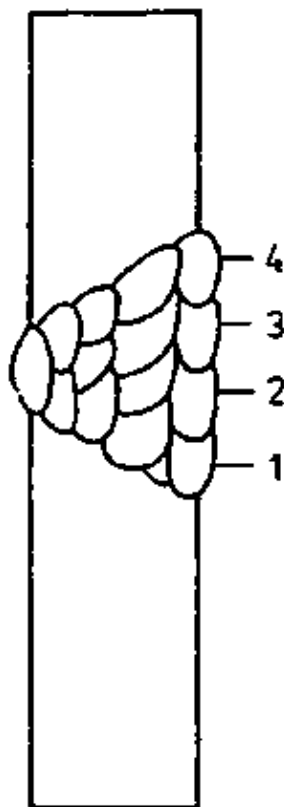

Fig. 13. Buildup of the cover pass

- The first and the last string bead must be carried out most exactly. Take care that the string beads fuse properly with the plate edge.
- For restarts of the arc reignition is done in the centre of the end crater. The end crater is filled by a slow, stippling weaving motion. Then the welding of the string bead is continued.
- The end craters of the cover passes must be filled carefully, which is achieved by reducing the arc length.

### 3.4. Evaluation of the finished V type weld – weld faults and their causes

Evaluate the finished V type weld together with the trainees. Inform them of the criteria of evaluation. Evaluate the appearance of the weld (cover pass and root pass), the accuracy to size and the appearance of the fracture.

#### Appearance of the weld

- Uniformity of bead ripples
- Appearance of the root
- Arc strikes
- End craters
- Undercutting
- Weld spatter

#### Accuracy to size

- Determine the three measuring points by means of a weld gage.

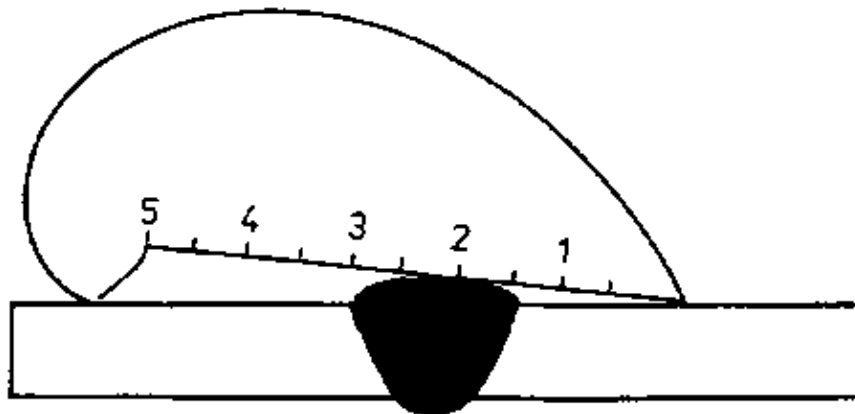

Fig. 14. Measurement of the weld reinforcement

Weld gage (1) for measuring the weld reinforcement. For V type seams welded in the horizontal – vertical position, a maximum weld reinforcement of + 2.5 mm is permissible.

#### Fracture appearance

To evaluate the fracture appearance, notch and break the V type weld.

- The V type weld is notched by planing–in. Take care that the notch is acute – angled and at least 4 – 5 mm deep.
- The specimen should be broken by means of a hydraulic press using the fixture shown in the figure below.

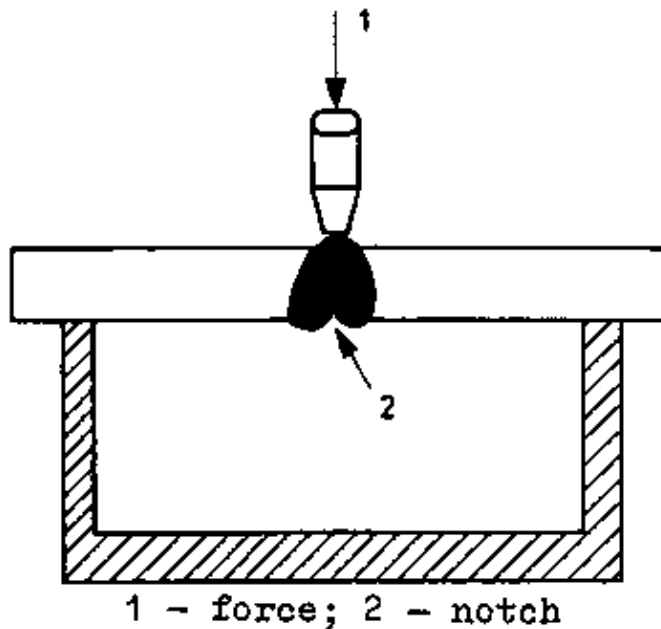

Fig. 15 Breaking of the notched weld (1 – forces; 2 – forces)

Demonstrate the notching and breaking of the welding specimens to the trainees.

Note on labour safety

Take care that the protective grating of the press is closed during the breaking operation. The hydraulic press should be operated with great care and circumspection.

Criteria for the evaluation of the appearance of fracture are:

- Melting of the root edges
- Slag inclusions
- Porosity
- Lack of fusion

Evaluation of the Section "V type welding in the horizontal-vertical position"

After finishing the training section of V type welding, the trainees should have acquired the following knowledge, capabilities and skills:

- Observing the labour safety regulations including order and cleanliness at the working place
- Preparation of the welding specimen
- Mastering V type welding in the horizontal-vertical position
- Recognition of typical welding faults in V type welds
- Evaluation of their own work

Examples of questions on the Section "V type welding in the horizontal-vertical position"

1. Describe the weld buildup of a V type weld in the horizontal-vertical position.
2. Compare the tendency to shrinking for a vertical – up V type weld with that of a horizontal-vertical V type weld.
3. What are the possible mistakes of a weldor which result in slag lines and slag inclusions?
4. Why does your trainer invariably demand order, safety and discipline at your working place?

## 4. Pipe butt welding

In a lecture tell the trainees the necessary information of pipe butt welding in the overhead, vertical – up, gravity and horizontal–vertical positions.

Inform the trainees of the object of this section.

- Acquiring the skill of pipe butt welding with the pipe axis being vertical or horizontal.

Fig. 16. Orientation of the pipe axis

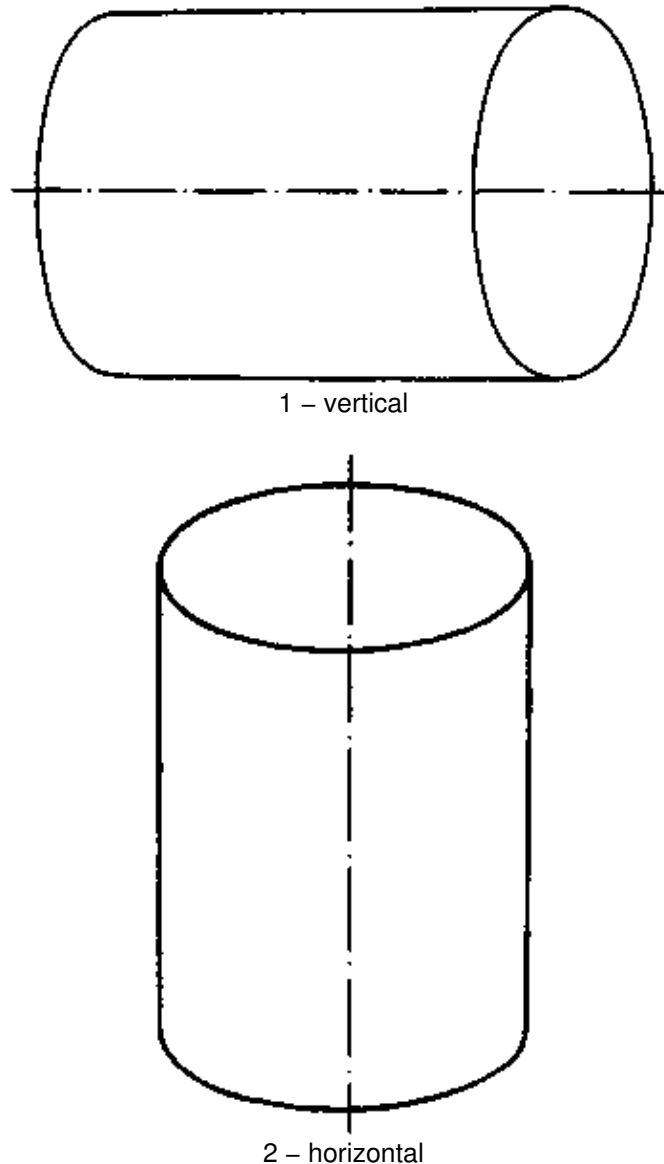

- Particularities of tacking a pipe butt joint
- Mastering the sequence of welding for pipe butt joints

The welding electrode to be provided for is a "Titan" 3 43 4RR(B) 22 type electrode with red colour marking and a diameter of 3.25 mm.

The electrode marking was already explained in the technical part of the training course. You should, however, point out again that this electrode is one with a very thick rutile covering. This electrode distinguishes itself by a small-drop metal transfer, which enables finely rippled seams and weld interfaces free of undercutting. It is suitable for all welding positions except for the vertical–down one. The electrode is used in d.c. straight polarity welding or in a.c. welding. For the electrode diameter, an amperage of 120 ... 160 A is suitable. In your explanations you should start from the previously acquired knowledge of V type welding in the gravity, vertical–up and horizontal–vertical positions. Discuss the overhead position separately.

#### 4.1. Preparation of the pipe specimens

Inform the trainees of the dimensions and the condition required for the welding specimens.

- Two 200 mm pipe lengths, 8 mm thick, nominal bore = 150 mm, are required.
- Chamfer the pipe lengths to prepare a bevel of 30 °. Chamfering is done by flame cutting on a pipe cutting device.
- Clean the pipe length carefully from rust and scale over a distance of 40 mm from the end to be welded.
- Take care that the two pipe length can be fitted to each other without any misalignment.

Possibly the fitting must be achieved by grinding or filing.

Check the preparation of the pipe specimens. Imprint the following principle on the trainees' minds: "A proper and exact weld preparation is prerequisite to successful pipe welding."

#### 4.2. Tacking the pipe butt weld

Demonstrate the assembling and tacking of the fillet weld. For that purpose, place the two prepared pipe lengths on a channel section in such a way that a root opening of 3.5 – 4.0 mm is obtained. Demonstrate the tack welding.

- 4 tacks with a length of 40 mm each are required. The arrangement of the tacks can be observed from the figure below.

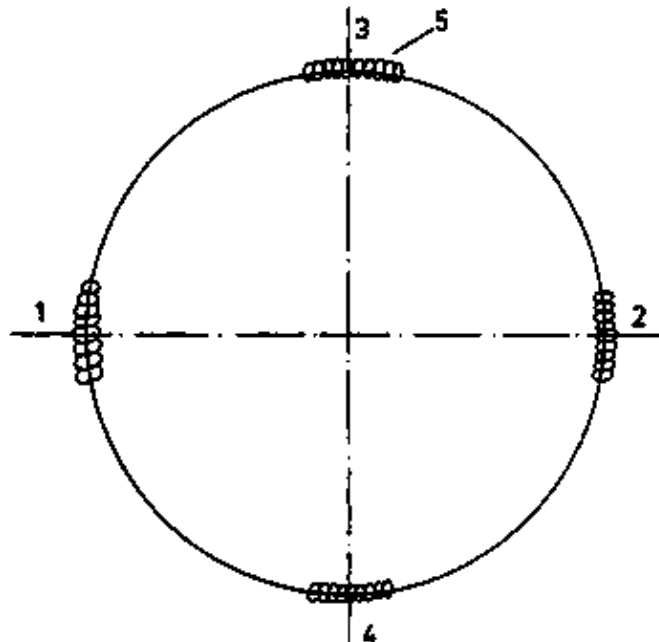

1, 2, 3, 4 – order of succession of the tacks  
5 – tack spot

Fig. 17. Arrangement of the tacks

- Each of the tacks should be welded in the vertical–up position. After finishing the tacks 1 and 2, the pipe is rotated until the tacks 3 and 4 are in the vertical–up position.

- Clean the tacks from slag and spatter by means of a deslagging hammer and a wire brush.

Check the proper tacking of the pipe by the trainees. For a better orientation during the welding operation, subdivide the pipe into four equal sections. Mark and identify these sections using oil chalk.

Observe the arrangement of the individual welding positions in the picture below.

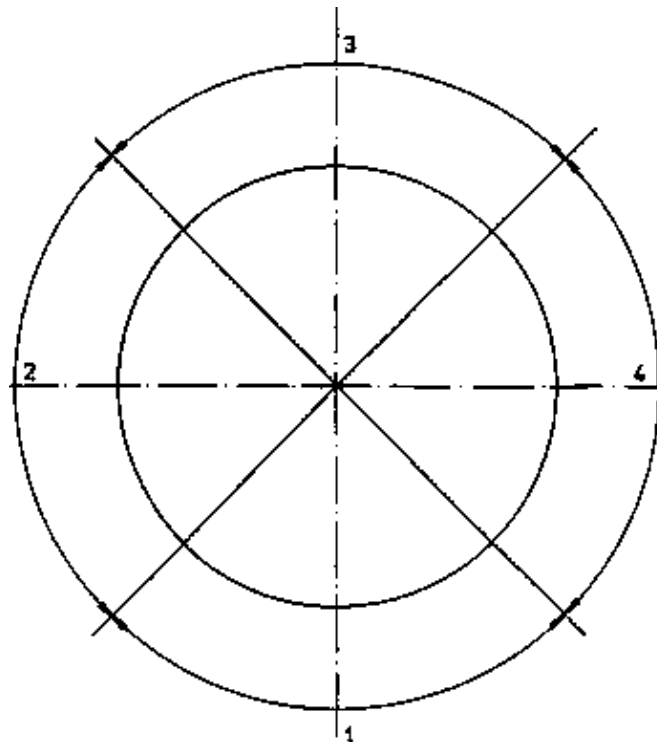

**Positions:**

- 1 - overhead**
- 2 - horizontal-vertical**
- 3 - gravity**
- 4 - vertical-up**

Fig. 18. Arrangement of the welding positions

Check the realization of this measure, which is very important for the trainees.

### 4.3. Welding the pipe butt weld

Demonstrate the welding of the pipe butt weld. Draw the trainees' attention to the following points of importance:

- The root pass must be welded first over the whole circumference of the pipe, followed by the inner passes and, finally, by the cover pass, which are also welded along the whole circumference.
- For welding in the semioverhead, vertical-up and gravity positions, clamp the pipe so that the pipe axis is horizontal.

Rotating the pipe during the welding process is strictly forbidden. Take special care that this interdict is obeyed.

Welding in the horizontal-vertical position is done with the pipe axis being vertical.

- For welding in the overhead, vertical-up and gravity positions, the pipe is clamped in a positioning fixture so that the pipe axis is horizontal.

Let the trainees adjust the height of the pipe so that the lowermost point of the pipe wall is closely above their head. The bearing of the trainee during the welding operation is of great importance. An unsuitable bearing will fatigue the trainee very rapidly in the overhead position, which has a very detrimental effect on the quality of the weld. Note the bearing of the trainee during welding in the overhead position as shown in the figure below.

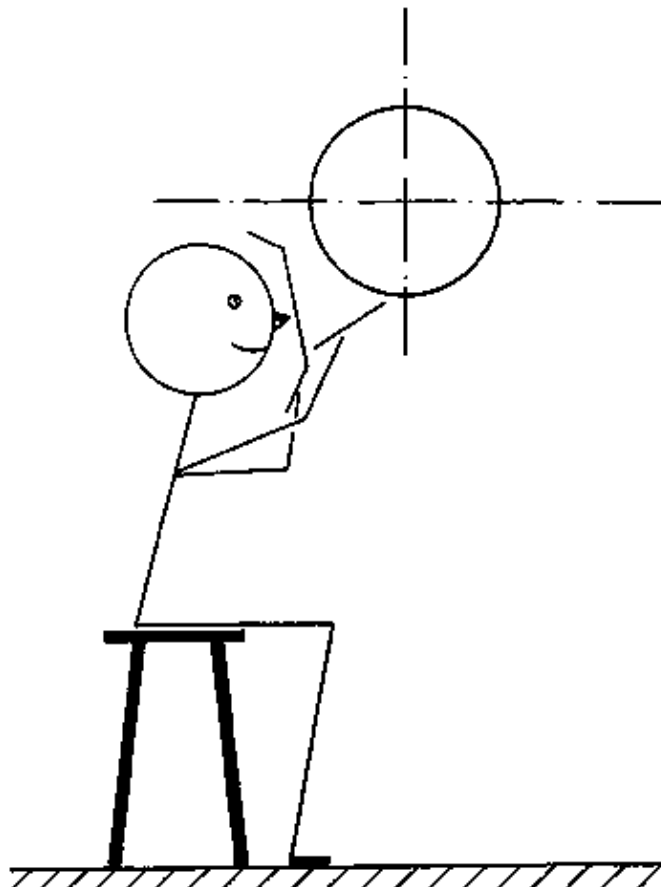

Fig. 19. Bearing during welding in the overhead position

Draw the trainees' attention to the fact that the height of the pipe can be readjusted for welding in the vertical-up position and the gravity position, respectively. Rotating the pipe, however, will affect the welding position and must be strictly forbidden. Take care that this interdict is obeyed.

In the horizontal-vertical position, unclamp the pipe from the fixture and put it on the welding table so that the pipe axis is vertical.

#### Note on labour safety

In the overhead position, labour safety requires special attention. Palling drops of weld metal and sparking especially endanger eyes and ears as well as the face; sparks may also fall down on the neck. Consequently, take care that the obligatory labour safety measures are obeyed to avoid the risks encountered. Make sure that the trainees obey the pertinent labour safety regulations and wear, for instance, a suitable head-covering, an ear-flap, and a leathern sleeve protector.

Explain the risks of overhead welding to the trainees.

#### **4.3.1. Welding the root pass**

##### Welding the root pass in the overhead position

Demonstrate the root pass welding to the trainees. Explain the following points to the trainees:



- The arc should be started at the tack No. 4 and the weld should proceed from there towards the tack No. 2.
- The root parts is "stippled" rather than welded at one stretch.
- The arc is started at the tack spot and then moved to the right towards the side wall of the seam. At the side wall, the arc is pulled away downwards. Now the arc is started at the right-hand side wall. It is moved across the root opening, guided to the left, and pulled away at the left-hand side wall. Thereafter the arc is re-started at the left-hand side. It is moved to the right and pulled away at the side wall of the seam. Now the arc is re-started at the right-hand side and moved to the left.
- Guiding the electrode in this way, weld the root pass up to the point which can be observed from the figure below.

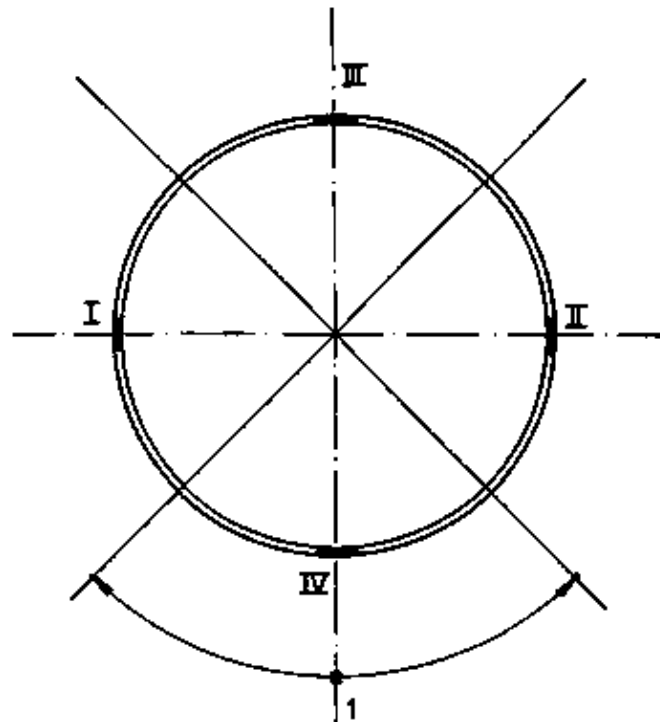

**1 - overhead position**  
**I, II, III, IV -**  
**tacking sequence**

Fig. 20. Welding sequence in the overhead position

- Subsequently, guiding the electrode in the same way as above, the remaining length of the root pass is welded from the tack No. 4 to the tack No. 1 up to the point shown in the figure above.

- Take care that the overhead position covers 1/3 of the total circumference of the pipe.

Welding the root pass in the vertical – up position

- The root pass in the vertical–up position starts from the end of the overhead position and is carried on up to the point shown in the figure below.

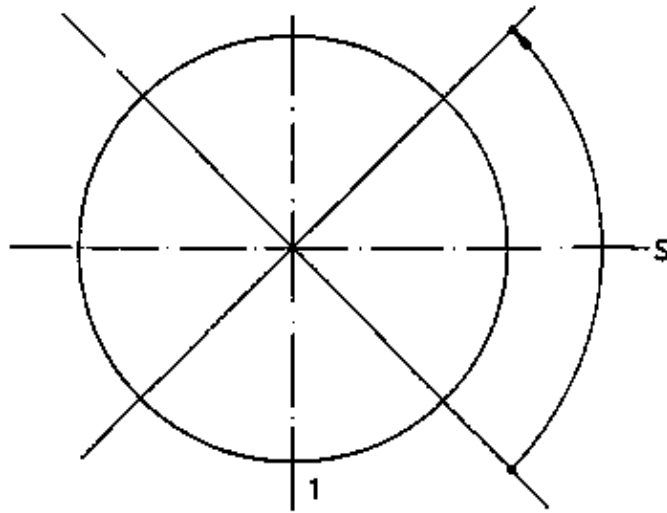

**1 - overhead position**  
**s - vertical-up position**

Fig. 21. Welding sequence in the vertical-up position

– The electrode should be guided in the same way as described vertical-up V type welding.

Welding the root pass in the gravity position

– The root pass in the gravity position starts at the end of the vertical-up position and is carried on to the tack No. 3. Beyond this point the weld is carried out from the point shown in the figure below up to the tack No. 3.

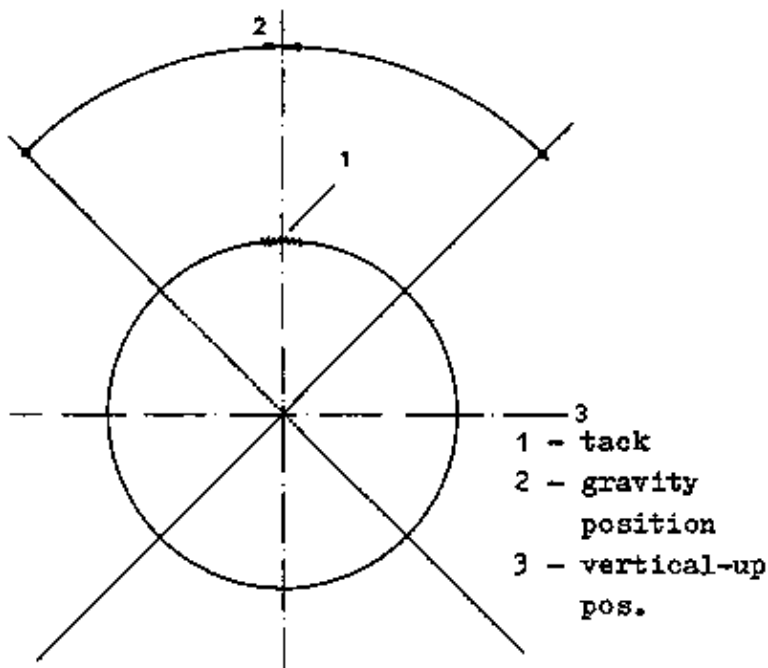
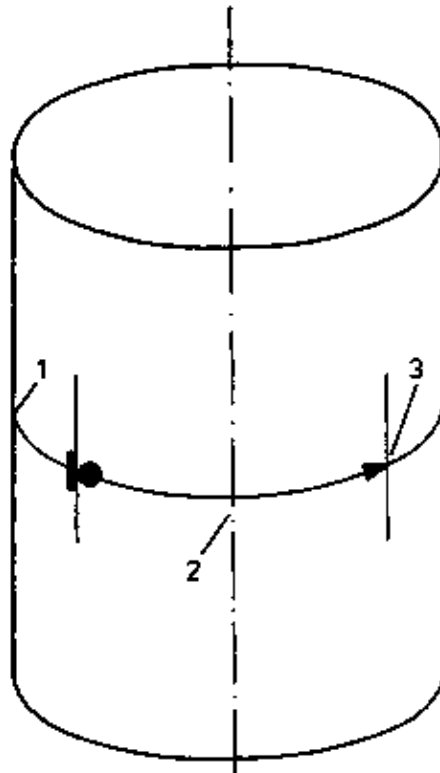

Fig. 22. Welding sequence for the gravity position 1 – Tack No. 3

– Welding the root in the gravity position is done with the same way of electrode guiding as used in gravity V type welding.

Welding the root pass in the horizontal-vertical position

– Unclamp the pipe from the positioning fixture and place it on the welding table so that the pipe axis is vertical.



- 1 - gravity position
- 2 - horizontal-vertical position
- 3 - overhead position

Fig. 23. Welding sequence for the horizontal-vertical position

- The transverse seam is welded on the remaining third of the pipe circumference.
- The electrode manipulation corresponds to that described in connection with horizontal-vertical V type welding.

After the root welding has been finished, the V type weld is carefully cleaned from slag and weld spatter. Check the root weld for possible welding faults such as insufficient through - welding, root sagging, arc strike faults, porosity, slag inclusions, lack of fusion and undercutting. Possible irregularities in arc strike areas should be removed using hammer and chisel. Discuss the welding faults with the trainees. Demonstrate perfect and faulty root welds. Let the trainees find out the causes of faulty welds and their elimination.

#### 4.3.2. Welding the inner passes

Demonstrate the welding of the inner passes to the trainees. For welding the inner passes, the instructions given for V type welding in the horizontal-vertical, gravity and vertical - up positions are also applicable. For welding in the overhead positions, the instructions given for the vertical-up position hold analogously, i.e. weaving of the electrode and dwelling at the side walls of the seam is also applicable in this case.

Point out to the trainees that the welding sequence shown in the figure below should be followed.

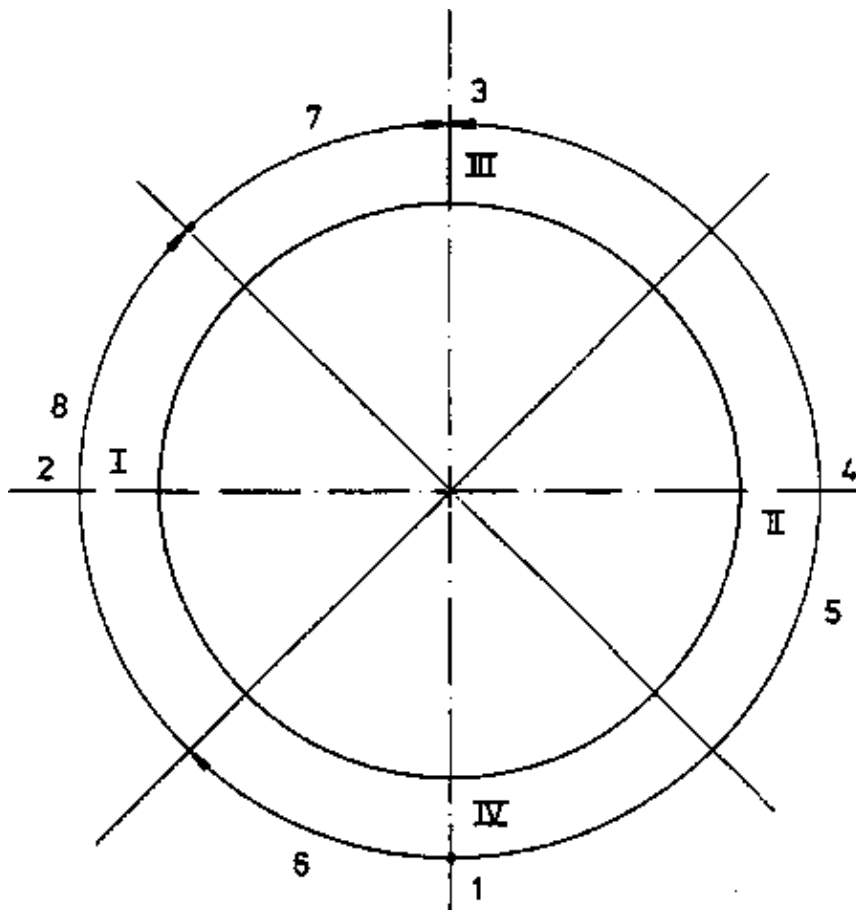

**Positions:**

- 1 - overhead
- 2 - horizontal-vertical
- 3 - gravity
- 4 - vertical-up
- 5 - 8 welding sequence

Fig. 24. Welding sequence for welding the inner passes I – IV – tacks 1 – 4

- Starting from tack No. 4, weld the inner pass at one stretch up to tack Ho. 3.
- From tack No. 4, weld towards the starting point of the transverse seam.
- Finally carry out the weld segment in the gravity position from the starting point of the transverse seam to tack No. 3.
- Thereafter place the pipe on the welding table so that the pipe axis is vertical. Now the welding of all the inner passes in the horizontal-vertical position is completed. Take care that the weld metal deposit is still appr. 1 mm below the outer surface of the pipe wall.
- With the pipe axis being horizontal, the pipe is filled up in the overhead, vertical-up and gravity positions so that the cover pass can be welded.
- For the inner passes welded in the overhead, vertical – up and gravity positions, the weld metal deposit shall also be appr. 1 mm below the outer surface of the pipe wall.

This measure yields a good orientation in welding the cover pass.

- In addition, take care that the arc strikes of the individual passes are always staggered by at least 20 mm. This always results in proper and faultless arc strikes.

After the inner passes have been completed, the pipe weld is carefully cleaned from slag residues and spatter. Check the uniformity of the uppermost inner pass. Unevennesses should be smoothed out by chipping. Draw the trainees' attention to the fact that a successful welding of the cover pass essentially depends on the appearance of the uppermost inner pass.

#### 4.3.3. Welding the cover passes

Demonstrate the welding of the cover passes to the trainees. The welding sequence can be observed, from the figure below.

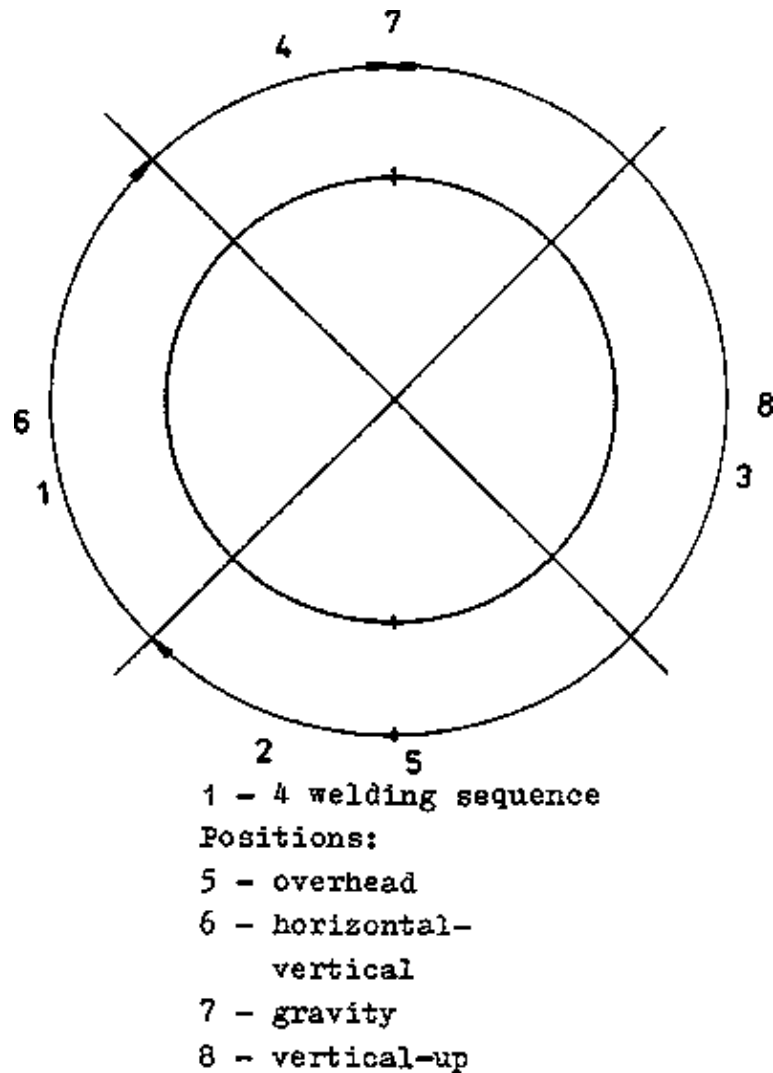

Fig. 25. Welding sequence of the cover pass

It is recommended first to weld the cover pass in the horizontal-vertical position.

The welding sequence and the weld buildup correspond to that of the V type weld in the horizontal-vertical position. The arc strikes and the end crater of the cover pass should slightly be ground off in order to achieve a proper arc strike for the subsequent cover passes in the overhead and gravity positions.

Now section 2 is welded in the overhead position.

The overhead position requires the same electrode - manipulation as it should be known from vertical-up welding.

Thereafter section 3 is welded in the overhead, vertical-up and gravity positions.

Finally section 4 is welded in the gravity position.

After the welding has been finished, clean the pipe weld and check it for welding faults.

#### 4.4. Evaluation of the finished pipe butt weld

Evaluate the finished pipe butt weld together with the trainees. Inform them of the criteria of evaluation. Evaluate the weld appearance (cover pass and root pass), the accuracy to size and the fracture appearance (horizontal-vertical, vertical-up and gravity positions). Evaluate the weld appearance by the following criteria:

- Uniformity of bead ripples
- Root appearance
- Arc strikes
- End craters
- Undercutting
- Spatter

##### Accuracy to size

Using a weld gage, determine three measuring points for each welding position. Demonstrate the checking for accuracy to size by means of the weld gage.

Inform the trainees of the following permissible weld reinforcements:

- Gravity position – 0 mm; + 1.5 mm
- Vertical-up position – 0 mm; + 2.5 mm
- Overhead position – 0 mm; + 2.5 mm
- Horizontal-vertical position – 0 mm; + 2.5 mm

##### Fracture appearance

The test specification requires that for the gravity, vertical-up and horizontal-vertical positions a 40 mm wide strip of material shall be taken and fractured.

Such test strips shall be prepared by flame cutting.

The positions from which test strips shall be taken can be observed from the figure below.

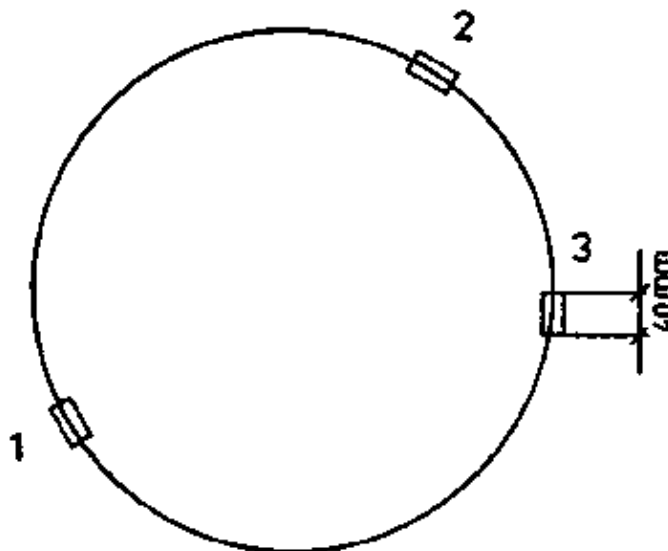

Fig. 26. Taking of test strips

Notch, and fracture the test strips to evaluate the fracture appearance.

- The V type weld is notched by planing – in.

Note that the notch is acute-angled and at least 4 mm deep.

## Evaluation of the Section "Pipe butt welding"

Having finished the training section of pipe butt welding, the trainees should have acquired the following knowledge, capabilities and skills:

- Obeying the labour safety regulations including order and cleanliness at the working place
- Preparation of the pipe
- Mastering all of the pipe welding positions
- Recognition of typical welding faults in pipe butt welds
- Evaluation of their own work

## Examples of questions on the Section "Pipe butt welding"

1. Explain the subdivision of the pipe by the four welding positions.
2. Describe the welding sequence for a pipe butt weld.
3. What are the special labour safety measures to be taken by the weldor in pipe butt welding?
4. What are the permissible weld reinforcements in pipe butt welding?

## **5. Guidelines for the examination**

After completion of the electric welding course, it is necessary that the trainees undergo an examination. This section will describe guidelines for carrying out such examination. These guidelines should be adapted to the conditions and regulations specific to the respective country.

These guidelines are applicable to the examination of electric arc weldors who carry out execution class III welding operations on carbon steels and low-alloy steels suitable for welding. These guidelines are also applicable to execution class III circumferential seam welding operations on steel piping, provided that the basic examination includes pipe welding tests.

### **5.1. Designation of the examination**

The examination should be designated by symbols according to the following table and entered into the certificate of qualification.

Welding technique	Type of examination	Thickness of work-piece up to 3 mm above 3 mm	
		a	b
Electric welding	B for basic examination without pipe specimen	a	b
	R for basic examination with pipe specimen		

Execution class III entitles the weldor to weld structural steels with a maximum carbon- content of 0.22 %. Welding alloyed low – alloy steels or steels sensitive to upgrading is not permitted.

### **5.2. Admission to the examination, welding permit**

All trainees who have successfully passed through the Electric Welding course (Methodical Instructions) are admitted to the examination.

The examination entitles the trainees to carry out class III welding operations by the welding technique in which the examination has been passed. The examinations of subgroup b exclude those of subgroup a, and the R basic examination includes the B basic examination for the same welding technique.

### 5.3. Execution of the examination

The examination consists of a practical and a theoretical part.

#### 5.3.1. Practical examination

The specimens for the basic examinations in electric welding shall be welded according to the following tables in the presence of the examining body. The thickness of the fillet welds shall be specified by the examining body, depending on the welding technique.

The examining body may decide to demand an additional specimen which corresponds to the special requirements of the respective factory or branch of industry.

Steel grades with strength values between those of St 34 and St 52 shall be used for the specimens. The specimens shall be at least 200 mm long.

Specimens for the basic Rb or Bb examination in electric welding

Type of exam. & specimen No.		Type of weld	Welding positions	Thickness of work-piece (mm)
RB	Bb			
1	1	fillet weld, root pass and 2 cover passes	horizontal	
2	2	V type weld	gravity	
3	3	fillet weld, root and cover pass	vertical – up	
4	4	V type weld	vertical – up	6 to 12
5	5	V type welds, 5 tacks appr. 30 mm long	3 x gravity 2 x vertical–up	
6	6	profile junction, root and 2 cover passes	horizontal	
7	7	fillet weld, root and 2 cover passes	semioverhead	
8 <sup>+3)</sup>	–	pipe butt weld, 1/4 of pipe axis vertical	horizontal–vertical	5 to 12
		pipe butt weld, 3/4 of pipe axis horizontal	overhead, vertical–up, gravity	
–	8	V type weld	horizontal–vertical	6 to 12

#### 5.3.2. Theoretical examination

The theoretical examination is carried out as a programmed examination. This means that the questions and the answers offered are presented to the trainee in writing. For each of the questions, three answers marked by 1, 2 and 3 are offered, one or two of which are correct, the others being wrong. On the answer sheet, the divisions of which correspond to the answers offered, the trainee shall mark off the correct answers by crosses. He has 50 minutes available to answer the questions.

The trainee may cancel wrongly entered crosses by hatching the whole division. The trainee should be informed of the system and the evaluation of the examination.

Compilation of the questions



The examiner compiles 50 questions from a given list. In the selection, the following proportions should be maintained:

- appr. 30 % about material science
- appr. 30 % about electric welding
- appr. 10 % about groove preparation
- appr. 10 % about welding sequences
- appr. 20 % about health protection, labour safety and fire protection

### Evaluation of the answer sheet

Every question to which answers are given shall be evaluated separately. Correct answers score + 1 each, negative answers score – 1 each. The plus and minus marks gained for the answer to one question are set off against each other. However, negative results for one question score 0. If three answers to one question have been marked off, then the score is 0. The sum of the scores calculated for each question gives the total score achieved.

$$\frac{\text{achieved total score} \cdot 100}{\text{maximum possible score}} = \text{achieved percentage of correct answers possible}$$

The ratings of percent scores achieved are calculated as follows:

- 100 ... 96 % = mark 1
- 95 ... 81 % = mark 2
- 80 ... 61 % = mark 3
- 60 ... 45 % = mark 4
- 44 ... 0 % = mark 5

Evaluation example for 10 questions with 13 correct answers symbolized by 0

Question No.	Answer No.			Calculated score
	1	2	3	
1		x		1
2	0		x	0
3		x	x	2
4	x	0		0
5	x			1
6	x	x	x	0
7		0		0
8	x			1
9		x	0	0
10	x	0		1
achieved score				6

$$\frac{6}{13} \cdot 100\% = 46.2\% = \text{mark 4}$$

#### 1. Materials science

1.1. Which type of steel melting causes a limited suitability for fusion welding?

1. Open–hearth process
2. Thomas Gilchrist process
3. LD process

1.2. What do you understand by the steel fining process?

1. Casting the steel melt into ingot moulds
2. Processing pig iron to steel under the action of oxygen
3. The melting process in the blast furnace

1.3. What are the detrimental properties of Thomas–Gilchrist steel?

1. Sensitivity to hardening
2. Sensitivity to ageing
3. Cold brittleness

1.4. Which element is added to the steel melt for deoxidation?

1. O<sub>2</sub>
2. S
3. Si

1.5. Which elements are – apart from O<sub>2</sub> – bonded by the deoxidants Mn, Si and Al?

1. P and C
2. S and N<sub>2</sub>
3. H<sub>2</sub> and C

1.6. Which elements cause the limited suitability for welding of Thomas–Gilchrist steel?

1. P
2. Si
3. N<sub>2</sub>

1.7. Which element, if contained in steel, effects red shortness?

1. N<sub>2</sub>
2. S
3. P

1.8. Why is sulphur an undesirable impurity in steel?

1. It causes red shortness.
2. It accumulates in the core zone of unkilld steels.
3. It causes cold brittleness.

1.9. Which element causes cold brittleness in steel?

1. S
2. P
3. Si

1.10. What is the effect of phosphorus in steel?

1. Red shortness
2. Embrittlement due to ageing
3. Cold brittleness

1.11. What is the value to which the phosphorus content must be reduced in carbon steels for welded structures?

1. 0.006 %
2. 0.080 %
3. 0.060 %

1.12. What are the changes in steel properties caused by an increasing carbon content?

1. It increases the tensile strength.
2. It reduces the elongation.
3. It increases the elongation.

1.13. Which alloying element causes the least reduction in elongation in addition to an increase in strength of carbon steel?

1. C
2. Si
3. Mn

1.14. What is the percent carbon content which must not be exceeded for a steel to be fully suitable for fusion welding?

1. 0.02 %
2. 0.22 %
3. 0.35 %

1.15. Why are steels preheated for welding?

1. To prevent red shortness
2. To achieve a martensitic structure in the heat-affected zone
3. To reduce the rate of cooling

1.16. What are the quantities the preheating temperature for welding depends upon?

1. C content
2. Percentage purity
3. Wall thickness

1.17. What are the possible causes of cracks in the welded joint?

1. Piling-up of seams
2. Preheating
3. Wrong welding sequence

1.18. Under what circumstances in welding can a 0.35 % C steel be expected to have a hardening structure?

1. Cooling in air
2. Cooling in air from the preheated condition
3. Furnace cooling after tempering at 700 °C

1.19. Which types of structure are undesirable in the welded joint?

1. Coarse-grain structure
2. Fine-grain structure
3. Hardening structure

1.20. What is the purpose to be achieved by stress-relief annealing?

1. Structural transformation
2. Elimination of deformations
3. Reduction of residual stresses

1.21. What requirements can only be met by normalizing?

1. A fine-grain structure with good tensile properties shall be achieved.
2. Stresses in the component shall be reduced.
3. Hardness peaks in the heat-affected zone shall be eliminated

1.22. What kind of structure is obtained in steel by normalizing?

1. Coarse-grain structure
2. Fine-grain ferrite-perlite structure
3. Cast structure with elongated crystallites

1.23. What are the temperatures at which normalizing is carried out?

1. 600... 650 °C
2. 30... 50 deg above GS
3. Below  $A_{c1}$

1.24. What are the temperatures required for stress-relief annealing?

1. 150... 350 °C
2. 250... 1100 °C
3. 600... 650 °C

1.25. Tell a practical method of cooling welded structures from 600 °C after normalizing.

1. In still air
2. In a furnace
3. By quenching

1.26. For what kinds of welded structures is it possible to use Thomas-Gilchrist steel?

1. Structures subjected to static loads
2. Structures subjected to shock-type loads
3. Structures which are loaded at low temperatures

2. Electric welding

2.1. Which effect of electric current is made use of in the welding generator?

1. Thermal effect
2. Magnetic effect
3. Chemical effect

2.2. Which effect of electric current is prejudicial to the welding process?

1. Welding converter
2. Welding transformer
3. Welding rectifier

2.3. Which welding power source has the highest efficiency?

1. Welding converter
2. Welding transformer
3. Welding rectifier

2.4. Which welding power source applies an asymmetric load to the mains?

1. Welding transformer
2. Welding converter
3. Welding rectifier

2.5. In which, respect can welding converters be considered advantageous?

1. Low open-circuit losses
2. High efficiency
3. Symmetric mains load

2.6. In which respect can welding transformers be considered advantageous?

1. Symmetric mains load
2. Low arc blow effect
3. Allows welding with B type electrodes

2.7. For which technique can the dropping volt-ampere characteristic be used?

1. Electric welding
2. MAG welding
3. WIG welding

2.8. For which technique is the nearly horizontal load characteristic suitable?

1. Electric welding
2. MAG welding
3. MIG welding

2.9. Why is the current density in electric welding lower than in MAG welding?

1. Because of the larger electrode diameter
2. Because of the exposed length of the electrode
3. Because of the dropping volt-ampere characteristic

2.10. What determines the welding voltage in electric welding?

1. Adjustment at the power source.
2. The volt-ampere characteristic of the power source.
3. The arc length

2.11. Which type of welding power source generates alternating current?

1. Welding converter
2. Welding rectifier
3. Welding transformer

2.12. Which type of welding power source generates direct current?

1. Welding converter
2. Welding rectifier
3. Welding transformer

2.13. Which welding amperage is required for a 4 mm electrode?

1. 160 A
2. 250 A
3. 120 A

2.14. Which welding power sources distinguish themselves by a low open-circuit power consumption, low noise and low maintenance cost?

1. Converters
2. Rectifiers
3. Transformers

2.15. Which power sources permit welding with all types of electrodes?

1. Converters
2. Rectifiers
3. Transformers

2.16. How do you weld with common B type electrodes?

1. Electrode at the positive pole
2. Electrode at the negative pose
3. a.c. welding

2.17. What measures can be taken to reduce energy losses in a welding equipment?

1. Shortening the welding cables
2. Reducing the cross section of the welding cables
3. Increasing the cross section of the welding cables

2.18. that is the direction of arc deflection due to the arc blow effect?

1. Towards the work clamp
2. Off the work clamp
3. Towards the larger steel body

2.19. What measures can be taken to counteract the arc blow effect?

1. Tilting the electrode in the direction of the arc blow effect
2. Tilting the electrode in the direction opposite to the arc blow effect
3. Using bifurcated poles

2.20. Under which conditions is it permissible to overweld cracked tacks?

1. Overwelding is forbidden in any case
2. It is permissible in execution class III
3. Overwelding is only permissible in fillet welding

2.21. What is the purpose of the electrode coating?

1. Protection from atmospheric moisture
2. Generation of shielding gas
3. Arc stabilization

2.22. Which electrode types cannot be a.c. welded?

1. Bare wire
2. A types
3. Certain B types

2.23. Can E type electrodes be a.c. welded?

1. Yes, all types
2. No
3. Yes, certain types

2.24. Which electrode types can be used in welding Thomas–Gilchrist steel?

1. A types
2. B types
3. Electrodes with very thick coatings

2.25. What is the thickness of coating of the E 43 4 RR (B) type electrode?

1. Thin coating
2. Very thick coating

3. Medium coating thickness

2.26. Describe the bridgeability of a E 43 2 R type electrode.

1. Poor
2. Good
3. Very good

2.27. How is the transfer of droplet of a B type electrode?

1. Fine droplets
2. Medium droplets
3. Coarse droplets

2.28. How can pore formation be prevented in electric welding?

1. By holding a longer arc
2. By predried electrodes
3. By a higher amperage

2.29. What are the possible mistakes in the drying of B type electrodes?

1. 2 hr at 250 °C
2. Drying the electrodes close stacked in a drying cabinet
3. Drying the electrodes spread out on a radiator

2.30. What are desirable effects of slag on the weld pool?

1. Formation of the weld surface and alloying of the weld metal
2. Generation of shielding gas
3. Reduction of the cooling rate

2.31. What imparts toughness together with a sufficient tensile strength to the weld metal?

1. Reducing the C content to 0.12 % and increasing the Mn content
2. Taking up oxygen and nitrogen from the atmosphere
3. C content up to 0.22 %

2.32. Which type of weld metal has the lowest concentration of oxygen, nitrogen and hydrogen?

1. Weld metal of the E 51 4 RR (B) type electrode
2. Weld metal of the E 43 0 A type electrode
3. Weld metal of the E 43 4 B type electrode

2.33. What is the effect of nitrogen on the weld metal?

1. Ageing embrittlement
2. Hot – cracking susceptibility
3. Susceptibility to pores

2.34. What are the quantities on which the ohmic resistance depends in the circuit?

1. The shape of section of the conductor
2. The wire length and the corss sectional area in mm<sup>2</sup>
3. The material

2.35. What is the execution class of welding operations permitted for a weldor who passed an elementary course examination?

1. Class II B
2. Class II A
3. Class III

2.36. What is the voltage across the phases R and T in a 220/380 V three-phase system?

1. 220 V
2. 380 V
3. 110 V

2.37. On which pole is the higher temperature generated in d.c. arc welding?

1. On the positive pole
2. On the negative pole
3. Equal temperatures on both the positive and the negative pole

2.38. What is the cause of the high temperatures at the arc strikes?

1. The impingement of electrons and ions
2. The thermal effect of the electric current
3. The ionization of the air gap

2.39. How can the weldor influence the thermal effect (depth of penetration) on the welded component?

1. By the arc length
2. By the manipulation and the position of the electrode
3. By the selection of the welding power source

2.40. What is the cause of the arc blow effect in welding?

1. The non – uniform heating-up of the welded component
2. The compression or expansion of the magnetic fields of force
3. Insufficient ionization of the arc gap

2.41. What is the use of a star-delta switch?

1. To reduce the cut-in current rush
2. To protect the generator winding from overload
3. To reduce the speed of the motor

2.42. What means the symbol "VC" on the rating plate of a welding power source?

1. The power source can be changed over between d.c. and a.c. operation.
2. The power source has a variable welding current range
3. The power source has a variable characteristic

2.43. What is the use of the field coil in the welding generator?

1. To increase the welding current
2. To build up a magnetic field of force
3. A.c.-to-d.c. conversion

2.44. How can the mains voltage be reduced to the welding voltage in a welding transformer?

1. By the primary-to-secondary turns ratio
2. By moving a stray core
3. By the dimensioning of the laminated iron core

2.45. What is the use of the rectifier set?

1. A fine-step variation of the welding current
2. Rectifying the line current
3. Rectifying the transformed three-phase current

2.46. What are the advantages of using a welding rectifier?



1. It permits welding with all electrode types.
2. Low open-circuit power consumption
3. Low prime cost

2.47. What demands are made upon B type electrodes?

1. Insensitivity to moisture
2. Suitability for d.c. and a.c. welding
3. Good mechanical property data of the weld metal

2.48. Which electrode type is most suitable for thin-sheet welding?

1. E 43 3A
2. E 43 4 RR(B)
3. E 43 2 R

2.49. Which electrode type is most resistant to cracking?

1. E 43 4 B
2. E 43 2 R
3. E 43 4 RR(B)

2.50. Up to which plate thickness can a square butt weld be electrically welded from one side?

1. 3 mm
2. 4 mm
3. 5 mm

2.51. Which shape of the fillet weld is most economical?

1. Flush weld
2. Concave weld
3. Reinforced weld

2.52. Which incorrect technique may be the cause of a lack of fusion in electric welding?

1. Too large an included angle
2. Too small an included angle
3. Too low amperage

3. Groove preparation

3.1. Given the task to electrically weld an St 42b-2 plate,  $s = 10$  mm, in the horizontal position. Which weld type is practical at butt joints?

1. Y type weld
2. V type weld
3. Square butt weld

3.2. Which, type of fillet weld is best suitable for the magnetic field pattern?

1. Flush weld
2. Concave weld
3. Reinforced weld

3.3. Which included angle do you choose for the V type weld?

1. 16 ... 24 °
2. 20 ... 40 ° – correct for MAG
3. 50 ... 60 ° – correct for electric welding

3.4. Which dimensional data are required for V type weld preparation?

1. Included angle
2. Root opening b
3. Web height c

4. Welding sequences

4.1. Why is it necessary to obey welding sequence schedules in the practice of welding?

1. To achieve short welding times
2. To minimize shrinkage and stresses
3. To save extra cost for straightening work

4.2. Which welding sequences are required to minimize the residual welding stresses in the welded component?

1. Tack the whole structure to be welded, thereafter carry out the welding
2. Finish-weld the individual components, thereafter join them into the welded structure
3. Prevent shrinkage by clamping

4.3. What determines the extent of shrinkage?

1. The heat input rate
2. The form of the groove
3. The C content of the base material

4.4. How can angular shrinkage in welding be counteracted?

1. By preheating
2. By tacking in a roof-like configuration
3. By increasing the number of weld passes

4.5. Which type of shrinkage results in high residual welding stresses in a 12 mm thick plate which is welded without clamping?

1. Longitudinal shrinkage.
2. Transverse shrinkage
3. Thickness shrinkage

4.6. What are the temperature ranges in which elastic stresses are caused by non – uniform cooling?

1. 500 ... 20 °C
2. 850 ... 600 °C
3. 1500 ... 850 °C

4.7. Under which conditions are high stresses likely to occur in the welded component?

1. No welding distortions
2. Minor welding distortions
3. Heavy welding distortions

4.8. Which type of shrinkage can be neglected for a 12 mm thick plate?

1. Longitudinal shrinkage
2. Thickness shrinkage
3. Transverse shrinkage

4.9. ON which quantities does the angular shrinkage of a V type weld depend?

1. Included angle
2. Number of passes
3. Length of the weld

5. Health protection and labour safety, fire protection

5.1. Which of the following operations can only be performed with a welding permit?

1. Welding of a sprocket in a welding shop on a welding table
2. Repair welding of a heating pipe in an office room
3. Welding of a container which contained inflammable materials

5.2. What is the minimum height of a workshop room which shall be used as a welding shop?

1. 3 m
2. 3.5 m
3. 4 m

5.3. Provided that the labour safety regulations are obeyed, are then welding jobs considered to be

1. of no consequence for the state of health of the weldor?
2. annoying?
3. dangerous?

5.4. What are MAK<sub>D</sub> values?

1. Concentration of harmful substances in the atmosphere
2. Concentration of non-explosive gas-air mixtures
3. Maximum welding amperages

5.5. During welding operations in containers, the breathing air deteriorates. What measures should be taken?

1. Supply of oxygen
2. Adequate exhaustion and ventilation with fresh air
3. Use of fresh-air respirators

5.6. When must a weldor wear a fresh – air respirator during welding operations?

1. When a long – distance gas pipeline is newly installed
2. During operations on galvanized or lead-coated weldments
3. When MAG<sub>D</sub> values are provably exceeded in the range of the working place

5.7. Which welding technique causes an intensive UV radiation?

1. Gas welding
2. MAG welding
3. Electric welding

5.8. Will UV radiation, in the case of insufficient protective measures, have harmful effects on

1. inner organs?
2. osseine?
3. the skin and the eyes?

5.9. What causes dangerously high open-circuit voltages?

1. Series connection of welding power sources
2. Parallel connection of welding power sources
3. Simultaneous work of several weldors on one and the same weldment (d.c. welding, equal polarity)

5.10. Which open-circuit voltage of the welding power sources is considered harmless for the human body under normal circumstances?

1. 42 V
2. 70 V
3. 100 V

5.11. Which welding power sources can be used in working areas with high electric danger coefficients, if fully insulated electrode holders are used?

1. 100 V welding converters
2. 70 V welding transformers
3. 60 V (peak voltage), 12 % ripple welding rectifiers

5.12. Which welding power sources can be used in working areas with a high electric danger coefficient, if no fully insulated electrode holders are used?

1. 42 V welding converters
2. 85 V (peak voltage), 12 % ripple welding rectifiers
3. 42 V welding transformers

5.13. To which point must a welding return wire be connected in the case of long welding leads?

1. To the structure to be welded with long return wires
2. To the steel structure of the welding workshop building with short return wires
3. To the frame of a swivelling gear which is not equipped with sliding contacts

5.14. In arc welding occur 3 types of beam. Which type of beam causes a dark inflammation of eyes and skin if the measures of protection are not sufficient?

1. light beam
2. heat beam (infrared beam)
3. ultraviolet beam

Answer sheet to the elementary examination for electric welding Examining board				Name: First name: Participant No.: Place, date:					
Technical theory				Health protection, labour safety, fire protection					
Question	Answer No.			Score	Question	Answer No.			Score
No.	1	2	3		No.	1	2	3	
Remarks:				100 ... 96 % = mark 1 95 ... 81 % = mark 2 80 ... 61 % = mark 3 60 ... 45 % = mark 4 44 ... 0 % = mark 5					
Technical theory				Examiner					
$\frac{\text{Obtainedscore}}{\text{possiblescore}} \cdot 100 = \dots \% = \text{mark}$									
Summary evaluation									
$\frac{\text{obtainedscore}}{\text{possiblescore}} \cdot 100 = \dots \% = \text{mark}$									
				(signature)					

## 5.4. Evaluation of the examination

### Practical examination

The members of the examining board should independently evaluate the test specimens for weld appearance, fracture appearance and accuracy to size. The marks should be entered into the evaluation sheet.

The evaluation of the fracture appearance is not applicable to specimens with work thicknesses of mm. For fracture evaluation, the raw samples should be taken by flame cutting over a width of 40 mm each from weldments carried out in the gravity, vertical–up and horizontal–vertical positions. The evaluation marks can be read from the following table:

Marks	Demands
1 very good	Perfect weld of faultless appearance. Full accuracy to size. Weld–metal – base metal interface entirely free of undercutting. Uniform fusion at the root of the weld. Unobjectionable fracture appearance.
2 good	Weld appearance with minor irregularity and inconsiderable undercutting. Variations in size for fillet welds up to appr. 30 % of the permissible tolerance. Uniform root fusion with inconsiderable irregularities at the arc strikes. Fracture appearance with minor porosity.
3 satisfactory	Weld appearance with irregularities and undercutting, which has no effect on the strength of the weld. Variations in size for fillet welds up to 60 % of the permissible tolerance. Root reinforcement irregular, but full fusion of the root. Fracture appearance with minor slag and medium porosity.
4 fairly satisfactory	Weld appearance with irregularities and edge undercuts, which are not, however, considered to require repair work. Variations in size for fillet welds up to the full permissible tolerance according to the table of weld tolerances. Root fusion over at least 80 % of the length of the specimen. Fracture appearance with isolated larger pores and slags, but without slag lines and slag pockets.
5 unsatisfactory	Weld appearance with irregularities and edge undercuts requiring repair work. Variations in size exceeding the permissible tolerance. Root fusion over less than 80 % of the length of the specimen. Fracture appearance showing porosity with larger faults.

### Permissible weld tolerances

Welding technique	Weld thickness	Welding position	Weld reinforcement <sup>9)</sup> for butt welds	Variation in the weld thickness for fillet welds
	up to 6		1	
E		gravity horizontal, vertical–down		+ 1.0
	more than 6	–0.5	2	
	arbitrary	vertical–up, overhead, horizontal–vertical	3	+ 2.0
		all positions		– 0.5

<sup>9)</sup> Applicable to cover pass and root

The evaluation sheet summarizing the results of the examination should be signed by all members of the examining board.

