

➔ **Working on Grinding Machines (Institut fr Berufliche Entwicklung, 10 p.)**

(introduction...)

- 1. The Purpose of Grinding on a Belt Grinding Machine**
- 2. Construction of a Belt Grinding Machine**
- 3. The Grinding Tools**
- 4. The Operation of a Belt Grinding Machine**
- 5. The Technological Processes of Grinding**
 - 5.1. Setting up the Belt Grinding Machine**
 - 5.2. Grinding of Wide Surface**

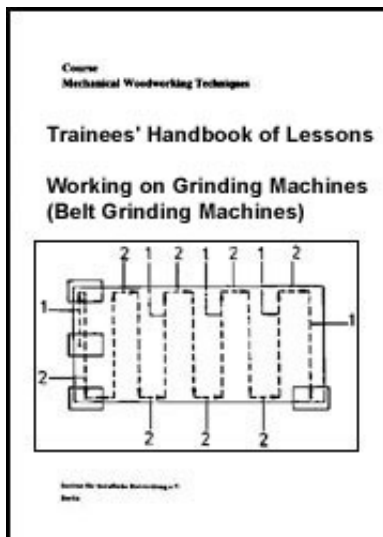

➔ **Working on Grinding Machines (Institut fr Berufliche Entwicklung, 10 p.)**

(introduction...)

- 1. The Purpose of Grinding on a Belt Grinding Machine**
- 2. Construction of a Belt Grinding Machine**
- 3. The Grinding Tools**
- 4. The Operation of a Belt Grinding Machine**
- 5. The Technological Processes of Grinding**

**Institut fr berufliche Entwicklung e.V.
Berlin**

**Original title:
Arbeitsmaterial fr den Lernenden
"Arbeiten an Schleifmaschinen (Bandschleifmaschinen)"**

Author: Johannes Schollbach

First Edition © IBE

**Institut fr berufliche Entwicklung e.V.
Parkstrae 23
13187 Berlin**

Order No.: 93-35-3407/2



[Home](#) > [ar.cn.de.en.es.fr.id.it.ph.po.ru.sw](#)

 **Working on Grinding Machines (Institut fr Berufliche Entwicklung, 10 p.)**

 **(introduction...)**

  **1. The Purpose of Grinding on a Belt Grinding Machine**

 **2. Construction of a Belt Grinding Machine**

 **3. The Grinding Tools**



4. The Operation of a Belt Grinding Machine

5. The Technological Processes of Grinding

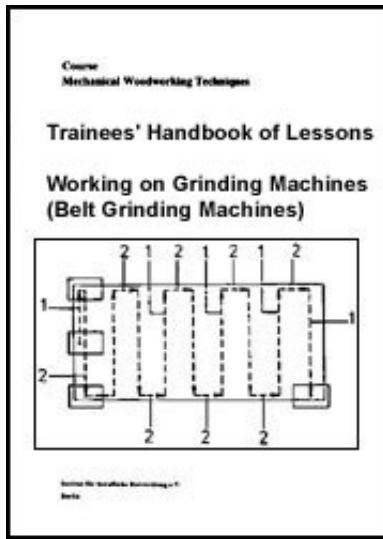

1. The Purpose of Grinding on a Belt Grinding Machine

Belt grinding machines are grinding machines for wood-working which grinding tools are an endless sand belt. They are applied for:

- **Thickness grinding and roughing up of wide surfaces of support plates to be stuck with veneer or foils.**
- **Polishing of wide surfaces of solid wood and chip boards for further surface treatment.**
- **Polishing of veneered wide surface.**

There are several types of belt grinding machines. The classification is done according to different points of view, e.g. according to the position of the sand belt.

What is the purpose of grinding on a belt grinding machine?



[Home](#) > [ar](#).[cn](#).[de](#).[en](#).[es](#).[fr](#).[id](#).[it](#).[ph](#).[po](#).[ru](#).[sw](#)

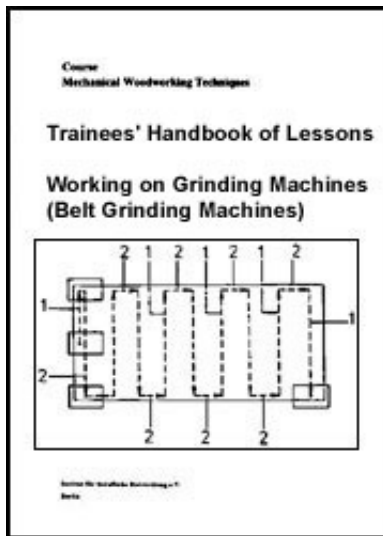

Working on Grinding Machines (Institut fr Berufliche Entwicklung, 10 p.)

 (*introduction...*)

 **1. The Purpose of Grinding on a Belt Grinding Machine**

 **➔ 2. Construction of a Belt Grinding Machine**

 **3. The Grinding Tools**

 **4. The Operation of a Belt Grinding Machine**

 **5. The Technological Processes of Grinding**

2. Construction of a Belt Grinding Machine

The construction of a belt grinding machine is explained on the example of a horizontal belt grinding machine as follows.

The horizontal belt grinding machine is a belt grinding machine with a horizontal flat belt run.

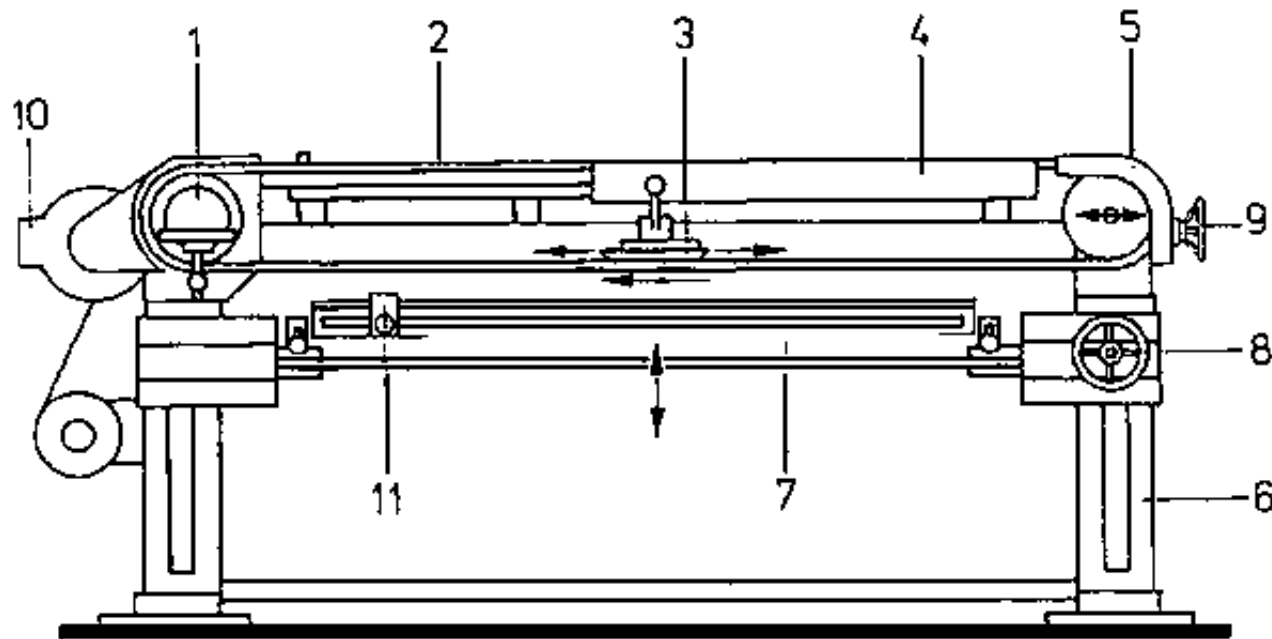

Figure 1 - Construction of the belt grinding machine

1 sand belt roller, 2 sand belt, 3 pressure shoe, 4 cover of the sand belt, 5 covering of the belt rollers, 6 stands, 7 sliding table, 8 hand wheel for fixing the height of the sliding table, 9 hand wheel for fixing the tension of the sand belt, 10 abrasive dust exhaustion, 11 stop bar

The construction includes:

The stands

Two grey cast iron stands are fast screwed together by rails. Between the two stands run the vertically adjustable sliding table and the pressure shoe on round bars. The motor with the driven belt roller is rigidly fastened on the left stand. The second belt roller for fixing the sand belt runs on bearings of the right stand.

The sliding table

The sliding table moves on round bars transverse the sand belt.

Depending on the thickness of the piece of work it is adjustable in height by a hand wheel (see Fig. 1).

Lockable recesses for grindig box shaped pieces of work are manufactured in the sliding table.

The pressure shoe

The pressure shoe is carried in pendulum bearings and movable along the sand belt.

Grinding felt is sticked to the sole of the pressure shoe. Because of the swinging bearing the grinding felt adapts to the surface of the piece of work.

Safety devices

The covering of the belt rollers and the cover of the upper free belt run belong to them.

Which belt roller runs on bearing?

Why does this belt roller run on bearings?

Why is the sliding table adjustable in height?

Why is the pressure shoe carried in pendulum bearings?



[Home](#) > [ar](#).[cn](#).[de](#).[en](#).[es](#).[fr](#).[id](#).[it](#).[ph](#).[po](#).[ru](#).[sw](#)

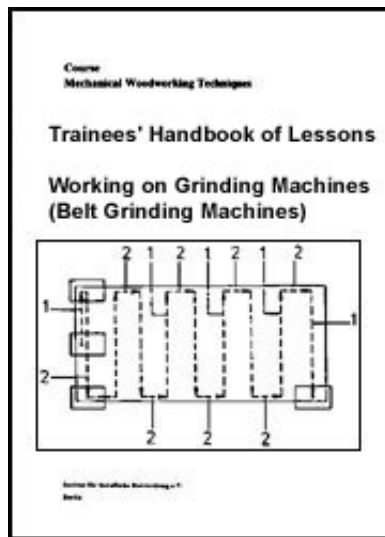

 **Working on Grinding Machines (Institut fr Berufliche Entwicklung, 10 p.)**

 **(introduction...)**

 **1. The Purpose of Grinding on a Belt Grinding Machine**

 **2. Construction of a Belt Grinding Machine**

 **3. The Grinding Tools**

 **4. The Operation of a Belt Grinding Machine**

 **5. The Technological Processes of Grinding**

3. The Grinding Tools

The sand belt is a bendable grinding tool.

It consists of:

The support (support material)

The support is coated with glue which takes up the abrasive grains. It has a high stability and bendability in order to resist the strains during the grinding process.

Binding agent (glue)

The binding agent serves to stick the abrasive to the support.

The abrasives

The abrasives are shaped edged, mineral or synthetic abrasive tools of different size and hardness. The abrasive carries out the cutting process. There are abrasives of different type and grain size.

According to the grain size different grain groups are distinguished.

The maximum size of the abrasive grains is indicated in 1/100 mm.

grain group	indication of the graining
fine	16
	20
	25
medium	32

	40
	50
coarse	80
	100
	125

The sand belt is roller ware with a roller width of 120 mm to 200 mm. It is cut to the necessary length and fixed together as a transverse or tooth shaped joint. The joint will be stuck on the back with solid thin cloth.

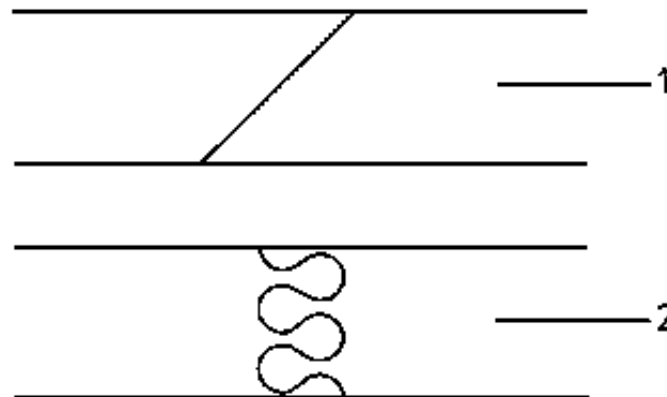

Figure 2 - Sand belt joining

1 transverse glued joint

2 tooth shaped joint

The sand belt should be stored dry. The belts should not be bent or teared on the edges.

The abrasive type and the graining are printed on the sand belt, e.g. NK 32, NK = normal corundum, 32 = medium grain group.

The sand belt must be covered at the belt rollers and at the front edge of the upper belt run.

What does the sand belt consist of?

What types of abrasives are there to be found?

How is the sand belt fixed to an endless belt?



[Home](#) > [ar.cn.de.en.es.fr.id.it.ph.po.ru.sw](#)

 **Working on Grinding Machines (Institut fr Berufliche
Entwicklung, 10 p.)**



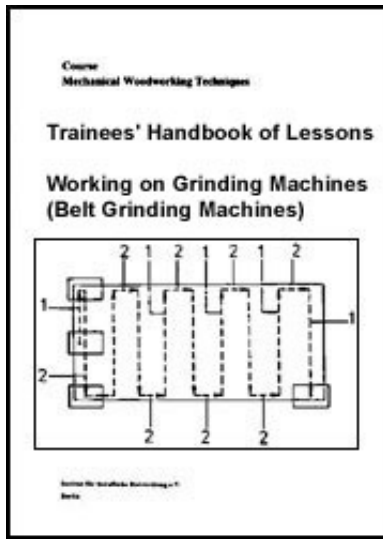

(introduction...)

-  **1. The Purpose of Grinding on a Belt Grinding Machine**
-  **2. Construction of a Belt Grinding Machine**
-  **3. The Grinding Tools**
-   **4. The Operation of a Belt Grinding Machine**
-  **5. The Technological Processes of Grinding**

4. The Operation of a Belt Grinding Machine

The sand belt is put into straight-lined motion by the motor over the belt roller.

The sand belt is pressed on the piece of work by the pressure shoe. Thereby the abrasive grains remove very fine shavings in form of abrasive dust from the piece of work. Because of the movability of the grinding table and the pressure shoe all parts of the surface of the piece of work are reachable.

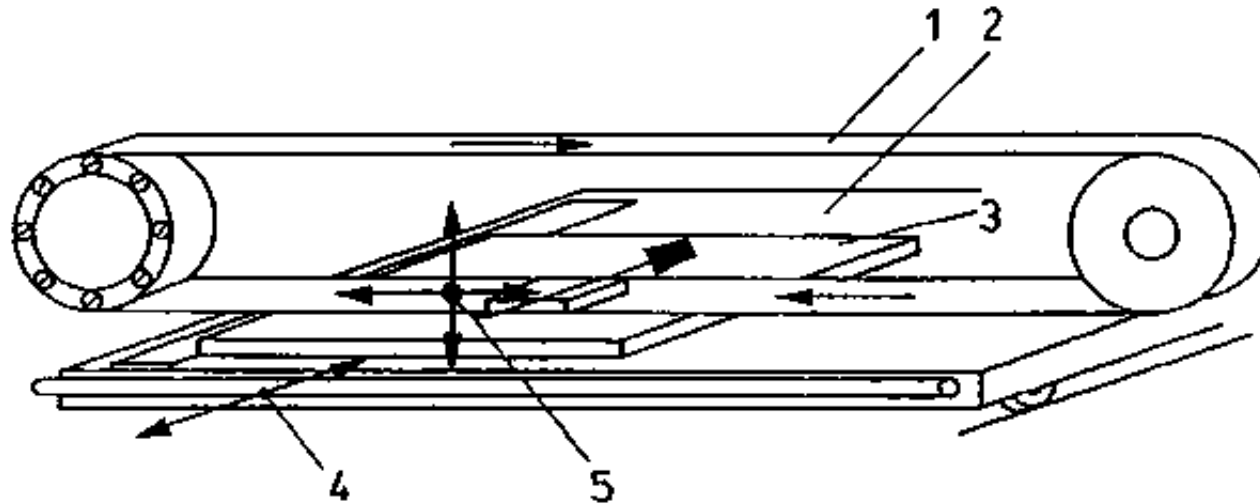

Figure 3

1 sand belt with indication of running direction, 2 machine table, 3 piece of work, 4 hand grip on the machine table, 5 ball grip on the pressure shoe



[Home](#) > [ar.cn.de.en.es.fr.id.it.ph.po.ru.sw](#)

 **Working on Grinding Machines (Institut fr Berufliche Entwicklung, 10 p.)**

 **5. The Technological Processes of Grinding**

 **5.1. Setting up the Belt Grinding Machine**

 **5.2. Grinding of Wide Surface**

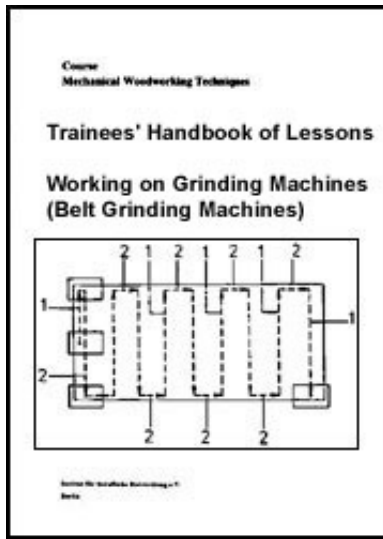

Working on Grinding Machines (Institut fr Berufliche Entwicklung, 10 p.)

5. The Technological Processes of Grinding

5.1. Setting up the Belt Grinding Machine

The grinding machine is clean and without current (the mains are switched-off). The safety devices are removed. The required sand belt is placed on the belt roller carefully, in order not to damage the edges. With the hand wheel the necessary belt tension is adjusted. The belt should be able to be pressed only slightly.

All safety devices are fixed according to the directions. The coverings of the belt rollers and the cover of the upper free belt run belong to it.

In a short test run the running of the sand belt is checked. A run off center belt is adjusted by means of the belt running correction.

Now the machine table can be adjusted in the right height. Thus the piece of work is placed on the sliding table and driven under the sand belt. The right table height is reached if between sand belt and the piece of work are 5 mm of space.

Via the selection switch the running direction of the sand belt is adjusted. By switching on the exhaust device the machine is ready to use.

5.2. Grinding of Wide Surface

The piece of work is placed on the machine table, adjusted and set to the stop bar. For different processes it is possible to make the coarse grinding across the grain. Thus the surface first is evened up. The following length grinding is mainly for smoothing. The co-ordinated movement of the left and the right hand is important with grinding.

The left hand takes the grip bar of the machine table and carries through the to and from movement. The right hand takes the grip of the pressure shoe.

By the movement of the grinding table and the pressure shoe every part of the surface can be treated. You should pay attention that the pressure shoe is not guided too far over the edges in order to avoid a toppling over.

Guide the pressure shoe under constant pressure over the surface. Thus the grinded material is cut evenly and an even surface is reached.

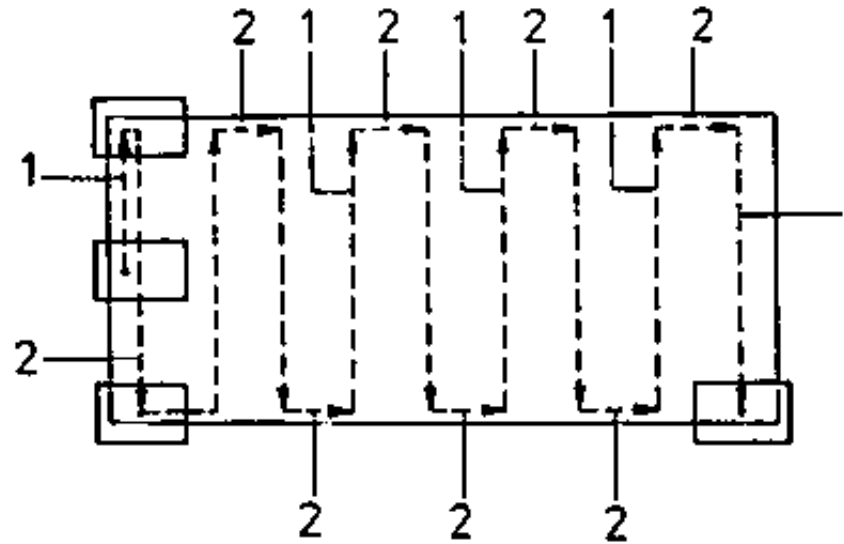

Figure 4 - Technology of grinding - cross feed

1 movement of the left hand (machine table)

2 movement of the right hand

With the grinding of support plates for a further sticking with veneer you will grind with a coarse sand belt lengthwise and transverse.

With the grinding of solid wood and veneered surfaces you first grind with a medium sand belt and then with a fine one. These two grindings are carried out with the grain. With the grinding traces of former working stages are removed and a smooth surface is reached. Quality control is carried out visually and by rubbing gently with the hand over the surface of the piece of work.

You must pay attention that the table guiding hand should not get into the area of the sand belt.

The pressure shoe should lift up itself when not in use.

The recesses on the table should be closed after being used.

- The abrasive dust should be exhausted separately from the shavings and stored separately.**
- No metallic objects should be ground on the machine because of the sparking there can occur explosion fire danger.**

Which safety devices are situated on the belt grinding machine?

How is the quality control of the ground pieces of work carried out?

