



Carpentry for Vocational Schools - A Teacher's handbook (GTZ, 252 p.)

5. FOOTINGS

 **(introduction...)**

 **5.1. Correct depth and shape**

 **5.2. Piers or stumps**

 **5.3. Correct embedding of piers or stumps**

 **5.4. Finish**

 **5.5. Strip footing on concrete block wall**

 **5.6. Control joints for concrete block wall**

 **5.7. Applying mortar to a block**

 **5.8. Strip footing on masonry (concrete) wall**

 **5.9. Different types of strip footing**

Carpentry for Vocational Schools - A Teacher's handbook (GTZ, 252 p.)

5. FOOTINGS

TOPIC: 5. FOOTINGS

INTRODUCTION: There are a lot of different types of footings Each one has its own function and there are only few things which they have in common.

The aim of this section is to teach students how to make proper footings and identify the different types of footings.

OBJECTIVES:

- 5.1. Students must know the purpose of a footing and its correct depth and shape.**
- 5.2. Students must be able to identify the different types of post or stumps and their characteristics.**
- 5.3. Students should know how stumps or posts are embedded correctly in the concrete to prevent them from sinking into the ground.**
- 5.4. Students have to know how to finish the top of the concrete surrounding a post or stump.**
- 5.5. Students should be able to describe a strip footing for a concrete block wall, how it is reinforced and the mixture of the concrete used.**
- 5.6. Students should be able to state the names of the different control joints and why it is necessary to make control joints.**
- 5.7. Students should know the correct procedure for laying concrete blocks.**
- 5.8. Students should be able to describe a strip footing for a masonry wall and the measurements for placing the reinforcement bars and mesh.**

5.9. Students must know the different types of strip footing and how they are correctly reinforced.

METHOD: We prepare photocopies of the different footings which are handed out to students after the lesson in the classroom and are glued into the students trade theory book.

Also this topic might be difficult to demonstrate. If there are not enough resources and there are no on-going building projects to work on, models of different footings in the scale of 1:10 can be made for demonstration to give the students a better understanding of this very important work.

NOTE: At the end of this topic again a worksheet can be prepared which students fill in their own time for further reinforcement of this subject and is assessed later.

The footings are carrying the weight of the building and it is therefore very important that footings are made deep enough in the soil, firm enough to carry the weight without sinking.

5.1. Correct depth and shape

a) Depth:

- If the site has been back filled you must dig the footing deep enough to go to a minimum of 550 mm into firm soil.**

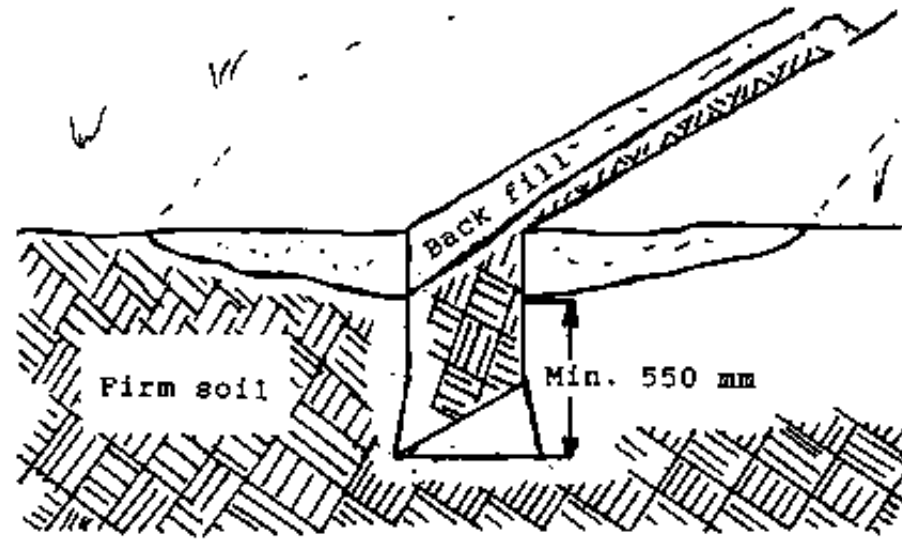

Figure

- On undisturbed or excavated sites the depth of the footing is 550 mm minimum.

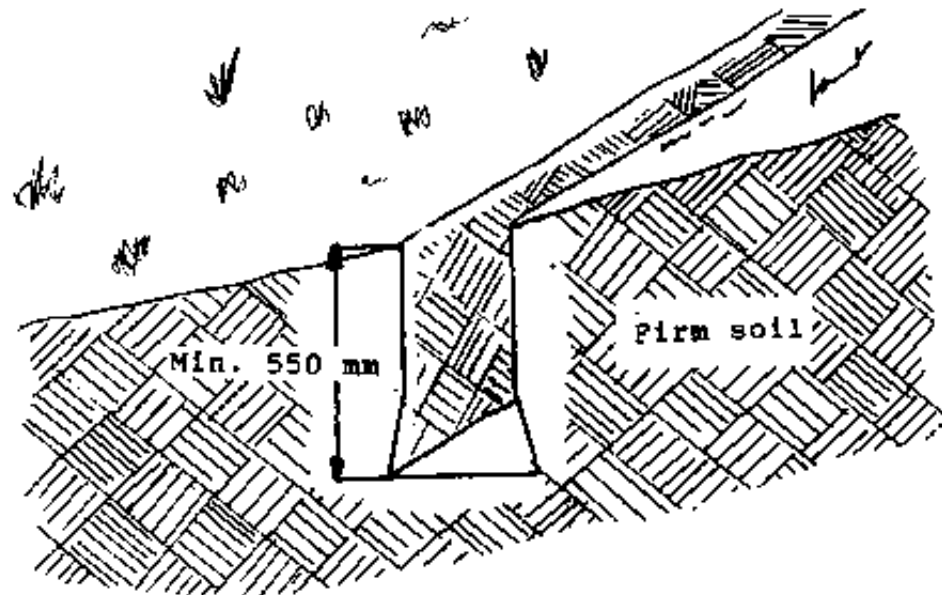

Figure

b) Shape:

- As the area of the bottom of the footing determines the weight it can carry without sinking, the shape of it is very important. If the shape of a footing is like a wedge, it will easily sink into the ground.

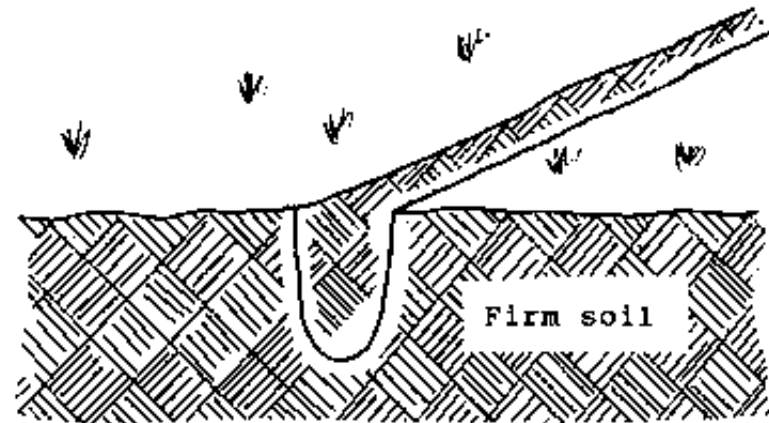

Figure

- The correct shape of a footing should be wider at the bottom of the footing than at the top.

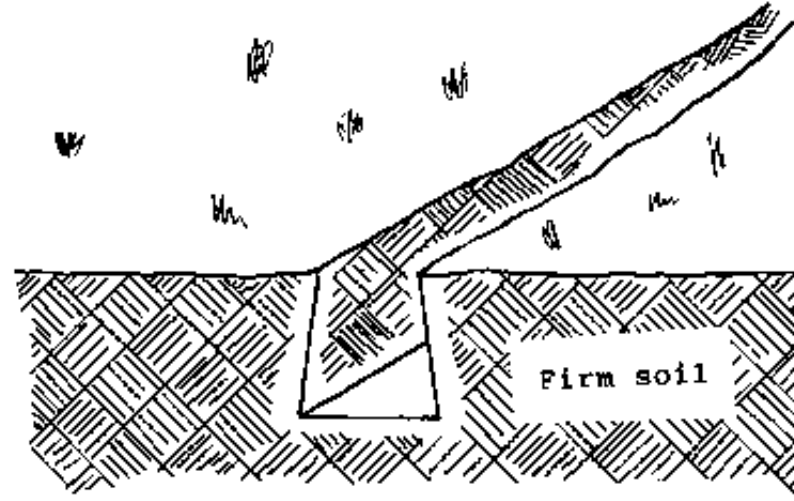

Figure

5.2. Piers or stumps

Piers or stumps can be made of iron posts, treated timber posts or concrete. Tall piers or stumps must be braced.

a) Iron posts: - The diameter of the iron post depends on the number of piers or stumps per square metre, number of stories and the height of floor level above ground level. Angle iron has to be welded on top and steel rods must be welded at the lower part of the iron post to increase the area of support. The other method is to flare the bottom of the pipe or post.

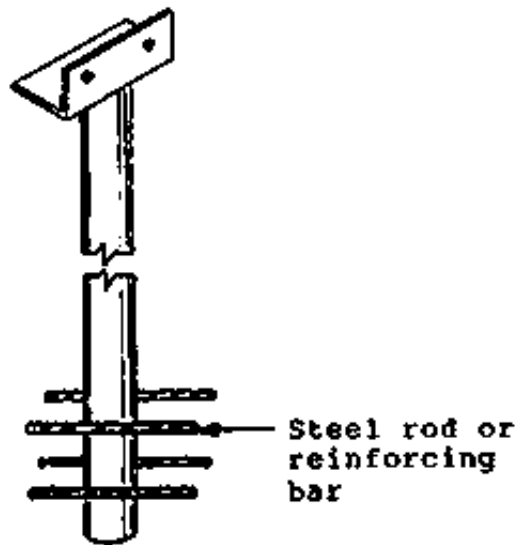

Steel rods welded to the stump

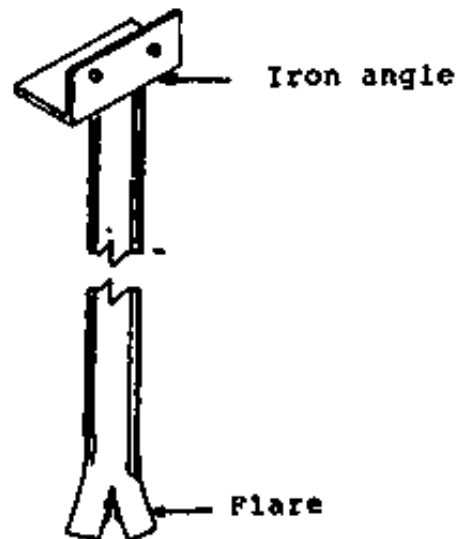

Bottom of stump flared

b) Treated timber post: - On top of the treated timber post there should be a notch. At least the bearer has to sit in the notch two third of the thickness of the

bearer.



Figure

c) Concrete stump: - For concrete stumps you have to make a formwork and place an anchor before the concrete get dry.

It is advisable to lay reinforcing bars. Reinforcing bars are placed on each corner.

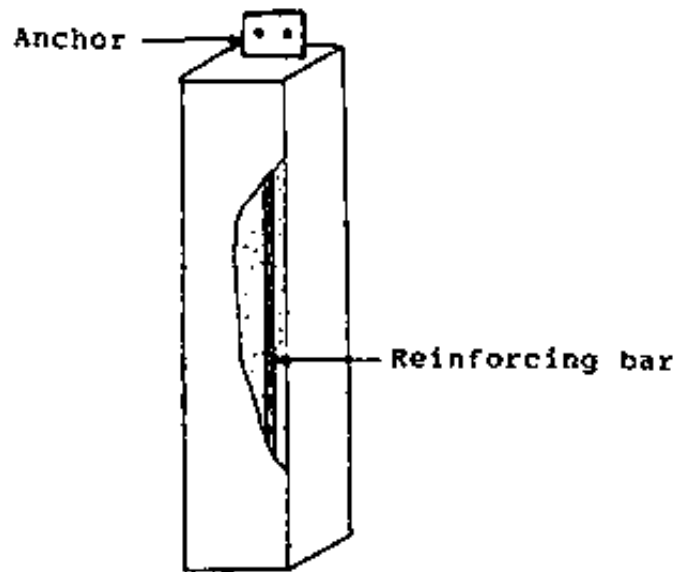

Figure

5.3. Correct embedding of piers or stumps

When the piers are embedded in the concrete footing it is important that at least 150 mm of concrete is left between bottom of pier and bottom of the footing.

- Too close to the bottom and the pier might push through and sink into the ground.**

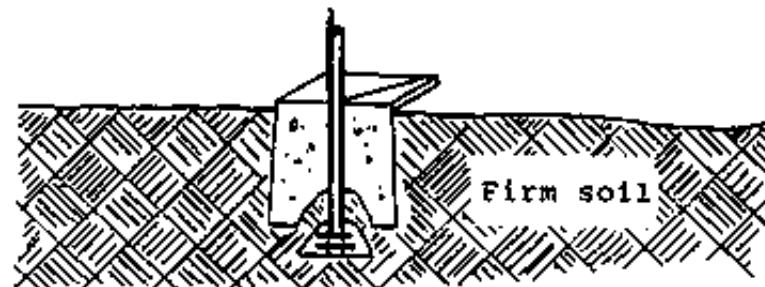

Figure

- The pier is in the correct distance to the bottom.

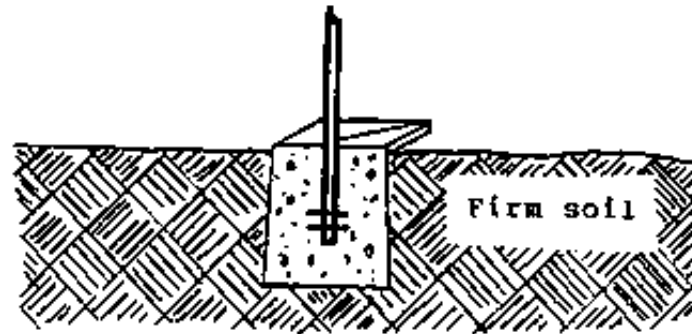

Figure

5.4. Finish

To make a neat finish of the footings and protect the piers the level of the top of the footing must be above ground level. Use boxing to ensure squareness and finish with a steel trowel. The surfaces of the footing must slope away from the pier.

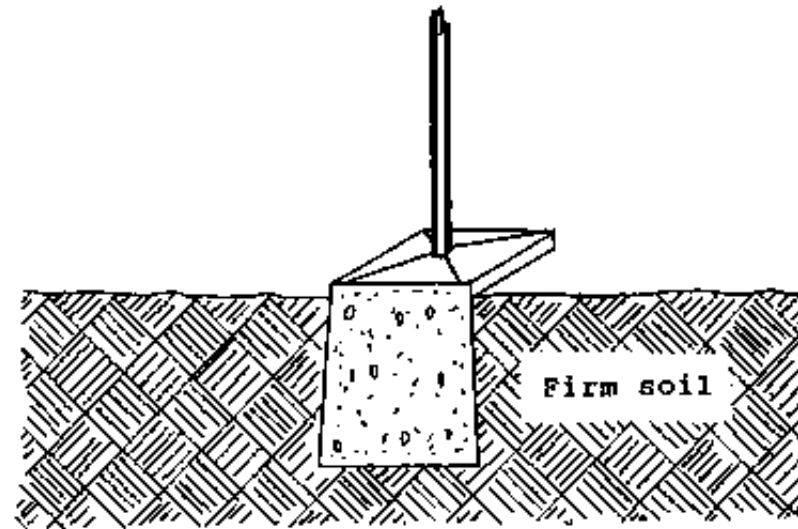

Figure

5.5. Strip footing on concrete block wall

Strip footing is the thicker section of concrete at the base of a column, load-bearing wall, masonry wall or block wall. The strip footing is reinforced by D12 (deformed 12 mm diameter) bars. The cement mortar should be composed of one part by volume of cement to four parts by volume of sand. (1:4) For vertical reinforcement again D12 bars are used and spaced 600 mm apart too.

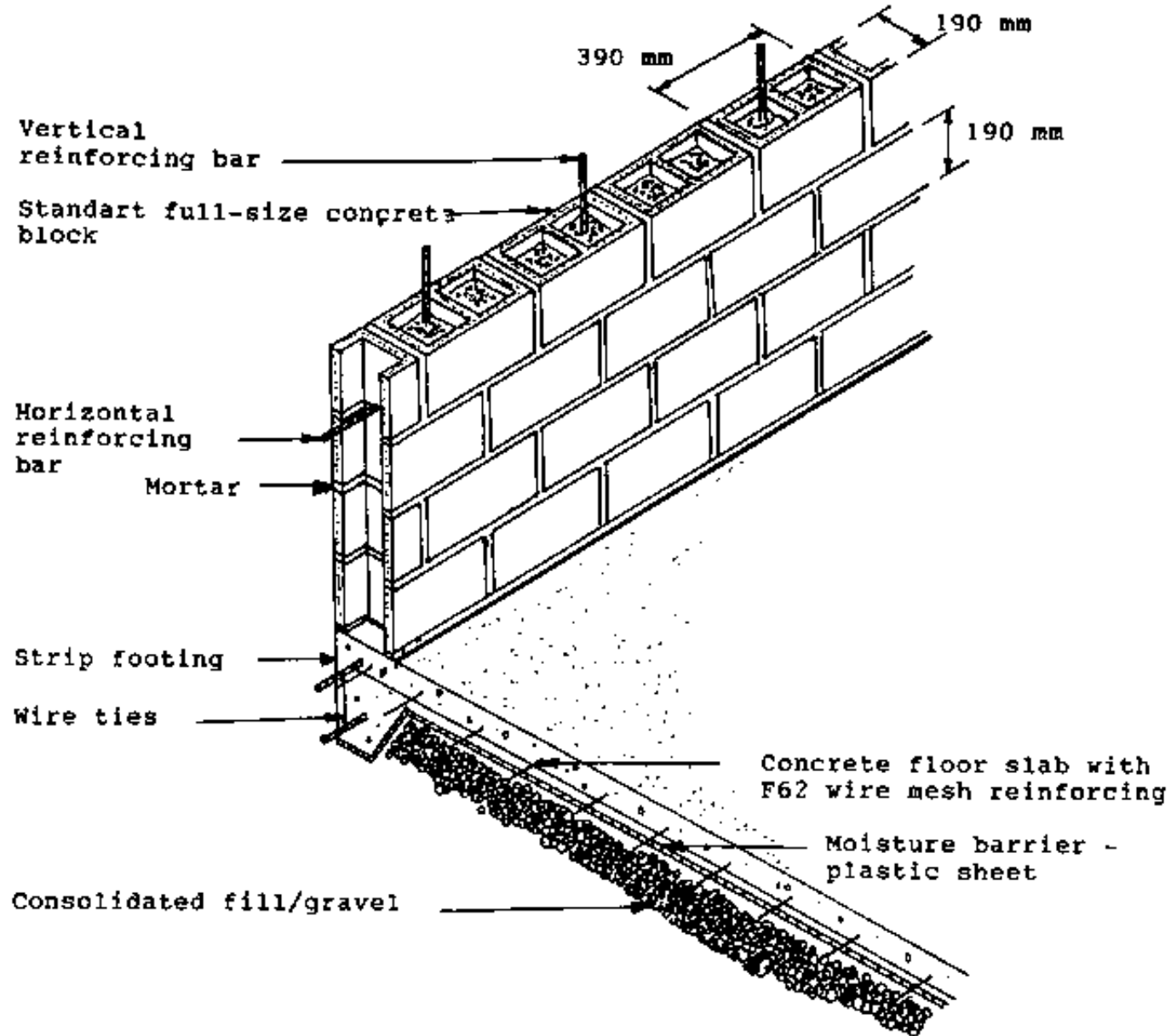

Figure

5.6. Control joints for concrete block wall

Concrete expands and contracts with extremes of temperature or with variations in temperature. It may also shrink and cause random cracks. To prevent random cracks control joints are build in the concrete block wall. These control joints are build if the wall exceed 10 metre in their length. There are different types of control joints, the are named : Michigan type, Gasket type, Control block type and racked type.

a) Michigan type:

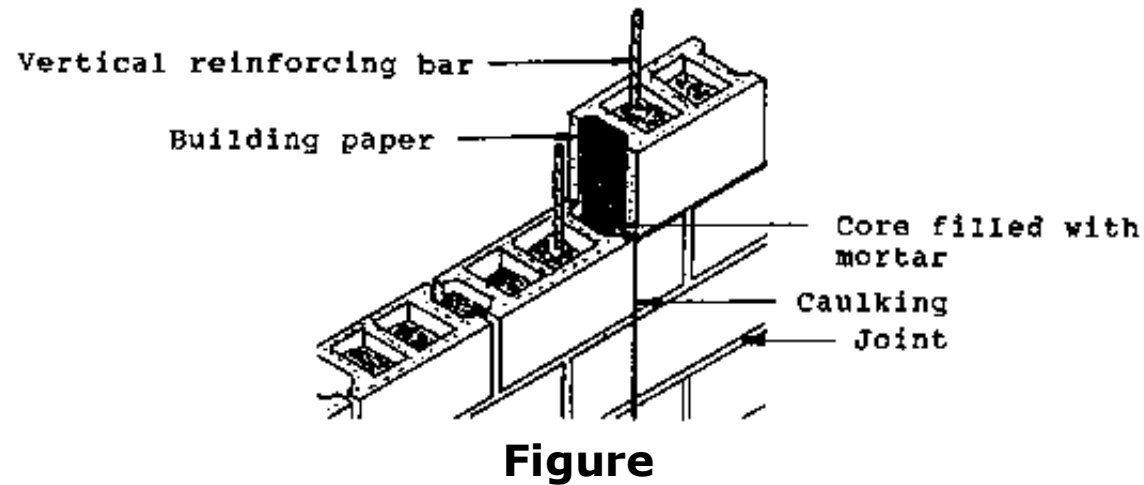

b) Gasket type:

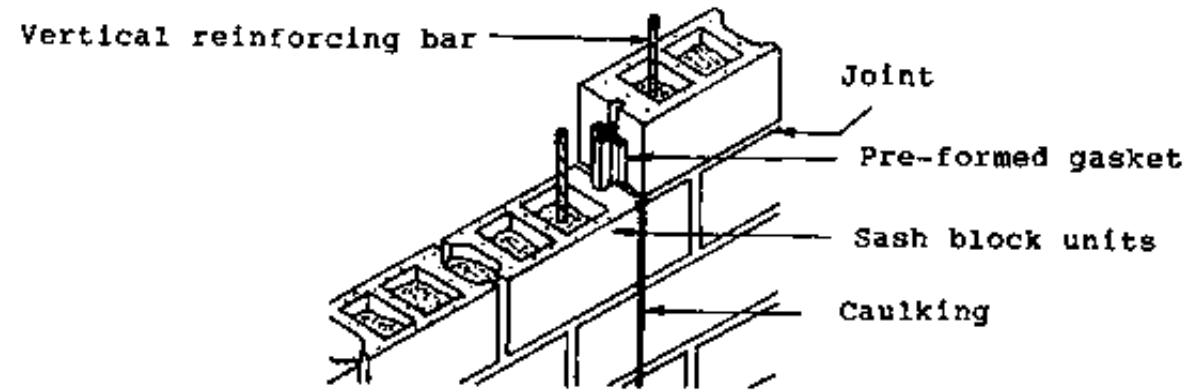
**Figure**

c) Control block type

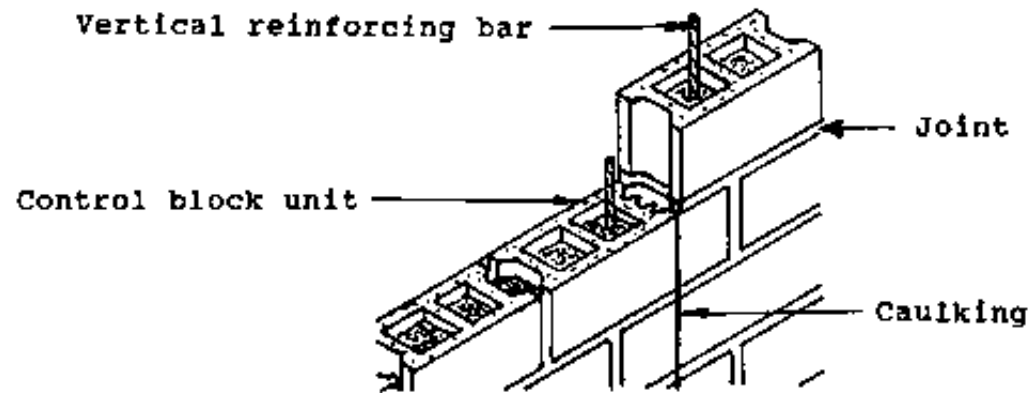
**Figure**

d) Racked type:

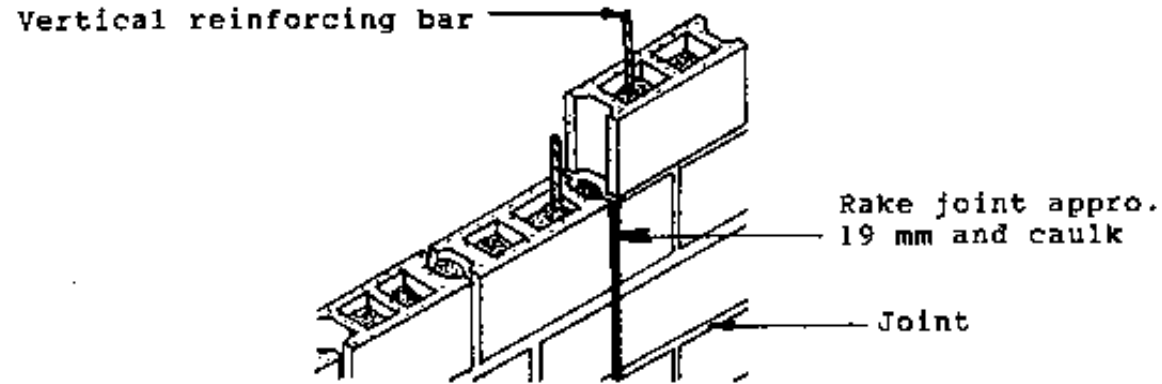

Figure

5.7. Applying mortar to a block

The mortar is applied to the lower row of the blocks. Apply enough mortar at both edges so that the distance of the blocks has 10 mm. Afterwards fill out the cavities of the blocks.

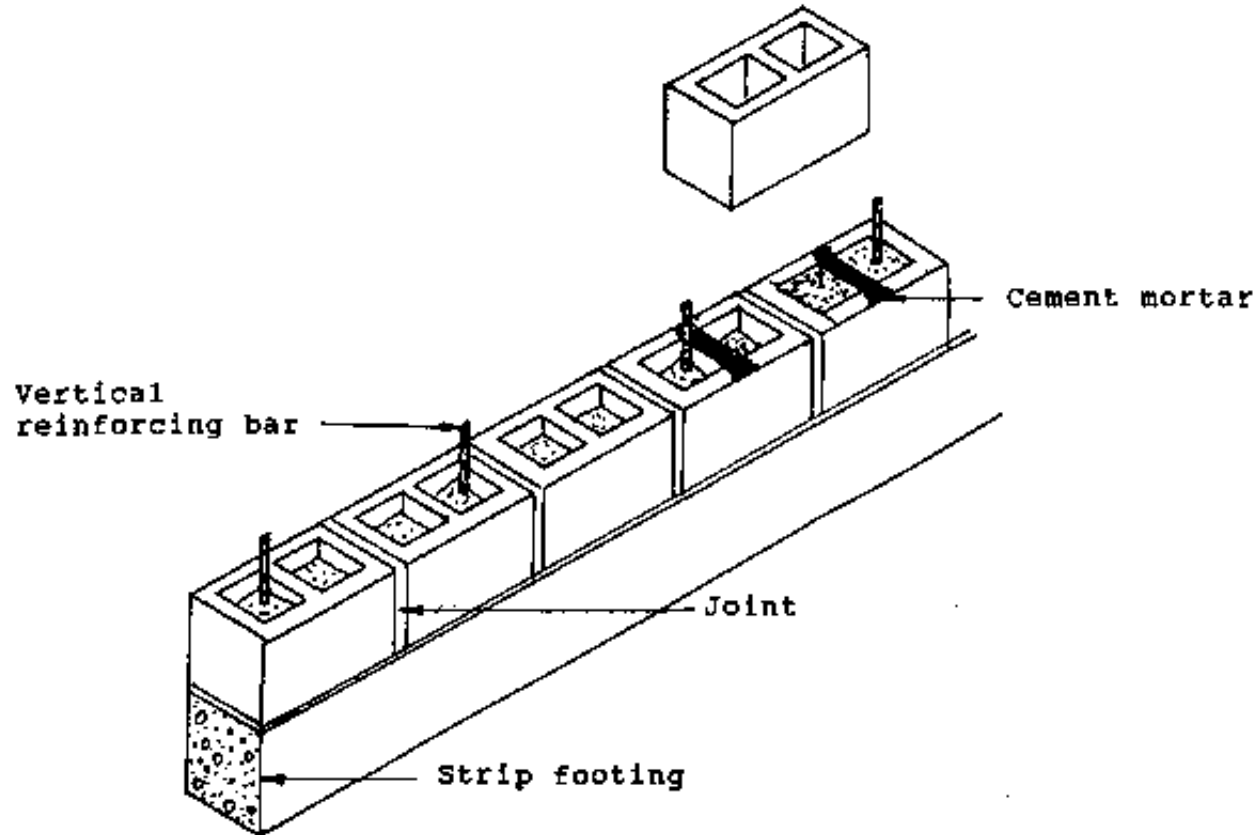

Figure

5.8. Strip footing on masonry (concrete) wall

For reinforcement, D12 bars are used. Horizontal reinforcement is spaced 480 mm apart and vertical reinforcement have a distance of 600 mm.

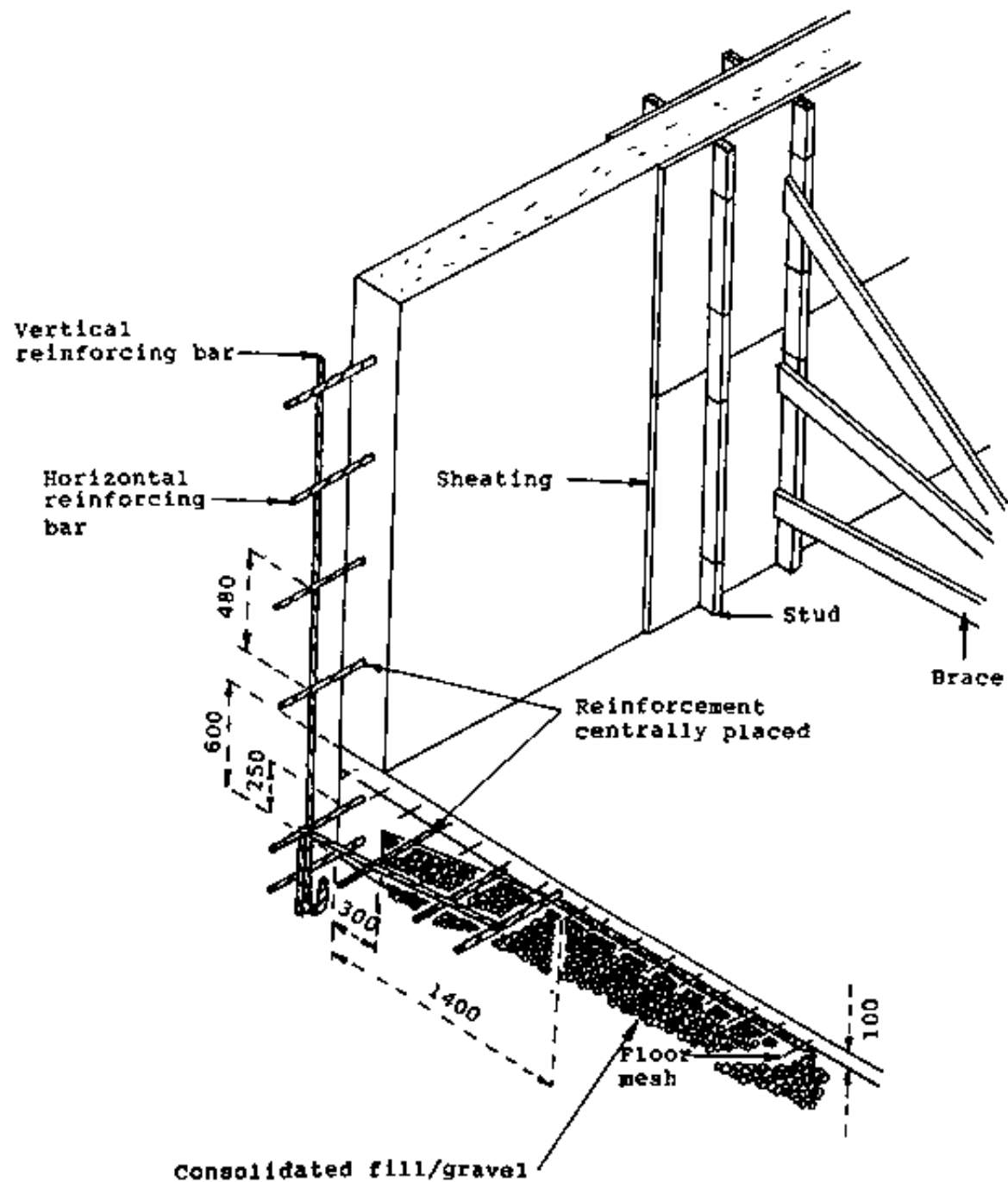

Figure

5.9. Different types of strip footing

Footings has to carry the weight of a building. It depends of the type of the wall, number of storeys and thickness of the walls. A masonry (concrete) wall is much heavier than a column wall. Therefore the footing of a masonry wall is stronger than the footing of a column wall.

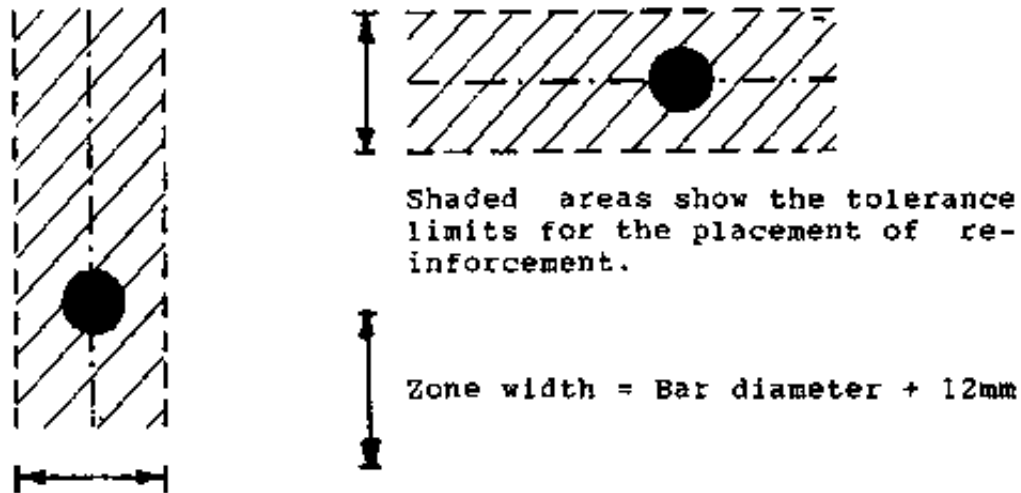

Figure

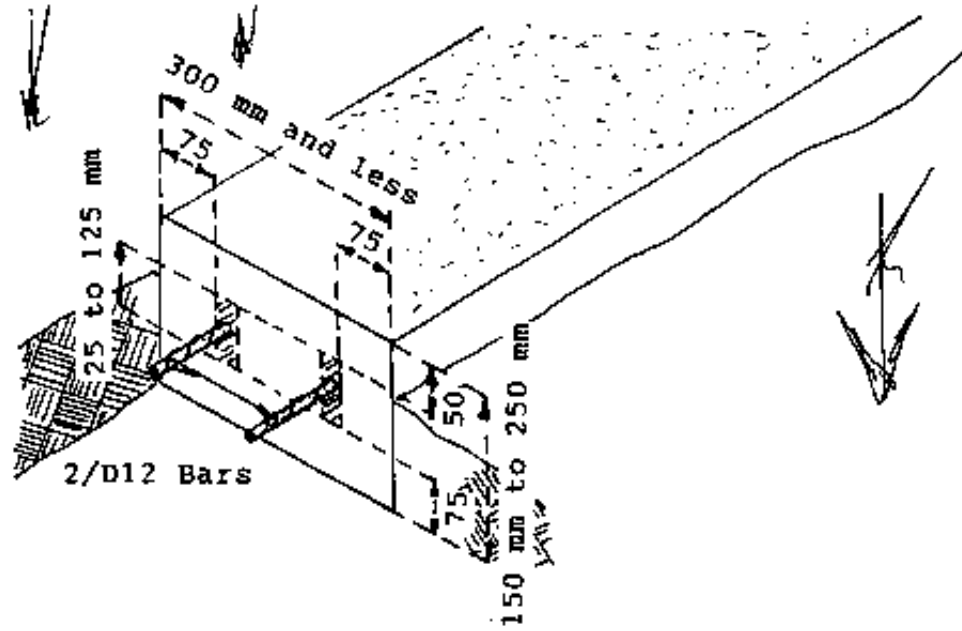

Figure

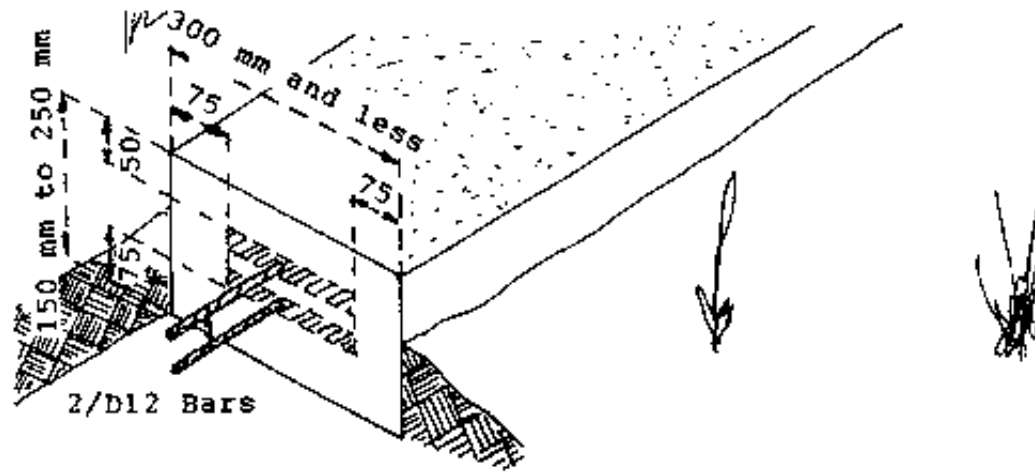

Figure

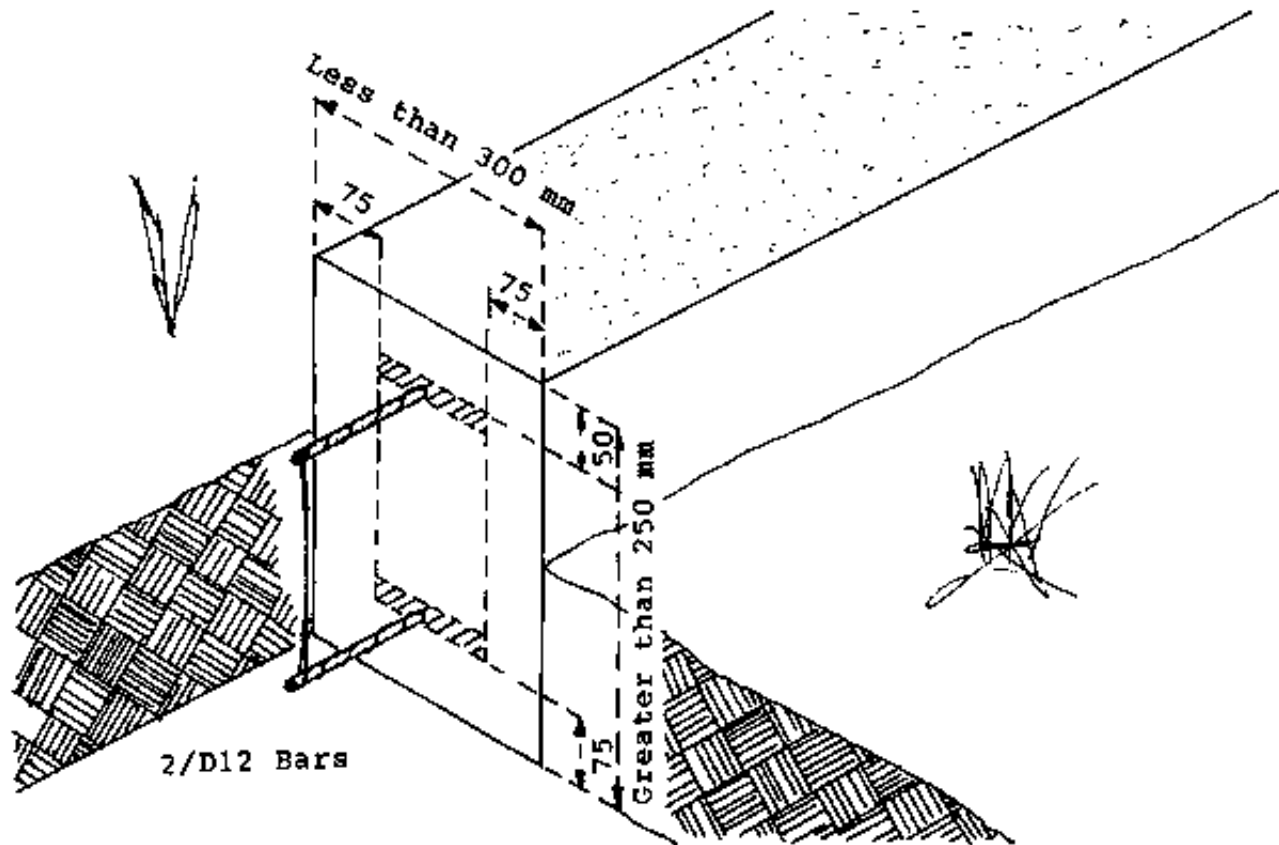

Figure

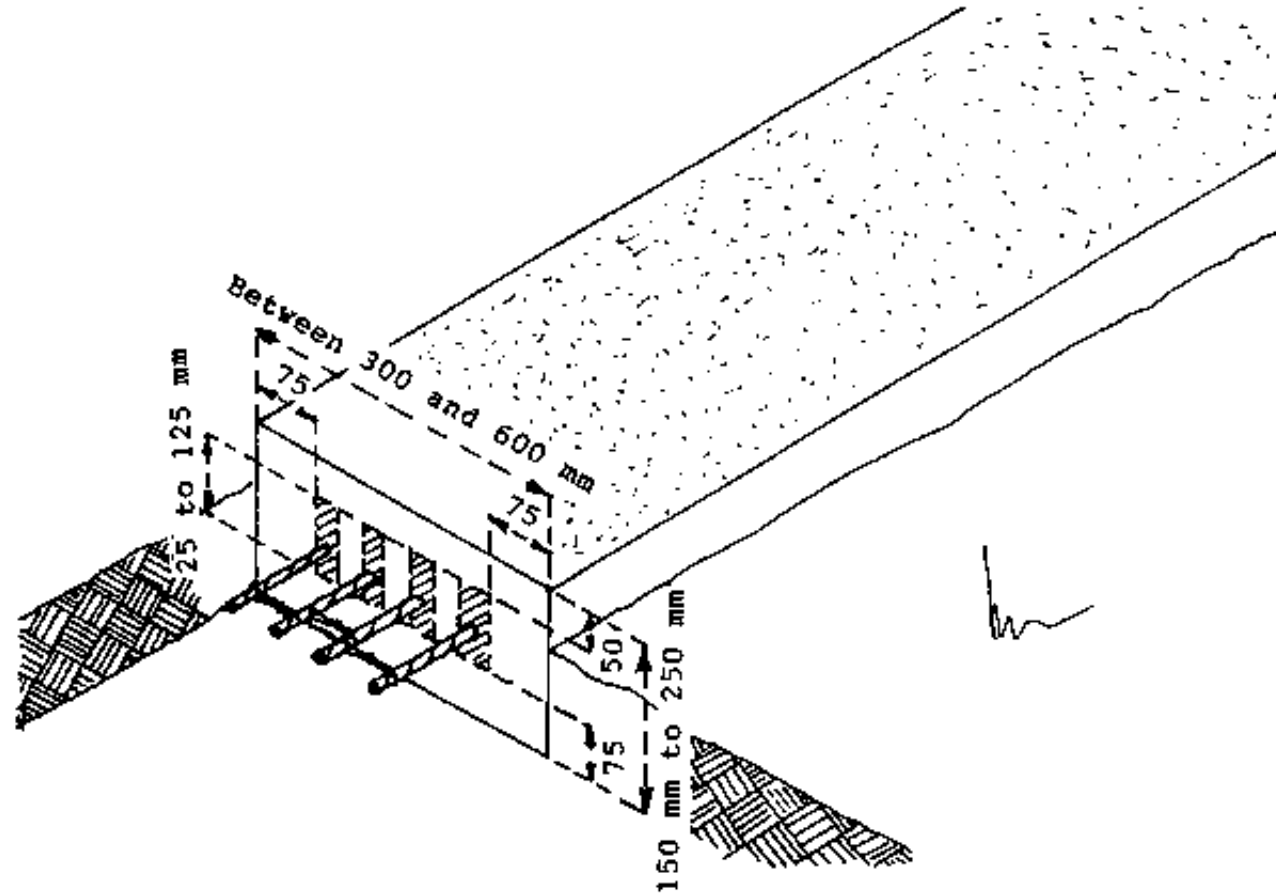

Figure

4/D12 bars or 2/D16 bars for footing less than 400 mm wide.

6/D12 bars or 3/D16 bars for footing between 400 mm and 600 mm wide.

R.D. = Reduce distance to provide the correct cover. Cover means the distance from the bar to the surface.

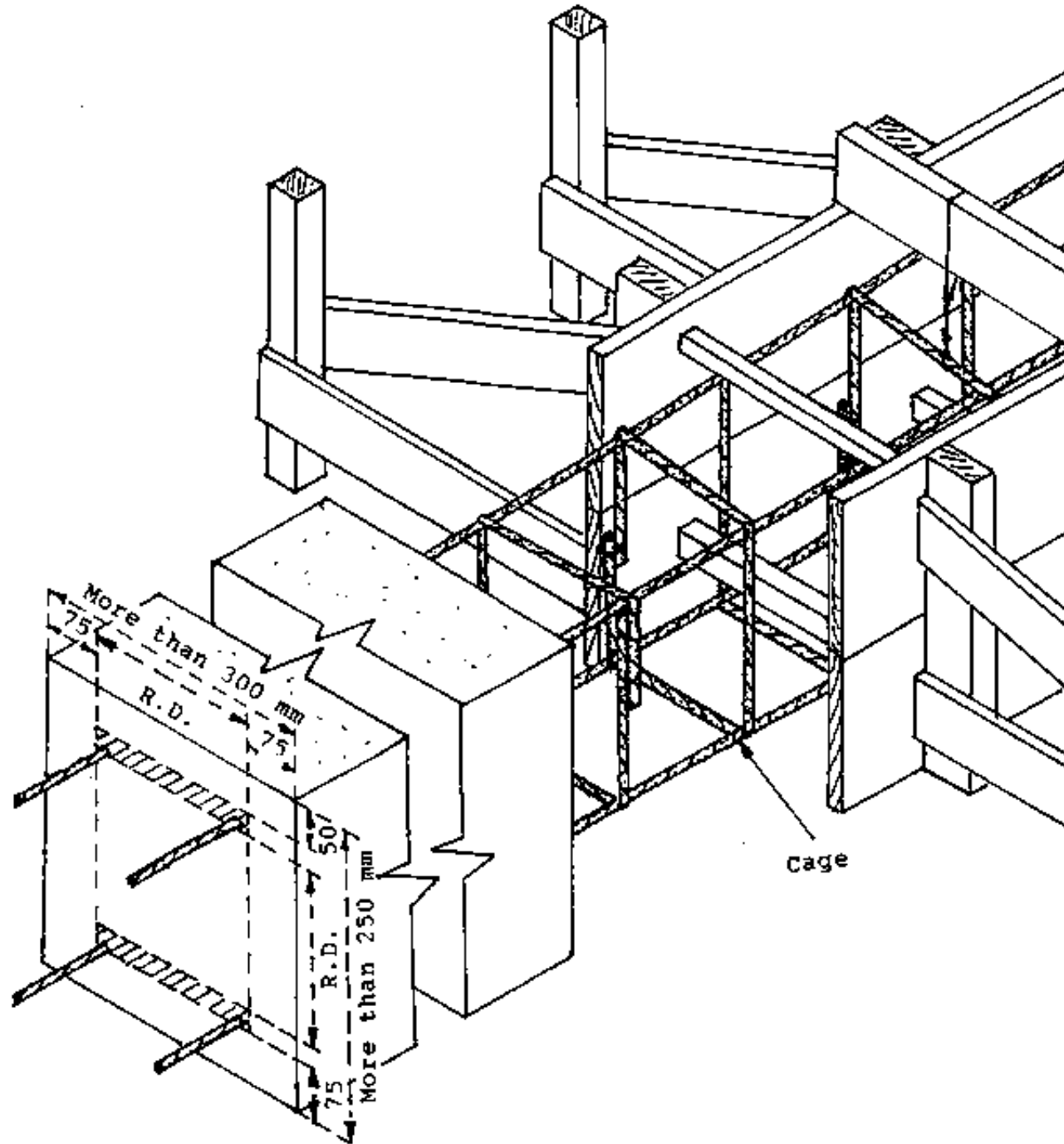

Figure



[Home](#) > [ar.cn.de.en.es.fr.id.it.ph.po.ru.sw](#)

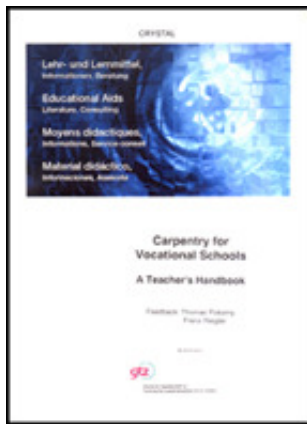

Carpentry for Vocational Schools - A Teacher's handbook (GTZ, 252 p.)

6. TOOLS USED ON BUILDINGS

 **(introduction...)**

 **6.1. Marking out tools**

 **6.2. Sharp edge cutting tools**

 **6.3. Maintenance of chisel and plane iron**

 **6.4. Tooth cutting tools**

 **6.5. Maintenance of crosscut saw and rip saw**

 **6.6. Boring tools**

 **6.7. Driving tools**

 **6.8. Guiding tools**

 **6.9. Bricklaying tools**

 **6.10. Concrete working tools**

Carpentry for Vocational Schools - A Teacher's handbook (GTZ, 252 p.)

6. TOOLS USED ON BUILDINGS

TOPIC: 6. TOOLS USED ON BUILDINGS

INTRODUCTION: This section teaches students the different tools used on buildings, how they are used and maintained properly.

We select those tools first which are needed from the very beginning of the school, like hammer, saw, trisquare and chisel. An idea would be to teach the basic tools and their maintenance in the beginning of the first year and later in the year the other tools and their maintenance.

OBJECTIVES:

6.1. Students should be able to name all marking out tools, their parts, their application and how to handle and use them correctly.

6.2. Students must be able to identify all the parts of a chisel and plane and be able to use them in the correct way.

6.3. Students have to know the procedure for sharpening a plane in theory and practise, on the grinder as well as on the oilstone.

6.4. Students should be able to identify the different hand saws, their characteristics and their uses.

6.5. Students have to be able to sharpen a saw by following the four chief operations.

6.6. Students should be able to state all parts of a hand drill and a bit brace

and must be able to use them correctly.

Students also must be able to identify the different bits, their characteristics and their uses.

6.7. Students should be able to identify and use driving tools correctly.

6.8. Students should know all guiding tools and be able to use them correctly.

6.9. Students should be able to name all the bricklaying tools and their uses.

6.10. Students should be able to identify the different concrete-working tools and be able to use them correctly.

METHODS: Teaching the correct use and maintenance of tools is more effective if it is combined with practical exercises and demonstration in the workshop.

However, sometimes there are not enough tools for the whole class especially grinder and stones for sharpening practise.

An idea would be to split up the class into smaller groups when practising in the workshop.

For the lesson in the classroom we prepare photocopies of the different tools and samples of each tool for explanation of their purpose, the correct use and its maintenance.

NOTE: At the end of this topic a worksheet is prepared for the students to fill in in their own time for assessment later.

Tools are classified according to the work they do, into various groups of which the following are the main ones:

Marking out tools, sharp edge cutting tools, Tooth cutting tools, Boring tools, Driving tools, Sharpening tools, Guiding and Testing tools and Brick laying tools.

6.1. Marking out tools

a) Tape measure: - Is used for measuring straight lines and setting out work. Usually graduated in mm and cm length and inches.

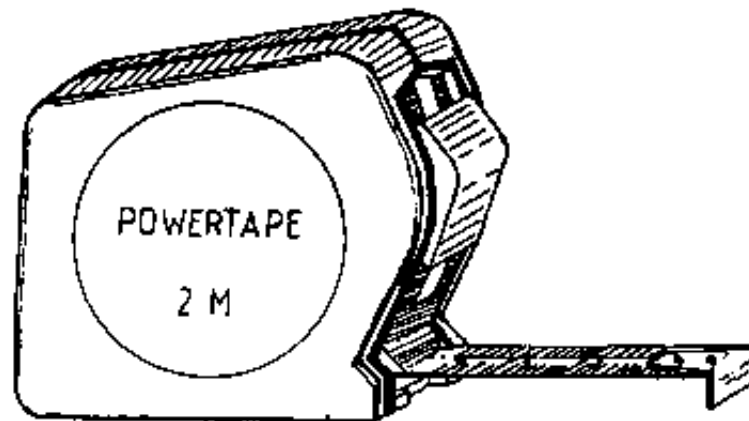

Figure

b) Pencil: - Is used for marking and setting out lines on the prepared timber. It should be used an HB or H pencil as it keeps a sharp edge for longer periods. A soft pencil gets blunt quickly.

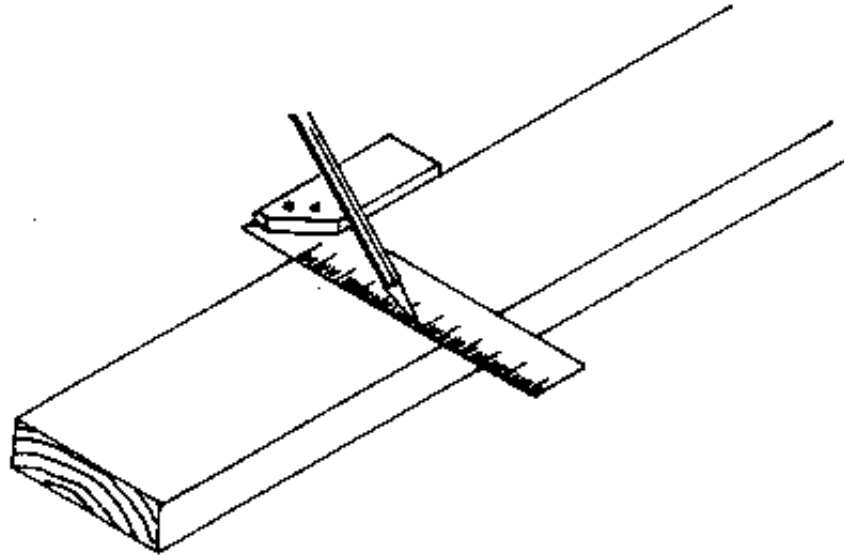

Figure

c) Try square:

- These are made either all metal or with a wooden stock and metal blade. They are supplied with blades ranging from 100 mm to 450 mm in length and are used for either squaring lines across the face or edge of timber, for testing the squareness of the edge from the face, and for testing the flatness of the timber surface.

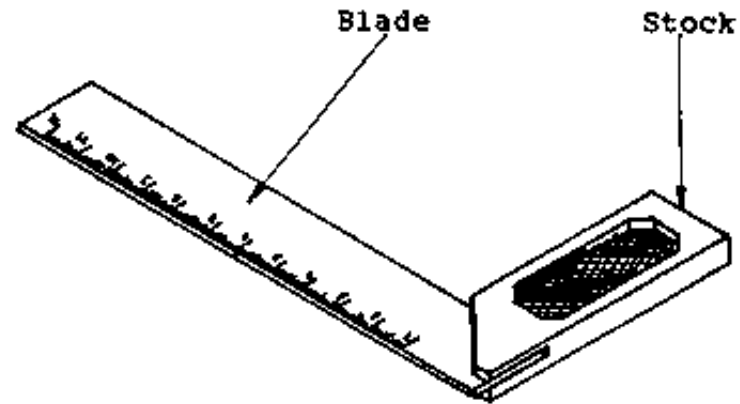

Figure

- Trueness of the try square: Care should be taken exercised when testing it. The test is - place the stock against the straight edge of a piece of wood and mark a fine line against the edge of the blade; then reverse the stock, and if the edge of the blade coincides with the line, the square is true; if not, half the difference will be the amount of the error. Both edges of the blade should be tested and if necessary corrected by filing.

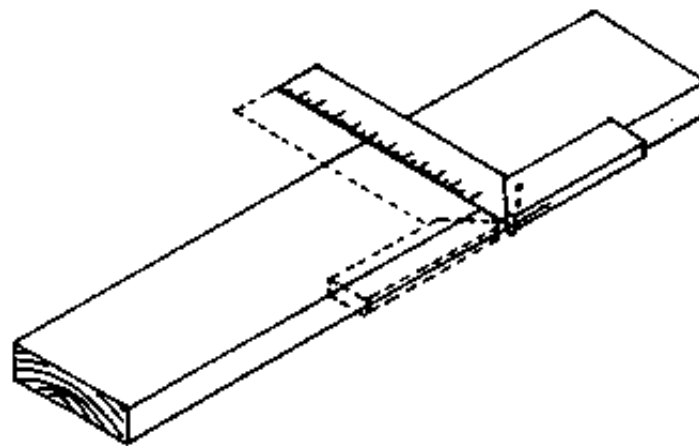

Figure

d) Combination Try Square: - It is a tool that combines four marking-out tools in one. It has a slotted blade passing through a stock which gives a right angle on one side and a mitre angle on the other. Attached to the stock is a small spirit level for testing level and uprightness. Because of the adjustable stock it is possible to use it as a marking gauge.

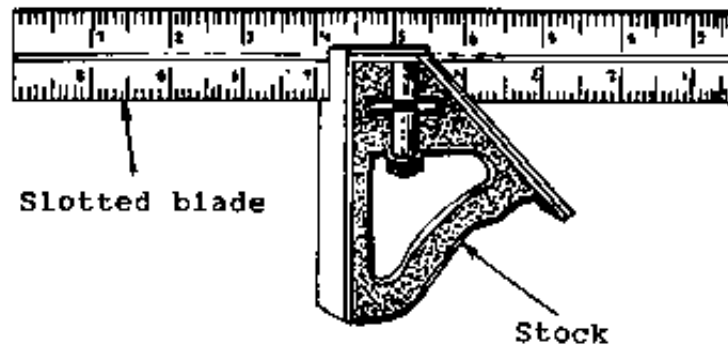

Figure

e) Sliding Bevel: - The sliding bevel can be set to any angle other than a right angle. These can be obtained with either a wood or metal stock, with a sliding blade from 150 mm to 300 mm length which is fixed, in the case of a wooden stock by a screw or lever nut, and in the case of a metal stock by a blade clamping screw which runs down the centre of the stock.

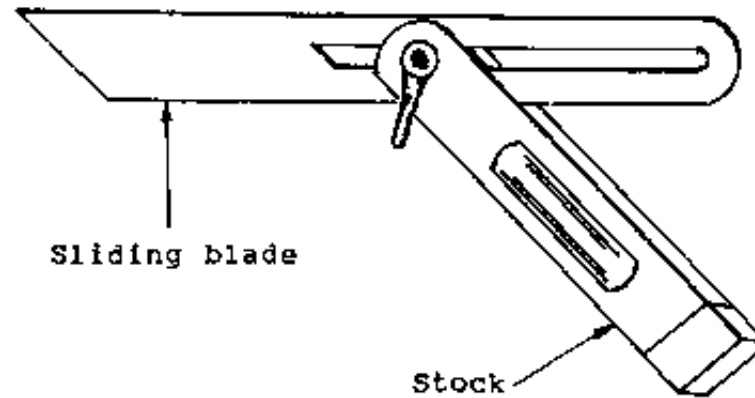
**Figure**

6.2. Sharp edge cutting tools

a) Bevelled edge firmer chisel: - They have bevelled edges and range in size from 100 mm to 200 mm length and from 2 mm width increasing by 2 mm up to 12 mm, and then by 3 mm up to 38 mm width. It is a general utility tool, being used for short paring work and for light mortising. For the latter, a mallet is used in conjunction with the chisel to force it into the fibres. The blade is secured to the handle by means of an iron tang driven into the handle. By wooden handle there is a brass ferrule around the blade end of the handle.

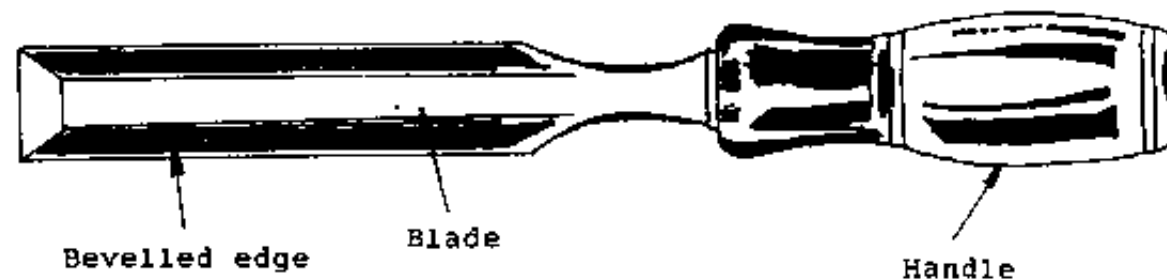
**Figure**

b) Metal smoothing plane: - The metal smoothing plane is a cutting tool, which is used when producing straight, flat and square surfaces. The plane is also used to produce a finished unit of the required shape and smooth the wood surface. Smoothing planes range in size from 150 mm - 250 mm in length and 50 mm - 60 mm in width. The smoothing plane consists of the metal base, the mouth opening, the toe, the heel, the plastic knob, the plastic handle, the depth adjusting nut, the lever, the lever-cam, the cap iron, the plane iron cutter.

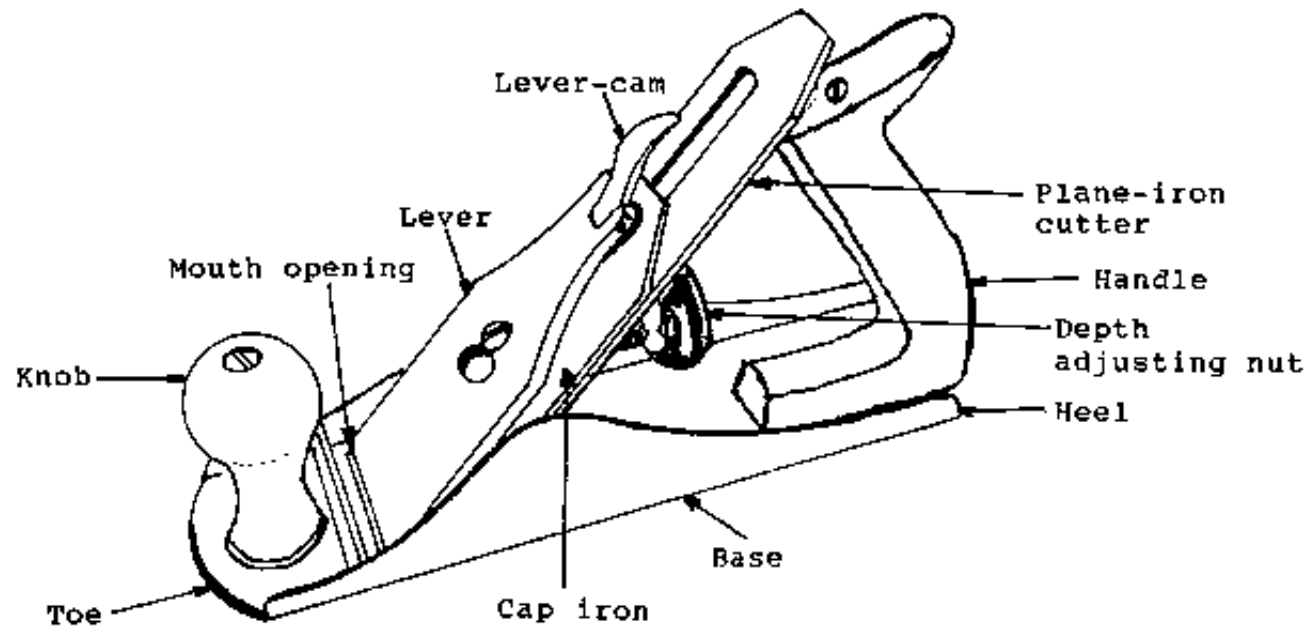

Figure

6.3. Maintenance of chisel and plane iron

a) Grinding: - The cutting edge of the plane iron or chisel is the part that shaves or cuts the wood material. It is important for the effectiveness of the planing or cutting operation that the plane iron or chisel is properly sharpened. The first

stage of sharpening is grinding. Adjust the tool rest of the grinding machine that the cutting edge has an angle of approximately 25 degrees to 30 degrees or twice the thickness of the plane iron or chisel. Press the plane iron or the chisel against the grindstone and held it firmly on the tool rest, while moving the iron from side to side in order to sharpen all parts of the cutting edge. Dip plane iron into water often to prevent burning (blueing) or overheating, because this softens the metal.

For safety, wear safety goggles or use eye shield.

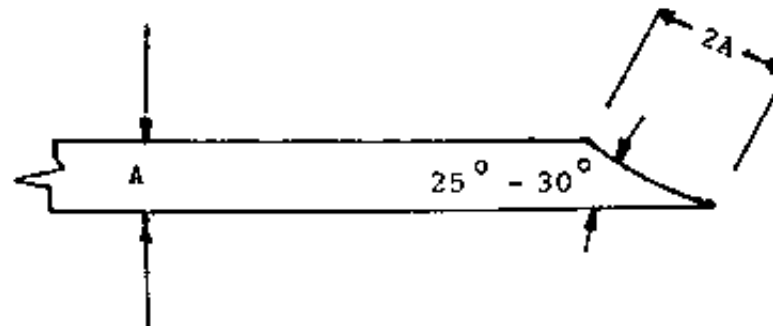
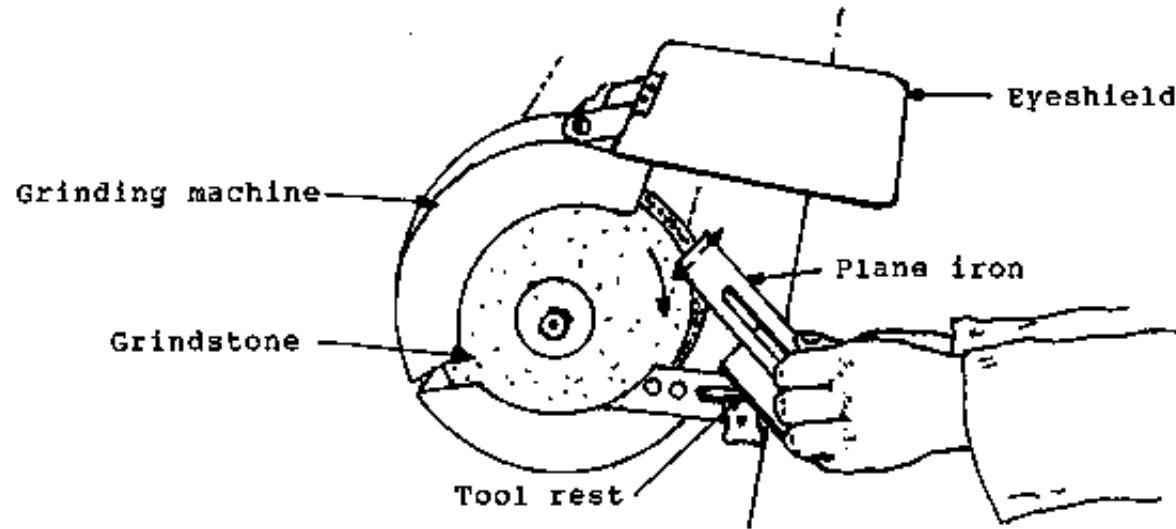

Figure

b) Honing: - It is possible to hone a chisel or plane iron 3-5 times before you have to grind it again - provided you are careful when honing. Produce a honing bevel by raising the back edge of the tool slightly. Move the plane iron or chisel back and forth across the surface of the oilstone. To remove the wire edge which forms, lay the iron flat on the oilstone with the bevel up and move in back and forth a few

times. Under no circumstances should you produce a bevel on the flat side of the tool.

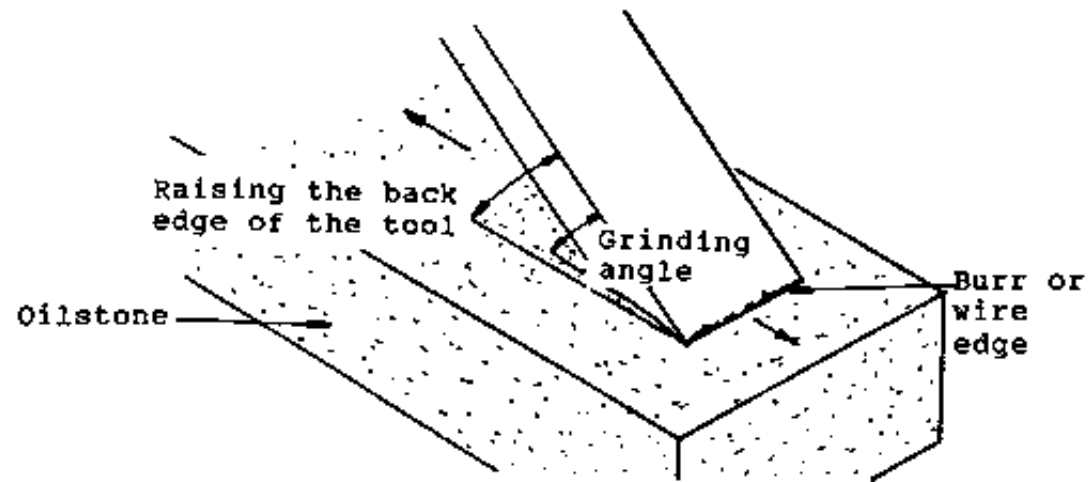

Figure

Remove wire edge: lay the iron flat on the oilstone, don't raise the iron to produce a bevel.

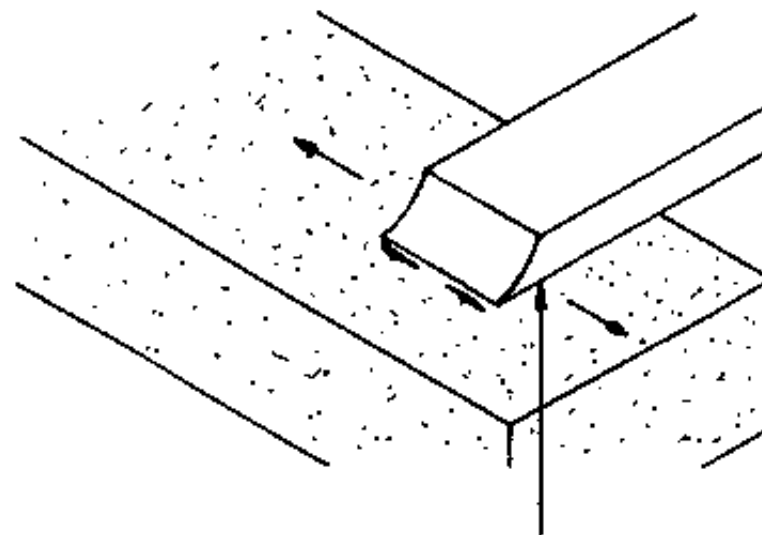

Figure

c) Maintenance of plane cap iron: - The cap iron on the plane is there to strengthen the cutting edge and bread the shaving away from the surface thus ensuring a smooth finish. However, if the cap iron does not fit tightly to the cutting iron, shavings may get stuck between the cap iron and the cutting iron clogging up the mouth of the plane and tearing the surface of the work. Carefully file the cap iron to fit against the cutting iron.

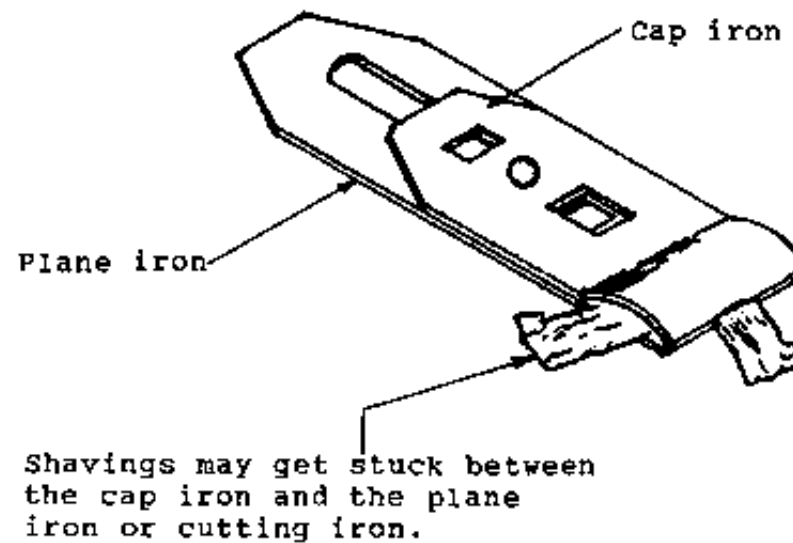

Figure

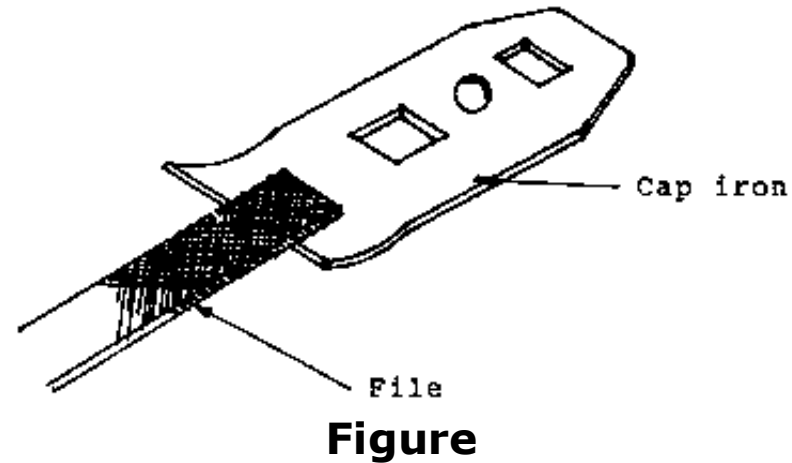

6.4. Tooth cutting tools

Tooth cutting tools or saws are main tools for a carpenter. the most commonly used saws by a Carpenter are the Crosscut saw, the Rip saw, the Back saw and the Hack saw.

a) Crosscut saw:

- This saw is designed to cut across the grain of the wood. Its teeth are sharpened like a knife so that they will cut the wood fibres on both sides of the saw cut or kerf. Basically all crosscut hand saws are similar. The main differences are: the length of the blade, the shape of the teeth, the number of teeth per 50 mm.

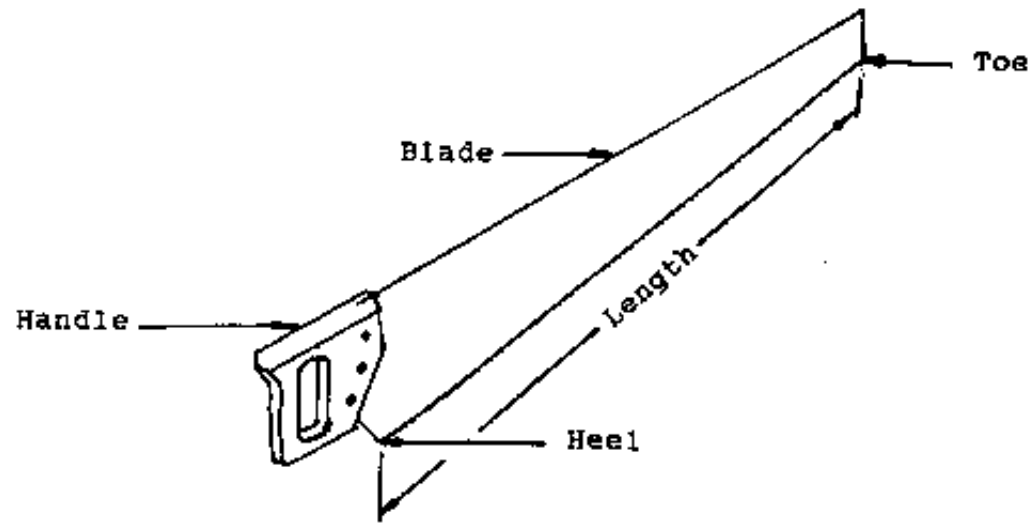

Figure

- All saws are referred to by their length and the number of teeth points per 50 mm. On some saw the number of saw teeth points is stamped near the heel of the saw blade. A good size crosscut saw for average use by most carpenters on wood framed buildings is a 711 mm 10 - 16 point saw tooth per 50 mm.

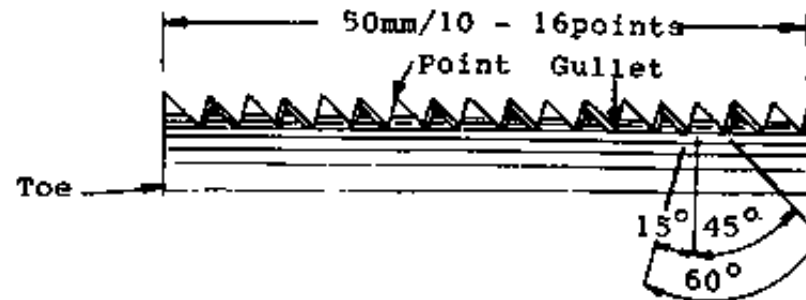

Figure

- Cutting action of crosscut saw: the shape of the teeth have a cutting

action similar to a series of knives.

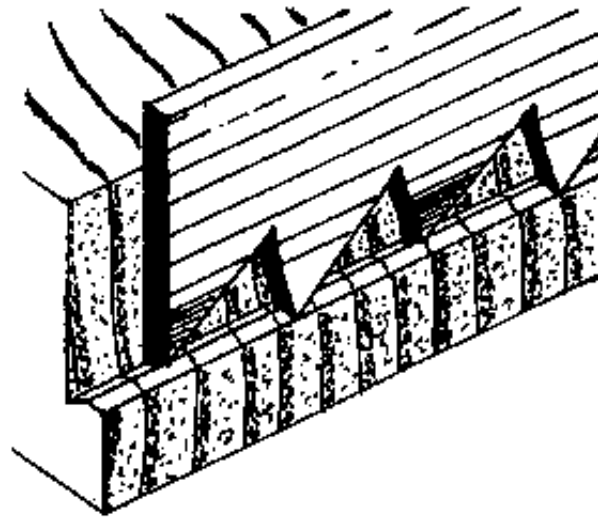

Figure

b) Rip saw:

- This saw is used to cut wood with or along the grain. Rip saws are referred to by their length and number of saw teeth per 50 mm. On some saws the number of teeth points is stamped near the heel of the saw blade. The most common and universal is the 660 mm in length with between 8-12 points per 50 mm. Basically all rip saws are similar, the main differences

are: the length of the blade the shape of the teeth, the number of teeth per 50 mm.

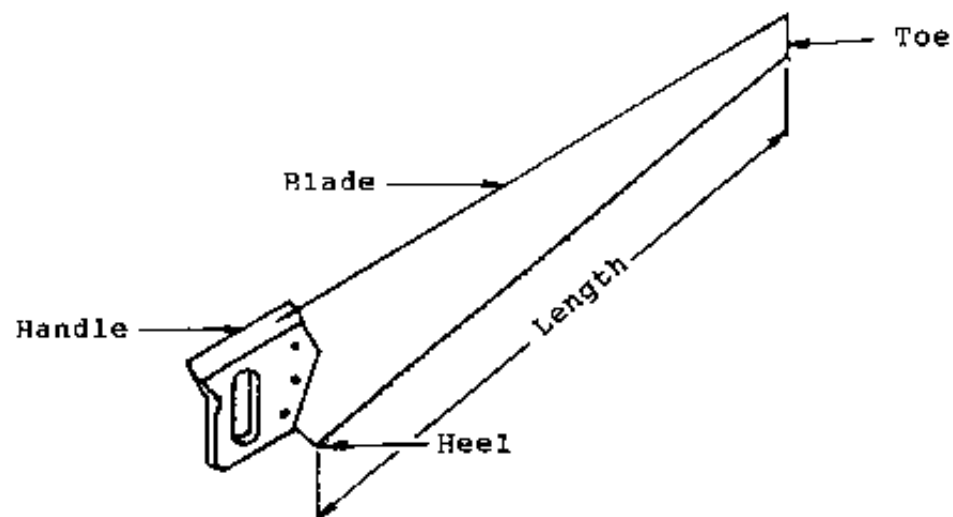

Figure

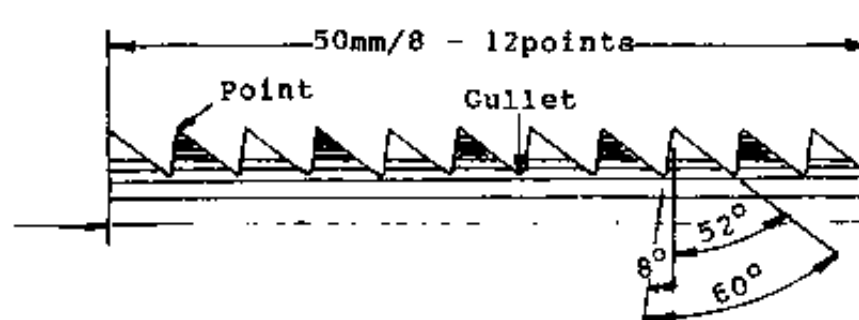

Figure

- Cutting action of rip saw: the shape of the teeth have a cutting action similar to a series of chisels.

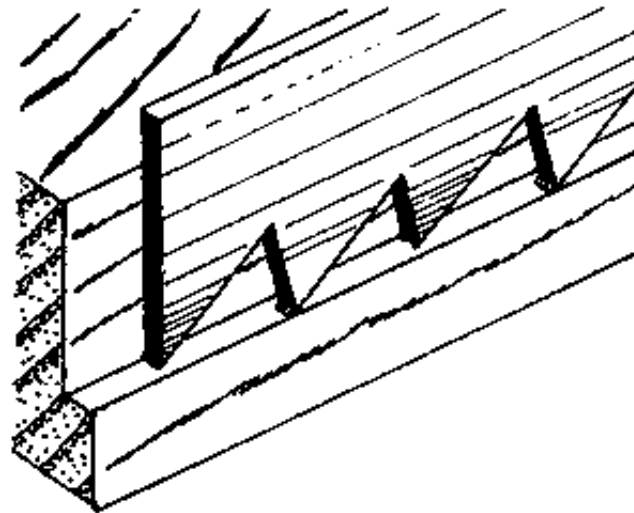

Figure

c) Back saw: - The back saw has a metal strip along the back to stiffen the blade. The shorter back saws are occasionally used for close cutting and for precision work. The Back saws range in size from 255 mm - 710 mm and have between 22 and 28 points per 50 mm which makes a very fine and finished cut.

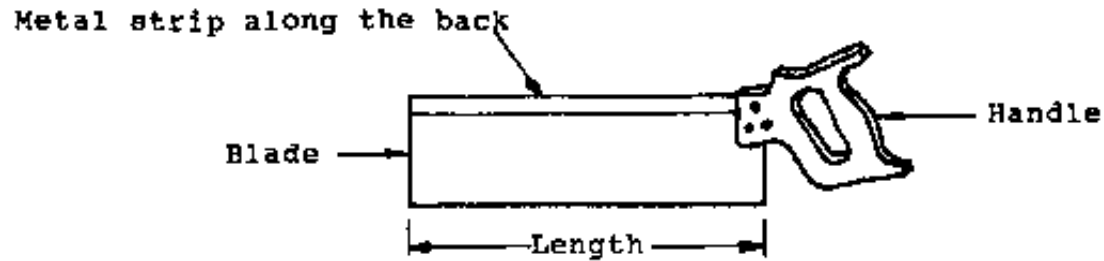

Figure

d) Hacksaw frame/blades: - The hacksaw frame is used with a variety of interchangeable metal cutting blades which are used for cutting soft metals such as copper and aluminium and hard metals such as nails, angle iron and reinforcement steel.

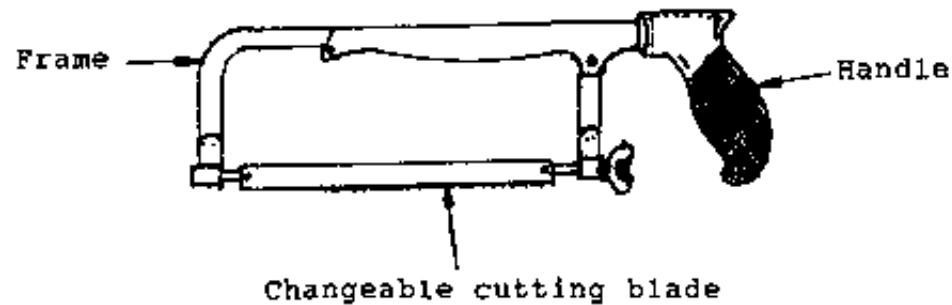

Figure

6.5. Maintenance of crosscut saw and rip saw

- There are four chief operations in sharpening a saw: Topping, Shaping, Setting and Filing.

- Topping means to bring the teeth to an uniform height. Place the saw in a vice and run a flat file, held square to the blade, lengthwise until every

tooth has been touched. The centre should be a little higher than the ends, if in the length of the saw it shows hollow instead of round, it will "kick" when in use.

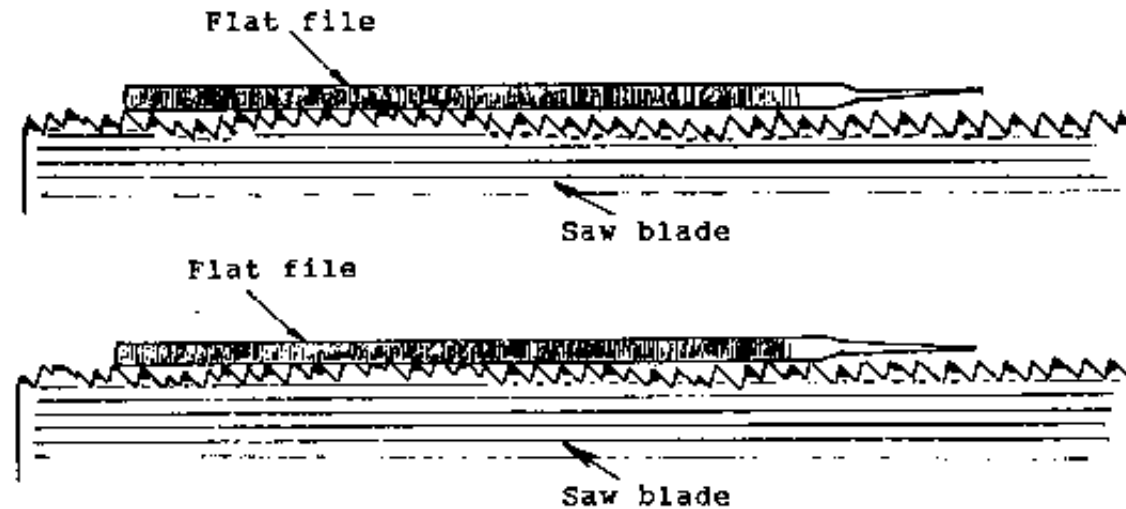

Figure

- Shaping the teeth: after a saw is topped, the gullets will be of unequal depth, the teeth will be of unequal size. File the gullets to equal depth, shaping the front and the back of the tooth. Place the file straight across the saw, keeping the file at right angle to the saw blade.

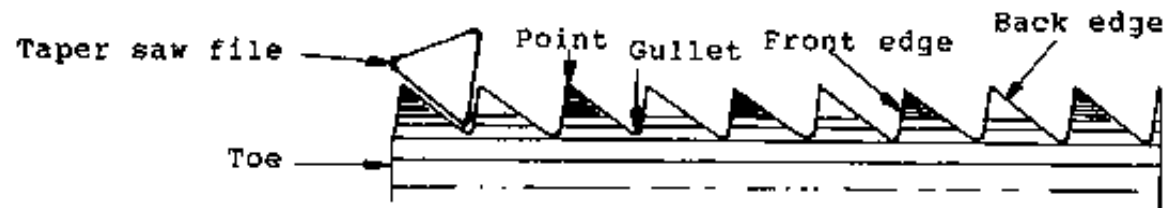

Figure

- Setting: setting of a saw consists in bending over the upper part of each tooth, one to the left and one to the right. The teeth will cut a kerf slightly wider than the thickness of the blade in order to give blade clearance.

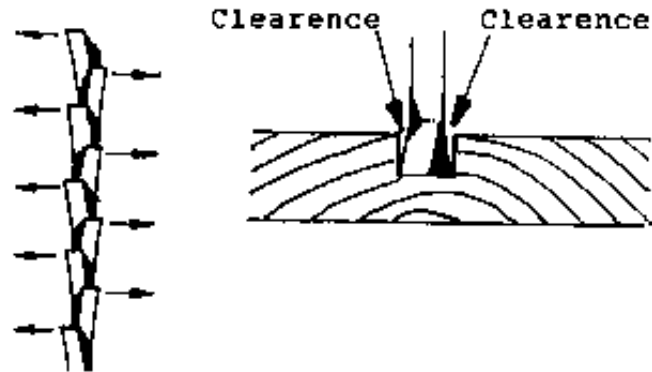

Figure

Setting of the saw can be done quite easily with a pistol type saw set.

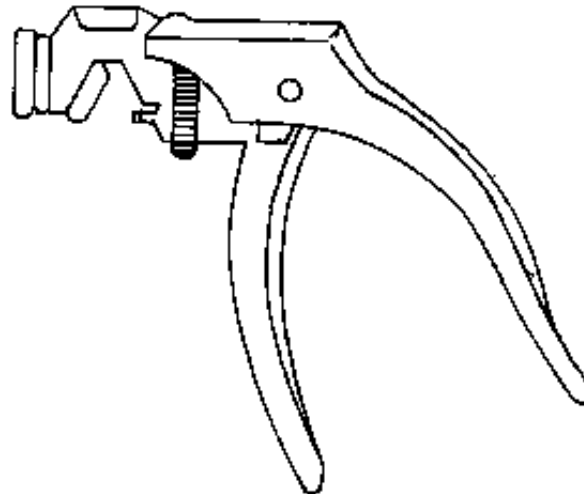

Figure

- The saw set is used by fitting it over the teeth of the saw and pushing the two handles together. The small shaped steel piece will press the saw tooth onto the shaped wheel or anvil.

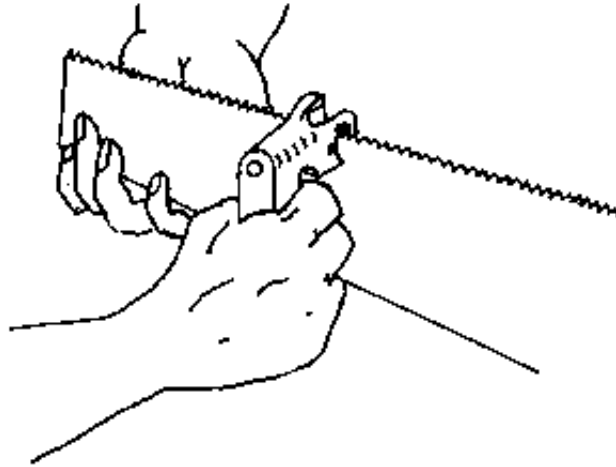

Figure

- Procedure for filing a crosscut saw: place the saw in the vice with the handle to the right and the gullets just above the jaws. Commencing from the handle end of the saw, select the first tooth that is pointed towards you. Place the file in the gullet to the left of this tooth and swing the handle of the file about 30 degrees. Take three or four light cuts instead to a heavy one. File in alternate gullets, then reverse the saw and complete the remaining teeth. The bevels on the front and back of each tooth are formed by swinging the handle of the file to the left.

After topping the teeth will have small flat tops. When filing the first side, remove only half the flats, the remainder should be removed when working from the opposite side.

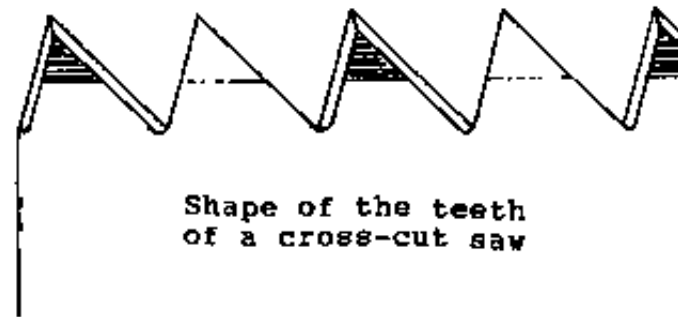
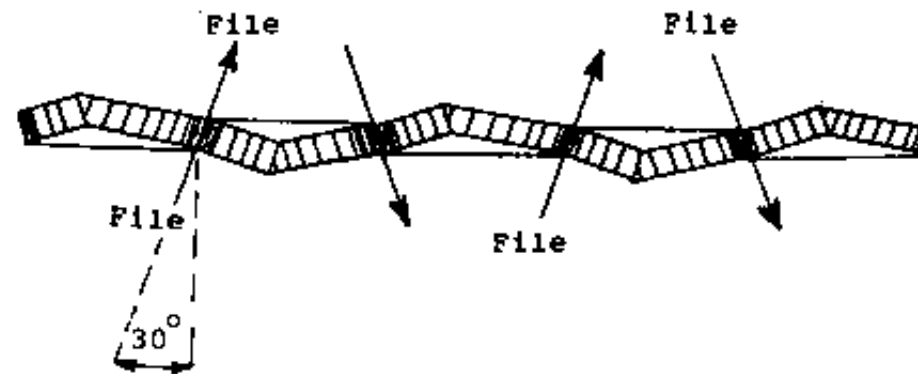
**Figure****Figure**

- Procedure for filing a rip saw: place the saw in the vice with the handle to the right and the gullets just above the jaws. Commencing from the handle end of the saw, select the first tooth that is pointed towards you. Place the file in the gullet to the left and held the file square across the blade. Take three or four light cuts instead to a heavy one, cutting only on the forward stroke. File in alternate gullets, then reverse the saw and complete the remaining teeth.

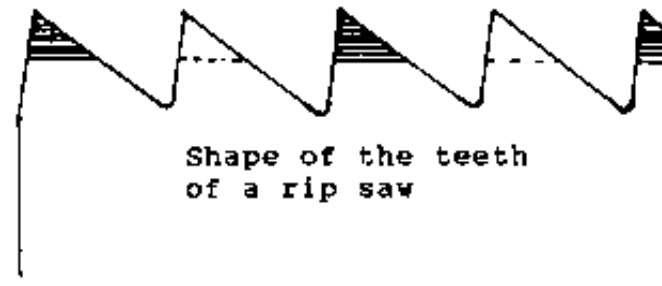

Figure

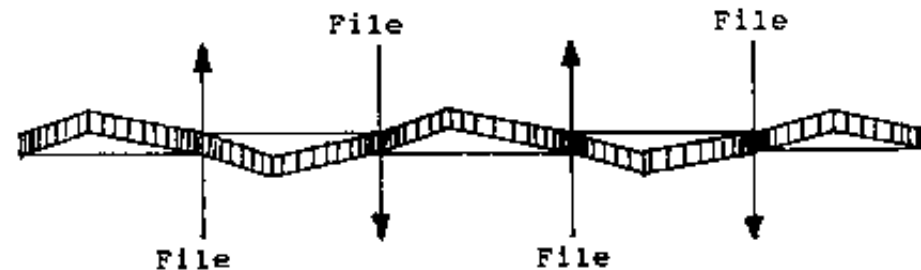

Figure

6.6. Boring tools

Workmen - especially those employed in the construction related occupations such as carpenters, shutterers, plumbers, electricians, masons, have to cut or bore holes in wood, metal or concrete using hand operated drills or/and portable electric drills. With the exception of one, the drill has to be fitted with a drill bit which does the boring. The power is provided by the drill.

a) Hand drill: - The hand drill is operated by cranking. This motion turns the boring tool bit) which will penetrate the wood, metal, concrete, etc...

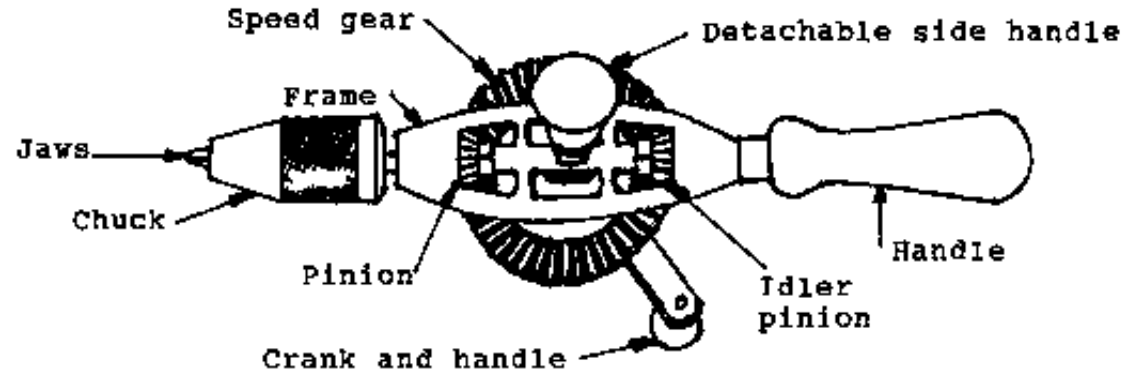

Figure

b) Bit brace: - This tool is designed for use with accessories such as bits, screw drivers, chisels, cinches cutter, countersinks, etc.. It is operated by rotating the middle handle while grasping and pushing the knob handle.

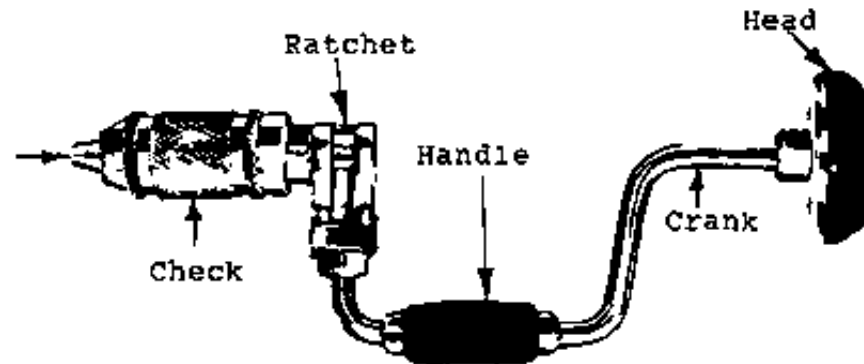

Figure

c) Twist drill: - With centre tip and side cutters 1-10 mm sizes have shanks as per drill diameter. 11 - 15 mm sizes have 13 mm shanks. These drills are used to make holes in wood, metal, fibre, plastic and other materials. Twist drills are used both in hand drills and in power drills. Twist drills are made of different kind of steel:

- a carbon steel twist drill, which is used for boring wood, should not be used to drill holes in hard metals.
- twist drills which are used on hard metals will have HS (high speed) or HSS (high speed steel) stamped on the shank.
- if the shank has no letter markings, it is carbon steel and should be used for drilling material other than hard metal.



Figure

d) Auger bit: - The Auger bit has a solid centre and can be used with a brace or electric drill. Bits are available in dimensions - 6 mm to 25 mm. The sizes are found on the shank of the bit.



Figure

e) Expansion bit: - This type bit is designed in such a way that it can be adjusted to the bore holes of different diameters such as 15.8 to 45.00 mm.

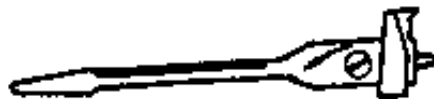

Figure

f) Countersink bit: - This bit is used to increase the diameter of the top of a drilled

hole in order to receive the head of a screw. It is conical in shape. The deeper the countersink is allowed to penetrate, the greater will be the diameter of the hole.



Figure

g) Doorlock bit: - This bit is used primarily for fitting cylinder locks. It can also be used to bore holes for pipes and conduit. Sizes are available to meet most common job requirements.

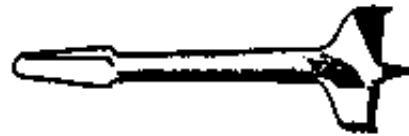

Figure

6.7. Driving tools

a) Claw hammer: - Claw hammer are used by carpenters principally for the driving in of nails to connect timber together. The claw part of the hammer is used to grip nails and to remove them from the timber. Claw hammers have wooden, steel or fibreglass handles. Claw hammers with steel or fibreglass handles are fitted with a rubber or vinyl hand grip. This type of handle is less likely to break under normal use.

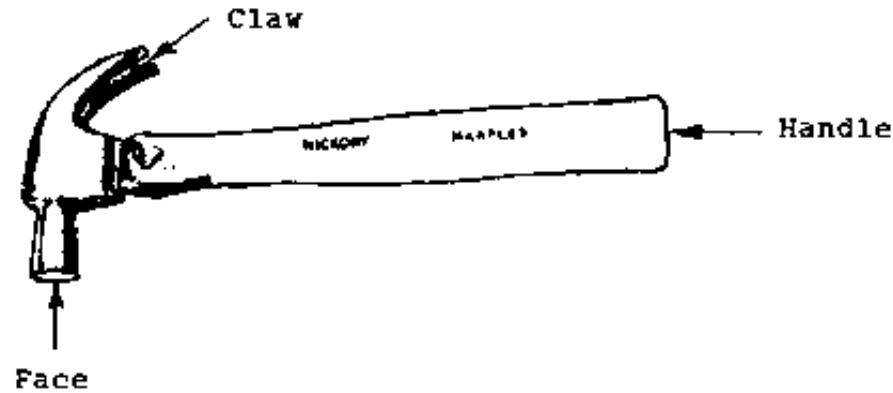

Figure

b) Screwdriver: - A screwdriver is used for driving screws. Screwdrivers are of various shape and sizes according to the work they are required to do. There are two types of screwdrivers. They are named Flat head screwdriver and Phillips screwdriver.



Figure

c) Nail Punch: - These are used for punching or "setting" the head of the nail below the surface of the timber. They are made in various sizes to suit the particular size nail being driven, they have a concave point to seat on the head of the nail.



Figure

d) Crow Bar or Pinch bar: - These bars are commonly used on building sites to remove formwork and nails. They are also used to move or position heavy construction items.

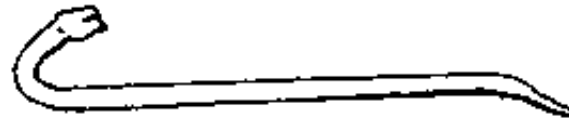

Figure

e) Tower Pincer: - These are used for the withdrawal of nails or brads, the pinching off of the points or heads of nails or for holding small metal parts while work is performed upon them.



Figure

6.8. Guiding tools

a) String: - A string is used to get a straight line.



Figure

b) Line level: - This is a short (about 75 or 100 mm) and very light level and is used in conjunction with the line above being hung on it by means of hooks at each end of the level. It is used to test the approximate levelness of height lines in foundations and care must be taken to see that it is hung exactly in the centre of the line, otherwise there will be an unequal sag in the line with consequent inaccuracy reading on the level.

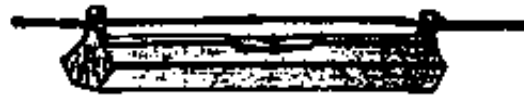

Figure

c) Plumb Bob: - A plumb bob is a metal weight with a string attached to a central hole. This instrument is used-to check the plumbness of vertical surfaces.

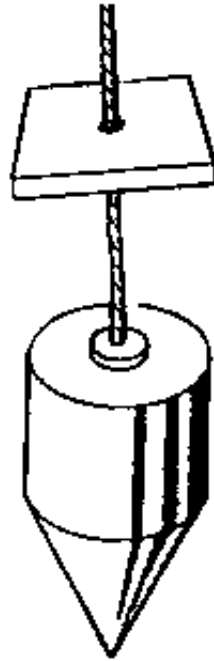

Figure

d) Spirit level: - The spirit level is a tool which is made of wood or lightweight metal. Spirit levels have at least two vials. One is used for levelling vertical surfaces, and one is used for levelling horizontal surfaces.



Figure

e) 3-4-5- method or builders square:

- Usually this method is used on the building site to prove the squareness of the corners, during the process of making the foundation. It acts like a big try square.

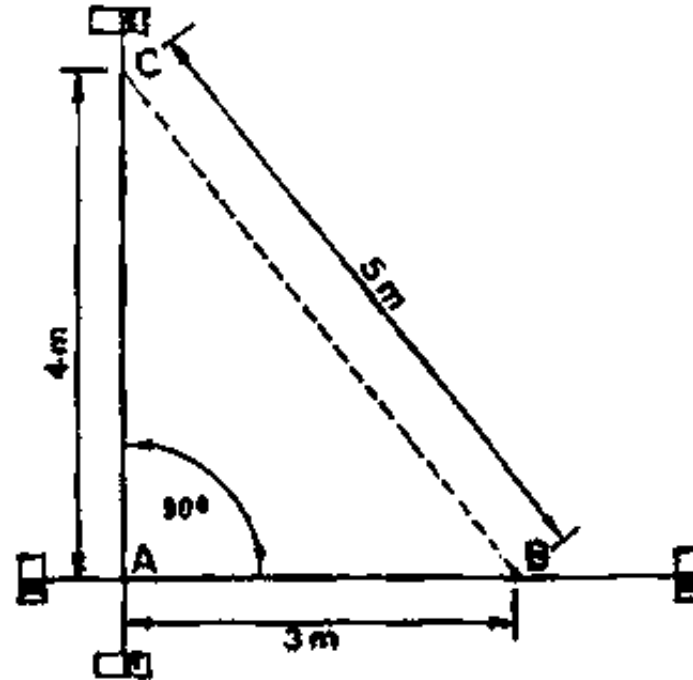

Figure

- Sometimes on the building site the 3-4-5 method is too small and you have to choose bigger distances. That would be 6-8-10. On the other hand if the 3-4-5 method is too big you use the 1.5-2-2.5 method.

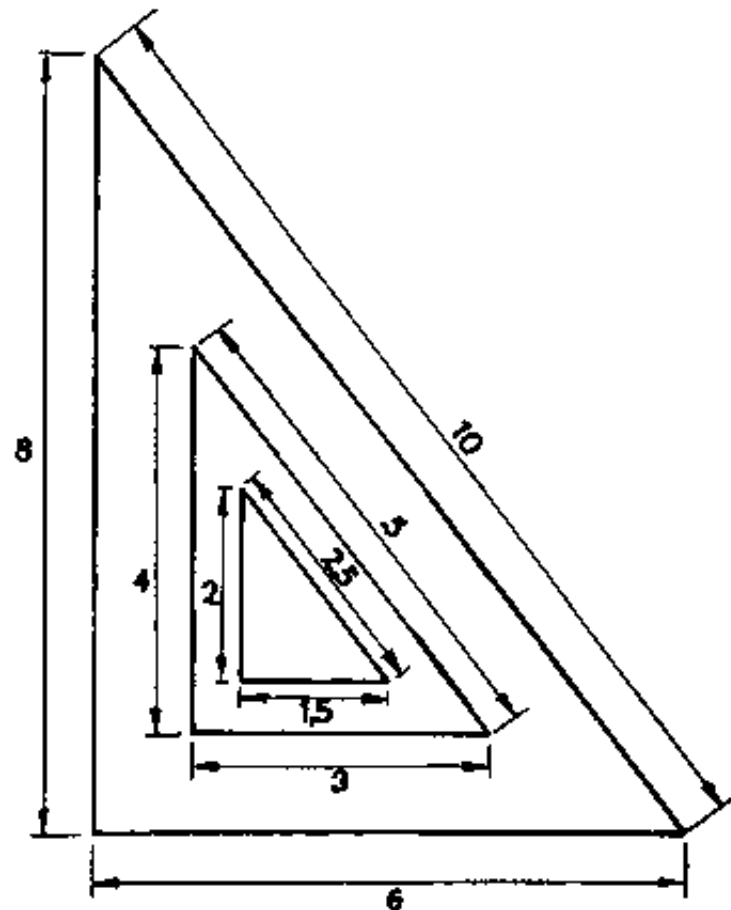

Figure

f) Water level: - The water level consists of a transparent hose and at the end plastic or glass pipes are fixed. Because still water is always level the surface of the water in the plastic or glass pipe is always level.

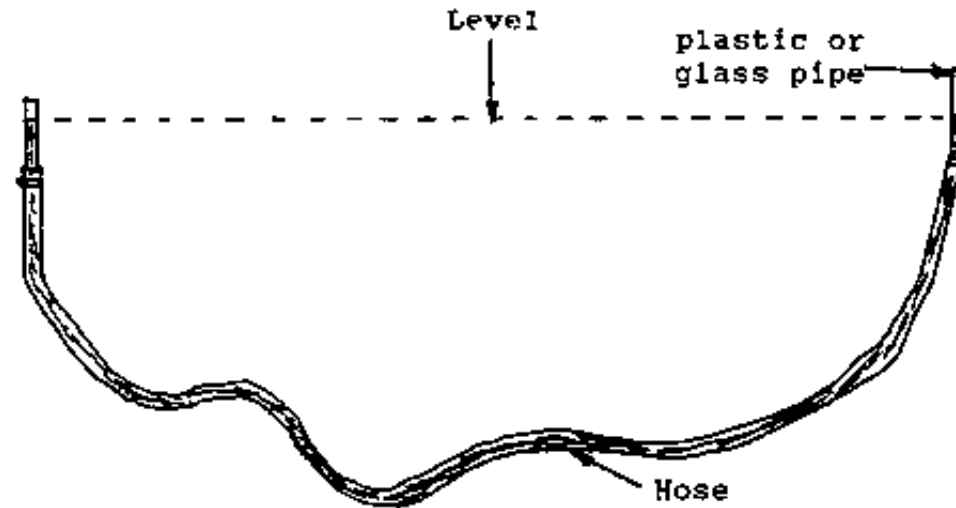

Figure

g) Straightedge: - length of timber with parallel, straight edges are used for testing the straightness of other timbers, etc..

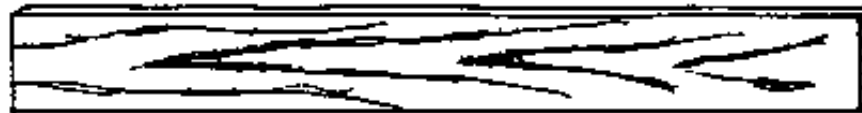

Figure

6.9. Bricklaying tools

a) Brick trowel: - This is the most important tool as it is constantly in use when spreading mortar and laying bricks. The brick trowel may also be used for roughly cutting bricks. To do this, nick the two edges of the brick in the required position with the trowel and then give it a sharp blow.

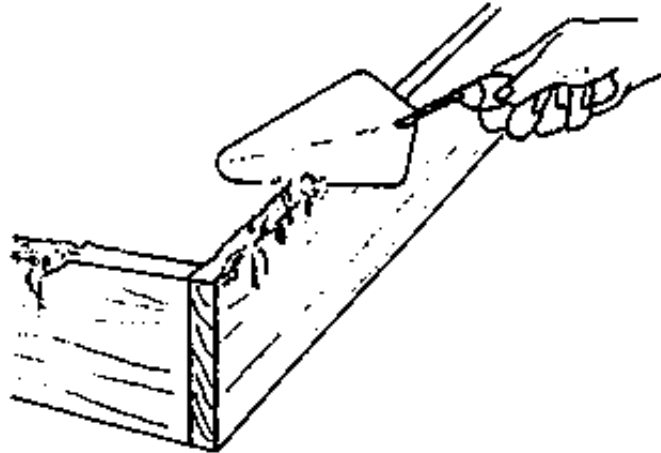

Figure

b) Brick Hammer: - The brick hammer is used for breaking, splitting, shaping and trimming masonry building units.

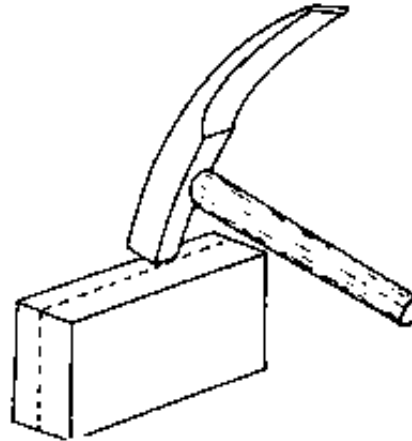

Figure

c) Jointer: - Jointer are used for finishing the exposed cross mortar joints between masonry units. Finished joints are required in order to seal the joint against moisture and present a pleasant appearance on the faced wall.

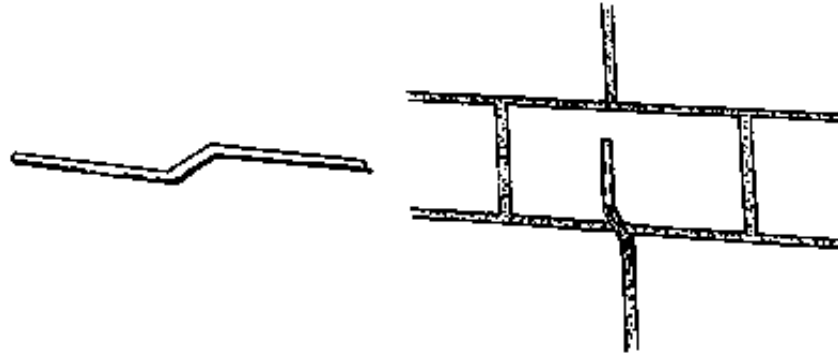

Figure

d) Runners: - Runners are used for the same purpose as jointers except that runners are used for finishing the parallel mortar joints.

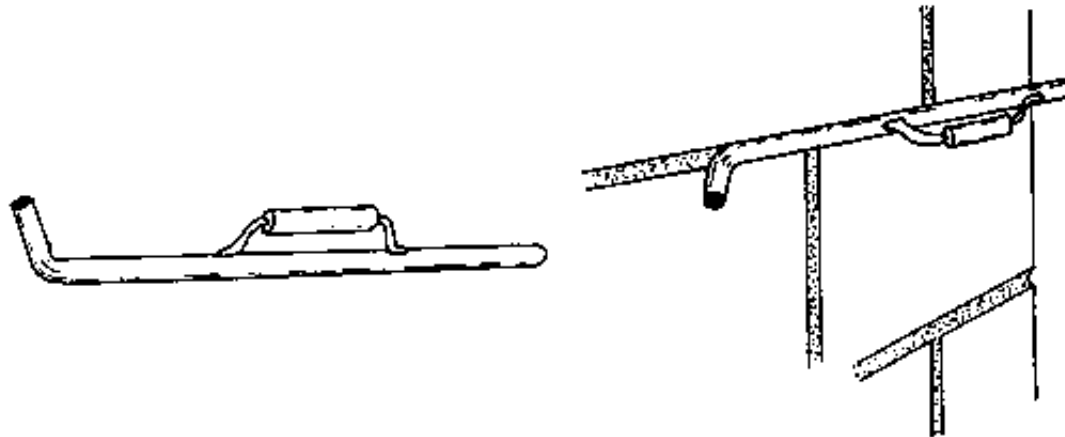

Figure

e) Brick set: - It is a type of chisel, designed for cutting bricks.

The set is used in conjunction with the club hammer.

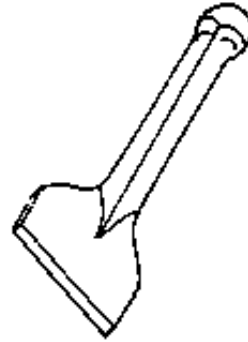

Figure

f) Club Hammer: - Club hammers are used for striking the brick set.

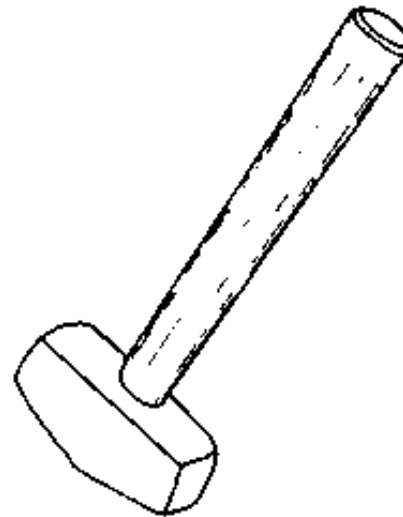

Figure

6.10. Concrete working tools

a) Float: - It is used for floating concrete.



Figure

b) Edger: - An edger is used breaking off sharp concrete edges while the concrete is firm but still moist.

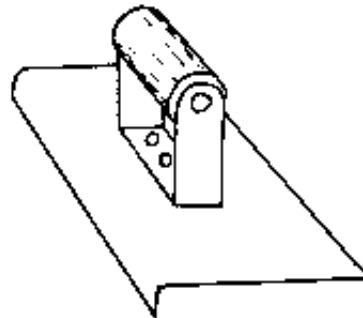

Figure

c) Groover: - A groover is used for making the control joints in large concrete slabs.

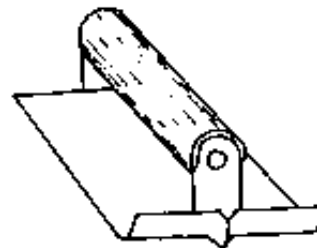

Figure

d) Showel: - Is used for shifting earth, sand, gravel etc...

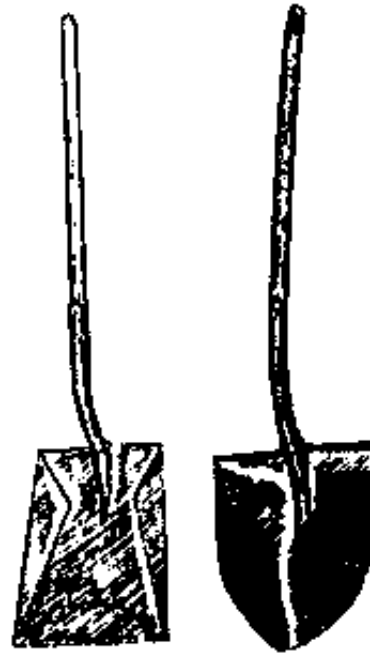

Figure







[Home](#) > [ar](#).[cn](#).[de](#).[en](#).[es](#).[fr](#).[id](#).[it](#).[ph](#).[po](#).[ru](#).[sw](#)

 **Carpentry for Vocational Schools - A Teacher's handbook (GTZ, 252 p.)**

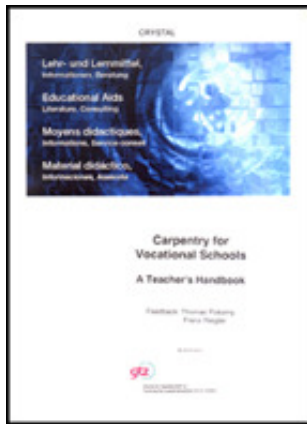
  **7. FASTENERS**

 **(introduction...)**



-  **7.1. Nails**
-  **7.2. Screws**
-  **7.3. Bolts and nuts**
-  **7.4. Building accessories**

Carpentry for Vocational Schools - A Teacher's handbook (GTZ, 252 p.)

7. FASTENERS

TOPIC: 7. FASTENERS

INTRODUCTION: Certain fasteners have certain uses.

This topic teaches students where and how to use which fasteners, their names and characteristics.

OBJECTIVES:

7.1. Students should be able to identify the different nails and their characteristics as well as being able to use them correctly.

7.2. Students should be able to recognise the different types of screws and use them in a correct way.

7.3. Students have to be able to identify the different types of bolts and nuts, state their uses and how to use them correctly.

7.4. Students should know the most important building accessories and how to apply them correctly.

METHOD: We prepare samples of all fasteners and display them in the classroom. Also samples using fasteners, can be prepared and displayed for better understanding.

Photocopies of the most important fasteners can be prepared and handed out to students after the theory lesson which have to be glued into their trade theory books.

For practical exercise, wood samples can be prepared which students join by nailing screwing or bolting. Students will see which fastener is the strongest.

NOTE: At the end of this section prepare a worksheet for students to fill in in their own time for reinforcement of this topic.

Fasteners are metal pieces for fixing members together. There are four main kinds of fasteners. They are named Nails, Screws, Bolts and Nuts and Building Accessories.

7.1. Nails

Nails are made of drawn iron wire. One end is upset and forms the nail head. The other end is pointed. Nails are used for joining wood, assembling ironwork to

wood, fastening flooring boards, wooden partitions, etc... When ordering nails you must state the Quality, the Length, the Finish, the Type eg. 25 kg 100x4,5 galvanised Flat head nails.

a) Jolt or Bullet head nail: - A strong nail giving a neat appearance when driven and punched into the wood. Widely used in buildings.



Figure

b) Flat head nail: - Wire nails are available in sizes from 13 mm to 250 mm in length and are obtainable in bright mild steel and galvanised. The shank is roughened near the head to increase the friction grip. The head is round and flat and knurled to prevent the hammer from slipping off. These nails are also known as French nails.



Figure

c) Panel pin: - Panel pins are round in cross section. They are available in sizes from 13 mm to 50 mm in length and are used for light construction. The head is easily punched beneath the surface with no damage to the wood surface surrounding the head. Available in bright steel and various coatings. Veneer pins are similar to panel pins but finer in section and are used for small mouldings and fixing veneers in position.



Figure

d) Fibro nails: - Wire nail coated with zinc to prevent it from getting rusty. A thin nail of about 15 mm to 30 mm length with flat head and blunt end.



Figure

e) Spring head or roofing nail: - An umbrella shaped type of nail which is commonly used to nail roofing iron (corrugated iron) on to the roof frames. The nail is galvanised to protect it from getting rusty.

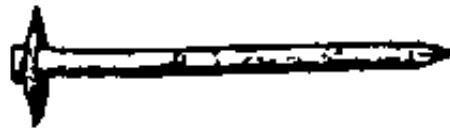

Figure

f) Clout nail: - Made in steel or copper and may be galvanized. It is round in cross section and has a large head which makes it ideal for fixing roofing felt and webbing.

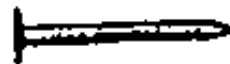

Figure

7.2. Screws

Woodscrews are used for joining wood, fastening ironwork to wood, fastening hardware (hinges, locks, catches) to wood. A screw is a metal fastener with a

spiral thread cut in. Wood-screws are made of iron, brass or other material. Screws provide much greater holding power than nails. The spiral thread of the screw turns its way into the wood to become firmly embedded in the fibres. A thread is formed in the wood and enables screws to be removed and replaced if required.

a) Parts of a screw: - A screw consists of a Slot, the Head, the Gauge, the Shank, the Thread and the Point.

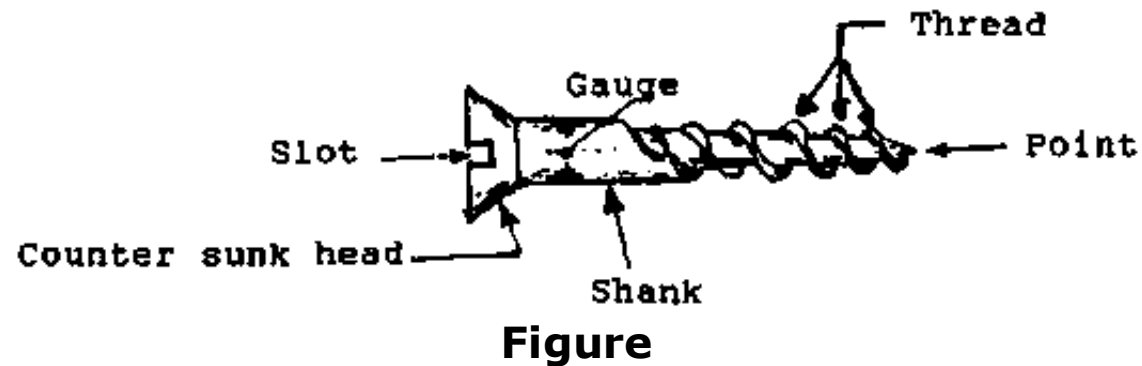

b) Different types of screws:

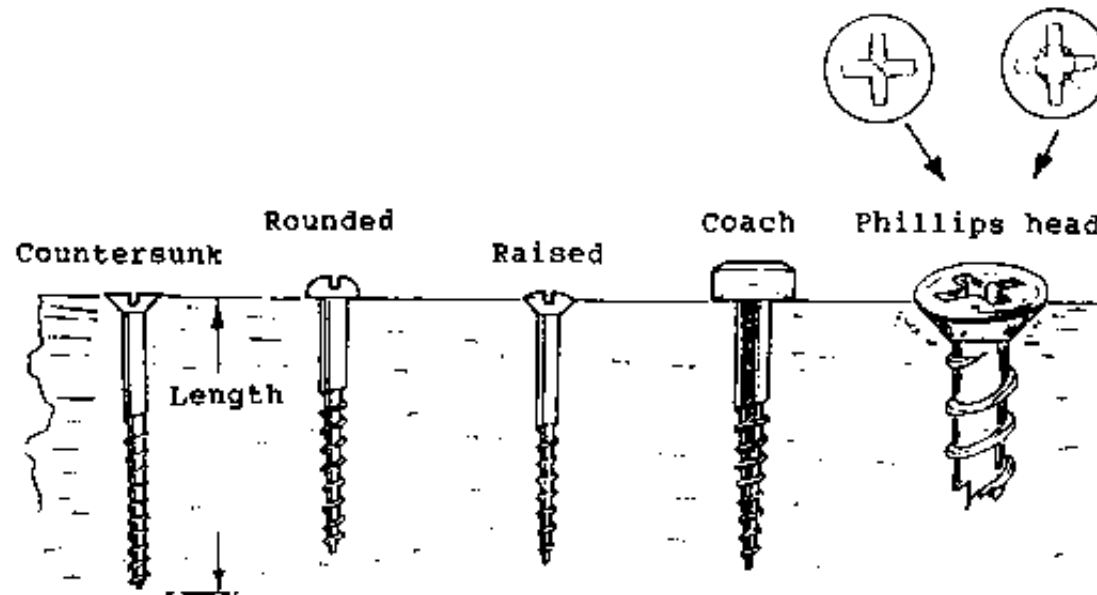

Figure

c) Fitting screws: - Softwood: It is necessary to bore a clearance hole for the shank of the screw through the top piece of wood. Countersinking will also be required for a countersunk head screw.

Hardwood: A clearance hole must be bored in the top piece and a pilot hole for the thread of the screw in the bottom piece.

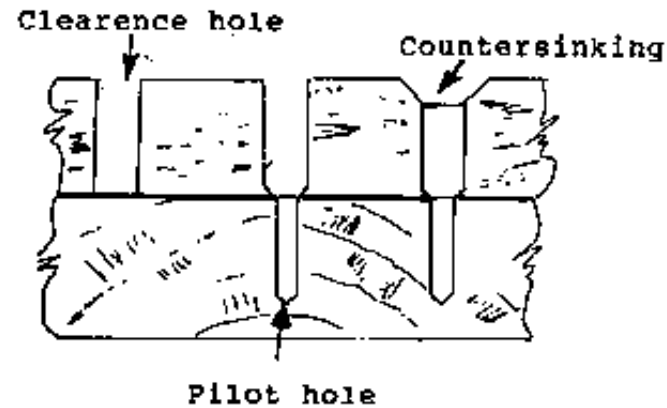

Figure

7.3. Bolts and nuts

Bolts and nuts are used for joining wood in heavy wood construction (roof trusses and rafters), fastening heavy wood structures to iron constructions, connection of parts on iron construction.

The bolt consists of a cylindrical shank with a head. The shank is threaded for a nut.

Fastening two (or more) pieces of wood by means of a bolt gives a very strong connection.

A washer is put between wood and nut to prevent damaging the wood, when the nut is tightened up.

When ordering any Bolts and Nuts you must specify the quantity, the diameter of shank, the length, the finish, the type eg. Fifteen M10 x 100 galvanised cup head bolts.

a) Coach screw: - Extra large wood screw with bolt type head that is tightened with a spanner.



Figure

b) Self-tapping screw: - Used for sheet metal work. It cuts its own thread as it is screwed. Has either slotted or Philips cross slot head.

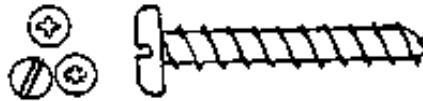

Figure

c) Machine bolts: - All bolts with square or hexagonal heads referred to as machine bolts.

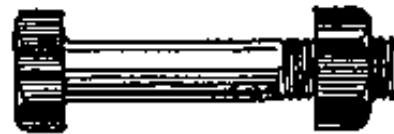

Figure

d) Coach or Carriage bolts: - All bolts with round heads are referred to as coach or carriage bolts. They have square or ribbed collars that prevent them from turning once the nut has tightened.



Figure

e) Stove bolts: - Functions as a bolt but have screw heads flat or round.



Figure

f) Rag bolt: - For bolting wood to concrete, jagged head is set in wet concrete and holds firmly when concrete dries.

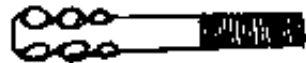

Figure

g) Hexagonal nuts: - Commonest type of nut available in a wider range of sizes.



Figure

h) Square nuts: - Mainly in large sizes only for coach bolts.



Figure

i) Flat square nuts: - In smaller sizes only for lighter jobs.



Figure

j) Handrail nut: - Used on handrail screw and in places where there is a space problem and where it is necessary for nuts to be tightened from the sides.



Figure

k) Winged nuts: - Used where nuts have to be easily undone and tightened by hand.



Figure

1) Dome nuts: - Decorative nut, usually chromium plated.



Figure

m) locking nut: - Is used where vibrations might make normal nuts undone. Has fibre ring inside to make it hard to turn.



Figure

n) Flat washer: - For round head screws, spreads the load to give good grip. Also used in conjunction with bolts to prevent bolt from falling into wood and give a smooth surface to tighten the nut on.



Figure

o) Single coil spring washer: - For fastening, spring shape prevents bolt from coming undone.



Figure

p) Tooth washer: - Washers with internal or external gripping teeth to prevent bolt from undoing.



Figure

q) Timber connector: - Used between pieces of wood bolted together to prevent slippage.



Figure

7.4. Building accessories

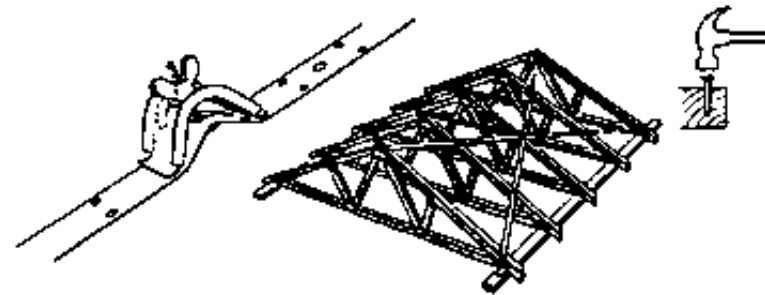

Strap Brace & Tensioners

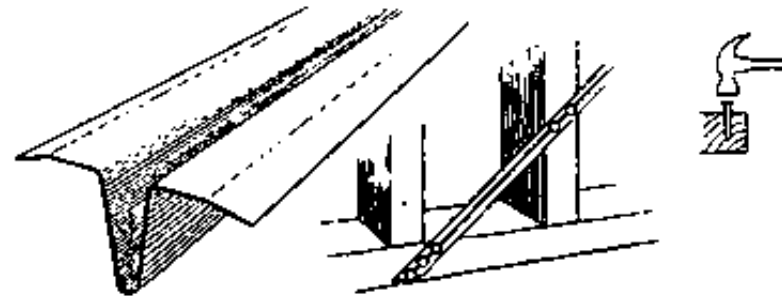

Tee Brace

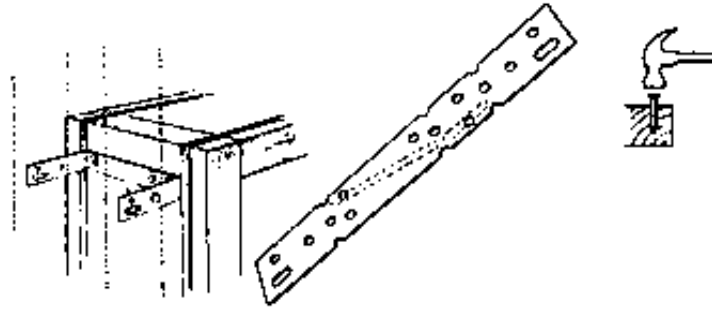

Jamb Fixa

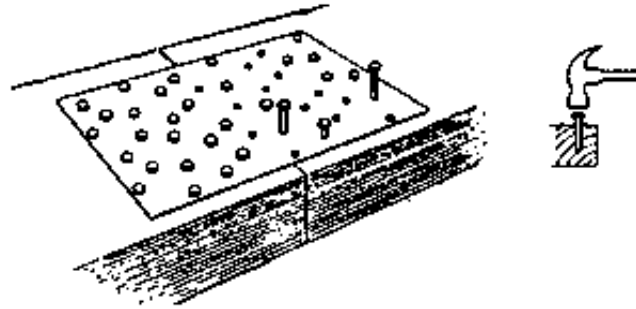

Nail-on Plates

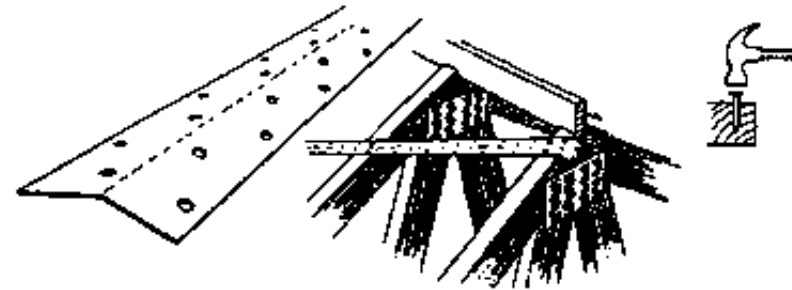

Speed Brace

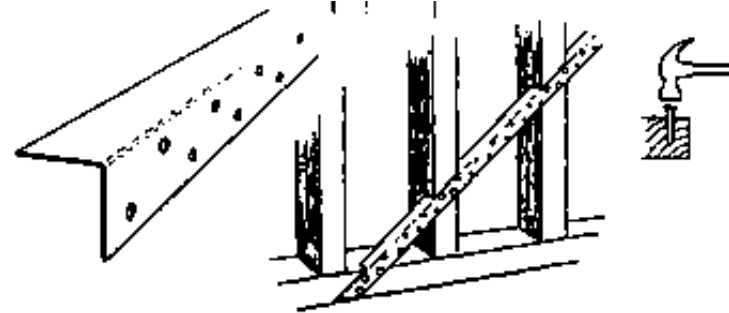

Angle Brace

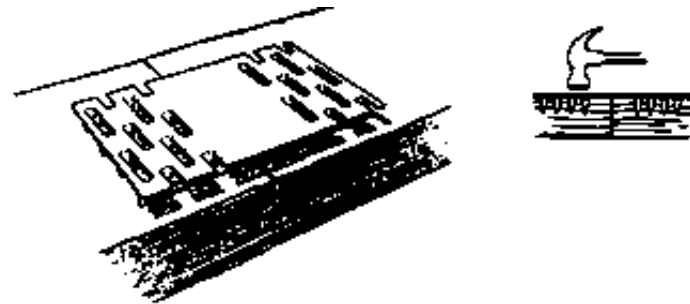

Strap Nail

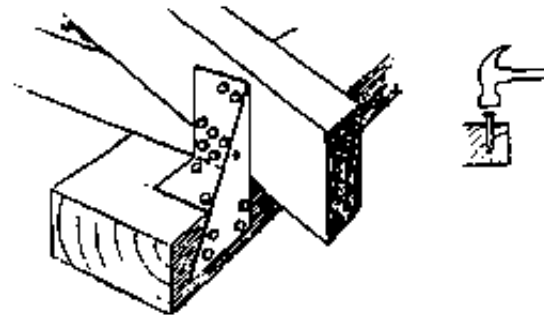

Triple Grips

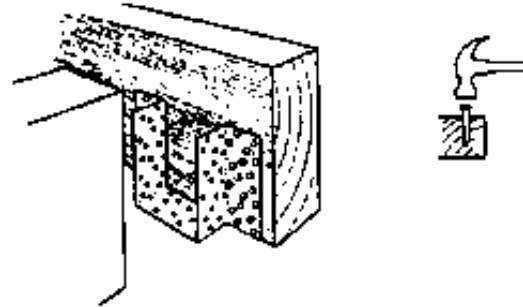

Joist Hangers

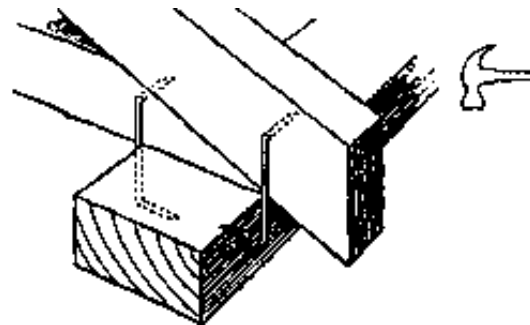

Z & U Nails

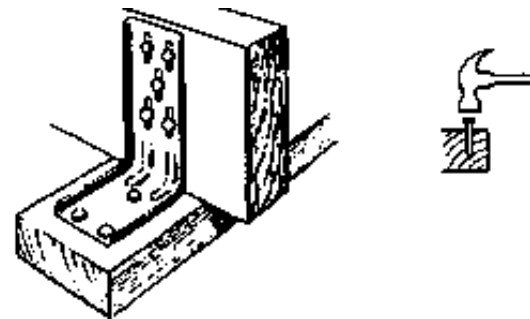

Pryda Hitch

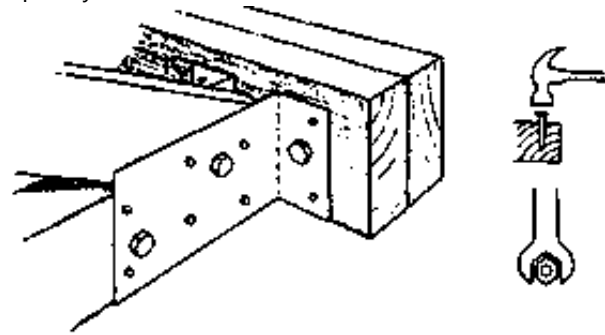

Truss Boot

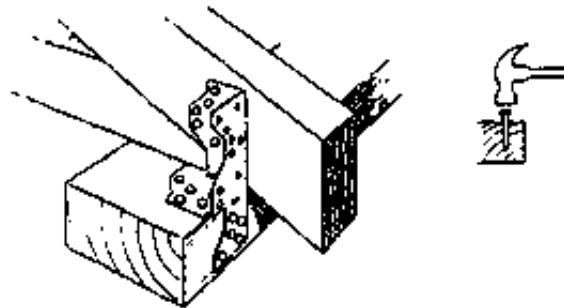

Multigrips

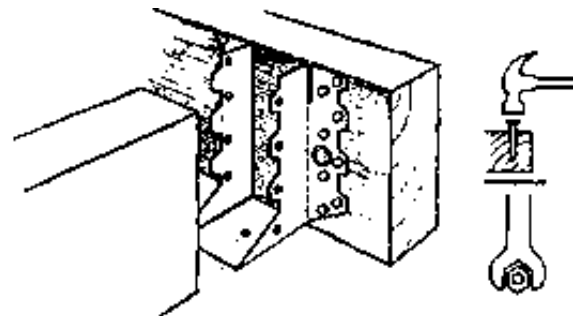

Framing Brackets

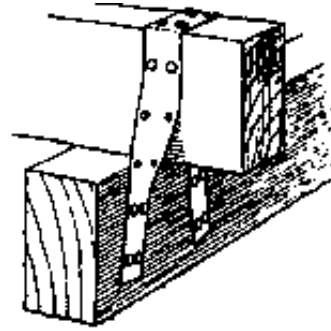

Windstrap

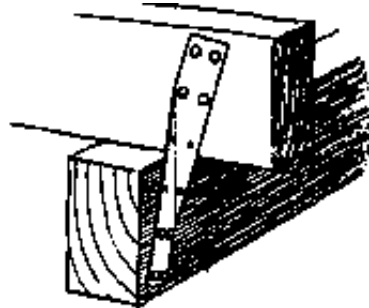

Purlin Hangers

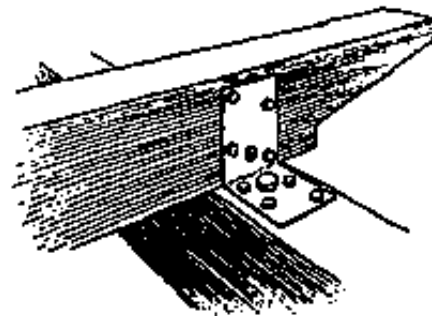

Pergola Angle

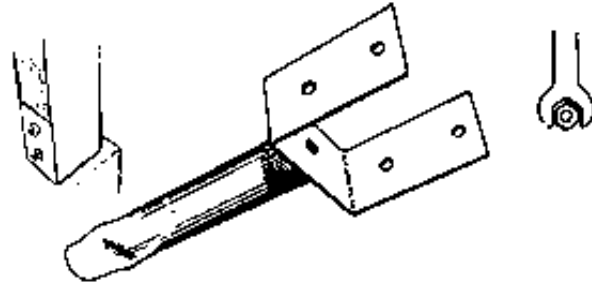

Double (W) Strength (DW4)

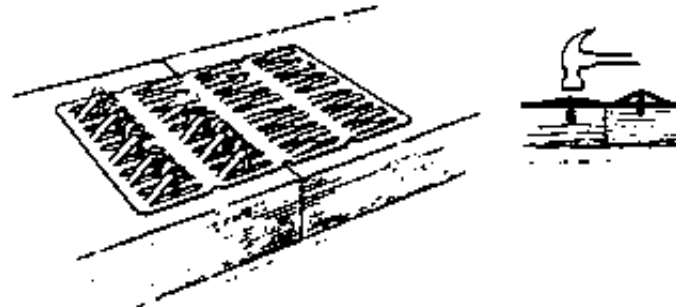

Knuckle Nailplates

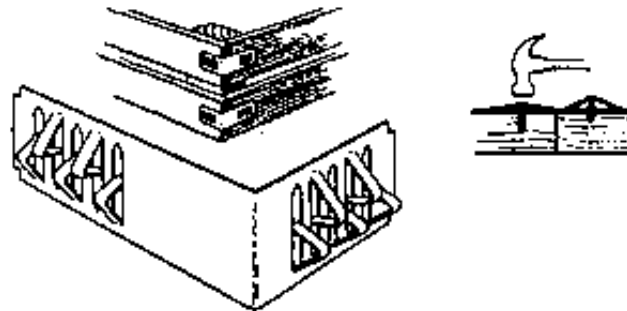

Floormate

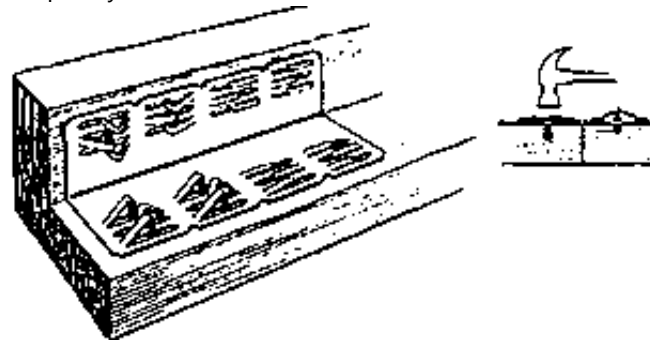

Angle Plates

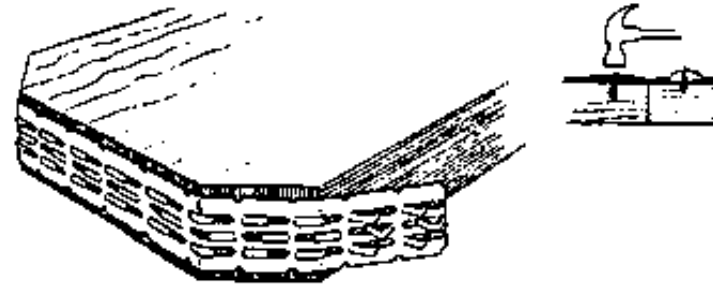

Plank Protectors

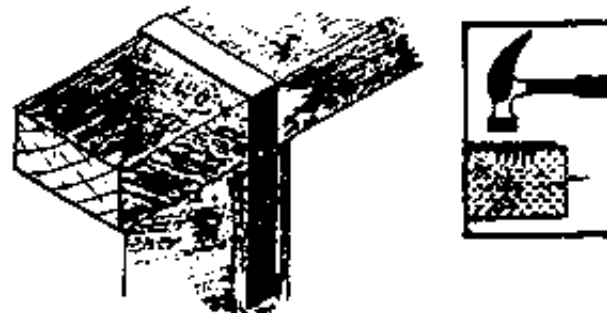

Stud Tie

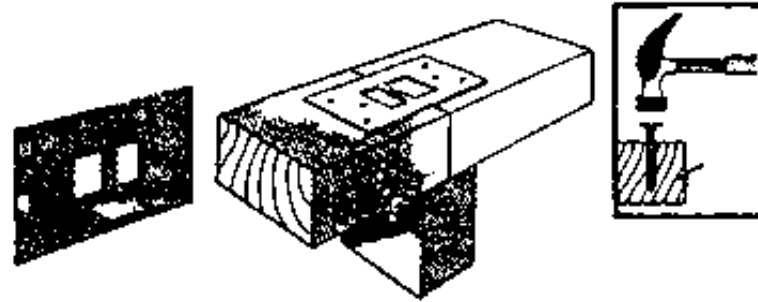

Connector Plate

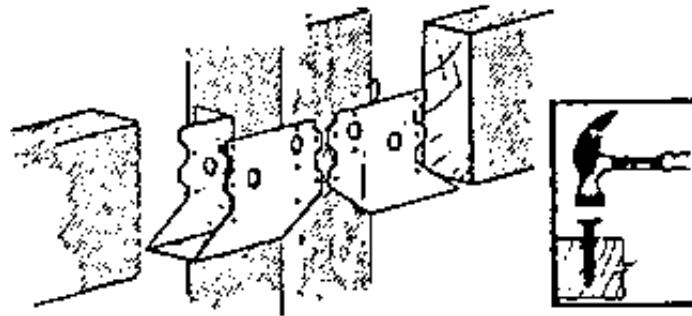

Post Rail Hanger

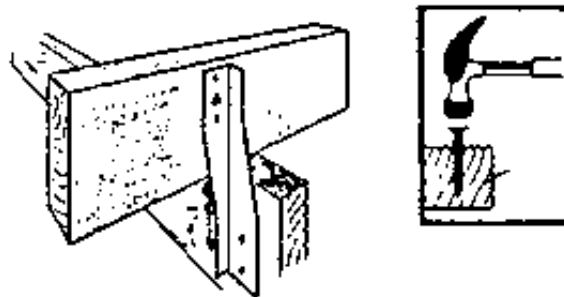

Joist Strap

