

Carpentry for Vocational Schools - A Teacher's handbook (GTZ, 252 p.)



(introduction...)



PREFACE



1. TIMBER



(introduction...)



1.1. Growth of a tree



1.2. Timber conversion



1.3. The air-seasoning of timber



1.4. Shrinkage of timber



1.5. Defects in timber



1.6. Commercial size of timber



1.7. Common timber



1.8. Specification of material



2. SCALES



3. CONCRETE



(introduction...)



3.1. Composition of concrete























3.2. Proportions for mixing concrete











































3.3. Reinforcing concrete












































3.4. Finishing concrete

- **4. CONCRETE FORMWORK**
 -  **(introduction...)**
 -  **4.1. Formwork for concrete slab**
 -  **4.2. Formwork for concrete wall**
 -  **4.3. Formwork for concrete stairs**
 -  **4.4. Formwork for septic tank**
- **5. FOOTINGS**
 -  **(introduction...)**
 -  **5.1. Correct depth and shape**
 -  **5.2. Piers or stumps**
 -  **5.3. Correct embedding of piers or stumps**
 -  **5.4. Finish**
 -  **5.5. Strip footing on concrete block wall**
 -  **5.6. Control joints for concrete block wall**
 -  **5.7. Applying mortar to a block**
 -  **5.8. Strip footing on masonry (concrete) wall**
 -  **5.9. Different types of strip footing**
- **6. TOOLS USED ON BUILDINGS**
 -  **(introduction...)**
 -  **6.1. Marking out tools**
 -  **6.2. Sharp edge cutting tools**
 -  **6.3. Maintenance of chisel and plane iron**
 -  **6.4. Tooth cutting tools**













-  **6.5. Maintenance of crosscut saw and rip saw**
-  **6.6. Boring tools**
-  **6.7. Driving tools**
-  **6.8. Guiding tools**
-  **6.9. Bricklaying tools**
-  **6.10. Concrete working tools**
-  **7. FASTENERS**
 -  *(introduction...)*
 -  **7.1. Nails**
 -  **7.2. Screws**
 -  **7.3. Bolts and nuts**
 -  **7.4. Building accessories**
-  **8. FOUNDATION**
 -  *(introduction...)*
 -  **8.1. Setting out side**
 -  **8.2. Setting out profile**
 -  **8.3. Fixing posts or stumps**
 -  **8.4. Bearers**
 -  **8.5. Joists**
-  **9. JOINTS**
-  **10. BRACING**
 -  *(introduction...)*

-  **10.1. Structurally**
-  **10.2. Wallframe**
-  **10.3. Braces**
- 11. WALLFRAME**
 -  *(introduction...)*
 -  **11.1 Parts of a wallframe**
 -  **11.2. Procedure of making a wallframe**
 -  **11.3. Erecting a wallframes**
- 12. CEILING**
 -  *(introduction...)*
 -  **12.1. Ceiling joists**
 -  **12.2. Purpose of the ceiling joists**
 -  **12.3. Joining ceiling joists**
 -  **12.4. Ceiling joists used as part of a roof truss**
 -  **12.5. Hanger**
 -  **12.6. Manhole**
 -  **12.7. Stairway**
- 13. ROOFING**
 -  *(introduction...)*
 -  **13.1. Different roof shapes**
 -  **13.2. Technical terms of a roof**
 -  **13.3. Rafter and ridge roof**
 -  **13.4. Roof truss**
 -  **13.5. Diagonal roof bracing**

-  **13.6. Roofing iron**
-  **13.7. Laying of roofing iron**
-  **13.8. Finishing a roof**
-  **14. WINDOWS**
 -  *(introduction...)*
 -  **14.1. Parts of a window frame**
 -  **14.2. Calculating of a window opening**
 -  **14.3. Joining a window frame**
 -  **14.4. Fixing a window frame**
-  **15. OUTSIDE CLADDING**
 -  *(introduction...)*
 -  **15.1. Timber weather boards**
 -  **15.2. Fibre cement boards**
 -  **15.3. "V" crimp iron**
-  **16. FLOORING**
 -  *(introduction...)*
 -  **16.1. Different types of flooring boards**
 -  **16.2. Laying of flooring boards**
 -  **16.3. Finishing of flooring**
-  **17. ELECTRICITY**
 -  *(introduction...)*
 -  **17.1. Basic knowledge**

-  **17.2. Fuse box**
-  **17.3. Electricity accessories**
-  **17.4. How to connect switch, power point, light and power plug**
-  **17.5. Simple house wiring**
-  **17.6. Alternate switching**
- **18. PLUMBING**
 -  **(introduction...)**
 -  **18.1. Water pipes**
 -  **18.2. Plumbing tools**
 -  **18.3. Plumbing fittings**
 -  **18.4. Guidelines for plumbing**
- **19. INSIDE CLADDING**
 -  **(introduction...)**
 -  **19.1. Plywood painted**
 -  **19.2. Plywood varnished**
- **20. DOORS**
 -  **(introduction...)**
 -  **20.1. Door frame**
 -  **20.2. Calculating of opening**
 -  **20.3. Fixing door jambs**
 -  **20.4. Hanging a door**
 -  **20.5. Types of doors**

- **21. SKIRTING, ARCHITRAVES, CORNERSTRIPS**
 - 📄 *(introduction...)*
 - 📄 **21.1. Shapes**
 - 📄 **21.2. Cutting and joining**
- **22. PAINTING**
 - 📄 *(introduction...)*
 - 📄 **22.1. Types of paint**
 - 📄 **22.2. Finishes**
 - 📄 **22.3. Colours**
 - 📄 **22.4. Methods of applications**
 - 📄 **22.5. Tools and materials**
 - 📄 **22.6. Preparations**
 - 📄 **22.7. Painting**
 - 📄 **22.8. How to ensure a perfect finish**
 - 📄 **22.9. Cleaning up**
- **23. STAIRS**
 - 📄 *(introduction...)*
 - 📄 **23.1. Technical terms of a stair**
 - 📄 **23.2. Parts of a stair**
 - 📄 **23.3. Calculating the number and size of steps**
 - 📄 **23.4. Calculating the width of the stringers**
 - 📄 **23.5. Marking out stringers**
 - 📄 **23.6. Marking out top and bottom end of stringers**

-  **23.7. Joining and assembling stairs**
-  **23.8. Fixing stairs**
-  **23.9. External stairs**
-  **23.10. Concrete stairs**
- **24. HARDWARE**
 -  *(introduction...)*
 -  **24.1. Locks**
 -  **24.2. Hinges**
- **25. WATERTANKS**
 -  *(introduction...)*
 -  **25.1. Sizes of watertanks**
 -  **25.2. Watertank foundations**
 -  **25.3. Ferrocement tanks**
 -  **25.4. Maintenance and treatment of watertanks**
-  **BIBLIOGRAPHY**



[Home](#) > [ar](#).[cn](#).[de](#).[en](#).[es](#).[fr](#).[id](#).[it](#).[ph](#).[po](#).[ru](#).[sw](#)

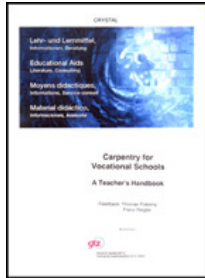
 **Carpentry for Vocational Schools - A Teacher's handbook (GTZ, 252 p.)**

➔  *(introduction...)*

 **PREFACE**

□ **1. TIMBER**

 **2. SCALES**



- 3. CONCRETE**
- 4. CONCRETE FORMWORK**
- 5. FOOTINGS**
- 6. TOOLS USED ON BUILDINGS**
- 7. FASTENERS**
- 8. FOUNDATION**
- 9. JOINTS**
- 10. BRACING**
- 11. WALLFRAME**
- 12. CEILING**
- 13. ROOFING**
- 14. WINDOWS**
- 15. OUTSIDE CLADDING**
- 16. FLOORING**
- 17. ELECTRICITY**
- 18. PLUMBING**
- 19. INSIDE CLADDING**
- 20. DOORS**
- 21. SKIRTING, ARCHITRAVES, CORNERSTRIPS**
- 22. PAINTING**
- 23. STAIRS**
- 24. HARDWARE**
- 25. WATERTANKS**



BIBLIOGRAPHY

Feedback:

**Thomas Pokorny
Franz Riegler**

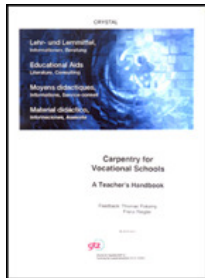
95-34-0105/2

**THOMAS POKORNY
FRANZ RIEGLER**

Deutsche Gesellschaft fr Technische Zusammenarbeit (GTZ) GmbH



[Home](#)"" """"> [ar.cn.de.en.es.fr.id.it.ph.po.ru.sw](#)



 **Carpentry for Vocational Schools - A Teacher's handbook (GTZ, 252 p.)**

➔  **8. FOUNDATION**

 **(introduction...)**

 **8.1. Setting out side**

 **8.2. Setting out profile**

 **8.3. Fixing posts or stumps**

 **8.4. Bearers**

 **8.5. Joists**

Carpentry for Vocational Schools - A Teacher's handbook (GTZ, 252 p.)

8. FOUNDATION

TOPIC: 8. FOUNDATION

INTRODUCTION: This topic teaches students how to level a building site, the correct setting out of a profile, the way post or stumps are fixed and how bearer and joist are fitted on top of the posts.

Because of the importance of this topic it is advised to go through this section very slow.

OBJECTIVES:

8.1. Students must be able to set out a site independently and locate the place for a building.

8.2. Students have to know why a profile has to be made and how it is made.

8.3. Students must know how to erect stumps or posts exactly vertical and in line with the other stumps.

8.4. Students should know the correct size of bearers, how they are connected to the posts or stumps and how bearers are joined and straightened if necessary.

8.5. Students should know how joists are fixed on top of bearers, the size of the joists and in which direction joists are laid and how joists can be joined if

necessary.

METHOD: First we teach this topic in the classroom. Students use their trade theory book for copying down notes and drawings from the blackboard.

This topic should be demonstrated practically for better understanding.

8.1. We select a place near the school where students mark the boundary line.

8.2. We prepare all the material (pegs, boards tools and nails) and let students do the setting out of a profile for a house about 6 m x 8 m.

8.3. This job is difficult to demonstrate and if there is no building project going on, we can prepare a model of a stump foundation in a scale of 1 : 10 and demonstrate the procedure of fixing posts on this model.

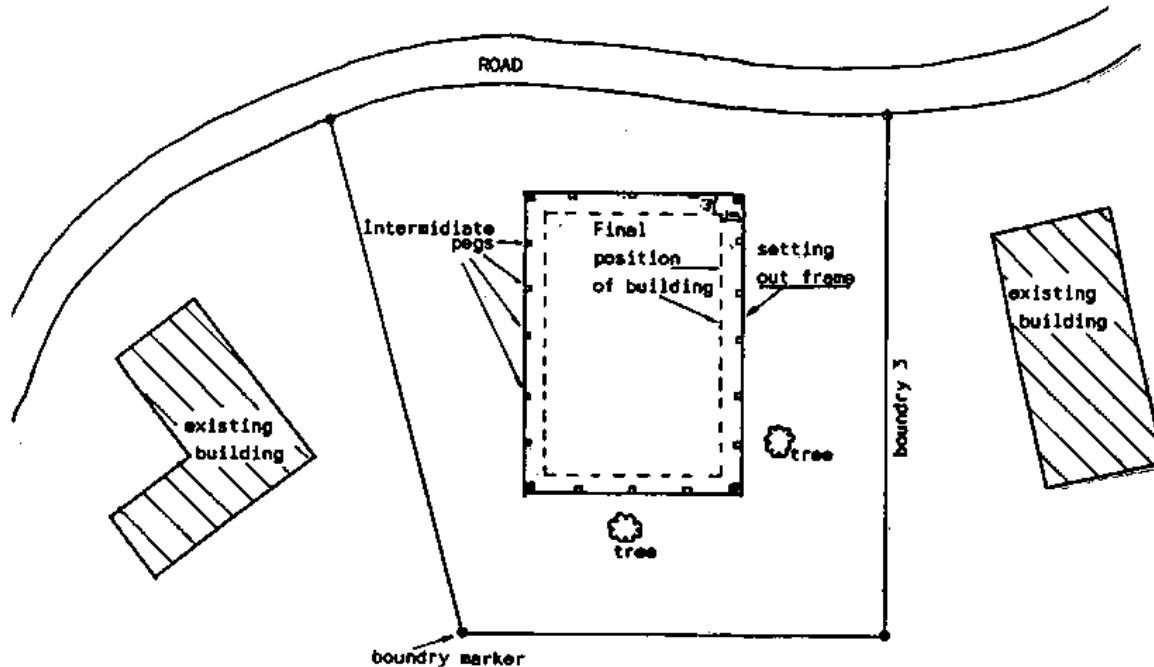
8.4. If there is no opportunity of demonstrating this job on a building site, use the model of the stump foundation to continue by laying and joining the bearers in the scale of 1 : 10.

8.5. Also laying the joists can be demonstrated on the same model in the scale of 1 : 10.

NOTE: For better understanding and for reinforcement of this topic, prepare a worksheet and hand it out at the end of this topic for the students to fill in and correct and assess it later.

8.1. Setting out side

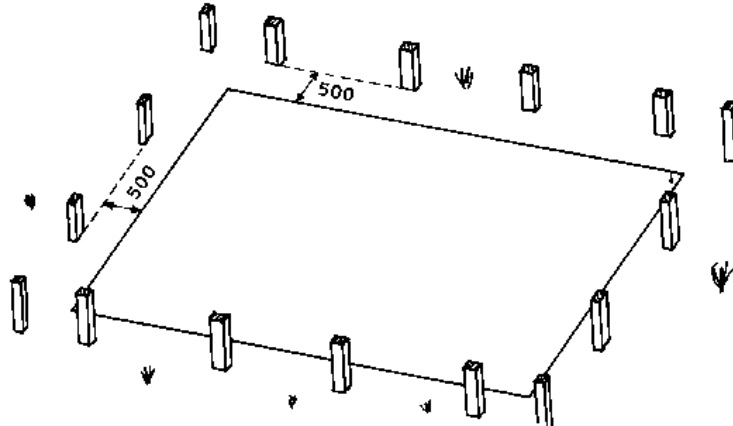
If the distance to a fence or other building is too far away there has to be set out a boundary line. If the ground has a fall, select the highest corner and place the boundary line on this side. Boundary markers are positioned by survey pegs.



Figure

8.2. Setting out profile

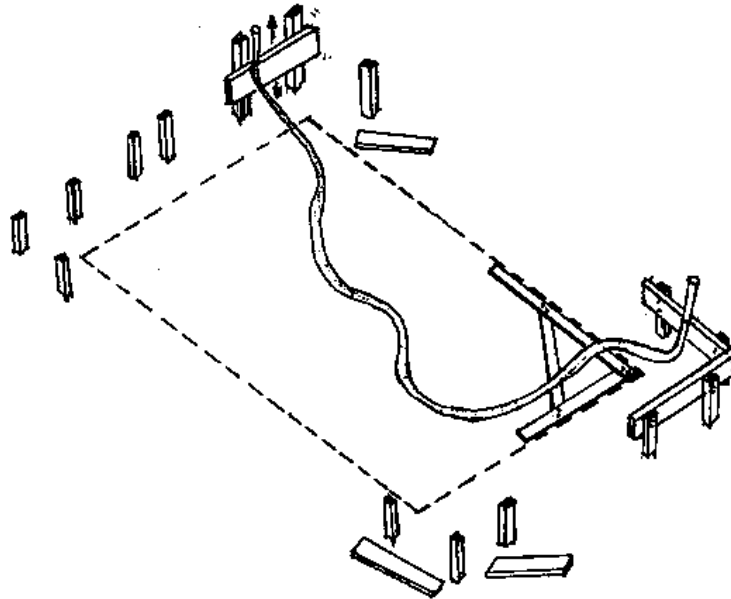
a) Pegs: - The pegs have to be driven in **500 mm** outside the final position of the building.



Figure

b) Batterboard:

- prepare the batterboards and select the corner at the highest ground level. Fix the boards about 500 mm above the soil for any kind of stump foundation. For concrete foundation fix the boards approximately 200 mm above the soil.
- When this is done, take a waterlevel or straight edge and put in the batterboards at the next corner. You find the level of this batterboard from the first one. If the batterboard is in the right position, mark it and nail the batterboard to the peg.



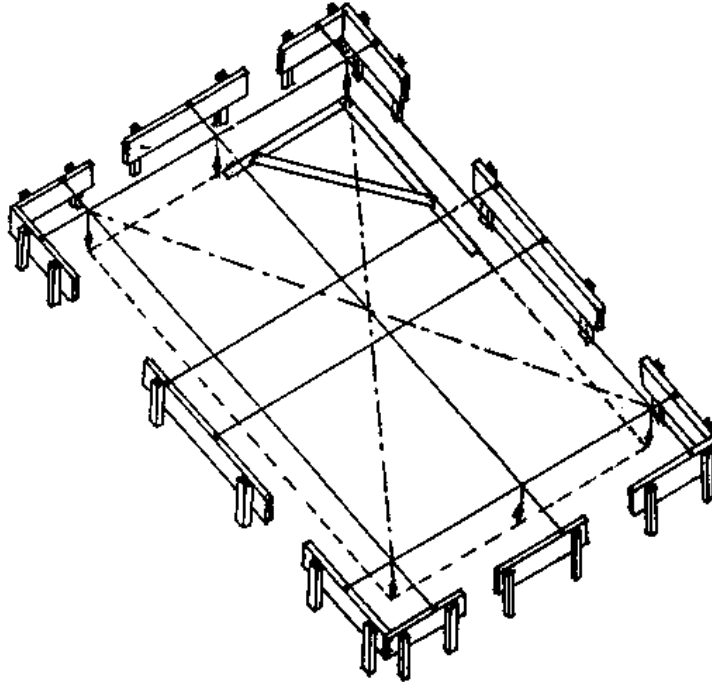
Figure

c) Stretching strings:

- The line is parallel to the boundary line.
- The second line squared off the first line. For squareness check with the 3-4-5 method.
- Now the depth of the building is measured along the second line. The third

line is parallel to the first line.

- **The next step is to measure along the third line to find the right position for the fourth line. Check for length along the fourth line. The length of the fourth line has to be equal to the length of the second line.**
- **Check across diagonally, to see if the lines are squared.**
- **Fix lines for the position of bearers.**
- **Mark the position of the stump or post holes with the aid of a plumb bob on the soil. Remove the strings and dig out the holes.**
- **The size of the hole, which has now to be dug out should be about 400 mm x 400 mm. The depth depends on the length of the stumps or posts, but it should not be less than 550 mm.**



Figure

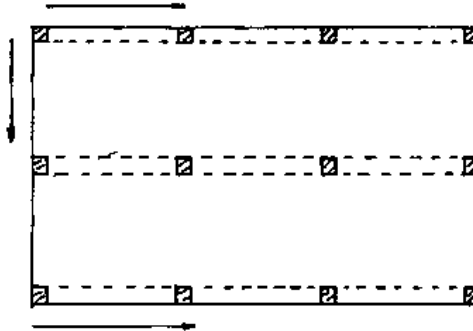
8.3. Fixing posts or stumps

Erect a corner stump first. If the ground has been levelled it is immaterial from which corner you start, but if the ground has a fall, select the highest corner. Set a post or stump in position so that it stands plumb without support and just touching the building lines. Set out one side row first, then a row at right angles. After this, set out

as convenient, but check the level of the diagonal, as well as around the outside.

Levelling is done with a straight-edge and a spirit level. Level to the stump which is as far away as the straight-edge will allow, work thus along the row, and fill in the in-between stumps afterwards.

Tall posts or stumps which exceed 1000 mm have to be braced.



Figure

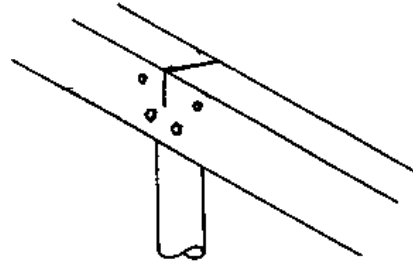
8.4. Bearers

While bearers are bolted to the post, piers or stumps, make a check with the spirit level, to see if the stumps are in the required height. Do not cut off the ends, this can be done later.

Generally it will be found that due to the side bend of bearers, the rows of the posts or stumps will now be slightly out of line. Straighten this out when floor joists are fixed.

Bearers can be 50 mm - 100 mm wide and 150 mm - 200 mm high.

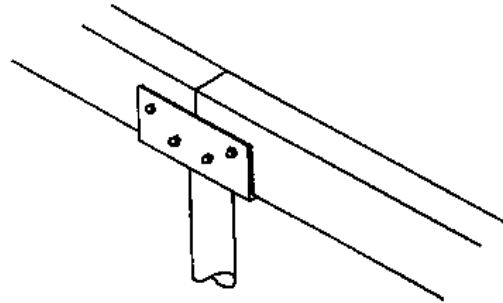
a) Straightening bearers: - When necessary, to straighten a bearer saw the bearer diagonally across and bolt it to the pier or post.



Figure

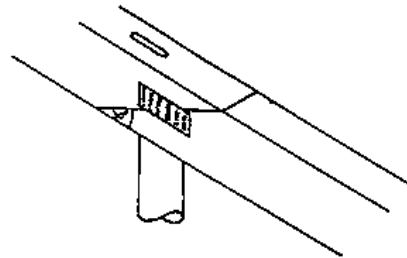
Joining bearers:

- As it is difficult and expensive to buy timber long enough for bearers to go from one end of a building to another it is necessary to join the timber. The best way to do this is to butt the two ends together over a pier and bolt them to the pier angle plate.



Figure

- If there is no plate for support join the bearers and fix a nail plate to each side of the bearer.



Figure

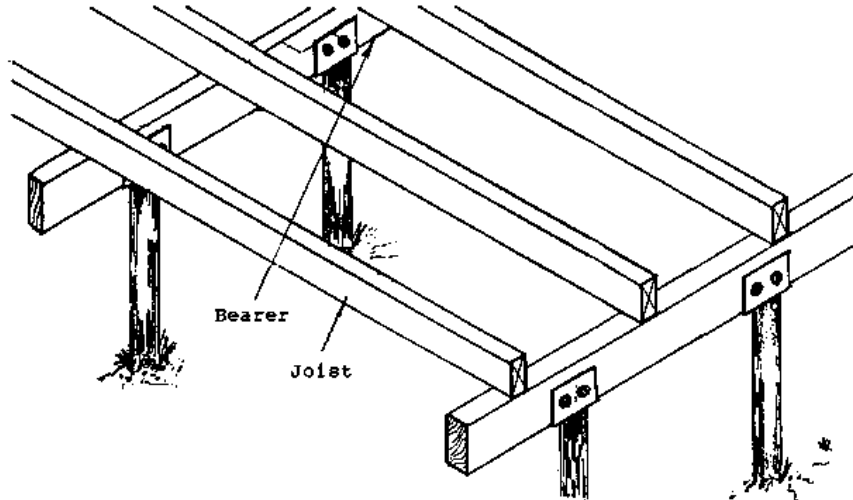
8.5. Joists

The length of timber laid across the bearers are called joists. Joists should not be packed under to bring them to a level surface, but if a small amount of packing is needed on individual joists, this may be done with hardboard or plywood .

Floor joists are spaced between 500 mm and 700 mm (centre to centre) apart. If there is a wall erected on a joist, you have to double the joist and space it 25 mm apart for outside walls. For inside walls you have to space them 50 mm apart.

The fixing of the floor joists is a most important operation. The top surface of the joists serve as a base for the walls, as well as for the flooring, so the aim is to finish with a surface which is absolutely flat and level.

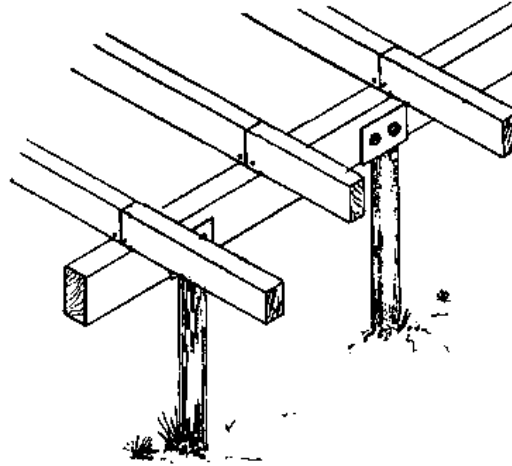
Make sure that the top edge is perfectly straight and that the joists are at the right angle to the bearers. When nailing each joist, look along it and take out any side bend.



Figure

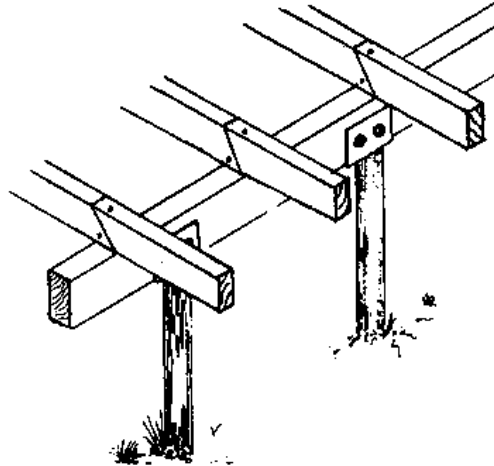
a) Joining Joists:

- **Generally joists are joint together with a butt joint.**



Figure

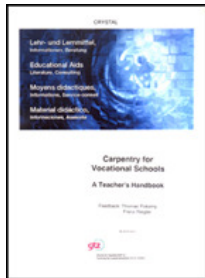
- **Sometimes a splayed joint is used to join joists together.**



Figure



[Home](#) > [ar](#) [cn](#) [de](#) [en](#) [es](#) [fr](#) [id](#) [it](#) [ph](#) [po](#) [ru](#) [sw](#)



 **Carpentry for Vocational Schools - A Teacher's handbook (GTZ, 252 p.)**



 **(introduction...)**

 **PREFACE**

 **1. TIMBER**

 **2. SCALES**

 **3. CONCRETE**

- 4. CONCRETE FORMWORK**
- 5. FOOTINGS**
- 6. TOOLS USED ON BUILDINGS**
- 7. FASTENERS**
- 8. FOUNDATION**
-  **9. JOINTS**
- 10. BRACING**
- 11. WALLFRAME**
- 12. CEILING**
- 13. ROOFING**
- 14. WINDOWS**
- 15. OUTSIDE CLADDING**
- 16. FLOORING**
- 17. ELECTRICITY**
- 18. PLUMBING**
- 19. INSIDE CLADDING**
- 20. DOORS**
- 21. SKIRTING, ARCHITRAVES, CORNERSTRIPS**
- 22. PAINTING**
- 23. STAIRS**
- 24. HARDWARE**
- 25. WATERTANKS**
-  **BIBLIOGRAPHY**

9. JOINTS

TOPIC: 9. JOINTS

INTRODUCTION: Joints are a very important part in building construction and much of the strength of a building depends on how well joints are made.

This topic teaches students the different types of joints, where they can be applied and how they are made.

OBJECTIVES:

- Students should be able to identify joints, define their characteristics and uses and be able to make some joints independently.
- Students should know that joints are the weakest spot in every timber construction and therefore always choose the proper joint.

METHOD: First we teach this topic in the classroom and students copy down notes and drawings from the blackboard in their trade theory book.

Prepare joints and display them in the classroom.

When possible show students different types of joints on buildings and furniture.

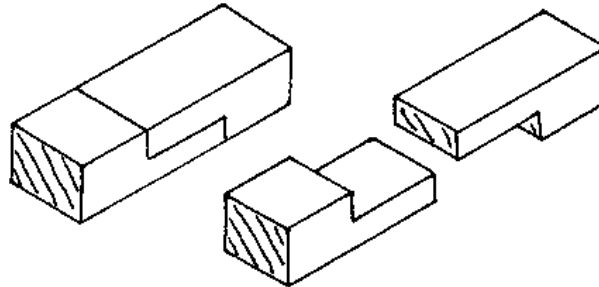
If enough time is available prepare some timber in the workshop and students can make one or two common joints.

NOTE: We prepare a worksheet at the end of this section to reinforce the lessons.

If timber is too short or two timber ends meet in a corner, there has to be joint.

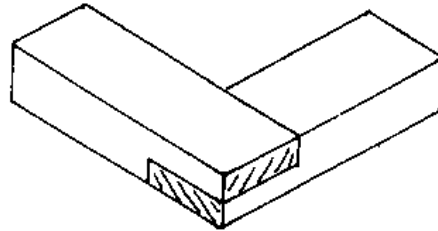
a) Halving joint:

- **A halving joint is a joint which forms the junction between two members. Half a thickness is taken out of each member so that when fitted together the surfaces are flush.**
- **Halved scarf joint: The simplest but also the weakest is the halved scarfed joint. This joint is a lengthening joint, the length of the scarf is about three times the height of the timber. The halved scarf joint is used when both parts are supported in the full length.**

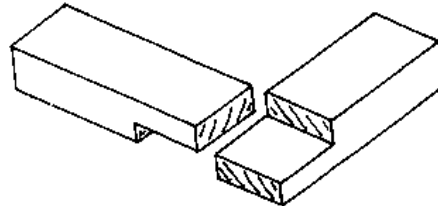


Figure

- **Corner halving: The corner halving is used on an external corner where two timbers meet, not necessarily at a right angle, but where their surfaces finish flush.**

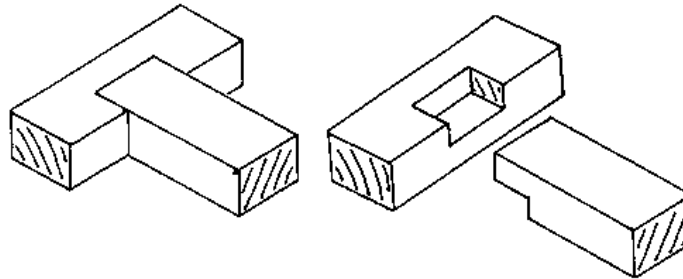


Figure



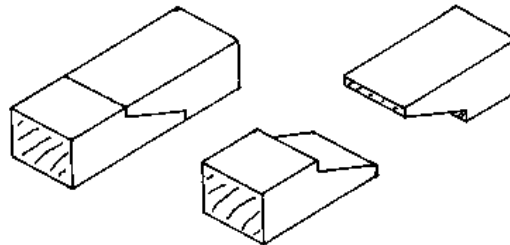
Figure

- Stopped halving: Stopped halving is used where one piece meets another anywhere along its length and so forms the letter T. Stopped halving is checked out on one piece, only half its width and half its thickness, so that this piece is not weakened as much as when it is checked right through its width.



Figure

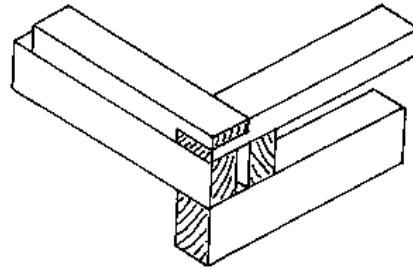
- **Splayed halving joint: Is used for extending timbers lengthwise and should only be made over another supporting timber. You have to nail nailplates to each side.**



Figure

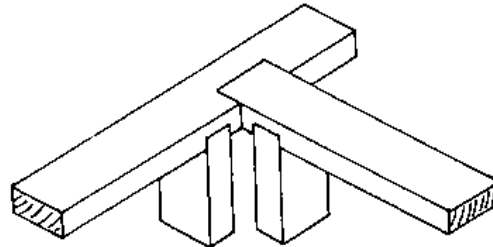
b) Where to use halving joints:

- **The halving joint is used for corner plates.**



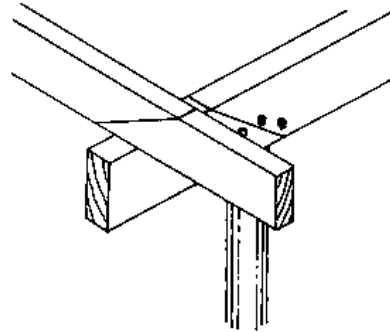
Figure

- For top and partition plates.

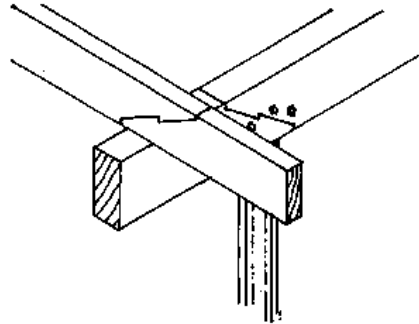


Figure

- Splayed halving joint for bearers joists and rafters.



Figure

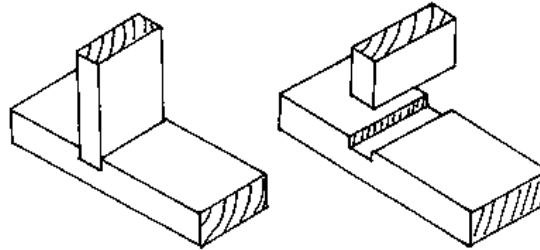


Figure

c) Housing joint:

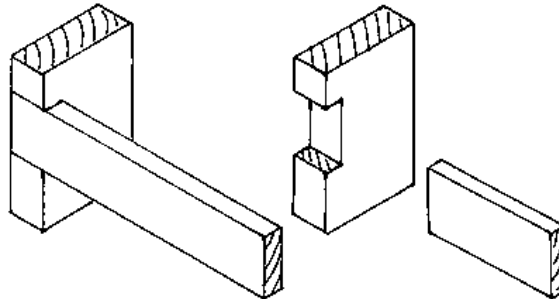
- The through housing joint: The through housing joint is mainly used on construction work where the appearance of the joint is not important. It has the whole edge or end of one piece sunk into the side of another piece, which

gives a definite positioning of the one to the other.



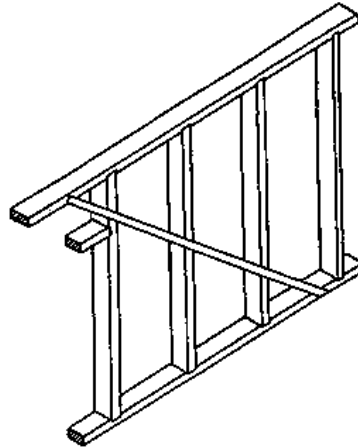
Figure

- The side housing joint: The side housing joint is where the vertical member is recessed to receive the end of an horizontal member which is usually fixed on edge to the job.



Figure

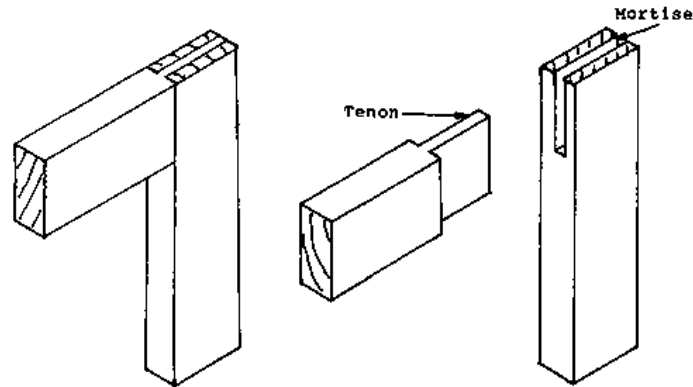
d) Where to use housing joints: - The housing joint is mainly used on construction work.



Figure

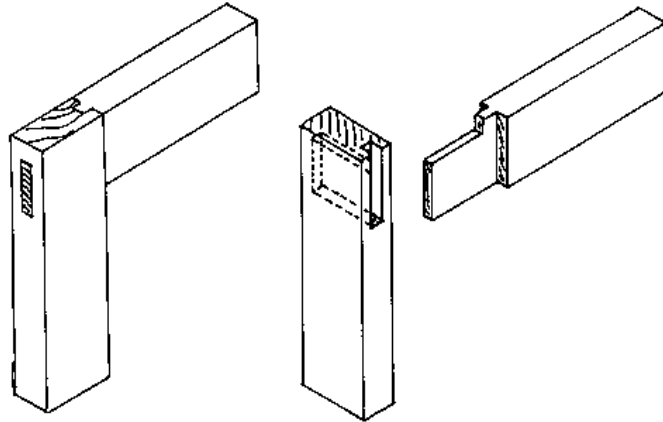
e) Mortise and Tenon joint:

- Open mortise and tenon joint: This is the most common form of connecting members together in framed construction and consists of a parallel sided, thinned projection on one piece (Tenon) fitted into a corresponding slot or cavity in the other piece (Mortise). The two being secured together by glue aided by wedges and/or pins.



Figure

- Haunched mortise and tenon joint: Where a mortise and tenon occurs at the end of a stile it must be reduced in width so that when fitting the door or sash the tenon will not be interfered with when the surplus timber is removed. There should also be sufficient wood left beyond the mortise to withstand the force of the wedges when glueing up. The small stub tenon left when cutting down the tenon is called a "haunch".



Figure

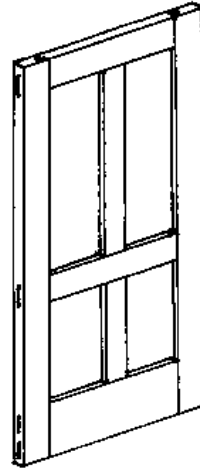
f) Where to use a mortise and tenon joint:

- **An open mortise and tenon joint is commonly used on cupboard doors.**



Figure

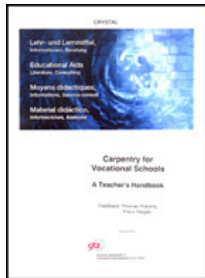
- **A haunched mortise and tenon joint is used for external and internal doors.**



Figure



[Home](#) > [ar](#).[cn](#).[de](#).[en](#).[es](#).[fr](#).[id](#).[it](#).[ph](#).[po](#).[ru](#).[sw](#)




 **Carpentry for Vocational Schools - A Teacher's handbook (GTZ, 252 p.)**

➔  **10. BRACING**

 **(introduction...)**

 **10.1. Structurally**

 **10.2. Wallframe**

 **10.3. Braces**

Carpentry for Vocational Schools - A Teacher's handbook (GTZ, 252 p.)

10. BRACING

TOPIC: 10. BRACING

INTRODUCTION: This topic teaches students the purpose of braces and how braces are fitted correctly.

OBJECTIVES: Students should be able to define the purpose of braces and how braces are fitted correctly to give the wallframe the strength necessary to carry the load of the roof.

METHOD: We prepare four boards, nails and a hammer for this lesson.

For better understanding of the purpose of braces, demonstrate the weakness of a rectangle by nailing the four boards into a rectangle. Let students try to press it from two opposite corners and they will realise that the shape has not much strength.

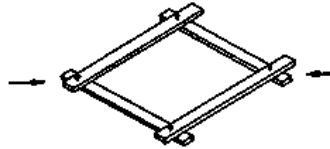
Now nail the boards into a triangular shape and let students try to press it out of shape. They will realise that it is not possible.

When possible show students walls which are already braced to give some idea of how braces are fitted correctly.

NOTE: At the end of this section we prepare a worksheet to reinforce this topic.

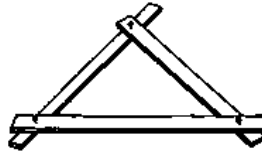
10.1. Structurally

a) Rectangle: - If you press a rectangle from two opposite corners together, you find that the frame is easily distorted and the rectangle is structurally weak.



Figure

b) Triangle: - If you press a triangle from two corners together, you find that the frame does not give. It is rigid. The triangle is structurally strong.



Figure

10.2. Wallframe

a) Rectangle: - The wall frame of a house is a rectangle made of many smaller rectangles and squares and is therefore weak.



Figure

b) Triangle: - To make a wall frame stronger we must include some triangles in the frame. We do this by fixing braces to it.

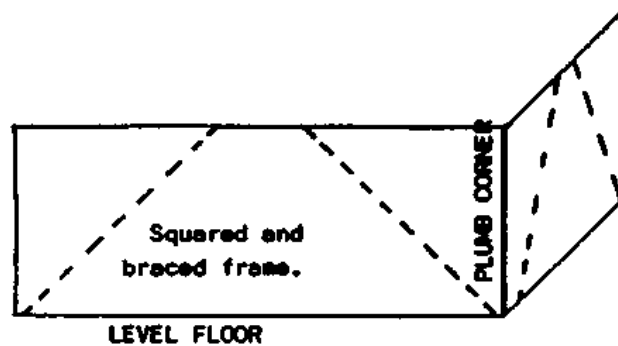


Figure

10.3. Braces

The more braces that are fixed to the wall frame the more rigid it becomes. Braces must go from bottom plate to top plate at as low an angle as possible. Before braces are fixed to the frame you must check that the frame is square. This is best done by measuring the diagonals while the frame is lying horizontal on a flat surface.

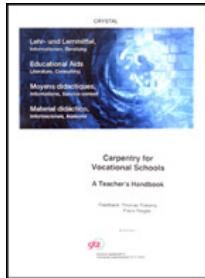
If the frame is squared and braced before it is erected, you can be sure the external corners are plumb.



Figure



[Home](#) > [ar.cn.de.en.es.fr.id.it.ph.po.ru.sw](#)



 **Carpentry for Vocational Schools - A Teacher's handbook (GTZ, 252 p.)**

  **11. WALLFRAME**

 **(introduction...)**

 **11.1 Parts of a wallframe**

 **11.2. Procedure of making a wallframe**

 **11.3. Erecting a wallframes**

Carpentry for Vocational Schools - A Teacher's handbook (GTZ, 252 p.)

11. WALLFRAME

TOPIC: 11. WALLFRAME

INTRODUCTION: This topic teaches students the parts of a wallframe, how a wallframe is made, how a wallframe is erected and joined to other wall-frames.

OBJECTIVES:

11.1. Students should be able to name all the parts of a wallframe.

11.2. Students must be able to describe the procedure of making a wallframe. Students should also be able to make wall frames independently.

11.3. Students should be able to describe the procedure of erecting a wallframe.

METHOD: Beside the theoretical lessons it is advised to demonstrate each step when making a wall-frame.

If it is not possible to do it on a building-project, we have to make a model of a wall-frame in the scale 1:10. We can use the foundation model from the previous lessons too.

11.1. After explaining in the classroom and making a drawing of a wallframe in the trade theory book, show students a prepared model of a simple wallframe and let students name the parts of it.

11.2. After explaining this step on the black board, get two prepared pieces of long timber where we can demonstrate how corner studs, studs for doors and windows and intermediate studs are marked correctly. We do it first and let

students do it afterwards.

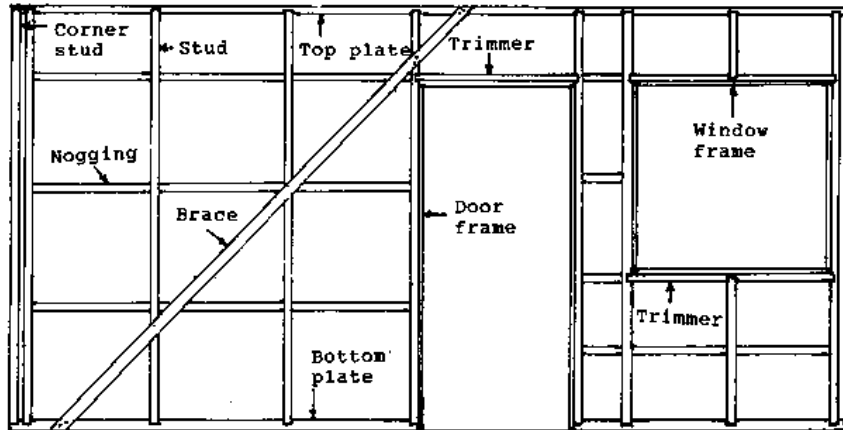
When students are confident with marking the studs on the top and bottom plates, prepare small timbers in the scale of 1:10 to make now a model of a wallframe.

When planing to make a complete model house, it is advised to draw a plan before starting the wallframes.

11.3. Erecting wallframes is difficult to demonstrate on a model house. We only can explain it verbally.

NOTE: At the end of this topic prepare 'again a worksheet with questions about wallframes for the students which they have to fill in in their own time to be assessed later.

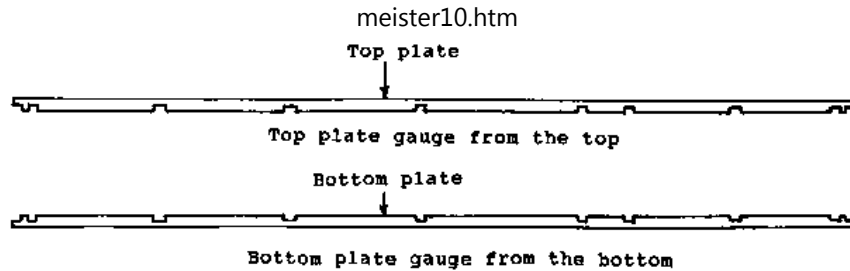
11.1 Parts of a wallframe



Figure

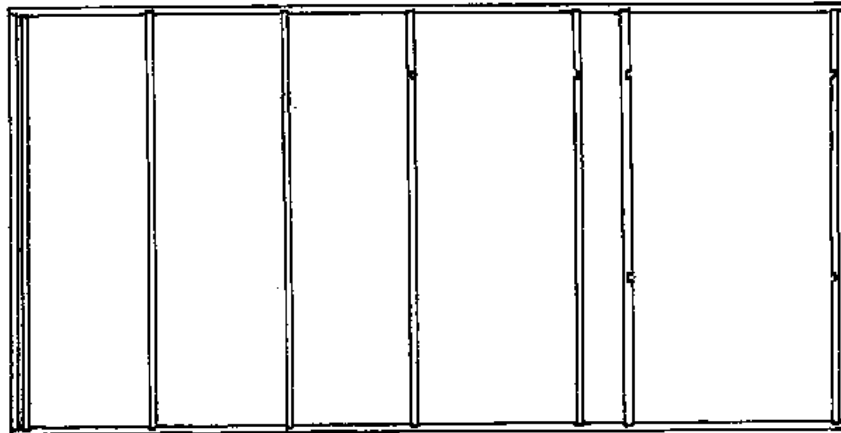
11.2. Procedure of making a wallframe

a) Top and Bottom plate: - To join the studs to the top and bottom plate, we use housing joints. Gauge the housing joints with a marking gauge or combination try square, on the topplate from the top and the bottomplate from the bottom. Using this method, we achieve the correct depth of the housing joints even if the timber is not cut at a uniform size. The depth of the housing joint is 5 mm - 10 mm.



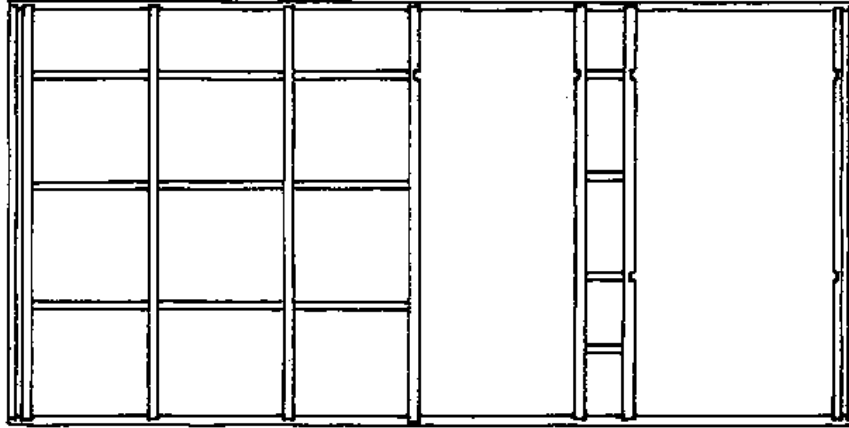
Figure

b) Studs: - Mark cornerstuds, doors and windowstuds first, using the straightest pieces. When completed, mark all the other studs using double studs at the corners. Nails are used to fasten studs to bottom and top plate.



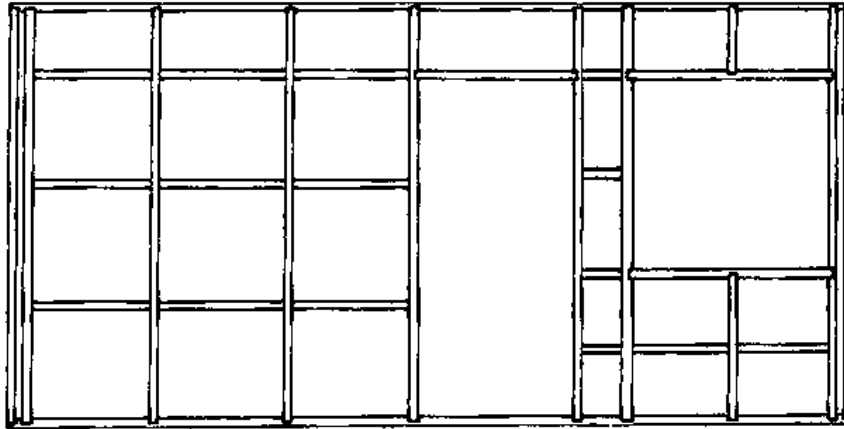
Figure

c) Noggings: - Fit the noggings so that the studs are held straight.



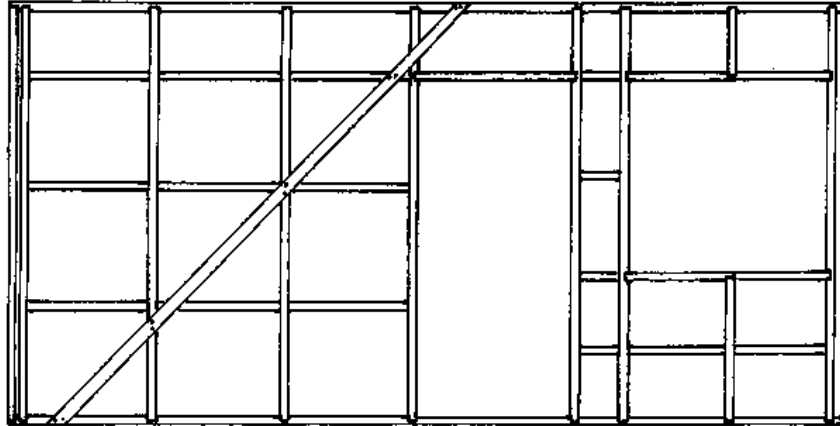
Figure

d) Trimmers: - To join the trimmers to the studs use the housing joint. When fitting the trimmers allow enough space for the door and window frame.



Figure

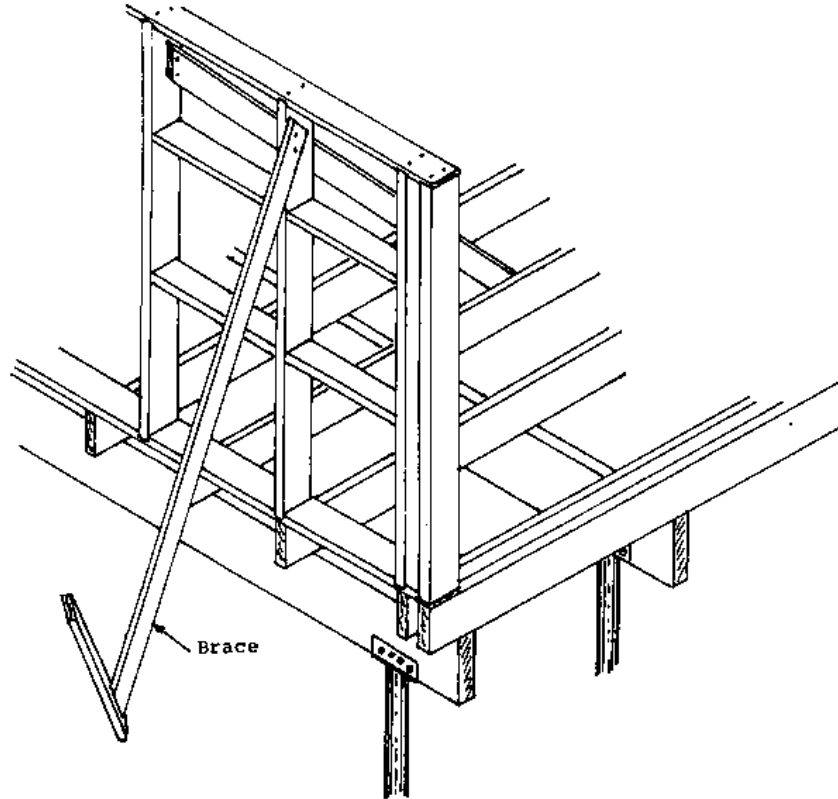
e) Braces: - Before braces are fixed to the frame you must check that the frame is square. This is best done by measuring the diagonals while the frame is lying horizontal on a flat surface. If the frame is squared and braced before it is erected you can be sure that the external corners are plumb.



Figure

11.3. Erecting a wallframes

a) Erecting Wallframes: - When the walls are ready to be erect, they should be firm and strong enough to take the weight of the ceiling and roof construction without losing their shape. Before erecting the wallframes, mark the correct place for fitting them on the floor joists with the aid of a string. Start with the outside frames. Use a spirit level or plumb bob to set them correctly vertical. Fit enough braces to hold them in place. Afterwards fit the inside walls.

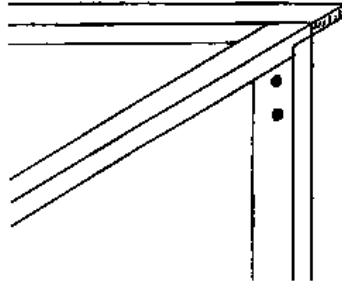


Figure

b) Joining wallframes at the corner:

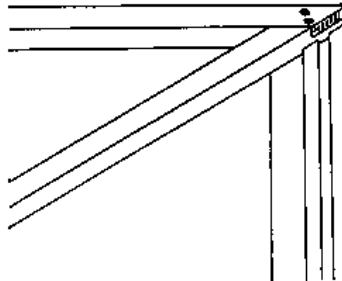
- To join wallframes at the corner we may use the halving joint or the butt joint. In both cases we have to nail the corner.

- Butt joint:



Figure

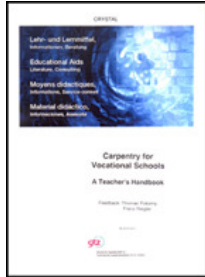
- Halving joint:



Figure



[Home](#) > [ar](#).[cn](#).[de](#).[en](#).[es](#).[fr](#).[id](#).[it](#).[ph](#).[po](#).[ru](#).[sw](#)



Carpentry for Vocational Schools - A Teacher's handbook (GTZ, 252 p.)

12. CEILING

 **(introduction...)**

 **12.1. Ceiling joists**

 **12.2. Purpose of the ceiling joists**

 **12.3. Joining ceiling joists**

 **12.4. Ceiling joists used as part of a roof truss**

 **12.5. Hanger**

 **12.6. Manhole**

 **12.7. Stairway**

Carpentry for Vocational Schools - A Teacher's handbook (GTZ, 252 p.)

12. CEILING

TOPIC: 12. CEILING

INTRODUCTION: This topic teaches students the purpose of ceiling joists, different types of ceiling joists, the way ceiling joists can be joined, hanging of ceiling joists and the correct distance between ceiling joists and how to fit a manhole in the ceiling.

OBJECTIVES:

12.1., 12.2. Students must be able to describe what ceiling joists are and their purpose;

12.3. Students must know the only place where ceiling joists can be joined.

12.4. Students must know that ceiling joists can also serve as floor joists for a second floor or as part of a roof construction.

12.5. Students must be able to describe how ceiling joists are hung correctly so that the ceiling construction is level and strong enough to carry the weight of the plywood.

12.6. Students should be able to define what a manhole is and its purpose.

12.7. Students should be able to describe a stairway and its purpose.

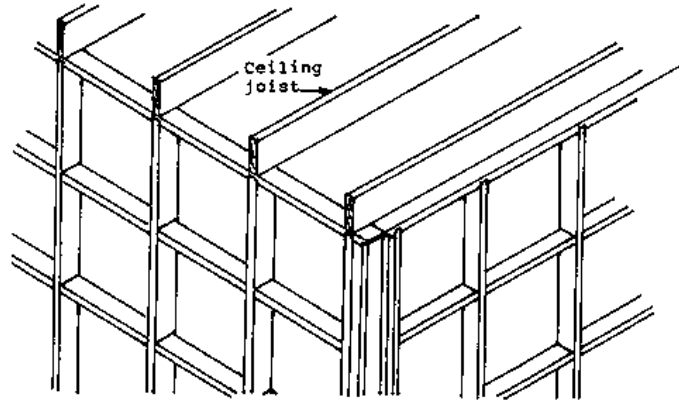
METHOD: First we have all the lessons in class where students take notes from the blackboard and copy down drawings or, if prepared, glue photocopies in their trade theory book.

Where possible demonstrate this topic on a building project. If not, again use the model house where students fix the prepared ceiling joists in the scale 1:10.

NOTE: At the end of this topic prepare a worksheet with questions about ceiling joists and hand it out for students to complete. Collect it later on for correction and assessment.

12.1. Ceiling joists

The pieces of timber placed on top of the wallframe are called the ceiling joist.

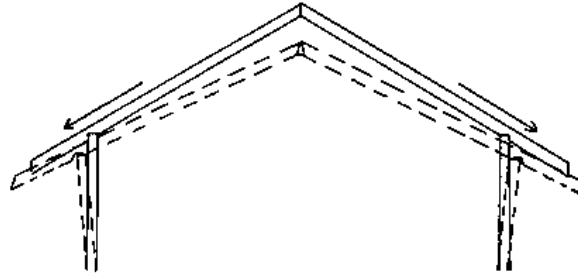


Figure

12.2. Purpose of the ceiling joists

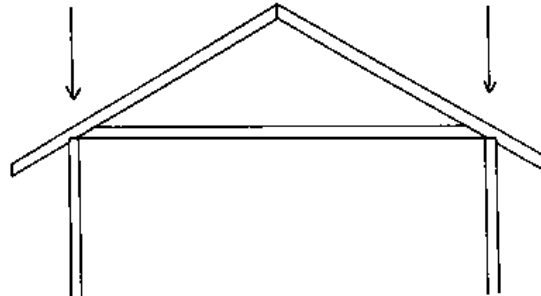
a) Strengthening the house construction:

- If there are no ceiling joists, the weight of the roof will tend to spread the walls.

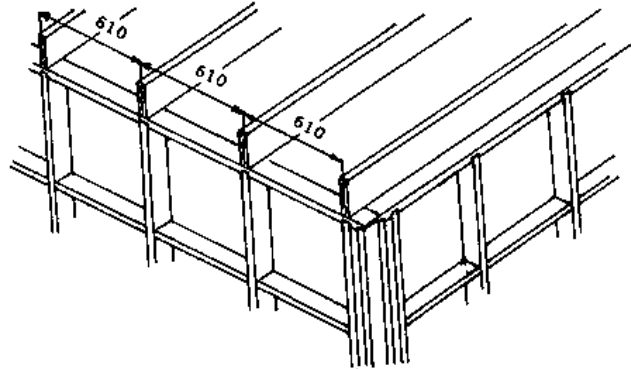
**Figure**

**- Through the ceiling joists exist a triangle construction which is immovable
This means the pressure of the roof is straight downwards.**

Ceiling joists are fixed across the narrow way of the house. Every second or third ceiling joist has to be placed near a rafter and connected to that rafter, so the ceiling joists act as ties to the bases of the rafters.

**Figure**

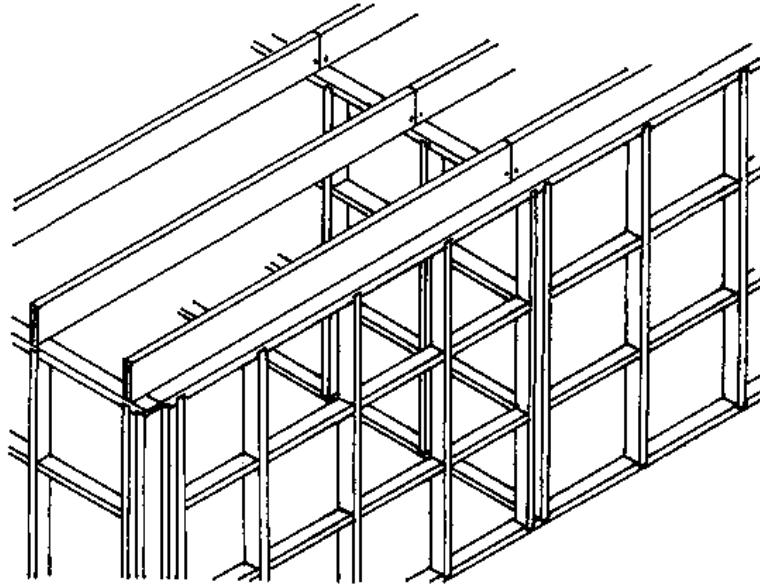
b) carrying the ceiling material: - Plywood, masonite etc. is nailed onto the ceiling joists. Depending on the ceiling material being used, the distance between each ceiling joist will vary from 500 mm - 700 mm. When plywood is used, the distance from the centre of one ceiling joist to the centre of the next ceiling joist is 610 mm.



Figure

12.3. Joining ceiling joists

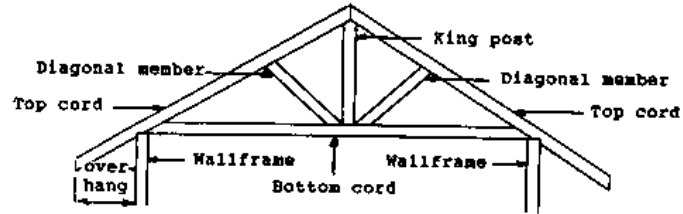
Ceiling joists can only be joined on wallframes. The butt joint is used in this case. You have to nail both pieces.



Figure

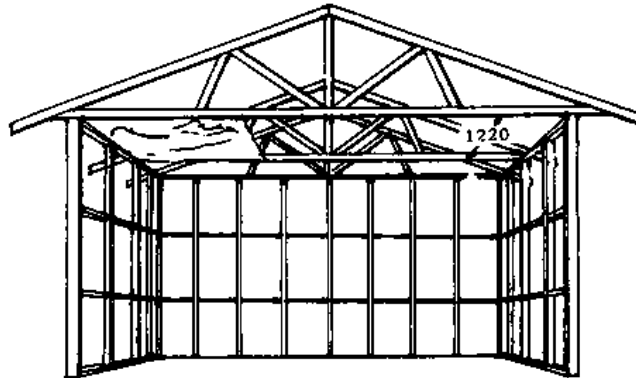
12.4. Ceiling joists used as part of a roof truss

a) Roof truss: - A truss consists of one bottomcord, two topcords, one king post and few diagonal truss members. The topcords are acting like rafters and the bottomcord acts like a ceiling joist.



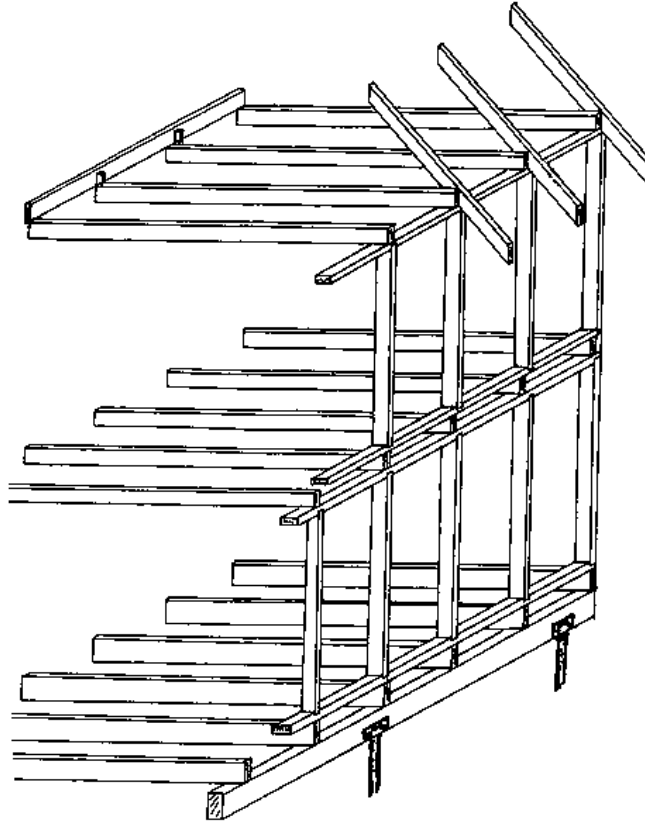
Figure

b) Bottomcord: - When roof trusses are used, the bottom-cord acts like a ceiling joist. In such cases the roof trusses have to be fixed, depending on the ceiling material, at the correct distance (Plywood: centre to centre 610 mm or 1220 mm). Where roof trusses are set 1220 mm apart, a separate construction has to be made to support the plywood in the centre between the two trusses and at the cross joints of the plywood.



Figure

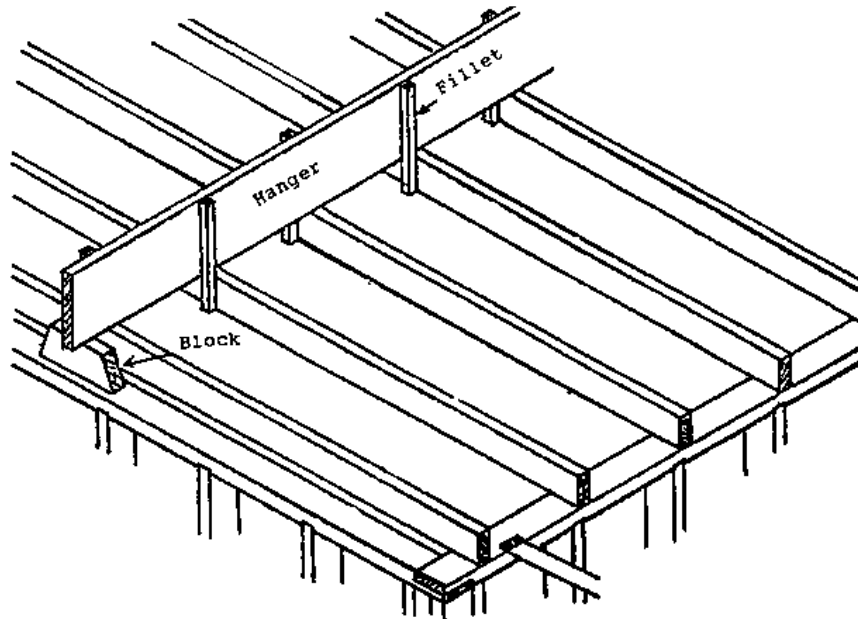
c) Two storey house: - In buildings with two stories, the ceiling joists of the ground floor are the floor joists of the first storey.



Figure

12.5. Hanger

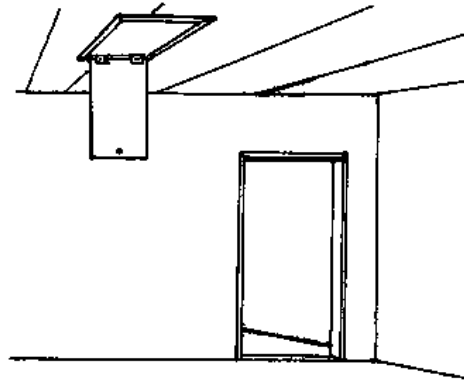
When ceiling joists have to cover longer distances, it may be necessary to give them extra support. This is done with hangers. Hangers should be placed from one side right through to the other without any joints. The joining between ceiling joists and hangers is done with a fillet. Hangers are placed above joists at intervals of 1500 mm to 2000 mm.



Figure

12.6. Manhole

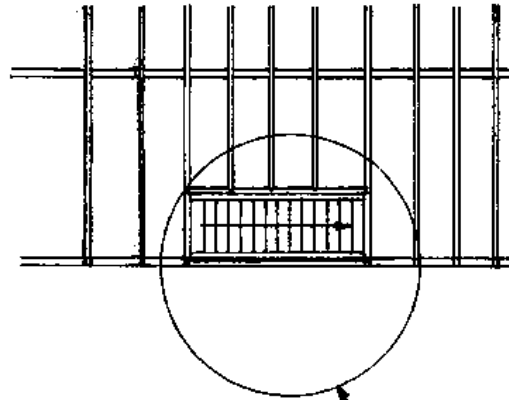
The manhole is used as an entrance into the attic. In many cases the attic is used as storage space although it is usual for the electrical wiring and water pipes to run across the attic floor for connection to the individual rooms underneath. This makes them easily accessible for work and repair at any time.



Figure

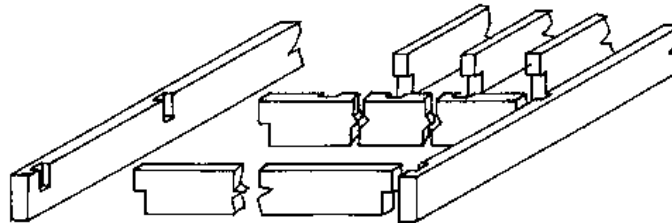
12.7. Stairway

When a stairway is required from the ground floor to the first floor we have to cut out one or more ceiling joists to allow space for the stair cases. To hold the remaining ceiling joists in the correct places, we use "trimmers". Trimmers are placed from the first ceiling joist on either side of the space for the stairway. To join trimmers to the ceiling joists, we use a halving joint.



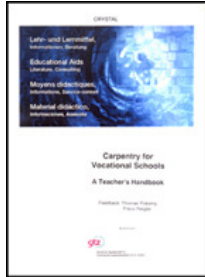
Detail on next image

Figure



Figure





Carpentry for Vocational Schools - A Teacher's handbook (GTZ, 252 p.)

➔ **13. ROOFING**

 **(introduction...)**

 **13.1. Different roof shapes**

 **13.2. Technical terms of a roof**

 **13.3. Rafter and ridge roof**

 **13.4. Roof truss**

 **13.5. Diagonal roof bracing**

 **13.6. Roofing iron**

 **13.7. Laying of roofing iron**

 **13.8. Finishing a roof**

Carpentry for Vocational Schools - A Teacher's handbook (GTZ, 252 p.)

13. ROOFING

TOPIC: 13. ROOFING

INTRODUCTION: This topic teaches students the different roof shapes; the names of the parts of a roof; how a roof truss is calculated, made, erected and braced; the proper distance for purlins; roofing iron and different types of roofing fasteners; laying of roofing iron, ridge cap and finishing roof.

This topic is very comprehensive. therefore select carefully the chapters you are able to fit into the yearly programme at the school.

OBJECTIVES:

13.1. Students should be able to distinguish between the different roof shapes and their characteristics.

13.2. Students should be able to name all the parts of a roof.

13.3. To know when a rafter or ridge roof is needed, their technical terms and how they are made.

13.4. Students should know the names of the parts of a roof truss, how the height and the number of diagonal members are calculated, how a truss is made and assembled and how the trusses are erected.

13.5. To know the purpose of braces and how they are fixed correctly.

13.6. Students must know the size of the roofing iron and be able to space the purlin correctly.

13.7. Students must be able to describe how roofing iron is laid and fastened correctly.

13.8. Students should be able to finish a roof by laying the ridge cap, fixing fascia and barge board and hanging the gutter.

METHOD This topic is taught in the classroom first. We prepare photocopies of the drawings of this topic and students glue it in their trade theory book. We also prepare some roof models for better understanding.

13.1. If there are buildings with different

13.2. roof shapes near the school, show them to the students and let them name their parts.

13.3. Prepare the timber for a model of a rafter roof in the scale 1:10 and construct it with the students.

13.4. If we cannot demonstrate the process of making a roof truss on a building project, we can again use our model house and prepare timber for a roof truss In the scale 1:10. Explain how to do this work step by step.

13.5. Prepare some small strips of flat iron and allow students brace the roof of the model house correctly.

13.6. Prepare the timber for the purlins in the scale 1:10 and students place the purlins on top of the trusses and nail them. Show students how purlins are straightened properly.

13.7. Prepare some pieces of flat iron which are to be used as roofing iron for the model house and let students follow the procedure they have learned in the theory lesson.

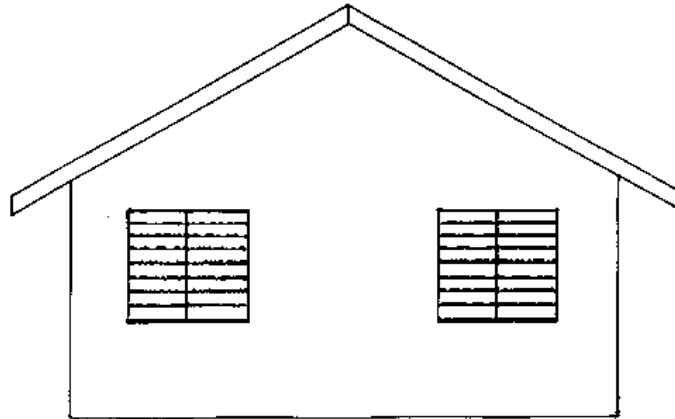
13.8. Prepare small flat irons to use as ridge cap for the model house and timber in the scale of 1:10 for fascia and barge board. Students can complete the roof now.

NOTE: Because of the size of this section it is advisable that at least two worksheets are prepared for students, to complete in their own time.

The main purpose of any roof construction is to carry the weight of the covering material which prevents rainwater from entering the building and protects the inhabitants from sun and wind.

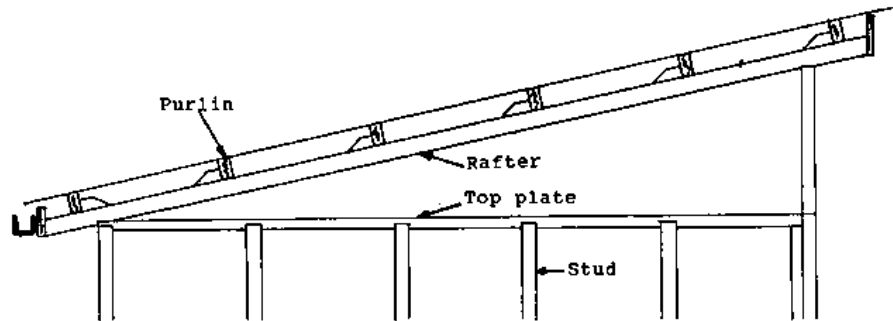
13.1. Different roof shapes

a) Gable roof: - The ordinary roof, which has two sloping surfaces extending from the eaves to a central ridge, and which forms a triangular vertical wall at each end above the wall plates. These triangular shapes are known as "gable ends", hence the name gable roof. The gable roof is most commonly used for small houses because of its simplicity of construction and low cost. This type of roof is often used as the basis of, or in combination with, other types of roofs.



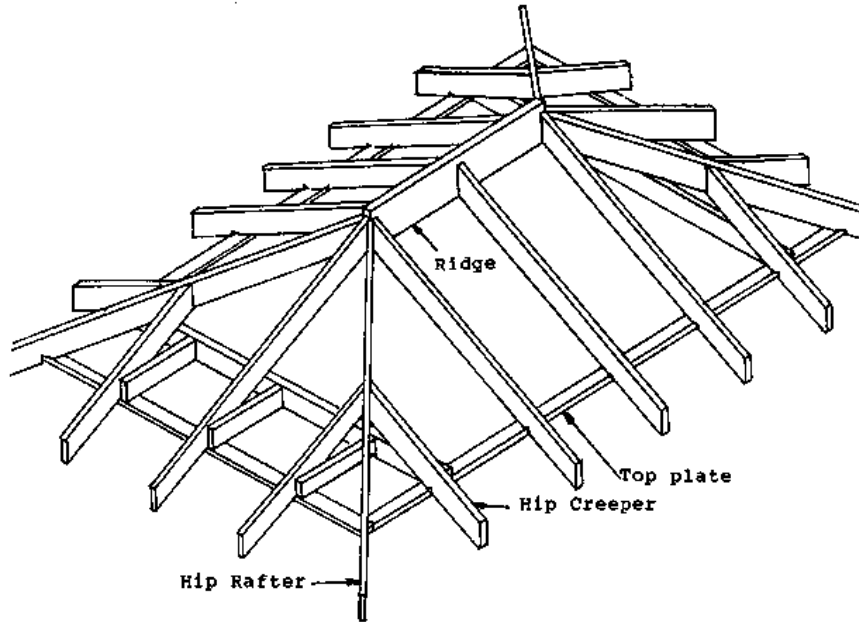
Figure

b) Lean-to or Skillion roof - The lean-to roof is simply a galved gable roof. It is often used in construction for economical reasons (no ridge capping, only one gutter). To pitch the roof at the right angle and to support the rafters, one of the two side walls must be built higher. Ceiling joists are as in the gable roof. When the span is more than four metres, purlins and struts must be fitted.



Figure

c) Hipped roof: - The hip roof has four sides, all of which slope upward towards the centre of the building. The external angle where two adjacent sloping sides meet is called the hip, and the inclined member at this junction is the hip rafter. The hipped roof is more expensive to build as it requires more skilled labour because of the difficult construction. On the other hand, if the complete job is done well, the roof should support itself.



Figure

13.2. Technical terms of a roof

a) Barge board: - The inclined timbers on the gable ends which are fixed to the purlins and cover the ends of the roof timbers.

b) Ceiling joists - Timber across a room to carry the plywood ceiling.

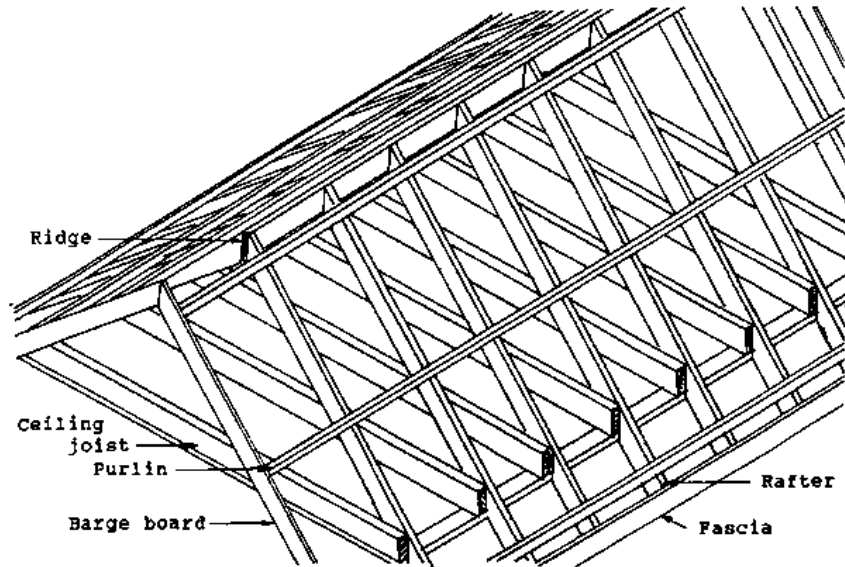
c) Fascia: - The upright board fixed to the feed of the rafters to carry the spouting.

Any wide board fixed on edge.

d) Purlin or Batten - The horizontal member supporting the rafters in a roof which in turns is supported off the walls by struts.

e) Rafters: - The inclined members of a roof between the plate and the ridge which supports the roof covering.

f) Ridge: - The top horizontal member in a roof carrying the rafters.



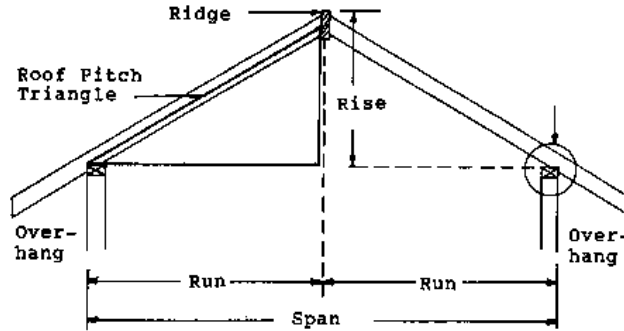
Figure

13.3. Rafter and ridge roof

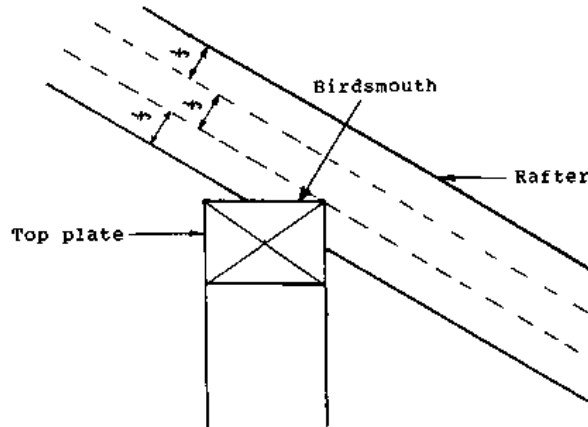
The rafter and ridge roof is used when the span is short or where high ceilings are desired or where rooms have been included in the design of the roof.

a) Technical terms:

- The rise: The rise is the high of the roof.**
- The span: The span is the width of the roof at the base of the roof pitch triangle.**
- The run: The run is half the span.**
- The overhang: The overhang is the distance between the outside wall and the end of the roof, which is parallel to the wall.**
- The roof pitch triangle: The roof pitch triangle is the slope of the roof and is expressed in degrees.**
- The birdsmouth: An angle cut on the edge of a piece of timber so that it sits on the angle of a cross piece. Used at the foot of a rafter, where it sits on the top plate.**



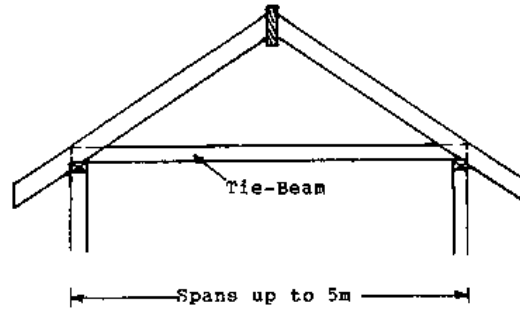
Figure



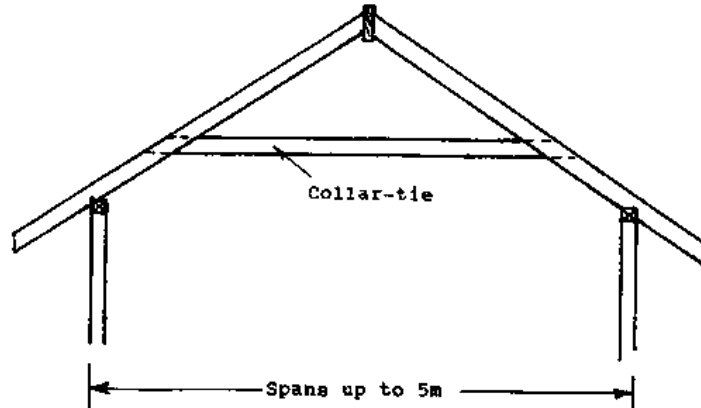
Figure

b) Strengthening the rafter and ridge roof: - If the span of the roof is up to 5 m, it has

to be strenghted. It is done with a COLLAR-TIE or TIE-BEAM.



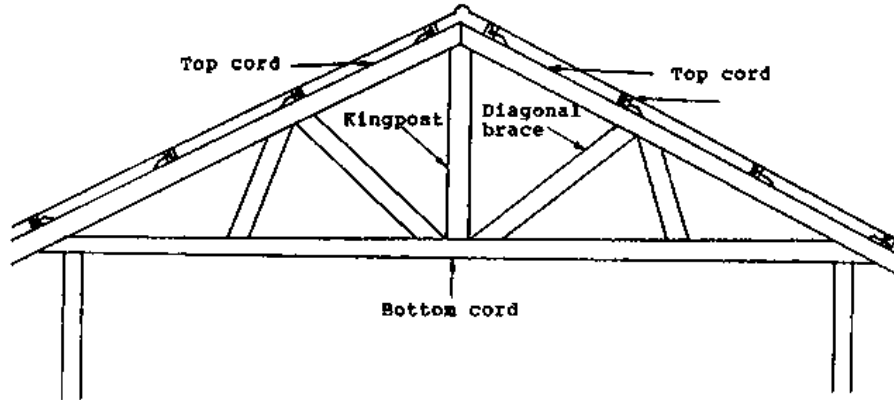
Figure



Figure

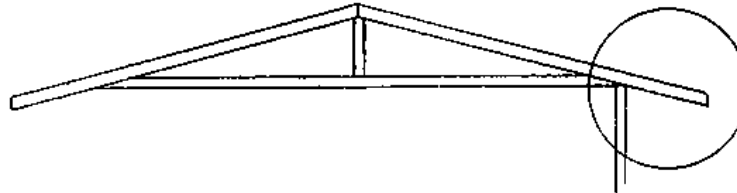
13.4. Roof truss

Where very large spans are required or where low ceilings are designed it is normal to use trusses which are also easier to erect. The roof trusses are made up by a series of triangles. At the bottom cord allow a camber of 12 mm. The camber allows for settlement of the truss when loaded. Trusses are placed at about 3000 mm intervals.

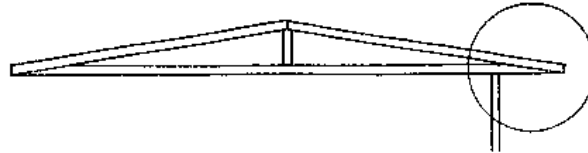


Figure

a) Different truss types according to the overhangs

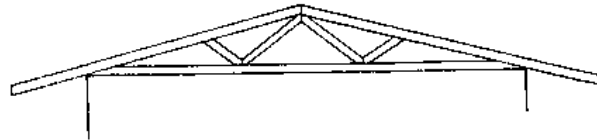


Sloped overhang:

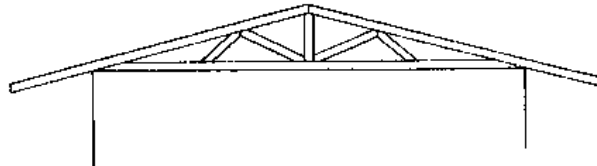


Straight overhang;

b) Different Truss types according to the shape:



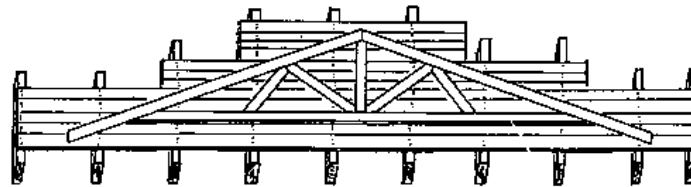
Standard Truss



Kingpost Truss:

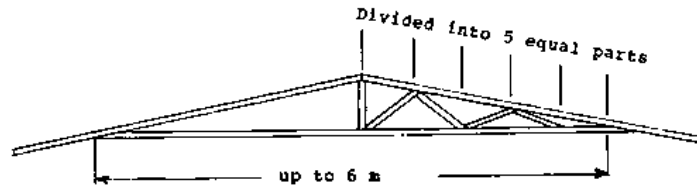
c) Procedure for making a truss:

To make the trusses it is easier to draw a pattern of a truss on a straight surface like a concrete slab or above floor joists or a layer of boards. So you make sure each truss get the same size and shape. Nail all the joints with nail plates, turn the truss and drive in the nail plates on the other side.

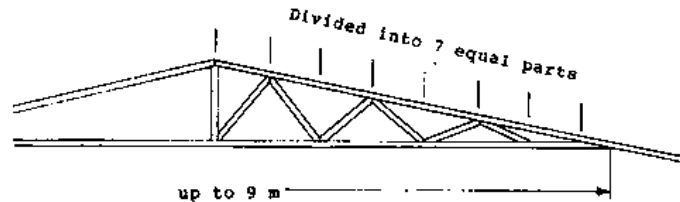


Figure

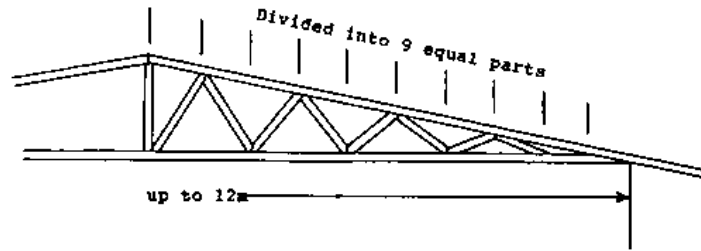
d) How to set the braces: - Kingpost Truss,



Span up to 6 m.

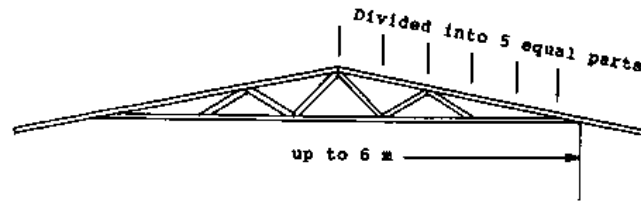


Span up to 9 m.

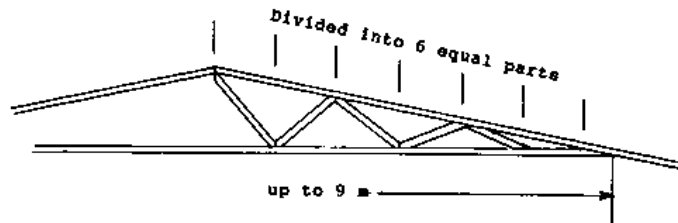


Span up to 12 m.

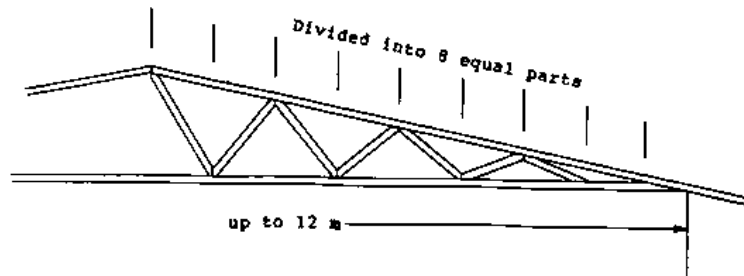
e) How to set the braces: - Standard truss,



Span up to 6 m.



Span up to 9 m.

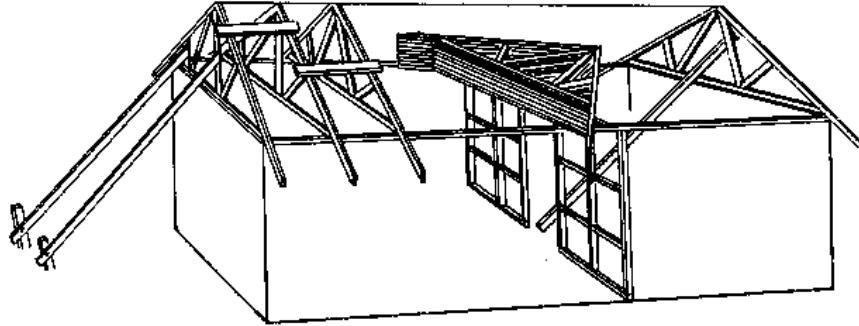


Span up to 12 m.

f) Erecting roof trusses:

Mark the truss position on the top of the wall plates. Erect gable-end truss, ensuring trusses are flush and plumb with the wall plate. If it is necessary tack the roof trusses into position. Braces are fixed to the ground outside the building. If these braces are too long, they will prove ineffective. In this case, attach braces internally to the internal walls. Stretch a string line to the apex of one gable truss to the apex of the other. All intermediate trusses are positioned exactly to the string line. Position the second truss temporarily, and brace back to the first truss. Continue erecting trusses in this way. Secure trusses to the top plate with ripple grips, straps or specified anchorage hardware. Do not leave roof trusses overnight without anchorage. After erecting all trusses you start to nail the battens, making sure the truss is exactly plumb and straight. If that procedure is finished attach permanent diagonal braces.

NOTE: Before erecting roof trusses, you have to straighten out the top plates. Brace it well, especially at that part, where a roof truss is placed.

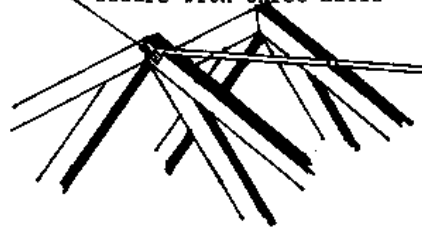
**Figure**

13.5. Diagonal roof bracing

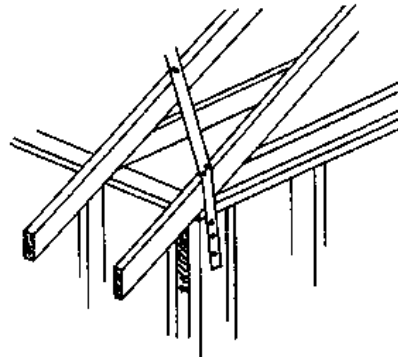
For bracing the roof a flat metal brace is used. The roof has to be braced diagonally on both sloped sides. The braces are fixed to the purlins or battens. It is of advantage to secure the brace at every crossing with two nails. The top end of the brace is fixed to the rafter.

**Figure**

Bend brace over at ends and
secure with three nails



Figure

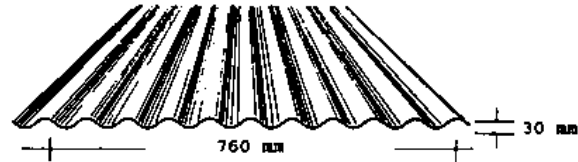


Figure

13.6. Roofing iron

Roofing iron is corrugated for many reasons. It is stronger and more able to withstand load than flat sheets. The corrugations also give definite ware channels and serve to gauge the side lap of the sheets, and when nailed through the crown lines of

the roof are more waterproof.

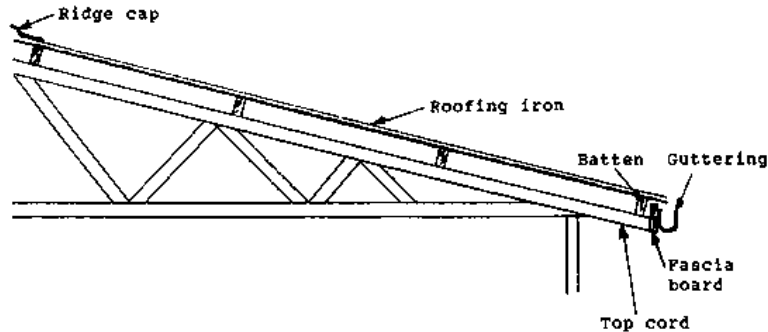


Figure

a) Space the Purlin or Batten: - For corrugated roofing iron use battens with a size of 75 mm x 38 mm minimum. Place one batten near the ridge so that the ridging can be nailed to it and the bottom batten so that its top edge is in line with the plumb-cut of the rafter feet. The remainder are spaced in between.

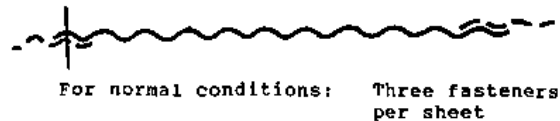
The battens should be set at a distance of 1200 mm to 1400 mm. The distance should not exceed 1400 mm.

NOTE: If there are two or more rows of roofing irons, the overlap should be approximately 300 mm.

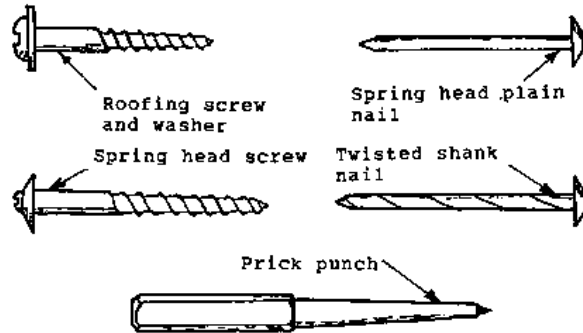


Figure

b) Fastening corrugated roofing iron: - The most effective way of fastening corrugated iron is by means of roofing screws and washers. Cheaper fixing methods are the spring-head plain nail, the twisted shank nail or the springhead screw. Holes should first be made with a brick punch which must be kept sharp to prevent denting of the corrugations .



Figure



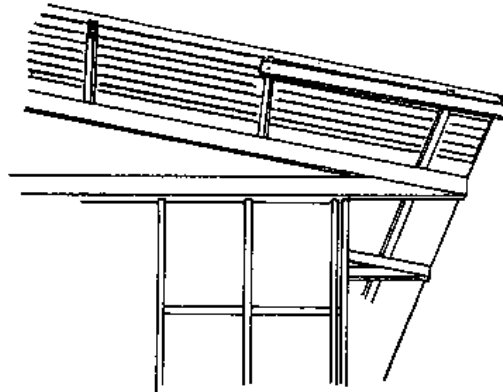
Figure

13.7. Laying of roofing iron

A timber is nailed across the endgrain of the lowest batten. From the outside top edge of that batten, where you have nailed the timber across, you have to measure down 70 mm. It should not be more or less than 70 mm. If it is less, water could pour down between the gutter and fascia board. On the other hand, if it is more than 70 mm, the water could overshoot the gutter. Make a mark on the timber which you nailed across that batten and drive a nail in. At the other end of the roof you repeat this procedure and stretch a string between the two nails. Make sure the string is tight so the roofing iron will not touch it.

Now you have a straight line and can start laying the sheets, the lower edge of the sheet has to be in line with the string. One worker has to stand directly below the string and direct the worker on the roof to move the roofing exact position above the string.

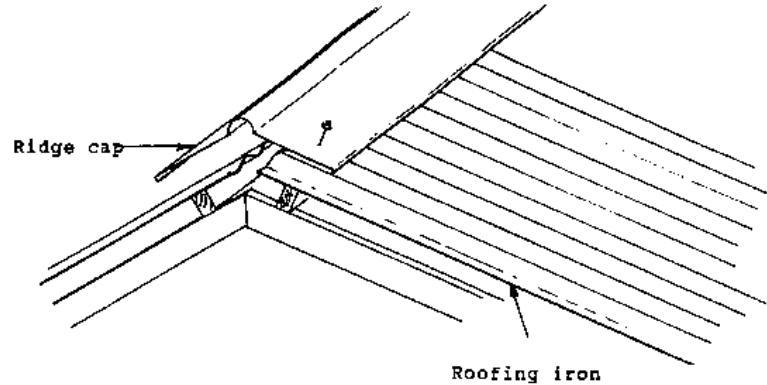
NOTE: The battens have to be exactly straight.



Figure

13.8. Finishing a roof

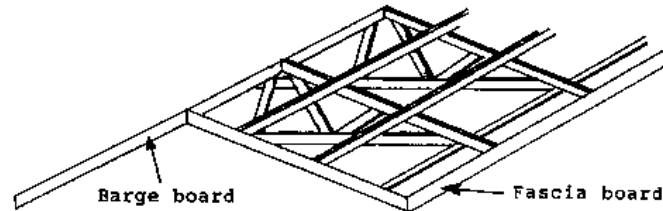
a) Ridging or ridge cap: - The ridging or ridge cap covers the ridge at the top of the roof NOTE: the roofing iron and the ridge cap are nailed together to the batten.



Figure

b) Sisalation paper: - It is a aluminium coated paper which is used to stop the heat and cold from entering the house.

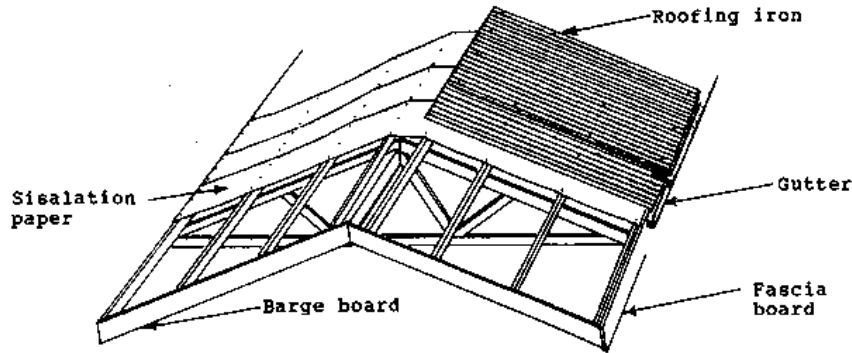
c) Fascia board: - The fascia board is the upright board fixed to the end of the rafters to carry the gutter.



Figure

d) Barge board: - The inclined timbers on the gable-ends which are fixed to the rafters and cover the ends of the roof timbers.

e) Gutter: - The gutter is a galvanised iron spouting and is fixed by means of brackets to the end of the rafters or to the fascia board.



Figure



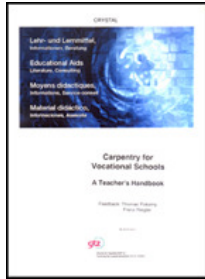
[Home](#) > [ar.cn.de.en.es.fr.id.it.ph.po.ru.sw](#)




 **Carpentry for Vocational Schools - A Teacher's handbook (GTZ, 252 p.)**

➔  **14. WINDOWS**

 **(introduction...)**

 **14.1. Parts of a window frame**



-  **14.2. Calculating of a window opening**
-  **14.3. Joining a window frame**
-  **14.4. Fixing a window frame**

Carpentry for Vocational Schools - A Teacher's handbook (GTZ, 252 p.)

14. WINDOWS

TOPIC: 14. WINDOWS

INTRODUCTION: This section teaches students the names of the parts of a window frame, calculation of an opening for a window frame and how window frames are made, assembled and fitted into the wallframe.

OBJECTIVES:

14.1. Students must be able to name the parts of a window frame and its timber sizes.

14.2. Students should be able to calculate the opening for a window frame in a wall-frame.

14.3. To know how to make a window frame with the correct joints and fitting the security bars.

14.4. To be able to fit a window frame into a wall frame and finish with painting, nailing flywire and architraves around the window.

METHOD: The most difficult part in this section is undoubtedly the calculation of the opening for a window frame in a wallframe.

Therefore a lot of time is needed for practising this calculation.

14.1. Prepare a window frame (a window from the classroom can be used) with all the parts and display it in the classroom for better understanding.

14.2. Prepare photocopies of the tables with the measurements for the openings. Explain to students with aid of blackboard and the window frame the process of calculating the opening.

14.3., 14.4. These two chapters can only be demonstrated on-the-job, but if there is no opportunity to show it on a building project, classroom explanation will be sufficient.

NOTE: It is very important in this section to set many exercises on calculating the opening, because that is the most important step in producing a window of the correct size.

Windows give the house a certain outlook and therefore it is very important to choose a good number of windows of sufficient size to prevent a wall from looking boring. In coastal areas you will make the windows very large, almost down to the floor, to provide good circulation of air in order to keep the room cool.

For highlands, because of the colder climate, windows are made smaller.

When locating the windows and considering their size you have to consider the furniture, toilet and showers, to avoid having a window where a cupboard will eventually be.

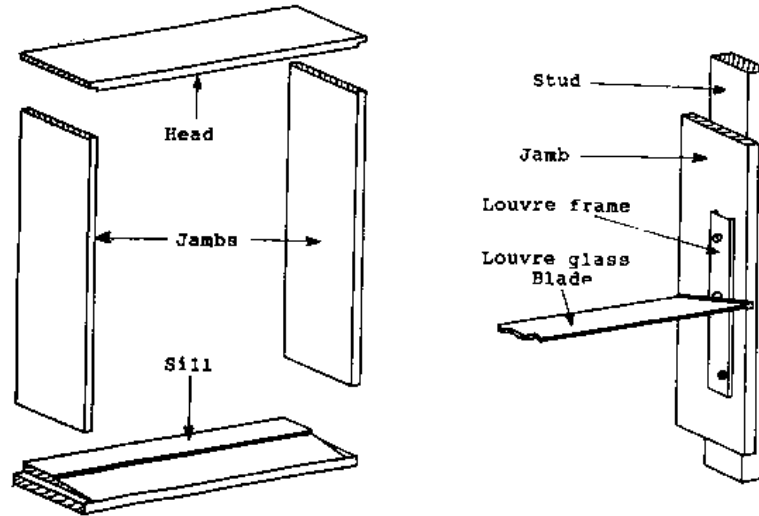
Windows for bathrooms and toilets usually have only 4 blades.

Windows for bedrooms and kitchen have from 7 to 10 blades.

Windows for sitting rooms have up to 14 blades.

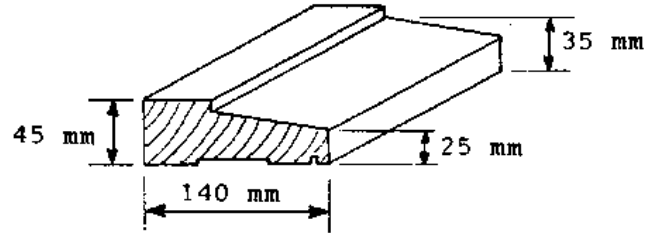
The glass louvres can be opened to any angle by simply moving a lever and there is a locking device for use when the louvres are closed.

14.1. Parts of a window frame



Figure

Windowsill: - The windowsill is the lowest part of the window frame. It is specially designed to provide a stop for the lowest louvre glass and to let the rainwater run off. On the bottom of the sill is a waterdrop off groove. Windowsills are available from building material stores and timber-selling companies.



Figure

Jambs: - The jambs are the side parts of the window frame on which the louvre frames are screwed. The thickness of the jambs can be from 22 mm up to 30 mm. The width is the same as the windowsill.

Head: - This is the upper part of the window frame and is the same size as the jambs.

14.2. Calculating of a window opening

The opening you have to leave for a window in a wall frame depends on the number of louvre blades, the louvre frame, the thickness of the window frame-timber and the number of windows joined together (single, double-window etc.) as well as the length of the louvre glass.

a) CALCULATING THE WIDTH OF AN OPENING:

- For the width of an opening (between two studs) you have to know the thickness of the jambs, the space for the louvre frame, the length of the louvre glass and the number of windows.

The following table will enable you to find the correct measurements for the opening of the WIDTH of a window frame in the wall frame by a timber thickness of the jambs of 22 mm.

NOTE: Do not apply it to timber of other thicknesses!

Louvre glasses are available in following length:

12" = 305 mm

20" = 507 mm

22" = 558 mm

24" = 610 mm

27" = 685 mm

30" = 769 mm

32" = 812 mm

36" = 914 mm

1 window

GLASS OPENING

12" 389 mm

20" 591 mm

22" 642 mm

24" 694 mm

27" 770 mm

30" 846 mm

32" 896 mm

36" 1000 mm

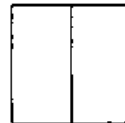


Figure

2 windows

GLASS OPENING

12"	756 mm
20"	1160 mm
22"	1262 mm
24"	1366 mm
27"	1516 mm
30"	1670 mm
32"	1770 mm
36"	1974 mm



Figure

3 windows

GLASS OPENING

12"	1123 mm
20"	1730 mm
22"	1882 mm
24"	2038 mm
27"	2263 mm
30"	2494 mm
32"	2644 mm
36"	2950 mm



Figure

4 windows

GLASS OPENING

12"	1490 mm
20"	2300 mm
22"	2502 mm
24"	2710 mm
27"	3010 mm
30"	3320 mm
32"	3520 mm
36"	3926 mm

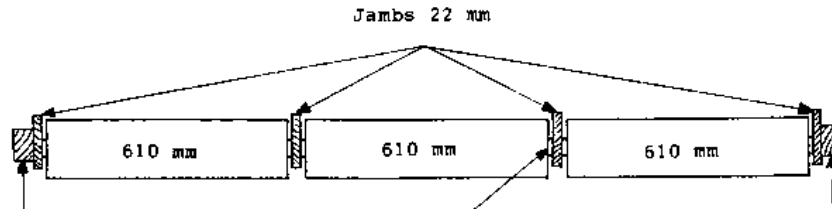
**Figure**

E.g.: We need an opening for 3 windows.

Length of louvre blades = 24" - 610 mm

Timber thickness of jambs - 22 mm

Space for one louvre frame - 20 mm

**Figure**

4 Jambs	ea. 22 mm	= 88 mm
6 Louvre frames	ea. 20 mm	= 120 mm
3 Louvre glasses	ea. 610 mm	= 1830 mm

Total width of window opening = 2038 mm

Now you can compare the result with the table, and you will find exactly the same

measurement!**b) CALCULATING THE HEIGHT OF AN OPENING:**

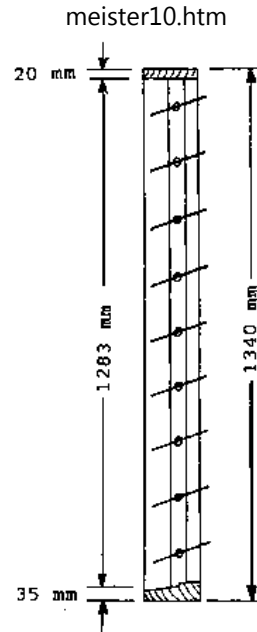
- For the height of an opening (between the trimmers), you have to know the number of blades, the thickness of the head timber and the windowsill.

The following table will enable you to find the correct measurement for the height for a window in a wall frame for a timber thickness of the head of 22 mm and the sill of 35 mm.

Louvre frame with:

3 Blades	502 mm
4 Blades	642 mm
5 Blades	780 mm
6 Blades	920 mm
7 Blades	1060 mm
8 Blades	1200 mm
9 Blades	1340 mm
10 Blades	1480 mm

E.g.: We need an opening for a window with 9 blades in the louvre frame.

**Figure**

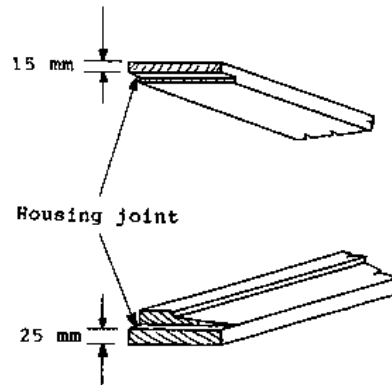
Window head	22 mm
Windowsill	35 mm
Louvre frame 9 B1.	1238 mm

Total height of open 1340 mm

Now you can compare the result with the table, and you will find exactly the same

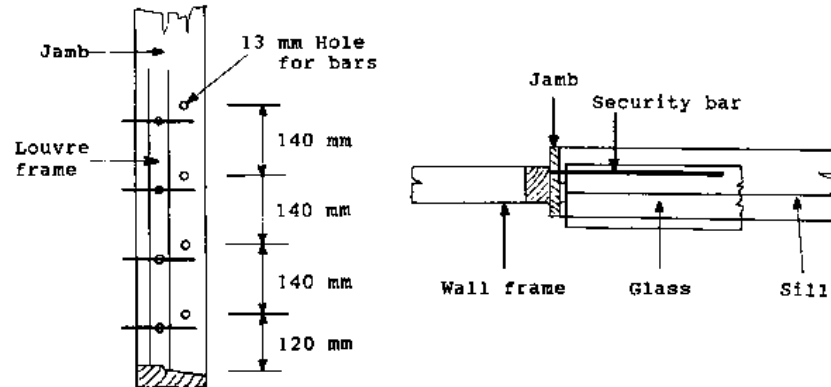
measurement !**14.3. Joining a window frame**

The window frame is joined with housing joints. Sand all surfaces with beltsander before assembling. Then the members of the window frame are glued and nailed together. After joining let the frame rest for some hours to enable the glue to dry.

**Figure**

The next task is to paint the frames with undercoat. When dry, the frame is provided with "Security bars". For locating the position of the 12 mm security bars, a louvre frame is fixed provisionally and the lever is put in open position. Now it is easy to see where to drill the holes to fit the bars.

Firstly, the lowest bar is located approximately 12 cm above the windowsill. Then measure 14 cm from centre to centre for the next holes.



Figure

It is important that the holes are not outside the wall frame after fixing it into the wall to avoid the possibility of pulling the bars out from the window frame.

Drill 13 mm holes for the bars to make sure the bars slide in easily. Paint bars before assembly.

Window frames can be also secured with security wire mesh. This wire mesh is usually simply nailed on the outside of the frame with staples.

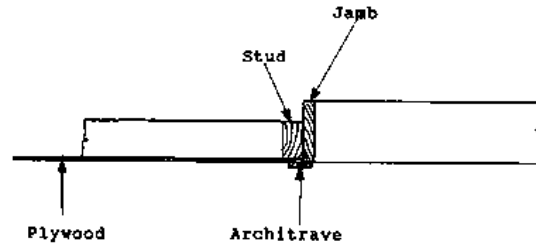
If carpentry machines are available it is advisable to cut a rebate on the frame so that the wire mesh is flush with the outside of the window frame.

14.4. Fixing a window frame

a) Setting in a wall frame:

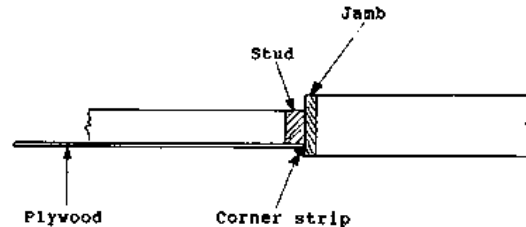
When the window frame is completed, it can be placed in the wall frame opening. There are different ways a window can be fixed in a wall frame.

- The window frame is level with the inside wall.



Figure

- The window frame comes out on the inside wall.



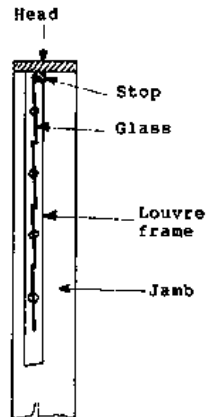
Figure

b) Finishing a window frame: - Punch all nails beneath the surface and fill all holes with a waterproof putty. When dry, sand it and put a second undercoat. Then sand the whole frame again with a fine grit paper and apply the final coat of high, gloss paint.

Also paint the security bars a second time. When dry, the louvre frames are screwed into the frame. For this the bottom of the louvre frame is cut out in order to fit into the rebate on the sill. A stop is also needed on the head when the louvres are in the closed position.

Use 1" roundhead screws for screwing the louvre frames to the jambs.

If necessary, a mosquito screen can be nailed on the outside of the frame and covered with 10 mm cover strips.



Figure



[Home](#) > [ar](#) [cn](#) [de](#) [en](#) [es](#) [fr](#) [id](#) [it](#) [ph](#) [po](#) [ru](#) [sw](#)



 **Carpentry for Vocational Schools - A Teacher's handbook (GTZ, 252 p.)**

➔  **15. OUTSIDE CLADDING**

 **(introduction...)**

 **15.1. Timber weather boards**

 **15.2. Fibre cement boards**

 **15.3. "V" crimp iron**

Carpentry for Vocational Schools - A Teacher's handbook (GTZ, 252 p.)

15. OUTSIDE CLADDING

TOPIC: 15. OUTSIDE CLADDING

INTRODUCTION: This topic teaches students the different types of weather boards and other materials walls can be covered with.

OBJECTIVES:

15.1. Students should be able to state use and characteristics of weather boards. They also should know how weather boards are nailed and joined correctly.

15.2. Students should be able to describe what fibre cement boards are and how they are joined and nailed to the wall.

15.3. Students should be able to define what "V" crimp iron is and how it is joined and nailed to the walls.

METHOD: Prepare samples of different types of weather boards, fibre cement boards and joints, and V - crimp iron and display it in the classroom.

Explain the advantages and disadvantages of each type of wall cladding in the classroom and if there are houses with different types of cladding near the school they can be inspected for better understanding.

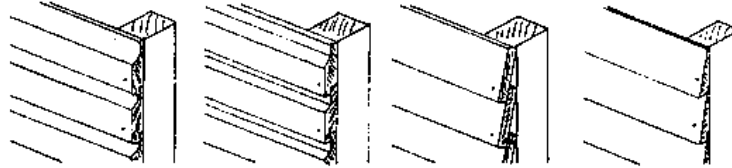
NOTE: At the end of this topic prepare again a worksheet for the students to complete as their homework. Worksheets are collected later, corrected and assessed.

There are several types of material used for cladding the exterior walls of timber framed buildings. The most common types in P.N.G. are timber weatherboards, fibrecement boards or "V" crimp metal sheets. The main purpose of the outside cladding is to protect the timber framed buildings from rain and wind.

15.1. Timber weather boards

Solid timber, in the form of weatherboards, is a widely used type of cladding in P.N.G. Usually the boards are moulded to overlap and look attractive. Normally soft textured timbers are used to reduce the wear on cutters during the moulding process. The use of naturally resistant or pressure treated timber is essential.

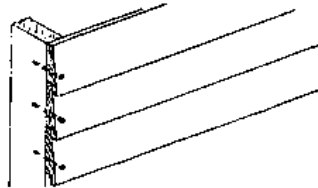
a) There are different profiles of weatherboards:



Figure

b) Fixing the boards:

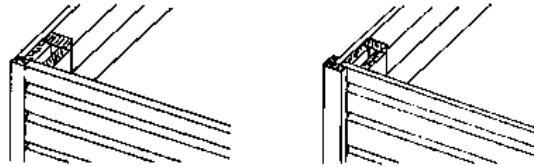
When fixing the boards to the frame only one nail is used in each stud for each board. The nail must be placed near the lower edge of the board as the top edge will be held in place by the next board. Only galvanized 50 mm jolthead nails are used as they do not rust. Each nail has to be punched immediately, taking care not to leave a hammer head impression on the boards.



Figure

c) Joining weatherboards at external and internal corners:

- External corner



Figure

- Internal corner

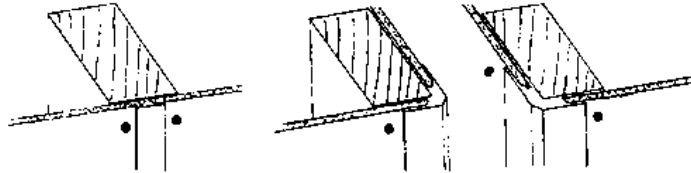


Figure

15.2. Fibre cement boards

The fibre cement boards are manufactured in a standard thickness of 4.5 mm and have different heights and widths. The studs should be spaced according to the width of the sheets. Where special size sheets are required, as over doors or under windows, sheets may be cut with a fibre cement cutter.

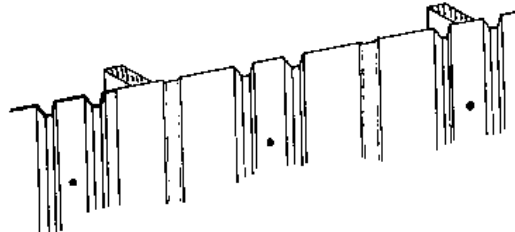
a) Nailing: - The sheets should be nailed along all edges to studs or noggings approximately 400 mm apart and 10 mm from the edges with clouthead nails. Where joints occur on a stud, plastic joints must be used .



Figure

15.3. "V" crimp iron

These boards are made from 0.8 mm metal sheet and are crimped "v" shape to strengthen the sheet. It is possible to buy it in different lengths. Only vertical nailing is possible with these boards. For nailing, only clouthead nails are used and are nailed at every corrugation.

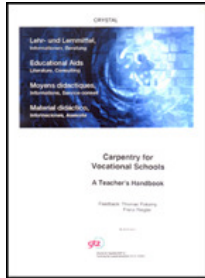


Figure



[Home](#) > [ar](#).[cn](#).[de](#).[en](#).[es](#).[fr](#).[id](#).[it](#).[ph](#).[po](#).[ru](#).[sw](#)

 **Carpentry for Vocational Schools - A Teacher's handbook (GTZ,**



252 p.)



16. FLOORING



(*introduction...*)



16.1. Different types of flooring boards



16.2. Laying of flooring boards



16.3. Finishing of flooring

Carpentry for Vocational Schools - A Teacher's handbook (GTZ, 252 p.)

16. FLOORING

TOPIC: 16. FLOORING

INTRODUCTION: This topic teaches students different types of flooring boards, how they are laid and how to finish the floor.

OBJECTIVES:

16.1. Students should be able to identify the different types of flooring and their characteristics.

16.2. Students should be able to describe the procedure and lay floor boards.

16.3. Students should be able to carry out the procedure of finishing a floor.

METHOD:

16.1. Prepare samples of different floor boards and display them in the classroom. Students take notes from the black board.

16.2., 16.3. These two chapters are difficult to demonstrate if there are no building projects going on.

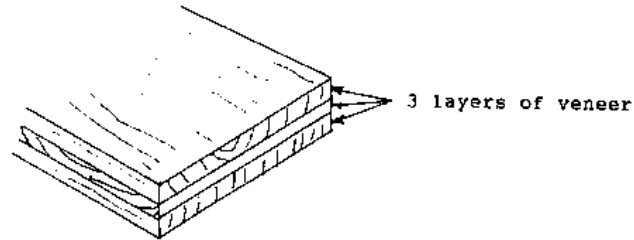
Prepare photocopies of the drawings from this topic which are glued into students trade theory book after the topic has been taught in the classroom.

NOTE: At the end of this section prepare a worksheet for students to complete as homework. They are to be corrected and assessed later.

The floor in a timber house may be laid and fixed as soon as the walls and the roof are covered.

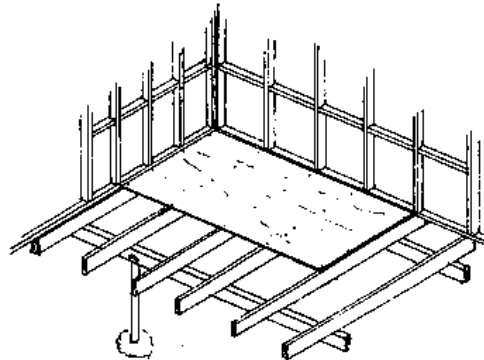
16.1. Different types of flooring boards

a) Plywood: - Plywood is made from thin pieces of timber called veneer, which are glued and pressed together. Plywood always has an odd or uneven number of veneers. The outside veneers are called face veneers, and they are of good quality, with no splits, cracks or defects in them.



Figure

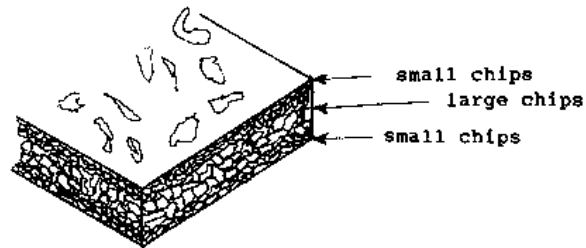
b) Laying plywood as flooring: - Plywood is a fast way of laying flooring. The thickness of the plywood should be 20 mm. The joints in the sheet must be made on a joist. Plywood sheets are nailed to the joists and the nail are punched immediately. Where special size are required, cut and fit them in.



Figure

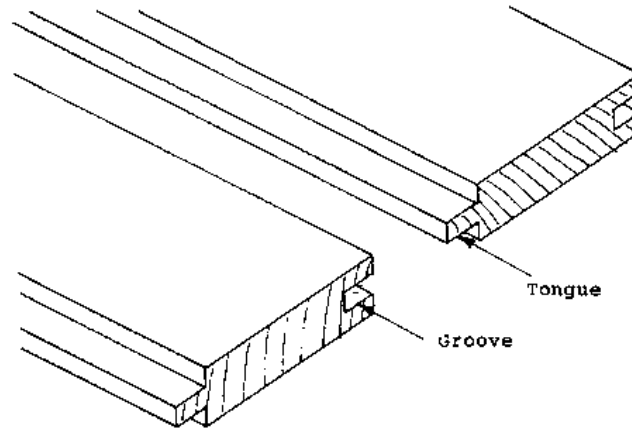
c) Chipboard: - This board is made from fine chips of timber which are glued together

by heat and pressure. The smaller chips are used on the outside faces to give a smooth finish and the bigger chips are used in the middle to lower the cost. Using chipboard as flooring, the thickness of the boards should be at least 20 mm, because the chipboard is quite porous. It cannot stand heavy loads and can easily break. In laying the boards as flooring boards the procedure is the same as for plywood flooring.



Figure

d) Flooring boards: - Flooring boards are sold by the linear metre. Flooring timber has a tongue and groove joint and is 22 mm in thickness.

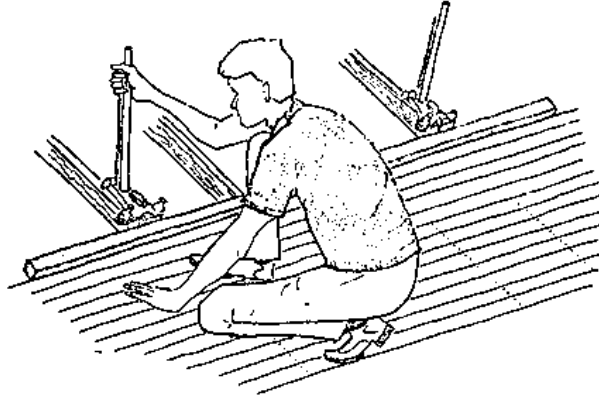


Figure

16.2. Laying of flooring boards

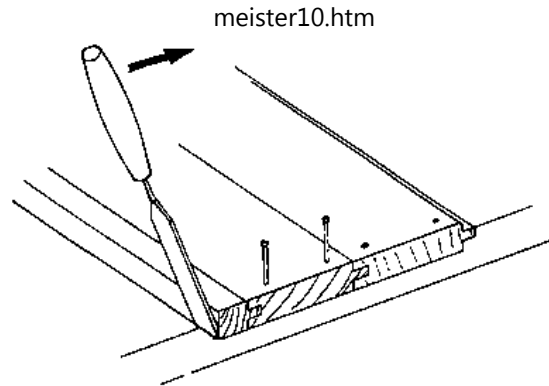
In laying flooring boards a pair of floor cramps or a chisel is used to ensure tight fitting joints. The flooring boards are cut to the required length with any joints cut centrally over the joist. The first board is nailed down against a wall with the groove-side outward. Upon the fixing of this board depends the straightness of all the others. If there is a big room, tie a rope in the middle of the room, lay a board which follows exactly the straightness of the rope and continue to lay the boards. Each flooring board is double nailed at each joist.

a) Using floor cramps: - Few boards are laid together, place a piece of hardwood (called a dogging piece) between the cramps and the boards to protect their edges and nail the boards immediately.



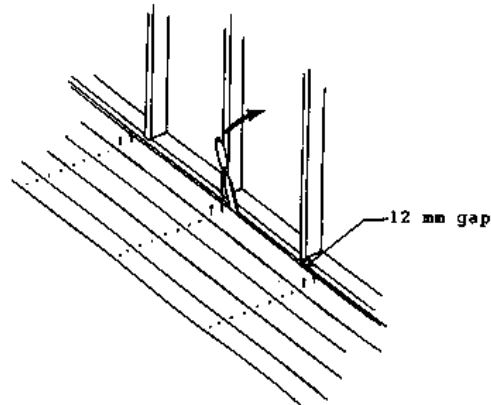
Figure

b) Using a chisel:- If floor cramps are not available, then one board at a time can be fixed by placing a block against the edge of the board and driving a strong chisel into each joist at the side of the block and lever with the chisel while the nails are being driven in.



Figure

c) Laying the last board: - When laying the last board on a cut in floor, leave 12 mm gap between the board and the wall plate. Tighten the last board using a chisel. Tack the nails in position first and then hammer the chisel into the joist and lever the last board in place. While maintaining the pressure, drive the nails home.



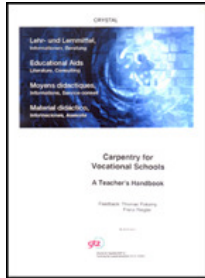
Figure

16.3. Finishing of flooring

If the flooring boards are nailed, the nails are punched with a nail punch. The nail holes and other holes in the surface of the floor are filled with putty, using a putty knife. Let the putty dry and the floor can be sanded. This work can be done with a floor-sanding machine, belt sander or sanding by hand. When the floor is sanded, varnish is brushed onto the floor. Best results are obtained by High Gloss varnish. Varnish does not dry quickly, and should be left for a full day before sanding and the application of a second coat.



[Home](#) > [ar.cn.de.en.es.fr.id.it.ph.po.ru.sw](#)



📖 **Carpentry for Vocational Schools - A Teacher's handbook (GTZ, 252 p.)**

➔ 📄 **17. ELECTRICITY**

📄 **(introduction...)**

📄 **17.1. Basic knowledge**

📄 **17.2. Fuse box**

📄 **17.3. Electricity accessories**

📄 **17.4. How to connect switch, power point, light and power plug**

📄 **17.5. Simple house wiring**

📄 **17.6. Alternate switching**

Carpentry for Vocational Schools - A Teacher's handbook (GTZ, 252 p.)

17. ELECTRICITY

TOPIC: 17. ELECTRICITY

INTRODUCTION: This section only teaches students the basics of electricity such as the technical *terms*; the different ways electrical power can be produced; the function of a fuse; different electricity accessories (tools, switches); connecting of lights, switches and power points to the power line and simple house wiring.

OBJECTIVES:

17.1. Students should be able to define technical terms like DC, AC, Active, Neutral, Earthing, Volt, Ampere and Ohm.

17.2. Students must be able to state the function of a fusebox and how many Ampere a fuse needs to secure lights and how many Ampere to secure power points,

17.3. To know the tools and accessories used in electrical installation work.

17.4. Students should be able to connect light switches and power points correctly.

17.5. Students should know how to install a simple wiring system in a house.

17.6. To define what a alternative switch means and how to make it.

METHOD:

17.1. Prepare for this lesson a battery light which you put in front of the class to show students one form of power which can be used.

Explain all the terms related to electrical power and what they mean. Students write it in their trade theory book.

17.2. Prepare a fusebox and demonstrate how wires are connected correctly and which fuses are used for main switch, power points and lights.

Prepare photocopies of a fusebox and students glue them in their trade theory books.

17.3. Prepare tools and accessories used for electrical installations and display them in the classroom.

Prepare photocopies of these tools to glue in the students book.

17.4. Prepare light, switch and power point to demonstrate how they are connected correctly to the power line. Prepare photocopies from the book for the students to glue in their trade theory book.

17.5. For this lesson prepare some lights, switches, power points, a fusebox and several meters of wire and connectors.

After explaining basic house wiring demonstrate it with the help of the students.

Before switching on the main fuse check all connections for correctness!

17.6. This chapter will only be explained because it is almost the same procedure as for chapter 17.5. the only difference being the connections to the switch. This system is rarely used in normal cases.

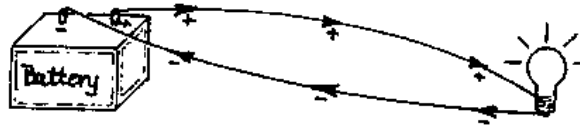
NOTE: At the end of this section prepare at least two worksheets for students to complete as homework in their nightstudies. Correct and assess them later.

Electricity has become an essential energy source in our daily lives. You are confronted with it everywhere. We use it during our work, at home and even for entertainment. If it is produced in a hydroelectric power station, it is very environment friendly too. The function of a hydro-electric power station is quite simple. The water of a river is directed into a channel. This channel leads to a turbine. The turbines driving-wheel is turned by the current of water. Because the turbine is connected to the generator, it gives the generator the turning movement and the

generator is able to produce electrical energy.

17.1. Basic knowledge

DC: - Direct current, electric current flowing in one direction. Eg. Battery. When the direct current flows, the lamp is able to light.



Figure

AC: - Alternate current that reverses its direction at regular intervals, the cycle being repeated continuously, the number of completed cycles per second being known as frequency. The symbol for frequency is hertz (Hz). It means one hertz stands for one cycle. We have 50 hertz per second which means 50 cycles for one second. Frequency = 50 Hz. The alternate current is produced by the generator. It does not matter if it is driven by a turbine or a diesel engine.

Active: - Where the electric current starts to move, never touch this wire. It will give you a shock. It is marked with plus (+).

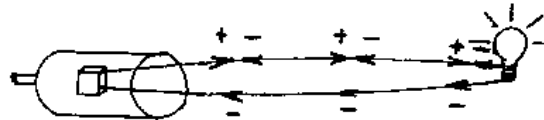
Neutral: - Where the electric current flows. It is marked with minus (-).

Earthing: - Earthing prevents you from getting a shock. Always connect the green-yellow wire to the earth when you connect a light, switch, powerplug or powerpoint.

Volt: - Volt is the unit for voltage. Voltage is the amount of electrical power in an electrical circuit if it is not interrupted. The electrical power is always 250 Volt. The word comes from the Italian physician Allesandro Volta who realised the force of electric energy.

Ampere: - Ampere is the electrical force. It is named after a French physician Andrew Marie Ampere. You can compare it with a bucket of water, if one bucket of water is equal 250 V. If you switch on a light it is enough to pour one $\frac{1}{4}$ of the bucket into the electrical circuit per second. If you use the thickness planer you have to pour 5 buckets of 250 Volt every second into the electrical circuit. This is the electrical force. It is called ampere and the lamp needs $\frac{1}{2}$ of one Ampere and the thickness planer needs 5 Ampere.

Ohm: - Ohm is the measurement of resistance, which occurs when electric energy is flowing. When we use the extension cord, you can feel that the extension cord gets warm. That happens because of the resistance. The same happens in a bulb. In a bulb there is a very thin wire. When electrical energy flows through this thin wire, it gets hot and gives off light. A lot off electrical energy would like to go through that thin wire, but because it is so thin, it provides high resistance and that resistance makes the wire hot



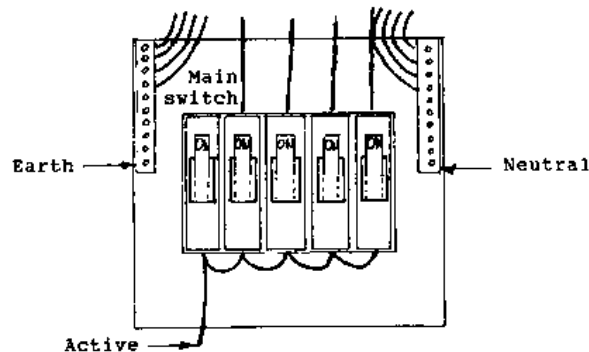
Figure

17.2. Fuse box

A fusebox consists of different fuses. At the main switch the power comes in and is distributed to the other fuses. Usually the light is secured with one 8 Ampere fuse and the powerpoints with two 15 Ampere fuses. The purpose of the fuse is to break the electrical circuit if it is overloaded. If an electrical circuit is overloaded for a long time the wires will melt and the house could easily catch fire. Make sure that the electrical circuit has the correct fuse.

The fuse itself can consist of wire which will melt and break the circuit. Once the fusewire is broken, replace it with the same thickness.

The other type of fuse is the bmetal fuse, which is getting more popular. This fuse has two special metal strips in it and when they become hot, they bend and break the circuit. Afterwards, when they cool down, you can switch the fuse on again. They are much easier to handle than the wire fuses.



Figure

17.3. Electricity accessories

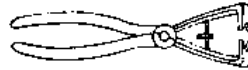
a) Tools:

- **Screwdriver**



Figure

- **De-sisalation pliers**



Figure

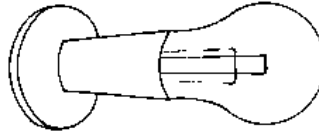
- **Combination pliers**



Figure

b) Accessories:

- **Bulb with Batten holder**



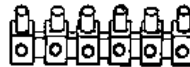
Figure

- **three core flex**



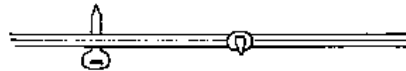
Figure

- **Connector**



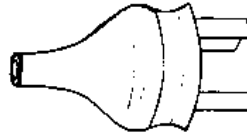
Figure

- **Cable Clips**



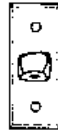
Figure

- **Three pin plug**



Figure

- Rocker switch



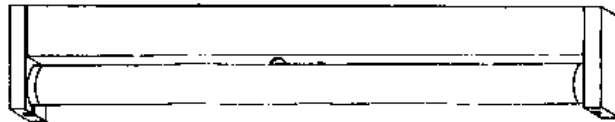
Figure

- Single powerpoint



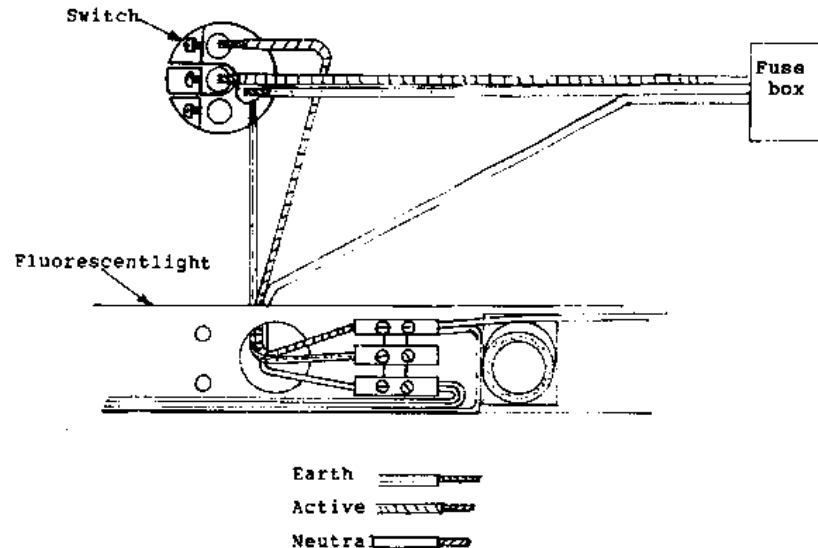
Figure

- Fluorescent light

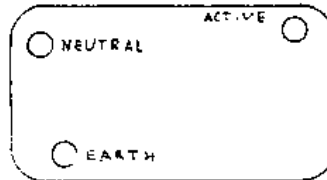


Figure**17.4. How to connect switch, power point, light and power plug**

a) **Light and switch:** - The active line and the earth wire go to the switch and from there to the light. The neutral wire goes direct to the light. Make sure that the active line wire is connected in the right way at the switch. Strip back the insulation just enough to allow the bare wires to be clamped tightly under the head of terminal screws without pieces sticking out.

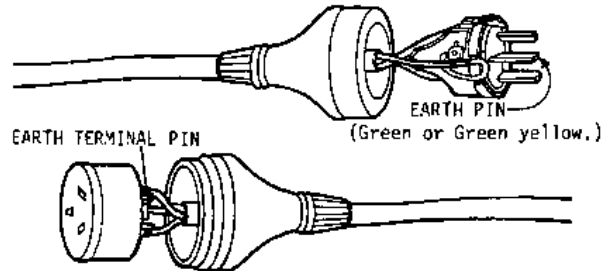
**Figure**

b) Powerpoint: - Usually at the back of the powerpoint it explains where to connect the wires. Just follow the instructions and tighten the terminal screws.



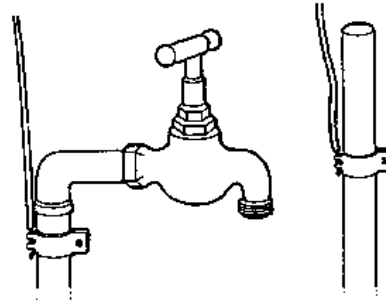
Figure

c) Three pin plug:- Make sure you connect the earth at the right terminal. For the active line and neutral wires it does not matter which pins you use.



Figure

d) Main earth wire: - Usually the main earth wire is connected to a metal rod driven into the ground.

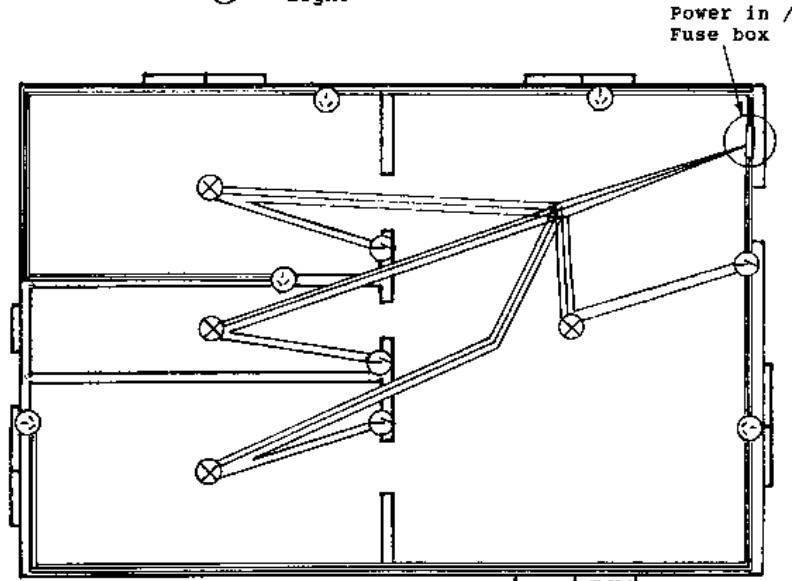


Figure

17.5. Simple house wiring

You must start from the fusebox. The main active line wire is connected to the mains switch in the fusebox. From there, the main active wire is distributed to three other fuses. One fuse is for the light and two fuses are for the power-points. A three core flex wire is distributed to the lights to make one electrical circuit and secured by one fuse. For the powerpoints you have to make two electrical circuits and secure them by two fuses. At the fusebox always connect the three core flex wire, earth to earth terminal, neutral to neutral terminal and active line to the fuse. The power-points usual mark where to connect the earth, neutral and active wire. At the light you have to be careful. Neutral and Earth are directly connected to the light, but Active has to go to the switch first and from there to the light. The earth from the switch is connected to the earth of the light.

- Ⓢ - Powerpoint
- Ⓢ - Switch
- ⊗ - Light

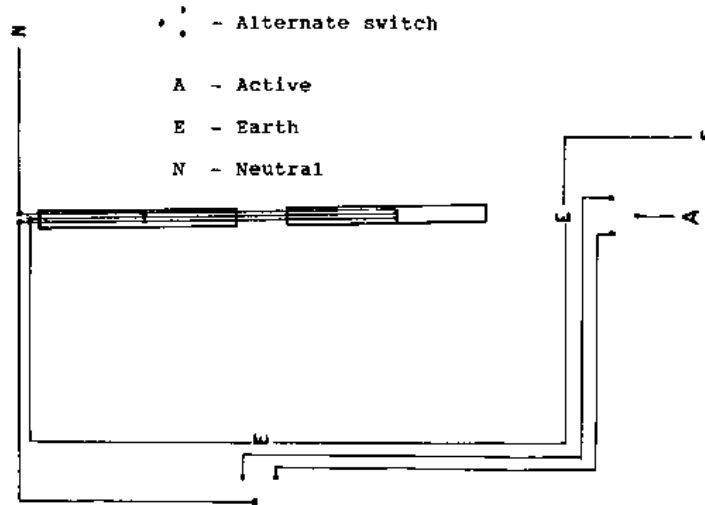


Figure

17.6. Alternate switching

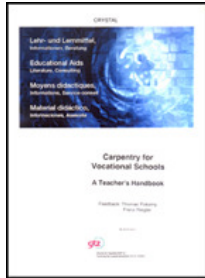
With the alternate switch you are able to switch on or off the same light from different switches. For that kind of switching you need a special switch called an alternate switch. The terminals of this kind of switch are marked with C,1,2 and loop.

C at the first switch is connected to the active wire (usually red coloured). In that terminal the power comes in. Now you take an other three core flex wire and connect the red wire of the new three core flex wire to 2 and earth to earth. This core flex wire has to go to the other switch and repeat the connecting: red to 1, black to 2 and earth to earth (marked with loop). Then the terminal screw at the switch, which is marked with **C** is connected with one wire to the light. The neutral from the light has to go to the neutral of the fusebox.



Figure





 **Carpentry for Vocational Schools - A Teacher's handbook (GTZ, 252 p.)**

 **(introduction...)**

  **PREFACE**

 **1. TIMBER**

 **2. SCALES**

 **3. CONCRETE**

 **4. CONCRETE FORMWORK**

 **5. FOOTINGS**

 **6. TOOLS USED ON BUILDINGS**

 **7. FASTENERS**

 **8. FOUNDATION**

 **9. JOINTS**

 **10. BRACING**

 **11. WALLFRAME**

 **12. CEILING**

 **13. ROOFING**

 **14. WINDOWS**

 **15. OUTSIDE CLADDING**


 **16. FLOORING**

 **17. ELECTRICITY**

 **18. PLUMBING**

 **19. INSIDE CLADDING**



- 20. DOORS**
- 21. SKIRTING, ARCHITRAVES, CORNERSTRIPS**
- 22. PAINTING**
- 23. STAIRS**
- 24. HARDWARE**
- 25. WATERTANKS**
-  **BIBLIOGRAPHY**

PREFACE

Austrian Volunteers have been working in Carpentry Vocational Centres for many years but it has always been difficult to find proper material for teaching which covers all the skills necessary to build a house.

Therefore we wrote this book to help teachers in carpentry schools to improve their lessons and to give a general View of what can be taught on the subject.

We know that we only have touched some topics, like Plumbing and Electricity, but the aim upon is only to give some basic knowledge. Because, in building houses in rural areas, it is not yet essential to have water and electricity in the house.

So we put all our emphasis on the construction of the house and the tools and materials which are needed to do it.

The method references for each topic mentioned in this book are only tips and must not be followed exactly but according to your own experience. Teaching is much more effective when topic related materials are shown and practicals are carried out.

Teachers should be aware of the fact that the whole book is far too much to be taught in a two year vocational training course.

This book is not supposed to be a lesson programme. Therefore, it is up to each school and their teachers to focus or select topics and design their own syllabus and lesson programme.

With this book we hope to give you some assistance in teaching the students the knowledge necessary to carry out carpentry work when they leave school and go back to their respective villages or try to find work in a company.

Finally we like to thank the Austrian Service for Development Cooperation for their financial assistance which has enabled us to publish this book.

Mt Hagen, 11th April 1991

**Thomas Pokorny
Franz Riegler**



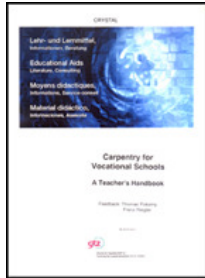
[Home](#) > [ar.cn.de.en.es.fr.id.it.ph.po.ru.sw](#)

 **Carpentry for Vocational Schools - A Teacher's handbook (GTZ, 252 p.)**

➔  **18. PLUMBING**

 **(introduction...)**

 **18.1. Water pipes**



18.2. Plumbing tools

18.3. Plumbing fittings

18.4. Guidelines for plumbing

Carpentry for Vocational Schools - A Teacher's handbook (GTZ, 252 p.)

18. PLUMBING

TOPIC: 18. PLUMBING

INTRODUCTION: This section teaches students the different types of pipes used in plumbing, tools and fittings as well as guidelines to be followed when doing plumbing work.

OBJECTIVES:

18.1. Students should be able to identify the different types of pipe used for plumbing and their common sizes.

18.2. Students should be able to identify all plumbing tools and describe their characteristics and uses.

18.3. Students should be able to identify all fittings used for plumbing work.

18.4. Students should be able to plan their own water system and construct it.

METHOD:

18.1. Prepare samples of different water pipes and display them in the classroom for students better understanding.

Explain with the aid of a blackboard the uses of the different pipes and give the table with the conversion of pipe diameters from inches to millimetres.

18.2. For this lesson prepare all plumbing tools available and display them in the classroom.

When enough time is available demonstrate how these tools are used correctly. Like cutting and threading pipes.

Prepare photocopies of all plumbing tools for students to glue in their trade theory book.

18.3. All plumbing fittings available are displayed in the classroom.

After distributing prepared photocopies of all plumbing fittings to students explain and demonstrate their use by joining them to a small water system.

Students glue the copies in their trade theory book.

18.4. Prepare photocopies of the diagram of a water system and distribute it to students.

Also prepare all pipes and fittings needed for this system.

Build, with students, this water system by following the numbers of pipes and fittings.

Do not glue it so that it can be disassembled after the lesson and be used again.

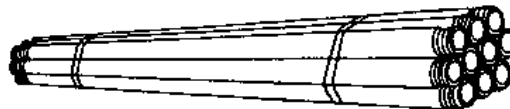
NOTE: At the end of this topic prepare at least two worksheets for students to complete as part of their nightstudies. Correct and assess it later.

Plumbing is usually done by a trained plumber or pipe fitter. Because of the many special tools used in plumbing and the wide range of different pipes and water systems, special knowledge is needed to do plumbing properly. However, this chapter will enable you to learn the basics of plumbing, some tools, fittings, pipes and give some guidelines to follow.

18.1. Water pipes

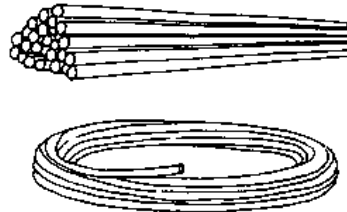
Water supply pipes are classified into three basic groups. a) Galvanized steel pipes:

- These pipes have a threaded end to fit to the threaded fittings.**
- Galvanized steel pipes are used for external plumbing from the tank to the house, underground, under the floor and for supplying water to outside taps.**

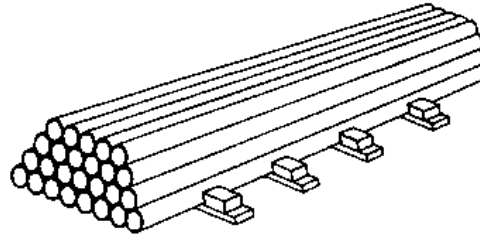


Figure**b) Copper pipes:**

- These pipes are for solder joints and flare joint fittings.
- Copper pipes are used for distributing the water inside, the house to all applications (shower, sinks, toilets) and are mostly laid in the wall because they are of small diameter and is easy to bend. Copper pipes are also used for hot water systems.

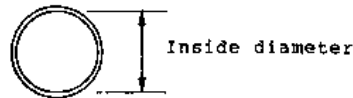
**Figure****c) PVC, or Plastic pipes:**

- These pipes are for adhesive fittings or connections.
- PVC-pipes are best suited for external use, as underground or sewer pipes.
- PVC-pipes are commonly used in rural areas because they are much easier to cut and connect than any other pipes and few tools are needed.



Figure

d) Pipe measurements: - Pipes are always measured by inside diameter usually in inches.



Figure

Pipes are available in sizes of:

1/2" = 15 mm

3/4" = 20 mm

1" = 25 mm

1 1/4" = 32 mm

1 1/2" = 38 mm

2" = 50 mm

3" = 75 mm

4" = 100 mm

5" = 125 mm

6" = 150 mm

18.2. Plumbing tools

When planing the plumbing work, you must decide which type of pipes to use. Your choice will depend on the plumbing tools available. As plumbing with steel pipes requires a lot of different tools to cut, bend, thread and join the pipes, it is less practical for village plumbing, because of the high costs of these tools.

Plumbing with PVC-pipes and copper-pipes need only a few tools because pipes need not to be threaded due to the fittings which are either glued (PVC-pipes) or connected with special designed flare connectors (Copper-pipes).

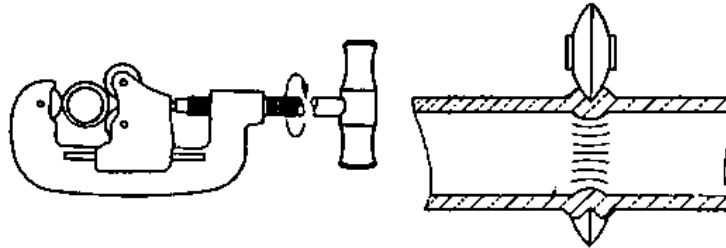
Below follows a list of the most important tools for plumbing with steel, copper and PVC pipes.

a) Hacksaw: - Used for steel, copper and PVC-pipes.



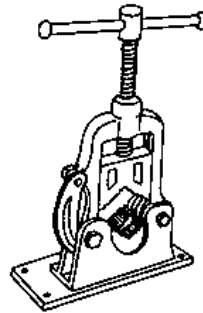
Figure

b) Pipe cutter: - For steel, copper and PVC pipes. Pipe cutters do not remove any metal. The wheel squeezes the metal and forces it ahead of the cutter until the pipe is cut through the wall thickness.



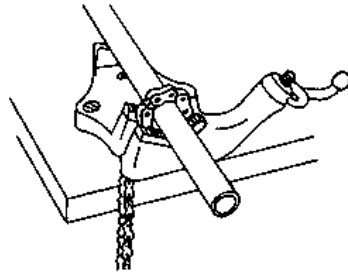
Figure

c) Self-locking, hinged pipe vice: - For steel pipes only. Pipes to be cut or threaded must be held steady and prevented from rotating by holding them in a suitable vice.



Figure

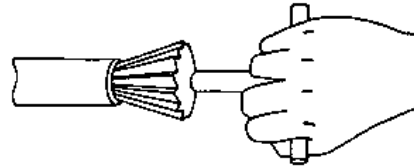
d) Chain pipe vice: - For steel pipes only. These vices are made to hold pipes with outside diameters up to 8" (200 mm). They are mounted on solid benches.



Figure

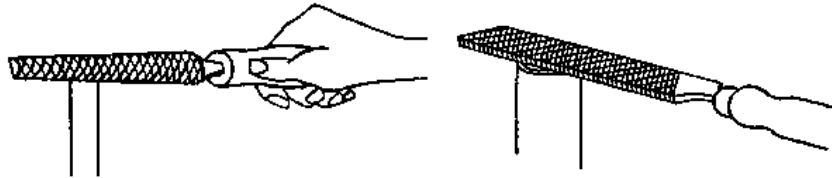
e) Pipe reamer: - For steel-pipes only.

To remove internal burrs caused by cutting pipes. Several types of tapered reamers are available from 1/2" to 2" with a cross handle.



Figure

f) File: - File off all the outside burrs of the galvanized steel pipe with a flat bastard file or with a halfround bastard file.



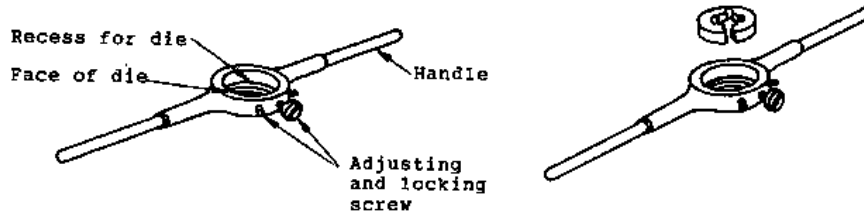
Figure

g) Stock and die:

- For steel pipes only.

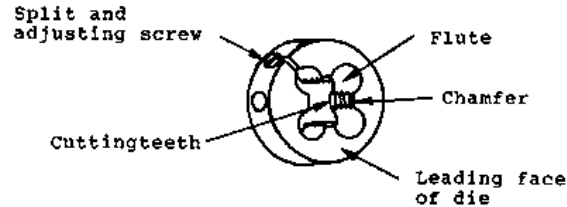
These are stock and dies for cutting external threads on bars and small pipes up to 1" .

- The stock is a suitable frame with handles to hold and rotate the die.

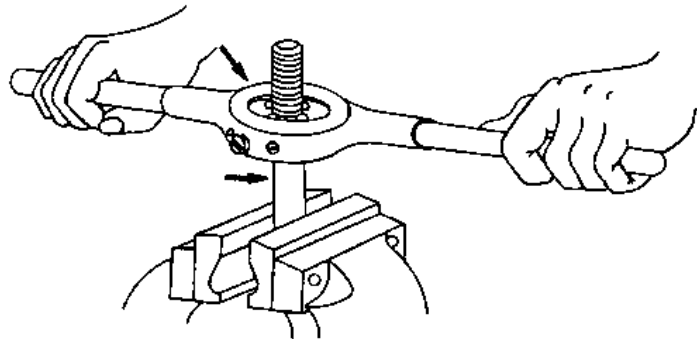


Figure

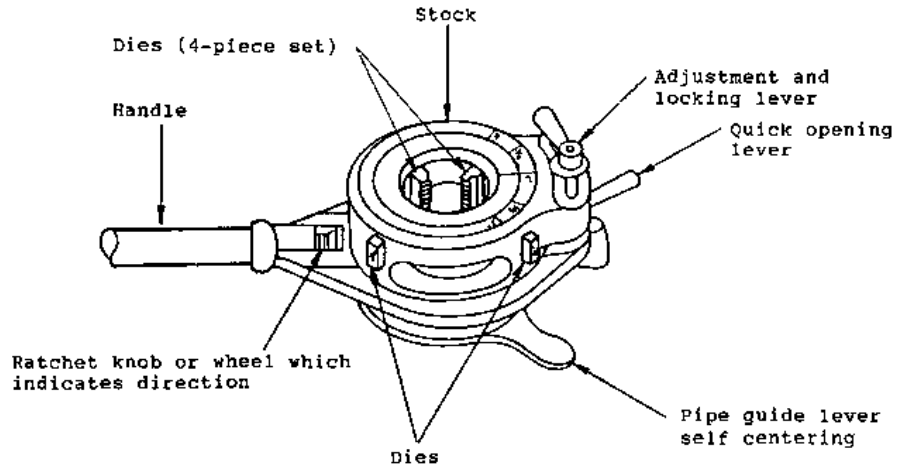
- These dies are used to cut external threads.

**Figure**

- The die must be set exactly at an angle of 90 degrees to the bar or pipe-end and is pressed firmly against the end while rotating the stock clock wise until - the length of the thread is cut.
- Reverse and rotate the stock carefully anti-clock wise. Then repeat to clean out the thread.

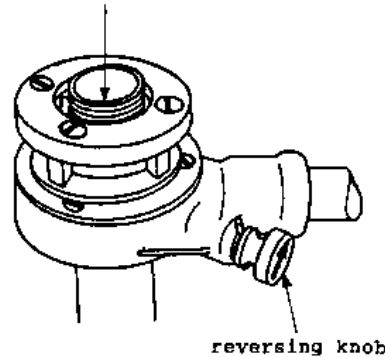
**Figure****h) Ratchet stock and die:**

- For steel pipes only. It works in the same way as the other model but is adjustable from 1/2" to 2" and the single cutter can be exchanged.
- It has only one handle and when reversing, the knob has to be turned around.



Figure

cutted thread



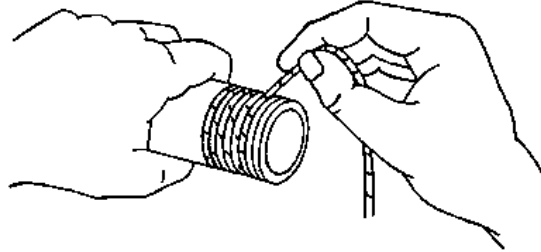
Figure

- The length of a pipe thread should be between 15 mm and 35 mm long - depending on the pipe diameter.

i) sealing threads:

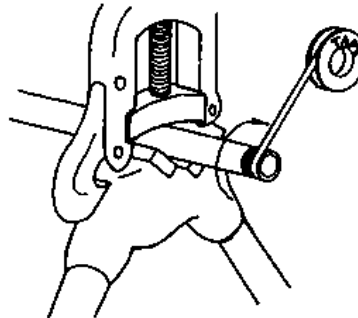
- For steel and PVC threads. Threads must be sealed to ensure a completely tight joint between pipe and fitting.

- Hemp string: For steel threads. Wind it in the same direction as the male thread.



Figure

- Seal tape: For steel and PVC threads. If using sealing tape, unroll a sufficient length of tape and wrap it around the male thread as shown.



Figure

j) Stillson pipe wrench:

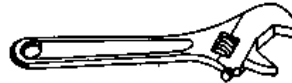
- It is used for all types of pipes with 1/2" to 2" diameters.

- The stillson pipe wrench is designed as a heavy duty tool to withstand rough handling and heavy work. The jaws give a immediate and positive grip.



Figure

k) Adjustable spanner: - For tightening or loosening connectors. Available in different sizes for pipe fittings up to 2".

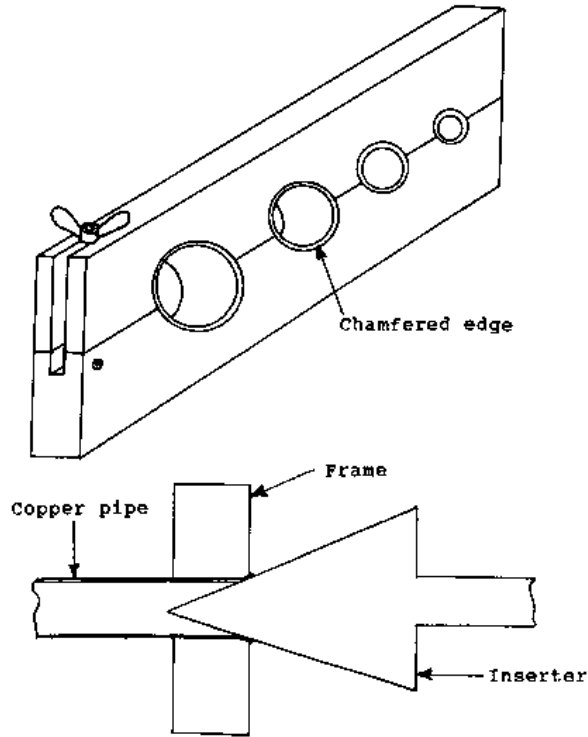


Figure

l) Tube flaring tool set:

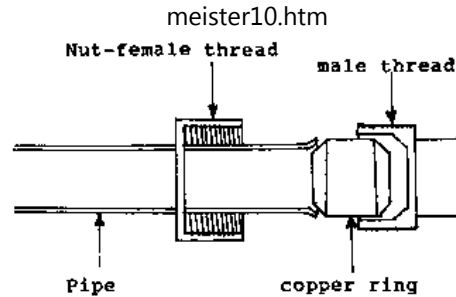
- Only for copper pipes. Copper pipe-ends must be flared to fit with the copper ring used by connectors which are tightened with a nut to the pipe.

- The flaring tool consists of two parts. The part in which the pipe is fastened, and the sharp pointed inserter which is forced with a hammer, or with a spindle into the end of the pipe to widen it.



Figure

- This job must be done with accuracy to ensure a sealed joint.



Figure

18.3. Plumbing fittings

Fittings are used when installing pipes to go around corners, to join pipes, to reduce the diameter of the pipes and to set taps.

The fitting system for PVC and steel pipes is the same. For steel pipes only steel fittings are used, while for PVC pipes PVC and steel fittings can be used because the threads are the same size. For PVC pipes many fittings can be glued with a "PVC solvent cement".



Male socket threaded



Female socket threaded



Plug



Reducing male socket



Reducing female socket



Bushes



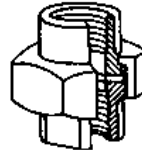
Tee - joint



Cross - joint



Back nut



Union



Double female Elbow 90 deg. threaded



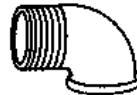
Double female Elbow 45 deg. threaded



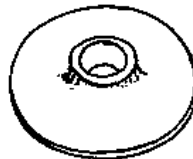
PVC-Elbow plain



PVC - Elbow + Inspectioneye



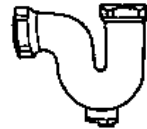
Male - Female Elbow



Flange



'S'- Trap



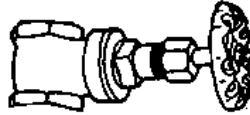
'P'- Trap



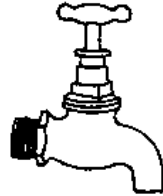
Floor waste



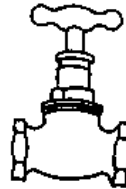
Floor waste cup pattern



Gate valve



Bip - Cock



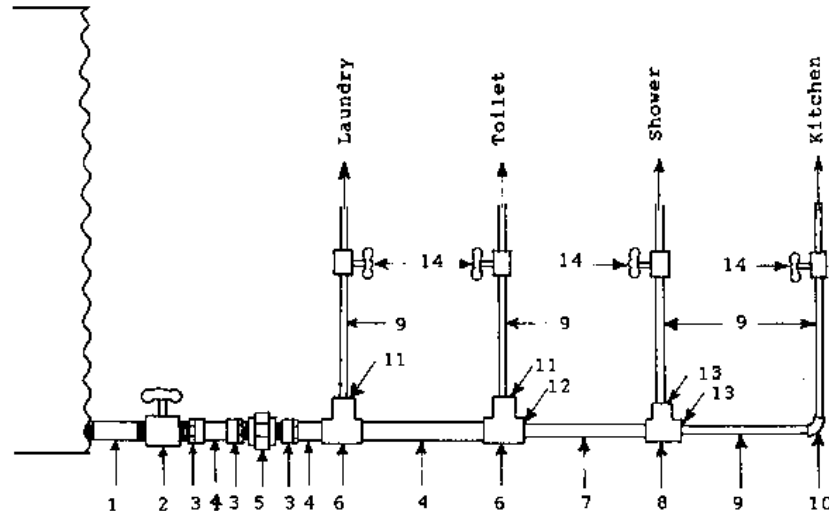
Stop - Cock



Hose - Cock

18.4. Guidelines for plumbing

The most important thing is to make sure the water pressure is sufficient for all taps in the house. To ensure that, the watertank must be at least 500 mm higher than the highest tap in the house (most probably the shower). The more taps there are in a house, the larger the tank outlet must be to be able to reduce the pipe diameter after every second tap.



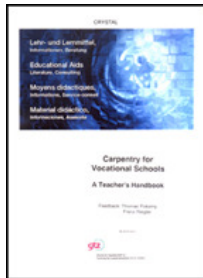
Figure

Description:

1. 1" galv. pipe two end threaded
2. 1" Gate valve
3. 1" PVC connector male thread, female glued
4. 1" PVC pipe
5. 1" galv. Union
6. 1" PVC Tee-joint
7. 3/4" PVC pipe
8. 3/4" PVC Tee-joint
9. 1/2" PVC pipe
10. 1/2" PVC Elbow 90 degr. female
11. 1" - 1/2" Bush
12. 1" - 3/4" Bush
13. 3/4" - 1/2" Bush
14. 1/2" control gate valves



[Home](#) > [ar](#).[cn](#).[de](#).[en](#).[es](#).[fr](#).[id](#).[it](#).[ph](#).[po](#).[ru](#).[sw](#)



 **Carpentry for Vocational Schools - A Teacher's handbook (GTZ, 252 p.)**

  **19. INSIDE CLADDING**

 **(introduction...)**

 **19.1. Plywood painted**

 **19.2. Plywood varnished**

Carpentry for Vocational Schools - A Teacher's handbook (GTZ, 252 p.)

19. INSIDE CLADDING

TOPIC: 19. INSIDE CLADDING

INTRODUCTION: This topic teaches students different possibilities of covering the inside walls with plywood.

OBJECTIVES: 19.1., 19.2. Students should know how plywood is nailed when it is either painted or varnished, and how to prepare it for painting or varnishing.

METHODS: 19.1., 19.2. Prepare two pieces of plywood with a straight edge and two pieces of plywood with a chamfered edge.

Show them to students and explain their advantages and disadvantages.

Explain to students how the plywood is nailed correctly and how the surface has to be before painting or varnishing can start.

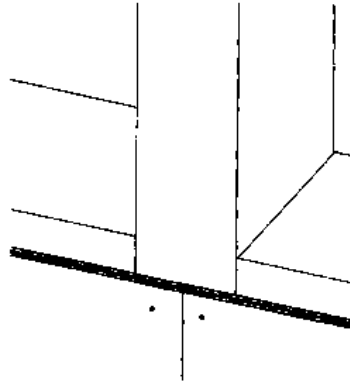
Students only take notes from the blackboard.

NOTE: At the end of this topic prepare a worksheet for students to complete as homework before the next lesson.

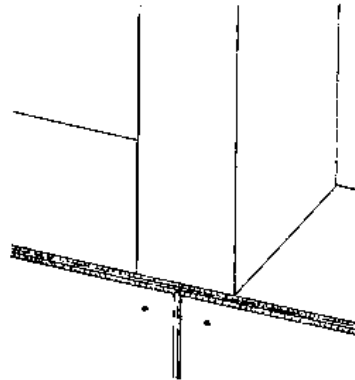
Ensure all studs and noggings are flush with plates and that badly bowed studs have been straightened. Plywood, usually 4 mm in thickness, is fastened to frames by nails. The nails are approximately 25 mm long and jolt headed. They should be placed 200 mm apart and 10 mm from the sheet edges.

19.1. Plywood painted

If plywood is painted it does not matter which direction the grain structure is showing. It does not make any difference if the grain structure shows horizontally like below windows or above doors. The butt end joints must fit firmly. Butt end joints can be straight or chamfered. The nails have to be punched below the plywood surface and the holes are filled with putty. When the putty is dry, sand it and apply prime coat, undercoat and finish coat.



Straight butt joint



Chamfered butt joint

19.2. Plywood varnished

If plywood is varnished, care has to be taken that the plywood sheets are nailed only vertically and the surface of the plywood is in good condition. For nailing use 25 mm zinc-coated jolt head nails. The nails are driven just below the surface with a nail punch. The nail holes are not puttied, just sand the plywood and apply the first coat of varnish. After the first coat is dried up, sand it and apply the second coat. The joints are usually butt joints, where the edges again can be straight or chamfered.



[Home](#) > [ar.cn.de.en.es.fr.id.it.ph.po.ru.sw](#)

 **Carpentry for Vocational Schools - A Teacher's handbook (GTZ, 252 p.)**



- ➔ **20. DOORS**
 - (introduction...)**
 - 20.1. Door frame**
 - 20.2. Calculating of opening**
 - 20.3. Fixing door jambs**
 - 20.4. Hanging a door**
 - 20.5. Types of doors**

Carpentry for Vocational Schools - A Teacher's handbook (GTZ, 252 p.)

20. DOORS

TOPIC: 20. DOORS

INTRODUCTION: This topic teaches students how a door frame is made; how the opening for a door is calculated; how the door jambs are fixed into the wall frame; how a door is correctly hung; the mounting of locks and different door types.

OBJECTIVES:

20.1. Students must know the names of the parts of a door frame and how they are joined.

20.2. Students should be able to calculate the opening for a door frame in the wall frame.

20.3. Students should know the procedure for fixing door jambs in a wall

frame.

20.4. Students must be able to fit hinges, door stops and locks correctly.

20.5. Students should be able to distinguish between different types of doors and define their characteristics and uses.

METHOD: This topic is taught first in the classroom and it might be difficult to demonstrate it on a real door except if a building project is going on where doors have to be hung anyway.

Prepare photocopies from the drawings on this topic to glue in the trade theory book after the topic is taught and copy the text from the blackboard.

When time is available some exercise can be made on fitting hinges and locks to a small piece of wood which is the same thickness as a door.

NOTE: At the end of this topic a worksheet is prepared for students to complete for their nightstudies.

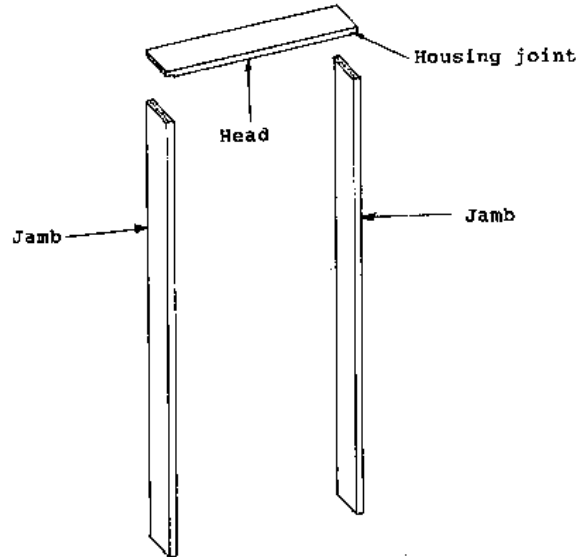
The worksheets are corrected and assessed later.

There are a lot of different door types. External doors have to be much stronger than internal doors. Usually external doors are timber framed doors and for internal doors are the hollow core flush door type. Doors are hung to the doorframe by hinges.

20.1. Door frame

The timber thickness for the doorframe is between 20 mm to 25 mm. The width of the

frame depends on the wall width. The jambs are joined to the head by housing joints and nails. Before nailing the frame together, putty the timber and sand it.



Figure

20.2. Calculating of opening

To calculate the width of the door opening , measure the width of the door, add two jambs thickness and 4 mm. To calculate the height of the opening, measure the height of the door, add head and 4 mm.

E.g. Width:

Doorwidth	820 nun
Thickness of 2 jambs	+ 50 nun
	+ 4 mm

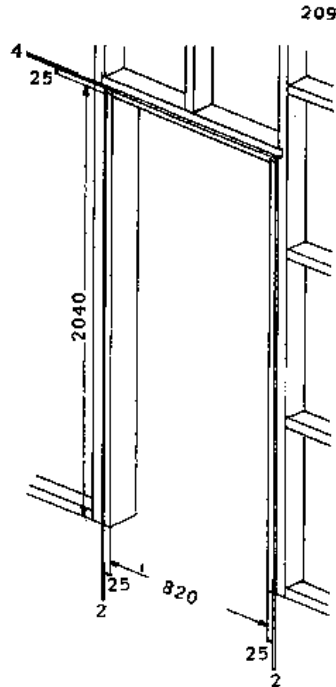
Width of opening in the wall = 874 mm

Height:

Doorheight	2040 mm
Thickness of one head	+ 25 mm
	+ 4 mm

Height of opening in the wall = 2069 mm

Door opening in the wall = 874 x 2069

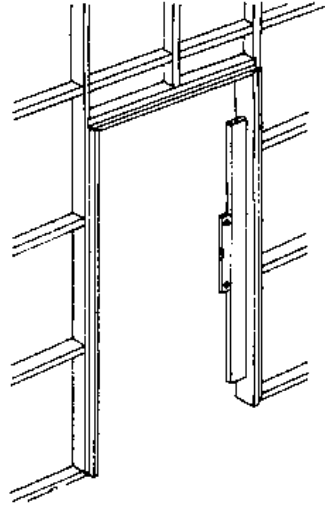


Figure

20.3. Fixing door jambs

Measure the height of the opening and cut the door jambs at that measurement. When the door jambs fit into the opening check the level of the head. Is the head not level cut the longer jamb shorter until the head is level. Afterwards test with a spirit level

and a straight edge whether the jambs are straight and level. If there is clearance between the stud and the jamb, pack timber between. The jambs are packed until they are straight and plumb on the face and the edge side. Finally, check if the edge side is in line with the wall cladding and start nailing.

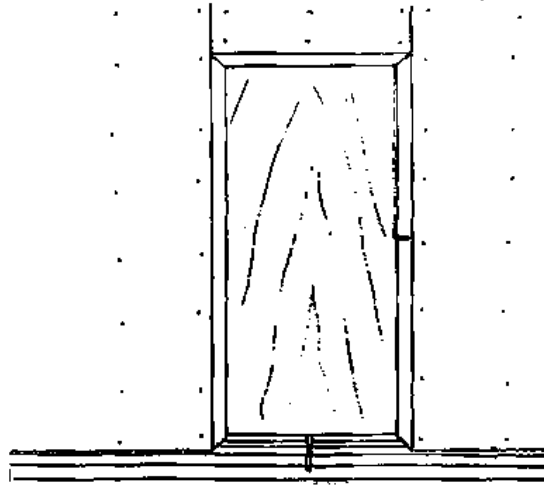


Figure

20.4. Hanging a door

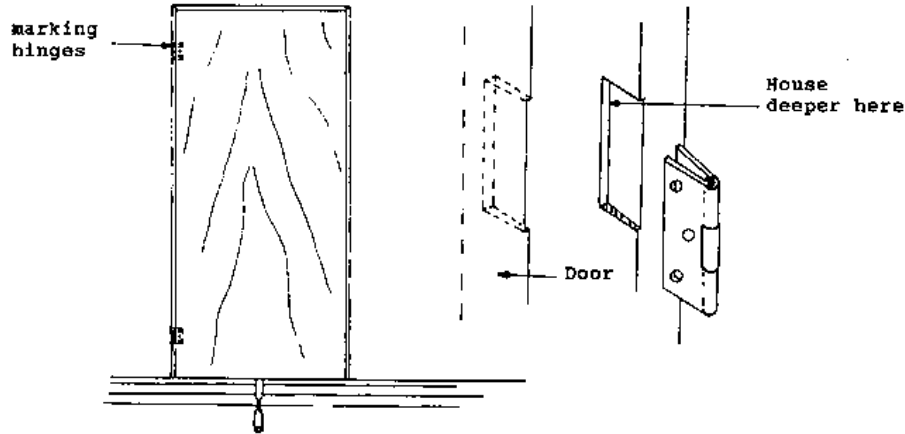
Hold door against jamb. The door may not be at the right height and width. Make marks at the top and at the side. When marking the door, mark it with a clearance between jamb and door. This clearance is usually 1 to 2 mm. Plane down the edges of the door until it reaches the pencil line and put the door into the jamb for testing. If

the door still does not fit, mark it again and plane it.



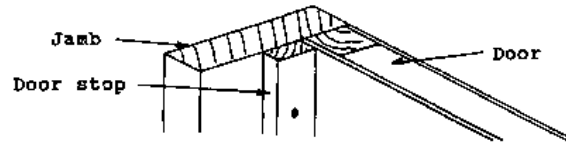
Figure

a) Hinging: - Put the door in the jamb and press it with the aid of a chisel into position. Take a hinge and mark across on both door and jamb. Remove the door and house the butt hinges at the door and jamb. Screw the hinges at the door. Hold door at right angles, and wedge it with chisel under outer edge, push top hinge into place and enter one screw. Remove wedge, put one screw in the bottom hinge, close and test for clearance. If it fits drive the other screws home.



Figure

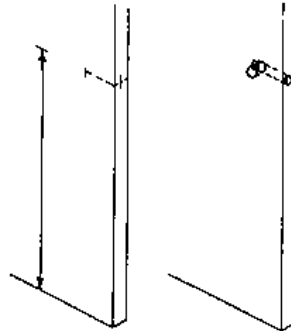
b) Fixing stops: - These should be finished with a smoothing plane and glass paper. Fit the top piece in first and find position with door closed, allowing for thickness of paint. Cut upright stops in tightly, tack in position and try. If the stop against hinge edge is too close, it will cause the door to bind.



Figure

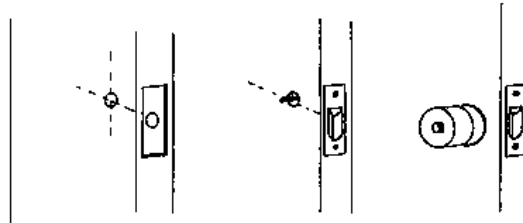
c) Door handles and latchsets:

- Latchsets and snibsets are normally fitted to internal doors and locksets to external or security doors. The first step for installing a latchset is to slide wedges under the door to keep it firm to work on. Square a line at latch height on edge of door to handle position. Mark position for holes for cylinder or tubular latch and mark the hole for locking mechanism plus a little room for play. If mortise locks are being used, drill a series of holes to the depth and height of the mortice mechanism and chisel the remaining wood away. Again allow a little room for play.

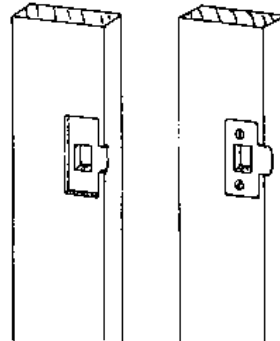


Figure

- To rebate the edge of the door to accept face of latch, install latch in hole and mark the outer edges of the flanges on the door. Using a chisel, rebate to the depth of the flange thickness, ensuring a flush fit. Install latch and handle mechanism. Adjustments may be required to enable latch bolt to move freely. Often a binding latch is the result of too tight a fit.

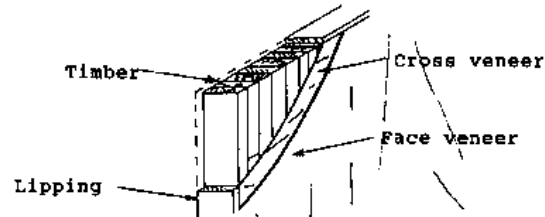
**Figure**

- Install striker plate on jamb by first closing the door and marking the position of the latch in the jamb. Rebate the housing for the striker plate. Also drill and chisel the hole to receive the latch bolt and attach striker plate. Door stops can now be fitted.

**Figure**

20.5. Types of doors

a) Solid core flush door: - This type of door is normally used as an external door where added strength is needed.

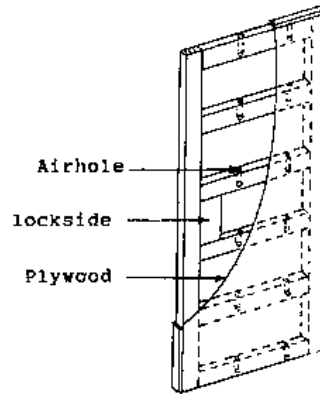


Figure

b) Hollow core flush door: - The hollow core door is light in weight and is used both as an internal and external door. Waterproof plywood and glue is used on external doors. An indication of lock side is necessary on hollow core doors. These type of doors are mass produced in standard sizes.

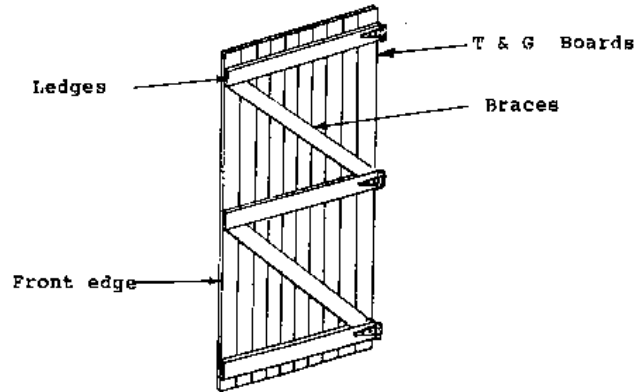
The standard thickness is 35 - 40 mm.

The standard height is 2040 mm. The standard widths are 610 mm, 760 mm and 820 mm.



Figure

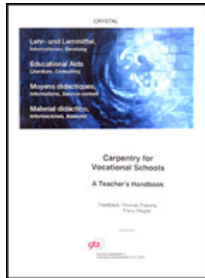
c) Braced and ledged door: - This door is mainly used in sheds and out houses. The sheeting is normally made of flooring boards with the face edges chamfered. The boards are nailed or screwed to the ledges after which the braces are fitted and fixed. The braces always go from hinge side up.



Figure



[Home](#) > [ar](#).[cn](#).[de](#).[en](#).[es](#).[fr](#).[id](#).[it](#).[ph](#).[po](#).[ru](#).[sw](#)



 **Carpentry for Vocational Schools - A Teacher's handbook (GTZ, 252 p.)**

➔  **21. SKIRTING, ARCHITRAVES, CORNERSTRIPS**

 **(introduction...)**

 **21.1. Shapes**

 **21.2. Cutting and joining**

Carpentry for Vocational Schools - A Teacher's handbook (GTZ, 252 p.)

21. SKIRTING, ARCHITRAVES, CORNERSTRIPS

TOPIC: 21. SKIRTING, ARCHITRAVES, CORNERSTRIPS

INTRODUCTION: This topic teaches students different shapes of cornerstrips, architraves and skirtings and how these are cut and joint correctly.

OBJECTIVES:

21.1. Students should be able to define the terms: Architrave, Skirting, Cornerstrip and identify different shapes by their names.

21.2. Students are expected to be able to cut and join cornerstrips, architraves and skirtings exactly at either 90 degrees or 45 degrees and to fit them properly.

METHOD:

21.1. Prepare different types and shapes of cornerstrips, skirtings and architraves and display them in the classroom.

Explain by referring to the cornerstrips architraves and skirtings on doors, windows and corners of the classroom to their purpose.

Write the necessary information on the blackboard and students copy into their trade theory book.

21.2. Prepare a mitre box and pieces of cornerstrips and demonstrate how to mitre cut strips correctly.

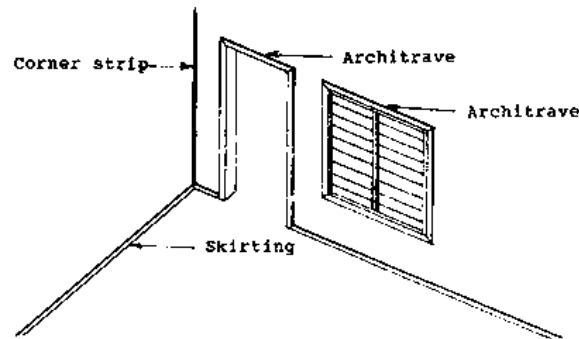
Write the procedure for cutting and fitting strips on the board and students copy into their trade theory book.

NOTE: At the end of this topic a worksheet is prepared to reinforce tillings learnt. Students have to complete it as homework. Worksheets are then collected for correction and assessment.

Skirting is the moulded badeboard around a room. It is fixed at the junction of the wall and the floor for protection to the wall cladding which would otherwise be damaged by brooms and chair legs.

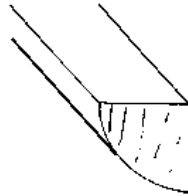
Architrave is the cover piece between the wall and the jamb being of an opening.

Cornerstrips are used to cover the joints of the plywood, which occur in the corners.

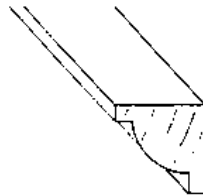


Figure

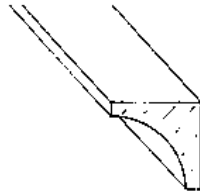
21.1. Shapes



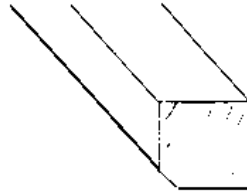
Quadrant



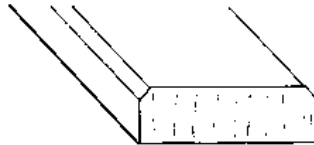
Ovolo



Scotia



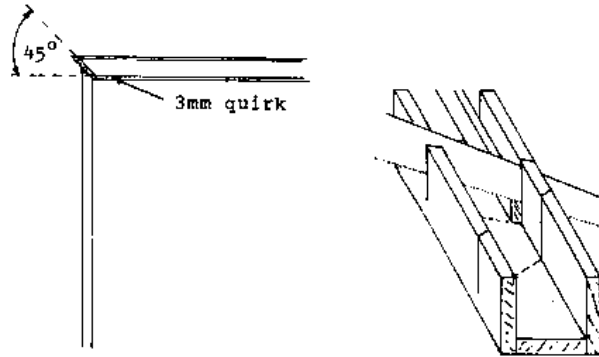
One side chamfered



Two sides chamfered

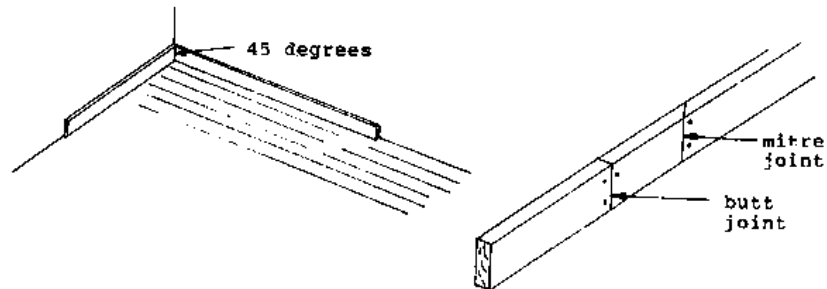
21.2. Cutting and joining

a) Architrave: - On doors, the bottom end of the side architraves are cut square first. The top ends are cut mitre with the aid of a mitre box. Mitre means the timber is cut at an angle of 45 degrees. Allow a 3 mm quirk between architrave and jamb. When the architrave fits tight, nail it.



Figure

b) Skirting: - Skirtings are mitre jointed at the corners and butt or mitre jointed along their length.

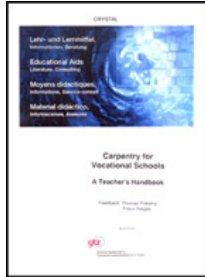


Figure

c) Cornerstrips: - At corners the cornerstrips are mitre jointed and along their length they can be mitre or butt jointed.



[Home](#) > [ar](#).[cn](#).[de](#).[en](#).[es](#).[fr](#).[id](#).[it](#).[ph](#).[po](#).[ru](#).[sw](#)



Carpentry for Vocational Schools - A Teacher's handbook (GTZ, 252 p.)

22. PAINTING

 **(introduction...)**

 **22.1. Types of paint**

 **22.2. Finishes**

 **22.3. Colours**

 **22.4. Methods of applications**

 **22.5. Tools and materials**

 **22.6. Preparations**

 **22.7. Painting**

 **22.8. How to ensure a perfect finish**

 **22.9. Cleaning up**

Carpentry for Vocational Schools - A Teacher's handbook (GTZ, 252 p.)

22. PAINTING

TOPIC: 22. PAINTING

INTRODUCTION: This topic teaches students why painting is necessary; different types of paints; various types of finishes; choosing right colours; different methods

paint can be applied; tools and other materials; how a surface is prepared for painting; the process of painting; points to consider in order to get a perfect finish and cleaning of painting equipments.

OBJECTIVES:

22.1. To know the reasons why surfaces have to be painted and to be able to define the terms: waterbased paints and oilbased paints.

22.2. To distinguish between the different finishes and describe them.

22.3. To chose the right colour and to be able to order paints in a clear specification.

22.4. To know the different methods paint can be applied and to be able to use them correctly.

22.5. To name other tools used when doing paint work and to state their uses.

22.6. To be able to prepare a surface by punching nails, puttying holes and sanding the surface smooth.

22.7., 22.8. To be able to surface correctly and produce a perfect finish.

22.9. To clean equipment and working area of paint.

METHOD: This topic is best taught by demonstrating It on a paint project. But as such projects are not always available try to give as much information and hints as possible in the classroom and prepare all paint equipment and different paints and

varnishes for the lesson to achieve the best teaching results

Students copy all informations from the blackboard in their trade theory book.

NOTE: At the end of this section three worksheets are prepared to reinforce this topic. Worksheets are corrected and assessed later.

There are two reasons for painting timber - to protect it and to enhance its appearance. Many types of paint are available from different manufactures - Dulux, Taubmans etc. Any colour can be obtained.

22.1. Types of paint

a) Waterbased paints: - This paint has water as its base. That means that water makes the paint fluid. When applied, in the process of drying, the water evaporates and only the colour with the other chemicals remains on the surface which is painted.

It is easy to use and handle and equipment is easily cleaned while paint is still wet.

Waterbased paints are also called "Acrylic Paints".

b) Oilbased paints: - This paint has turpentine as base. These "Alkyd Paints" need more care in use and handling but the finish is generally harder than acrylic paints.

In this group we can include wood stain, varnishes, paints etc.

NOTE: For best results select the same type of undercoat and topcoat!

22.2. Finishes

Most topcoat paints and varnishes are available in different degrees of "SHEEN" (light reflection)

a) Matt or Flat: - No shine at all.

b) Semi-gloss or Satin: - Gives a more reflective surface.

c) Full-gloss or High-gloss: - Gives a shiny surface. An advantage is that the surface is easy to keep clean.

22.3. Colours

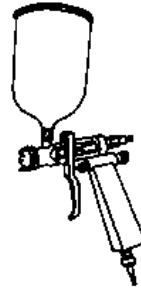
There are ready mixed paints available in popular colours. Most dealers have mixing systems where paints can be mixed according to colour charts. These charts are used to identify colours by name or code-numbers. When using the colours for a building you must choose a balanced range of colours. Too many colours makes it expensive (too many left overs). Too few colours makes it boring to look at. Avoid large areas of dark colours in small rooms.

When ordering paint, you must specify the following:

- a) Manufacturer - eg. Taubmans
- b) Type of paint - eg. Waterbased
- c) Sheen - eg. Satin
- d) Colour - eg. Sky blue
- e) Size of container - eg. 4 litres
- f) Quantity - eg. 6 Tins

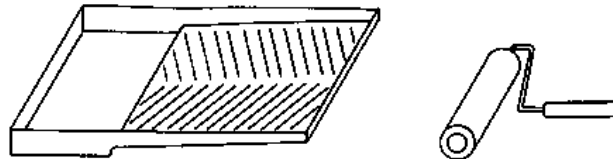
22.4. Methods of applications

a) Spraying: - This gives the best result, but it is difficult to do on building site. Therefore it is best suited for use in spray rooms. Compressed air or electric systems are used.



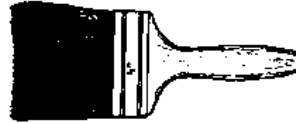
Figure

b) Roller: - This gives a very attractive surface and it is a very fast and efficient method of applying paint on large surfaces (walls, ceilings). Rollers are available in different sizes and a special tray is used for the paint.



Figure

c) Brush: - For all painting where spraying and rolling is not possible. Brushes are available in different sizes from 12 mm up to 150 mm and in various qualities. Always use a brush which does not lose its bristles.



Figure

22.5. Tools and materials

Many tools and materials exist to make the work easy and give good results. They include:

a) Putty knives:



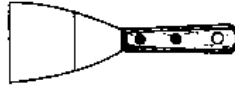
Figure

b) Sanding blocks:



Figure

c) Scrapers:



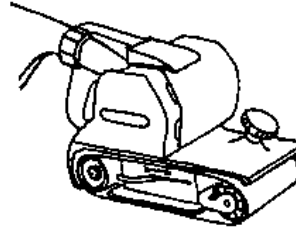
Figure

d) Sandpaper:



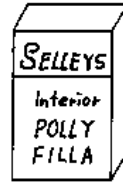
Figure

e) Sanding machines:



Figure

f) Fillers, Putties:



Figure

22.6. Preparations

a) NEW SURFACES: It is very important that the work to be painted or varnished is well prepared. No amount of paint can cover up poorly prepared surface.

The first step is to remove cutter marks from timber and even the surface roughly with a plane or heavy sander.

Next, all gaps and nailholes are filled with an appropriate filler. Polly-filla is available for internal and external use and plastic wood with the colour of the timber for varnished surfaces. When the filler is dry it is sanded (except elastic sealants) flush with the work and sharp edges are broken. If a lot of sanding is needed, start with a coarse grit sandpaper and finish with a fine one.

"SAND ONLY ALONG THE GRAIN OF TIMBER TO BE VARNISHED"

Finally all dust is removed.

b) PREVIOUSLY PAINTED SURFACES: If the old paint is damaged or cracked, it is best to remove it completely by scraping or sanding.

If the old paint is ok, it should be cleaned to remove all grease and dirt. It may be necessary to sand it with a fine grit sandpaper. Where necessary gaps must be filled and sanded. Finally all dust is removed.

22.7. Painting

a) Priming: - First coat to be applied to seal the pores of the timber and prevent following coats to be absorbed. When dry, this coat is sanded to remove raised grains and dust which have settled in the wet paint.

b) Undercoat: - The second coat is the special undercoat which helps to cover the grains. The undercoat, which is normally white, should be tinted when a dark topcoat is applied. The actual topcoat can be used for this. Sand when dry.

c) Topcoat: - One coat of the topcoat is applied to give the final finish and colour. If two coats are applied, sanding in between is necessary.

d) Varnishing: - Varnish is applied in two coats. No undercoat is applied. Sanding is done in between. Usually varnish is applied with a brush. On larger surfaces you can use a roller, but only on semi-gloss or flat varnish. Never on high-gloss varnish!

NOTE: Read instructions on tin before starting.

22.8. How to ensure a perfect finish

a) Make sure preparations are in order.

b) Avoid dust. After sweeping and dusting, you must wait until the dust in the air settles before painting, especially with the last topcoat.

- c) Start with the upper surface (ceiling, barge etc..) and work your way down.**
- d) Finish a small area at the time, working the paint in all directions but finish in "one" direction. Whether you use brush or roller start high and work down.**
- e) Use a brush in corners etc. before rolling.**
- f) Work quickly (not hastily) to ensure invisible overlaps. Use joints, corners etc. for work stoppages.**
- g) Do not paint while other work is being carried out in the same room. The fresh paint might be spoiled.**
- h) Protect sinks, shower tray, cistern, taps, bench tops etc. from droplets of paint with paper or plastic.**
- i) Remove cupboard and doorhandles and knobs before painting starts. Replace when last topcoat is dry.**
- j) Prevent deep marks on floor by placing paint tins, turps, putty etc. on a sheet of plastic or paper.**

22.9. Cleaning up

Keep tools (brushes, roller) clean. Tools used with acrylic paint are cleaned in water before paint dries.

If they have been used in alkyd paint, clean them up in turps (kerosene). Remove as much paint as possible from your tools before cleaning.

THE IMPRESSION OF A BUILDING IS ONLY AS GOOD AS THE PAINTWORK.



[Home](#) > [ar.cn.de.en.es.fr.id.it.ph.po.ru.sw](#)



Carpentry for Vocational Schools - A Teacher's handbook (GTZ, 252 p.)

23. STAIRS

 **(introduction...)**

 **23.1. Technical terms of a stair**

 **23.2. Parts of a stair**

 **23.3. Calculating the number and size of steps**

 **23.4. Calculating the width of the stringers**

 **23.5. Marking out stringers**

 **23.6. Marking out top and bottom end of stringers**

 **23.7. Joining and assembling stairs**

 **23.8. Fixing stairs**

 **23.9. External stairs**

 **23.10. Concrete stairs**

Carpentry for Vocational Schools - A Teacher's handbook (GTZ, 252 p.)

23. STAIRS

TOPIC: 23. STAIRS

INTRODUCTION: This topic teaches students the technical terms of a stair, how to calculate the number of steps in a stair, the procedure of marking, cutting and assembling a stair, fixing stairs in a stairway and other types of stairs.

OBJECTIVES:

23.1. Students should be able to name all

23.2. parts of a stair with their technical terms.

23.3. Students should be able to calculate the number and sizes of steps.

23.4., 23.5., 23.6. Students should be able to calculate the width of the stringers, and to mark them out correctly.

23.7. Students should know how stringers and steps are joined and assembled correctly.

23.8. Students must be able to fix stairs properly.

23.9. Students should be able to explain why external must be different from internal stairs and the procedure for making external stairs.

METHOD: Stairs are quite difficult to make and you cannot teach it clearly without actually making the real tiling.

It is advised to wait with this topic until there is an opportunity to demonstrate it by making a real stair.

Otherwise only the terms for the parts of a stair and the way to find the number and size of steps can be taught in the classroom.

NOTE: At the end of this lesson prepare a worksheet for students to complete as homework.

In general, stairways are usually a special section of the carpentry trade. Simple stairs are prepared on the job by a carpenter and these include verandah steps, external and internal stairs of minor importance.

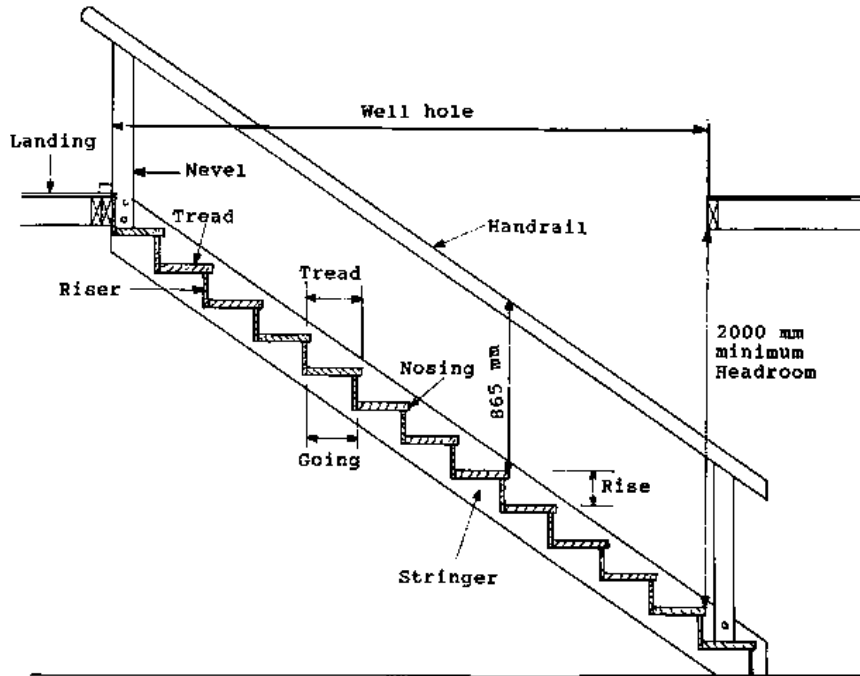
The simplest form of stair is that consisting of only one flight, but this must be designed in the correct proportions for easy travel.

23.1. Technical terms of a stair

- a) Stringer: - The inclined sides of the stair carrying the steps.**
- b) Riser: - The vertical timber which closes the space between two steps.**
- c) Rise: - It is the vertical distance between the top of the one tread and the top of the tread immediately above it. Usually 175 mm.**
- d) Tread: - The board forming the top-surface upon which the foot is placed.**
- e) Go or Going: - The horizontal distance between the face of one riser and the face of the next. Usually 250 mm.**
- f) Nosing: - The rounded edge of the tread projecting over the riser. Usually 20 mm.**

- g) Landing:** - The floor at the beginning or the end of a stair flight and the intermediate floor between two flights.
- h) Well or Well-hole:** - The space in the centre of a staircase between the outer stringers of the flight.
- i) Flight:** - A complete set of stairs reaching from floor to floor or from floor to a landing.
- j) Newel:** - An upright post at each end of a flight of stairs to carry the handrails and sometimes also the stringers.
- k) Handrail:** - The support for the hands at the sides of the stair.

23.2. Parts of a stair



Figure

TIMBER SIZES:

Stringers: 200 mm - 300 mm deep, 40 mm - 50 mm thick.

Risers: 19 mm thick minimum.

Treads: 35 mm - 50 mm thick depending on tread length.

Nevel: 100 mm x 100 mm

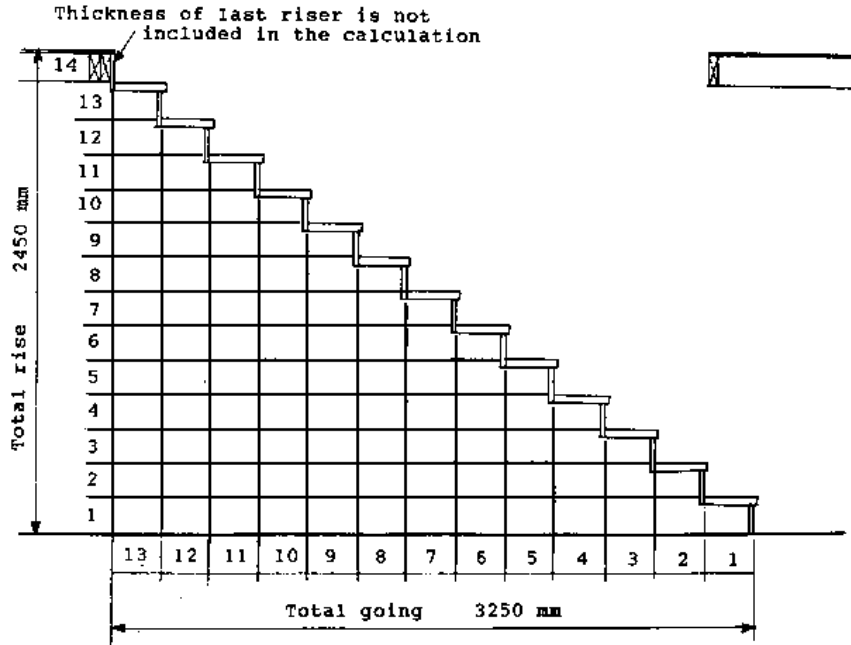
Handrail: 100 mm x 75 mm

23.3. Calculating the number and size of steps

You are advised to make the calculation for the stairs on the building site or with a proper drawing in a scale of 1 : 10 or 1 : 20 in order to make sure the stairs will fit correctly.

The HEIGHT of the riser is calculated by dividing the floor to floor height into a suitable number of risers each being approximately 175 mm.

The GOING is calculated by dividing the total going into a suitable number of treads each going being approximately 250 mm.



Figure

Total Going = 3250 : 13 treads = 250 mm tread

Total Rise = 2450 : 14 risers = 175 mm riser

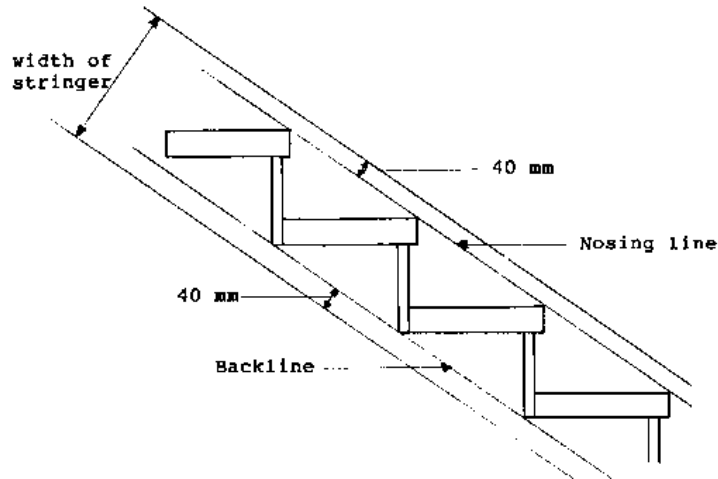
When more space for the going is available, the go can be made up to 300 mm.

23.4. Calculating the width of the stringers

When drawn in all risers and treads with the 20 mm nosing in the plan, draw a line along the nosing and along the back-corners of the steps.

Then measure the width between the nosing-line and the back-line and add on both sides towards the top-edge and the bottom-edge of the stringer 40 mm.

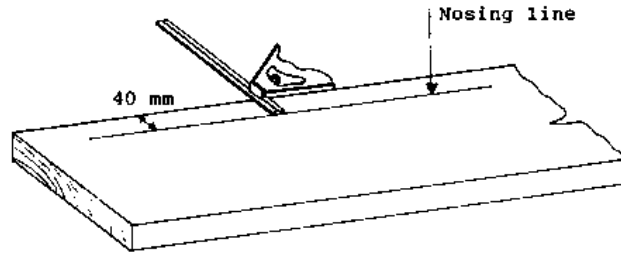
This measurement is the correct width of the stringer.



Figure

23.5. Marking out stringers

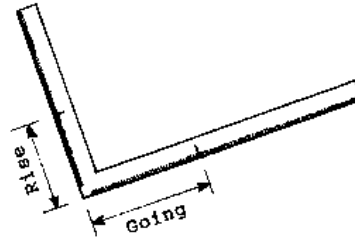
a) Gauging the "nosing line": - The nosing line is gauged 40 mm below the stringer-top with a combination square.



Figure

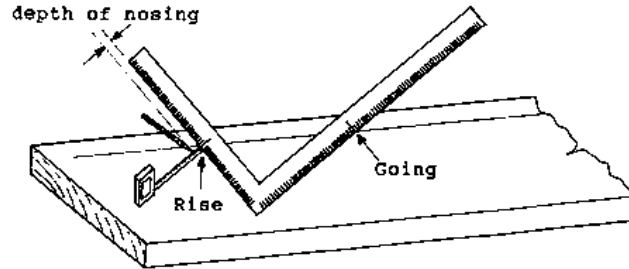
b) Gauging the "setting out line":

- On a steel square, you mark the depth of the going on the blade and the height of the rise on the tongue.



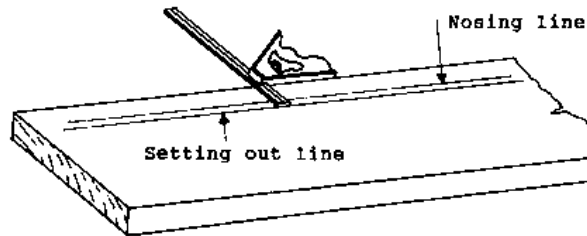
Figure

- The steel square is placed with the rise and the going position on the nosing line. Then measure the depth of the nosing in a right angle from the nosing line and mark it.



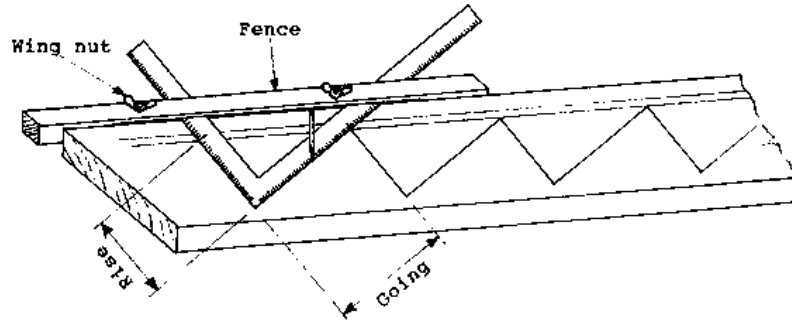
Figure

- Also the setting out line is gauged with a combination square along the stringer.



Figure

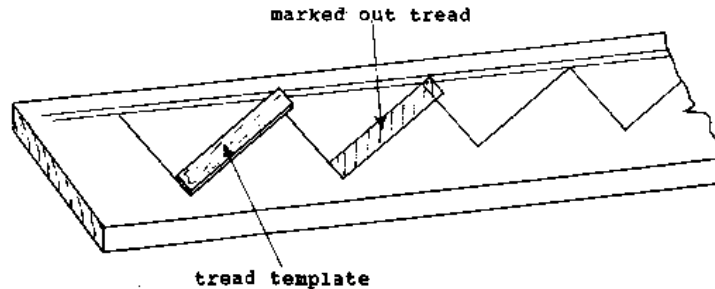
c) Marking out the "face-lines" of tread and riser: - A fence is now attached to the steel square. The riser height and the tread depth-marks on the square must be placed on the setting out line. The fence enables tread and riser lines to be repeated accurately. The face-lines of tread and riser are marked out by sliding the square along the stringer.



Figure

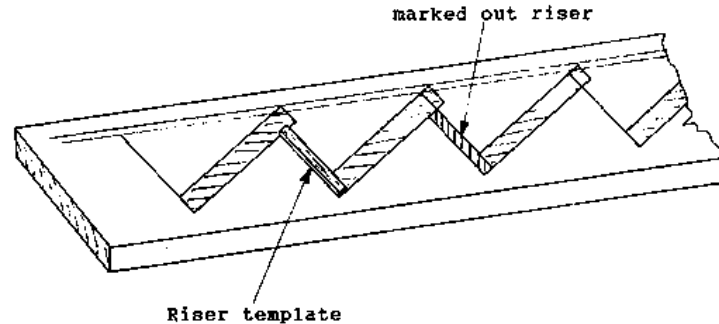
d) Marking out the thickness of tread and riser:

- This is done with templates made of plywood with the exact thickness and width of riser and tread.
- The tread-template is held below the face-line of the tread with the corner meeting the nosing line.



Figure

- The riser-template is held inside the face line of the riser meeting the bottom line of the tread.

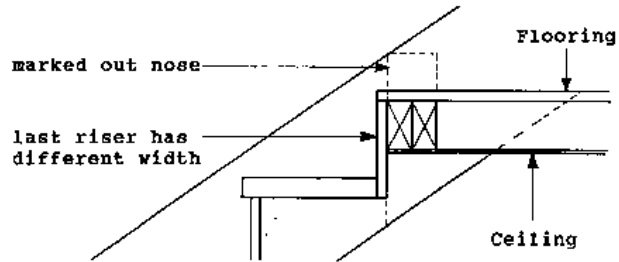
**Figure****23.6. Marking out top and bottom end of stringers**

Stringers must be designed properly in order to give the stair a strong connection to the top and bottom floor.

a) Top-end of stringers:

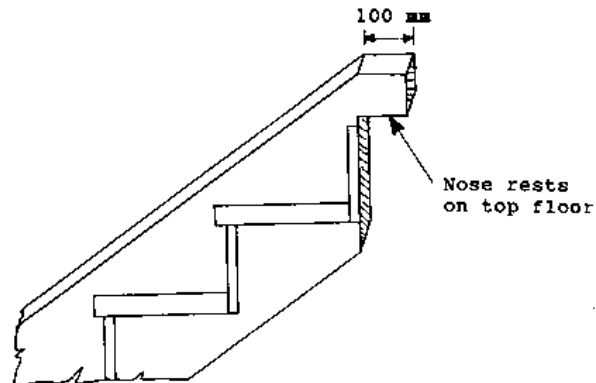
- The last riser must be measured separately, because of the flooring boards covering it. Having marked the last riser, extend the back line to the top and the bottom of the stringer. The bottom of the stringer is cut out on that line up to the floor level. The corner where the line meets the top of the stringer is marked out horizontally. Mark it with a length of 100 mm and plumb it down

vertically. Then cut out the nose so it can rest on the floor.



Figure

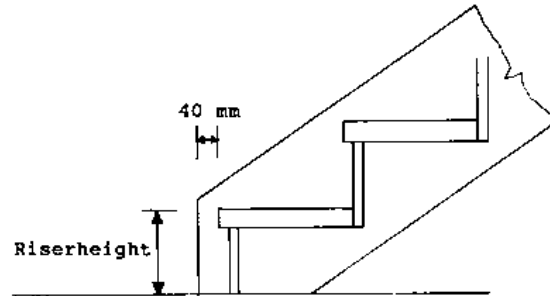
- The completed top-end of the stringer.



Figure

b) Bottom-end of stringer: - Make a plumb cut 40 mm in front of the nosing and

square off the heel of the stringer to rest on floor.

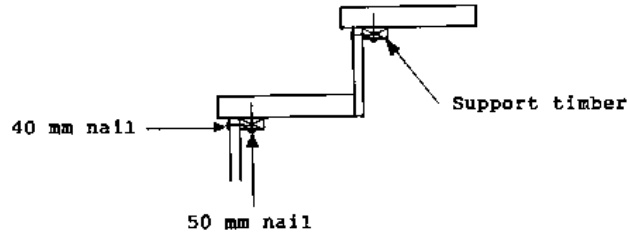


Figure

23.7. Joining and assembling stairs

For interior stairs, treads and risers are usually joined to the stringers by housing joints which are chiselled 12 mm into the stringer. This job has to be done with accuracy in order to achieve a good result and prevent the steps from creaking.

On the bottom of the tread you have to glue and nail timber battens in the size of 50 mm x 20 mm to support the riser. When assembling, join the riser to the tread by nailing the riser to the support timber.

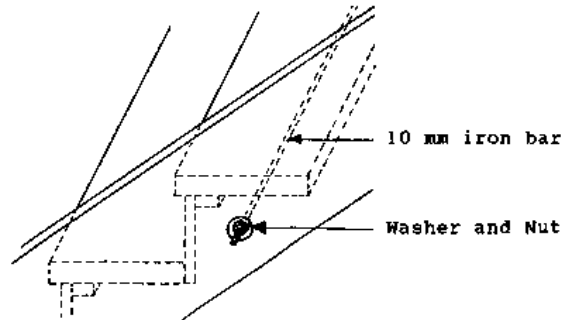


Figure

Where stringers are not restrained by walls, the stringers must be bolted together with long iron bars, 10 mm in diameter and a thread cut on both ends. These iron bars must be placed at least two to three times in a stair.

Drill 10 mm holes in the stringers directly underneath a tread. When assembled, all treads and risers with the stringers, place the bars into the holes, put washer and tighten the stringers together with two spanners.

Overlength of bars can be cut and covered with a piece of timber to improve appearance.



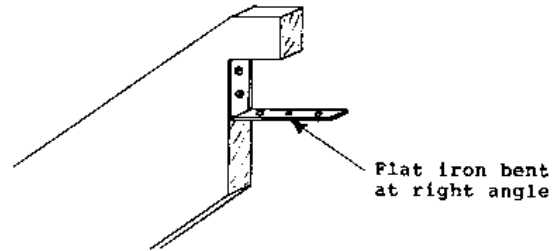
Figure

23.8. Fixing stairs

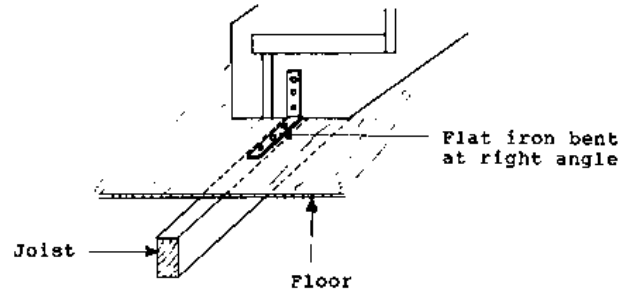
a) Top-end: - On the plumb-cut, you screw a flat iron (40 mm x 5 mm) which is bent at a right angle to fit on the underside of the top-floor joist.

The thickness of the flat iron is sunk into the stringer and joist.

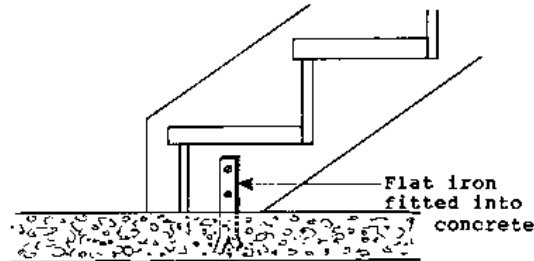
First, the angle iron is screwed to the stringer then, when the stair is placed into the correct position, screw the iron to the joist.

**Figure****b) Bottom-end:**

- On foundations where you have joists, make sure you have a joist where the stringer is sitting. Also here you use a flat iron bent at a right angle, which is screwed directly under the last tread on the inside of the stringer. Make sure the iron, which you screw later to the floor, is in line with the joist.

**Figure**

- On concrete slabs, a flat iron is fitted into the fresh concrete to hold the stringer. Put it in such a way that the iron can be screwed on to the inside or sometimes, to the outside of the stringer.



Figure

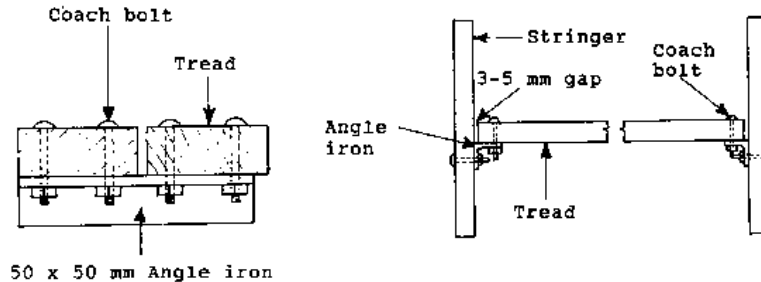
23.9. External stairs

Stairs which are exposed to rain and sun are usually open.

That means that they have no riser, so that the rainwater can run off easily.

Treads are also fixed differently on outside stairs.

An angle-iron is bolted to the riser where the tread rests. Often treads are made in two pieces to avoid water standing on the timber.



Figure

Leave 3 mm - 5 mm space between tread and stringer to prevent the timber from rotting when water enters between the timbers.

23.10. Concrete stairs

Look in chapter 4.3.



[Home](#) > [ar](#).[cn](#).[de](#).[en](#).[es](#).[fr](#).[id](#).[it](#).[ph](#).[po](#).[ru](#).[sw](#)

Carpentry for Vocational Schools - A Teacher's handbook (GTZ, 252 p.)

➔ **24. HARDWARE**

(introduction...)

24.1. Locks

24.2. Hinges



Carpentry for Vocational Schools - A Teacher's handbook (GTZ, 252 p.)

24. HARDWARE

TOPIC: 24. HARDWARE

INTRODUCTION: This topic teaches students different types of locks and hinges used on doors.

OBJECTIVES: Students should be able to identify different locks and hinges and choose the right lock and hinge for the doors.

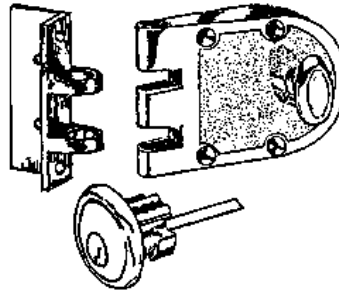
METHOD: Prepare different locks and hinges, display them in the classroom and explain the uses and characteristics of each lock and hinge.

NOTE: Prepare photocopies of locks and hinges and distribute them to students.

24.1. Locks

a) "Lockwood" 203 Deadbolt operation - Key outside, knob inside.

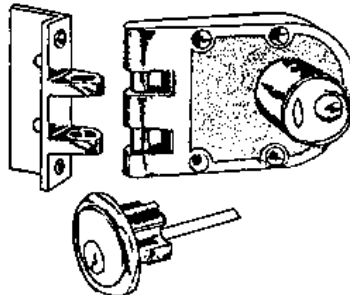
Use: For external doors.



Figure

b) "Lockwood" 205 Deadlock operation - Key inside and outside.

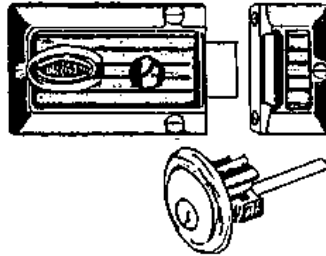
Use: For external doors.



Figure

c) "Lockwood" 201 Nightlatch operation - Key outside and knob inside.

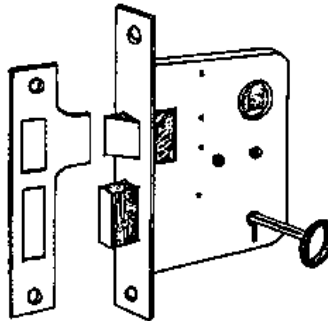
Use: For external doors.



Figure

d) "Lockwood" 540 mortice lock

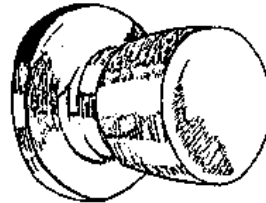
Use: For internal and external doors.



Figure

e) "Lockwood" 1105 Thunderbird, round knob and rose use with mortice lock.

Use: With lock- external use, without lock internal use.



Figure

f) Padlock:



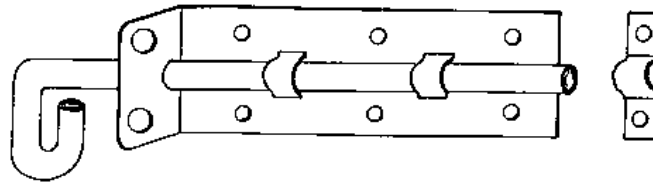
Figure

g) Hasp and staple:



Figure

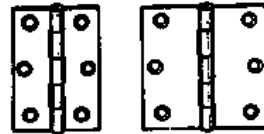
h) Padbolt:



Figure

24.2. Hinges

a) Butt hinges:



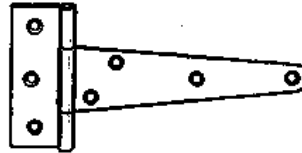
Figure

b) Strap hinges:



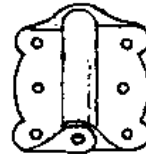
Figure

c) Tee hinges:



Figure

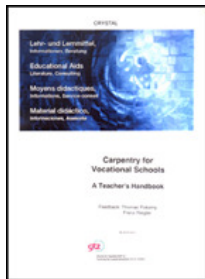
d) Screen door hinges:



Figure



[Home](#) > [ar](#).[cn](#).[de](#).[en](#).[es](#).[fr](#).[id](#).[it](#).[ph](#).[po](#).[ru](#).[sw](#)



 **Carpentry for Vocational Schools - A Teacher's handbook (GTZ, 252 p.)**

  **25. WATERTANKS**

 **(introduction...)**

 **25.1. Sizes of watertanks**

 **25.2. Watertank foundations**

 **25.3. Ferrocement tanks**



25.4. Maintenance and treatment of watertanks

Carpentry for Vocational Schools - A Teacher's handbook (GTZ, 252 p.)

25. WATERTANKS

TOPIC: 25. WATERTANKS

INTRODUCTION: This topic teaches students how to chose the right size of watertanks, how foundations for watertanks are made, how to make a ferrocement watertank and how to maintain and treat water-tanks.

OBJECTIVES:

25.1. To know the different sizes of water-tanks, to choose the proper size of the tank and the proper type of foundation for it.

25.2. To know how to make a correct foundation for a watertank on roofs, stumps or concrete.

25.3. To be able to describe the procedure for making a ferrocement watertank.

25.4. To know how to treat and maintain water-tanks properly.

METHOD: Making ferrocement tanks is difficult for the unexperienced.

To provide students with the necessary knowledge to make such tanks it is certainly not enough to have lessons in class only.

Therefore it is worthwhile to take the time to make a ferrocement tank as a school project.

NOTE: At the end of this lesson prepare at least two worksheets for students to complete as homework.

They are collected and corrected and assessed later.

In rural areas, where watersupply systems are not possible, watertanks are installed to provide clean water insuring good health life and to store water in dry seasons.

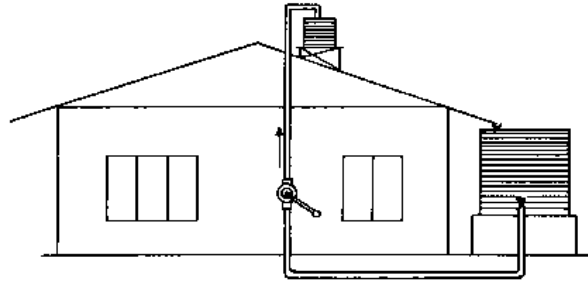
25.1. Sizes of watertanks

Common watertanks are made of corrugated iron and available in sizes of 80 gallon (360 litres), 660 gallon (3000 litres) 1000 gallon (4500 litres) and 2000 gallon (9000 litres).

The size of the tank depends much on the size of the roof, the number of people using water and the space to put the tanks. If a very large roof is available, try to put as many tanks as possible to avoid a big loss of water. On small roofs, try to put large a tank, because it takes a long time to fill it up and you have to make sure the tank is filled in the wet season.

To achieve sufficient water pressure in the house, especially when installing a shower, an "overhead tank" has to be put on the roof of the house. Also in connection with a hot-water solar system, an overhead tank is needed. These tanks are usually 80 gallons and are connected by a pump to the ground tanks. There are electric pumps available, but because of non existing powersupply in rural areas, a manual

hand pump is more appropriate.



Figure

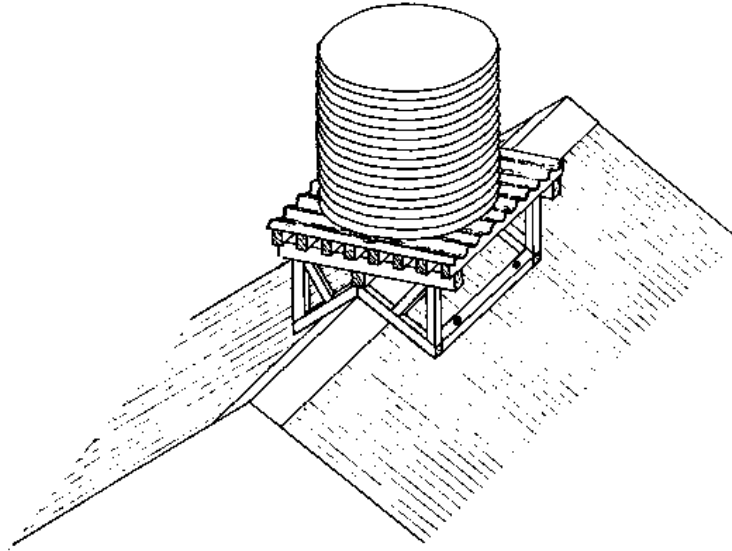
25.2. Watertank foundations

Tanks must be placed on a very solid, even and levelled surface in order to prevent them from cracking caused by uneven foundations.

a) Foundations for overhead tanks:

- An iron or timber frame is made to fit exactly to the slope or the ridge of the house. The frame must be braced correctly. Joists are laid and covered across with roofing iron. Roofing iron has the advantage of keeping the bottom of the tank dry because the rainwater will run off in the valleys.

Make the roofing iron longer than the frame to keep the construction dry. The whole frame is secured by nailing or screwing down to a purlin.

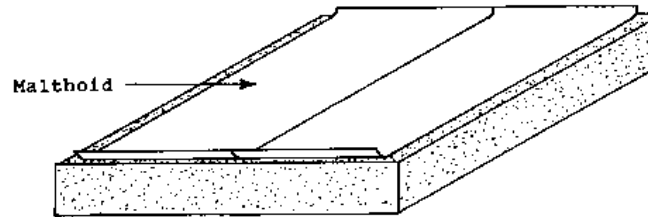


Figure

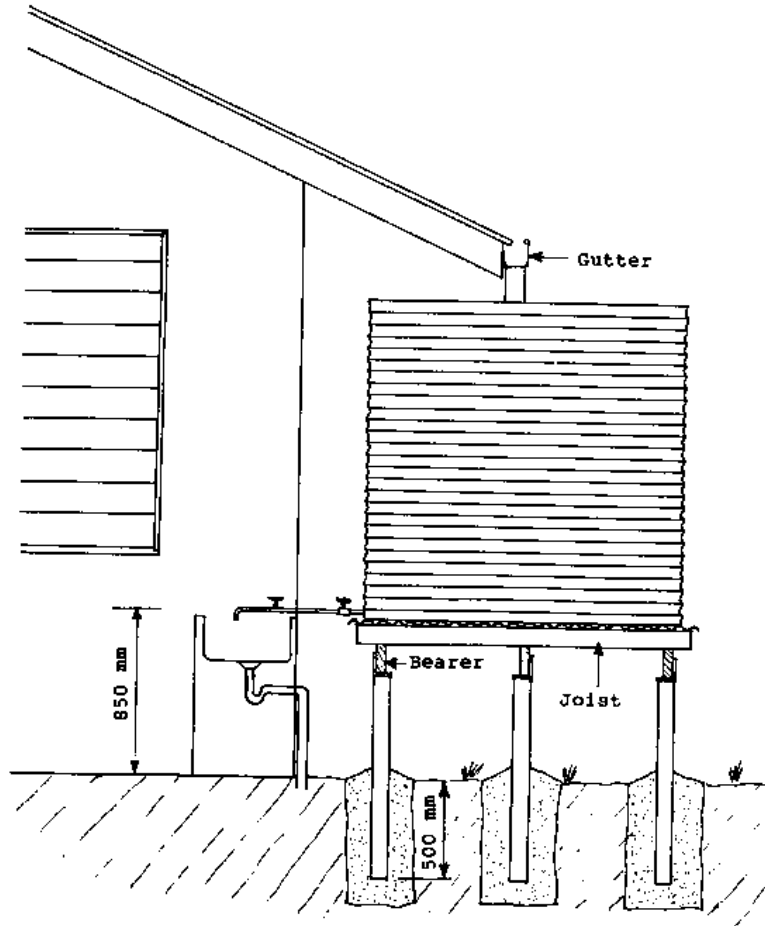
b) Concrete foundation: - Concrete foundations are required where the tank is near ground level and usually associated with a pump, because the outlet will be too low to give pressure to all tapes in the house.

The foundation is a simple concrete slab with an outside foundation going into the ground about 300 mm.

The surface must be completely leveled and smoothed. When dry, put a layer of "Malthoid" (Bitumen foil) to prevent the bottom of the tank from being in immediate

contact with the concrete.**Figure****c) Stump foundations:**

- **When tanks need to be elevated in order to get sufficient water pressure in your kitchen or toilet, you can make it with a stump foundation. Steel, wooden or concrete stumps can be used.**
- **You have to be careful that you set the stumps at such a height, that there is later enough space left to fit the tank between the gutter and the top of the foundation.**
- **Stumps must be going at least 500 mm into solid ground and are surrounded firmly by concrete.**
- **Bearers must be 6"x2" (150 mm x 50 mm) and joists 4"x2" (100 mm x 50 mm) being placed upright ontop of the bearers with a spacing of about 150 mm. Roofing iron is nailed across. It must not be joined, to prevent water from entering to the joists and rotting them.**



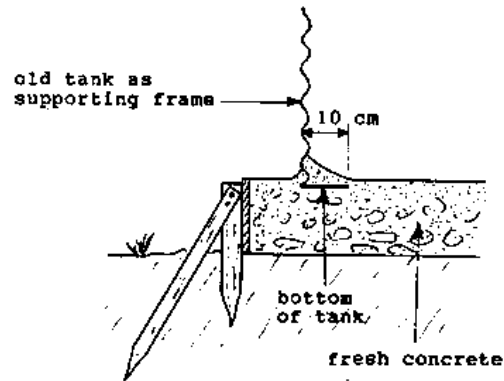
Figure**25.3. Ferrocement tanks**

An old corrugated iron tank which has rusted through can be used as the supporting frame for the ferrocement tank.

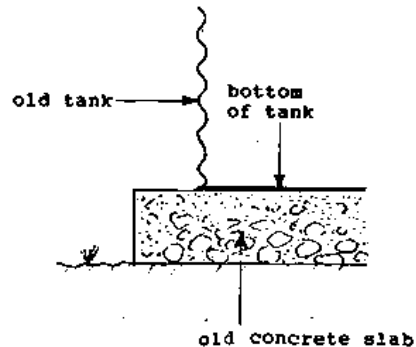
a) Preparation:

- **When making a new concrete slab foundation, take out the lid and cut the bottom of the tank approximately 10 cm away from the wall.**

Set the tank in the fresh concrete and cover the 10 cm bottom iron with fresh concrete.

**Figure**

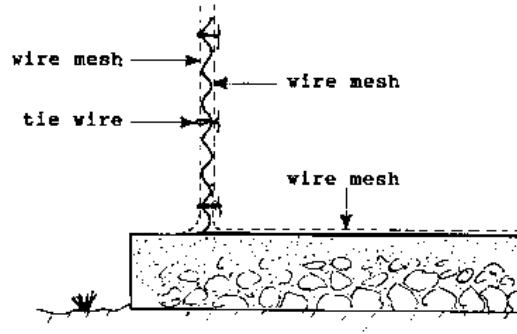
- **When setting the tank on an old concrete slab foundation, take out the lid and clean off the inside of the tank with wire brush and wash out.**



Figure

b) Putting the wire mesh:

- **Where the tank has a new foundation and the slab provides the bottom of the tank, a chicken wire mesh is laid inside and outside on the wall of the tank. For this punch holes all over the tank. The tie wire is passed through these holes to fasten the inner layer of chicken wire to the outside wire.**
- **Where the tank is placed on an old concrete slab , first lay of wire mesh on the bottom of the tank. Let the wire go up the wall about 15 cm and then lay the outside and inside wall and fasten them with the bottom layer.**



Figure

c) Putting the cement mortar:

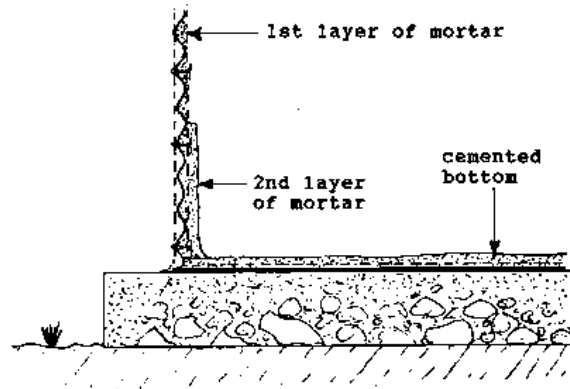
- The cement mortar must be made of fine sand and mixed with cement to a proportion of 2 parts sand to 1 part cement. The cement mortar should not be too wet.
- First, cement the bottom of the tank to a depth of about 50 mm. Check to see if the outlet to the tap is above this level. Let dry for 18 hours.
- The next step is to make a fairly dry mix and spread the mortar behind the wire mesh beginning at the bottom working up the wall.

Make sure all spaces between wall and wire mesh are filled properly.

- On reaching the top of the wall, start again from the bottom and cover the

wire mesh with a second layer of cement mortar, working upwards in the same way.

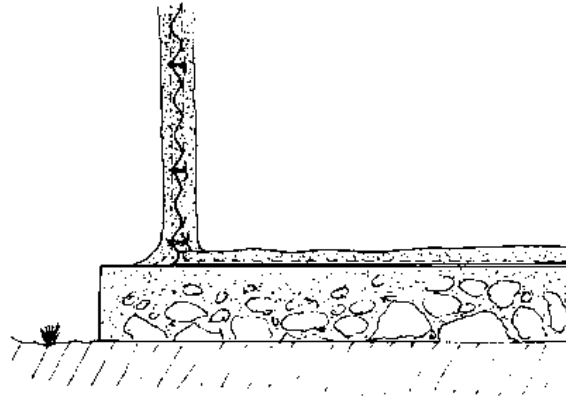
- Use a steel or wooden float to smooth the mortar.



Figure

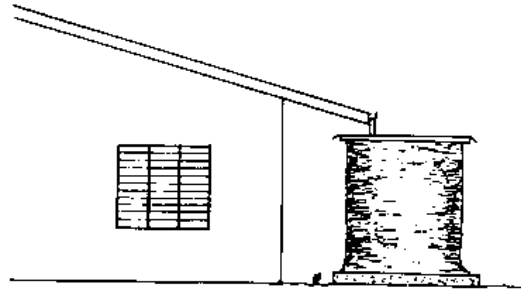
- When the inside is finished continue in the same way on the outside of the tank until the tank is covered and smoothed.

- After the mortar has dried for 24 hours, mix up cement and water in a bucket to form a paste-like cement wash. Use a brush to apply this cement wash on the inside and the outside of the tank in order to close all little holes still remaining in the wall and bottom of the ferrocement tank.



Figure

- **The tank must be allowed to dry slowly. During this time keep it covered and every day water should be splashed over the tank. After two weeks, the tank can be half filled and two weeks later it can be filled to the top.**
- **Now the tank is strong enough to fit the lid. The lid can be made of a timber construction covered with flat iron provided with a hole to fit the strainer to catch the water from the gutter.**
- **Make sure all little spaces between lid and tank are closed with flywire to prevent mosquitoes from breeding inside the tank.**



Figure

25.4. Maintenance and treatment of watertanks

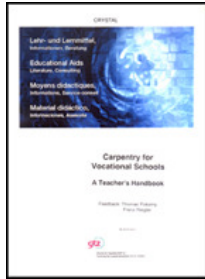
The most important thing to do is clean out the strainer of fallen leaves and other rubbish regularly. Before installing new corrugated watertanks, you can paint the inside with a special silver paint or bitumen based paint, suitable for watertanks, roofs and gutters. When buying paint ask for this paint only. Do not use any other paint because your health may be affected by the chemicals of any other paint.

Tanks should be cleaned inside from time to time. For this, disconnect the tank from the watersupply system and the gutter. Drain the water out and brush it thoroughly with a hard brush and wash out with a water hose.

Where rust spots occur, let the tank dry out completely and repaint it. Let the paint dry for at least one week to make sure the water is not spoiled by the paint.

Join the tank again to gutter and watersupply system.





 **Carpentry for Vocational Schools - A Teacher's handbook (GTZ, 252 p.)**

 **(introduction...)**

 **PREFACE**

 **1. TIMBER**

 **2. SCALES**

 **3. CONCRETE**

 **4. CONCRETE FORMWORK**

 **5. FOOTINGS**

 **6. TOOLS USED ON BUILDINGS**

 **7. FASTENERS**

 **8. FOUNDATION**

 **9. JOINTS**

 **10. BRACING**

 **11. WALLFRAME**

 **12. CEILING**

 **13. ROOFING**










 **14. WINDOWS**

 **15. OUTSIDE CLADDING**

 **16. FLOORING**

 **17. ELECTRICITY**

 **18. PLUMBING**

-  **19. INSIDE CLADDING**
-  **20. DOORS**
-  **21. SKIRTING, ARCHITRAVES, CORNERSTRIPS**
-  **22. PAINTING**
-  **23. STAIRS**
-  **24. HARDWARE**
-  **25. WATERTANKS**
-   **BIBLIOGRAPHY**

BIBLIOGRAPHY

We used some other resources in the production of this book and you can refer to these for more information.

- 1. The Australian Carpenter, by C. Lloyd**
- 2. The Australian Owners Builders Manual, by Allan Staines**
- 3. The Australian Carpenter and Joiner,**

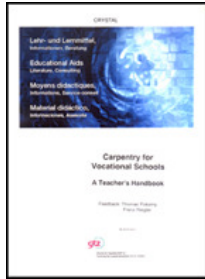
Volume 1, 2, 3, 4.

by E. Peterson, M.A.I.C.S.

Department of Technical Education N.S.W.

Printed by Wirui Press, P.O. Box 107 Wewak, E.S.P., Papua New Guinea





Carpentry for Vocational Schools - A Teacher's handbook (GTZ, 252 p.)

1. TIMBER

(introduction...)

1.1. Growth of a tree

1.2. Timber conversion

1.3. The air-seasoning of timber

1.4. Shrinkage of timber

1.5. Defects in timber

1.6. Commercial size of timber

1.7. Common timber

1.8. Specification of material

Carpentry for Vocational Schools - A Teacher's handbook (GTZ, 252 p.)

1. TIMBER

TOPIC: 1. TIMBER

INTRODUCTION: Before we begin talking about building houses, we think that students should know about where the timber comes from; the environment in which the tree has grown and the functions of a tree while it is still alive.

This topic teaches students how a tree grows, the parts of a tree, how a tree is

converted into timber, the seasoning and shrinkage of timber, timber defects, common timber sizes and the names of timber used in the construction of a house.

OBJECTIVES:

- 1.1. Students should be able to state the names of the parts of a tree and their functions.**
- 1.2. Students should know how a tree can be converted into timber.**
- 1.3. Students must be able to define "seasoning of timber" and know why it is necessary.**
- 1.4. Students should know what happens to timber during the process of drying.**
- 1.5. Students must be able to identify the different defects and their causes.**
- 1.6. Students must know the commercial names and sizes of the timber used for buildings .**
- 1.7. Students should be able to name some common timber from their area and its characteristics.**
- 1.8. Students must be able to name all the technical names of the timber used in a house construction.**

METHODS: In teaching it is widely known that lessons are more effective when they also contain practicals as well as objects shown to students, in order to give them a

better understanding of the subject.

1.1. After writing down the parts of a tree, prepare a cross section of a log and show the different parts and their colours.

1.2. We explain the different ways a log can be converted to timber. When possible organize an excursion to a sawmill and let the manager explain the process.

1.3., 1.4. After introducing this topic on the blackboard, prepare a piece of completely wet timber and let students take measurements. Let them measure it again after a few weeks and check if it has changed in size and shape.

1.5. Prepare some timber with defects as shown in this book and display it in the classroom. Explain to students how some defects can be prevented.

1.6. Prepare some pieces of timber in the sizes shown in the book and display them in the classroom.

1.7. Prepare some samples of common timber used in furniture and building work and describe their characteristics as well as their applications.

1.8. When possible, take the students to a building and show them all the parts of a house and name them.

NOTE: It is advised to go through each single topic first in the classroom and discuss it with the students. Students also should use their Trade Theory book to draw and write down all important things. To make work easier and faster, you can photocopy the drawings from the teachers book, cut them out and glue them in the students

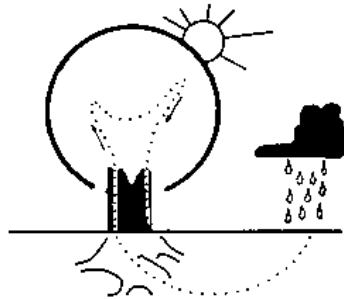
book.

Afterwards prepare a worksheet with questions which students can fill in during their private or nightstudies and be assessed later.

1.1. Growth of a tree

The Leaves contain a green pigment called chlorophyll. It utilises the energy of sunlight to combine carbon dioxide with mineral salts into food called carbohydrate.

The food (carbohydrate) is carried by the inner bark (sap-wood) to all parts of the tree. Trees grow each season by adding a new layer each time onto the old layer. The lines left behind during the seasons growth are called annual or growth rings.



Figure

The tree consists of three main parts: crown, trunk and roots.

a) Crown

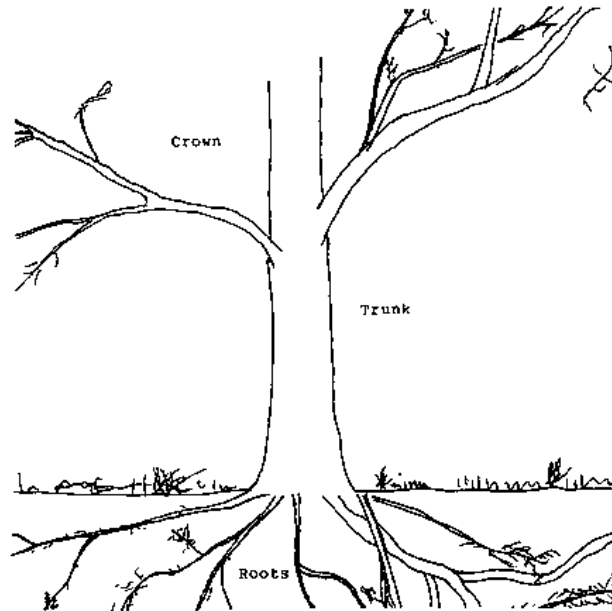
- **holds leaves together**
- **adds height and spreads new growth of twigs**
- **manufactures food for trees**

b) Trunk

- **supports crown**
- **produces timber**
- **helps to transport water to leaves**
- **stores food for trees**

c) Roots

- **anchor**
- **collect water and mineral salt**
- **prevent soil erosion**



Figure

The wood is made up of countless tube-like cells packed closely together and joined end to end.

The parts of a tree, as seen from a cross section.

a) Pith - the original tree sapling

b) Heartwood - inactive part which gives strength to the tree

c) Summer growth - tree stop, growing in dry season (PNG)

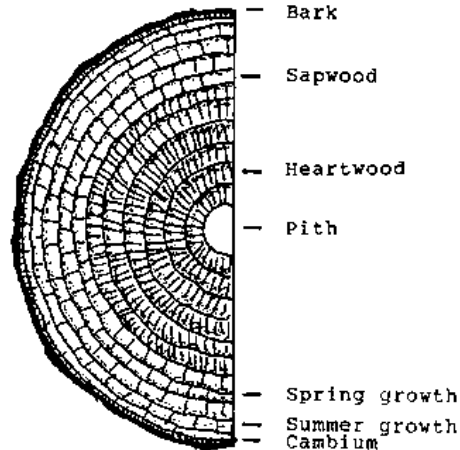
d) Spring growth - tree grows in wet season (PNG)

e) Sapwood - it is less valuable than heartwood, it offers less resistance to decay and attack by fungi and insects.

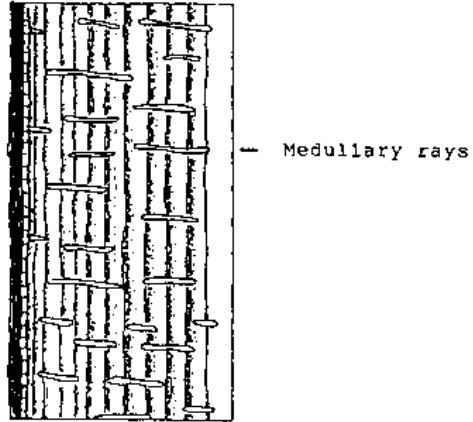
f) Cambium - thin layer of cells which forms new cells towards wood and bark.

g) Bark - protects and covers inner layer called Bast. Bast carries food from leaves to cambium.

h) Medullar rays - store and pass food horizontally



Cross section

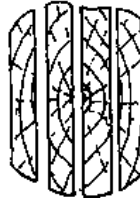


Longitudinal section

1.2. Timber conversion

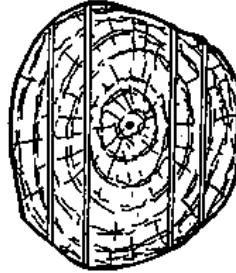


The log goes through the circular saw while still held in one position.



Showing a piece of board from a single pass live sawing.

Single pass live sawing

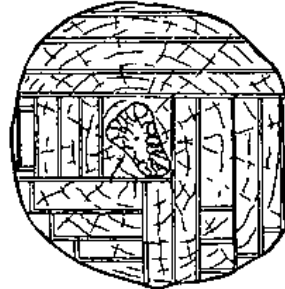


The log passes through the saw in two separate operations.
Firstly - Slicing the outside parts
Secondly - Slicing the middle section.

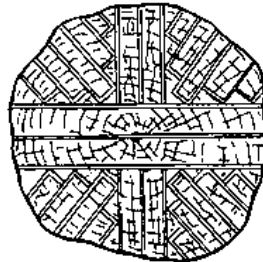


Showing a piece of board from double pass live sawing.

Double pass live sawing



Back sawing (Tangential cut)



Quarter sawing (Radial cut)

1.3. The air-seasoning of timber

The sawn timber has to be stacked for drying until its moisture content goes down to 15 percent.

Drying is by evaporation: the air is able to absorb moisture, and moving air dries more effectively.

An open, well-drained site should be selected, the foundations solidly laid with provision for cross and end ventilation, and at least 450 mm above the ground.

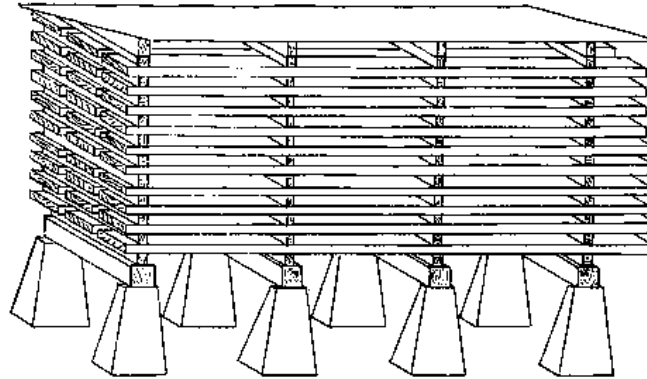
The boards should be stacked 25 or 50 mm apart to form vertical flues.

Each layer of boards is separated by spacing strips set from 600 to 1200 mm apart to enable fresh air to enter from the side. The spacing strips have to be set in a vertical row.

The quality of the lumber depends a lot on how it was stacked for seasoning.

A waterproof covering should be placed over the stack to protect it from sun and weather.

The time taken for air seasoning depends upon several factors, such as type of timber, size of boards, time of the year, site on which the stack is built, and the method of stacking. Roughly it takes about twelve month for each 20 mm timber-thickness.



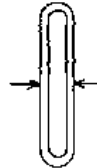
Figure

1.4. Shrinkage of timber

Shrinkage takes place during the process of drying or seasoning of the timber. All timber will shrink, regardless of the type or the method by which it is seasoned. Some timber shrinks more than others.

There are two stages in the drying process of green timber. Firstly the removal of the "free water" from the cell cavities and secondly, the drying of the "combined moisture" from the cell walls. It is during this second stage that timber shrinks; no shrinkage occurs during the removal of the free water.

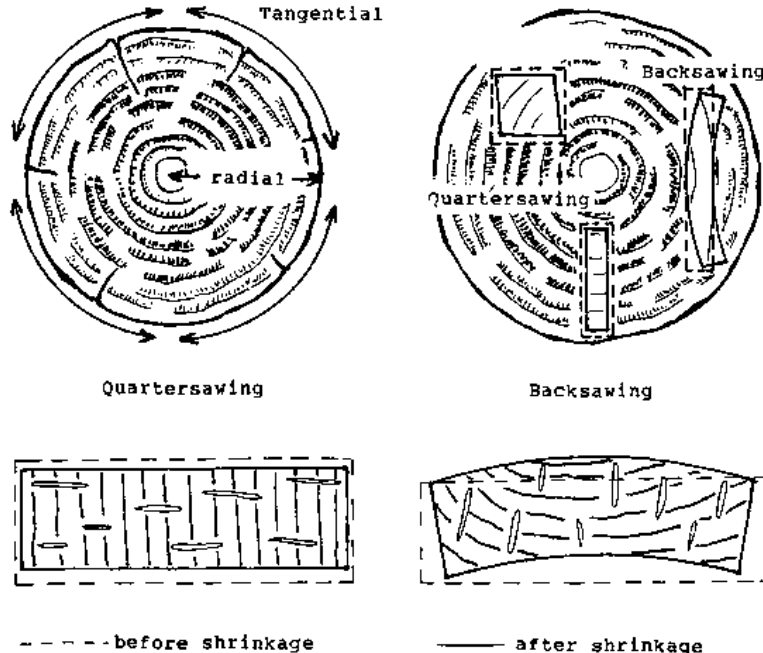
When the moisture is drawn from the cell walls, the cell walls themselves become smaller, consequently the board becomes smaller.

**cell filled****cell cavity dry****cell dry - shrinkage**

The cells do not shrink to any extent in their length, hence there is very little shrinkage in the length of a board when it is dried. Similarly the medullary rays do not shrink very much in their length, and as they run across the timber (in a quarter sawn board) they tend to prevent the layers of growth rings from shrinking towards the centre of the pith. Most shrinkage, therefore takes place in the direction of the growth rings, at right angles to the medullary rays. This is called tangential

shrinkage. Tangential shrinkage is about double radial shrinkage and about hundred times as great as longitudinal shrinkage.

The sapwood, containing more moisture, will shrink more than the heartwood.



Figure

Owing to the fact that the outer surface of a log are in contact with the air they dry more quickly, and therefore shrink before the inner layers of the wood. This cause

splitting or surface cracks. It is therefore advisable to "break down" the log into commercial sizes as soon as possible after felling.

1.5. Defects in timber

Since timber is a natural product, developed through many years of growth in the open air, exposed to continual and varying climate conditions, it is prone to many defects.

Defects cannot be corrected and therefore each individual piece must be inspected before use and judged on its own merits. Defects can be caused during growth, during drying, through insects, through fungi or during subsequent handling or machining, and each should be known, so that imperfect pieces can be detected and rejected.

a) During growth

- Shake is called a partial or complete separation between adjoining layers of wood, due initially to causes other than drying. The three types are Heart shake, Cup shake and Star shake.



Starshake

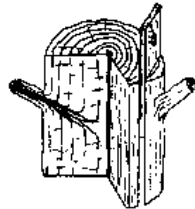


Heartshake

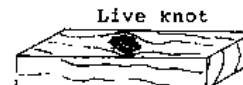


Cupshake

- Knots can be caused by a branch or limb being cut through the process of sawing up the log. Knots are classified in two groups: live knot and dead knot. Live knot is left by a branch when the tree is felled.



Live knot



Live knot

Live knot

- Dead knot is left by branches that have been cut off or broken before felling,

and which cannot be relied on to remain in position in the piece.



Dead knot

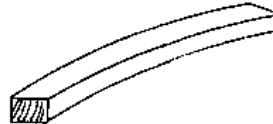
- Gum pocket is a cavity which has contained or contains gum.



Gum pocket

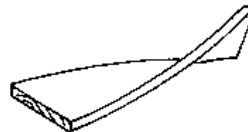
b) During or after drying process

- Bow is a deviation from the flat, the piece being arched.



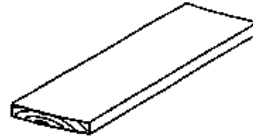
Bow

- Twist is a spiral distortion along the length of a piece of timber.



Twist

- Cup is a curvature across the width of a piece of timber.

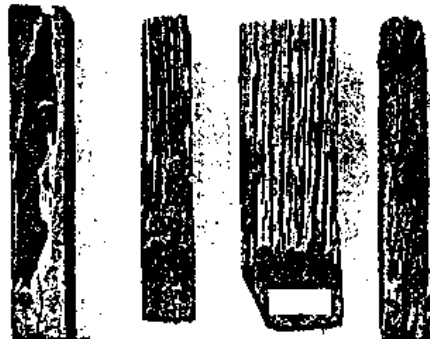


Cup

c) Defects through insects

- Termites or white ants attack timber structures and are a serious problem in Papua New Guinea.

The species that causes the damage live in the ground. Precautions involve treating timber with a preservative or avoiding direct timber contact with the ground.



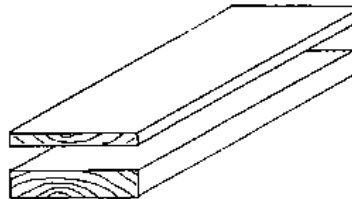
Types of termite damage

Left unchecked termites eat the wood, leaving the outer shell intact. Often their presence is not evident until serious damage has occurred

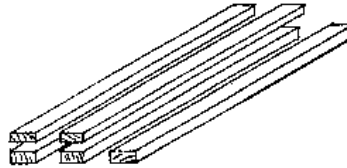
1.6. Commercial size of timber

Common trade names:

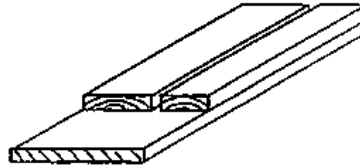
- a) Log - A trunk with branches off.**
- b) Plank - Pieces 38 mm to 100 mm (1½" to 4") thick and 150 mm (6") or over wide.**
- c) Boards - Pieces 10 mm to 38 mm (3/8" to 1½") thick and 75 mm (3") and over wide.**
- d) Battens - Pieces 19 mm to 38 mm (¾" to 1½") thick and from 25 mm to 75 mm (1" to 3") wide.**
- e) Strips - Under 19 mm (¾") thick and up to 75 mm (3") wide.**
- f) Moulding - Shaped timber, can be plank, boards, strips etc...**



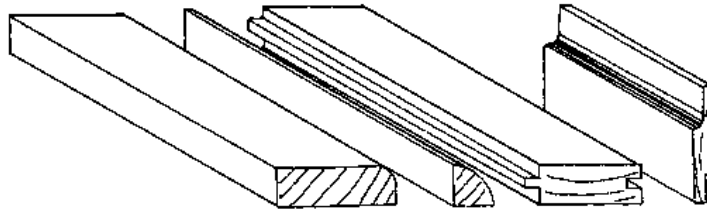
Plank



Battens and Stripes



Boards



Mouldings

Manufacturing terms:

- a) Rough Timber - Timber with sawn surface.**
- b) Dressed Timber - Machine planed timber.**

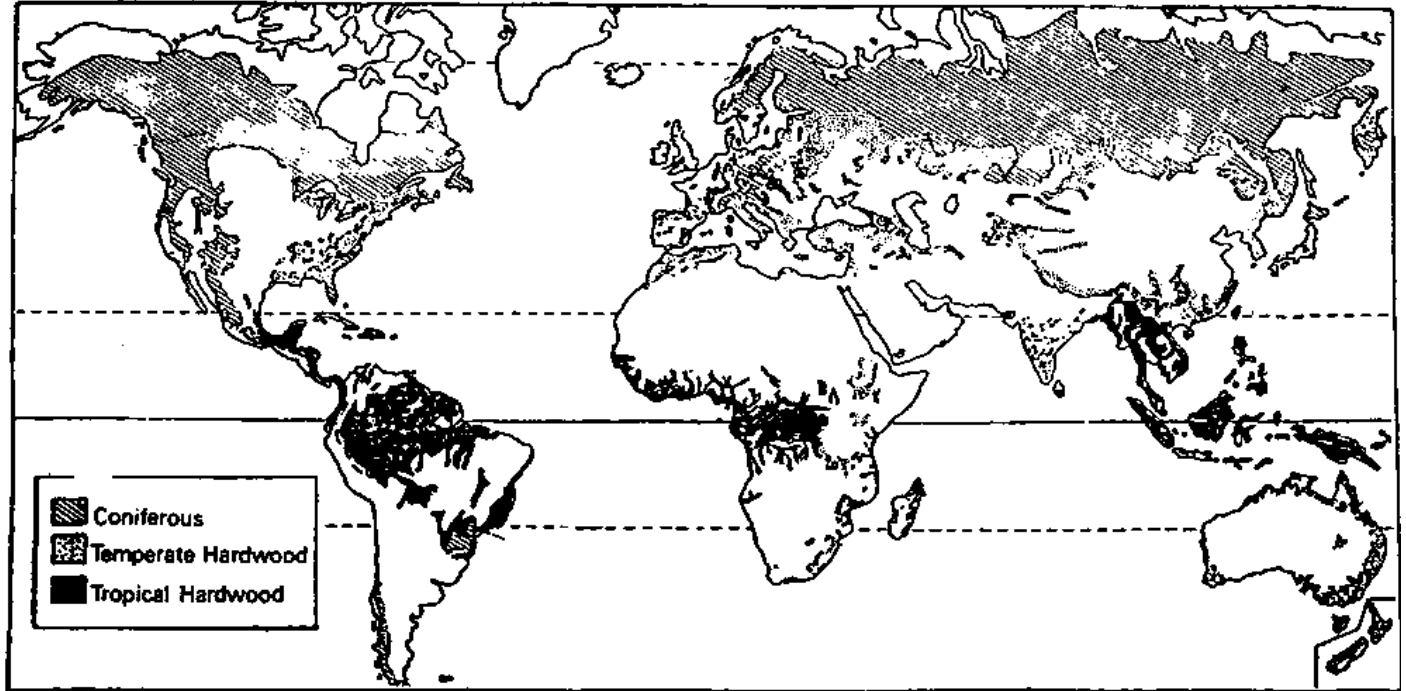
E.g. DIS - Dressed one side

DD (or D2S) - Double dressed or dressed two sides.

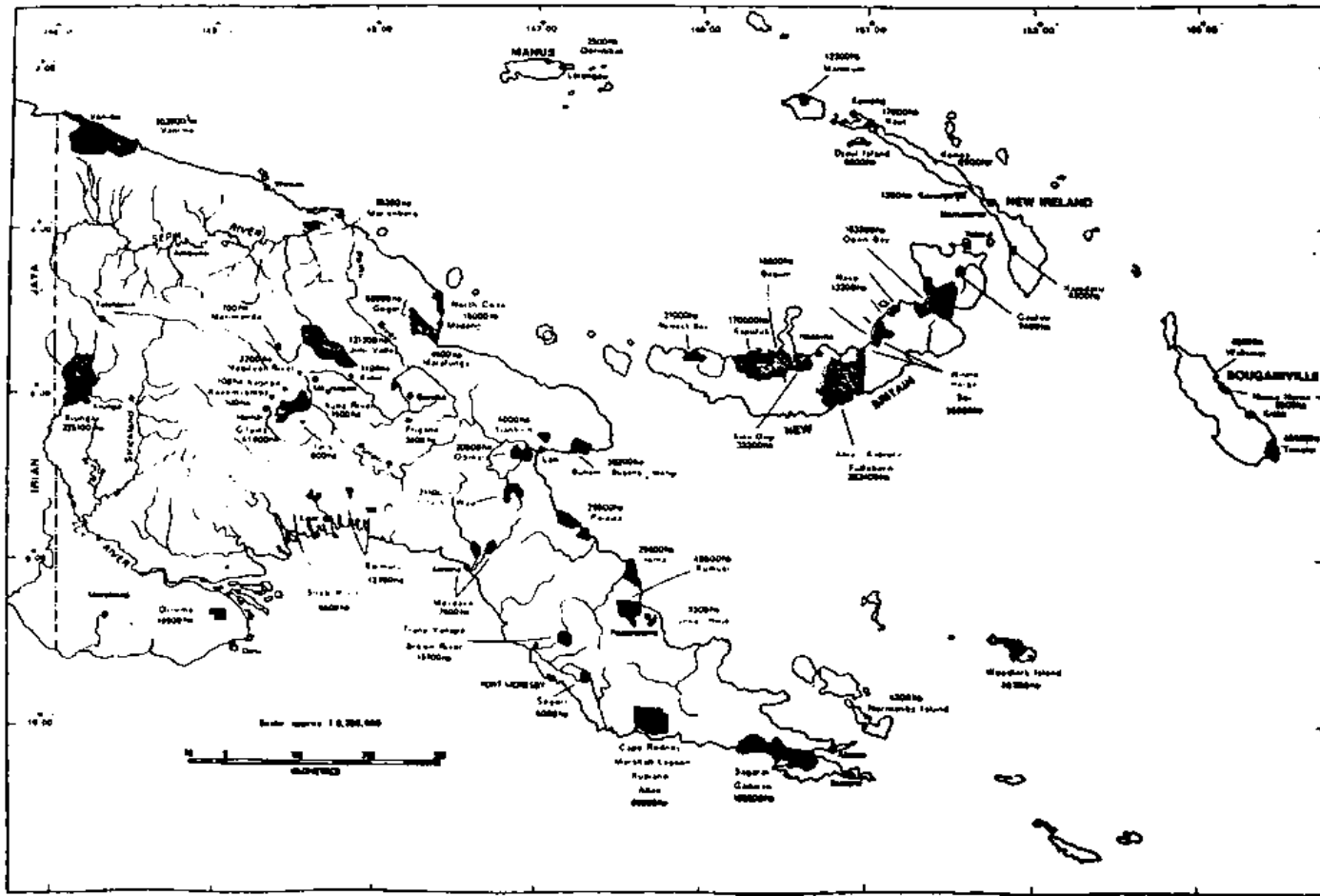
DAR (or D4S or PAR) - Dressed all round, dressed four sides or planned all round.

c) Milled Timber - A machine shaped or moulded timber. E.g. tongue and groove, rebated dowels etc. .

1.7. Common timber



FOREST REGIONS OF THE WORLD



MAJOR TIMBER AREAS**SOME MAJOR COMMERCIAL TIMBER:**

<u>TIMBER</u>	<u>COLOUR AND CHARACTERISTICS</u>		<u>PROVINCE</u>	<u>USES</u>
	SAPWOOD	HEARTWOOD	MAP No. 3 REFERENCE NUMBER	
AMBEROI	White	White to cream. Ripple marks.	General	Veneer, plywood, interior finish, formwork, concrete shuttering, packing cases, low quality matches. Floaters for rafting sinker logs.
BASSWOOD	White	Pale yellowish cream. Tension wood.	General General General 10.11 General	Moulding, veneer, boards, lining, joinery, interior finish, match splints, match boxes, shuttering, turnery, dowels, pattern making, packing cases, furniture, cabinet work, weatherboards, shingles, drawing-boards.
BEECH, P.N.G.	Creamy-yellow	Pink-brown to red-brown.	4 1, 3, 4, 1, 3, 4, 3, 4, 3, 4, 4,	General construction, flooring, furniture, scantling, panelling, tool handles, joinery, window frames and sills, turnery, sliced veneer, bridge decking, sleepers, boat building.

BEECH, WAU	White	Pale brown to golden brown.	4, 10, 4, 4, 10, 3, 4, 7, 8,	Furniture, veneer, plywood, moulding, fine finishing, boat building (including decking) canoes, panelling, cladding, flooring, lining, turnery, carving, joinery, cabinet work.
BEECH,	Pale Yellowish Brown.	Pale brown to honey-brown Siliceous Greasy nature Aromatic	3, 11,	Furniture, cabinet work, drawer slides and sides, face veneer, plywood, boat building, light framing, moulding, wall panelling, interior trim, panelling, linings, cappings, joinery, window & door frames, brush handles, turnery, bobbins, clog soles, pattern making.
OAK, P.N.G.	Pale brown	Brown. Tannin odour	3,4,	Plywood, sliced veneer, casks, interior fittings, cabinet making, general construction, furniture, panelling, flooring, shingle & shakes boat building, lining, joinery.
OAK P.N.G.	Pale brown	Brown or pinkish - Tannin odour.	1,3,4,5, 7,9, 5 3,4, 4, 3,4,7, 1,3,8,9,	Plywood, sliced veneer, casks, interior fittings, cabinet making, general construction, furniture, panelling, flooring, boat building tool handles, shingles & shakes, joinery, lining.

22/10/2011

meister10.htm

OAK, WHITE TULIP	Straw to pale yellow	Pale brown to cream. Ripple marks.	2,7,	General construction, bridge and wharf superstructure, interior finish, cabinet work, joinery, moulding, furniture, panelling, veneer, tool handles, cladding, lining, steps, hand rail.
ROSEWOOD	White to pale yellow	Red-brown golden brown or blood-red Ripple marks Fragrant odour.	1,2,7,9,	Furniture, cabinet work, joinery, boat building, rifle, butts, veneer, plywood, flooring, decorative panelling native artifacts, knife handles, carpenters levels drawing instruments, turnery, musical instruments.
TAUN	Pink	Pinkish-brown or blood-red brown. Pink and white deposits. Contains saponin	General	General construction, panelling, railing, domestic flooring, veneer, joinery furniture, cabinet work, boat building, spars, mouldings, interior finish, dowels, door and window frames, fibreboard billiard tables, tool handles.
WALNUT, P.N.G.	Pale yellow.	Grey-brown with black streaks. (Tension wood)	1,2,6,7,10 1.2.	Decorative veneers, plywood, furniture, joinery, cabinet work, interior finish, light construction, panelling, shop fitting, moulding, flooring, turnery, cladding, lining, carving, artifacts.
CEDAR.	Pale pink.	Brown or pale	1.6.8.10.	Light construction. interior finish.

PENCIL

pink-brown
(Siliceous)

Contains

saponin

Red-brown of 3,7,10,
beef red. Dark
coloured,
deposits.moulding, furniture, boat building,
joinery, dowels, cabinet making,
panelling, veneer, flooring, turnery,
carving.

CEDAR, JAVA

Pink or
pale red-
brownGeneral construction, interior finish,
joinery, flooring, furniture,
blacksmiths charcoal, paving blocks in
temperate climates, interior trim,
lining, cover moulds, rails, scotia,
piles, posts, poles, decking, sleepers,
billiard cue butts.

CEDAR RED

Pinkish-
whiteDark red-
brown

3

Aromatic
odour
White/pink
deposits.Interior finish, cabinet work, joinery,
furniture, canoes, decorative wall
panelling, face veneer, boat building,
bend work, cigar boxes, clog soles,
ornamental work, artifacts, louvred
doors, pattern making, shingles,
weatherboards.CHEESEWOOD, Yellow
YELLOWDark yellow
Greasy nature
Bitter taste

General

Light framing, moulding, interior
joinery, windowsills, drawer slides,
shingles, weatherboards, cladding.

EBONY, BLACK White

Black or black
with brown
strips

9

Decorative sliced veneer, billiard cue
butts, carving, musical instruments,
brush-backs, marquetry, inlay,
chessmen, ornamental work.

EBONY,

White

Ivory

7

General construction, telegraph poles,

WHITE ERIMA, P.N.G.	Pale yellow to pale brown	Pale brown grey-yellow, purplish cast. Foetid odour.	7,8,10,	heavy duty flooring, interior finish moulding, veneer, plywood, weatherboards shelving, cottins, canoes, carcassing, joinery, concrete shuttering, shingles, match boxes.
FIG, P.N.G.	White	Pale yellow	General	Moulding, interior work, cladding, concrete formwork, fruit cases.
GALIP	Pale brown	Pink-brown or red-brown	1,10,	General construction, moulding, interior, finish, veneer, utility furniture, flooring, panelling, door and window frames, joinery cabinet work.
GUM, WATER	Pale-brown	Brown to red- brown	General	General construction, boat building, crossarms, sleepers, decking, stairs, steps, flooring, windowsills, furniture, joinery, piles, poles, posts, pallets, handles
KAMARERE	White top pink	Red-brown	10,	General construction, cabinet work furniture, joinery, poles posts piles, interior trim, plywood, panelling, scanting, flooring, boat building, moulding, cladding, decking, lining, sleepers, tool handles
KAPIAK	Pale yellow	Yellow-brown to gold-brown White deposits	General	Light framing, interior trim, moulding, shuttering, crates, canoes.

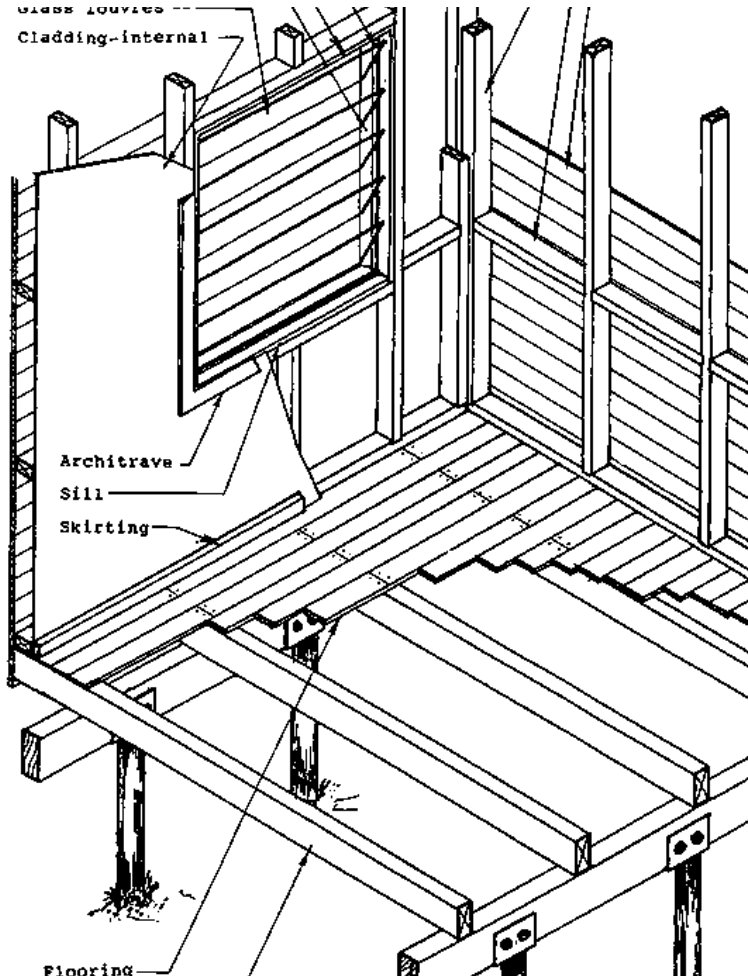
KWILA	White or pale yellow	(Siliceous)	1,2, 1,2,	Heavy construction, flooring sills, boat building, bridge and wharf superstructure, decking, steps, truck bodies, crossarms, carving, turnery, posts, poles, furniture, bench and counter tops, switchboards, joinery, cabinet work, interior fittings, decorative veneer, panelling, artifacts, sleepers.
		Brown, dark brown or golden brown yellow deposits. leathery odour		
MANGO	Straw to pale brown	Dark pink brown, yellow splashes. Tension wood.	3,7,	General construction, interior trim, moulding, attractive rotary veneer, plywood, furniture, interior joinery, cabinet work, flooring, decorative wall panelling, shelving.

1.8. Specification of material

Stump	100 x 100	150 x 150
Bearer	150 x 75	200 x 75
Joist	100 x 50	100 x 75
Bottom-plate	75 x 40	
Studs	75 x 40	
Nogging	75 x 40	
Braces	50 x 20	75 x 20

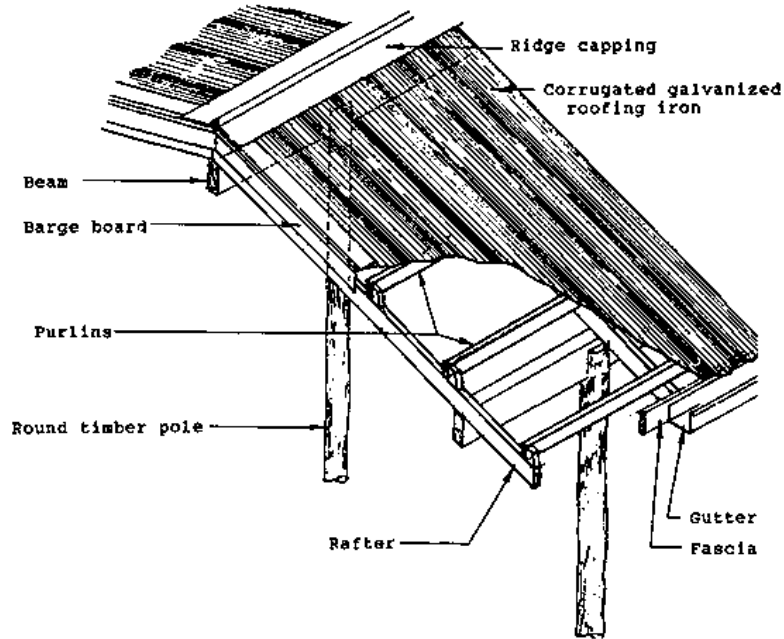
Trimmer	75 x 40			
Jamb	140 x 25	140 x 30		
Head	140 x 25	140 x 30		
Sill	140 x 45			
Architrave	25 x 50			
Skirting	50 x 25	75 x 25		
Flooring	100 x 25			
Cornerstud	100 x 100	75 x 75		
Top-plate	75 x 40			
Ceiling joists	100 x 50	100 x 75		
Rafter	100 x 40	100 x 50		
Purlin	75 x 40	75 x 50	50 x 50	
Beam or Ridge	150 x 40	150 x 50		
Barge board	150 x 25	100 x 25	150 x 30	200 x 30
Fascia board	150 x 25	100 x 25	150 x 30	200 x 30
Weather board	135 x 20			
Tread	255 x 30			
Riser	190 x 20			
Handrail	100 x 50	100 x 40	75 x 75	75 x 40
Stringer	250 x 40	200 x 40		



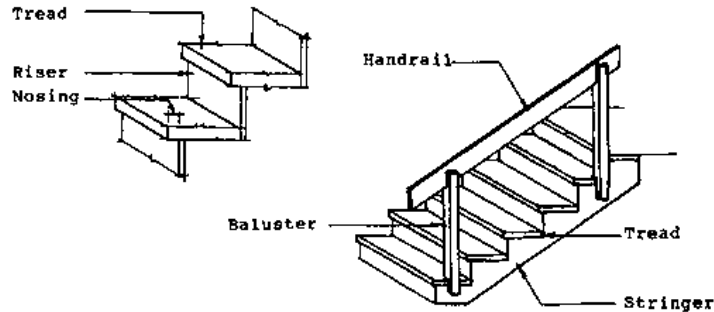




Figure

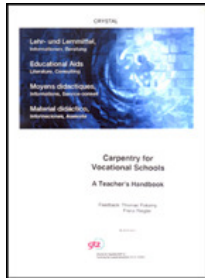


Figure



Figure

[Home](#) > [ar.cn.de.en.es.fr.id.it.ph.po.ru.sw](#)



 **Carpentry for Vocational Schools - A Teacher's handbook (GTZ, 252 p.)**

 **(introduction...)**

 **PREFACE**

 **1. TIMBER**

  **2. SCALES**














 **3. CONCRETE**

 **4. CONCRETE FORMWORK**

 **5. FOOTINGS**

 **6. TOOLS USED ON BUILDINGS**

 **7. FASTENERS**

-  **8. FOUNDATION**
-  **9. JOINTS**
-  **10. BRACING**
-  **11. WALLFRAME**
-  **12. CEILING**
-  **13. ROOFING**
-  **14. WINDOWS**
-  **15. OUTSIDE CLADDING**
-  **16. FLOORING**
-  **17. ELECTRICITY**
-  **18. PLUMBING**
-  **19. INSIDE CLADDING**
-  **20. DOORS**
-  **21. SKIRTING, ARCHITRAVES, CORNERSTRIPS**
-  **22. PAINTING**
-  **23. STAIRS**
-  **24. HARDWARE**
-  **25. WATERTANKS**
-  **BIBLIOGRAPHY**

2. SCALES

TOPIC: 2. SCALES

INTRODUCTION: Drawing and reading in scale is very difficult and needs a lot of time

to make the students familiar with it.

Therefore it depends much on the emphasis put on this topic if the students are to be able to use scales in practical drawing and work.

OBJECTIVES:

- **Students should be able to distinguish between a drawing in the real measurements and drawing in scale.**
- **Students should be able to describe in words and numbers the relationship between two objects and/or numbers.**
- **Students should be able to read and interpret a scale drawing of a simple piece of furniture.**
- **Students should be able to do a neat and accurate scale drawings of top, front and side views of simple objects.**

METHODS:

- **Explain why scale drawing is necessary.**
- **Explain what a ratio is.**
- **Prepare worksheets with figures drawn in scales 1:10, 1:20, 1:50 and 1:100. Write the scale to it and let students work out the actual measurements and write them to the figures.**

- **Prepare another worksheet with numbers of actual measurements which must be converted for scale drawing by ratios of 1:10, 1:20, 1:50 and 1:100.**
- **Prepare a scale drawing of a house plan in the scale of 1:50 without given measurements. Students have to find out the actual measurements of the house.**
- **Finally students can do their own scale drawing. Give each student a piece of paper and draw a plan of a simple house with the actual measurements on the black board. Students have to draw the house to a scale of 1:100 on their paper.**

NOTE: After this topic prepare a worksheet for the students with questions about converting actual measurements into scale measurements and assess it later.

On maps, plans and drawings the size of things are reduced to make them small enough to fit on the paper or in the case of small parts increased to show detail.

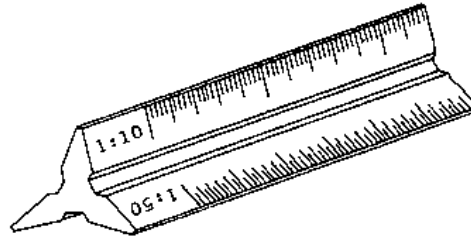
A SCALE can be expressed in the form of a RATIO where the unit of both numbers must be the same, eg. 1:50 means that 1 mm on the drawing represents 50 mm on the building and 1 on the drawing represents 50 cm on the building.

On a detail drawing of small parts (eg. joint) which has been enlarged for clarity the scale may read 5:1.

REMEMBER: The first number in the ratio represents the measurement on the drawing and the last number represents the actual measurement on the building, part or ground.

A scale can also be a ruler like a draughtsmans **SCALE RULER or a ruler drawn on a map. In both cases each division on the ruler represents an **ACTUAL** measurement.**

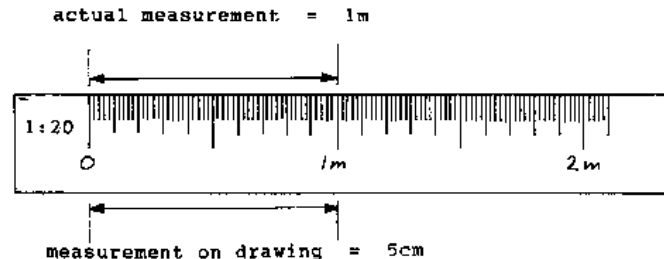
Scale rulers are made in different scales: 1:20, 1:25, 1:50, 1:75, 1:100 and 1:125.



Scale ruler

When drawing a plan in a scale you must write down in which scale the drawing is made in order to enable anybody to read the plan.

Eg. 1)



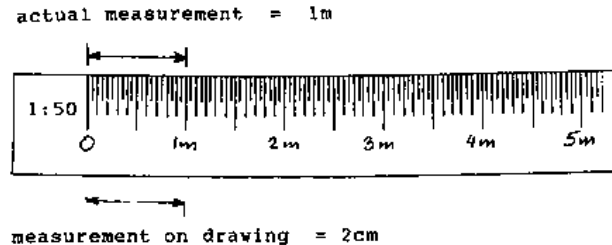
Figure

If you measure the same distance with a straight ruler, you will measure 50 mm on the paper.

In case no ruler is available the actual measurement of 1 m = 1000 mm is divided by the number of the scale = 20.

The result, 50 mm, is the measurement on the drawing.

Eg. 2)



Figure

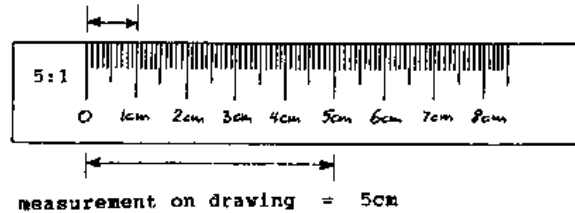
If you measure the same distance with a straight ruler, you will measure 20 mm on the paper.

In case no scale is available the actual measurement of 1 m = 1000 mm is divided by the number of the scale = 50.

The result, 20 mm, is the measurement on the drawing.

Eg. 3)

actual measurement = 1cm



measurement on drawing = 5cm

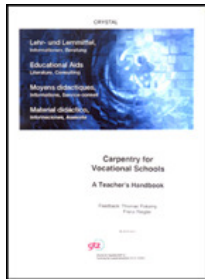
Figure

For enlarging very small things in a scale eg. 5:1, you have to multiply the actual measurement = 1 cm with the number of the scale = 5.

The result, 5 cm, will be the measurement on the drawing.



[Home](#) > [ar.cn.de.en.es.fr.id.it.ph.po.ru.sw](#)



 **Carpentry for Vocational Schools - A Teacher's handbook (GTZ, 252 p.)**

  **3. CONCRETE**

 **(introduction...)**

 **3.1. Composition of concrete**

 **3.2. Proportions for mixing concrete**

 **3.3. Reinforcing concrete**

 **3.4. Finishing concrete**

Carpentry for Vocational Schools - A Teacher's handbook (GTZ, 252 p.)

3. CONCRETE

TOPIC: 3. CONCRETE

INTRODUCTION: This topic teaches students what concrete is made of; the right proportions of sand, gravel cement and water; how concrete is reinforced and how to finish a slab.

Concrete work is an important part of building a house, but this topic is quite broad and it might be difficult to teach the whole topic. Select those chapters where a real need exists according to the aim of the school.

OBJECTIVES:

3.1. Students must be able to name the raw materials in concrete and describe their characteristics.

3.2. Students should know the meaning of the "ratio" used in mixing concrete and the amount of each material needed to make one cubic metre of concrete. Students also should know the correct ratio for different purposes like foundations, walls or concrete blocks.

3.3. Students must know why concrete has to be reinforced, the, different reinforcement bars and meshes, its applications and the correct way reinforcement bars or mesh are laid.

3.4. Students should be able to describe the correct procedure for making a

smooth finish of a concrete surface and the tools needed for this job.

METHODS:

3.1. First the objective is introduced in the classroom. We prepare samples of cement, sand and gravel to show the materials concrete consists of.

3.2. After explaining this chapter in the classroom, the samples of cement, sand and gravel are mixed in the right proportions with water. A small wooden form is prepared where the concrete is poured, consolidated and smoothed.

3.3. Prepare samples of different reinforcement bars and mesh and display them in the classroom where we explain their characteristics and uses. Demonstrate how reinforcement bars and mesh are jointed when necessary.

3.4. Again, prepare a small wooden form and after the explanation in the classroom, mix some concrete and pour into the wooden form where some reinforcement bars have been placed. Strike off the excess concrete and smooth the surface as described earlier in this chapter.

NOTE: The size of the wooden forms should not exceed 500 mm x 500 mm and 60 mm in height. When both concrete samples have been moved to dry for at least one week, take out the wooden forms and try to break both by supporting the concrete only on two outside edges and placing a heavy load in the middle. Students will see, that concrete without reinforcement will break easier.

At the end of this topic prepare a worksheet with questions for the students to reinforce this topic.

3.1. Composition of concrete

The concrete consists of Cement, Fine aggregate. Rough aggregate and Water. Concrete is used to make concrete slabs, wall foundation, septic tanks etc...

a) Cement: The most commonly used cement is Portland Cement. Cement itself is a grey powder which is made up of limestone, clay and marl. In the cement factory the raw material (limestone, clay, marl) are crushed. Afterwards these go through the raw mill for simultaneous grinding and drying of the raw material. If this process is done the raw material becomes raw meal and the raw meal is ready now for the rotary kiln, where the raw meal is fired. From the rotary kiln, the next step is the clinker cooler, to cool down the cement. At this step the raw material is already a cement and is packed in 50 kg paper sacks for sale.



Figure

b) Fine Aggregate: Fine aggregate or sand consists of small grain, small pebbles or particles of crushed stone that will pass through a 6.350 mm wire mesh screen. The sand should be clean, hard, sharp and well graded. Well graded aggregate means aggregate which is not uniform in size.



Figure

c) Coarse Aggregate; Coarse aggregate can be stone, crashed stone or gravel. Its depend on the project which coarse aggregate is suitable. Coarse aggregate should be clean, hard and free from harmful amounts of vegetable matter, loam or clay.



Figure

The ideal composition of coarse aggregate is as follow:



30% coarse = 25 - 32 mm in size



30% medium = 16 - 25 mm in size

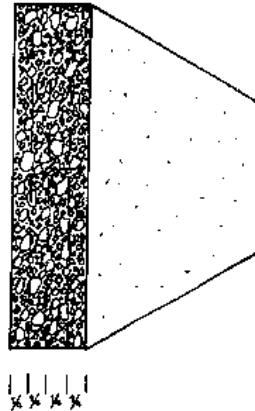


20% fine = 8 - 16 mm in size



20% very fine = 4 - 8 mm in size

The largest particles should not be more than one quarter the thickness of the wall or slab.



Figure

3.2. Proportions for mixing concrete

Concrete mixes are designated by three numbers, in some cases there are only two numbers. The ratio describes the quantity relationship which is determined by the architect or engineer.

a) The ratio 1:2:4

- The ratio 1 : 2 : 4 is defined :

- 1 part cement**
- 2 parts fine aggregate/sand**
- 4 parts rough aggregate/stone or gravel**

- For one cubic metre of 1 : 2 : 4 concrete uses the following:

- 8 Bags of cement**
- 0.5m³ of fine aggregate/ sand**
- 1.0m³ of coarse aggregate/gravel**
- 200 litre of water**

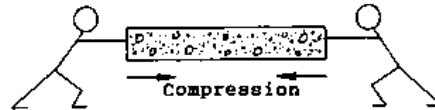
b) Different ratios

- 1:2:4 is used for foundations, footing, footpath, troughs, slab, wall, bottom of the septic tank, etc.**
- 1:2:3 is used for the walls of a septic tank,**

- **1:2:2 is used for the top of a septic tank,**
- **1:4 is used for concrete blocks.**

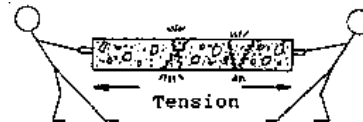
3.3. Reinforcing concrete

a) **Forces: Concrete is very strong when it is subjected to compressive forces (being crushed). E.g.: low house stump of concrete, concrete footings etc..**



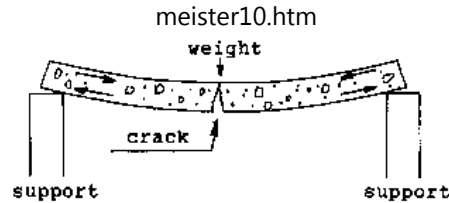
Figure

Concrete is weak when it is subjected to tensile forces (being stretched). E.g. concrete lintels, concrete beams, concrete stairs etc...



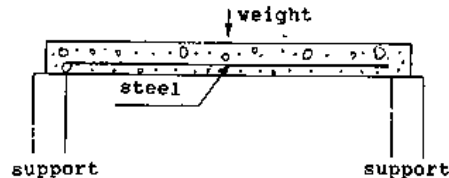
Figure

To illustrate the points made above we suspend a concrete beam between two points. The weight from above causes the beam to bend producing compressive stress along the top edge of the beam and tensile stress along the bottom edge causing the beam to crack.



Figure

If we place a bar of steel, which has very high tensile strength, in the concrete near the bottom edge it would prevent the beam from stretching and cracking, this strengthening of concrete is called reinforcing.



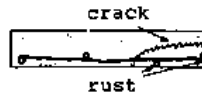
Figure

b) Rules for laying reinforcing steel: It is important that reinforcing steel is placed correctly and where heavy loads are involved (e.g. bridges, concrete buildings etc.) the position and sizes must be calculated by an engineer and his drawings and specification must be strictly followed.

When you place reinforcing steel you must remember the following points:

- To make sure that the concrete sticks to the steel properly. The steel must be clean from rust, grease and dirt. If necessary use a wire brush to clean it

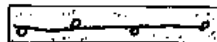
- **Steel must be well covered with concrete on all sides to ensure moisture cannot reach it to cause rusting which in turn causes the concrete to crack up.**
- **When making a reinforced slab lift mesh off the ground with stones or special spacers. In formwork with reinforcing bars use small concrete blocks or special spacers to make sure the steel is the correct distance from the formwork.**
- **Wire used to tie the steel must not be galvanised. If it is, you must burn off the galvanised coating before use.**



steel to close to bottom edge



steel to close to top edge



that is the right way

c) Codes: On as work drawing you find reinforcing fabric and bars referred to with a code. E.g. F62, C12, R10 etc.. As fabric and bars are not labelled you must know the meaning of the codes in order to recognize the various types of reinforcing steel found on a building site or in the store yard.

Reinforcing fabric (mesh):

- There are two types of reinforcing fabric which are made in sheets of 6m x 2.4m or in the case of thinner steel in rolls of 60m x 2.4m.

Square mesh:**Example - F62**

"F" means fabric

"6" means that wires are 6 mm dia.

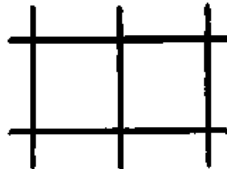
"2" means the spaces are 2 decimetre - 200 mm

Example - F71

"F" means fabric

"7" means that wires are 7 mm dia.

"1" means the spaces are 100 mm



Square mesh

Rectangular mesh:**Example - F818**

"F" means fabric

"8" means wire A is 8 mm dia.

"1" means the short side of rectangle is 1 decimetre (100 mm). The long side is normally twice the short side.

"8" means wire B is 8 mm dia.

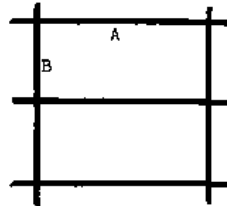
Example - F1018

"F" means fabric

"10" means wire A is 10 mm dia.

"1" means the short side of rectangle is 100 mm

"8" means wire B is 8 mm dia.

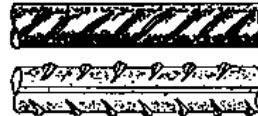


Rectangular mesh

Reinforcing bars:

- There are two types of reinforcing bars supplied in 6 m and 10 m length for plain bars and 5 m or 10 m length for deformed bars.

Plain, round bar:

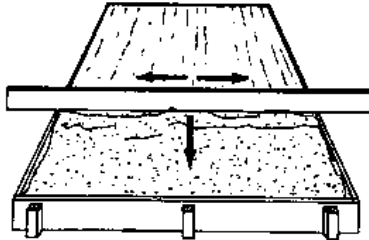
Example - R10**"R" means round****"10" means 10 mm dia,****Plain, round bar****Deformed bar (contorted)****Example - C12****"C" means contorted****"12" means 12 mm dia.****Deformed bar (contorted)**

- Be aware that the code letter for deformed bars is not always a " C ".

3.4. Finishing concrete**a) Striking off excess concrete:**

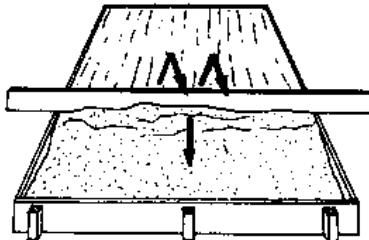
After the formwork has been filled with fresh concrete just above the formwork the concrete is consolidated in order to get out all air pockets inclosed into the concrete.

The excess concrete is struck off with a specially prepared wooden board or magnesium rod across the concrete, starting on one side of the concrete. It normally requires two people to do it properly.



Figure

Consolidation and strike off are often combined into a single operation by lifting the board above the fresh concrete consolidate the mixture by bouncing the concrete using the bottom edge of the board.



Figure

Return the board to the starting point and strike off by moving forward with saw-like

motions across the top of the form.

Keep the top-edge of the formwork and the edge of the strike-board clean and repeat the process forming a true surface.

b) Hand floating concrete

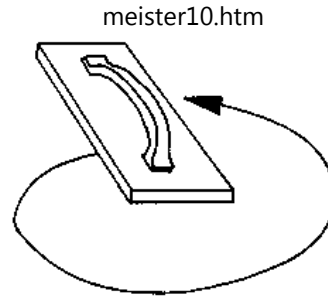
The size and the dimension of the concrete slab will determine the procedure of hand floating concrete.

After striking off the excess concrete, there must not be water on the surface. If the concrete has been mixed too wet you have to wait for some time till the water has gone. If necessary speed up this process by spreading cement powder on the wet surface.

When surface has dried up, start floating on the farthest corner. To avoid stepping in the wet concrete, place timber boards on the places you have to stand on.

When concrete is too dry you may have to wet it with water in order to produce a smooth finish.

Floating is done by moving the float in short circular motions. Keep a trowel near by to fill in or to remove stones from the surface.



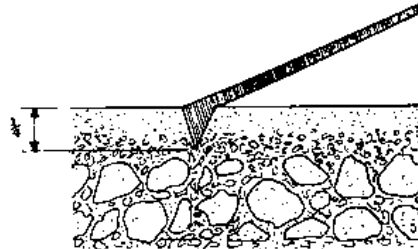
Figure

c) Control joints:

When having large areas of concrete slab, it is advised to divide the whole slab into smaller sections, because of the shrinkage of the concrete during the drying process.

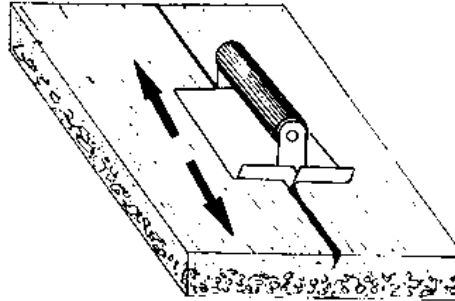
The planned spacing of the control joint weakens the slab at these joints. In case the concrete cracks because of the shrinkage, it will crack on the weakened sections.

The joints do not extend to the full depth of the slab. They are usually cut one quarter of the depth of the slab and are made with a GROOVER.



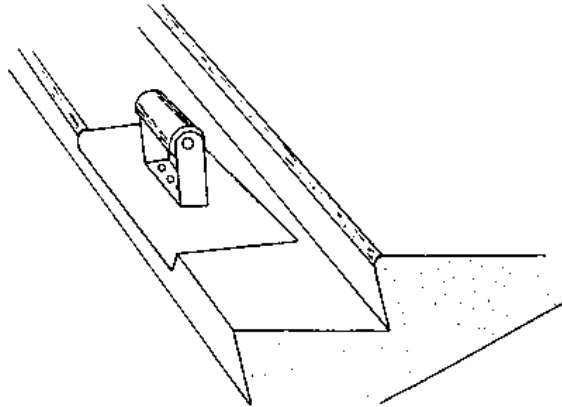
Figure

Put a straight board across the concrete and push the groover alongside the board in the fresh concrete. Push the groover back and forth until a smooth groove has been formed into the concrete.

**Figure****d) Edging Concrete:**

Edging concrete is done when all water and sheen (glossy appearance) have left the surface. Rounding all the edges of the concrete prevents breaking off. This is necessary on steps or other parts where there is danger of breaking off corners.

Rounding off the edges is performed by using an EDGER.



Figure

It should be run back and forth until the contour is shaped. This operation can be done easily if it is done easily when the concrete is firm but still moist.



[Home](#) > [ar.cn.de.en.es.fr.id.it.ph.po.ru.sw](#)

 **Carpentry for Vocational Schools - A Teacher's handbook (GTZ, 252 p.)**

➔  **4. CONCRETE FORMWORK**

 **(introduction...)**

 **4.1. Formwork for concrete slab**

 **4.2. Formwork for concrete wall**



4.3. Formwork for concrete stairs

4.4. Formwork for septic tank

Carpentry for Vocational Schools - A Teacher's handbook (GTZ, 252 p.)

4. CONCRETE FORMWORK

TOPIC: 4. CONCRETE FORMWORK

INTRODUCTION: This topic teaches students the different types of concrete formwork which must be strong enough to withstand the pressure of the wet concrete.

Carefully select the chapters which are needed to meet the aim and the syllabus of the school.

OBJECTIVES:

4.1. Students must be able to make a simple formwork for a concrete slab. When possible demonstrate it on a small project. E.g. a watertank foundation.

4.2. Students should be able to identify the parts of a formwork for a concrete wall. They also should be able to describe the process of making a formwork for a concrete wall.

4.3. Students must be able to name the parts of a stair, its correct measurements and describe the process of making the formwork for concrete stairs.

4.4. Students should know the correct names for the parts of the formwork for septic tanks and the correct measurements.

METHOD: Prepare photocopies of the drawings taken from this topic for the students for better understanding. After introducing the objectives of this topic, students take notes from the blackboard and glue the copies of the drawings in their trade theory books.

This topic might be difficult to demonstrate on a practical example because of the large amount of timber needed to do such a demonstration. However, if there is a building project within the school going on, take this opportunity to show the students the correct procedure for making such a formwork.

NOTE: At the end of this topic prepare a worksheet for the students to reinforce their knowledge.

Formwork is a temporary construction used to hold concrete in place while it sets. As concrete is very heavy, formwork must be solidly constructed and firmly braced and supported. To ease the removal of the formwork after the concrete is dry the sheathing must be well oiled before pouring the concrete. The material used for sheathing are boards, which have a thickness of 25 mm. In order to get a smooth surface or if a high wall is required, nowadays 19 mm plywood is often used. Wet the timber of the sheathing before pouring concrete; this will, swell the timber and tighten the joints and thus prevent the escape of water from the mix. It will also prevent the too rapid

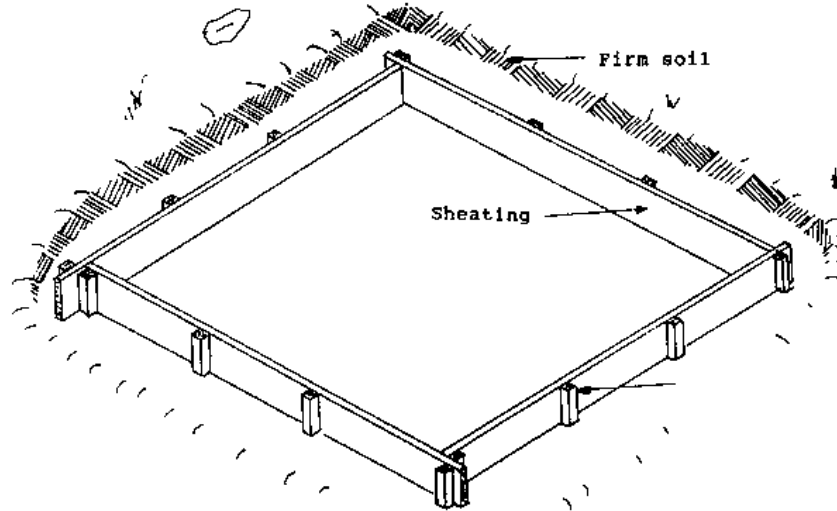
drying of the outer part of the concrete by absorption of water by the boards.

4.1. Formwork for concrete slab

A slab is made for concrete path, driveways, tank stands, floors etc... As slabs are relatively thin the pressure on the formwork is low, demanding a less solid construction. The soil is slightly excavated and the pegs driven into the ground at approximately 600 mm intervals. The boards are nailed on the pegs.

a) Procedure for making a concrete slab:

First place the pre-assembled wooden forms with the aid of building rope to the correct height and line. If it is necessary brace the forms strongly so they will not weaken when they are filled with concrete. Measure diagonals to ensure squareness. Fill in the wooden forms with concrete.

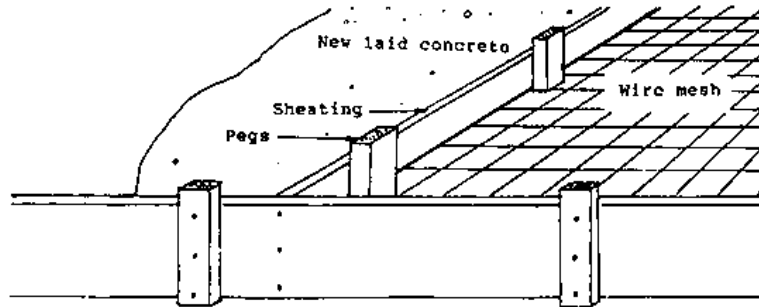


Figure

b) Joining concrete slab:

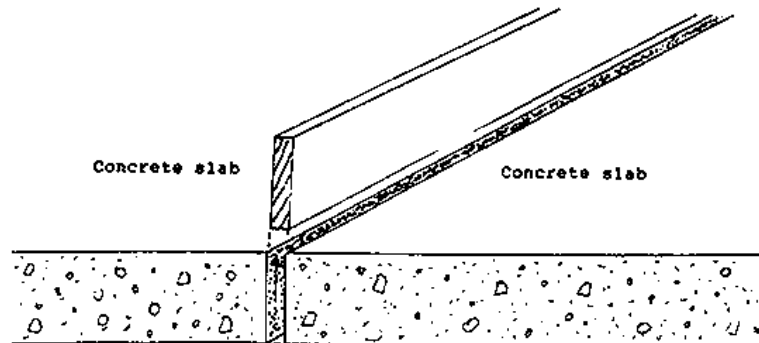
Very seldom can any type of concrete construction be built without joints. There are two types of joints in concrete work - construction joint and contraction joint.

- Construction joint appear wherever concreting is stopped or delayed to the extend where fresh concrete has to be placed against hardened concrete.**



Figure

- Concrete expands and contracts with extremes of temperature or with variations in temperature. It may shrink during the hardening process. To eliminate random cracks, contraction joints are build into the concrete.



Figure

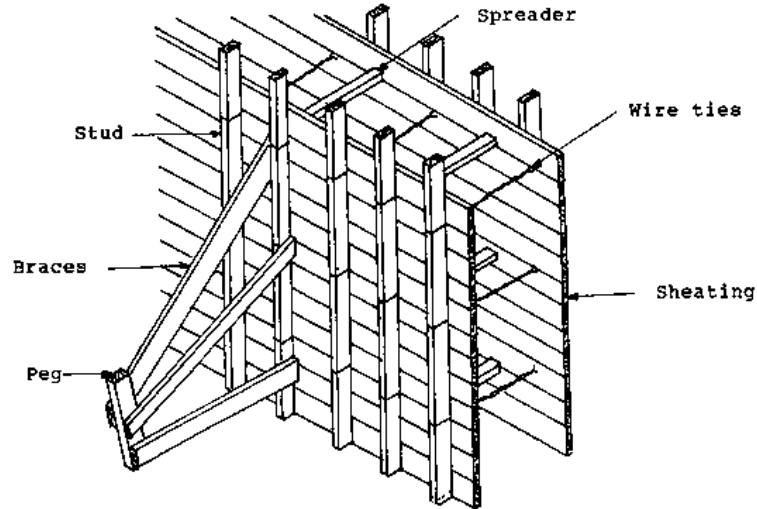
4.2. Formwork for concrete wall

Formwork for a concrete wall is normally built up on both sides of the wall. Reinforcement bars are laid on wires before the spreaders are placed and the wall is tied. The studs are approximately 600 mm apart. All studs are braced.

a) Formwork for high concrete wall:

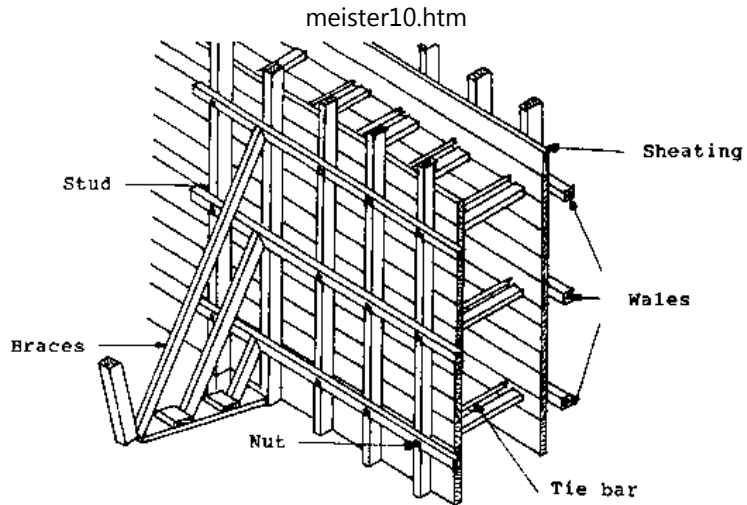
There are two methods of fixing wall forms, one with "wales" and the other without wales.

- Wall forms without wales: The sheating is made in panels of a size convenient to handle and are placed between two rows of studs. Wire ties are used to hold the sheating, with spreaders between to keep them in the correct distance apart.**



Figure

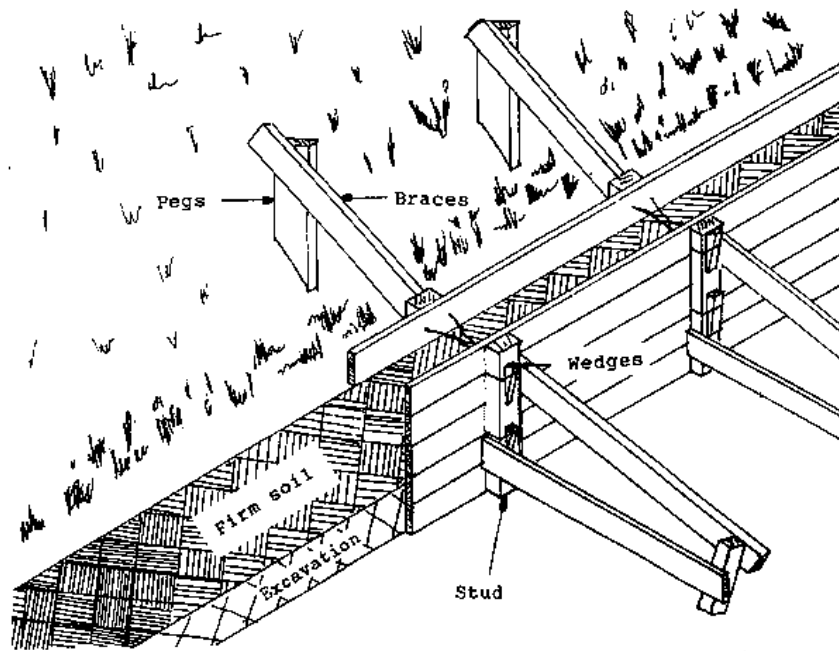
- Wall forms with wales: If there is danger of the wall forms getting out of line, the load of the concrete, then wales should be used. In the waling method, horizontal members (wales) are fixed and bolted trough at the side of the studs. Spacing pieces are again required to keep the sheathing the correct distance apart (thickness of concrete wall). As the bolts have to be removed from the concrete they should be greased before pouring concrete.



Figure

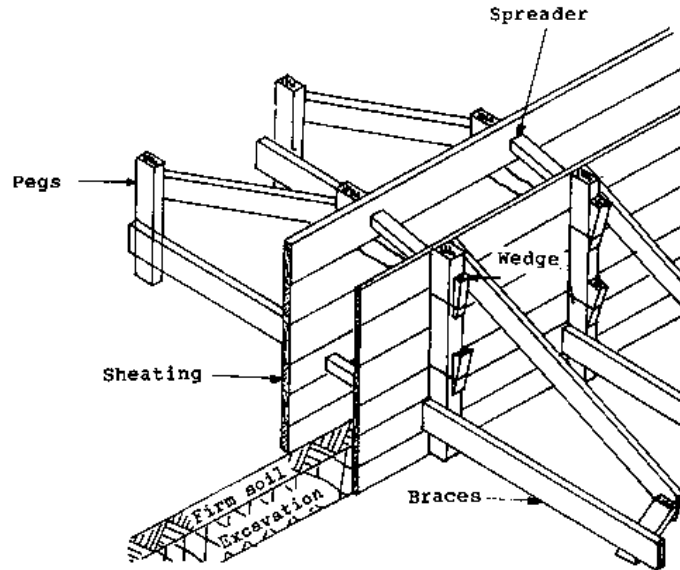
b) Formwork for a concrete wall on a slope:

On sloping ground an earth face may form one side of the formwork.



Figure

c) Formwork for a footing wall:

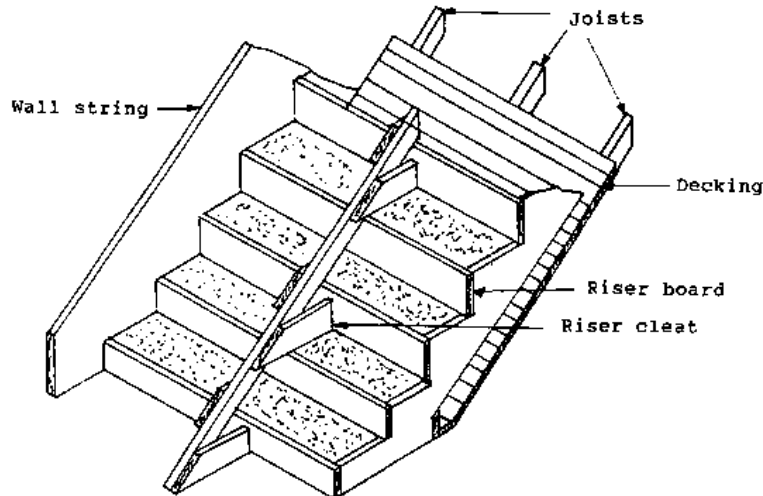


Figure

4.3. Formwork for concrete stairs

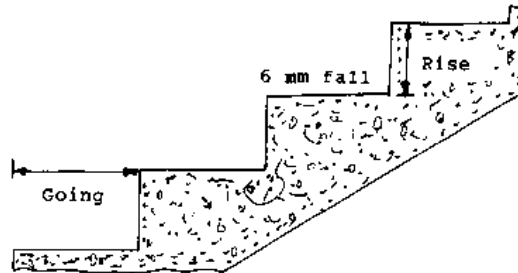
Concrete stairs also require temporary formwork and the necessary check timber supports. As with timber stairs, check the height from floor to floor as the first step in the preparation of a set out. Divide this total rise into a suitable number of risers and then calculate the proportionate size to the go, as described in the chapter dealing with timber stairs. A flight of stairs should be easy and comfortable to climb. Certain dimensions must be followed to ensure this.

- **Maximum rise is 190 mm.**
- **Minimum going is 255 mm.**
- **One going plus two rises should equal 585 mm to 625 mm.**
- **Before pouring the concrete reinforcing mesh is laid in position.**



Figure

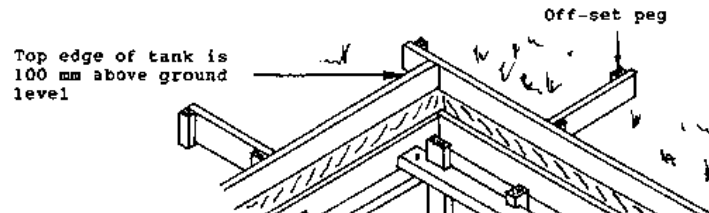
- **External concrete stairs should also have a 6 mm fall on the top of the step to allow rainwater to run off.**

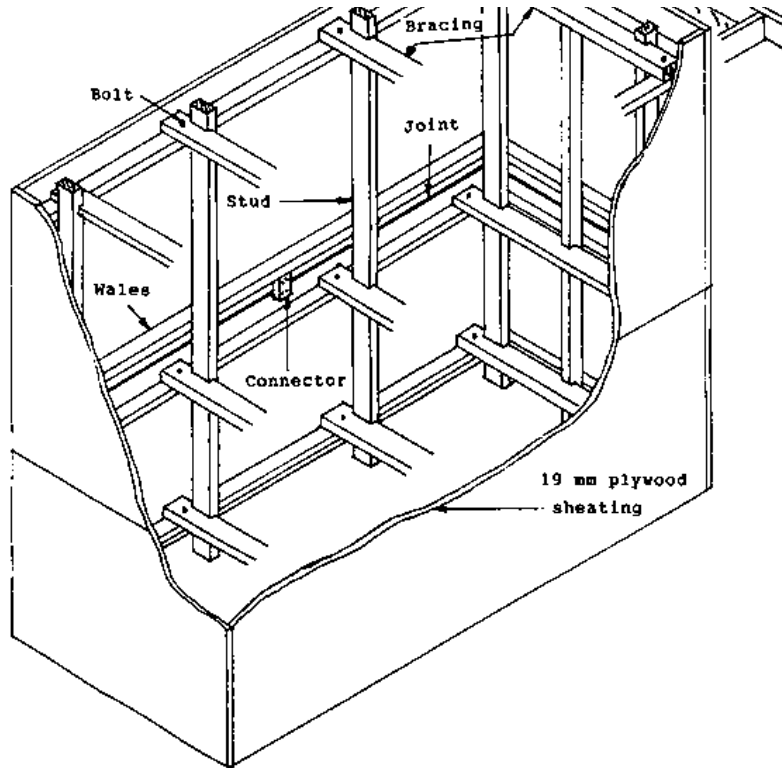


Figure

4.4. Formwork for septic tank

The excavation for a septic tank must be as accurate as possible (sides must be plumb and hole square) as the sides of the hole form one side of the formwork. Cut and test assemble the formwork above ground. The sides should be made in two sections to make handling easier. Remember to make provisions for drain pipes. The bottom of the septic tank is sloping. Use the bottom edge of the side panel to get the exact slope. The bottom slab is poured first using bottom edge of side panel for accuracy. When concrete has set slightly the formwork is placed and the sides poured. The top edge of the tank is 100 mm above ground level to prevent rainwater entering. The sheathing usually used for septic tank is 19 mm plywood.





Septic tank

