

Manufacture of Ceilings – Course: Timberwork techniques. Instruction examples for practical vocational training

Table of Contents

<u>Manufacture of Ceilings – Course: Timberwork techniques. Instruction examples for practical vocational training</u>	1
<u>Preliminary Remarks</u>	1
<u>Instruction Example 4.1.: Calculation of Cross Sections of Wooden Beams</u>	1
<u>Instruction Example 4.2.: Determination of the Pitch Size</u>	4
<u>Instruction Example 4.3.: Preparation of a List of Timber</u>	7
<u>Instruction Example 4.4.: Preparation of the Wall Plate Bearing</u>	12
<u>Instruction Example 4.5.: Placing of Wall Plates</u>	14
<u>Instruction Example 4.6.: Preparation of the Wooden Beam Framing</u>	17

Manufacture of Ceilings – Course: Timberwork techniques. Instruction examples for practical vocational training

Institut für berufliche Entwicklung e.V.
Berlin

Original title:
Lehrbeispiele für die berufspraktische Ausbildung
“Herstellen von Deckenkonstruktionen”

Author: Rolf Becher

First Edition © IBE

Institut für berufliche Entwicklung e.V.
Parkstraße 21/23
13187 Berlin

Order No.: 93–33–3604/2

Preliminary Remarks

The present booklet contains 6 selected instruction examples to practise and consolidate knowledge and skill in the manufacture of ceilings.

The instruction examples have been selected so that the individual exercises can be practised separately or successively, one based on the previous one.

For the instruction examples 4 to 6, the necessary hand tools, measuring and testing means and auxiliary accessories are specified to facilitate the preparation and execution of the work. Moreover, the previous knowledge, which is necessary in addition to knowledge of the technique of “manufacture of ceilings”, is also stated for each instruction example and should be recapitulated at the beginning.

Perspective and working drawings showing the required shapes and dimensions are attached to the instruction examples.

Instruction Example 4.1.: Calculation of Cross Sections of Wooden Beams

This example shall serve to practise the use of tables and the application of formulas for the calculation of wooden beam sections.

The cross sections of wooden beams for a ceiling of a warehouse building shall be calculated.

The wooden beam framing will be provided with a 30 mm thick flooring.

If the beam sections shown in the table are not available, other cross sections are to be proposed.

Auxiliary accessories

Paper, pencil, table No. 3 from the “Trainees’ Handbook of Lessons”, slide rule or calculator/computer

Necessary previous knowledge

Reading of tables, multiplication, division, raising to a power, extraction of roots

Sequence of operations	Comments
------------------------	----------

<p>1. Determine the beam section for a room of 3125 mm clear width.</p>	<p>Find out T_{zul} $T_{zul} = 1000$ mm Look for the size 3125 mm in column "w" of the table. If the size is not shown in the table, <u>round off to the next full decimetre.</u> Go to the right in line 3200 mm and read the beam section in the column "1000 mm".</p>
<p>2. Write down the reading of the beam section.</p>	<p>14/18 cm²</p>
<p>3. Determine the beam section for a room of 4635 mm.</p>	<p>Look for the size 4700 mm in column "w" of the table. Go to the right in line 4700 mm and read the beam section in the column "1000 mm".</p>
<p>4. Write down the beam section read.</p>	<p>22/22 cm²</p>
<p>5. Determine the beam sections for "replacement beams" – for 14/18 cm² beam section.</p>	<p>Formula $W_x = (b \cdot h^2)/6$ and $\text{formulah} = \sqrt{\frac{6 W_x}{b}}$ to be applied assuming a width of 100 mm and 120 mm.</p>
<p>Required: W_x $W_x = (b \cdot h^2)/6$</p>	
<p>$W_x = \frac{14 \text{ cm} \cdot 18^2 \text{ cm}^2}{3}$ Known: $b = 14$ cm $h = 18$ cm $W_x = 756 \text{ cm}^3$</p>	<p>This section modulus is to be maintained!</p>
<p>Required: h</p> <p>$h = \sqrt{\frac{6 \cdot W_x}{b}}$</p>	
<p>$h = \sqrt[3]{\frac{6 \cdot 756 \text{ cm}^3}{10 \text{ cm}}}$ Known: $W = 756$ cm³ $b = 10$ cm $h = 21.2$ cm</p>	
<p>Beam section <u>10/22 cm²</u></p>	
<p>Required: h ($b = 120$ mm)</p>	
<p>$h = \sqrt[3]{\frac{6 \cdot 756 \text{ cm}^3}{12 \text{ cm}}}$ Known: $W = 756$ cm³ $b = 12$ cm $h = 19.4$ cm</p>	
<p>Beam section <u>12/20 cm²</u></p>	
<p>– Beam section 22/22 cm²</p>	
<p>Required: W</p> <p>$W_x = \frac{b \cdot h^2}{6}$</p>	

$W_x = \frac{22 \text{ cm} \cdot 222 \text{ cm}^2}{6}$ <p>Known: $b = 22 \text{ cm}$ $h = 22 \text{ cm}$ $W_x = 1774.7 \text{ cm}^3$</p>	<p>assuming a width of 160 mm, 180 mm and 200 mm</p>
<p>Required: h</p> $h = \sqrt{\frac{6 \cdot W_x}{b}}$	
<p>Known: $W_x = 1774.7 \text{ cm}^3$</p> $h = \sqrt{\frac{6 \cdot 1774.7 \text{ cm}^3}{16 \text{ cm}}}$ <p>$b = 16 \text{ cm}$ $h = 25.7 \text{ cm}$</p>	
<p>Beam section <u>16/26 cm²</u></p>	
<p>Required: h ($b = 18 \text{ cm}$)</p>	
<p>Known: $W_x = 1774.7 \text{ cm}^3$</p> $h = \sqrt{\frac{6 \cdot 1774.7 \text{ cm}^3}{18 \text{ cm}}}$ <p>$b = 18 \text{ cm}$ $h = 24.3 \text{ cm}$</p>	
<p>Beam section <u>18/26 cm²</u></p>	
<p>Required: h ($b = 20 \text{ cm}$)</p>	
<p>Known: $W_x = 1774.7 \text{ cm}^3$</p> $h = \sqrt{\frac{6 \cdot 1774.7 \text{ cm}^3}{20 \text{ cm}}}$ <p>$b = 20 \text{ cm}$ $h = 23.07 \text{ cm}$</p>	
<p>Beam section <u>20/24 cm²</u></p>	

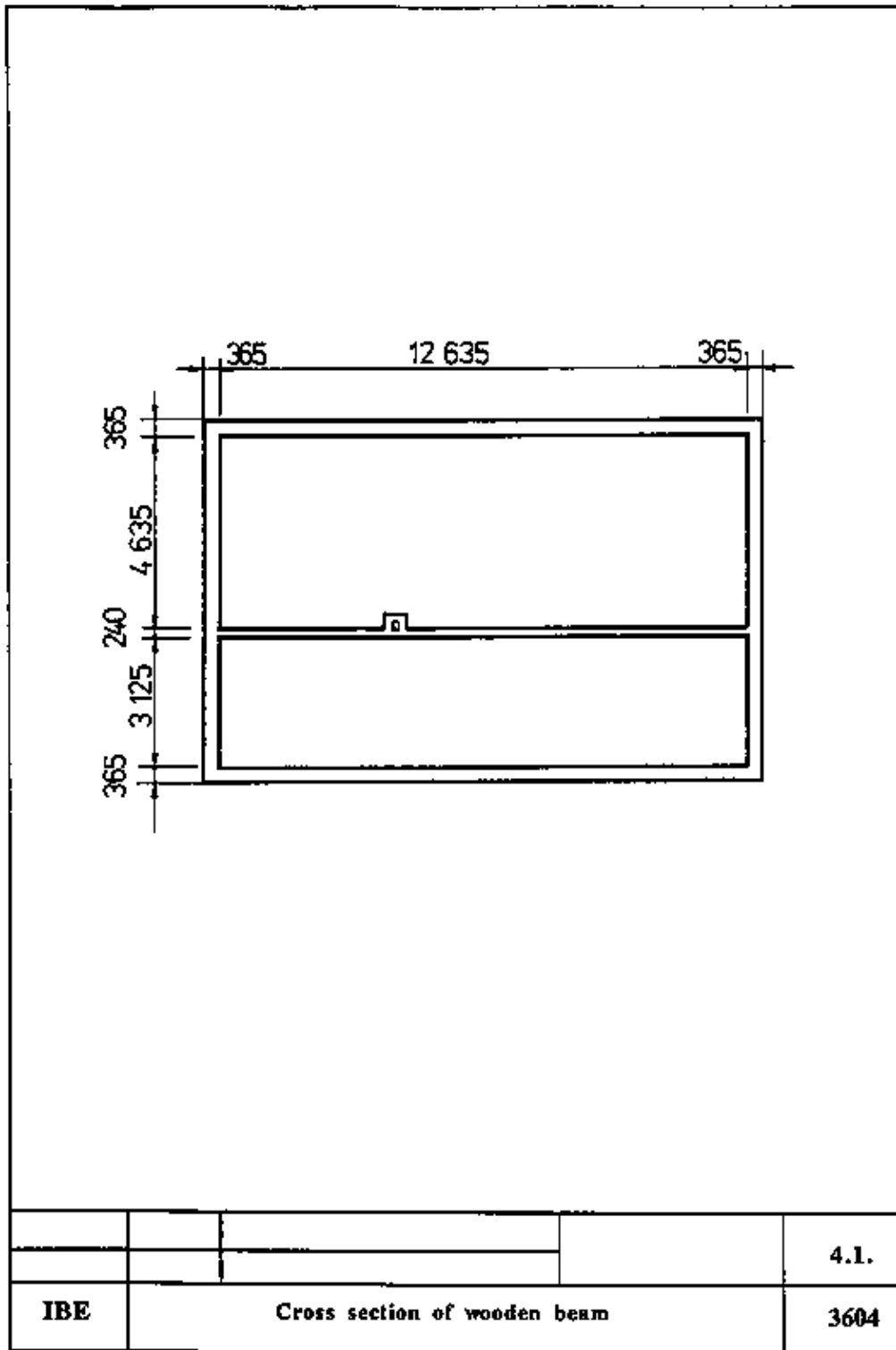

Cross section of wooden beam

Instruction Example 4.2.: Determination of the Pitch Size

The pitch size between the fixed joining beams for the roof framing shall be determined.

Assumed to be known:

- Beam section 180/180 cm²
- $T_{zul} = 800$ mm
- Joining beam distance = 4000 mm

Auxiliary accessories

Paper, pencil, slide rule or calculator/computer

Necessary previous knowledge

Addition, subtraction, multiplication, division

Sequence of operations	Comments
1. Determine the pitch size for the distance 1602.5 mm	
$T = \frac{L_r}{n'_F}$ Requ.: T	
$L_r = L - \frac{b_1 + b_2}{2}$ Known:	
$n_F = \frac{L_r}{T_{zul}}$	
$L = B - c$	
$b_1 = b_2 = 0 \text{ mm}$	
$T_{zul} = 800 \text{ mm}$	Between gable and joining beam because the size extends up to the front edge of the joining beam.
$B = 1602.5 \text{ mm}$	
$c = 20 \text{ mm}$	
$L = 1602.5 \text{ mm} - 20 \text{ mm}$ $L = 1582.5 \text{ mm}$	
$L_r = 1582.5 \text{ mm} - 0.0 \text{ mm}$ $L_r = 1582.5 \text{ mm}$	
$n_F = \frac{1582.5 \text{ mm}}{800.0 \text{ mm}} = 1.9 n'_F = 2$	
$T = \frac{1582.5 \text{ mm}}{2}$ $T = 791.25 \text{ mm}$	
2. Determine the pitch size for the distance 4000 mm	
$T = \frac{L_r}{n'_F}$ Requ.: T	
Known: $L_r = 4000 \text{ mm}$	Size extends from the front edge of the joining beam up to the front edge of the joining beam!
$n_F = \frac{L_r}{T_{zul}}$	

$T_{zul} = 800 \text{ mm}$	
$n_F = \frac{4000 \text{ mm}}{800 \text{ mm}} = 5 \quad n'_F = 5$	
$T = \frac{4000 \text{ mm}}{5}$ $T = 800 \text{ mm}$	
3. Determine the pitch size for the distance 1782.5 mm	
Requ.: T $T = \frac{L_r}{n'_F}$	
Known: $L_r = L - b_2$	$b_1 = 0.0 \text{ mm}$ because b_1 is within the distance. The size extends from the front edge of the joining beam up to the gable wall.
$n_F = \frac{L_r}{T_{zul}}$	
$L = B - c$	
$b_2 = 180 \text{ mm}$	The size extends from the front edge of the joining beam up to the gable wall.
$T_{zul} = 800 \text{ mm}$	
$B = 1782.5 \text{ mm}; c = 20 \text{ mm}$	
$L = 1182.5 \text{ mm} - 20 \text{ mm}$ $L = 1162.5 \text{ mm}$	
$L_r = 1162.5 \text{ mm} - 180 \text{ mm}$ $L_r = 982.5 \text{ mm}$	
$n_F = \frac{982.5 \text{ mm}}{800.0 \text{ mm}} = 1.23 \quad n'_F = 2$	
$T = \frac{982.5 \text{ mm}}{2}$	
$T = 491.25 \text{ mm}$	

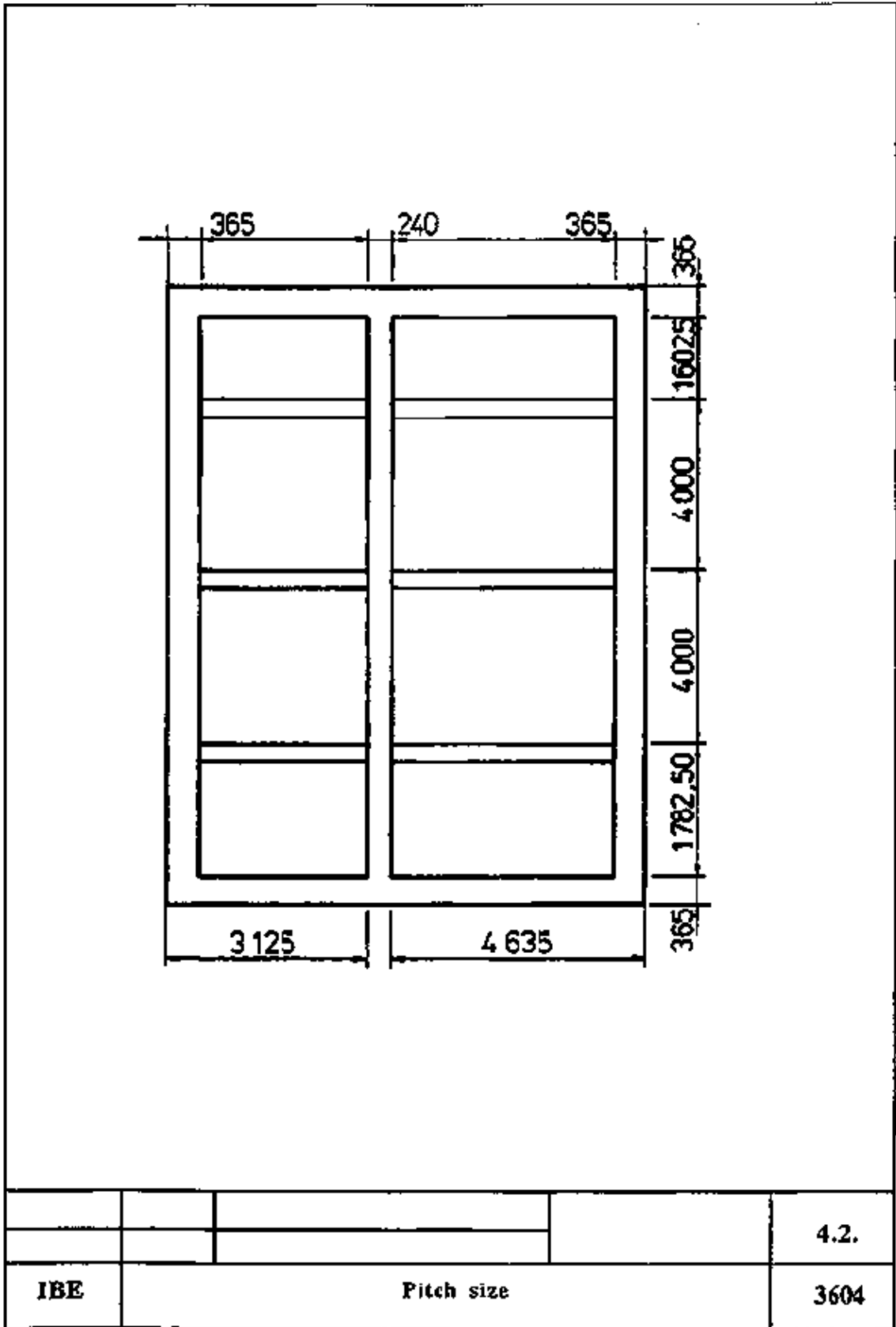

Pitch size

Instruction Example 4.3.: Preparation of a List of Timber

A list of timber for ordering wooden beams for the 2nd floor ceiling of a building of 10,990 mm length and 7,865 mm width shall be prepared.

Assumed to be known:

- Trimmer beam: 180/200 mm²
- Beam trimming: 180/200 mm²
- Filling timbers: 80/200 mm²

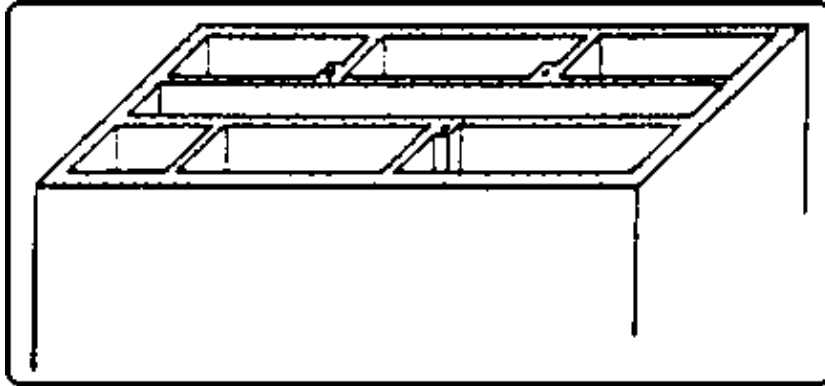

Auxiliary accessories

Form of list of timber, working drawing, paper, pencil, calculator/computer

Necessary previous knowledge

Reading of drawings, addition, subtraction, multiplication

Explanations to the form of list of timber

1 serial number, 2 quantity (pieces), 3 designation, 4 cross section in cm/cm, 5 individual length in mm, 6 m according to cross section of timber, 7 total length in m, 8 waste in %, 9 total length and waste, 10 volume in m³, 11 total volume in m³

List of timber for thefloor ceiling													
1	2	3	4	5	6								
				7									
				8									
				9									
				10									
				11									

Form for ordering of wood beams

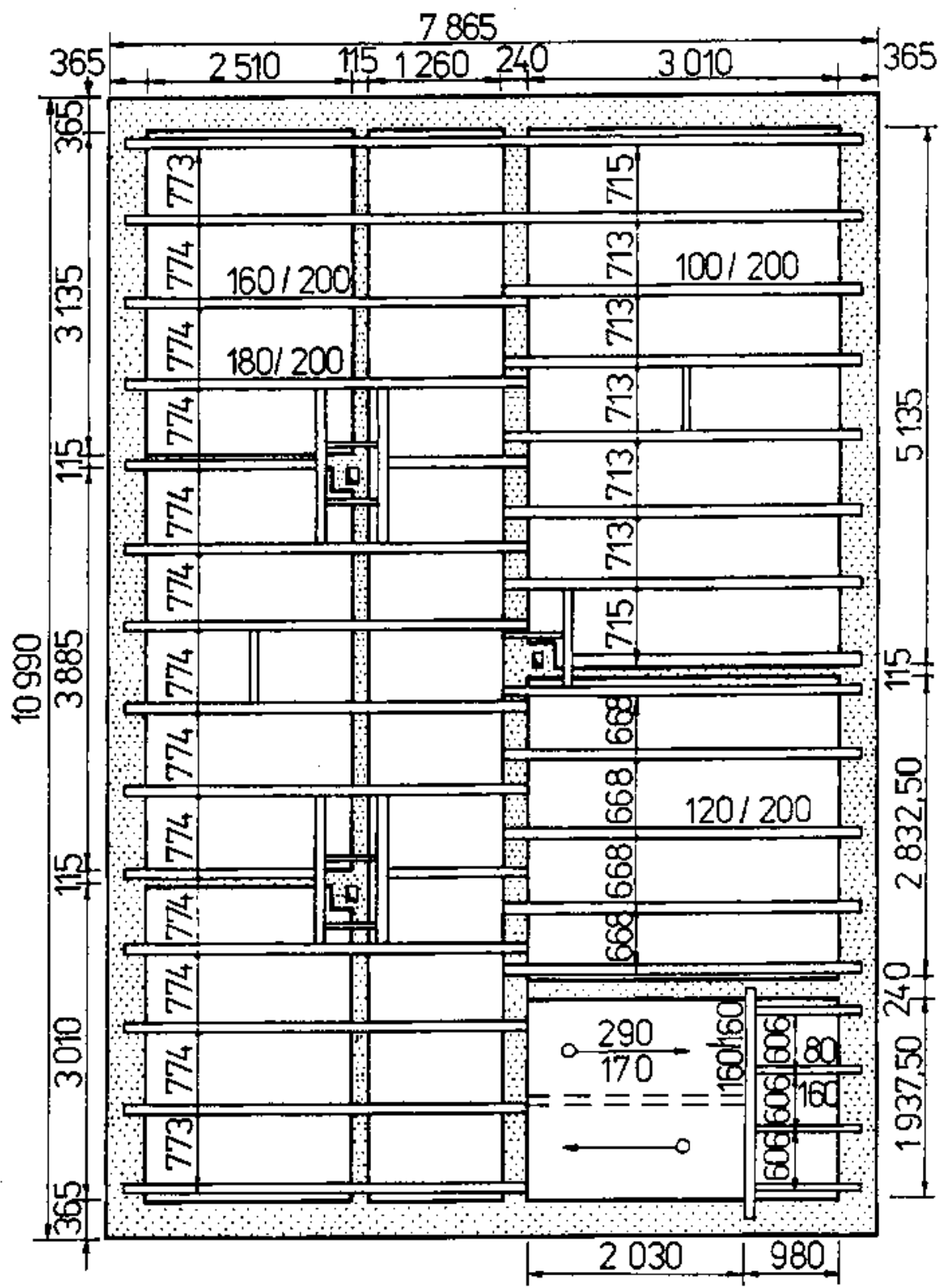

			4.3.
11 IBE	List of timber		3604

Instruction Example 4.4.: Preparation of the Wall Plate Bearing

The bearing to support the wall plate shall be made.

Assumed to be known:

- Height of the metre mark as per drawing 1450 mm
- Cross section of the wall plate timber 80/60 mm²
- Thickness of outer wall 365 mm
- Plaster base: 25 mm thick wood-wool board

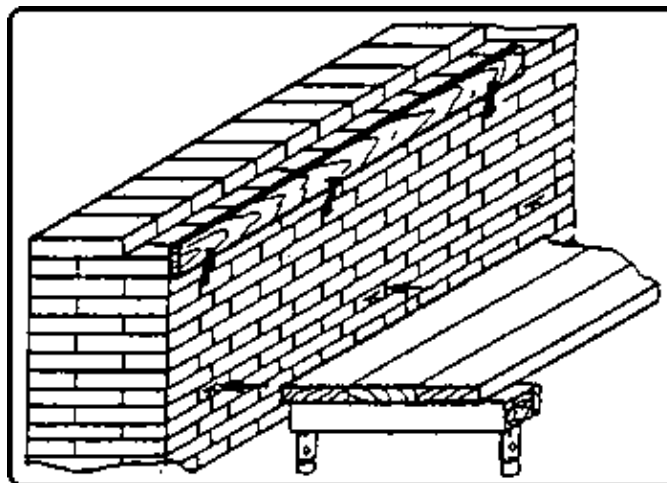

Hand tools

Hammer, trowel, float

Measuring and testing means

Folding rule, water level, measuring rod 1450 mm long

Auxiliary accessories

Levelling board, pencil, brackets, mortar, scaffolding

Necessary previous knowledge

Reading of drawings, measuring, levelling

Explanations to the working drawing

1 metre mark, 2 levelling board, 3 bracket, 4 scaffolding, 5 bearing for wall plates

Sequence of operations	Comments
1 Check the bearing height starting from the metre marks.	Scribe the measured size with pencil on the wall. Check on both outer walls.
2. Compare the biggest gauge size with the drawing for the respective building.	Find out any difference (starting from the biggest gauge size). If the brickwork is too high, remove one layer.

3. Hold the upper side of the levelling board flush with the bearing level and fix it to the wall by means of brackets.	Use measuring rod. Put on water level for checking.
4. Apply mortar up to the upper side of the levelling board.	The consistency of the mortar is important. (It should be easy to distribute but also set quickly)
5. Distribute the mortar.	Make sure that it is flush with the upper side of the levelling board.
6. Remove the brackets, take off the levelling board and reset it.	Take off the levelling board downwards! (Damage to the surface)
7. Repeat operations 4–6 above.	

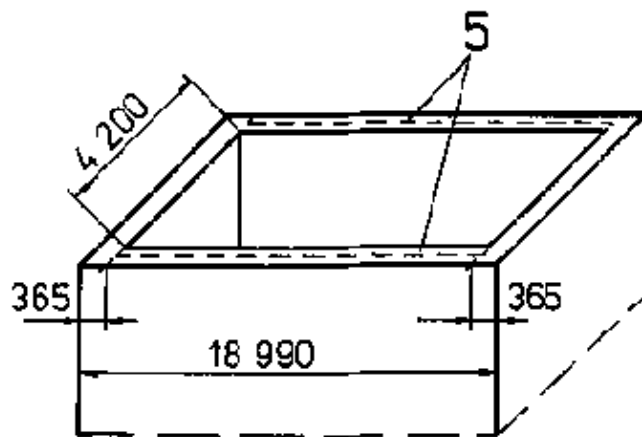
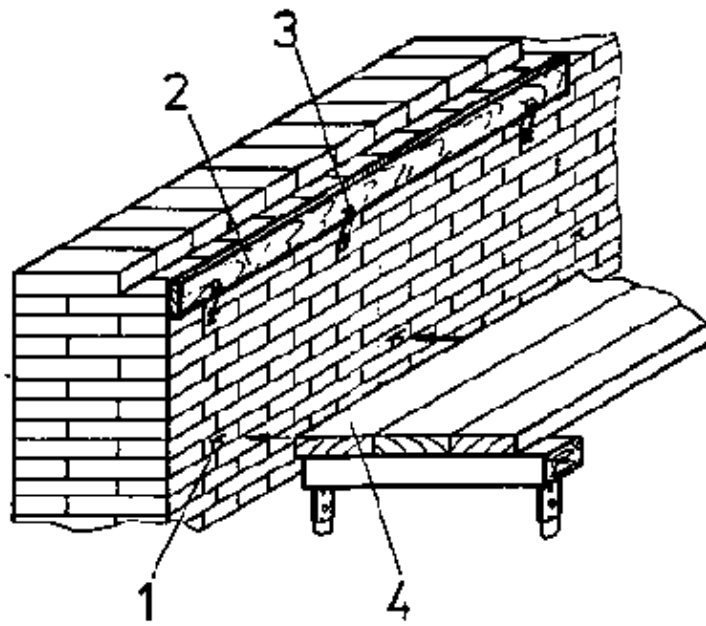

			4.4.
IBE	Wall plates		3604

Wall plates

Instruction Example 4.5.: Placing of Wall Plates

The wall plates for the wooden beam ceiling are to be prepared and placed.

Assumed to be known:

- Length of building = 18,990 mm
- Thickness of outer wall = 365 mm
- Wall plate section: 80/60 mm²
- Timber lengths for wall plates: 4000 mm
- Wooden beams are to be secured with pin connection

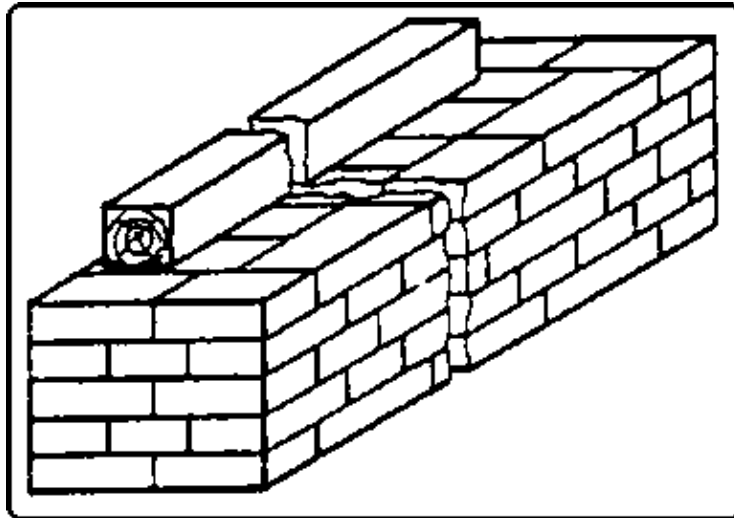

Hand tools

Hammer, hand saw, mortise chisel 20 mm, planing chisel 35 mm, axe

Measuring and testing means

Folding rule, water level, square, bricklayer's line, measuring tape

Auxiliary accessories

Pencil, inside scaffolding (at working level), trestles, barrier cardboard (building paper), nails 3.1/70

Necessary previous knowledge

Reading of drawings, measuring, scribing, sawing, mortising, plastering, aligning

Explanations to the working drawing

1 wall plates

Sequence of operations	Comments
1. Measure the clear width between the gables.	Use a measuring tape.
2. Determine the number of wall plates required for one side.	18,260 mm: 4000 mm = 4.5 which means: 5 wall plates for one side = totally 10 wall plates.
3. Place the trestles on the floor ceiling and put on 6 wall plates.	Inspect the wall plates and put slight camber at top.
4. Scribe half joints at both sides and prepare the wall plates.	Pay attention to jointing side. Use a square.
5. Remove the wall plates from the trestles and store them at the side.	Make sure that there is enough room to move (danger of accidents)!
6. Put the remaining 4 wall plates on the trestles and scribe and prepare half joints at one side.	Pay attention to camber and jointing side.

7. Cut strips of barrier card-board and put them on the bearing.	Strips must not project at the inside of the outer wall.
8. Place wall plates on one outer wall, join them and drive a nail into the halved joint.	Use correct nail length. One wall plate with half joint at one side and three wall plates with half joint at both sides.
9. Measure the difference at the bearing, transfer and scribe such size on the wall plate, saw off the wall plate.	Check the position of the wall plate at the other end! Place the wall plate flush with the inner wall of the gable.
10. Put on, join and nail the sawn off wall plate.	Drive in one nail.
11. Fix the line at both ends of the joined wall plates, tension it and align the wall plates.	Do not drive the line. Take into account the thickness of the plaster base.
12. Drive a second nail into the halved joints.	
13. Mount the wall plate at the opposite outer wall.	Repeat operations 7 to 12 above.

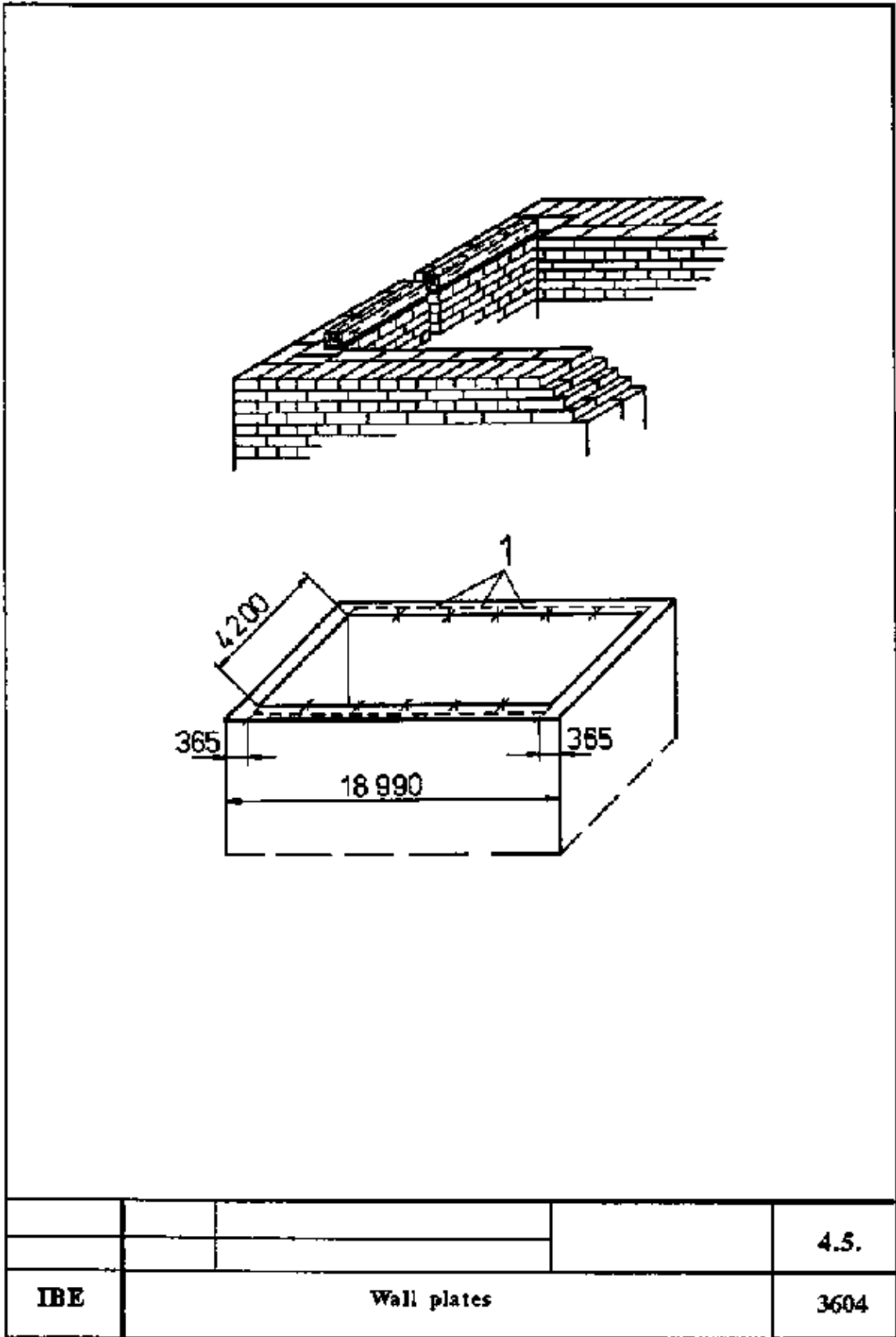

Wall plates

Instruction Example 4.6.: Preparation of the Wooden Beam Framing

A wooden beam framing shall be prepared over a room with a clear width of 12,635 mm.

Assumed to be known:

- 20 mm thick batten floor
- Wooden beam section: 120/200 mm²
- Wall plate section: 80/60 mm²
- Outer wall thickness: 365 mm
- Wooden beams are to be secured with a cogging at one end
- The bearing for the wall plates is already prepared

Hand tools

Hammer, hand saw, mortise chisel 24 mm, planing chisel 35 mm, axe

Measuring and testing means

Folding rule, measuring tape, square

Auxiliary accessories

Pencil, piece of board approx. 200 mm long and 120 mm wide (wooden beam width), approx. 4000 mm long lath, approx. 4750 mm long lath, trestles

Necessary previous knowledge

Measuring, scribing, sawing, mortising, plastering

Sequence of operations	Comments
1. Determine the pitch size.	$n'_F = 21$; $T = 594.0$ mm
2. Scribe pitch size on 4000 mm long lath.	Use a measuring tape. Add up the pitch size for scribing (e.g. 594 – 1188 – 1782 – 2376 – 2970 – 3564 (mm)). Scribe square lines.
3. Put four wall plates (quantity for one outer wall) on trestles, scribe a half joint at each end and prepare the half joints, remove the wall plates from the trestles and store them.	Take camber on top. Determine and mark the jointing side. Use a square. Make sure that there is enough room to move.
4. Put four wall plates on trestles and scribe a half joint at one end only, prepare the half joints.	Camber on top. Determine and mark the jointing side. Use a square.
5. Take two wall plates from the trestles and put on and number two of the wall plates worked at first.	I and IV: the wall plates with one half joint each, II and III: the wall plates with two half joints each. Number at the left-hand end.
6. Scribe wall marking on wall plate marked with I.	Scribe at the end with no half joint.
7. Put the lath with scribed pitch size on the wall plate, transfer the pitch size, scribe square lines and provide with jointing mark.	Scribe square lines from front edge to centre of wall plate only.
8. Leave lath on first wall plate, transfer scribed half joint to lath and mark with "1".	Put lath on top side of wall plate. Check faying at wall marking.
9. Scribe beam width on the first wall plate.	Use 120 mm wide piece of board, put it to the square and scribe from front edge to centre of wall plate.

10. Put lath on second wall plate, transfer pitch size, scribe square lines and provide with jointing mark.	Put lath on top side. Pay attention to “1” mark at half joint!
11. Leave lath on wall plate, scribe–mark half joint on lath and mark with “2”.	Check exact faying.
12. Scribe beam width on the second wall plate.	
13. Scribe wall plates III and IV.	Same sequence as per operations 9 to 11.
14. Transfer beam width from front edge of wall plate with square lines downwards and scribe cogging depth on surface of cogging width.	Scribe lines approx. 20 mm long only. Cogging depth approx. 2 cm.
15. Take wall plate from trestles and store it, put on the wall plates for the second outer wall and number them.	V an VIII: wall plates with one half joint each, VI and VII: wall plates with two half joints each.
16. Scribe wall plate similar to the first four ones.	Remove the “1”, “2”, “3” marks from the lath for the pitch size first.
17. Mortise the coggings on all wall plates.	Any order. Make sure that there is enough room to move.
18. Prepare lath (4750 mm long) for scribing of beam lines.	Cut lath to length. Lath length = 2 bearing lengths + clear width of room $L = 2 \cdot 200 \text{ mm} + 4200 \text{ mm}$ <u>$L = 4600 \text{ mm}$</u>
– Scribe length on lath. – Measure–in and scribe bearing length (inner edge of wall).	Mark scribed lines with “section mark”. Measure from “section mark” line to centre of lath. Mark lines with “iew”.
– Measure–in and scribe thickness of plaster base (rear edge of wall plate).	Measure from “iew” line to the end of the lath and mark with “rew” Mark “iew” with void marks!
– Measure–in and scribe wall plate width (front edge of wall plate).	Measure from “rew” line to lath end and mark with “few”.
– Measure–in and scribe cogging width (cogging line).	Measure from “few” line to centre of lath and mark with “cl”. Mark “few” with void mark. Pay attention to cogging width on wall plate.
19. Put five wooden beams on trestles, provide with jointing mark and number them.	Camber to be <u>at bottom!</u> Number at the same beam sides.
20. Put the beams so as to be approximately flush at one end and close together with the longitudinal sides.	Make sure that the jointing marks have the same direction.
21. Scribe square lines over all five beams at the left–hand end and mark with “section mark”.	Scribe section line inwards only as much as to provide all beams with a square section line.
22. Put lath on outer beam and scribe beam section and cogging.	Put lath flush with “section” line. Scribe all valid lines (“rew” and “cl”) of the lath on all five beams. Use a square.

23. Put lath on opposite outer beam and check scribed lines.	Put lath flush with “section” line for checking!
24. Measure–in, angle and scribe cogging depth at both beam sides.	Use a square. Cogging depth approx. 2 cm.
25. Work out the cogging.	
26. Remove beams from the trestles and store them.	Make sure that there is enough room to move!
27. Scribe and prepare the remaining beams, one after the other, according to operations 19. to 26.	Number from VI to XXII.

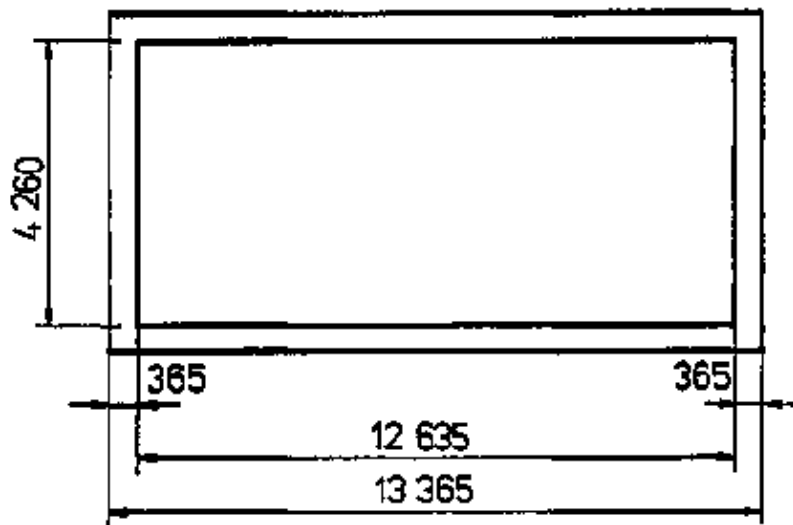
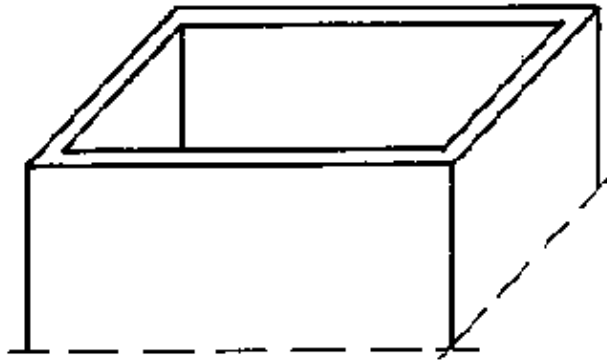

				4.6.
IBE	Wooden beam framing			3604

Wooden beam framing

