

[Home](#) > [ar.cn.de.en.es.fr.id.it.ph.po.ru.sw](#)

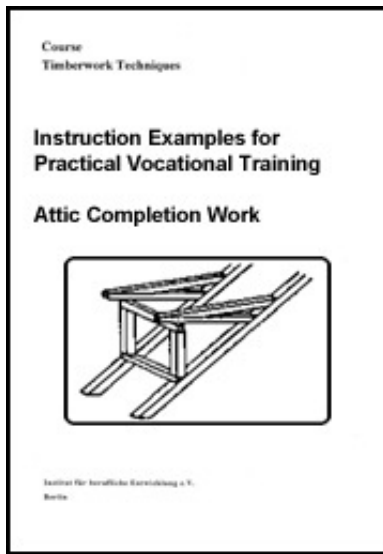

- ➔ **Attic Completion Work - Course: Timberwork techniques. Instruction examples for practical vocational training (Institut für Berufliche Entwicklung, 39 p.)**
- (introduction...)**
  - Preliminary Remarks**
  - Instruction Example 2.1.: Making Openings for Roof Superstructures in Existing Roofing**
  - Instruction Example 2.2.: Making a Rafter Trimming**
  - Instruction Example 2.3.: Making the Opening for the Roof Window to be Built in**
  - Instruction Example 2.4.: Joining of the Parapet Transom**
  - Instruction Example 2.5.: Joining of the Window Posts**
  - Instruction Example 2.6.: Joining of the Lintel Transom**
  - Instruction Example 2.7.: Joining of the String Transoms and Roof Rafters**









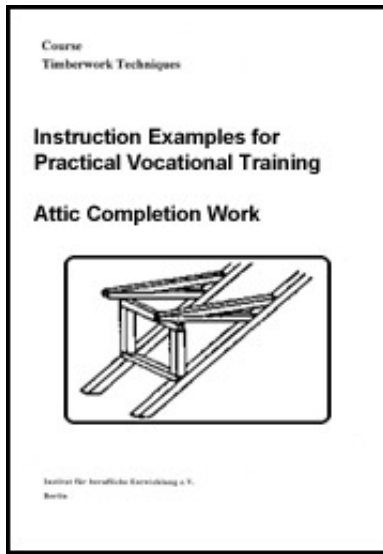

[Home](#) > [ar.cn.de.en.es.fr.id.it.ph.po.ru.sw](#)

- Attic Completion Work - Course: Timberwork techniques. Instruction examples for practical vocational training (Institut für Berufliche Entwicklung, 39 p.)**

➔ **(introduction...)**



-  **Preliminary Remarks**
-  **Instruction Example 2.1.: Making Openings for Roof Superstructures in Existing Roofing**
-  **Instruction Example 2.2.: Making a Rafter Trimming**
-  **Instruction Example 2.3.: Making the Opening for the Roof Window to be Built in**
-  **Instruction Example 2.4.: Joining of the Parapet Transom**
-  **Instruction Example 2.5.: Joining of the Window Posts**
-  **Instruction Example 2.6.: Joining of the Lintel Transom**
-  **Instruction Example 2.7.: Joining of the String Transoms and Roof Rafters**

**Institut für berufliche Entwicklung e.V.  
Berlin**

**Original title:**

**Lehrbeispiele für die berufspraktische Ausbildung  
"Herstellen von Dachausbauten"**

**Author: Rolf Becher**

**First Edition © IBE**

**Institut für berufliche Entwicklung e.V.  
Parkstraße 21-23**









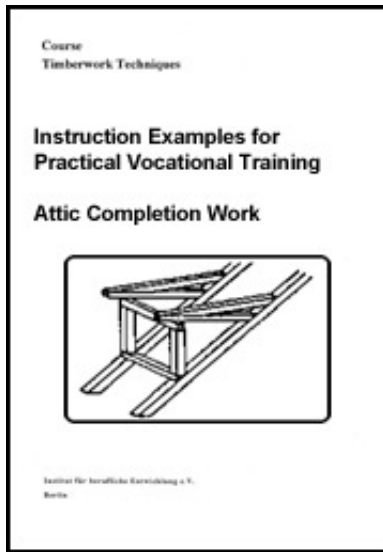

# 13187 Berlin

Order No.: 93-33-3602/2



[Home](#) > [ar](#).[cn](#).[de](#).[en](#).[es](#).[fr](#).[id](#).[it](#).[ph](#).[po](#).[ru](#).[sw](#)



-  **Attic Completion Work - Course: Timberwork techniques. Instruction examples for practical vocational training (Institut für Berufliche Entwicklung, 39 p.)**
-  **(introduction...)**
-   **Preliminary Remarks**
-  **Instruction Example 2.1.: Making Openings for Roof Superstructures in Existing Roofing**
-  **Instruction Example 2.2.: Making a Rafter Trimming**
-  **Instruction Example 2.3.: Making the Opening for the Roof Window to be Built in**
-  **Instruction Example 2.4.: Joining of the Parapet Transom**
-  **Instruction Example 2.5.: Joining of the Window Posts**
-  **Instruction Example 2.6.: Joining of the Lintel Transom**
-  **Instruction Example 2.7.: Joining of the String Transoms and Roof Rafters**

## Preliminary Remarks

**The present booklet contains 7 selected instruction examples to show the manual skills a carpenter must have and logical considerations he must make to meet the requirements of this trade.**

**The individual instruction examples have been selected so that they can be separately practised and carried out.**

**The Instruction Examples 2.3. to 2.7. are successively based on each other with the whole complex representing the entire technological flow for joining an upright window roofed with lean-to dormer.**

**The working drawings show the cross sections and lengths of timbers to be used by the trainees for the relevant steps of work.**

**Instruction Example 2.7. clearly explains how to calculate the real timber lengths and the recess sizes in the event of different roof pitches.**

**The logical sequence of the necessary steps of work is given in each instruction example and shown in the respective working drawings.**

**The hand tools, measuring and testing means, auxiliary accessories, as well as previous knowledge required are also mentioned.**



**[Home](#) > [ar](#).[cn](#).[de](#).[en](#).[es](#).[fr](#).[id](#).[it](#).[ph](#).[po](#).[ru](#).[sw](#)**



**Attic Completion Work - Course: Timberwork techniques.**

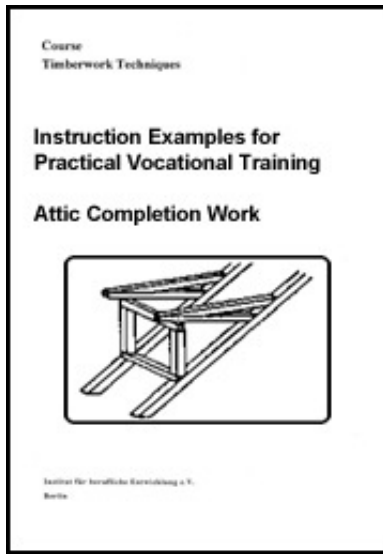

## Instruction examples for practical vocational training (Institut für Berufliche Entwicklung, 39 p.)

 **(introduction...)**

 **Preliminary Remarks**

 **Instruction Example 2.1.: Making Openings for Roof Superstructures in Existing Roofing**

 **Instruction Example 2.2.: Making a Rafter Trimming**

 **Instruction Example 2.3.: Making the Opening for the Roof Window to be Built in**

 **Instruction Example 2.4.: Joining of the Parapet Transom**

 **Instruction Example 2.5.: Joining of the Window Posts**

 **Instruction Example 2.6.: Joining of the Lintel Transom**

 **Instruction Example 2.7.: Joining of the String Transoms and Roof Rafters**

### Instruction Example 2.1.: Making Openings for Roof Superstructures in Existing Roofing

This instruction example explains how to saw out the openings for the roof window to be built in the existing roofing.

#### Constructional details

- **Gable roof as purlin roof with triple upright truss.**
- **Eaves angle: 45 degrees.**
- **Rafter distance: 800 mm.**

- **Roofing consisting of 24 mm thick boards with slating.**
- **Scaffolding is available at the facade.**

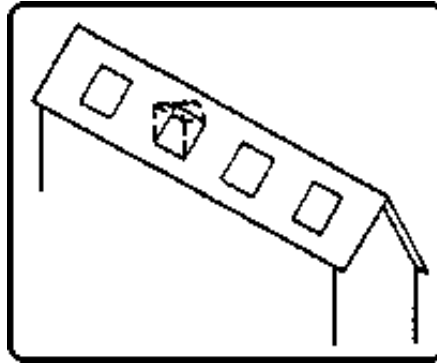

**Figure**

### **Hand tools**

**Hammer, hand saw, compass saw, pad saw, bit brace, insert bit of 20 mm diameter, carpenter's pincers**

**Measuring and testing means**

**Folding rule**

**Auxiliary accessories**

**Marking pencil, roofers' scaffolding, facade scaffolding, safety belt with catch rope**

**Necessary previous knowledge**

**Measuring, scribing, boring, sawing, functions of angles, reading of tabular values,**

## reading of drawings

### Explanations to the working drawing

#### 1 = area where the roofing is to be removed

##### Sequence of operations

1. Determine the sizes for the openings to be saw out and draw a hand sketch.
2. Check facade scaffolding for completeness and stability.
3. Measure-in and scribe on the existing roof face the lower horizontal limitation for removing the roof slates.
4. Measure-in and scribe the lateral limitation of the roof window opening.
5. Remove the roof slates above the lower limitation line.
6. Mount the roofer's scaffolding on

##### Comments

- See working drawing!
- Check covering of uprights for support.  
Check anchoring and bracing.
- Take the sizes from the hand sketch. Scribe with the marking pencil at one window only, starting from the centre of the roof window.  
Draw the scribed line at both sides beyond the trimmer rafters.
- Measure from the centre of the roof window. Start scribing about 100 mm below the lower horizontal limitation and continue until about 300 mm upwards.
- Remove the roof slates so that they can be used again.  
The outer edge of the trimmer rafter must be free of slates.
- Use scaffolding trestles with brushes.

the slate roof surface.

- |   |  |
|---|--|
| <p>7. Measure-in and scribe the upper horizontal limitation for removing the roof slates.</p>                 | <p>Work on the roofer's scaffolding with safety belt only.<br/>Fix catch rope to ladder hooks. Draw scribed line at both sides beyond the trimmer rafters (see working drawing for sizes).</p> |
| <p>8. Remove the slates up to the upper horizontal limitation of the opening.</p>                             | <p>Laterally the opening is limited by the trimmer rafters.</p>  |
| <p>9. Produce a borehole at the inside of the trimmer rafters below the upper limitation line.</p>            | <p>Use a 20 mm diameter bit to enable the compass saw to start. If possible, bore near a roof board joint.</p>   |
| <p>10. Saw out the first board with the compass saw.</p>  | <p>Guide the compass saw blade along the inside face of the trimmer rafter.<br/>Don't let the sawn-out board fall into the attic - danger of accidents!</p>                                    |
| <p>11. Saw out the roof boards up to the lower horizontal limitation using a pad saw and then a hand saw.</p> | <p>Guide the saw blade along the inside face of the trimmer rafter.</p>  |
| <p>12. Remove the roofers' scaffolding.</p>   |  |
| <p>13. Measure-in and scribe the limitation for the next opening.</p>   | <p>Measure from the centre of the first roof window. Repeat steps 3. through 12.</p>   |

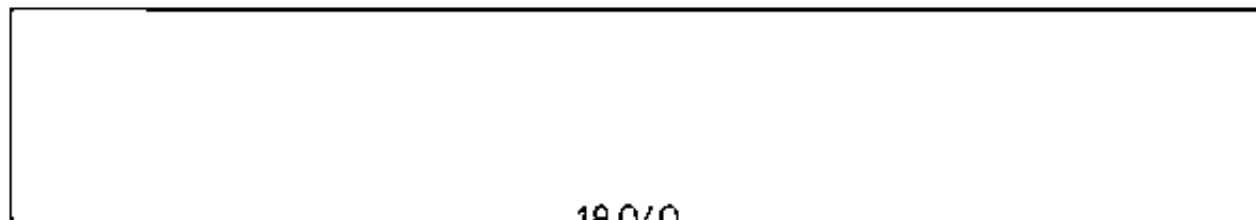

18/10



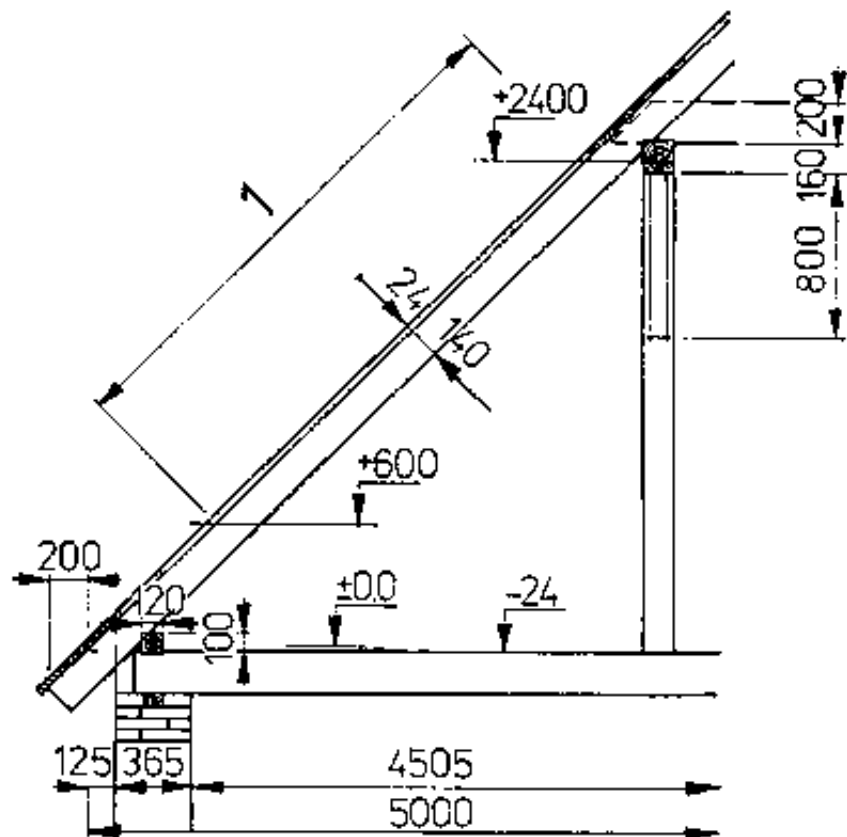
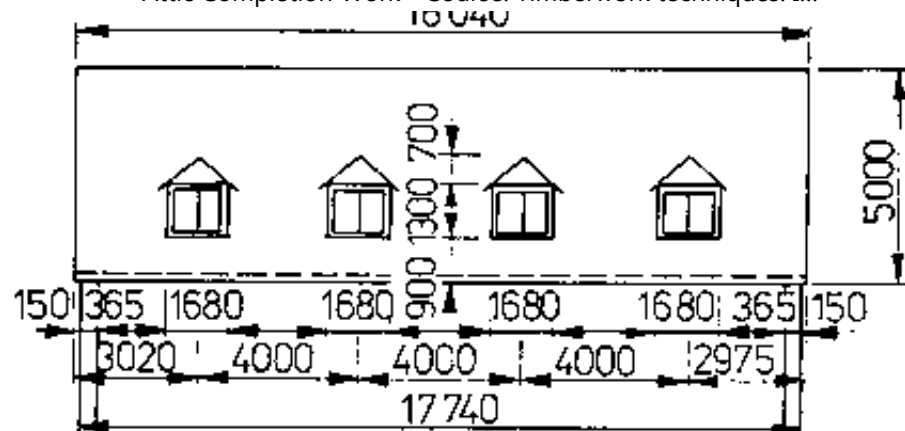









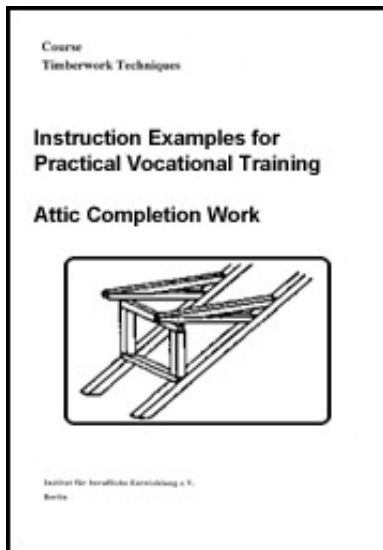



				2.1.
<b>IBE</b>	<b>Roof Superstructures</b>			<b>3602</b>

## Roof Superstructures



[Home](#) > [ar](#).[cn](#).[de](#).[en](#).[es](#).[fr](#).[id](#).[it](#).[ph](#).[po](#).[ru](#).[sw](#)



-  **Attic Completion Work - Course: Timberwork techniques. Instruction examples for practical vocational training (Institut für Berufliche Entwicklung, 39 p.)**
-  **(introduction...)**
-  **Preliminary Remarks**
-  **Instruction Example 2.1.: Making Openings for Roof Superstructures in Existing Roofing**
-   **Instruction Example 2.2.: Making a Rafter Trimming**
-  **Instruction Example 2.3.: Making the Opening for the Roof Window to be Built in**
-  **Instruction Example 2.4.: Joining of the Parapet Transom**
-  **Instruction Example 2.5.: Joining of the Window Posts**
-  **Instruction Example 2.6.: Joining of the Lintel Transom**
-  **Instruction Example 2.7.: Joining of the String Transoms and Roof Rafters**

## **Instruction Example 2.2.: Making a Rafter Trimming**

**This example teaches how to saw out the rafters of the main roof and build in the parapet trimmings in the area of the existing openings for upright roof windows to be built in, in order to make use of the attic.**

### **Constructional details**

- **Gable roof as purlin roof.**
- **Eaves angle: 45 degrees.**
- **Rafter distance: 800 mm.**
- **Parapet trimming to be joined with steel squares and hexagon-head wood screws. Tail rafter to be joined with mortise-and-tenon joint.**
- **Steel squares and hexagon-head wood screws to be supplied.**

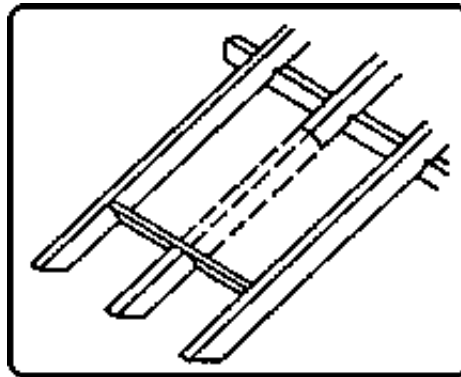

**Figure**

## **Hand tools**

**Hammer, hatchet, bit brace, insert bits of 6.2 mm and 3 mm, wrench with 10 mm opening, mortise chisel 24 mm, planing chisel 35 mm, beating wood**

## **Measuring and testing means**

**Folding rule, engineer's square, water-level**

## **Auxiliary accessories**

**Pencil, trestles, batten of 2200 mm length, cover strap of 700 mm length, 40 mm thickness and 120 mm width, cover strap of 700 mm length, 24 mm thickness and 120 mm width, 3.1/70 nails, 10/40 hexagon-head wood screws of diameter 6, clamp iron**

## **Necessary previous knowledge**

**Measuring, plumbing, scribing, boring, mortising, planing (smoothing), reading of drawings**

## **Explanations to the working drawing**

**The identification figures allocated to the arrows correspond to the numbers of the working steps in the working drawing.**

## **Sequence of operations**

1. Store the tools, auxiliary accessories and

## **Comments**

Do not store them in the immediate working

parapet trimmings in the attic.

2. Erect the trestles and put on the rafter trimmings.

3. Check the parapet trimmings, decide on the joining side and mark with marking-out mark.

4. Measure the clearance between the trimmer rafters.

5. Measure the clearance between the trimmer rafters and tail rafters to be produced.

6. Scribe section at left end of parapet trimming and mark with marking-out mark.

7. Measure-in, scribe and mark clearance between trimmer rafters, starting from the scribed section line towards the right.

8. Measure-in and scribe measured size between trimmer rafters and tail rafters, starting from the left scribed section line towards the right.

9. Measure-in and scribe mortise length from scribed line 8. towards the right.

10. Measure-in and scribe mortise width.

11. Transfer the scribed section lines at

area - danger of accidents!

Ensure stability of the trestles!

The joining side is the surface of the roof rafters.

Use the slight camber of the timber as joining side!

Use a sharp pencil and the engineer's square.

Place folding rule in parallel with parapet trimming and let folding rule tongues engage properly.

Scribe a thin line and place the engineer's square!

Measure from the joining side!

The scribed section lines must be congruent!

11. Transfer the scribed section lines at both ends of parapet transom onto all timber faces.

12. Place parapet transom on trestles so that face "1" is on top and then make the mortise.

13. Saw parapet trimming to length.

14. Place steel square on both sawn ends of parapet transom, scribe borehole of square and take off square.

15. Pre-bore holes of 3 mm diameter for screwing in the hexagon-head wood screws.

16. Put on steel square, place hexagon-head wood screw and screw it in by wrench.

17. Place folding rule perpendicularly on tail rafter to be produced and scribe 600 mm

THE SCRIBED SECTION LINES MUST BE CONGRUENT.

Ensure firm support on the trestles!

Select the trestle distance so as to prevent tilting-up of the parapet transom during mortising, otherwise there is the danger of accidents!

Saw exactly along the scribed pencil line!

Scribe one side first and then the other one.

Place water-level for alignment on cross-grain end of parapet transom and locate steel square flush.

Place water-level with flat side not perpendicular.

When placing water-level ensure complete contact!

Place bit on centre of scribed holes!

Do not overturn the hexagon-head wood screw when tightening it, otherwise the steel square will not fit snugly.

Place water-level for alignment of steel square before finally tightening the screws.

Scribe-mark exactly on bottom side of rafter!

size.

18. Scribe section.

19. Scribe tenon length and mark with marking-out mark.

20. Measure-in and scribe tenon thickness.

21. Nail cleat for stiffening of rafter to bottom side.

22. Determine and scribe inclination of cover strap (50 mm thick) for stiffening of rafter and tack cover strap (24 mm thick) with its end face.

23. Place cover strap for stiffening, scribe face and length and prepare cover strap.

24. Place the prepared cover strap (50 mm thick) under the rafter with one end to contact the cleat and the faced end on the floor. Loosen the tacked cover strap (24 mm thick), shift it to the faced end, drive it towards the eaves angle and nail it on.

25. Nail 24 mm cover strap firmly.

26. Place the 2200 mm batten

Use engineer's square and scribe thin line!

Tenon length - engineer's square width, measure towards roof ridge!

Measure from surface of rafter downwards!

Saw off cleat of approx. 200 mm length from cover strap (24 mm thick)!

Nail cleat so as to avoid interference when working the tenon! Drive in three 3.1/70 nails!

Inclination of about 55 degrees is equal to a ratio of 1 (horizontal) : 1.33 (vertical).

Do not nail but just tack the cover strap (24 mm thick)!

Do not pull out the tack-nail off the cover strap!

Put one foot on the cover strap when driving so that it cannot spring back!

Do not hammer over the cover strap when driving -danger of injury!

Drive in three 3.1 mm diameter nails, 70 mm shank length (nails 3.1/70).

Use a water-level!

perpendicularly on the floor contacting the rafter on top. Plumb the batten and scribe the height line on the rafter.

27. Continue the height-line scribing horizontally up to the lower edge of the rafter.

28. Scribe the section line and mark it with marking-out mark.

29. Saw out the rafter.

30. Produce tenon on tail rafter.

31. Plug on parapet trimming with mortise on tenon of tail rafter, hammer and secure it against turning off.

32. Align parapet trimming and bore holes through boreholes in screwed-on steel square into one of the two trimmer rafters for screwing-in of hexagon-head wood screws.

33. Place hexagon-head wood screws and

Use the engineer's square for scribing!  
Transfer the section line to all four faces of the rafter!

Saw through on top at first strictly following the scribed line! When the lower end is being sawn through, it is absolutely necessary that a second worker secures the rafter piece to be sawn out against turning off, otherwise there is a great danger of accidents.

Secure by means of clamp iron. Do not fully drive in clamp iron jaws into the wood to avoid splitting of wood!

Use 3 mm diameter bits!

Do not overturn hexagon-head wood screws



screw them in by means of wrench.

34. Bore holes in the other trimmer rafter, place hexagon-head wood screws and screw them in by means of wrench.

when tightening

Before boring, press parapet trimming again towards eaves angle and keep pressing when boring.

35. Complete stiffening of roof rafter, nail cover straps completely, clear working place and prepare for next roof superstructure, place hexagon-head wood screws and screw them in by means of wrench.

Repeat steps 2. through 34!

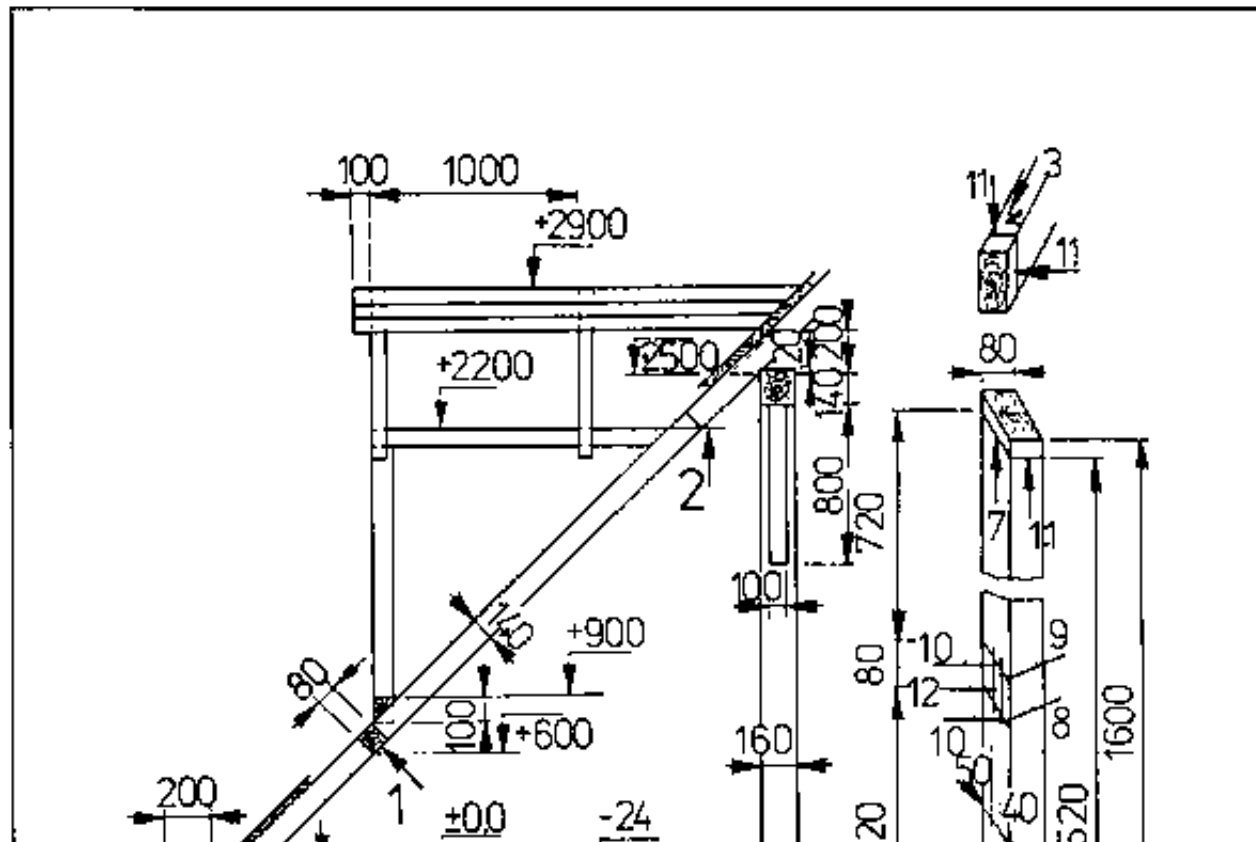

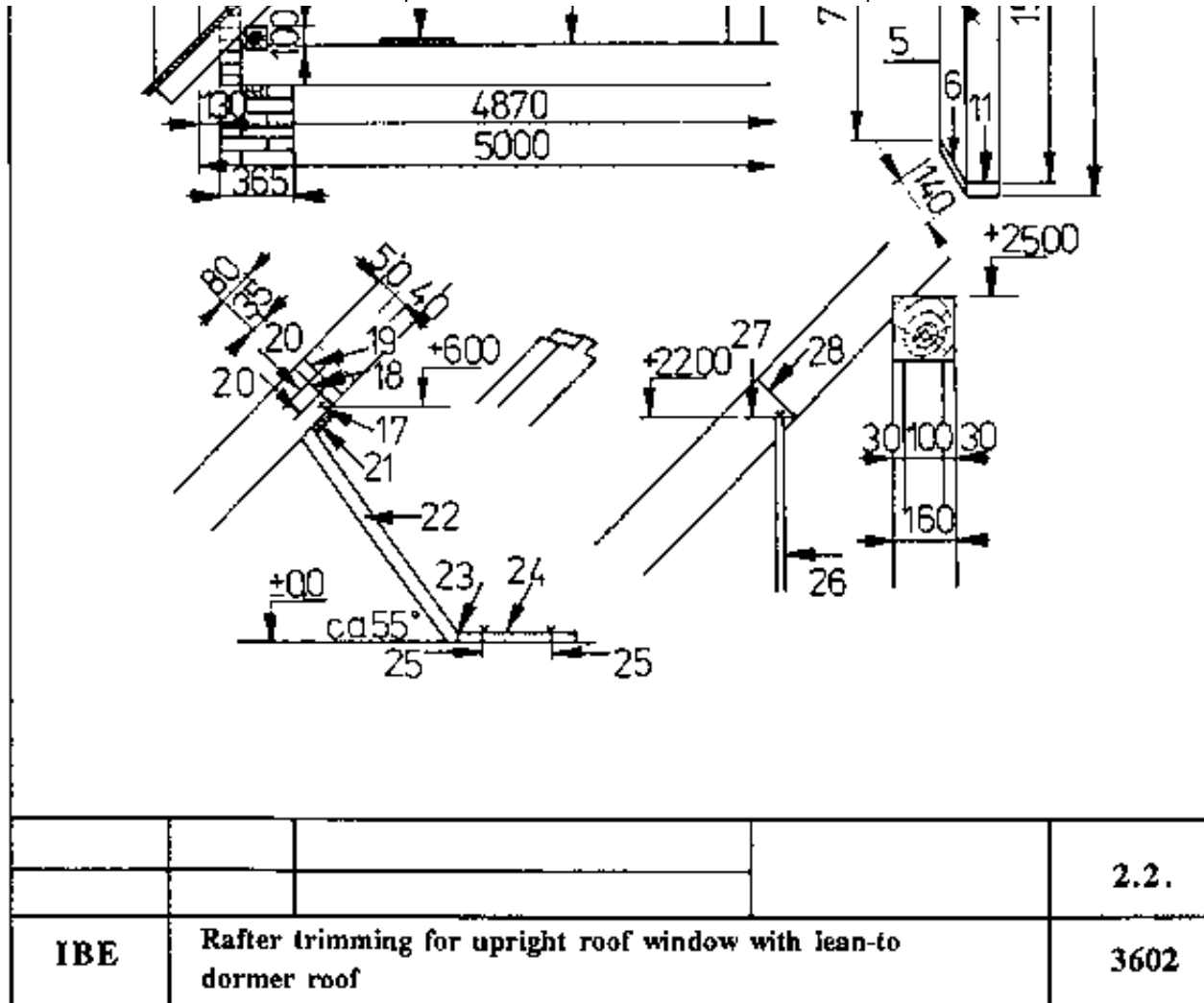

### Rafter trimming for upright roof window with lean-to dormer roof



[Home](#) > [ar](#) [cn](#) [de](#) [en](#) [es](#) [fr](#) [id](#) [it](#) [ph](#) [po](#) [ru](#) [sw](#)

 **Attic Completion Work - Course: Timberwork techniques.**

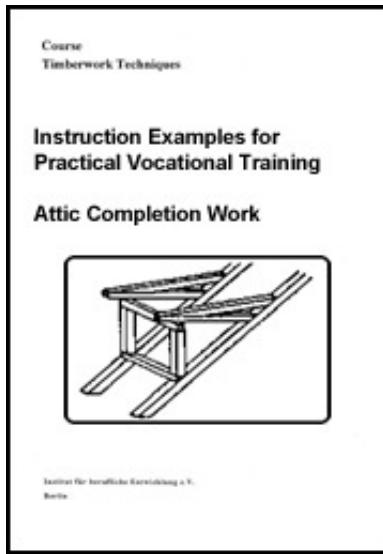

## Instruction examples for practical vocational training (Institut für Berufliche Entwicklung, 39 p.)

 **(introduction...)**

 **Preliminary Remarks**

 **Instruction Example 2.1.: Making Openings for Roof Superstructures in Existing Roofing**

 **Instruction Example 2.2.: Making a Rafter Trimming**

 **Instruction Example 2.3.: Making the Opening for the Roof Window to be Built in**

 **Instruction Example 2.4.: Joining of the Parapet Transom**

 **Instruction Example 2.5.: Joining of the Window Posts**

 **Instruction Example 2.6.: Joining of the Lintel Transom**

 **Instruction Example 2.7.: Joining of the String Transoms and Roof Rafters**

### **Instruction Example 2.3.: Making the Opening for the Roof Window to be Built in**

**This instruction example teaches how to make the opening in the existing roofing for the upright roof window with lean-to dormer roof to be built in.**

#### **Constructional details**

- **Gable roof as valley-beam (collar-beam) roof.**
- **Eaves angle: 45 degrees.**
- **Rafter distance: 820 mm.**
- **Upper edge of head rail: 2200 mm.**

- **Roofing consisting of 24 mm thick roof boards and two layers of roofing felt.**
- **Scaffolding is available at the facade.**

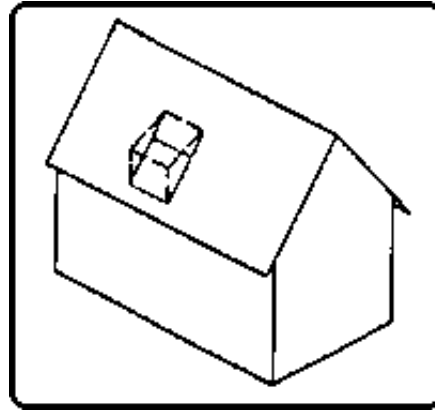

**Figure**

### **Hand tools**

**Hammer, hand saw, compass saw, pad saw, bit brace, insert bit of 20 mm diameter, carpenter's pincers, knife**

### **Measuring and testing means**

**Folding rule, water-level**

### **Auxiliary accessories**

**Marking pencil, battens of about 800 mm and 2300 mm length, straight-edge, safety belt with catch rope, 3.1/70 nails, ladder battens - 10 pcs.**

## Necessary previous knowledge

### Measuring, plumbing, scribing, boring, sawing, reading of drawings

#### Sequence of operations

1. Make available the necessary tools and materials.
2. Saw to length short batten to 750 mm and long batten to 2200 mm.
3. Find out in the attic the rafters where to build in the roof superstructure.
4. Place short batten perpendicularly on the floor leaning to the rafter on top and shift it towards the eaves angle.
5. Scribe marking-out line on roof boarding.
6. Scribe height line on opposite rafter.
7. Place nail on scribed line and drive it through the roofing from the inside to the outside.
8. Place long batten perpendicularly on the floor and scribe upper limitation of

#### Comments

- Secure tools and materials against falling down from the roof.
- Saw the two battens at right angles!
- Take size from the drawing!
- Use water-level! Place water-level to ensure perpendicularity when shifting the batten towards the eaves angle! Shift batten up to the roof bearding!
- Repeat steps 4. and 5!
- Make sure that the nail is long enough to penetrate at the outside roofing!  
Place nail as close at the rafter as possible.  
Repeat this at the neighbouring rafter.
- Similarly to steps 4. through 7.

## the opening

9. Check facade scaffolding including safety measures for completeness and stability.

10. Locate straight-edge at driven-through nails and scribe lower limitation of opening.

11. Locate straight-edge for lateral limitation at the driven-through nails and drive in tack-nail.

12. Nail ladder battens onto roofing at a distance of about 500 mm.

13. Scribe lateral limitation of the opening.

14. Loosen and remove straight-edge.

15. Locate straight-edge at opposite side and scribe lateral limitation.

16. Drive nails for opening limitation back.

Check anchoring or bracing and upright covering support.

Check safety fence, particularly for foot board!

Locate the straight-edge so as to scribe the limitation of the opening greater by the straightedge width. Use marking pencil.

Drive in tack-nail to prevent the straight-edge from slipping off! Do not drive in the nail completely because it has to be pulled out again!

Nail on ladder battens outside the opening to be made at a distance of about 100 mm from the tacked straight-edge!

Nail length should equal at least 2 times the thickness of the ladder batten!

Use the safety belt and fix the catch rope to the ladder hooks!

Scribe greater by the straight-edge width!

Pull out nail with hammer pane!

Pull out nail just as much as to permit the straightedge to be removed!

Proceed similarly to steps 11. through 14.

Just drive back nails, do not pull them out!

17. Loosen and remove roofing felt between the scribed marking-out lines. Guide the knife along the scribed lines and cut the roofing felt through!  
Pull out with pincers any felt nails left in the roof boarding!  
Do not throw the removed roofing felt from the scaffolding!
18. Bore a hole at the inside of the roof rafter below the upper limitation nail. Use 20 mm diameter bit to enable the compass saw to start!  
Bore close to a roof board joint, if possible!  
Do not bore into the driven-in nail! Use the safety belt!
19. Bore a hole at the neighbouring roof rafter. Repeat step 18.!
20. Saw out the first board using the compass saw. Guide compass saw blade along the inside face of the rafter!  
Do not let the sawn-out board fall into the attic!
21. Saw out the roof boards up to the lower horizontal limitation of the opening using a pad saw and hand saw. Guide the saw blade along the inside face of the rafter!  
Do not let the boards fall into the attic!
22. Clear the working place. Store the sawn-out boards in the attic. Pull out driven-in or left roofing felt nails!  
Remove the cut out roofing felt from the scaffolding but do not throw it off!  
Do not remove the ladder battens, they can be

used for building in the upright roof window!

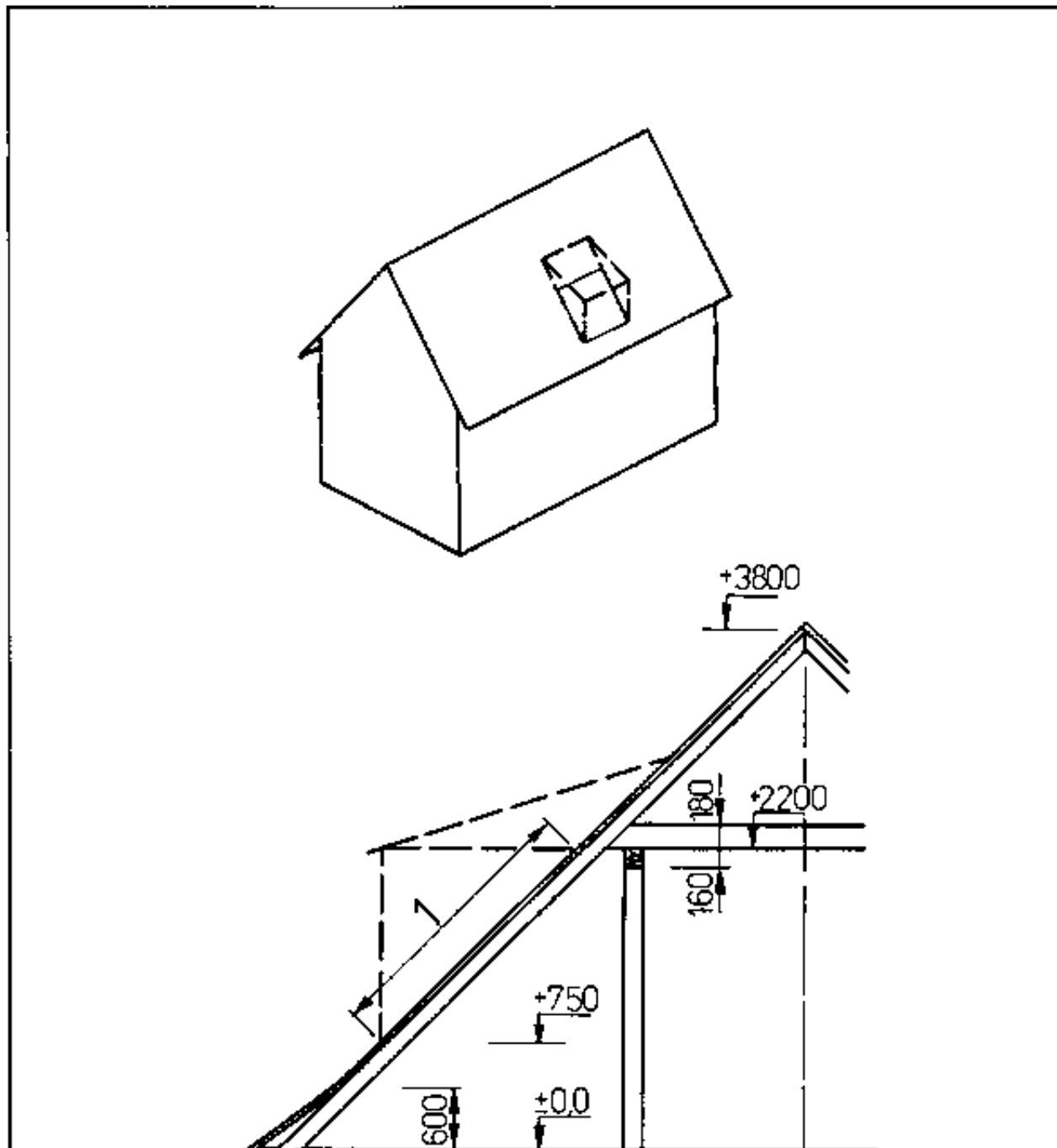



			2.3.
<b>IBE</b>	<b>Opening in roofing for roof window to be built in</b>		<b>3602</b>





### Opening in roof window to be built in

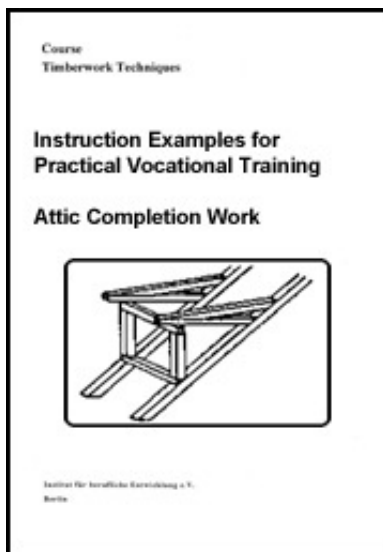





[Home](#) > [ar.cn.de.en.es.fr.id.it.ph.po.ru.sw](#)



## **Attic Completion Work - Course: Timberwork techniques. Instruction examples for practical vocational training (Institut für Berufliche Entwicklung, 39 p.)**

-  **(introduction...)**
-  **Preliminary Remarks**
-  **Instruction Example 2.1.: Making Openings for Roof Superstructures in Existing Roofing**
-  **Instruction Example 2.2.: Making a Rafter Trimming**
-  **Instruction Example 2.3.: Making the Opening for the Roof Window to be Built in**

- ➔  **Instruction Example 2.4.: Joining of the Parapet Transom**  
 **Instruction Example 2.5.: Joining of the Window Posts**  
 **Instruction Example 2.6.: Joining of the Lintel Transom**  
 **Instruction Example 2.7.: Joining of the String Transoms and Roof Rafters**

## **Instruction Example 2.4.: Joining of the Parapet Transom**

**This instruction example teaches how to join the parapet transom for an upright roof window with lean-to dormer roof.**

### **Constructional details**

- **The opening in the roofing has already been made.**
- **Window posts are to be joined with a corner tenon.**
- **Cross sections of timbers are shown in the workshop drawing on page 7.**
- **Parapet transom is just cut to the length of 950 mm.**

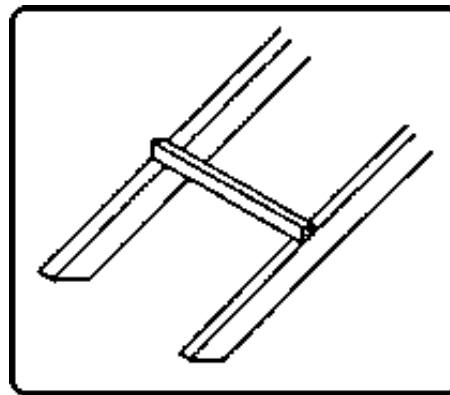

**Figure**

## **Hand tools**

**Hammer, engineer's square**

**Measuring and testing means**

**Folding rule**

**Auxiliary accessories**

**Trestles (one ell), pencil, marking gauge, workshop drawing**

**Necessary previous knowledge**

**Measuring, scribing, angling, use of marking-out marks, reading of drawings**

**Explanations to the working drawing**

**(D sectional view A-A, (2) upright roof window - front view.**

**The figures 1 to 12 represent the steps as per sequence of operations.**

### **Sequence of operations**

1. Manufacture a marking gauge.
2. Erect the trestles and prepare the working place.

### **Comments**

See working drawing point VII.  
Make sure that the recess sizes (35 mm, 70 mm) are sawn out at right angles!  
Ensure firm standing and stability of the trestles!

3. Put the parapet transom on the trestles, decide on the joining side and mark it.

4. Scribe the section line at the left end of the parapet transom and mark with marking-out mark.

5. Measure-in and scribe parapet transom length, starting from the section line and measuring to the right, mark with marking-out mark.

6. Measure-in and scribe at left and right section the window post width towards the centre.

7. Measure-in and scribe the comer tenon width from the two scribed lines towards the two ends of the parapet transom.

8. Scribe the tenon thickness.

9. Scribe section line on all four sides at the two ends

Store timbers, which are not required, outside the working area!  
Joining side III shall have a flat face!

If the timber is slightly cambered, take that camber on top (VI)!

Go only as far to the right as to permit a right-angle section to be produced!

Use engineer's square and scribe a thin line!

Use engineer's square and scribe a thin line!

Use engineer's square.

Use engineer's square and don't scribe over the total timber width!

Use marking gauge and scribe with sharp pencil exactly at marking gauge end face (VIII)!  
Do not cant marking gauge when scribing!

Use engineer's square. The scribed

of the parapet transom and mark with marking-out mark.

10. Scribe roof rafter inclination of main roof and mark with marking-out mark.

11. Measure-in, scribe and mark with marking-out mark the rafter width of the main roof on the side (V) opposite the joining side.

12. Transfer rafter width line to bottom side (IV) and mark with marking-out mark.

13. Work parapet transom accordingly, take it off the trestles and store it outside the working area.

section lines of all timber sides must be congruent!

If section lines are not congruent, find out the reasons:

- Engineer's square not correctly placed.

- Faulty square.  
Place square legs for scribing and exactly scribe the diagonal.

Use engineer's square and place it exactly!

Place engineer's square exactly.

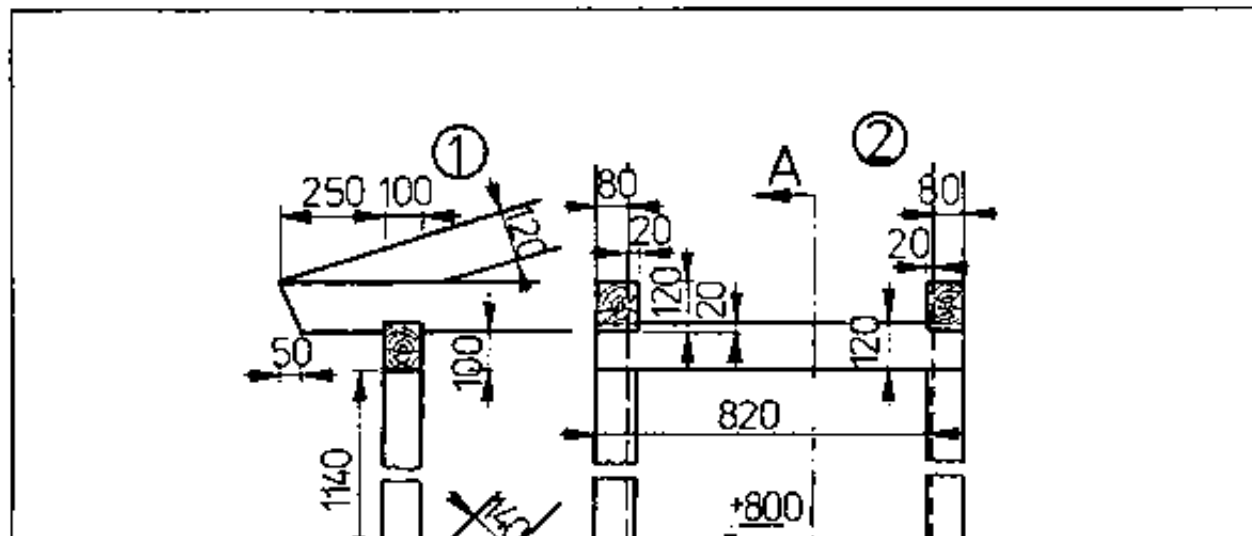

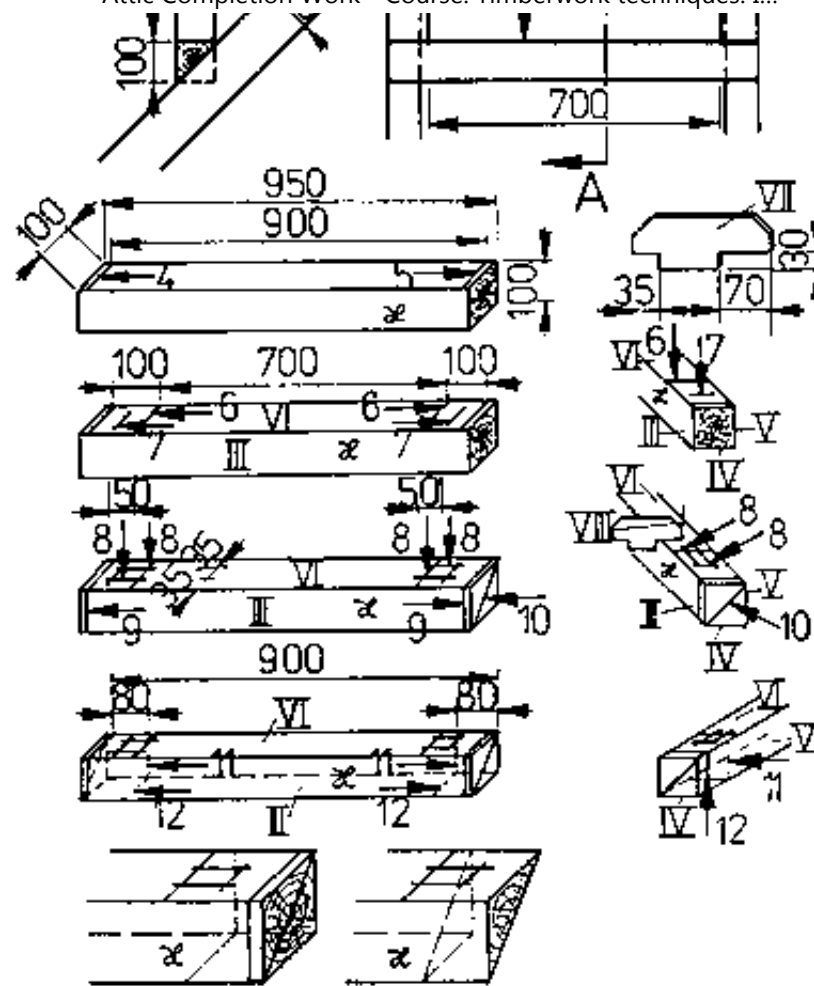









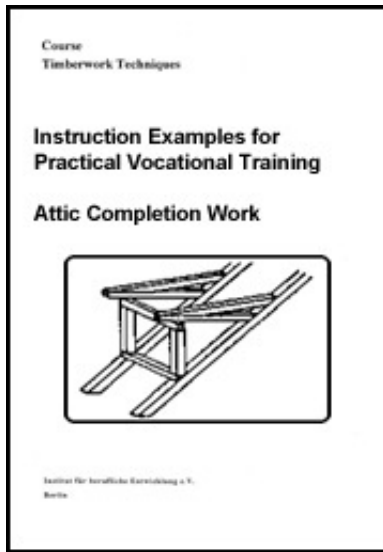

			2.4.
<b>IBE</b>	<b>Joining of the parapet transom</b>		<b>3602</b>

### Joining of the parapet transom



[Home](#) > [ar](#).[cn](#).[de](#).[en](#).[es](#).[fr](#).[id](#).[it](#).[ph](#).[po](#).[ru](#).[sw](#)



-  **Attic Completion Work - Course: Timberwork techniques. Instruction examples for practical vocational training (Institut für Berufliche Entwicklung, 39 p.)**
-  **(introduction...)**
-  **Preliminary Remarks**
-  **Instruction Example 2.1.: Making Openings for Roof Superstructures in Existing Roofing**
-  **Instruction Example 2.2.: Making a Rafter Trimming**
-  **Instruction Example 2.3.: Making the Opening for the Roof Window to be Built in**
-  **Instruction Example 2.4.: Joining of the Parapet Transom**
-  **Instruction Example 2.5.: Joining of the Window Posts**
-  **Instruction Example 2.6.: Joining of the Lintel Transom**
-  **Instruction Example 2.7.: Joining of the String Transoms and Roof Rafters**

## Instruction Example 2.5.: Joining of the Window Posts

**This instruction example teaches how to join the window posts for an upright roof window with lean-to dormer roof.**

## Constructional details

- The opening in the roofing has already been made.
- Window posts are to be joined with corner tenons.
- Cross sections of timbers are shown in the workshop drawing on page 7.
- Window posts are cut to a length of 1250 mm.

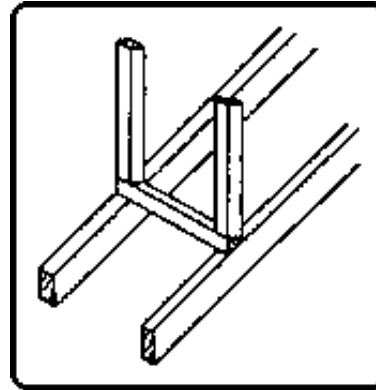

**Figure**

### Hand tools

**Hammer, engineer's square**

**Measuring and testing means**

**Folding rule**

**Auxiliary accessories**

**Trestles (one ell), pencil, marking gauge, workshop drawing**



## Necessary previous knowledge

**Measuring, scribing, angling, use of marking-out marks, reading of drawings**

**Explanations to the working drawing**

**The figures 2 to 14 represent the steps as per sequence of operations**

### Sequence of operations

1. Prepare the working place, erect the trestles with the correct distance.
2. Inspect the window posts, decide on the joining side and mark with marking-out mark.
3. Put the window posts closely together on the trestles.
4. Scribe section lines at left ends of window posts and mark with marking-out mark.
5. Angle the section line at both joining sides, scribe and mark-out.
6. Measure-in and scribe window post length.

### Comments

- Check the trestles for firm standing and stability!
- Joining side "I" shall have an even face! Any slight camber is to be used as outside face of the window post and to be marked with "II".
- Put them so that the face marked with "II" is visible from above!  
Place the joining sides so that they remain visible (see V)!  
Hammer with gentle hammer blows so that the left ends of the timbers are about flush!
- Go only as far to the right as to permit a right-angle section to be produced!
- Use engineer's square!
- Window post length = clear window height

starting from the section line and measuring to the right, and mark with the marking-out mark.

7. Angle the section line at right ends of window posts at the joining sides, scribe and mark-out.

8. Measure-in and scribe the corner tenon length at both section ends on timber face "II", measuring towards the centre.

9. Angle and scribe corner tenon length at the two joining sides.

10. Move the window posts apart because now each of them is to be separately scribed.

11. Scribe the corner tenon thickness at the left ends of the window posts.

12. Scribe the corner tenon thickness at the right ends of the window posts.

13. Measure-in and scribe corner tenon width.

14. Mark wood to be sawn out at all four corner tenons.

plus two tenon lengths!

Use engineer's square and place it exactly!

Clear window height is shown in Instruction Example 2.4!

Use engineer's square!

Scribed line must be in parallel with scribed line of steps 4. and 6. above!

Place engineer's square exactly and scribe thin line!

Select the distance so that scribing between the timber faces marked with "III" is possible without hindrance!

Place sharp pencil exactly at marking gauge end face and scribe from the joining side!  
Do not cant the marking gauge when scribing!

See step 11. above!

Scribed line must be in parallel with timber face "II"!

Scribe crossing diagonal lines!

15. Angle the section lines at both ends of the window posts onto the timber faces "III" and "IV", scribe and mark with marking-out mark.

16. Work the window posts.

17. Take the worked window posts off the trestles and store them outside the working area.

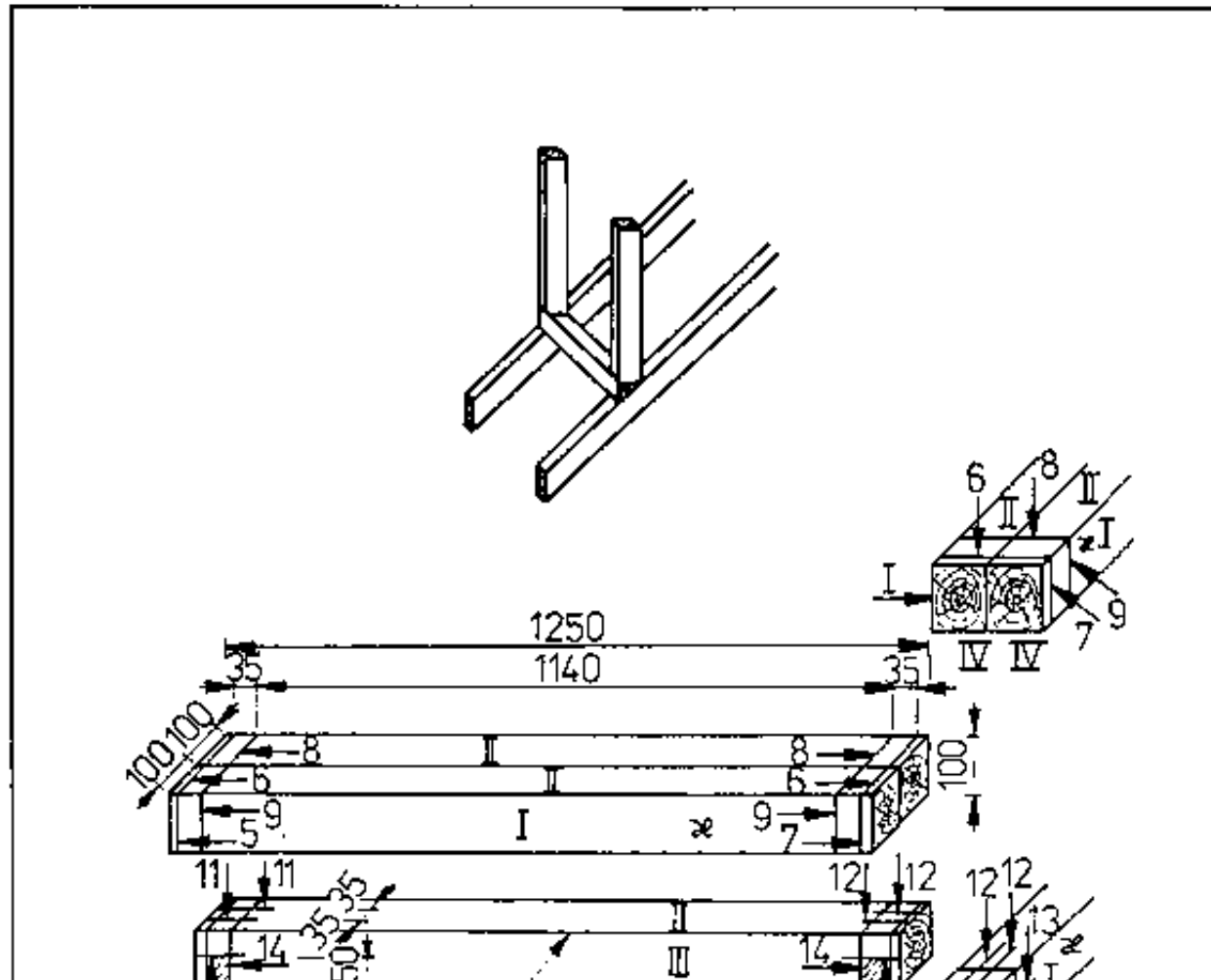

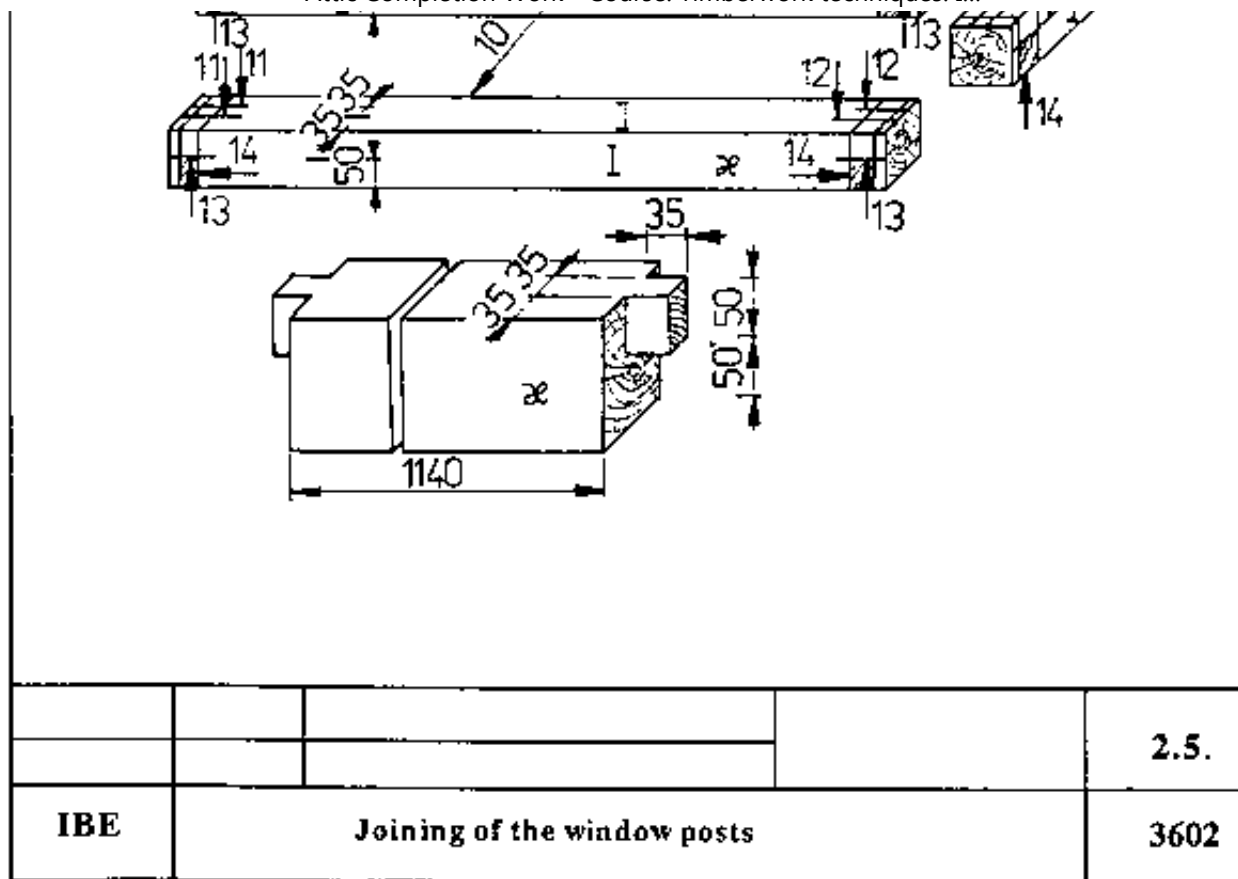

### Joining of the window post









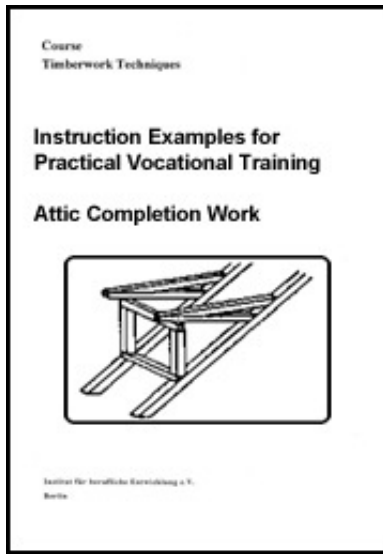

[Home](#) > [ar](#).[cn](#).[de](#).[en](#).[es](#).[fr](#).[id](#).[it](#).[ph](#).[po](#).[ru](#).[sw](#)

 **Attic Completion Work - Course: Timberwork techniques. Instruction examples for practical vocational training (Institut fr Berufliche Entwicklung, 39 p.)**

 **(introduction...)**



-  **Preliminary Remarks**
-  **Instruction Example 2.1.: Making Openings for Roof Superstructures in Existing Roofing**
-  **Instruction Example 2.2.: Making a Rafter Trimming**
-  **Instruction Example 2.3.: Making the Opening for the Roof Window to be Built in**
-  **Instruction Example 2.4.: Joining of the Parapet Transom**
-  **Instruction Example 2.5.: Joining of the Window Posts**
-  **Instruction Example 2.6.: Joining of the Lintel Transom**
-  **Instruction Example 2.7.: Joining of the String Transoms and Roof Rafters**

## **Instruction Example 2.6.: Joining of the Lintel Transom**

**This instruction example teaches how to join the lintel transom for an upright roof window with lean-to dormer roof.**

### **Constructional details**

- **The opening in the roofing has already been made.**
- **Window posts are to be joined with a corner tenon.**
- **Cross sections of timbers are shown in the workshop drawing on page 7.**
- **Lintel transom is cut to a length of 950 mm.**

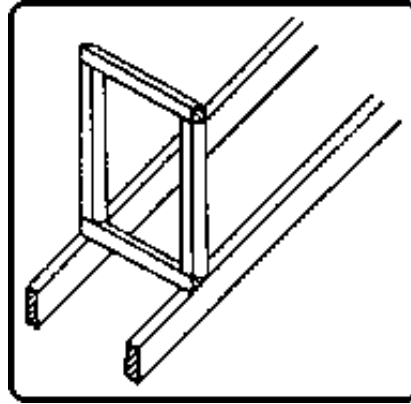

**Figure**

## **Hand tools**

**Hammer**

**Measuring and testing means**

**Folding rule**

**Auxiliary accessories**

**Trestles (one ell), pencil, marking gauge, workshop drawing, engineer's square**

**Necessary previous knowledge**

**Measuring, scribing, angling, use of marking-out marks, reading of drawings**

**Explanations to the working drawing**

**The figures 2 to 7 represent the steps as per sequence of operations.**

## **I joining side, II bottom side of lintel transom. III side opposite to joining side, IV top side of lintel transom**

### **Sequence of operations**

### **Comments**

- |   |   |
|---|---|
| 1. Prepare the working place, erect the trestles with the correct distance.   | Check the trestles for firm standing and stability!<br>Store timbers to be joined, which are not used now, outside the working area.  |
| 2. Put lintel transom on trestles, decide on joining side and mark with marking-out mark.   | Joining side "I" shall have an even face!<br>Any slight camber is to be used as top side of the lintel transom and to be marked with "IV"!  |
| 3. Scribe section line at left end of lintel transom, angle onto all four faces and mark with marking-out mark.                       | Go only as far to the right as to permit a right-angle section to be produced! Use engineer's square for scribing! Place lintel transom so that face marked "II" is on top again! |
| 4. Measure-in length of lintel transom from section line towards the right, angle onto all four faces and mark with marking-out mark. | Place folding rule exactly and in parallel! Use engineer's square for scribing!   |
| 5. Measure-in and scribe window post width, starting from left and right section line and measuring towards the centre.               | For window post widths see Instruction Example 2.4.!  |
| 6. Measure-in and scribe the corner tenon width from the two scribed lines towards the ends of the lintel transom.                    | Scribed line must be in parallel with scribed line of step 5. above!  |
| 7. Scribe corner tenon.   | Use marking gauge and place sharp pencil exactly  |

Use marking gauge and place sharp pencil exactly at marking gauge end face! Do not cant marking gauge when scribing!  
Pass marking gauge along joining side for the two scribed lines!

8. Chisel out the mortise, cut lintel transom to length, take it off the trestles and store it outside the working area.

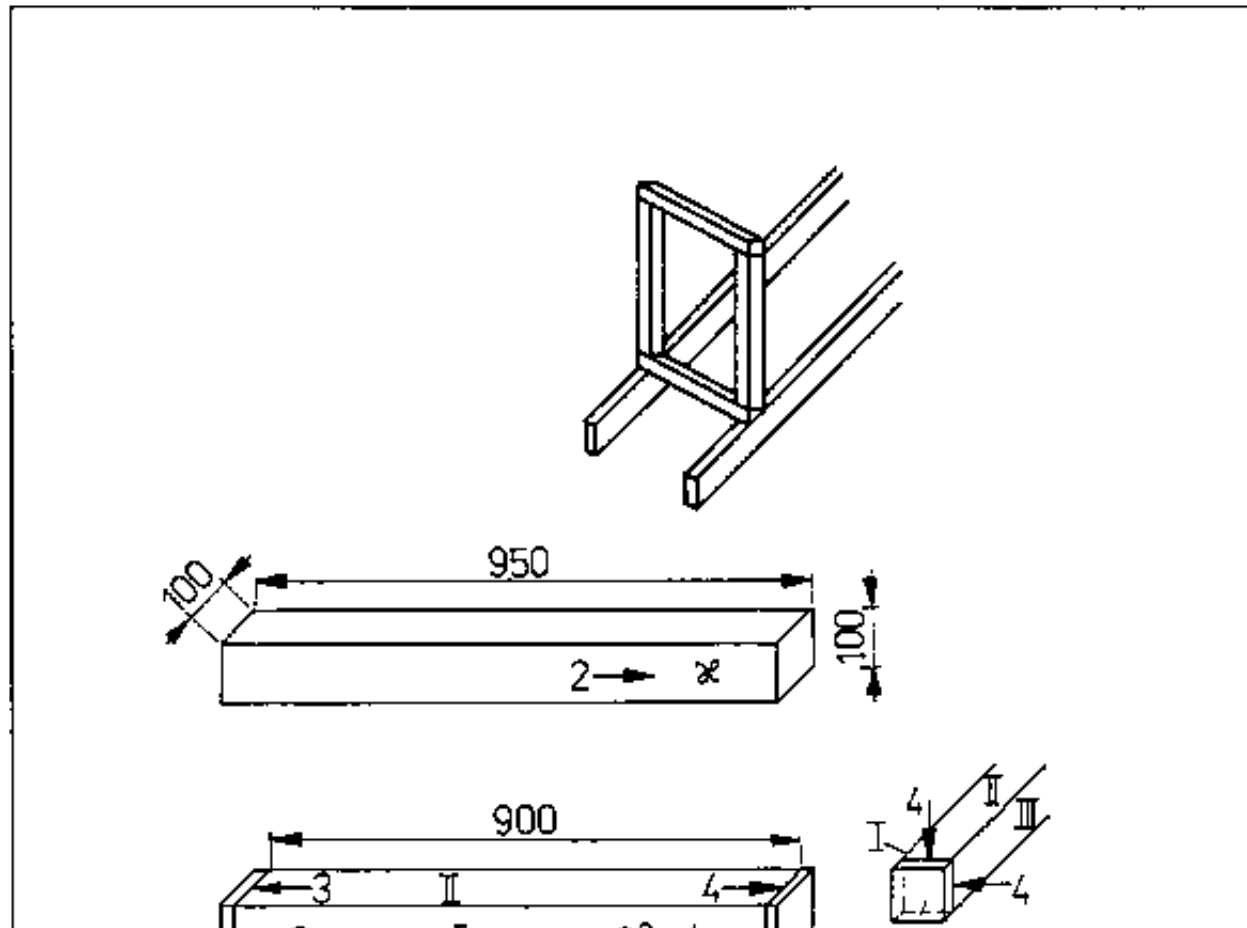



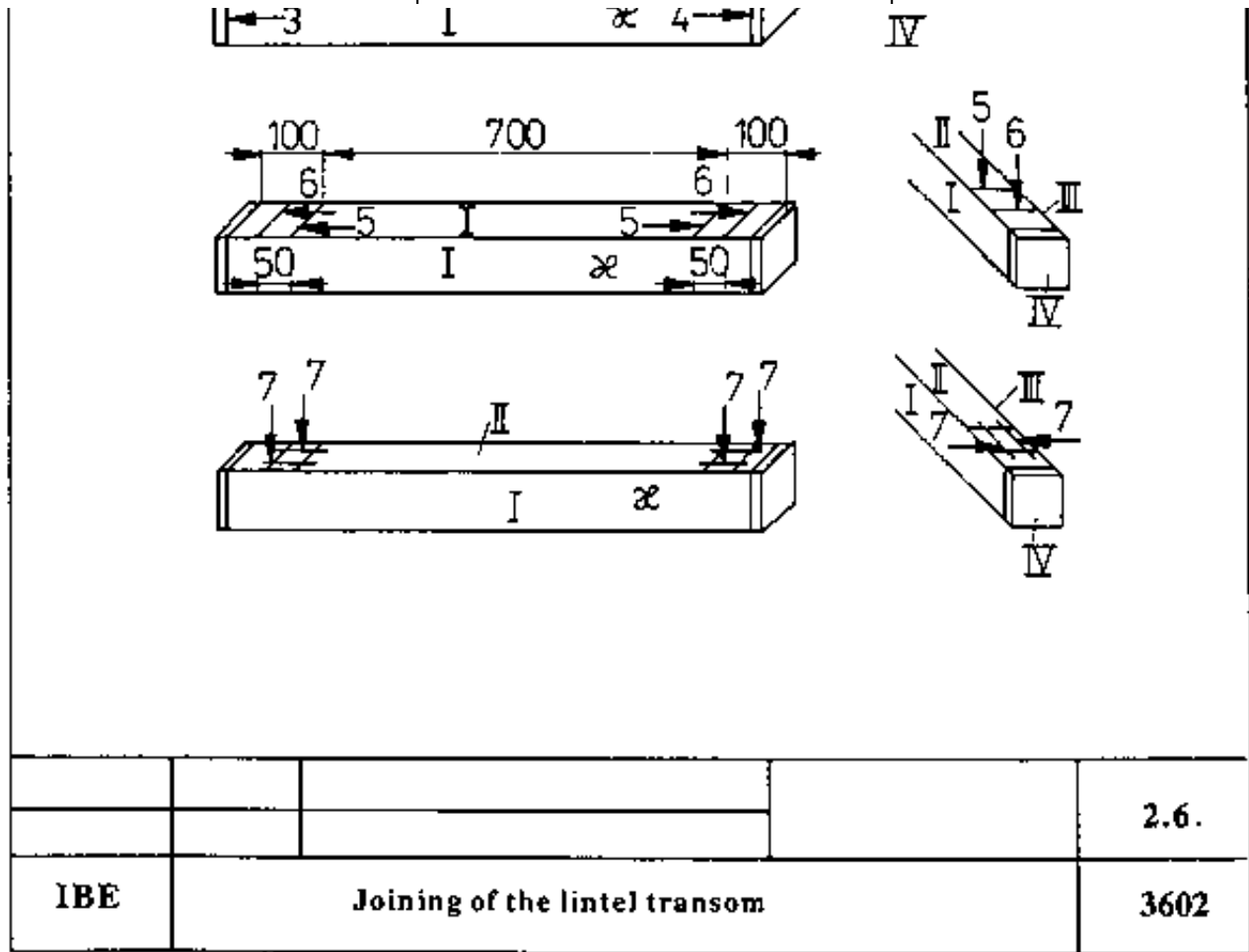

**Joining of the lintel transom**



[Home](#) > [ar](#).[cn](#).[de](#).[en](#).[es](#).[fr](#).[id](#).[it](#).[ph](#).[po](#).[ru](#).[sw](#)

 **Attic Completion Work - Course: Timberwork techniques. Instruction examples for practical vocational training (Institut fr Berufliche Entwicklung, 39 p.)**

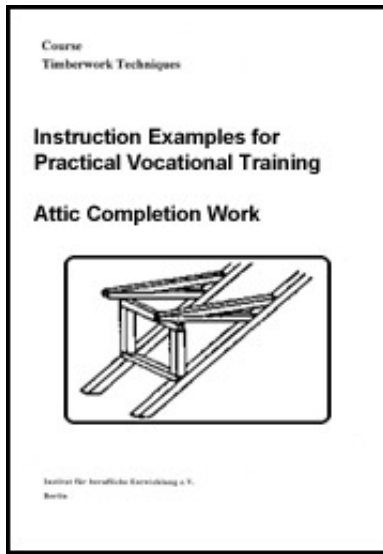

- 📄 **(introduction...)**
- 📄 **Preliminary Remarks**
- 📄 **Instruction Example 2.1.: Making Openings for Roof Superstructures in Existing Roofing**
- 📄 **Instruction Example 2.2.: Making a Rafter Trimming**
- 📄 **Instruction Example 2.3.: Making the Opening for the Roof Window to be Built in**
- 📄 **Instruction Example 2.4.: Joining of the Parapet Transom**
- 📄 **Instruction Example 2.5.: Joining of the Window Posts**
- 📄 **Instruction Example 2.6.: Joining of the Lintel Transom**
- ➔ 📄 **Instruction Example 2.7.: Joining of the String Transoms and Roof Rafters**

## **Instruction Example 2.7.: Joining of the String Transoms and Roof Rafters**

**This instruction example teaches how to join the string transoms and roof rafters for an upright roof window with lean-to dormer roof to be built in.**

### **Constructional details**

- **String transoms are to be supported on main roof rafters and cogged in the lintel transom.**
- **Roof rafters are to be supported on rafters of the main roof and on the string transoms.**
- **Cross sections of timbers are shown in the working drawing of Instruction Example 2.4.**

**- String transoms are cut to a length of 1750 mm and roof rafters are cut to a length of 2750 mm.**

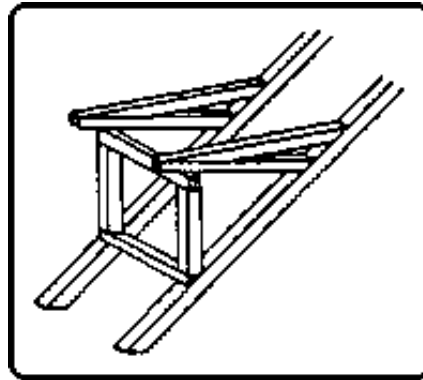

**Figure**

## **Hand tools**

**Hammer**

**Measuring and testing means**

**Folding rule**

**Auxiliary accessories**

**Workshop and detail drawings, trestles (one ell), pencil, hand sketch, engineer's square**

**Necessary previous knowledge**

**Measuring, scribing, angling, use of marking-out marks, reading of drawings,**

## reading of tabular values

### Sequence of operations

1. Study workshop and detail drawings and draw hand sketch for determination of timber lengths.
2. Calculate the timber lengths for string transoms and roof rafters and the recess sizes for scribing.

Calculation method:

Length of string transom (V)

$$V = (250 + 1134 + 120) \text{ mm} = 1710 \text{ mm}$$

V chosen = 1750 mm

Length of roof rafter (VI<sub>0</sub>)

$$\begin{aligned} VI_0 &= X^2 + V^2 \\ &= 840^2 \text{ mm}^2 + (250 + 1340 + 960)^2 \\ &\text{mm}^2 \end{aligned}$$

$$VI_0 = 2684.8 \text{ mm, chosen} = 2750 \text{ mm}$$

Recess sizes (VI<sub>1</sub>, VI<sub>2</sub>)

$$VI_1 : V = X : VII$$

### Comments

See working drawings 3 and 7 and calculation method below!

$$VI_2 = \frac{VIII}{\tan_2} = \frac{120\text{mm}}{0.5045}$$

$$VI_2 = 237.9 \text{ mm}$$

$$V_{I_1} = \frac{V \cdot VIII}{X}$$

$$= \frac{2550 \text{ mm} \cdot 120 \text{ mm}}{840 \text{ mm}}$$

$\alpha_2 = 180 \text{ degrees} - (135 \text{ degrees} + 18.23 \text{ degrees})$

$\alpha_2 = 26.77 \text{ degrees}$

$\tan \alpha = \tan 26.77 \text{ degrees} = 0.5045$

3. Prepare working place, erect trestles with correct distance.

4. Put string transoms on trestles, decide on joining side and mark with marking-out mark.

5. Put string transoms closely together on trestles.

6. Scribe section line at left ends of string transoms and mark with marking-out

Check trestles for firm standing and stability!

Joining side "I" shall have an even face!  
Use any camber of timbers for top face of string transoms and mark with "IV"!

Place string transoms so that face marked with "II" is visible from above!

The left ends of string transoms to be about flush, hammer with gentle hammer blows to make them flush, if necessary!

Go only as far to the right as to permit a right-angle section to be produced!

- mark
7. Angle section line at both joining sides, scribe and mark with marking-out mark. Place engineer's square exactly!
  8. Measure-in maximum length at right ends of string transoms, scribe section line and mark with marking-out mark. For maximum length of string transoms see calculation method!  
Measure from section line 6. towards the right, place folding rule in parallel with timber edge, place exactly at section. Let folding rule tongues engage correctly!
  9. Angle section line at the joining sides at the right ends of string transoms, scribe and mark with marking-out mark. Place engineer's square exactly!
  10. Measure-in recess sizes from the section lines of the left and right ends of string transoms towards the centre, scribe and mark with marking-out marks. Do not mix up the recess sizes!  
The string transoms cannot be interchanged because they are to be cogged in the lintel transom!
  11. Measure-in the inclination of the rafters of the main roof at the left ends of the string transoms, scribe and mark with marking-out mark. Use leg of square for scribing, place it exactly!  
Scribe inclination on both joining sides! For recess sizes see working drawing 4!
  12. Measure-in inclination of cornice at the right ends of the string transoms, scribe and mark with marking-out mark. Use leg of square for scribing, place it exactly!  
Sizes see working drawing 4!
  13. Measuring-in and scribe the front edge of the lintel transom from the right section line of the string transoms towards the left. Scribe thin line and use engineer's square.

14. Measure in to the left and scribe the

For width see working drawing 4!

14. Measure-in to the left and scribe the lintel transom width.

FOR WIDTH SEE WORKING DRAWING 4!

15. Angle scribed lines of 13. and 14. at the joining sides and scribe.

Do not scribe the lines over the total timber width!

16. Measure-in and scribe cog depth.

For cog depth see working drawing 4!

17. Mark wood to be removed for cog recess.

Mark with diagonal lines!

18. Put string transoms apart, scribe on inner faces and mark.

Scribe all lines as on the joining side!

19. Work string transoms, take them off the trestles and store them outside the working area.

Use supports when storing them!

20. Put roof rafters on trestles, decide on joining side and mark with marking-out mark.

Joining side "I" to have an even face!  
In the event of any slight camber, mark such faces with "IV" and put them on the trestles with the faces down!

21. Put roof rafters closely together on trestles.

Shown on page 12 but not identified by figures.

Place timbers so that faces marked "II" are visible from above and left ends of roof rafters are about flush, to be made flush by gentle hammer blows, if necessary.

22. Scribe section line at left ends of roof rafters and mark with marking-out mark.

Go only as far to the right as necessary to produce a right-angle section!

23. Angle section lines at the joining sides. Use engineer's square, place it exactly and

scribe and mark with marking-out mark.  
24. Measure-in, scribe and mark with marking-out mark the roof rafter length.

25. Angle right-end section line of roof rafter length, scribe and mark with marking-out mark.

26. Measure-in the recess size ( $VI_1$ ) at the left ends of the roof rafters, scribe and mark with marking-out mark.

27. Scribe roof pitch (inclination) of main roof on joining sides and mark with marking-out marks.

28. Measure-in the recess size at the right ends of the roof rafters, scribe and mark with marking-out mark.

29. Scribe rafter foot bevels and mark with marking-out mark.

30. Put roof rafters apart and scribe on inner faces (III).

31. Work the roof rafters, take them off the trestles and store them outside the working area.

32. Clear the working place.

scribe thin line!

Place folding rule exactly at section line and scribe exact size  $VI_1$ , otherwise the roof rafter of the lean-to dormer roof will not be supported on the rafter of the main roof!

Use leg of square for scribing and place it exactly at the lines!

Place folding rule exactly, otherwise the foot bevel will not fit on the string transom!

Use leg of square for scribing and scribe exactly!

Scribe all lines as on the joining sides! The roof rafters may be placed with the joining sides on the trestles when scribing!

Use supports for storing them!



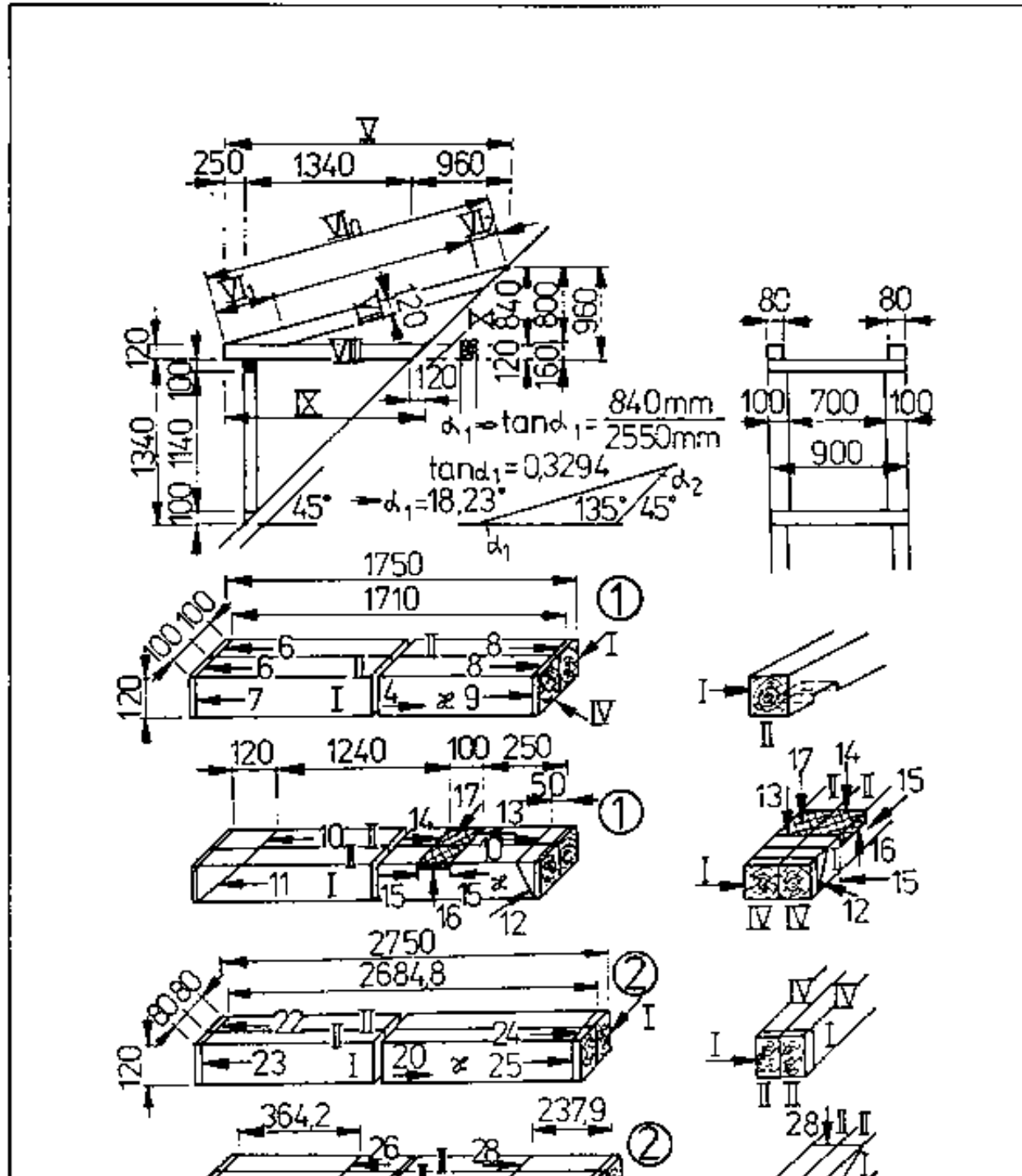

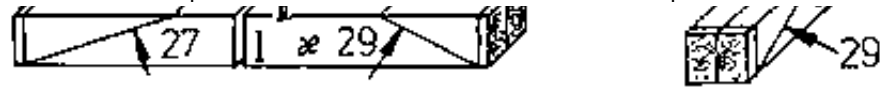

				2.7.
<b>IBE</b>	<b>Joining of the string transoms and roof rafters</b>			<b>3602</b>

### Joining of the string transoms and roof rafters

