

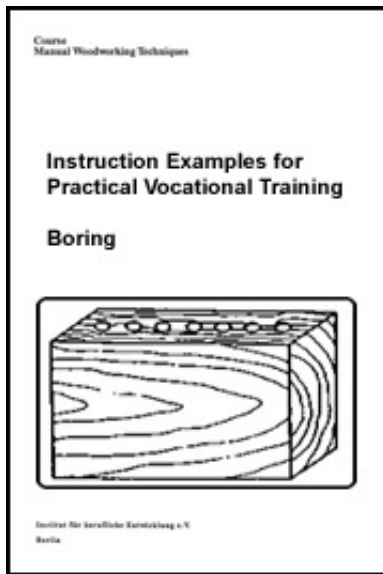













[Home](#) > [ar.cn.de.en.es.fr.id.it.ph.po.ru.sw](#)



- ➔  **Boring - Course: Manual woodworking techniques. Instruction examples for practical vocational training (Institut für Berufliche Entwicklung, 23 p.)**
-  **(introduction...)**
-  **Preliminary Remarks**
-  **Instruction Example 5.1.: Holes of Limited Depth**
-  **Instruction Example 5.2.: Bit Stand**
-  **Instruction Example 5.3.: Screw Holes**
-  **Instruction Example 5.4.: Through Holes**
-  **Instruction Example 5.5.: Stool**



[Home](#) > [ar.cn.de.en.es.fr.id.it.ph.po.ru.sw](#)

-  **Boring - Course: Manual woodworking techniques. Instruction examples for practical vocational training (Institut für Berufliche Entwicklung, 23 p.)**
- ➔  **(introduction...)**
-  **Preliminary Remarks**
-  **Instruction Example 5.1.: Holes of Limited Depth**
-  **Instruction Example 5.2.: Bit Stand**
-  **Instruction Example 5.3.: Screw Holes**



Instruction Example 5.4.: Through Holes

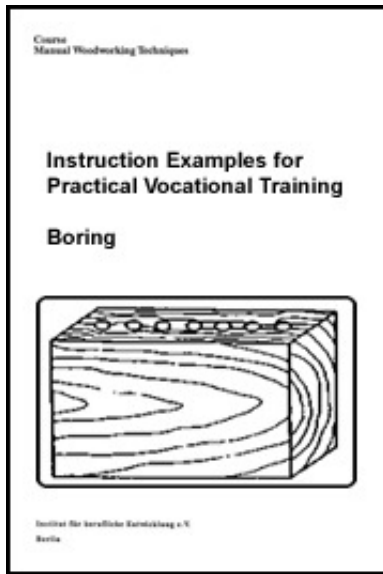

**Institut für berufliche Entwicklung e.V.
Berlin**

**Original title:
Lehrbeispiele für die berufspraktische Ausbildung
"Bohren"**

Author: Fritz Dienemann

First edition © IBE

**Institut für berufliche Entwicklung e.V.
Parkstraße 23
13187 Berlin**

Order No.: 93-33-3305/2



[Home](#) > [ar](#).[cn](#).[de](#).[en](#).[es](#).[fr](#).[id](#).[it](#).[ph](#).[po](#).[ru](#).[sw](#)

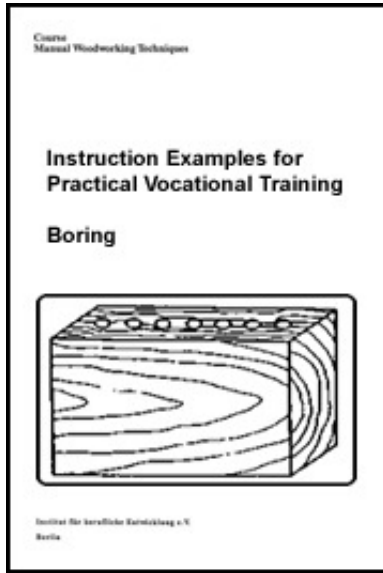

 **Boring - Course: Manual woodworking techniques. Instruction examples for practical vocational training (Institut für Berufliche Entwicklung, 23 p.)**

 **(introduction...)**

  **Preliminary Remarks**

 **Instruction Example 5.1.: Holes of Limited Depth**

 **Instruction Example 5.2.: Bit Stand**

 **Instruction Example 5.3.: Screw Holes**

 **Instruction Example 5.4.: Through Holes**

 **Instruction Example 5.5.: Stool**

Preliminary Remarks

The present booklet contains 5 selected examples of workpieces to be produced by the trainees in order to acquire fundamental knowledge and skills in the working technique of boring. In order to facilitate the preparation and accomplishment of the work, the necessary materials, cutting tools, measuring and testing tools and auxiliary accessories are specified for each instruction example.

Boring calls for knowledge of measuring and scribing. Therefore, such knowledge previously acquired is to be repeated at the beginning.

The sequence of operations specified for each example gives the steps necessary for acquiring the working technique and producing the workpiece. This sequence of operations is to be strictly observed if good quality is to be achieved.

A working drawing showing the required shapes and dimensions of the workpiece is attached to each example.



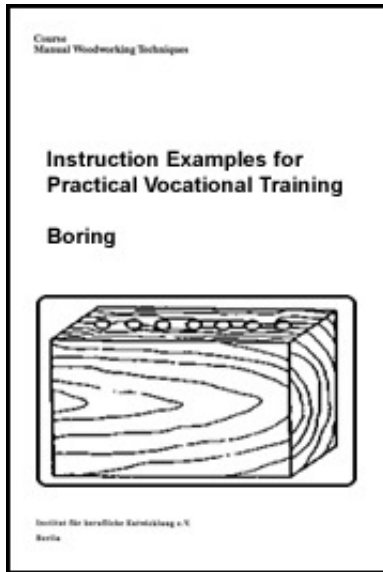

[Home](#) > [ar](#).[cn](#).[de](#).[en](#).[es](#).[fr](#).[id](#).[it](#).[ph](#).[po](#).[ru](#).[sw](#)



 **Boring - Course: Manual woodworking techniques. Instruction examples for practical vocational training (Institut für Berufliche Entwicklung, 23 p.)**

 **(introduction...)**

 **Preliminary Remarks**

  **Instruction Example 5.1.: Holes of Limited Depth**

 **Instruction Example 5.2.: Bit Stand**

 **Instruction Example 5.3.: Screw Holes**

 **Instruction Example 5.4.: Through Holes**

 **Instruction Example 5.5.: Stool**

Instruction Example 5.1.: Holes of Limited Depth

This example serves to practise boring out of faulty spots in solid wood for subsequent setting of end grain dowels.

Material

Planed boards of deciduous (hard) wood and coniferous (soft) wood for various operations.

The boards may have any dimensions but should have defects like loose knots, black knots, resin galls, etc.

Tools

Bit brace and Forstner auger bits of various diameters

Auxiliary accessories

Work bench or carpenter's bench, adhesive, end grain dowels of various diameters

Necessary previous knowledge

Properties of wood, influence of wood defects on the use-value properties of the finished workpieces

Sequence of operations

1. Prepare the working place.
2. Put the defective board or part on the work bench.
3. Check the right and left sides of the wood for defects.
4. Chuck the Forstner auger bit with

Comments

- Check the boring tools.
- Surface to be bored must be in horizontal position.
- Find out the wood defects to be bored out.

the required diameter into the bit
brace.

5. Bore out the defective spot.

Hold the boring tools in vertical position and bore out to the necessary depth only (depending on the defects).

6. Glue in the end grain dowel.

Make sure that the direction of the wood grains is correct.

7. Check the surfaces.

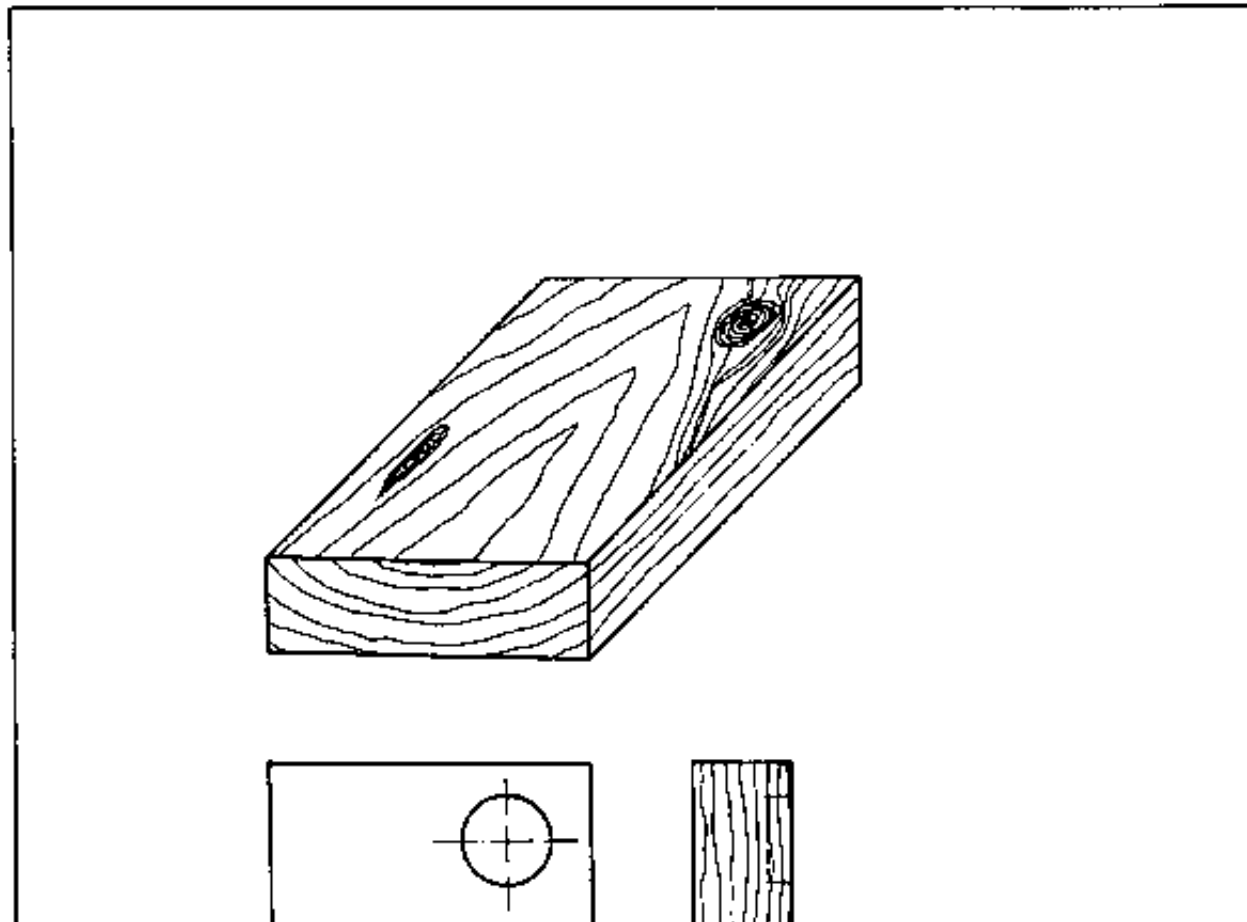

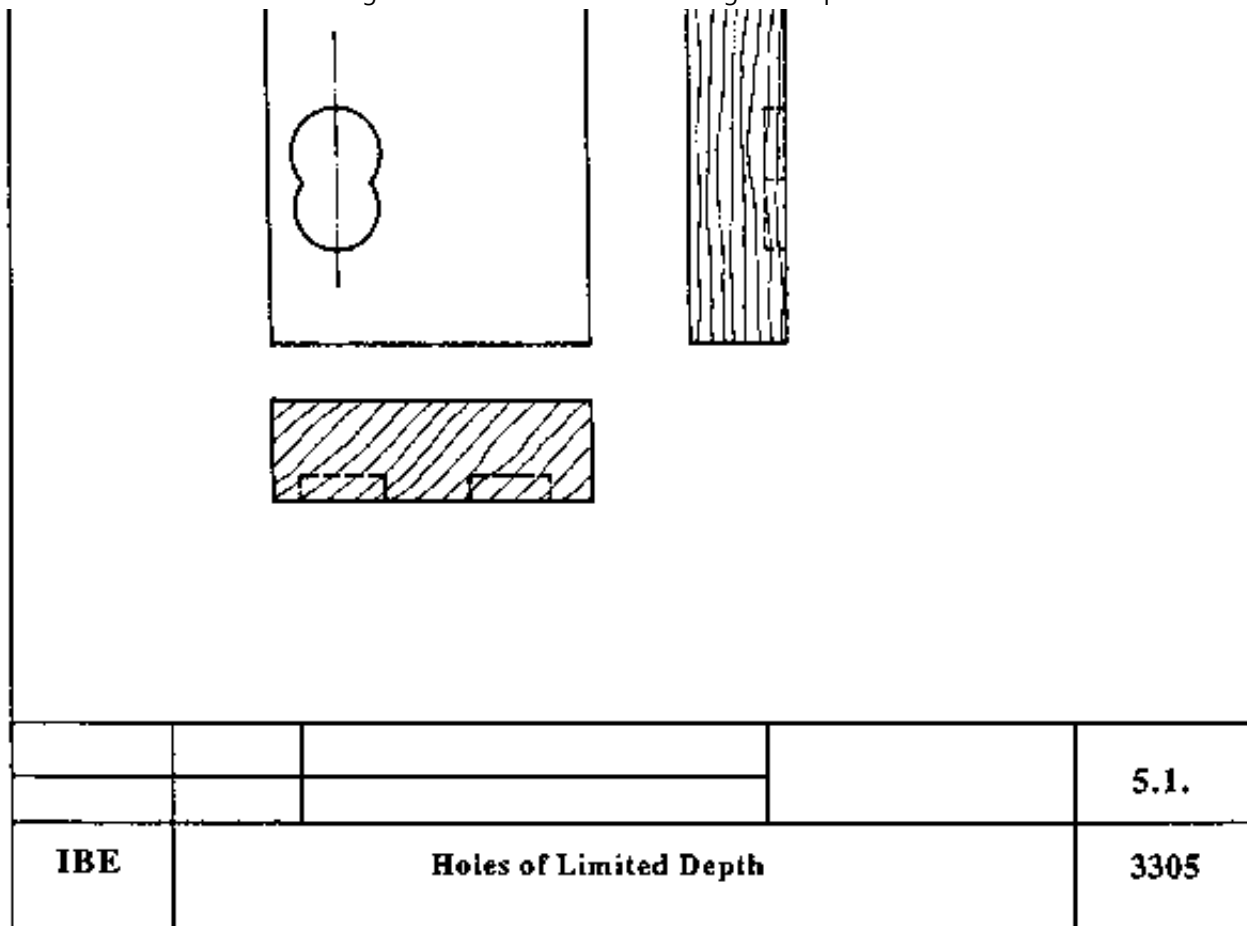

Holes of Limited Depth



[Home](#) > [ar](#).[cn](#).[de](#).[en](#).[es](#).[fr](#).[id](#).[it](#).[ph](#).[po](#).[ru](#).[sw](#)

 **Boring - Course: Manual woodworking techniques.
Instruction examples for practical vocational training
(Institut fr Berufliche Entwicklung, 23 p.)**

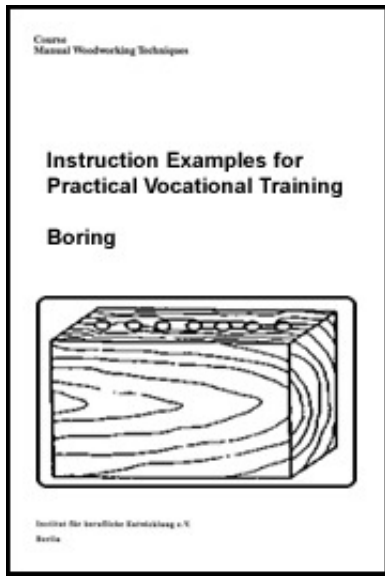

(introduction...) Preliminary Remarks



Instruction Example 5.1.: Holes of Limited Depth



Instruction Example 5.2.: Bit Stand



Instruction Example 5.3.: Screw Holes



Instruction Example 5.4.: Through Holes



Instruction Example 5.5.: Stool

Instruction Example 5.2.: Bit Stand

To practise the manufacture of a device for storing bits at the working place.

Material

A piece of hard or soft wood without branches, if possible.

Dimensions:

Thickness: 40 mm

Width: 150 mm

Length: 400 mm

The piece of wood is planed and sawn to size.

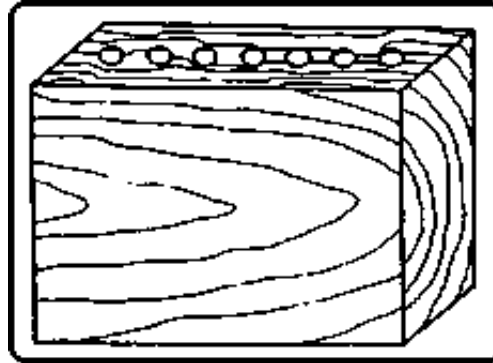

Figure

Tools, measuring and testing means

Bit brace, auger bits of various diameter, marking gauge, folding rule or measuring tape, try square, awl

Auxiliary accessories

Carpenter's bench, scribe or pencil

Necessary previous knowledge

Measuring and scribing, units of measurement, properties of wood

Explanations to the working drawing

Front view and top view of the workpiece, scale 1 : 2.5

Sequence of operations

Comments

Check the boring tools.

1. Prepare the working place.

2. Clamp the workpiece. Make sure that it is in horizontal position.
3. Scribe the centre line by means of the marking gauge.
4. Determine and scribe the hole distances and hole diameters. Hole diameter to be specified by the instructor or bit shank/square tang to be measured at the real bit.
5. Select the bit and chuck it in the bit brace. Use auger bits, if possible.
6. Mount the hole depth setter. Hole depth depends on the bit to be stored.
7. Bore holes of equal diameters. Vertical hole axis is important!
8. Replace the bit. Smaller holes are to be bored for bits of smaller diameter.
9. Mount the hole depth setter.
10. Bore the holes. Repeat replacement of bits and boring until all holes are produced.
11. Check the results.

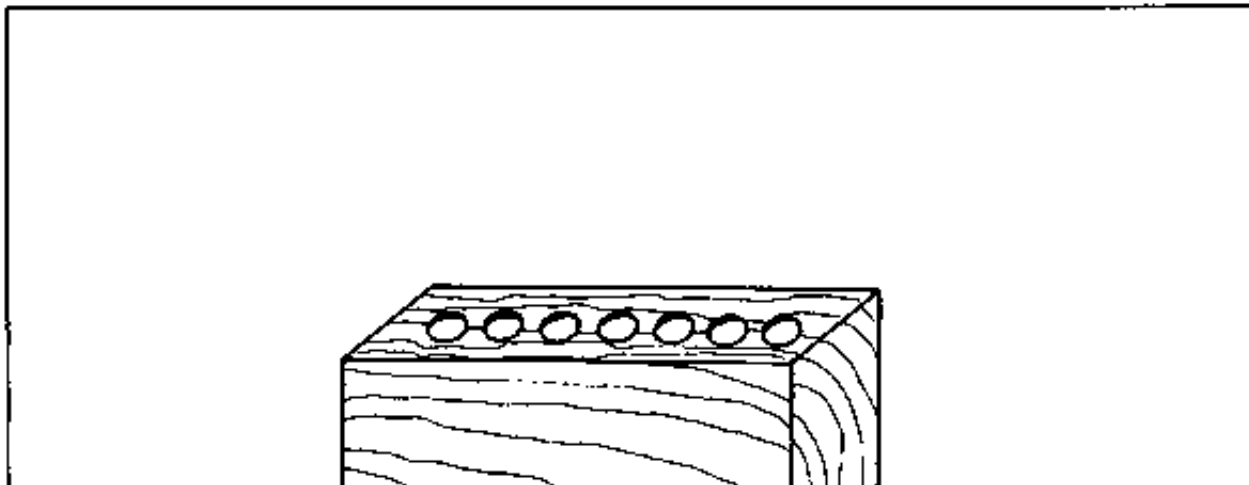

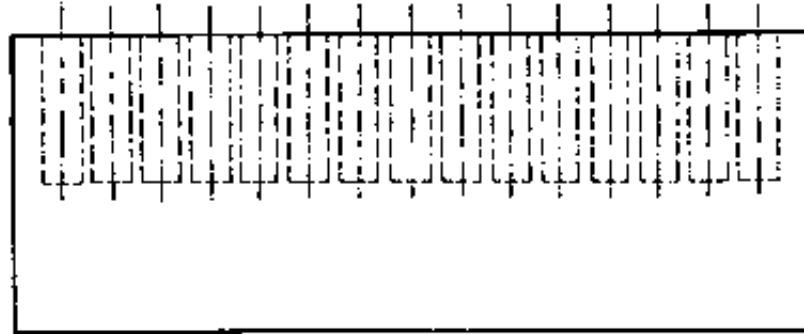

				5.2.
IBE	Bit Stand			3305

Bit Stand



[Home](#) > [ar](#).[cn](#).[de](#).[en](#).[es](#).[fr](#).[id](#).[it](#).[ph](#).[po](#).[ru](#).[sw](#)

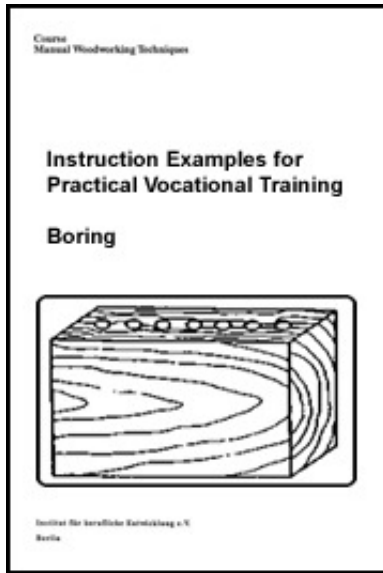

 **Boring - Course: Manual woodworking techniques. Instruction examples for practical vocational training (Institut für Berufliche Entwicklung, 23 p.)**

 **(introduction...)**

 **Preliminary Remarks**

 **Instruction Example 5.1.: Holes of Limited Depth**

 **Instruction Example 5.2.: Bit Stand**

  **Instruction Example 5.3.: Screw Holes**

 **Instruction Example 5.4.: Through Holes**

 **Instruction Example 5.5.: Stool**

Instruction Example 5.3.: Screw Holes

Wood screws of larger diameter and greater length call for pre-bored holes in the wood. This is necessary for many workpieces. Instead of the board door described here, any other workpiece with wood screws maybe used for practising.

Material

Boards, cross and diagonal braces of soft or hard wood

Dimensions:

Designation Pcs. Thickness Width Length

		mm	mm	mm
Boards	6	20	150	1900
Cross braces	2	25	120	860
Diagonal brace	1	25	120	1600

All parts are planed and sawn to size, the diagonal brace is fitted to the cross braces.

Tools, measuring and testing means

Bit brace, twist drills, gimlet with ring handle, wood countersink, marking gauge, folding rule or measuring tape, try square, pencil, hole depth setter

Auxiliary accessories

Workbench or trestles, screw clamps, supporting pieces of wood

Necessary previous knowledge

Measuring and scribing, mode of action of wood screws

Explanations to the marking drawing

Board door with 2 cross braces and 1 diagonal brace, scale 1:10

Sequence of operations

1. Prepare the working place.

Comments

Check the tools.

2. Put the individual parts of the board door on the work bench or on trestles, arrange them and clamp them by screw clamps. Check the arranged boards for squareness by means of the try square.
3. Put the cross and diagonal braces on the board door, arrange them acc. to the given sizes and clamp them by screw clamps. Diagonal brace must be tightly fitting between the cross braces.
4. Scribe the screw line with the marking gauge and determine the hole points. Distances and arrangement of the screw holes are given in the drawing.
5. Select the drill and chuck is in the bit brace. Drill diameter to be 2 mm less than the diameter of the wood screws used. If a gimlet with ring handle is used, chucking in the bit brace is not necessary.
6. Mount the hole depth setter. Hole depth to be 5 mm less than the screw length.
7. Drill the holes. Vertical boring axis is important!
8. Release the drill and chuck the countersink (rose bit). If screws with countersunk heads are used, countersink the holes according to the size of the screw head.
9. Countersink the holes.
10. Check the results. Check if the wood screws can be easily screwed into the wood.

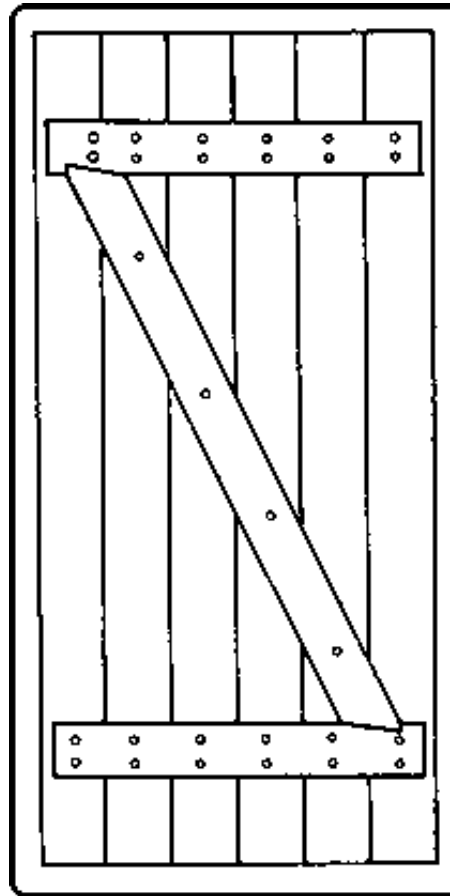

Screw Holes



[Home](#) > [ar](#).[cn](#).[de](#).[en](#).[es](#).[fr](#).[id](#).[it](#).[ph](#).[po](#).[ru](#).[sw](#)

 **Boring - Course: Manual woodworking techniques.
Instruction examples for practical vocational training
(Institut fr Berufliche Entwicklung, 23 p.)**

 **(*introduction...*)**

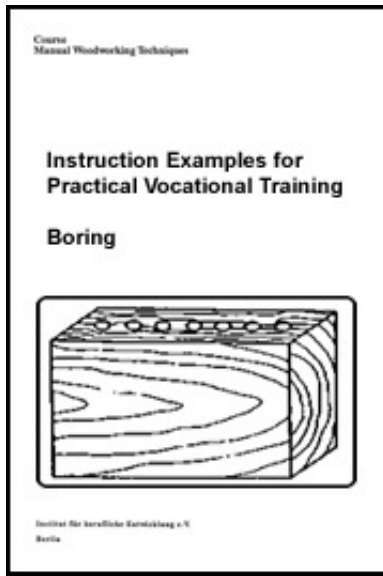

-  **Preliminary Remarks**
-  **Instruction Example 5.1.: Holes of Limited Depth**
-  **Instruction Example 5.2.: Bit Stand**
-  **Instruction Example 5.3.: Screw Holes**
-   **Instruction Example 5.4.: Through Holes**
-  **Instruction Example 5.5.: Stool**

Instruction Example 5.4.: Through Holes

Through holes in wooden materials are required wherever fittings are to be mounted. In this example, the board door from instruction example 5.3. shall be provided with a screw-on lock as lock fitting.

Material

Board door from instruction example no. 3.

The door may already be screwed together.

But it is also possible to just use the outer board, where the lock shall be fitted, as single part.

Tools, measuring and testing means

Bit brace, auger bit or Forstner auger bit with twist drill, marking gauge, try square, folding rule or measuring tape, pencil

Auxiliary accessories

Work bench or trestles, screw clamps, supporting pieces of wood

Necessary previous knowledge

Measuring and scribing

Explanations to the working drawing

1 screw-on lock (lock fitting), 2 lock width, 3 lock height, 4 plug size

Sequence of operations

Comments

1. Prepare the working place.

Check the tools for completeness.

2. Put the board door on the work bench or on trestles.

3. Take the dimensions of the screw-on lock.

Dimensions are shown in the drawing.

4. Scribe the plug

Height of door handle according to local conditions.

size, nut square and centre distance by means of the try square and marking gauge.

5. Select the proper auger bit or Forstner auger bit and chuck it in the bit brace.

6. Bore the holes for the key and for the nut square.

7. Bore a second hole for the key hole, if necessary, to achieve the necessary hole heights.

8. Check the results.

Bit diameter depends on the dimensions on the screw-on lock.

Bore the scribed boring points with the auger bit until the brad point penetrates at the other side of the door, then turn the door over and start boring again at the brad point hole. If a Forstner auger bit is used, drill a guide hole with a thin twist drill first and then bore with the Forstner bit from both sides.

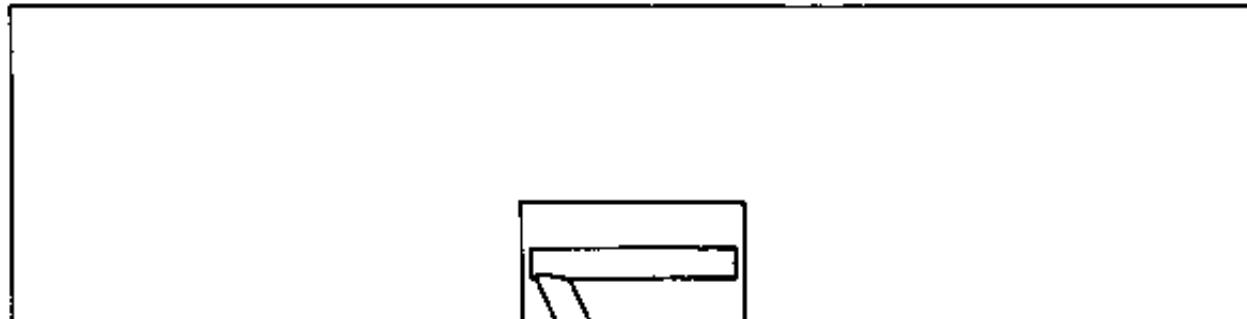

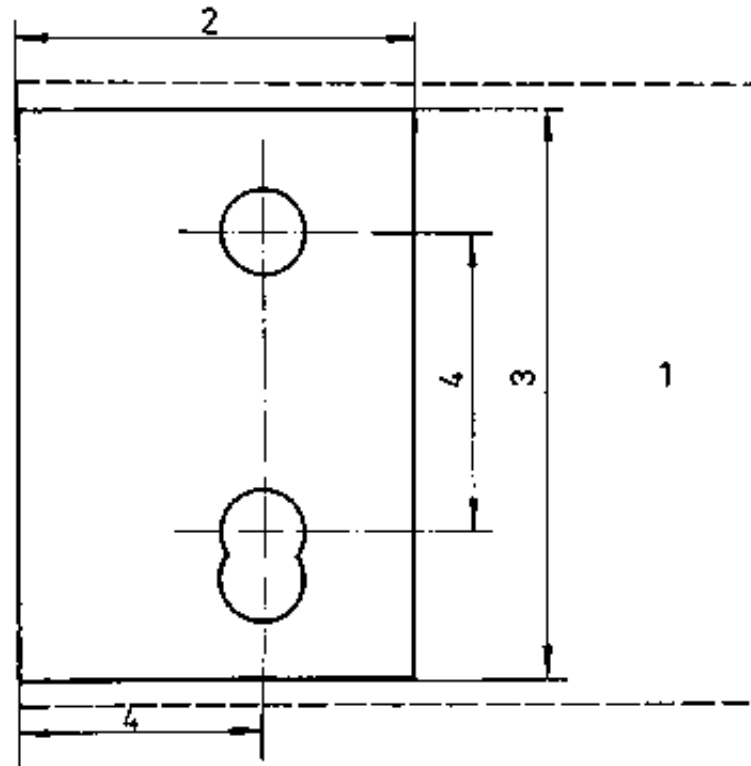
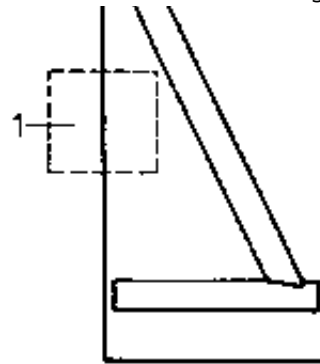

				5.4.

Through Holes



[Home](#) > [ar](#).[cn](#).[de](#).[en](#).[es](#).[fr](#).[id](#).[it](#).[ph](#).[po](#).[ru](#).[sw](#)

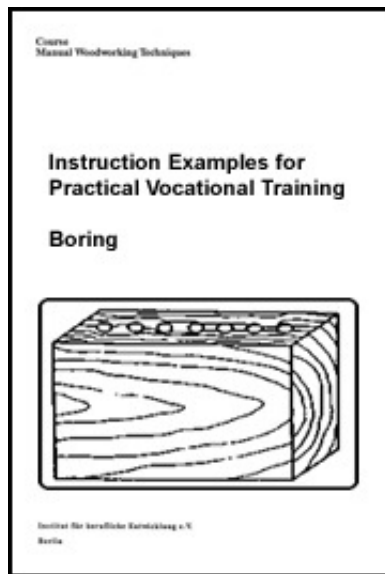

 **Boring - Course: Manual woodworking techniques. Instruction examples for practical vocational training (Institut für Berufliche Entwicklung, 23 p.)**

 **(introduction...)**

 **Preliminary Remarks**

 **Instruction Example 5.1.: Holes of Limited Depth**

 **Instruction Example 5.2.: Bit Stand**

 **Instruction Example 5.3.: Screw Holes**

 **Instruction Example 5.4.: Through Holes**

 **➔ Instruction Example 5.5.: Stool**

Instruction Example 5.5.: Stool

Conical holes are used for wood connection the tenons of which are prevented from slipping off by keying. This example is an exercise for the trainees to practise the manufacture of a simple stool with three legs keyed with their tenons in conical holes.

Material

One wooden disk (seat) and three round bars of hard wood.

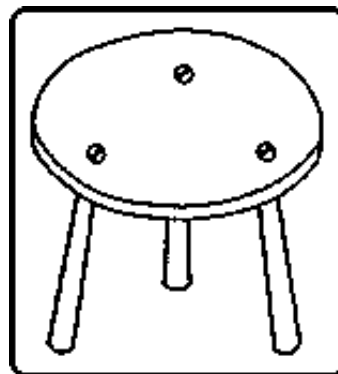

Figure

Dimensions:

Designation Pcs. Thickness Width Length

		mm	mm	mm
Seat (disk)	1	30	350	350
Legs	3	40	40	450

All parts maybe in rough or finished condition.

Tools, measuring and testing means

Bit brace, spoon bit, dividers, straight edge, folding rule or measuring tape, bevel rule, pencil

Auxiliary accessories

Carpenter's bench or work bench

Necessary previous knowledge

Measuring and scribing, fundamentals of geometrical designs

Explanations to the working drawing

**1 seat (disk) - scale 1:2.5, 2 leg - scale 1:1
= diameter**

Sequence of operations

1. Prepare the working place.
2. Clamp the seat.
3. Scribe the holes:
 - determine the centre,
 - draw the circular arc,
 - divide the circular arc into three thirds,
 - scribe the centres of the holes.
4. Select the auger bit and chuck it in the bit brace.
5. Bore the holes.

Comments

Check the cutting edges of the spoon bit.

Dimensions are given in the drawing.

Select a bit diameter to suit the lower hole diameter, if available, otherwise use a smaller diameter.

Boring axis must correspond to the leg position. When practising for the first time, vertical position

should be preferred.

6. Select the spoon bit and chuck it.
Bit with handle need not be chucked.
7. Conically enlarge the existing
holes.
8. Measure the enlarged holes.
9. Continue boring until the specified
diameter is reached.
10. Check the results.

Enlarge the holes up to the upper hole diameter.

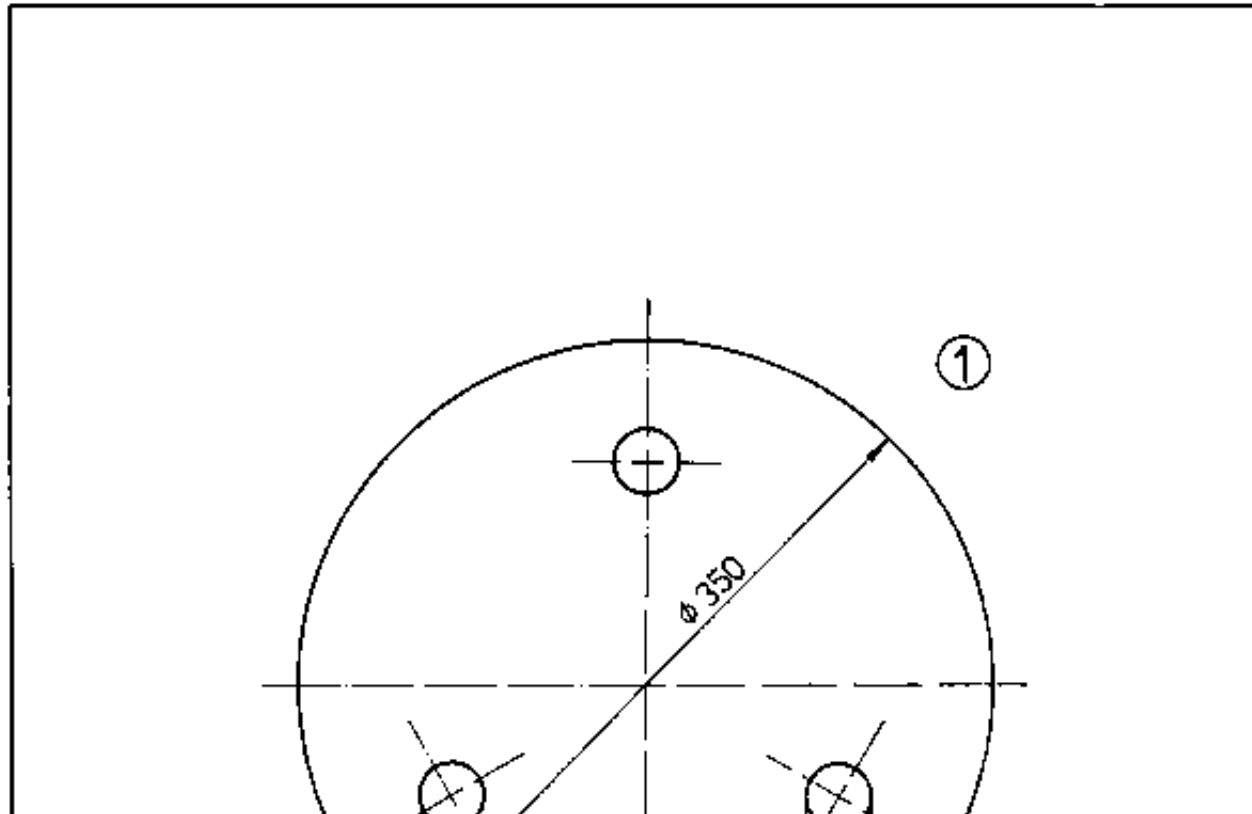

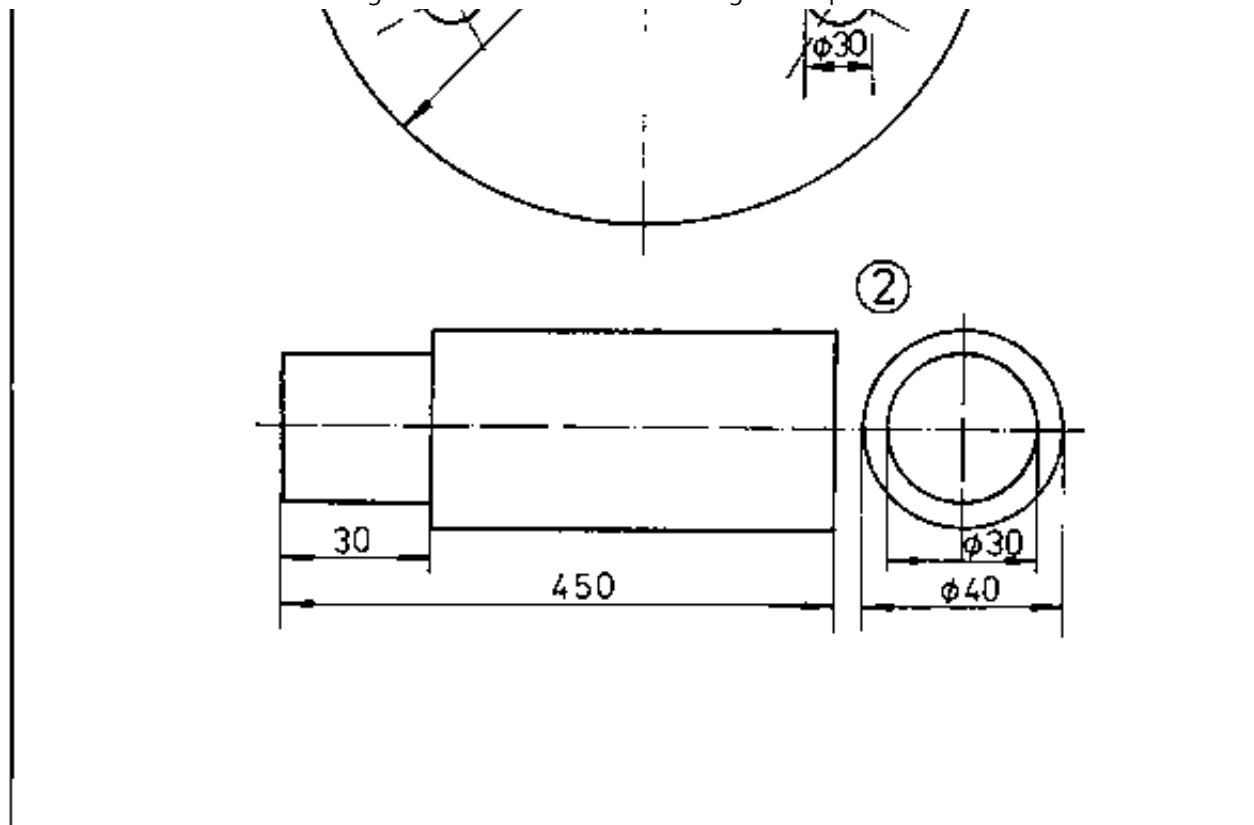

				5.5.
IBE	Stool			3305

Stool

