







Formulae and Tables - Wood / textbooks for vocational training (GTZ, 122 p.)

- ➔ **2. Materials Made of Wood**
 - 2.1. Solid Wood**
 -  *(introduction...)*
 -  **2.1.1. Not Improved Solid Wood**
 -  **2.1.2. Improved Solid Wood**
 -  **2.2. Laminated Wood**
 -  **2.3. Sandwich Boards**
 -  **2.4. Fibreboards**
 -  **2.5. Particle Boards**

Formulae and Tables - Wood / textbooks for vocational training (GTZ, 122 p.)



2. Materials Made of Wood

2.1. Solid Wood



Solid wood is obtained from raw wood by longitudinal and cross cutting. It is used without or after improvement of the wood.

2.1.1. Not Improved Solid Wood

Name	Definition	Remarks
------	------------	---------

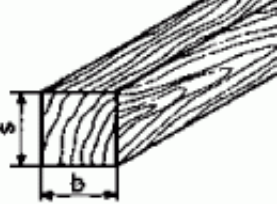
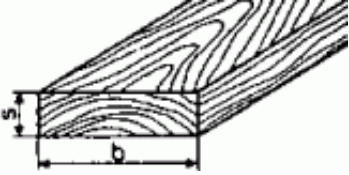
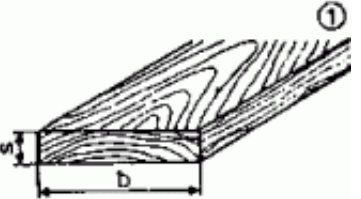
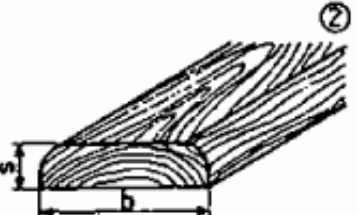
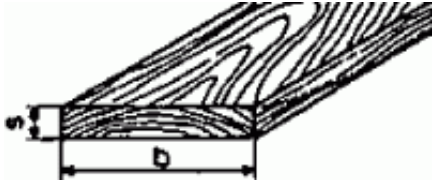

round timber	Round timber is obtained from rough wood by cross cutting. It includes saw logs, veneer flitches, masts, poles and others.	Saw logs and veneer flitches are intermediate products which are intended for further cutting.
Sawn timber	Sawn timber is produced by longitudinal cutting of round timber. Sawn timber has at least 2 parallel surfaces and is thicker than 5 mm.	Making of simple cut and double cut; simple cut: 
		single passage through the machine yields untrimmed products; double cut:
		
		two passages through the machine; first passage is precut, edge boards and slabs are cut off; second passage is second cut; from the material turned by 90° the trimmed product is obtained.
Veneer	Is produced by longitudinal cutting (slicing, sawing) or arcuate cutting-off (peeling) of round wood; veneer is ≤ 3 mm thick and ≥ 80 mm broad.	

Kinds of sawn timber

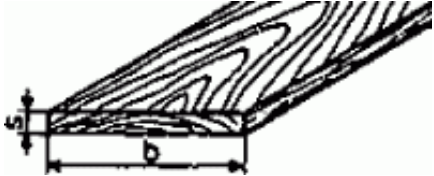
Kinds Schematic representation	Width in mm (b)	Thickness in mm (s)
 <p>squared timber</p>	>100	>100
 <p>frame timber</p>	$\leq 2s$	38...100
  <p>board (1) round-edged (2) edge-trimmed</p>	round-edged $\geq 2s$ edge-trimmed ≥ 75	>16 16...100
 <p>lath</p>	>75	16...35
	edge-trimmed ≥ 75	6...15

 <p>ply</p>		
 <p>strip</p>	<p>or</p> <p>round-edged < 75</p>	<p>6...15</p>

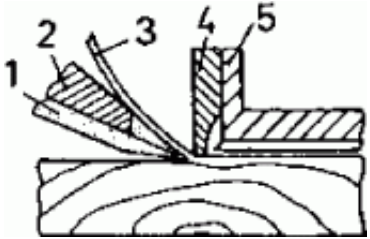
Kinds of veneers

Kinds Schematic representation	Manufacture	
 <p>sliced veneer</p>	<p>Sliced veneers are made by slicing off lamella by lamella in an operation similar to planing. Effective strokes of the machine: 16...36 min⁻¹</p> <p>cutting speed: 0.5 to 1.5 m s⁻¹</p> <p>length: up to 5 m</p> <p>thickness: 0.05 to 2.7 mm</p>	
<p><i>1 knife, 2 knife holder, 3 veneer, 4 pressure strip, 5 pressure bar</i></p>		
	<p>Peeled veneers are taken from a rotating trunk by an operation similar to turning.</p> <p>cutting speed: 0.2 to 2.5 m · s⁻¹</p> <p>length: up to 4.5 m</p> <p>thickness: 0.08 - 2.7 mm</p>	

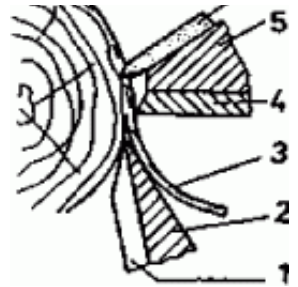

peeled veneer

1 veneer knife, 2 knife holder, 3 veneer, 4 pressure strip, 5 pressure bar, 6 scratcher knife

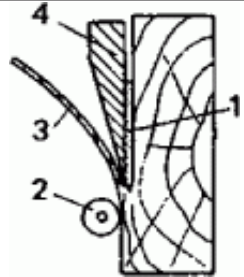

saw veneer

Sawn veneers are produced with a horizontal frame saw or a veneer circular saw. Speed of the veneer frame saw: $200...300 \text{ min}^{-1}$
cutting speed: $6...8 \text{ m} \cdot \text{s}^{-1}$
length: up to 5 m
thickness: 0.5 to 3.0 mm

1 saw blade, 2 compression roll, 3 veneer, 4 cleaving knife

2.1.2. Improved Solid Wood

Kind of solid wood	Manufacture	Application
compressed solid wood	solid wood compressed by pressing, beating or rolling under the influence of pressure and temperature	machine parts in the textile industry, bearing shells, press-drawing tools, etc.
impregnated solid wood	solid wood impregnated with various agents (e.g. resin, oil, metal) for changing its properties	synthetic resin-impregnated timbers in electric engineering, oil-impregnated wood as self-

		lubricating machine parts, metal-impregnated wood as slide bearing
formed solid wood	solid wood formed under the influence of temperature, moisture and pressure (by applying pressure on the cross-grain ends of the blank the latter is compressed and thus made bendable)	for bent parts in furniture construction, in vehicle construction and boat building, for the manufacture of sports equipment etc.

2.2. Laminated Wood

Laminated wood consists of veneer layers which are symmetrically laid one on top of the other. It is glued together by means of adhesive under pressure and temperature to form sheet material. Laminated wood has improved properties compared with solid wood and can be used for many more purposes.

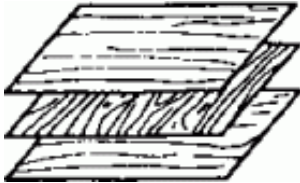
Name	Material construction	Physical quantities	Application
plies (plywood)	 <p>symmetrical arrangement of the veneer layers, the layers are staggered alternately 90° according to the grain direction</p>	$\rho =$ 0.60...075 g · cm ⁻³ δzB =35...55 MPa $\delta dB =$ 60...80 MPa $\delta bB =$	furniture industry, interior work, packaging industry, building industry etc.

		55...75 MPa	
laminated wood	veneers are arranged in parallel with each other (grain direction); up to 15 % vertically to it	$\rho = 0.65...0.95 \text{ g} \cdot \text{cm}^{-3}$ $\delta zB = 80...170 \text{ MPa}$ $\delta dB = 70...110 \text{ MPa}$ $\delta bB = 120..200 \text{ MPa}$	aircraft manufacture, shipbuilding, vehicle construction, timber engineering etc.
compressed laminated wood	arrangement of the veneers is the same as with plywood or laminated wood; by applying pressures of about 10 MPa compression is achieved (10 %)	$\rho = 0.80...1.15 \text{ g} \cdot \text{cm}^{-3}$ $\delta zB \leq 220 \text{ MPa}$ $\delta dB \leq 250 \text{ MPa}$ $\delta bB \leq 250 \text{ MPa}$	machine parts, timber engineering, apparatus construction, toolroom work, vehicle construction
plastic compressed laminated	same as compressed laminated wood, but made of synthetic resin-impregnated veneer	$\rho = 1.15...1.35 \text{ g} \cdot \text{cm}^{-3}$	vehicle construction, electric engineering, apparatus

wood		$\delta zB \leq 140$ MPa $\delta dB \leq 300$ MPa $\delta bB \leq 240$ MPa	construction, timber engineering, machine parts
------	--	---	---

2.3. Sandwich Boards

Sandwich boards consist of a core and two cover plies, one on each side. Compared to the solid starting material considerable savings in material are possible and improved properties are reached.

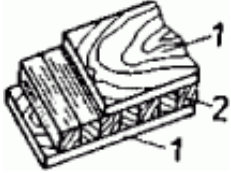
Name	Material construction	Physical quantities	Application
sandwich board with solid wood core		$\rho =$ 0.42...0.52 $g \cdot cm^{-3}$ $\delta dB =$ 12...38 MPa $\delta bB =$ 30...40 MPa	furniture industry, interior work, pattern making, development working etc.
<i>1 cover ply of crossband veneer; thickness ≥ 1.8 mm</i> <i>2 solid wood core of blackboard</i>			

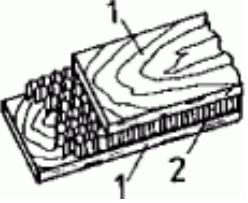
sandwich board with hollow core		$\rho = 0.01 \dots 0.04 \text{ g} \cdot \text{cm}^{-3}$ $\delta zB = 1.7 \text{ MPa}$ $\delta dB = 2.9 \text{ MPa}$ $\delta bB = 14 \text{ MPa}$	doors, partition walls, vehicle construction and shipbuilding, interior work, boat building
<i>1 outer layers of veneer, plywood, hard fibre boards, metal or plastic boards; 2 core of paper honeycombs</i>			
sandwich board with particle board core	Particle boards as cores are coated on both sides with veneer or synthetic resin-impregnated papers. In this way their properties and appearance are improved.	$\rho = 0.7 \dots 0.8 \text{ g} \cdot \text{cm}^{-3}$ face strength $\approx 0.9 \text{ MPa}$ $\delta bB \approx 40 \text{ MPa}$	furniture construction, interior work, ship building and waggon construction

2.4. Fibreboards

Fibreboards are a flat, sheet wood-based material made under the influence of pressure and temperature which consists of fibrous material containing lignocellulose.

Properties of fibreboards

Kind of board	Thickness in mm	Gross density ρ in $\text{g} \cdot \text{cm}^{-3}$	Bending strength δ_{bB} in MPa	Compressive strength δ_{dB} in MPa	Transverse tensile strength δ in MPa
hardened fibreboards	1...6	1.0...1.1	60	50...60	30...55
hard fibreboards	1...6	0.95...1.05	25...75	25...50	15...40
medium hard fibreboards	6...25	30...75	10...40	80	8...25
porous fibreboards	6...20	25...40	1.0...3.0	0.8...2.0	1.0...3.0
medium-dense fibreboards	10...19	0.60...0.85	15...32		0.3...0.7

Use of the fibreboards

Kind of board	Special features	Applications
medium-dense fibreboards	three-layer structure, high surface quality, homogeneous core structure, closed homogeneous narrow surfaces	same as (three-layer) particle boards for furniture, especially for visible outer surfaces of furniture

porous fibreboards	low density, low strength, heat-insulating	ceilings and panellings, roof sheathing, floor underlay
medium-hard fibreboards	heat-insulating	partition walls, panellings, roof sheathing
hard fibreboards	uniform surface, elastic, bendable, nailing and screwing possible	ceiling boarding and panelling, furniture parts, doors, partition walls, coverings
hardened fibreboards	oil-impregnated, especially abrasion-proof, water-repellent	panelling and sheathing outdoors, inner and outer doors, concrete moulds, floor, staircase and table coverings
sound-absorbing boards	porous fibreboards provided with holes, slits or similar for sound absorption	ceiling boarding and panellings in offices, telephone exchanges, cinemas, concert halls etc.
multilayer insulating boards	boards consisting of two or more layers of porous fibreboards glued in a water-proof manner	partition walls, displaceable walls, false ceilings
varnished boards	hard fibreboards with varnish coating	panellings in kitchens, shops, bathrooms, for furniture in rooms in which water is handled
sheet and plastic-coated fibreboards	hard fibreboards coated with coloured plastic sheets or synthetic resin-impregnated special papers	panellings in kitchens and bathrooms, for furniture in damp rooms, for table coverings in kitchens, shops, workshops, laboratories etc.
embossed	hard fibreboards which during	for decorative purposes in interior work

fibrebords	manufacture were given an embossed surface and (possibly subsequently) a colour treatment	
floor boards	extra hard fibrebords which are laid like parquet, high wear resistance	for floor coverings
hard multi-layer boards	boards consisting of two or more layers of subsequently glued medium-hard or hard fibrebords	panels, shock-resistant coverings, partition walls, false ceilings

2.5. Particle Boards

The particle board is a wood-based material made of wood chips with the addition of synthetic resin under the influence of pressure and temperature. Its properties can be varied by the kind and quantity of the additives, by the quality and arrangement of the chips and the compression ratio.

Properties of the particle boards

Kind of board	Thickness in mm	Gross density ρ in $\text{g} \cdot \text{cm}^{-3}$	Bending strength δbB in MPa	Transverse tensile strength ρ in MPa
single-layer flat pressed particle boards	6...25	0.5...0.85	15...20	0.2...0.3
triple-layer	6...25	0.55...0.85	20...30	0.2...0.3

flat pressed particle boards extruded particle boards	8...75	0.55...0.70	≈ 2.0 in pressing direction ≈ 15.0 at right angles to the pressing direction	≈ 0.6 in pressing direction ≈ 4.0 at right angles to the pressing direction
--	--------	-------------	--	--

Use of the particle boards

Kind of board	Special features	Applications
flat pressed particle boards, raw, single-layer	dense surface, heat and sound-insulating, pressure-proof	interior work, building construction, agricultural building, floor underlays, insulating boards etc.
Flat pressed particle boards, raw multi-layer	like single-layer boards, but surface layer consisting of fine particles; dense surface, little swelling	manufacture of furniture, self-supporting structural elements, interior work, vehicle construction
extrusion particle boards, raw	low bending strength, coating absolutely necessary, in other aspects like single-layer boards	core for sandwich boards in furniture manufacture, in interior work, shipbuilding and vehicle construction, building industry
impregnated particle boards	additives are added to the binder, therefore resistant to temperature and wood pests	building industry, agricultural building, shipbuilding
veneer-coated particle	more resistant to varvina	visible surface in furniture

boards	climatic influences, better stability, higher bending strength	manufacture, interior work and shipbuilding, for panelling, cladding
particle boards coated with laminated boards, PVC-hardboards or decorative laminates *)	coating on one side or both sides, higher strength, higher resistance to moisture and chemicals, scratch resistant	furniture in damp rooms, doors, partition walls, structural elements for walls, but also containers, concrete moulds, mainly in the kitchen furniture industry

***) decorative laminates: plastic sheets with wood pattern**



[Home](#) > [ar](#).[cn](#).[de](#).[en](#).[es](#).[fr](#).[id](#).[it](#).[ph](#).[po](#).[ru](#).[sw](#)

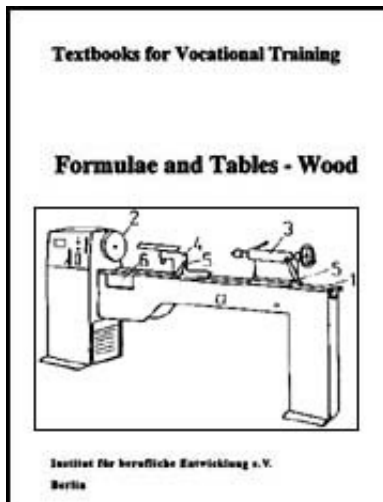

 **Formulae and Tables - Wood / textbooks for vocational training (GTZ, 122 p.)**

  **3. Plastic materials**

 **(introduction...)**

 **3.1. Classification of Plastic Materials**

 **3.2. Properties of Important Plastic Materials**

 **3.3. Applications of Important Plastic Materials**

Formulae and Tables - Wood / textbooks for vocational training (GTZ, 122 p.)

3. Plastic materials

Plastics are synthetic materials or macromolecular organic-chemical materials produced by conversion of polymer natural products.

3.1. Classification of Plastic Materials

Type of plastics	Starting material	Chemical stability
Modified natural materials		
cellulose nitrate	cellulose, nitric acid	resistant to weak acids and alkalis
Polycondensates (thermosetting plastics)		
phenolic moulding compound	phenol or cresol, formaldehyde and filler materials	instable to concentrated acids and alkalis
phenolic laminates	phenol or cresol, formaldehyde and laminar substrates	same as phenolic moulding compounds
urea resins	urea or melamine resins and formaldehyde	same as phenolic moulding compounds
urea resin moulding compounds	urea or melamine resins, formaldehyde and filler materials	same as phenolic moulding compounds
urea resin laminates	urea or melamine resins, formaldehyde and laminar filler materials	same as phenolic moulding compounds
Polymerizates (thermoplastics)		
	and hydrochloric acid	instable to some organic

polyvinyl chloride, rigid (unplasticized PVC)	acetylene and hydrochloric acid	instable to some organic compounds
polyvinyl chloride, flexible (plasticized PVC)	acetylene, hydrochlorid acid and plasticizer	stability less than for rigid PVC
poloystyrene	ethylene and benzene	instable to most of the organic compounds
polyvinyl acetate	acetylene and acetic acid	(almost only improving or auxiliary agent)
Polyaddition products		
polyurethanes	diisocyanates and dialcohols	instable to concentrated acids
Polyesterification products		
polyester	carboxylic acid or phtalic acid and alcohols	instable to some organic compounds, when unsaturated
epoxy resins	epichlorhydrin, phenols	stable
alkyd resins	maleic acid and phtalic acid, multivalent alcohols	medium resistance to solvents and alcohols

3.2. Properties of Important Plastic Materials

Plastic material	Density in $\text{g} \cdot \text{cm}^{-3}$	Temperature stability in $^{\circ}\text{C}$	Strain in %	Compressive strength δdB in MPa	Bending strength δbB in MPa	Tensile strength δzB MPa
cellulose	1.38	50	30...50	60	60	60...70

nitrate						
phenolic moulding compounds	1.4	125		120...200	50...70	25
phenolic laminates	1.4	125		140	120	40
urea resins	0.014 ...0.28		0.36	200	80	30
urea resin moulding compounds	1.45 ... 1.5	130		240	80	70
urea resin laminates	1.3 ... 1.45	130		150	150	120
rigid PVC	1.38	60	18	80	120	45...60
flexible PVC	1.23 ...1.36					8...25
polystyrene	1.04 ...1.09	60...90	1-20	45...120	70... 130	35...70
polyvinyl acetate				100	100	50
poly-urethane	1.2 ...1.215	<100	≈ 250	30...90	20...65	44...60
polyester	1.2...1.4	≈ 130		150	90	42

epoxy resins

1.2...1.25

60...120

90

135...150

/2

3.3. Applications of Important Plastic Materials

Plastic material	Applications
cellulose nitrate	varnishes and adhesives
phenolic moulding compounds	preservative (see wood-based materials), adhesive and adhesive film, primer paper for coating furniture elements varnishes, moulded parts
phenolic laminates	compression moulded sheets for coating kitchen furniture parts, but also laboratory furniture and similar
urea resins	adhesives, primer paper and decorative overlay for the furniture industry, foamed plastics and insulating materials, varnish resins
urea resin moulding compounds	moulded parts, e.g. for furniture fittings
urea resin laminates	decorative laminated sheets for kitchen furniture, laboratory furniture and damp rooms, decorative overlays for the furniture industry
rigid PVC	films, sheets, moulded parts
flexible PVC	flexible sheet as furniture fittings, decorative overlay and foam sheet, small surface tape for coating furniture veneered stock, overlapping edge bands, foamed plastics, varnishes
polystyrene	compression moulded sheets. furniture films. moulded parts. foamed

	plastics and varnishes
polyvinyl acetate	adhesives, surface coatings, oil-resistant sheets, varnishes
polyurethanes	adhesives, varnishes, rigid foamed plastics as insulation material and for furniture elements (seat shells), structural foam as moulded parts for furniture, semirigid foam for cushions, back-rests and similar, flexible foam for upholstery etc.
Polyester	adhesives, primer paper and decorative overlay, foamed plastics, varnishes
epoxy resins	adhesives and varnishes
alkyd resins	varnishes



[Home](#) > [ar](#).[cn](#).[de](#).[en](#).[es](#).[fr](#).[id](#).[it](#).[ph](#).[po](#).[ru](#).[sw](#)

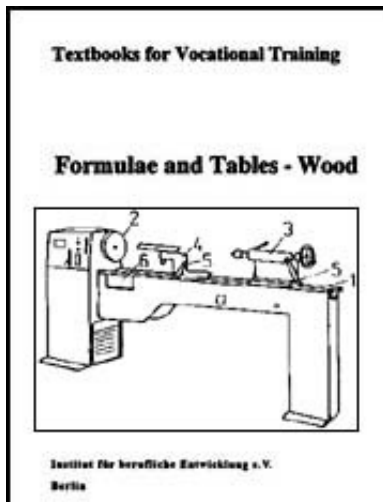

Formulae and Tables - Wood / textbooks for vocational training (GTZ, 122 p.)

4. Glass Materials

 **(introduction...)**

 **4.1. Classification of Glass Materials**

 **4.2. Properties of Glass Materials**

 **4.3. Applications of Glass Materials**

Formulae and Tables - Wood / textbooks for vocational training (GTZ, 122 p.)

Formulae and Tables - Wood / Textbooks for Vocational Training (G12, 122 p.)**4. Glass Materials**

Glass is a transparent, isotropic *) inorganic material.

***) showing the same physical properties in all directions of space**

4.1. Classification of Glass Materials

Classification aspect	Glass grade	Remarks
flat glass	sheet glass	as thin, window and thick glass
	flat glasses with special effects, refined flat glass products	ribbed glass, antique glass, opal glass, frosted glass, plate glass, safety glass, thermoglass panes
fibre-glass materials	glas fibres	coarse glass fibres, textile fibres made of glass
	glass silk	superfine glass fibres

4.2. Properties of Glass Materials

Property	Sheet glass	Glass fibres
density ρ in $\text{g} \cdot \text{cm}^{-3}$	2.4...2.6	2.5
compressive strength δ_{dB} in MPa	800...1000	
tensile strength δ_{zR} in MPa	70 90	850 1000 according to the thickness

mechanical strength δ_B in MPa	70...150	170...3400 according to the thickness
bending strength δ_B in MPa	50...150	170...3400 according to the thickness
temperature stability in °C	≤ 500	-50...+300-C

Dimensions of sheet glass

Glass grade	thickness in mm	width in mm	length in mm
thin glass	0.9...1.6	300...700	1200...1400
window glass	2.0...4.0	300...1800	1000...2000
thick glass	4.5...5.5	400...2010	1050...2550

Dimensions of furniture glass

Glass element	thickness in mm	width in mm	length in mm
sliding doors	3.0...6.0	80...1200	100...1600
revolving doors	5.0...6.0	80...1200	100...1600
panels	3.0...6.0	80...1200	100...1600
glass tops	3.0...5.5	80...1200	100...1600
insertable plates	3.0...7.5	80...600	100...1600

4.3. Applications of Glass Materials

Material	Application	Remarks
thin glass	picture glass	
window	glazing in housing	

window glass	housing construction and social buildings, furniture, glass-houses, stables etc.	
thick glass	shop windows, shop fittings, furniture making	
ribbed glass	shop building, interior work, kitchen furniture etc.	shaping is made during the drawing process
antique glass	interior work, period furniture	old glass is imitated by inclusions, staining and similar
opal glass	hospital windows, office partition walls and similar	toughened or etched panes
frosted glass	shop building, interior work, furniture	an opal glass from the frosted side of which flat splinters are torn out
plate glass	mirrors in flats and social buildings, vehicle construction, furniture making etc.	flat glass covered on one side with a silver layer of ≥ 70 nm thickness; the silver layer is provided with protective layers
safety glass	skylights, glass-roofed courts, roof parts, doors, all-glass walls etc.	as wired glass (rolled in wire cloth), one-layer and multilayer safety glass and compound glass (flat glass panes bonded with transparent foil)
thermoglass panes	housing construction and social buildings	two window glass panes hermetically joined together enclose a space filled with dry air, which prevents misting up of the panes at outdoor

glass fibres	building industry, machine building, textile industry	temperatures down to -15 °C for heat and sound insulation, for reinforcement of plastic building materials
glass silk	structural elements, vehicle construction	processing with, for example, polyester resins into high-strength materials



[Home](#) > [ar](#).[cn](#).[de](#).[en](#).[es](#).[fr](#).[id](#).[it](#).[ph](#).[po](#).[ru](#).[sw](#)

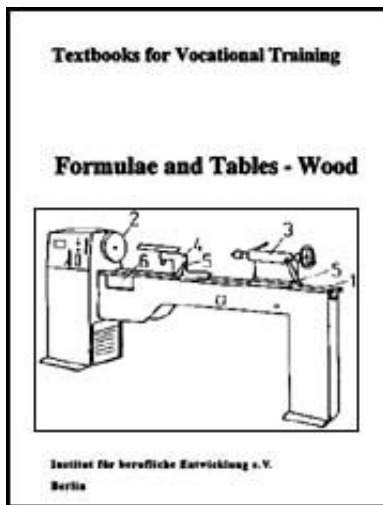

Formulae and Tables - Wood / textbooks for vocational training (GTZ, 122 p.)

➔ 5. Steel

 (introduction...)

 5.1. Classification of Steels

 5.2. Properties of Important Steels

 5.3. Applications of Important Steels

 5.4. Screws and Nails

Formulae and Tables - Wood / textbooks for vocational training (GTZ, 122 p.)

5. Steel

Steels are ferrous materials which regardless of other alloying constituents have carbon contents of less than 2 %.

5.1. Classification of Steels

Classification aspect	Kinds of steels	Remarks
according to the manufacturing process	Bessemer steel Thomas steel open-hearth steel electric steel crucible cast steel	converter process like Bessemer steel open-hearth process made in the electric furnace remelting process in refractory crucibles
according to properties and application	general structural steels steels for mechanical engineering structural steels for special applications high-alloy special steels steels with special electric and magnetic properties tool steels	e.g. sectional steels e.g. screw steel e.g. wear-resistant steels e.g. corrosion-resistant steels e.g. dynamo sheet steels e.g. high-speed steels
according to the composition		
structural steel	unalloyed and alloyed steels	single-alloy steels (one alloying constituent); multiple-alloy steels (several alloying constituents)
tool steels	unalloyed tool steels, low-	

	alloy tool steels, medium-alloy tool steels, high-alloy tool steels	
according to the form of production	sectional steel special profiles bar steel strip steel plate and sheet	e.g. U-steel, > 80 mm high e.g. rails e.g. U-steels, ≤ 80 mm high
	tube wire semifinished products forged pieces	e.g. plate > 4 mm thick, sheet < 4 mm thick seamless or welded various gauges and cross-sections sheet bars, billets etc. hammer and drop forgings

5.2. Properties of Important Steels

Name	Designation of the steel grade	Carbon content C in %	Tensile strength δzB in MPa	Alloying constituents in %
heat-treated steel	C 22	0.18...0.25	500...600	0.3...0.6 Mn, ≤ 0.045 P 0.15...0.35 Si ≤ 0.045 S
	C 35	0.32...0.40	600...720	0.4...0.7 Mn 0.15...0.35 Si ≤ 0.045 P and S each
	C 45	0.42...0.50	650...800	0.5...0.8 Mn

				0.15...0.35 Si ≤ 0.045 P and S each
	C 60	0.57...0.65	750...900	like C 45
	30 Mn 5	0.27...0.34	800...950	1.2...1.5 Mn 0.15...0.35 Si
	37 Mn Si 5	0.33...0.41	900...1050	1.1...1.4 Mn 1.1...1.4 Si
	25 Cr Mo 4	0.22...0.29	800...950	0.5...0.8 Mn 0.9...1.2 Cr 0.15...0.35 Si 0.15...0.25 Mo ≤ 0.035 P and S each
	34 Cr Mo 4	0.30...0.37	900...1050	like 25 Cr Mo 4
	42 Cr Mo 4	0.38...0.45	1000...1200	like 25 Cr Mo 4
	50 Cr Mo 4	0.46...0.54	1100...1300	like 25 Cr Mo 4
	36 Cr Ni Mo 4	0.32...0.40	1000...1200	0.9...1.2 Cr and Ni each ≤ 0.035 P and S each
	34 Cr Ni Mo 6	0.30...0.38	1100...1300	1.4...1.7 Cr and Ni each ≤ 0.035 P and S each
	30 Cr Ni Mo 8	0.26...0.34	1250...1450	1.8...2.1 Cr and Ni each ≤ 0.035 P and S each
case- hardening steels	C 10	0.06...0.12	420...520	0.15...0.35 Si 0.25...0.5 Mn ≤ 0.045 P and S each

	C 15	0.12...0.18	500...650	like C 10
	15 Cr 3	0.12...0.18	600...850	0.4...0.6 Mn 0.5...0.8 Cr 0.15...0.35 Si ≤ 0.035 P and S each
	16 Mn Cr 5	0.14...0.19	800...1100	1.0...1.3 Mn 0.8...1.1. Cr 0.15...0.35 Si ≤ 0.035 P and S each
	20 Mn Cr 5	0.17...0.22	1000...1300	1.1...1.4 Mn 1.0...1.3 Cr 0.15...0.35 Si ≤ 0.035 P and S each
	15 Cr Ni 6	0.12...0.17	900...1200	1.4...1.7 Cr 1.4...1.7 Ni, Mn, Si, P and S like 15 Cr 3
	18 Cr Ni 8	0.15...0.20	1200...1450	1.8...2.1 Cr 1.8...2.1 Ni, Mn, Si, P and S like 15 Cr 3



5.3. Applications of Important Steels





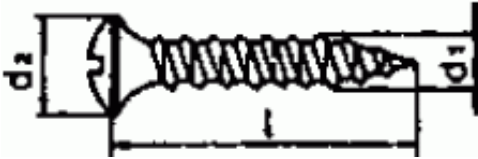

Steel grade	Applications
35 W Cr V 7,80 W V 2	machine blades
100 Cr 2	files

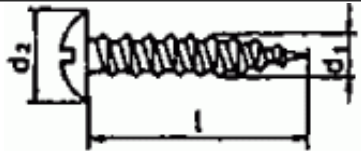
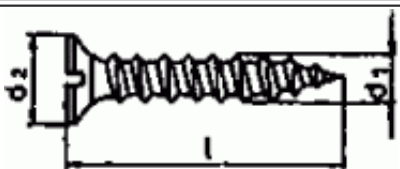
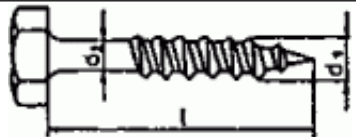
100 Cr 6	measuring instruments, saw blades for metal, cutting tools
64 Si Cr 5,85 Cr 1	saw blades for wood working
110 Mo V 5	metal saw blades
90 Cr 3	cutting tools
140 Cr 2,110 Cr 2,120 W V 4	twist drills
C 115 W 1	screws
C 100 W 1	cutters
C 130 W 2	files, flat drills, countersinks and counterbores
C 90 W 2	circular saw-blades, planing tools, cutters, cutter chain teeth, wood-carving knives
C 80 W 2	hammers, machine bits for wood
C 70 W 2	screw drivers, axes, pliers, vice jaws
C 60 W 3	wood working tools
C 85 W 6	hand saw blades, frame and circular saw blades
X 97 W Mo 3.3	twist drills
X 82 W V 9.2	high-speed wood working tools
X 86 W V 12.2	turning tools, cutters, twist drills
C 35, C 45, 25 Cr Mo 4	screws, nuts

5.4. Screws and Nails

(Material: unalloyed steel with low or medium carbon content, C = ≤ 0.55 %)

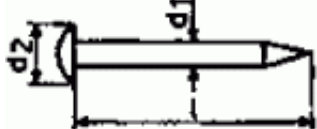
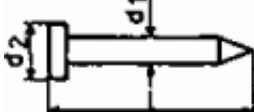
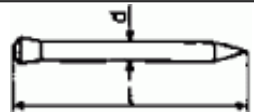
Name	Representation	Dimensions
raised countersunk head wood screws		$d_1 = 1.6...8.0$ mm $d_2 = 3.0...14.5$ mm $l = 8.0...90.0$ mm
cross recessed raised countersunk oval head screw		similar dimensions
slotted round head wood screw		$d_1 = 1.6...8.0$ mm $d_2 = 3.2...16.0$ mm $l = 8.0...90.0$ mm
cross recessed round head wood screw slotted countersunk head wood screw		similar dimensions $d_1 = 1.6...8.0$ mm $d_2 = 3.0...14.5$ mm mm $l = 8.0...90.0$ mm
cross recessed countersunk head wood screw hexagon head cap wood screw		similar dimensions $d_1 = 6.0...12.0$ mm $d_2 \leq d_1$ $l = 30.0...120.0$ mm

countersunk-head nails		$d = 1.4 \dots 6.0 \text{ mm}$ $l = 20.0 \dots 200.0 \text{ mm}$
flat-headed nails		$d = 0.8 \dots 4.6 \text{ mm}$ $l = 8.0 \dots 130.0 \text{ mm}$
button-head nails		$d = 0.8 \dots 2.5 \text{ mm}$ $l = 8.0 \dots 30.0 \text{ mm}$
upset-head nails		$d = 1.0 \dots 3.8 \text{ mm}$ $l = 14.0 \dots 100.0 \text{ mm}$
tin tacks		$d_1 = 1.4 \dots 2.8 \text{ mm}$ $d_2 = 4.0 \dots 10.5 \text{ mm}$ $l = 10.0 \dots 40.0 \text{ mm}$
clout nails		like tin tacks
hardened nails		$d = 1.2 \text{ and } 2.0 \text{ mm}$ $l = 16.0 \dots 50.0 \text{ mm}$
light wood board nails		$d = 3.1.; 3.4 \text{ mm}$



1 = 70.0; 80.0
mm



[Home](#) > [ar](#).[cn](#).[de](#).[en](#).[es](#).[fr](#).[id](#).[it](#).[ph](#).[po](#).[ru](#).[sw](#)

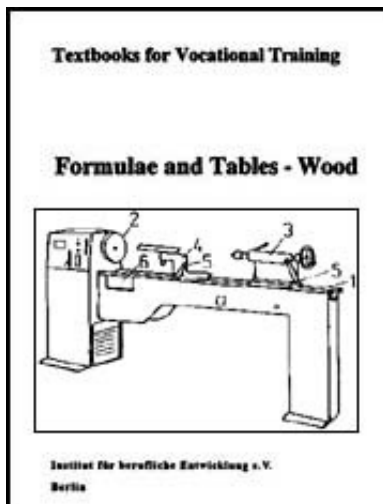

Formulae and Tables - Wood / textbooks for vocational training (GTZ, 122 p.)

➔ 6. Basic Terms of Cutting

 *(introduction...)*

 6.1. Faces and Angles on the Tool

 6.2. Directions of Cutting

 6.3. Cutting Speeds

 6.4. Cutting-Edge Dulling and Cutting-Edge Wear

Formulae and Tables - Wood / textbooks for vocational training (GTZ, 122 p.)

6. Basic Terms of Cutting

The science of cutting deals with the processes, laws and connections for chip-forming working with cutting tools.

6.1. Faces and Angles on the Tool

Term	Symbol	Definition
------	--------	------------

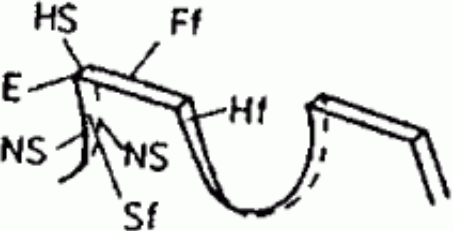
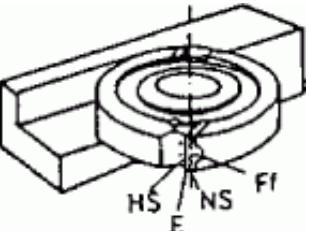
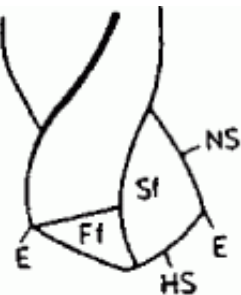
Representation		
<p>primary cutting edge faces on the tool - saw tooth</p> 	HS	line of cut between flank and tool face
<p>secondary cutting edge faces on the tool - milling tool</p> 	NS	cutting edge adjacent to the primary cutting edge
<p>tool face faces on the tool - drilling tools</p> 	Sf	face on the cutting wedge on which the chip is removed
flank	Ff	face on the cutting wedge facing the area of cut produced on the work-piece
flank of the drill point	Hf	face on the tool next to the flank
corner	E	point on the tool at which primary and

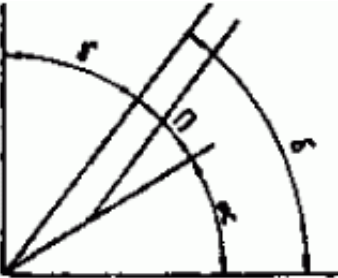
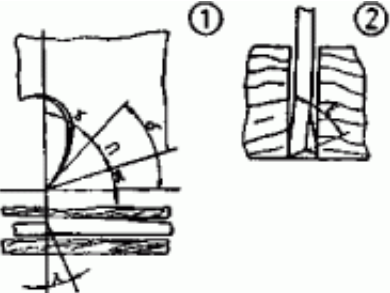
<p>tool orthogonal clearance angles on the tool - planing tool</p> 	<p>α</p>	<p>secondary cutting edges meet angle between flank and tool cutting plane (plane through the cutting edge)</p>
<p>tool orthogonal wedge angle angles on the tool - saw tooth</p> 	<p>β</p>	<p>angle between flank and tool face</p>
<p>tool orthogonal rake</p>	<p>γ</p>	<p>angle between tool face and a vertical to the tool cutting plane $\gamma = 90^\circ - \alpha - \beta$</p>
<p>cutting angle angles on the tool - drilling tools</p>	<p>δ</p>	<p>angle between tool face and tool cutting plane $\delta = \alpha + \beta$</p>

 <p>tool cutting edge inclination angles on the tool - drilling tool</p>	λ	angle between cutting edge and tool reference plane
point angle	ε	angle between primary and secondary cutting edges
drill point angle	ε_B	angle between two primary cutting edges, also called face angle



6.2. Directions of Cutting

The cutting direction of a cutting operation is the direction of motion of the primary cutting edge referred to the grain direction of the solid wood or the board plane of plane materials of wood.

Cutting directions in solid wood

Cutting directions in laminated wood

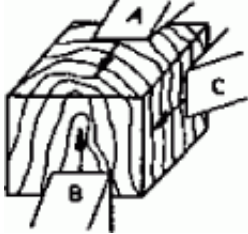
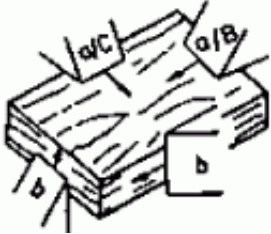
Cutting directions in particle and fibre

		boards
		
A cross-cutting cutting direction vertically to the grain direction; smooth area of cut, crumbly chip, short tool path	b cutting direction vertically to the board plane; approximately like cross-cutting of solid wood	b cutting direction vertically to the board plane; rough area of cut, crumbly chip
B longitudinal cutting cutting direction parallel to the grain direction; rough area of cut, coherent chip, long tool path	a/B cutting direction in board plane, in the direction of the grain direction of the top layer; like longitudinal cutting of solid wood	a cutting direction in board plane; cutting only in the top layer, smooth area of cut, crumbly chip
C transverse cutting cutting direction transversely to the grain direction; rough area of cut, brittle chip	a/C cutting direction in board plane and transversely to the grain direction of the top layer; like transverse cutting of solid wood	

6.3. Cutting Speeds

Term	Symbol	Definition
cutting speed	v	speed at which the cutting edge of a tool performs chip-forming

speed		movements in the workpiece	
		$v = d \cdot \pi \cdot n$	in $m \cdot s^{-1}$
			d = diameter of the cutting circle of the tool
			n = tool speed
feed rate	u	speed at which the workpiece is fed to the stationary tool or the tool is fed to the workpiece clamped in place; unit of measurement: $m \cdot min^{-1}$	

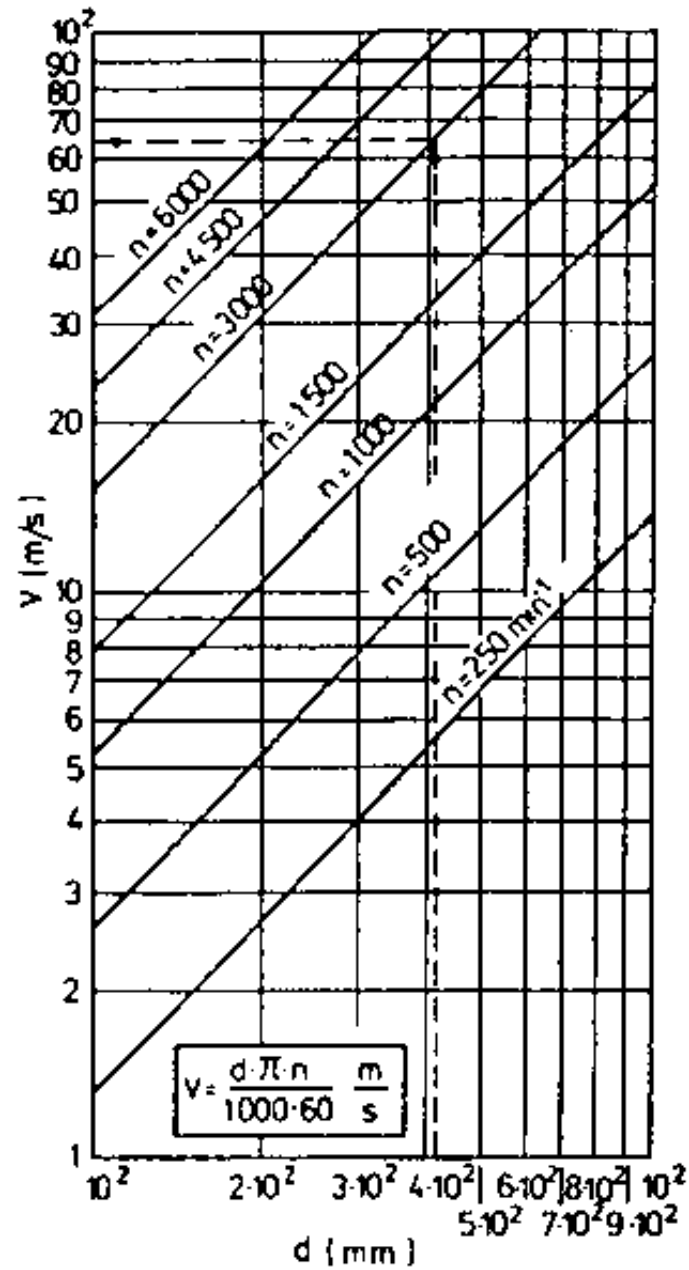

Figure 3 Graph of cutting speeds for circular sawing machines

Example:

Which cutting speed does a circular saw blade having a diameter of 400 mm reach at a speed of rotation of 3000 min^{-1} ?

Solution:

Find the diameter on the lower line, go vertically upwards to the point of intersection with the diagonal for $n = 3000 \text{ min}^{-1}$, from there read off the result horizontally on the left side: $v = 62.8 \text{ m} \cdot \text{s}^{-1}$

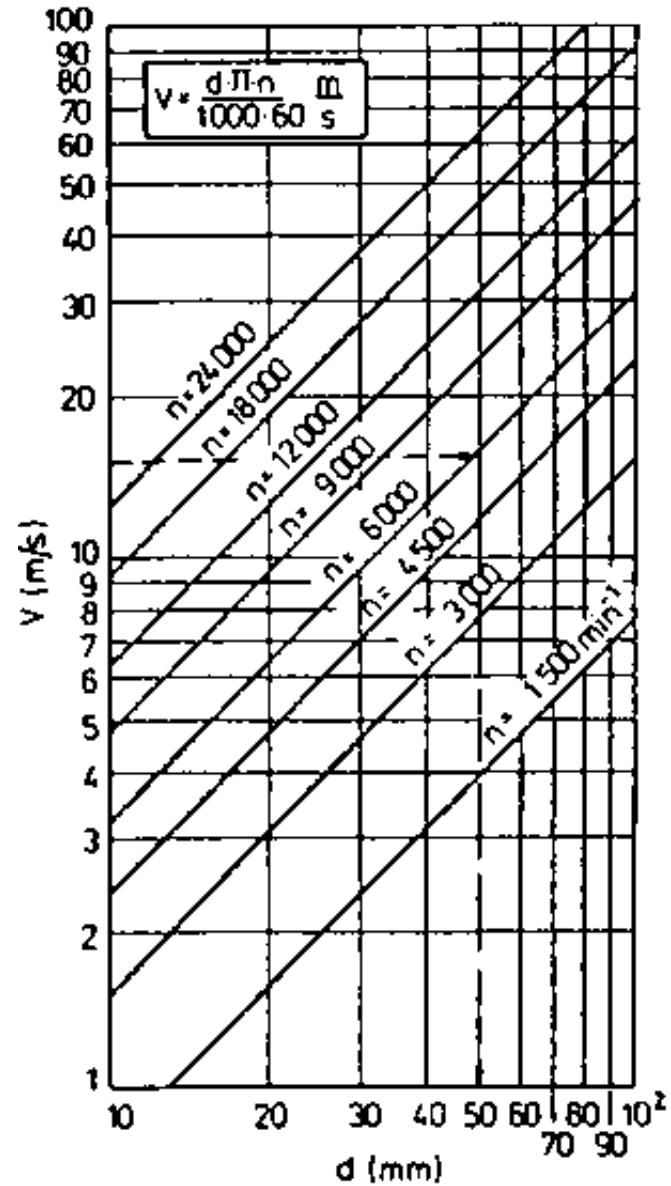

Figure 4 Graph of cutting speeds for fluting machines

Example:

A cutting speed of approx. $15\text{m} \cdot \text{s}^{-1}$ is to be reached; the tool speed is 6000 min^{-1} .

Which tool diameter is to be chosen?

Solution:

Find the value for v on the left side, find horizontally the point of intersection with the diagonal for $n = 6000 \text{ min}^{-1}$, from there drop a perpendicular and read off on the lower line: $d \approx 50 \text{ mm}$.

6.4. Cutting-Edge Dulling and Cutting-Edge Wear

The loss of the original keenness (dressed keenness) of the tool cutting edge and the outer comers in the process of cutting is called dulling, its result is called wear.

Causes of wear

Cause of wear	Effect of wear
<i>Angles on the tool cutting edges</i>	
wedge angle	The cutting forces rise with increasing wedge angle. Therefore, it must be kept as small as possible (taking into consideration the necessary stability).
rake angle	If the rake angle is too small, the consequences will be the same as with a

	too large wedge angle.
clearance angle	Large clearance angles result in a smaller load on the cutting edge (less friction and lower temperature).
<i>Cutting conditions</i>	
cutting speed	High cutting speeds have the effect of increasing the load on the whole cutting wedge. For economical reasons they are to be kept as low as possible.
cutting depth	Keep it as small as possible. Great cutting depths lead to increasing mechanical stress on the cutting edges.
<i>Mechanical stresses</i>	
friction	Excessive roughness of the cutting edge (choice of the proper abrasive tool) results in increased wear at the cutting wedge.
impact load	Mainly at the beginning of cutting when the cutting edge penetrates into the wood for the first time; it results in the loss of the original keenness.
compressive stress	The pressure of the workpiece on the tool is increasing with dulling (sharpening in time is necessary).
<i>Various kinds of stresses</i>	
thermal stress	The friction between workpiece and tool produces temperatures of about 800 °C at the cutting edge. This results in softening of the cutting wedge surface and increased abrasion of material (proper choice of the cutting-edge material of the tool is necessary).
electrochemical stress	The diluted acids in the wood cells form electrolytes. In connection with frictional electricity produced during cutting the cutting-edge material is dissolved by electrolysis.

electroerosion	Spark discharges occur through electrostatic charges during cutting as a result of which particules are torn out of the flank. This formation of craters (increased roghness) favours the mechanical wear.
----------------	--

Forms of wear

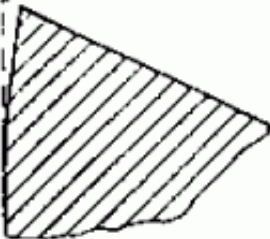
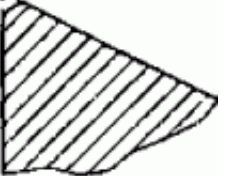
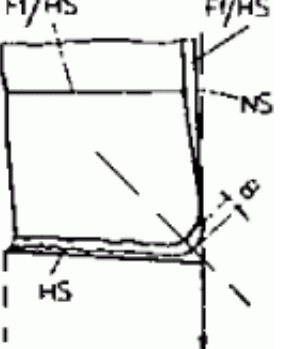
Form of wear Representation	Influences and measurable variables
tool-flank wear 	a result of mechanical wear, thermal load and electroerosion; the wear-land width is the measurable variable. This mark characterizes the size of the regrind, because the cutting edge has to be set back during sharpening so far that the wear mark disappears; wear mark for steel cutting edges $s \leq 0.3 \text{ mm}$.
cutting edge-wear 	caused especially by thermal and frictional stresses; the external radius of the cutting edge is the measure of the cutting-edge wear;
corner wear 	caused by the influence of friction and temperature; with increasing dulling the corner wear rapidly rises;

tool face wear

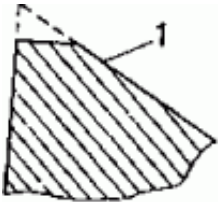

Apart from friction (flowing off chip) and temperature there is above all the electrochemical influence that is at work. The resetting of the cutting edge is the measure of the tool face wear (recommended dimension ≈ 0.15).

crater wear

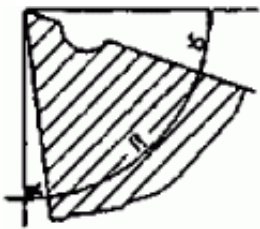

special form of the tool face wear as a result of friction and thermal influence by the flowing off chip

measurable variables of cutting-edge dulling

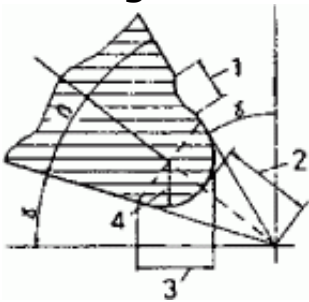

1 crater wear, 2 cutting-edge

*reset, 3 wear-land
width, 4 cutting-
edge rounding*

Development of the cutting-edge dulling

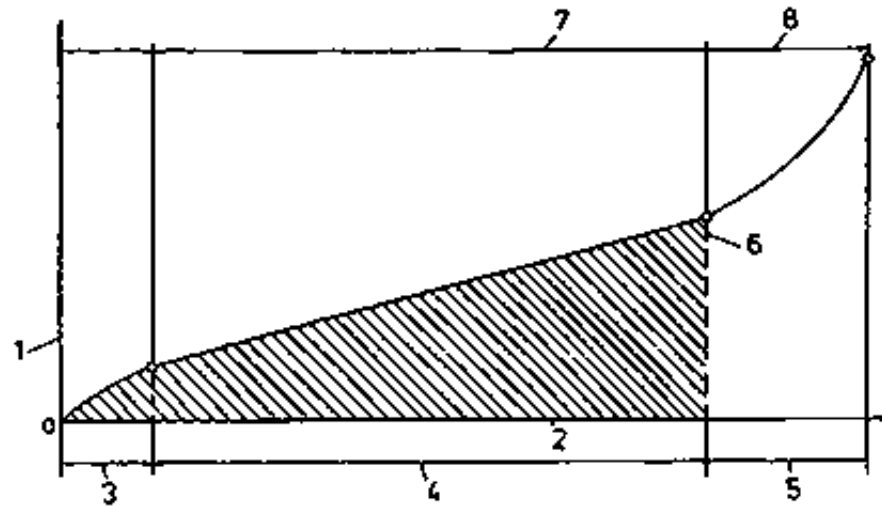

*1 wear-land width, 2 tool path, 3 original
or dressed keenness, 4 working keenness,
5 dull cutting edge, 6 time for sharpening
again, 7 economic tool path, 8 unsuitably
prolonged tool path, 9 time between two
regrinds*

Figure 5 Graph of cutting-edge dulling

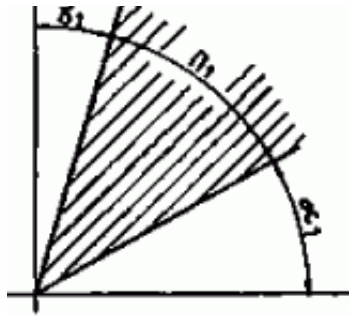

cutting wedge (dressed keenness) with the original cutting-edge angles α_1 , β_1 and γ_1

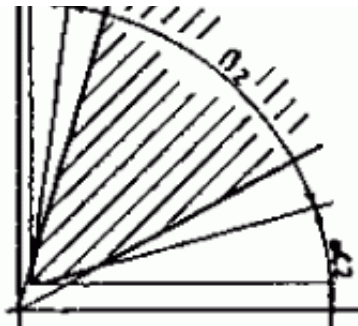

cutting wedge (operating keenness) with the wedge angle β_2 that has become larger by incipient dulling and the tool clearance α_2 that has become smaller and the tool orthogonality rate γ_2

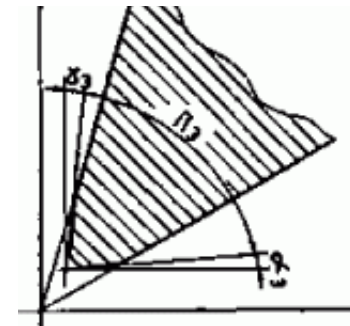

cutting wedge (advanced stage of dulling) with β_3 that has become still larger and α_3 and γ_3 that have become still smaller

Dulling period of the cutting edge

Term	Symbol	Definition	Connections
tool life	T	pure operating time of a cutting edge between two regrinds	$T = \frac{S}{W_t}$ <p>S = tool path W_t = path of cut per unit of time</p>
tool path	S	distance travelled by the cutting edge cutting in the material between two regrinds	the tool path in connection with the tool life is an important parameter for the economical use of machine tools



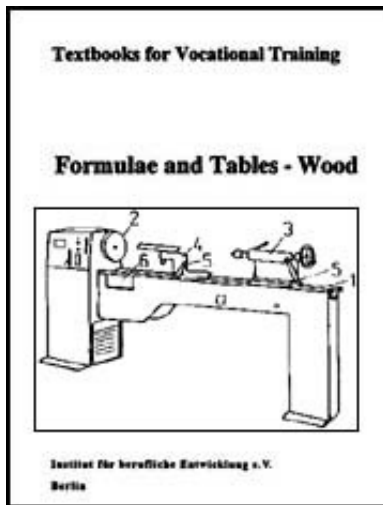

Formulae and Tables - Wood / textbooks for vocational training (GTZ, 122 p.)

7. Hand Tools

 **(introduction...)**

 **7.1. Measuring and Marking Tools**

 **7.2. Sawing Tools**

 **7.3. Planing Tools**

 **7.4. Mortising and Ripping Tools**

 **7.5. Drilling and Boring Tools**

 **7.6. Rasps and Files**

 **7.7. Other Tools**



Formulae and Tables - Wood / textbooks for vocational training (GTZ, 122 p.)

7. Hand Tools

Hand tools are individually guided working tools by means of which action is taken on the object of work (workpiece) when the respective operations are carried out.

7.1. Measuring and Marking Tools

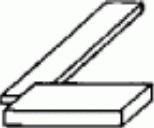
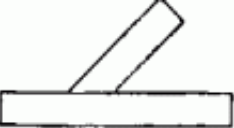
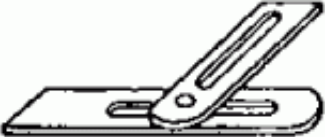
Marking tools serve the purpose of transferring sizes to the workpiece and of marking the transferred sizes.

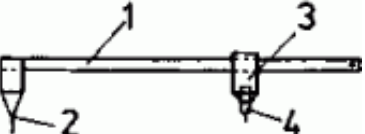
Tool Representation	Construction and use
back square 	The back square serves for marking out right angles. It has a shorter, thicker part (head piece, stop) and a longer, thinner blade (rail). It consists of wood or steel.
mitre rule 	Mitre rules serve to mark out 45° angles, with the shorter leg serving as stop.
bevel gauge 	Bevel gauges are back squares where both legs can be adjusted to each other as desired (angles of any size can be formed).
scratch gauge 	The scratch gauge serves for marking out straight scribed linears parallel to one side of the workpiece. The stop is adjustable and is arrested by wedges or screws.
Compasses 	The compasses serve for taking and transferring sizes and for marking out circular arcs.
<i>1 guide beam, 2 centring point, 3 slide, 4 pencil holder</i>	

vernier caliper with depth gauge

Length measurements are possible by placing the

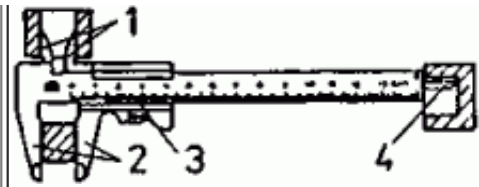

workpiece between graduation carrier and sliding member. The diameter of bore holes can be measured with the sensing elements. For determining the depth of bore holes and similar the depth gauge is used.

1 measuring surface of the graduation carrier, 2 measuring surface of the sliding member, 3 sensing element for determining the diameter of bore holes, 4 depth gauge

outside caliper



caliper-like measuring instrument (caliper) with inwardly bent legs for tracing and comparing diameter, lengths and tick-nesses

inside caliper

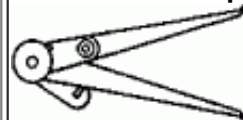

caliper-like measuring instrument (internal caliper gauge) with outwardly bent leg points for tracing and comparing bore holes, counterbores and similar

radius gauge/profile gauge



Radius gauges are templates like profile gauges and similar, by means of which the profiles of boards, but also of narrow surfaces can be checked.

7.2. Sawing Tools

Hand saws have triangular teeth and consist of tool steel. We distinguish between span-web saws and saws without span web.

Parts of a saw without span web

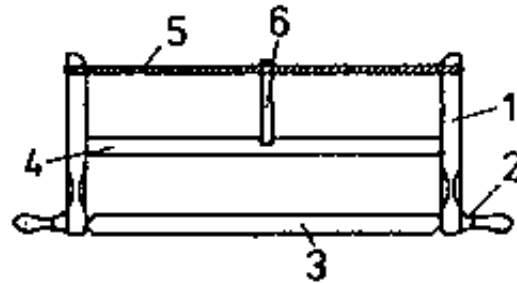

*1 saw arm, 2 adjustable handle, 3 saw blade, 4 connecting strip
5 tensioning part, 6 lock*

Figure 6 Parts of a span web saw

Parts of a saw without span web

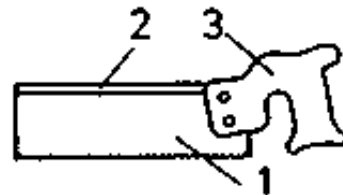

1 saw blade, 2 back reinforcing part (steel rail), 3 handle

Figure 7 Parts of a saw without span web



Kinds and dimensions of span-web saws (frame saws)



Kind of saw	Saw blade		thickness in mm	Saw pitch in	Setting width*) in	Applications
	length in mm	width in mm				

				mm	mm	
cabinet saw	700;800	25	0.7	5	0.4	for work in grain direction; trimming, cutting off
pad saw	700:800	40	0.7	4	0.25	finer cuts across the grain direction, for wood-based materials
fret saw	700	10	0.7	3	0.25	for sawing out bends

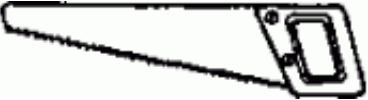
***) tooth set: alternate bending out of saw teeth to reach a cutting width which is greater than the blade thickness.**

Kinds and dimensions of saws without span web

Kind of saw	length in mm	Saw blade width in mm	thickness in mm	Saw pitch in mm	Setting width in mm	Applications
foxtail 	250-500		0.7-0.8	3-5	0.2-0.25	fine work, cutting of plywood and other materials
keyhole saw 	300		1.0	4	0.35	for cutting out openings
fine saw	250	65	0.5	1.5	0.15	especially for mitre cuts

						
back saw	300	100	0.7	3-4	0.2	like fine saw
						

nest of saws: Saw blades of all span-web saws known so far can be fixed to a handle as required.

Tool geometry of hand saws

Kind of saw	Angle at the a tool cutting edge in °		
	α	β	γ
cabinet, pad, fret saws	45	70	-25
foxtail saw, keyhole saw	60	60	-30
fine saw	65	50	-25
back saw	10	60	20

Recommendations for maintenance and use

Untension frame saws after use, turn the row of teeth inwards during transport, saturate wooden parts with linseed oil varnish or with polish to prevent impurities from getting into them; keep hand saws in a hangig position, clean the saw blade from impurities by means of petroleum or similar and protect it against rust by means of acid-free grease. Cover the teeth of saws without span web during transport and storage so that no injuries are possible.

7.3. Planing Tools

Parts of a plane

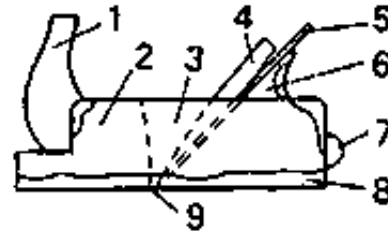

1 nose, 2 plane body, 3 chip hole, 4 clamping wedge, 5 plane knife, 6 hand guard, 7 impact button, 8 plane face, 9 chip opening

Figure 8 Parts of plane

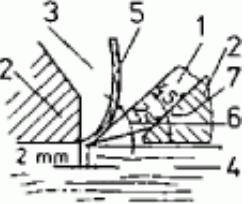
Kind of plane	Cutting angle δ in $^{\circ}$	Applications
finish plane 	45	without flap; coarse chip removal, for flattening and rough smoothing, chip thickness up to 1 mm
<i>1 plane knife, 2 plane body, 3 chip hole, 4 workpiece, 5 chip, 6 wedge angle, 7 cutting angle, 8 flap of the plane</i>		
double iron plane	45	with flap, smoother surface than with the finish plane, for flattening of finished surfaces

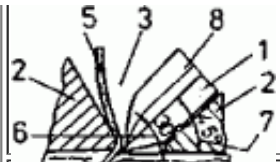

1 plane knife, 2 plane body, 3 chip hole, 4 workpiece, 5 chip, 6 wedge angle, 7 cutting angle, 8 flap of the plane

trying plane

45

with flap; basically a long double plane; for dressing of surfaces, for edging and jointing of narrow surfaces

smoothing plane

49

with flap; for smoothing of surfaces, for planing of end surfaces

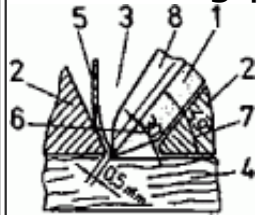

1 plane knife, 2 plane body, 3 chip hole, 4 workpiece, 5 chip, 6 wedge angle, 7 cutting angle, 8 flap of the plane

rabbit plane

45...48

simple rabbit plane without flap, double rabbit plane with flap; for replaning and resmoothing of rebates



Recommendations for maintenance and use

Regularly clean the plane iron and the face of the plane; when putting the plane down, lay it on its side; the face of the plane must be even, if not, dress it and

afterwards oil it slightly; replace faces of planes that are excessively worn by new ones; if the plane is blocking, check whether the flap is tightly fitting, the wedge is fitting or whether the pressure of the wedge is properly acting on the lower part of the plane iron.

7.4. Mortising and Ripping Tools

Mortising and ripping tools are hand tools for chiselling, mortising and turning operations.

Parts of the mortising and ripping tools

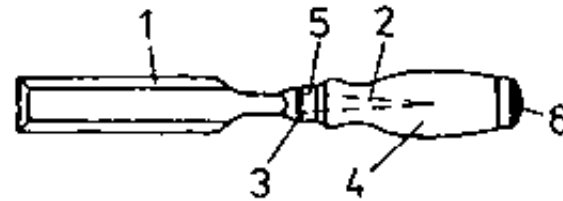

*1 blade, 2 tang, 3 shoulder or collar, 4 haft, 5 clamp,
6 impact button*

Figure 9 Parts of the mortising and chiselling tools

Kinds and dimensions of the mortising and ripping tools

Tool		Dimension of the blade		Applications
		width in mm	thickness in mm	
ripping	light	4...50	2.5...4	for mortising recesses, for recessing fittings,

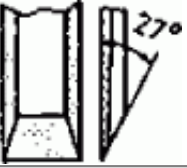
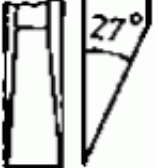
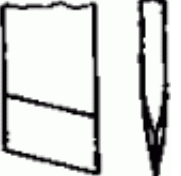
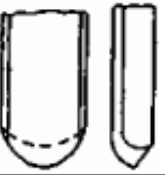
chisel 	medium heavy	6...40 20...35	3.5...4.2 4.2...5	for mortising recesses at an acute angle
mortise chisel 		2...26	12...15	for mortising orftenon holes and similar
turning chisel, flat 		4...50	3.5; 4.5	making of turned bodies, soft wood working, finishing work; $\alpha = 10...20^\circ$ $\beta = 20...30^\circ$
turning chisel, hollow 		4...50	3.5...6	hard wood working, roughing work; $\alpha = 10...20^\circ$ $\beta = 40...50^\circ$

Recommendations for maintenance and use

The tool must be clean and sharp; always clamp the workpiece, always chisel on the carpenter's bench plate, not on the collets; further hints: like plane irons.

7.5. Drilling and Boring Tools



Drills are tools for making round holes.

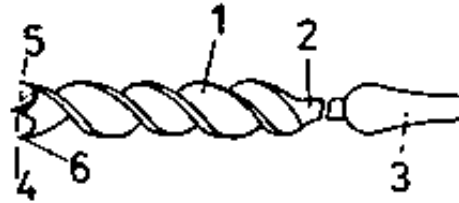



Parts of a drill



1 drill scew, 2 parallel shank, 3 squared end, 4 centre-point with in-feed thread, 5 cutting tool tip, entering tap

Figure 10 Parts of a drill

Drilling and boring tool	Dimensions in mm		Applications
twist drill with roof-shaped point 	diameter thread length	3.0...8.3 42...70	for drilling into hard wood and end-grained wood, into wood-based materials and metals
twist drill with a spiral flute 	diameter overall length	2...12 120...170	for drilling into end-grained wood
auger bit 	diameter length	6...30 185...250	for deep drilling into soft and hard wood

 <p>twisted auger</p>	<p>diameter length</p>	<p>3...10 125...160</p>	<p>mainly for predrilling for woods screw into soft wood; produces high splitting effect</p>
 <p>centre bit</p>	<p>diameter length</p>	<p>6...50 80...140</p>	<p>drilling into cross pieces</p>
 <p>gimlet</p>	<p>diameter length</p>	<p>2..10 90...200</p>	<p>for predrilling screw and nail holes, mainly into soft wood</p>
 <p>wood countersinks</p>	<p>diameter length</p>	<p>16 and 20 100</p>	<p>for reaming bore holes, these get a funnel-shaped bevel</p>

Aspects for the drill selection

Feature	Application
with square shank	for breast drill
with parallel shank	for drill chuck and machine
with entering tap	for cross-piece drilling
with chip groove	for deep drilling
with roof-shaped point	for non-fibrous materials and end-grained wood

with centre point	for exact advance
with feed thread	for manual work
without feed thread	for machine work
with short die head	for flat drilling

Recommendations for maintenance and use

Drilling and boring tools must be clean and well sharpened. When storing them, protect cutting parts. Keep them safe in a hanging or lying position in cabinets or cases, they must not contact each other. Remove impurities with hot water or petroleum after use, slightly grease them with acid-free grease against rust.

7.6. Rasps and Files

Rasps and files are hand tools for flattening and smoothing. Rasps have coarser cutting edges, files have finer ones.

Parts of rasps and files

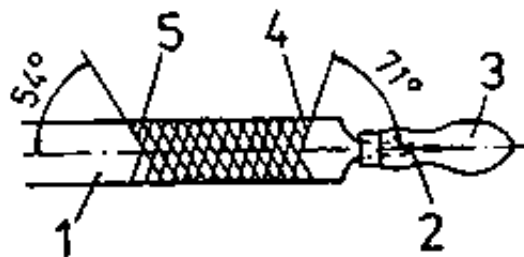

1 file blade, 2 file tang, 3 file handle, 4 upcut, 5 undercut

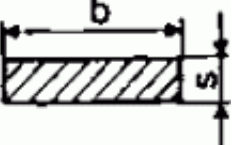
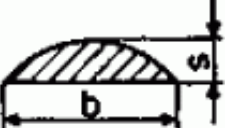
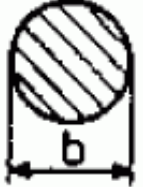
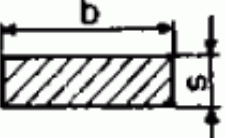
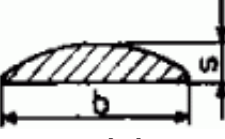

Figure 11 Parts of rasps and files

Kinds and dimensions of rasps

Tool	Length in mm	Cross-section in mm	Application
flat rasp  <i>1 width, 2 thickness</i>	200...350	20 × 5...36 × 8	Rasps serve for coarse smoothing of round portions and recesses.
half-round  <i>1 width, 2 thickness</i>	200...300	18 × 6...30 × 10	
round rasp  <i>1 width</i>	200...250	diameter 8 and 10 mm	

Kinds of dimensions of files

Tool	Length in mm	Cross-section in	Application
------	--------------	------------------	-------------

		mm	
rectangular file  <i>1 width, 2 thickness</i>	200 and 250	20 × 3.5; 25 × 4	for fine smoothing of round portions and recesses, reworking of rasped surface
flat/round file  <i>1 width, 2 thickness</i>	like rectangular file		
triangular file  <i>1 width</i>	100...200	side length 6...17	especially as saw sharpening file, edge angle 60°, edges slightly rounded for machining the tooth gullet

Special kinds, e.g. as special saw and mill files



Recommendations for maintenance and use

Use only tools the tangs of which are straightly and firmly seated in the haft (stab injuries). Work in grain direction, if possible. Choose tooth spacing*) according to

the wood quality (use files with coarse cut for soft or damp wood). Clean the tools from impurities by dipping them into hot water, brush them with a hand brush. Clean metal files with file brushes made of fine copper wires.

***) Cuts: Cutting edges lying closely one after the other and recessed or cut into the metal base body by machine.**

7.7. Other Tools

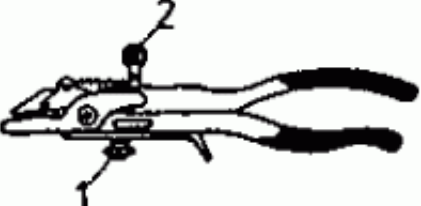
Tool	Application
glass cutter 	for cutting glass panels. The glass is scratched under slight pressure by means of a diamond particle or a hard metal tip.
setting iron 	for setting hand saws. The tool head provided with the recesses may have a varying number of notches; the notches are of different widths and correspond to the different thicknesses of the saw blades.
setting pliers  <i>1 adjusting screw for tooth depth 2 adjusting screw for setting width</i>	for setting hand and machine saw blades. The setting pliers are designed for various tooth depths and blade thicknesses; setting depth and setting width can be adjusted. The setting pliers allow more exact working than the setting iron.

setting pliers for tooth depths of up to 8 mm and blade thicknesses of 0.3...1.5 mm

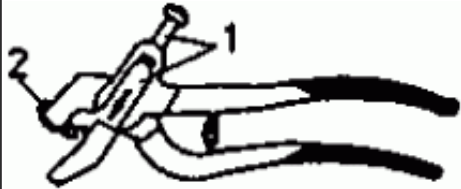

1 adjusting screw for tooth depth 2 adjusting screw for setting width

setting pliers for tooth depths of up to 15 mm and blade thicknesses of 0.5...3.0 mm

hone



for honing (smoothing) the cutting edge.

Natural as well as synthetic stones are used, with the latter mostly having on both sides different grain sizes (rough honing, fine reworking). Water and oil are used as lubricants.

scraper

for smoothing hard wood surfaces.

Chip removal by sharp burrs on the longitudinal edges; 0.8 - 3 mm thick, made of tool steel

