

[Home](#) > [ar.cn.de.en.es.fr.id.it.ph.po.ru.sw](#)

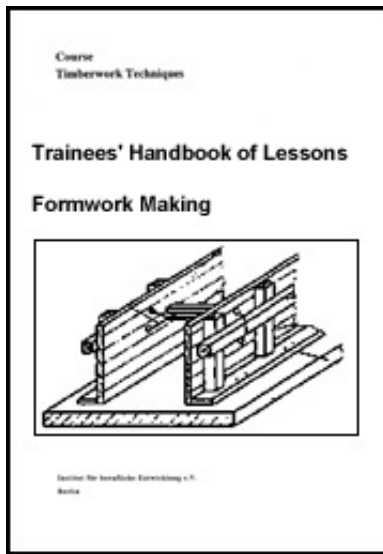

➔ **Formwork Making - Course: Timberwork techniques. Trainees' handbook of lessons (Institut für Berufliche Entwicklung, 14 p.)**

(introduction...)

1. Purpose and Use of Formwork

2. Functional and Load Requirements of Formwork

3. General Construction of Formwork

4. Types of Formwork

5. Preparation and Aftertreatment of Formwork



[Home](#) > [ar.cn.de.en.es.fr.id.it.ph.po.ru.sw](#)

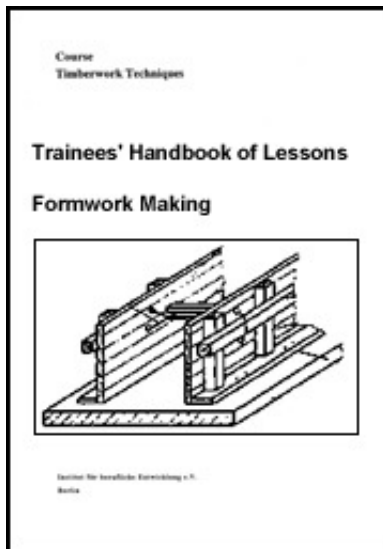

Formwork Making - Course: Timberwork techniques. Trainees' handbook of lessons (Institut für Berufliche Entwicklung, 14 p.)

➔ **(introduction...)**

1. Purpose and Use of Formwork

2. Functional and Load Requirements of Formwork

3. General Construction of Formwork

4. Types of Formwork

5. Preparation and Aftertreatment of Formwork

**Institut fr berufliche Entwicklung e.V.
Berlin**

Original title:

**Arbeitsmaterial fr den Lernenden
"Herstellen von Schalungen"**

Author: Peter Wehrmann

First edition © IBE

**Institut fr berufliche Entwicklung e.V.
Parkstrae 23
13187 Berlin**

Order No.: 93-35-3601/2



[Home](#) > [ar](#).[cn](#).[de](#).[en](#).[es](#).[fr](#).[id](#).[it](#).[ph](#).[po](#).[ru](#).[sw](#)

 **Formwork Making - Course: Timberwork techniques.
Trainees' handbook of lessons (Institut fr Berufliche
Entwicklung, 14 p.)**

 **(*introduction...*)**

  **1. Purpose and Use of Formwork**

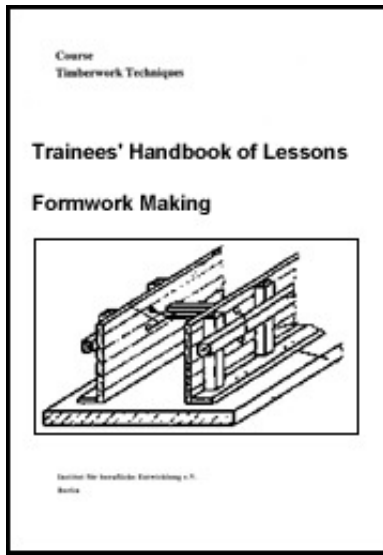

-  **2. Functional and Load Requirements of Formwork**
-  **3. General Construction of Formwork**
-  **4. Types of Formwork**
-  **5. Preparation and Aftertreatment of Formwork**

1. Purpose and Use of Formwork

The formwork serves as mould for concrete structural components unless such mould is provided by the soil, other structural components, etc. It moulds the placed fresh concrete, which in this stage normally is viscous, to the shape specified in the drawing.

Consequently, the formwork must already be available when the necessary steel reinforcement and concrete mix are placed. Proper making of formwork decides on the accuracy to size, strength and surface finish of the concrete components. Formwork is required wherever monolithic concrete and reinforced concrete structures or structural components are constructed, such as for

- solid structures (foundations, columns...),**
- structures with special functions (containers, chimneys, hydraulic structures ...),**

- **structures to meet great statical requirements (bridges, towers...),**
- **reconstruction of structures,**
- **public buildings and structures of irregular arrangement.**

Generally, each formwork is of provisional nature and is to be removed after hardening of the concrete placed. The formwork is not to be built as strong as possible but as strong as necessary only!

Therefore, formwork stripping must always be kept in mind when erecting the formwork.

To avoid unnecessary difficulties of work and prevent damage from formwork parts, the following recommendations should be followed:

- **Do not drive in too many nails.**
- **Use only as many timbers, braces, tie wires, etc. as necessary.**
- **Consider, which board, panel or squared timber is to be stripped first, to fix them so as to permit easy removal in the proper sequence.**

Formwork making guaranteeing the necessary strength but also considering aspects of economical use of material and easy formwork stripping calls for extensive specialized knowledge of the direction of forces when placing the concrete mix.

Improperly made formwork, which gives way or breaks when the concrete is placed, results in heavy material damage or, in the worst case, may cause serious injury of persons.

On the other hand, an excessively strong formwork requires high physical efforts of the persons stripping the formwork and normally results in the complete destruction of the formwork parts.



[Home](#) > [ar](#).[cn](#).[de](#).[en](#).[es](#).[fr](#).[id](#).[it](#).[ph](#).[po](#).[ru](#).[sw](#)

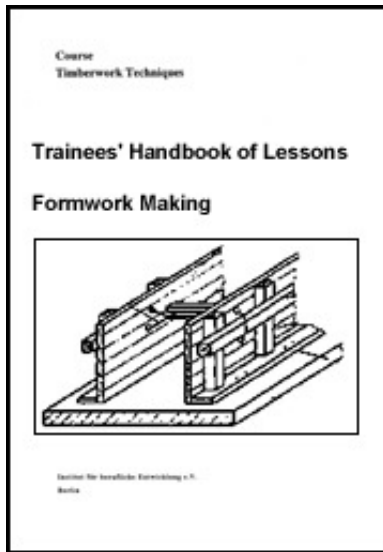

 **Formwork Making - Course: Timberwork techniques. Trainees' handbook of lessons (Institut für Berufliche Entwicklung, 14 p.)**

 **(introduction...)**

 **1. Purpose and Use of Formwork**

 **➔ 2. Functional and Load Requirements of Formwork**

 **3. General Construction of Formwork**

 **4. Types of Formwork**

 **5. Preparation and Aftertreatment of Formwork**

2. Functional and Load Requirements of Formwork

Formwork functions

The formwork is the main means of work in the moulding process of the concrete. Basically the process of formwork making has to meet the following requirements:

- The structural component to be produced is to be moulded with the

projected dimensions keeping the admissible tolerances.

- The dead loads of the fresh concrete and of the reinforcement as well as the temporary load of persons and working tools must be safely resisted and carried off to the soil or supporting members of the structure.**
- The concrete must be protected against too high or too low temperatures as well as vibrations.**
- The thin concrete mix must not flow out of the formwork.**
- The future concrete component must have a surface finish meeting the required quality after stripping.**
- The placement of necessary steel reinforcements must be easily possible during the erection of the formwork.**
- Stripping of the concrete components produced must be uncomplicated.**

What are the basic principles of formwork making?

Loading of vertical formwork

Vertical formwork is used for strip foundations, concrete walls and columns.

Immediately after placement in the formwork until achievement of its inherent stability, the concrete mix, under the effect of its own load and of compaction by

vibration, exerts lateral pressure on the formwork which is called lateral pressure of the concrete mix.

The lateral pressure of the concrete mix depends on the following factors:

- Composition and properties of the concrete mix (density, type of cement, quality of concrete),**
- concrete placing technology (concreting speed, compaction, vibration depth, total height of the concrete mix)**
- ambient conditions (temperature, air humidity).**

Tie wires (tie rods) are used to take up the lateral pressure of the concrete mix. They are to be included in the formwork project.

The maximum lateral load with external vibration occurs at the foot of the formwork and with internal vibration above the foot.

In addition to the lateral pressure of the concrete mix, the concrete mix also produces buoyant forces which may cause lifting of the formwork. This can be the case particularly with foundation formwork. To avoid this, the formwork is to be anchored in the subsoil.

Another way is loading the formwork by means of concrete parts.

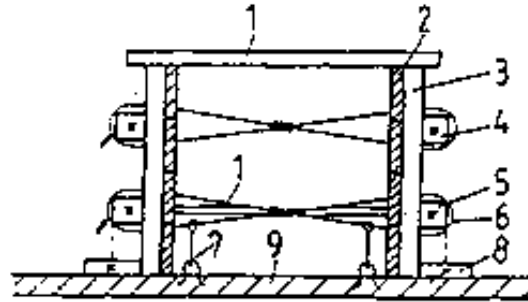

Figure 1 Formwork tying in the subsoil by means of tie wires

1 stulls, 2 sheeting boards, 3 post, 4 upper waler, 5 lower waler (additionally supported) 6 tie wire, 7 tying in the concrete bottom (tie wire), 8 thrust-board, 9 concrete bottom

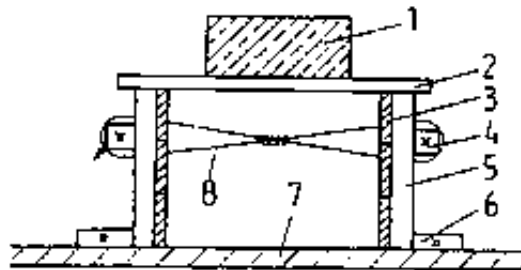

Figure 2 Formwork tying by loads on the formwork

1 concrete sheeting, 2 formwork bearer, 3 main bearer, 4 columns, 5 formwork pressure (surface pressure), 6 carrying off to the columns (linear)

What does the terms "lateral pressure of the concrete mix" mean?

Loading of horizontal formwork

Horizontal formwork is used for ceilings and beams. Horizontal formwork is subjects to vertical loads which are to be carried off to solid subsoils through formwork bearers and main bearers as well as columns.

Vertical loads are produced by

- the concrete mix weight in the specified height,**
- reinforcements,**
- concrete cones on the concrete pouring spot,**
- concrete pouring impact on the formwork,**
- persons and working tools,**
- dead load of the formwork.**

In addition to vertical loads, there are also horizontal loads which are produced by:

- wind effects**
- inclined position of columns,**
- backing up, etc.**

The horizontal forces are taken up by auxiliary structures, such as braces and struts, or rigid connection to existing structural components, such as walls and columns.

Formwork walls and columns are to be backed up from all sides!

Through which components are vertical loads carried off?



[Home](#) > [ar](#).[cn](#).[de](#).[en](#).[es](#).[fr](#).[id](#).[it](#).[ph](#).[po](#).[ru](#).[sw](#)

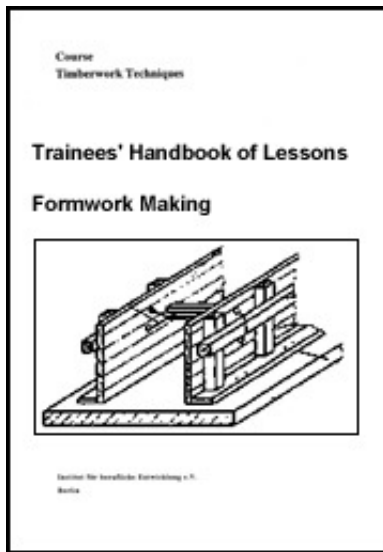

 **Formwork Making - Course: Timberwork techniques. Trainees' handbook of lessons (Institut für Berufliche Entwicklung, 14 p.)**

 **(introduction...)**

 **1. Purpose and Use of Formwork**

 **2. Functional and Load Requirements of Formwork**

 **➔ 3. General Construction of Formwork**

 **4. Types of Formwork**

 **5. Preparation and Aftertreatment of Formwork**

3. General Construction of Formwork

The formwork sheeting (also called formwork shell)

The formwork sheeting is in direct contact with the concrete and can be considered as mirror image of the concrete components to be produced.

It is the moulding element of the formwork and has the greatest influence on the quality of the concrete surface.

The formwork sheeting has to resist heavy stress. It takes up surface pressure and carries it off to lineary acting supports.

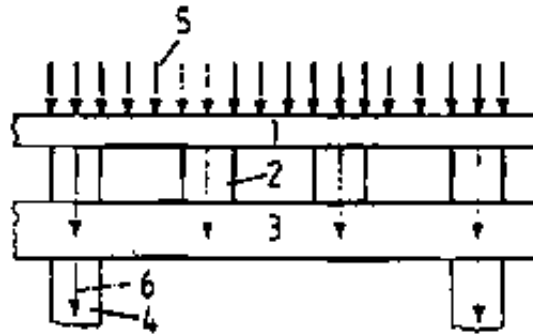

Figure 3 Formwork pressure distribution

1 formwork sheeting, 2 formwork bearer, 3 main bearer, 4 columns, 5 formwork pressure (surface pressure), 6 carrying off to the columns (linear)

It is typical of the formwork sheeting that, because of the heavy stress and direct contact with the concrete, it is the part of the formwork to wear first.

Sheeting boards and prefabricated wooden panels can be used as sheeting material.

Formwork sheeting of individual boards normally consists of 25 mm thick and approximately 140 mm wide boards. The heartwood side must always lie towards the concrete. Sheeting boards have great advantages because of their easy workability, such as by sawing, planing, boring and nailing.

Disadvantages are:

- the high expenditure of working time required for formwork making,
- the short service life,
- loss by waste wood.

In the event of repeated use of formwork of the same design, such as for foundation strips, sheeting panels can be prefabricated from individual boards using squared timbers as frame.

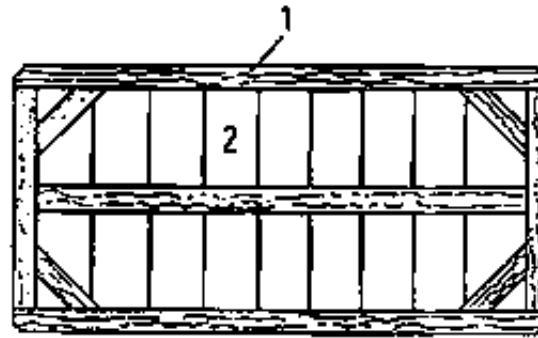

Figure 4 Sheetting panel for repeated use

1 sheetting panel frame, 2 holes for steel wedges

The sheetting panels are prefabricated in a workshop. The advantage of sheetting panels is that they considerably reduce the time required for the erection of the formwork on site.

The disadvantages of sheetting panels in terms of service life are similar to those of sheetting boards.

Normally both types of formwork sheetting are used on site in a combined manner.

What are the common types of formwork sheeting?

The formwork bearers

The formwork bearers directly support formwork sheeting. They carry off the forces through falsework structures to supporting members, the soil and formwork ties. The formwork bearers normally consist of squared timbers. The cross sections of the beams depend on the loads to be resisted. Because of their good workability, wooden beams have a wide field of application. In addition to wooden beams, prefabricated steel parts (steel beams, clamps etc.) are also used. Clamps are mainly used for column formwork.

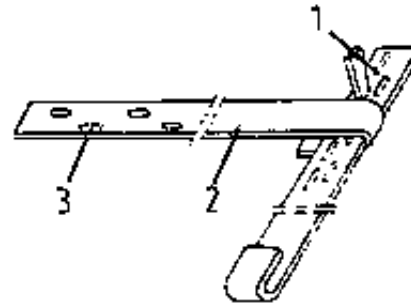

Figure 5 Steel clamp corner point for column formwork

1 steel wedge, 2 clamp, 3 holes for steel wedges

The formwork ties

With vertical formwork, the horizontally acting formwork pressure is mostly taken up by tying the two form-work faces to each other by formwork ties. It is done by

slinging a steel wire (3.1 mm to 4.2 mm, annealed) around the formwork bearers, guiding it through boreholes in the formwork sheeting and tightening it by twisting. Immediately near the tie wire a stull (of wood or concrete) is to be mounted to maintain the necessary width of formwork.

When placing the concrete, the stull (if made of wood) is to be remove because the concrete mix assumes the bracing function (pressure) (See Fig. 1 and Fig. 2).

Another way of bracing is screwing by means of steel screws.

The elements of falsework structures

Falsework structures are those parts of the formwork which take up and carry off the load from the formwork sheeting and formwork bearers.

The main elements of such formwork structures are columns and main bearers.

The column takes up the load directly from the formwork bearer and carries it off.

Round timber braces and specially made metal tube structures adjustable in height may be used as columns.

In the case of round timber columns, double wedges are to be placed at the foot to prevent lowering of the formwork when stripping.

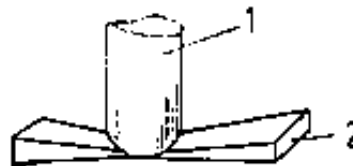

Figure 6 Column foot with wedge support

1 column, 2 wedge support

Other falsework elements are the main bearers which are horizontally arranged. One main bearer takes up the load from several formwork bearers and carries it off to the columns. Main bearers can be made of amply dimensioned squared timbers. But they may as well consist of metal tube structures of lattice type.

Lattice-type metal tube structures are indispensable for big widths where columns cannot be laced at close intervals.

Further falsework elements are bracing members which are required for both vertical and horizontal form-work. They ensure that the admissible unsupported length of columns is kept and secure the formwork against displacement and canting.

Their arrangement and fixing according to the project is decisive for the stability of the formwork.

Bracing members may be:

- boards, squared timbers and round timbers,**
- metal tube structures, steel ropes and steel sections.**

How is dimensional inaccuracy by compression of the formwork prevented by means of tie wires?

What is a falsework structure?



[Home](#) > [ar](#).[cn](#).[de](#).[en](#).[es](#).[fr](#).[id](#).[it](#).[ph](#).[po](#).[ru](#).[sw](#)

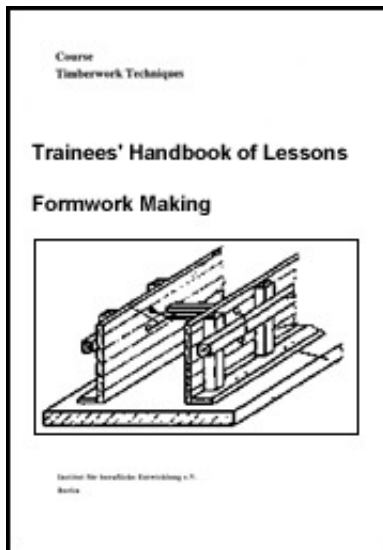

 **Formwork Making - Course: Timberwork techniques. Trainees' handbook of lessons (Institut für Berufliche Entwicklung, 14 p.)**

 **(introduction...)**

 **1. Purpose and Use of Formwork**

 **2. Functional and Load Requirements of Formwork**

 **3. General Construction of Formwork**

 **➔ 4. Types of Formwork**

 **5. Preparation and Aftertreatment of Formwork**

4. Types of Formwork

4.1. Foundation Formwork

Foundation formworks can be designed in various ways. Basically there is a difference between formwork for individual foundations, normally designed as

socket foundations, and formwork for strip foundations. The type of design is dictated by the size, mainly by the height of the foundation formwork.

The formwork for individual foundations is similar to column formwork and the formwork for strip foundations is similar to the formwork.

Normally sheeting panels with formwork bearers in the form of walers are used for foundation formwork. Individual foundations are also secured by means of walers but of rim type.

Bracing is by squared and round timbers as well as boards diagonally arranged. Tie wires as well as metal screws are used as formwork ties.

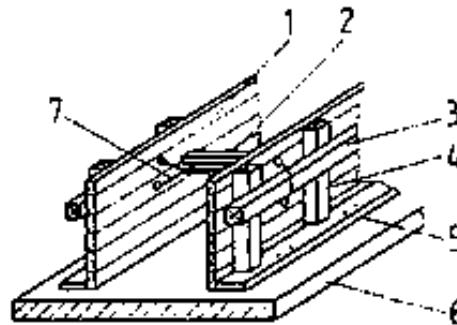

Figure 7 Foundation formwork

1 formwork sheeting, 2 stull, 3 waler, 4 post, 5 thrust-board, 6 concrete bottom, 7 tie wire

How is lifting of a foundation formwork prevented?

4.2. Wall Formwork

Wall formwork consists of vertically arranged upright timbers (formwork bearers) to which sheeting boards are nailed at the concrete side. The upright timbers are diagonally braced by means of boards at both sides.

On cleats situated at every third upright timber, there are horizontally arranged walers. The opposite walers are tied at specified distances.

Prefabricated sheeting panels may also be used instead of sheeting boards.

Cleaning holes are to be provided at the foot of the formwork.

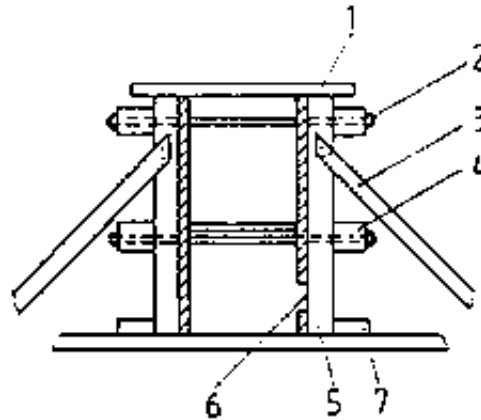

Figure 8 Wall formwork (vertical section)

1 stull, 2 screw tie, 3 bracing, 4 waler 5 post, 6 cleaning hole, 7 thrust-board

4.3. Ceiling Formwork

Ceiling formwork is the type of formwork mostly found in structures/buildings.

The formwork sheeting may consist of sheeting boards or prefabricated sheeting panels. The formwork sheeting may consist of sheeting boards or prefabricated sheeting panels. The formwork sheeting lies on squared timber formwork bearers which are arranged on main bearers carrying off the forces to round timber columns. With smaller rooms, the main bearer together with two columns form a trestle. Diagonal board bracings are provided to take up horizontally acting forces. The round timber columns are placed on double wedges which serve as stripping aid and correction device.

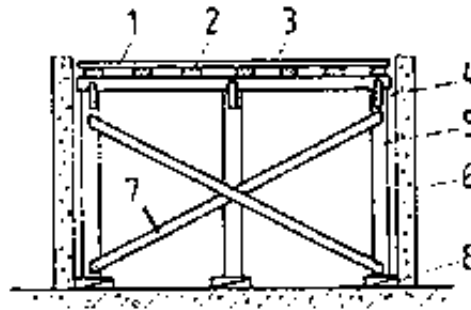

Figure 9 Ceiling formwork (vertical section)

1 formwork sheeting, 2 formwork bearer, 3 main bearer, 4 cleat, 5 column, 6 wall, 7 bracing, 8 support wedges

Which auxiliary means is used to facilitate stripping of the columns?

4.4. Beam Formwork

Beam formwork has prefabricated formwork sheeting parts (sheeting bottom and side sheeting panels). Such individual parts are manufactured based on the beam

dimensions specified in the project. For prefabrication of the formwork sheeting parts, a special preparation table must be manufactured on site.

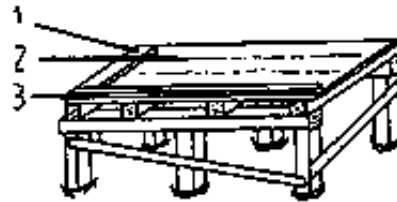

Figure 10 Preparation table

1 square strip, 2 post, 3 stop rail

The sheeting bottom and the side panels consists of sheeting boards nailed together by means of cover straps. Depending on the size of the beam, the width of the sheeting bottom is dimensioned so as to accept, at both sides of the width of the reinforced concrete column, the tickness of the sheeting and cover straps and the width of a thrust-board (approximately 100 mm).

The sheeting bottom can be placed on a pedestal support (a trestle formed by a waler connected with two columns by means of cleats) or on a round timber column also supporting a waler with cleat connection. In the latter case, the round timber column is located under the centre of the beam. By diagonal board bracing the round timber column and the waler above it, a composite triangle is formed. The side sheeting is erected on the sheeting bottom and held by a thrust-board.

At the upper edge of the side sheeting a waler is mounted at both sides holding together the formwork by wire or spindle ties.

A stull-batten is to be nailed on the formwork immediately above the ties to ensure that the projected beam width is kept when tying the formwork.

The waler and the columns are additionally braced by diagonal boards.

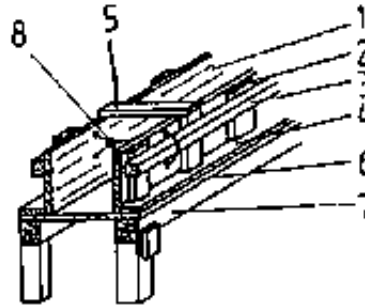

Figure 11 Beam formwork

1 side panel, 2 cover strap, 3 waler, 4 thrust-board, 5 stull, 6 formwork bottom, 7 trestle, 8 tie wire

What is the minimum width a sheeting bottom of beam formwork must have?

4.5. Column Formwork

Similar to beam formworks, the sheeting of column formworks is prefabricated according to the column dimensions from sheeting boards connected by cover straps.

The sheeting panels are placed in a foot rim which is anchored in the soil by steel bolts.

The foot rim consists of double-nailed boards. The foot rim must be exactly measured-in because it is decisive for the exact location of the column. It has the same functions as the thrust-board for foundation or beam formwork.

When the sheeting panels have been inserted in the foot rim, vertical arch timbers are placed to take up the forces from the cover straps of the formwork sheeting.

Around the arch timbers, which have the function of walers, column clamps of flat steel are clamped with wedges or a rim of boards is arranged similar to the foot rim. Additional formwork tying by tie wires or steel screws is not necessary.

The distances of the clamps are specified in the formwork project. Normally they are approximately 700 mm.

The column in the formwork is laterally tied by diagonal board braces.

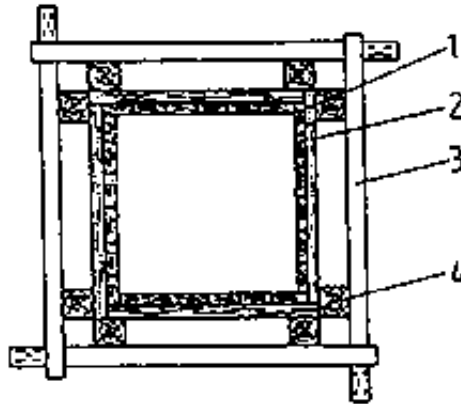

Figure 12 Column formwork (horizontal section)

1 formwork sheeting, 2 cover strap, 3 clamp, 4 arch timber

A lateral cleaning hole is to be provided at the foot of the formwork for removal of any impurities in the form-work before the concrete is placed.

If a steel reinforcement is to be erected in the column formwork, two sides of the column only are to be provided with formwork first to permit easy erection of the reinforcement. After erection of the reinforcement, the remaining two sides of the column formwork can be mounted.

The two sides mounted first are to be arranged cornerwise to ensure provisional stability.

How can impurities in the column formwork be removed?



[Home](#) > [ar.cn.de.en.es.fr.id.it.ph.po.ru.sw](#)

 **Formwork Making - Course: Timberwork techniques. Trainees' handbook of lessons (Institut fr Berufliche Entwicklung, 14 p.)**

 ***(introduction...)***

 **1. Purpose and Use of Formwork**

 **2. Functional and Load Requirements of Formwork**

 **3. General Construction of Formwork**

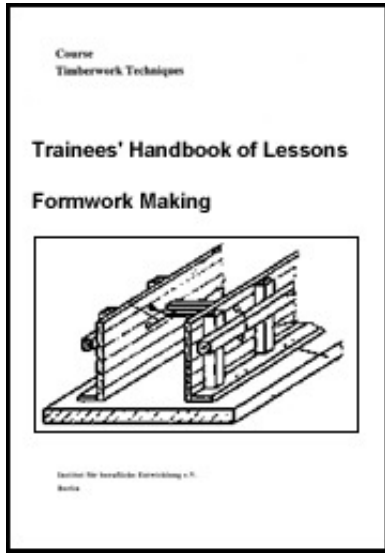

4: Types of Formwork

5: Preparation and Aftertreatment of Formwork

5. Preparation and Aftertreatment of Formwork

Before placing the concrete, the formwork is to be cleaned and checked again for proper execution.

After cleaning, the cleaning holes of wall and column formworks are to be tightly closed since the maximum pressure of the concrete mix is occurring at the foot of the formwork where the cleaning holes are situated. For this purpose, the sheeting pieces of the cleaning holes are always to be put against the thrust-board and against formwork bearers. If necessary, additional formwork bearers are to be mounted. Immediately before concreting, the formwork is to be thoroughly wetted with water because thereby less water will be extracted from the concrete mix and later stripping will be facilitated. When placing the concrete, it is to be made sure that no changes take place with the formwork.

Stripping of the formwork must not be started unless the site engineer in charge

has given the respective express instructions. Too early removal of the formwork parts may cause heavy damage to the structure and/or injury of persons.

Stripping is to be done very carefully. Neither the concrete nor the formwork timbers must be damaged. Emergency columns are the last to be removed. When stripping, greatest attention is to be attached to the structural direction of forces of the formwork. All nails are to be removed from the stripped formwork timbers, and the stripped timbers are to be cleaned and overly stacked. The strict observance of labour safety regulations is of special importance for stripping work because of the danger of falling-down formwork parts.

