

[Home](#) > [ar.cn.de.en.es.fr.id.it.ph.po.ru.sw](#)

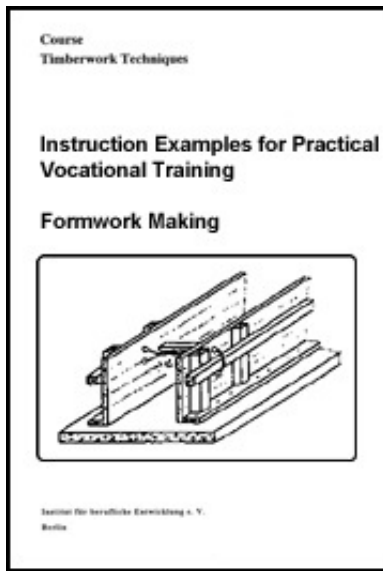





- ➔ **Formwork Making - Course: Timberwork techniques. Instruction examples for practical vocational training (Institut für Berufliche Entwicklung, 23 p.)**
 - 📄 **(introduction...)**
 - 📄 **Preliminary Remarks**
 - 📄 **Instruction Example 1.1. Prefabrication of Formwork Panels**
 - 📄 **Instruction Example 1.2. Ceiling Formwork Making**
 - 📄 **Instruction Example 1.3. Strip Foundation Formwork Making**
 - 📄 **Instruction Example 1.4. Beam Formwork Making**
 - 📄 **Instruction Example 1.5. Column Formwork Making**

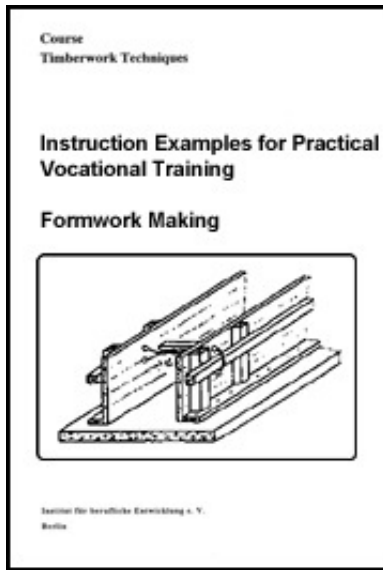

[Home](#) > [ar.cn.de.en.es.fr.id.it.ph.po.ru.sw](#)

- 📖 **Formwork Making - Course: Timberwork techniques. Instruction examples for practical vocational training (Institut für Berufliche Entwicklung, 23 p.)**
 - ➔ 📄 **(introduction...)**
 - 📄 **Preliminary Remarks**
 - 📄 **Instruction Example 1.1. Prefabrication of Formwork Panels**



-  **Instruction Example 1.2. Ceiling Formwork Making**
-  **Instruction Example 1.3. Strip Foundation Formwork Making**
-  **Instruction Example 1.4. Beam Formwork Making**
-  **Instruction Example 1.5. Column Formwork Making**

**Institut für berufliche Entwicklung e. V.
Berlin**

Original title:

**Lehrbeispiele für die berufspraktische Ausbildung
"Herstellen von Schalungen"**

Author: Peter Wehrmann

First edition © IBE

**Institut für berufliche Entwicklung e.V.
Parkstraße 23
13187 Berlin**

Order No.: 93-33-3601/2



[Home](#) > [ar](#).[cn](#).[de](#).[en](#).[es](#).[fr](#).[id](#).[it](#).[ph](#).[po](#).[ru](#).[sw](#)

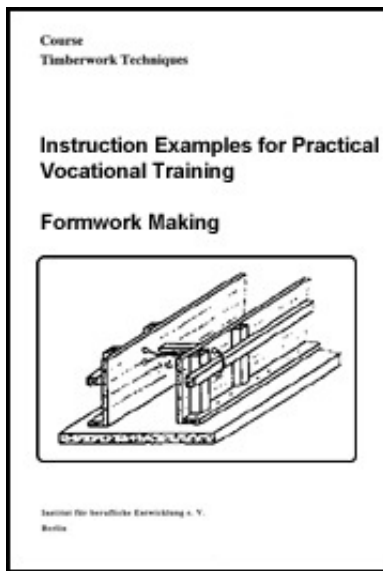

Formwork Making - Course: Timberwork techniques. Instruction examples for practical vocational training (Institut für Berufliche Entwicklung, 23 p.)

 **(*introduction...*)**

  **Preliminary Remarks**

 **Instruction Example 1.1. Prefabrication of Formwork Panels**

 **Instruction Example 1.2. Ceiling Formwork Making**

 **Instruction Example 1.3. Strip Foundation Formwork Making**

 **Instruction Example 1.4. Beam Formwork Making**

 **Instruction Example 1.5. Column Formwork Making**

Preliminary Remarks

The present booklet contains 5 selected instruction examples to practise making of different types of form-work.

The first example serves for practising the prefabrication of formwork panels.

Prefabricated formwork panels are indispensable for beam and column formworks. Prefabricated formwork panels, however, are also recommended for series production of foundation and ceiling formworks.

In that case the construction of the panels differs from that of panels for beam and column formworks but the technology of prefabrication is the same.

The construction of a multi-use formwork panel for beam and column formwork is explained and shown in the Trainees' Handbook of Lessons.

Thus example 1.1. represents direct or possible preparations for the other four examples and, therefore, there is a close technological connexion between them. The examples 1.2. to 1.5. explain how to produce the four most common types of formwork.

The required materials, tools and auxiliary accessories are specified for each example.

Moreover, the necessary previous knowledge is stated which is the basis for independent practising by the trainee.







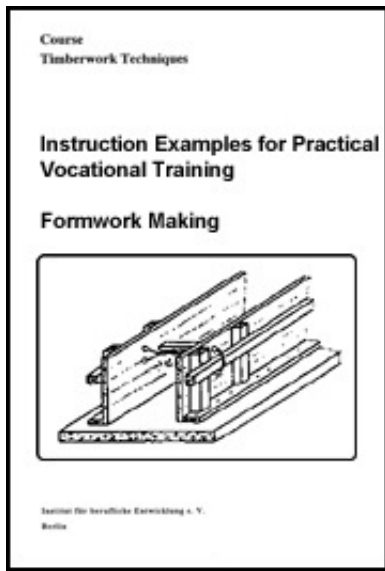

The order of working steps of the relevant sequence of operations for the individual examples has been established by experience. If it is strictly followed, no faults would normally occur.

The examples selected can be modified to suit the relevant site conditions. Specific modifications ordered, however, may require changes to the sequence of operations.



[Home](#) > [ar](#).[cn](#).[de](#).[en](#).[es](#).[fr](#).[id](#).[it](#).[ph](#).[po](#).[ru](#).[sw](#)



-  **Formwork Making - Course: Timberwork techniques. Instruction examples for practical vocational training (Institut für Berufliche Entwicklung, 23 p.)**
-  **(introduction...)**
-  **Preliminary Remarks**
-  **Instruction Example 1.1. Prefabrication of Formwork Panels**
-  **Instruction Example 1.2. Ceiling Formwork Making**
-  **Instruction Example 1.3. Strip Foundation Formwork Making**
-  **Instruction Example 1.4. Beam Formwork Making**
-  **Instruction Example 1.5. Column Formwork Making**

Instruction Example 1.1. Prefabrication of Formwork Panels

This example serves for practising the prefabrication of formwork panels for beam and column formworks, in particular the prefabrication of a bottom panel for beam formwork.

Material

**Formwork boards - 25 mm thick
nails - 40 mm and 70 mm long**

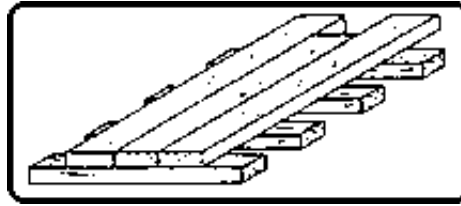

Figure

Hand tools and machines

Circular saw, hand saw, hammer, wrecking bar with claw

Measuring and testing means

Folding rule, try square, measuring rods

Auxiliary accessories

Pencil, paper

Necessary previous knowledge

Handling of length measuring tools, scribing, working with the circular saw and manual sawing

Explanations to the working drawing

1 formwork bottom, 2 cover strap projection, 3 sheeting thickness, 4 cover strap

thickness 25 mm, 5 thrust-board width 100 mm

Sequence of operations

1. Prepare the work.
2. Enter all sizes required into the working drawing.
3. Cut up the boards.
4. Cut the stiffening cover straps to length.
5. Put the cover straps on the arranged boards according to the size distribution made.
6. Nail the cover straps on the board-panel.
7. Nail the cover straps on the boards from the opposite side.
8. Clinch the nail tips.

Comments

- Make available the tools and materials. A work table is to be manufactured (See Fig. 10 in the Trainees' Handbook).
- Derive the sizes from the dimensions of the beam for which the formwork is to be made. Prepare the size distribution of the cover straps in particular.
- The board width should not exceeded 140 mm. Do not place the rough edge of the board to the inside of the formwork!
- Cover straps to have a width of approx. 55 mm with 25 mm projection for comer joints!
- Use measuring rod, if necessary!
- It is provisional nailing with short nails (40 mm). Use as many nails as necessary to make the panel stable in itself.
- Turn over the provisionally nailed board-panel and nail it with 70 mm long nails. Two nails per board are to be diagonally arranged at the cover strap joint!
- Turn over the panel again and clinch the penetrated nail tips!

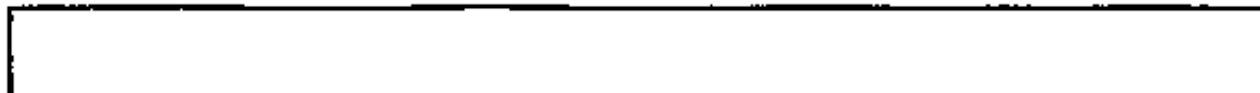

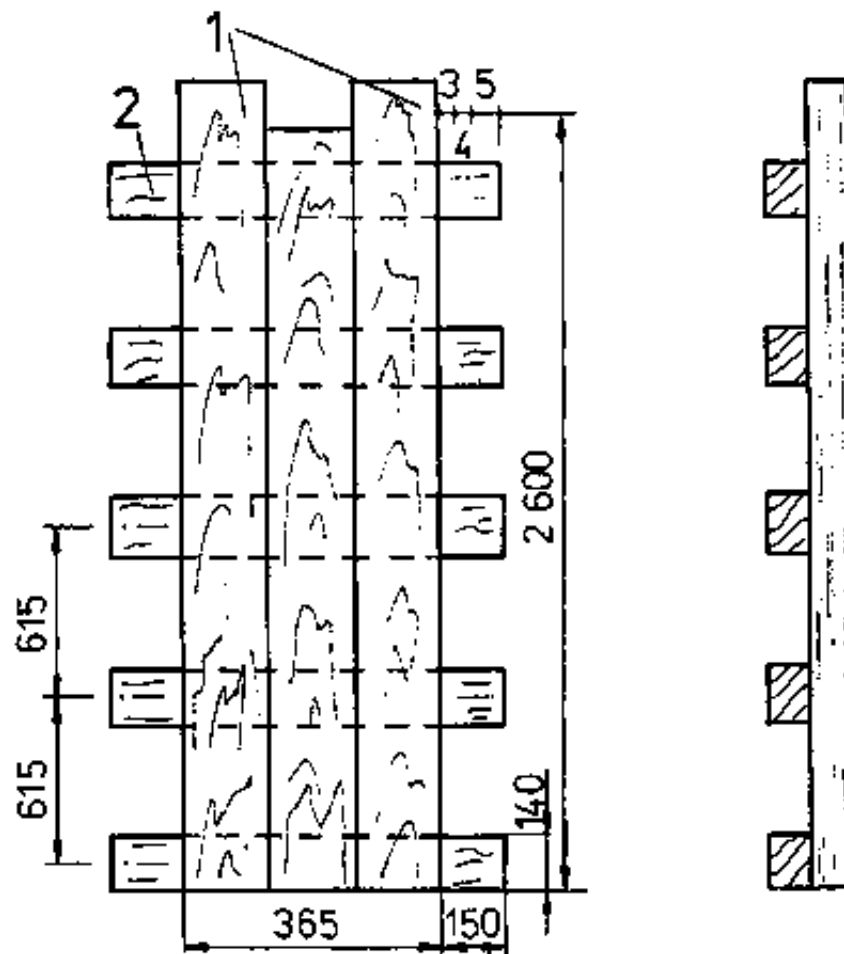
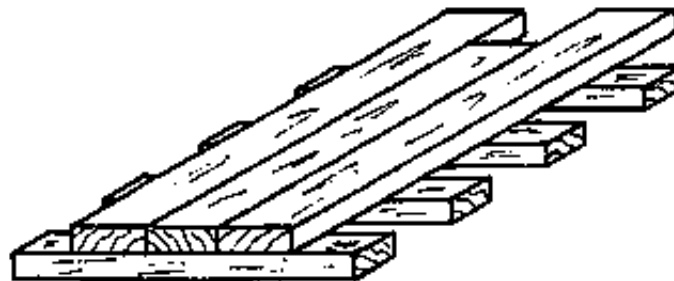

				1.1.
IBE	Prefabrication of Formwork Panels			3601

Prefabrication of Formwork Panels



[Home](#) > [ar](#).[cn](#).[de](#).[en](#).[es](#).[fr](#).[id](#).[it](#).[ph](#).[po](#).[ru](#).[sw](#)

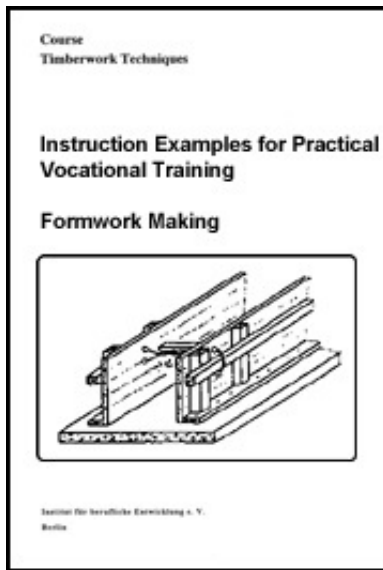

- Formwork Making - Course: Timberwork techniques. Instruction examples for practical vocational training (Institut für Berufliche Entwicklung, 23 p.)**
- (introduction...)**
- Preliminary Remarks**
- Instruction Example 1.1. Prefabrication of Formwork Panels**
- Instruction Example 1.2. Ceiling Formwork Making**
- Instruction Example 1.3. Strip Foundation Formwork Making**
- Instruction Example 1.4. Beam Formwork Making**
- Instruction Example 1.5. Column Formwork Making**

Instruction Example 1.2. Ceiling Formwork Making

This example serves to practise making of a ceiling formwork in a room of given dimensions.

Material

**Formwork boards 25 mm thick
squared timbers 120 mm x 100 mm
round timbers of 150 mm diameter
various wooden wedges
nails of different sizes**

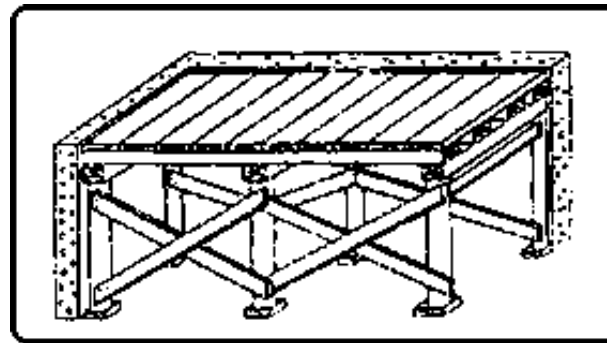

Figure

Hand tools and machines

Circular saw, hand saw, hammer, wrecking bar with claw, nail pincers

Measuring and testing means

Folding rule, try square, water level, measuring rod

Auxiliary accessories

Paper, pencil

Necessary previous knowledge

Manual sawing, working with the circular saw, measuring , scribing, nailing, sketching

Explanations to the working drawing

1 walling, 2 trestle timber, 3 formwork bearer, 4 sheeting boards, 5 diagonal (cross) bracing

Sequence of operations Comments

- | | |
|---|--|
| 1. Study the formwork project and/or prepare a formwork sketch. | Dimensions in the instruction example are guidelines only! |
| 2. Make available the required tools and materials. | Use sharpened sawing tools only! |
| 3. Determine the column height and cut up the column. | Six columns are to be produced; the height depends on the height of the room (see Trainees' Handbook)! Cleats for fixing are to be provided at the sides of the columns! |
| 4. Cut the trestle timbers to length. | For an assumed narrow side of the room of 3.5 m three trestle timbers are to be produced! |
| 5. Fix the trestle timbers, | Fix the trestle timbers through the cleats to the columns. Lean |

cut up and nail diagonal bracing and erect the trestle.

6. Secure the trestles provisionally.

7. Level the trestles.

8. Fix the formwork bearers on the trestles.

9. Nail on the sheeting boards.

10. Check the formwork for accuracy to size and for strength.

the right and left trestles and one side of the centre trestle against the wall! The trestles are to be put to the floor for nailing.

Erect the trestles and drive wedges between the wall and end face of the trestle timbers. 3 persons are required for this work!

Use water level and levelling board for levelling. Adjust the height of the columns by means of packing wedges. Columns must be exactly perpendicular.

Cut formwork bearers to length and put them on the trestles at certain intervals (60 to 70 cm). Ensure parallelism! Use nail pins for fixing.

Cut sheeting boards to length and nail them onto formwork bearers. In view of later stripping, do not use nails which are longer than 50 mm!

Make corrections in case of deviations. For bigger rooms place more columns under the trestles.

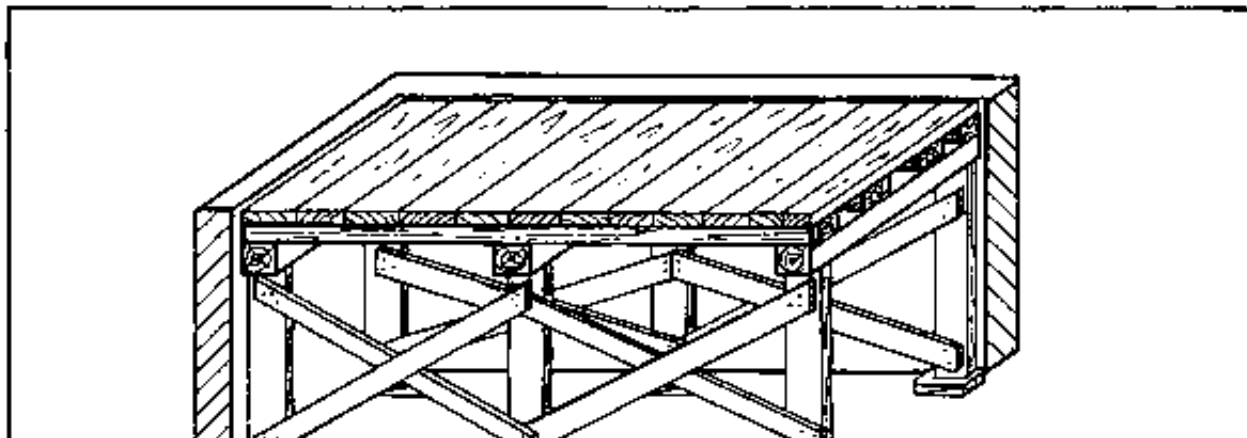

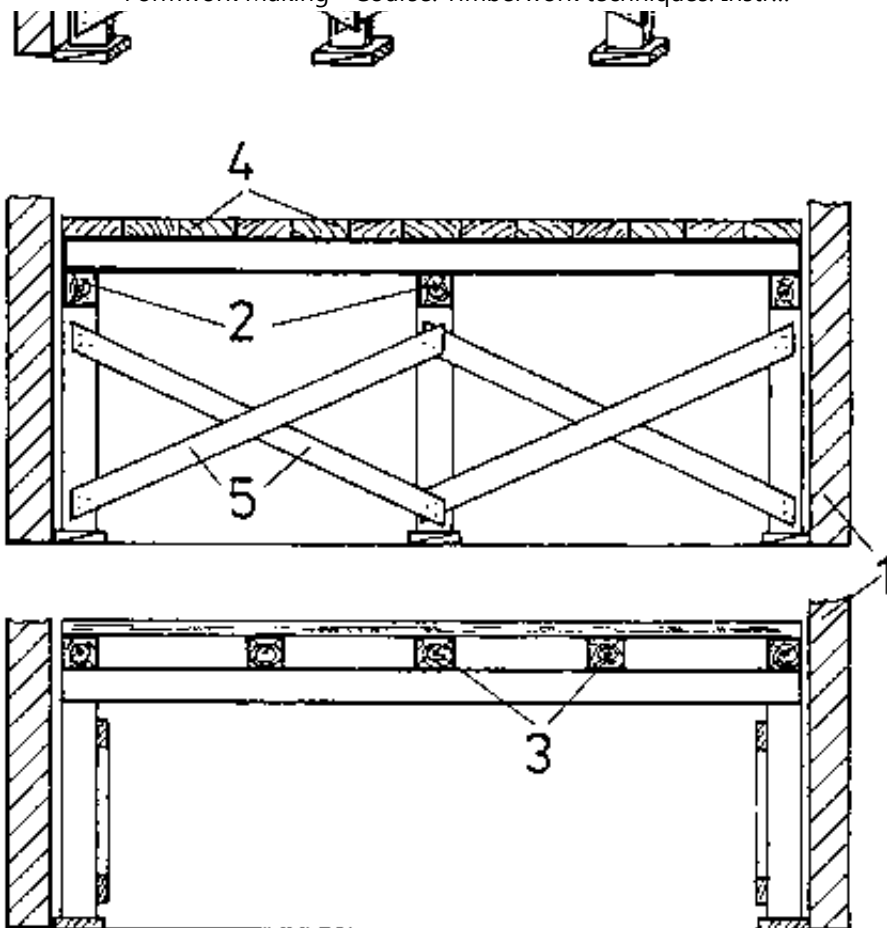







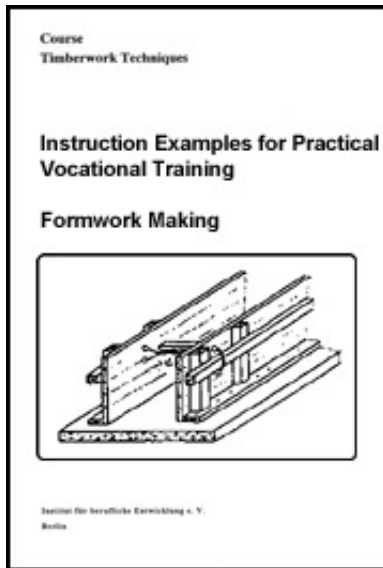

				1.2.
IBE	Ceiling Formwork Making			3601

Ceiling Formwork Making



[Home](#) > [ar](#).[cn](#).[de](#).[en](#).[es](#).[fr](#).[id](#).[it](#).[ph](#).[po](#).[ru](#).[sw](#)



-  **Formwork Making - Course: Timberwork techniques. Instruction examples for practical vocational training (Institut für Berufliche Entwicklung, 23 p.)**
-  **(introduction...)**
-  **Preliminary Remarks**
-  **Instruction Example 1.1. Prefabrication of Formwork Panels**
-  **Instruction Example 1.2. Ceiling Formwork Making**
-  **Instruction Example 1.3. Strip Foundation Formwork Making**
-  **Instruction Example 1.4. Beam Formwork Making**
-  **Instruction Example 1.5. Column Formwork Making**

Instruction Example 1.3. Strip Foundation Formwork Making

This example serves to practise making of a strip foundation formwork to given dimensions of a drawing (without lateral border).

Material

Formwork boards
square timbers
nails of different sizes
tie wire
steel nails

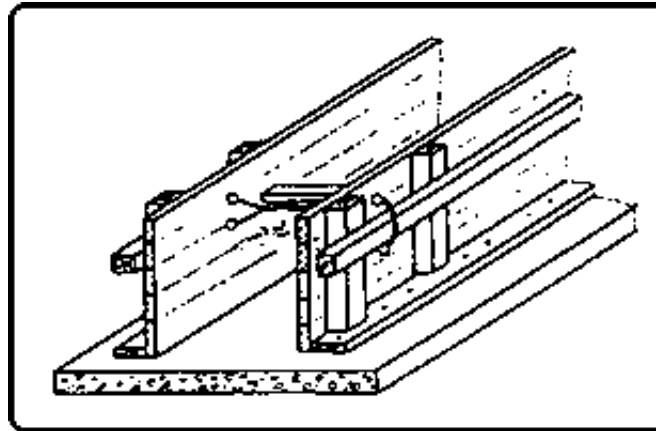

Figure

Hand tools and machines

Circular saw, hand saw, hammer, wrecking bar with claw, nail pincers, bit, bit brace

Measuring and testing means

Folding rule, try square, water level, measuring rods

Auxiliary accessories

Paper, pencil, line

Necessary previous knowledge

Handling of length measuring tools, scribing, manual sawing and working with the circular saw

Explanations to the working drawing

1 stull, 2 formwork sheeting, 3 post, 4 waler, 5 width of foundation, 6 steel rod for tying of the tie wire, 7 tie wire

Sequence of operations

1. Study the formwork project.
2. Stretch the alignment lines.
3. Nail a formwork bottom board onto the foundation.
4. Erect the vertical post timbers
 - Distances between the post timbers: 600 mm
 - Length of the post timbers depending on the foundation height.
5. Fixing of the sheeting boards to the post

Comments

Under the strip foundation to be erected there must be a horizontal layer of concrete (approx. 100 mm)!

The upper edges of the foundation determine the points of alignment of the lines. Use line supports or other measuring point aids!

Nail on the formwork bottom board with steel nails exactly in alignment.

After erection of the post timbers fix them with nail pins. On top the post timbers are to be stabilize by stulls to be nailed on!

Start nailing from the bottom!

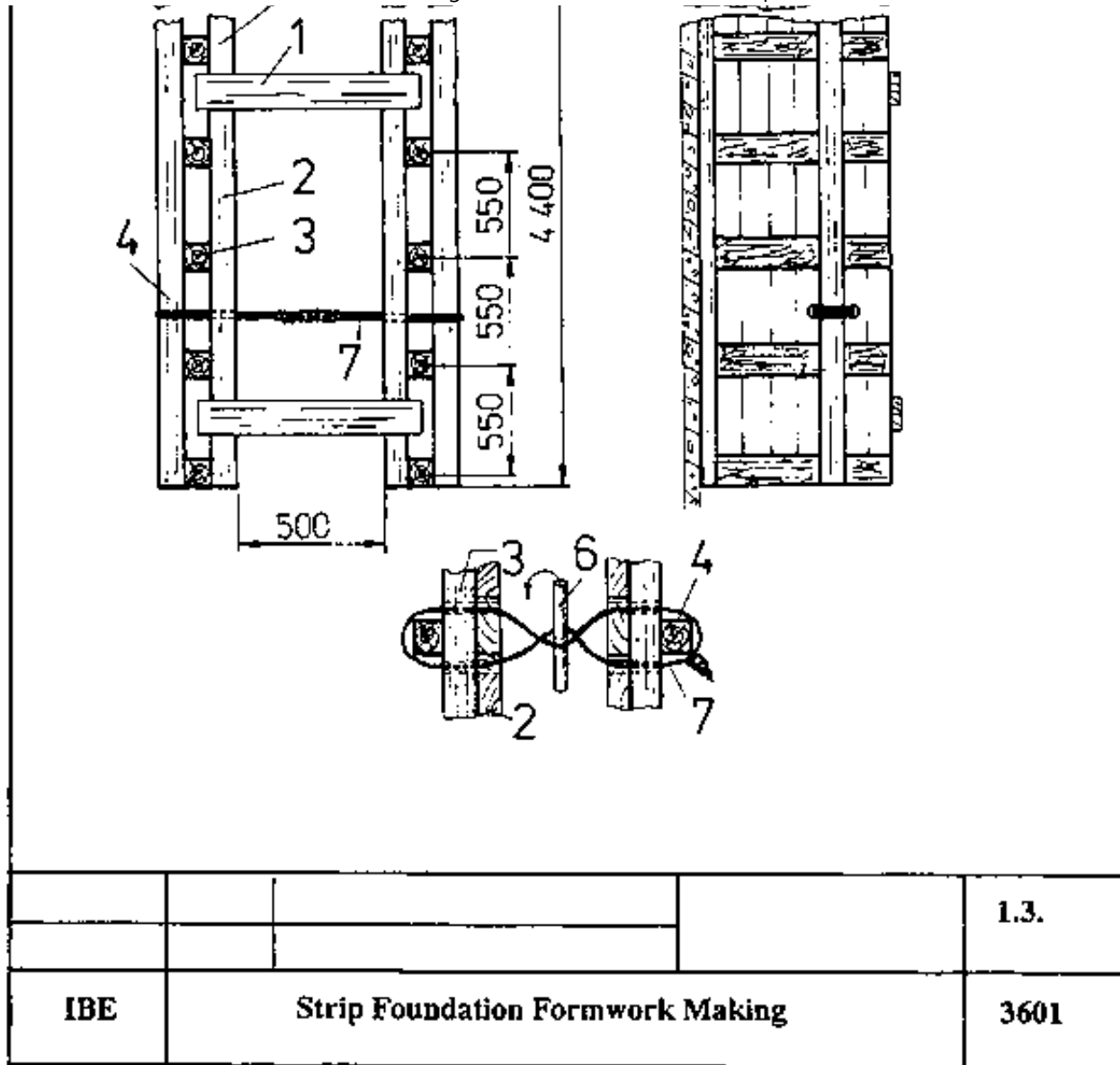

Strip Foundation Formwork Making



[Home](#) > [ar.cn.de.en.es.fr.id.it.ph.po.ru.sw](#)

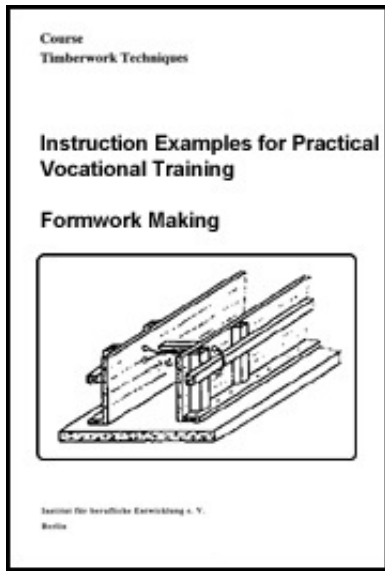

Formwork Making - Course: Timberwork techniques. Instruction examples for practical vocational training (Institut für Berufliche Entwicklung, 23 p.)

 **(introduction...)**

 **Preliminary Remarks**

 **Instruction Example 1.1. Prefabrication of Formwork Panels**

 **Instruction Example 1.2. Ceiling Formwork Making**

 **Instruction Example 1.3. Strip Foundation Formwork Making**

 **➔ Instruction Example 1.4. Beam Formwork Making**

 **Instruction Example 1.5. Column Formwork Making**

Instruction Example 1.4. Beam Formwork Making

This example serves to practise making of a beam formwork for a brickwork wall coping to given sizes.

Material

**Formwork boards
squared timbers
nails of different sizes
tie wire**

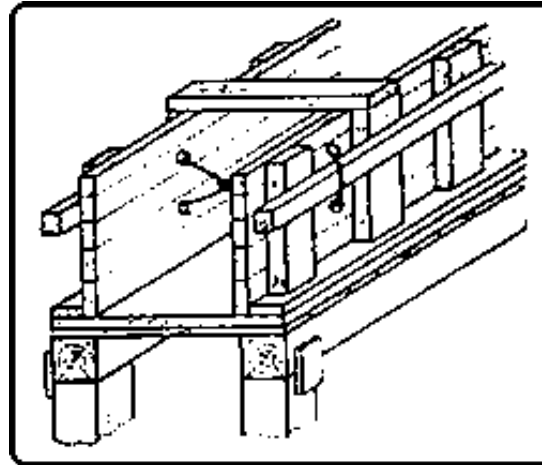

Figure

Hand tools and machines

Circular saw, hand saw, hammer, wrecking bar with claw, nail pincers, bit, bit brace

Measuring and testing means

Folding rule, try square, water level, measuring rods

Auxiliary accessories

Paper, pencil

Necessary previous knowledge

See ceiling formwork

Explanations to the working drawing

1 brickwork, 2 brickwork support, 3 stull, 4 formwork side panel, 5 cover straps, 6 waler, 7 formwork bottom panel

Sequence of operations

1. Study the formwork project.
Prepare the work.

2. Make two trestles (columns connected with trestle timber through cleats) for the longitudinal front of the wall.

3. Erect the trestles and secure them laterally by wedges.

4. Nail on two board-connectors at the left and right of the beam wall support.

5. Fix the diagonal bracings to the columns.

6. Make the formwork bottom (See instruction example 1.1.):

7. Put the prefabricated side panels on the cover strap projection at the left and right sides and connect them with

Comments

Make available the tools and materials.

Dimension the height of the columns so as to allow for two packing wedges, the formwork sheeting (sheeting boards)!

Trestles to stand exactly at the outside wall lines!

The 200 mm distance to the wall must correspond with the cover strap dimensions. Upper edge of formwork sheeting is equal to lower edge of beam!

Nail bracings longitudinally and transversely to the wall!

Do not cut the cover straps flush but make allowance at both sides at least for formwork sheeting thickness, cover strap thickness and thrust-board width!

According to the brickwork support openings of the beam, the length of the side panels is to be dimensioned so as to permit that the supports are

stulls on the upper edges.

enclosed by the formwork at both sides!

8. Nail on a thrust-board at the lateral foot of the formwork panels.

Nail on from both sides!

9. Fix walers at the sides of formwork panels (upper end).

Fix walers laterally with nail pins!

10. Tie the formwork with tie wire at the walers.

The walers must also cover the brickwork support openings. The tie-wire tying is to be provided immediately near the stulls!

11. Check the formwork again for alignment and accuracy to size.

Make corrections, if necessary.

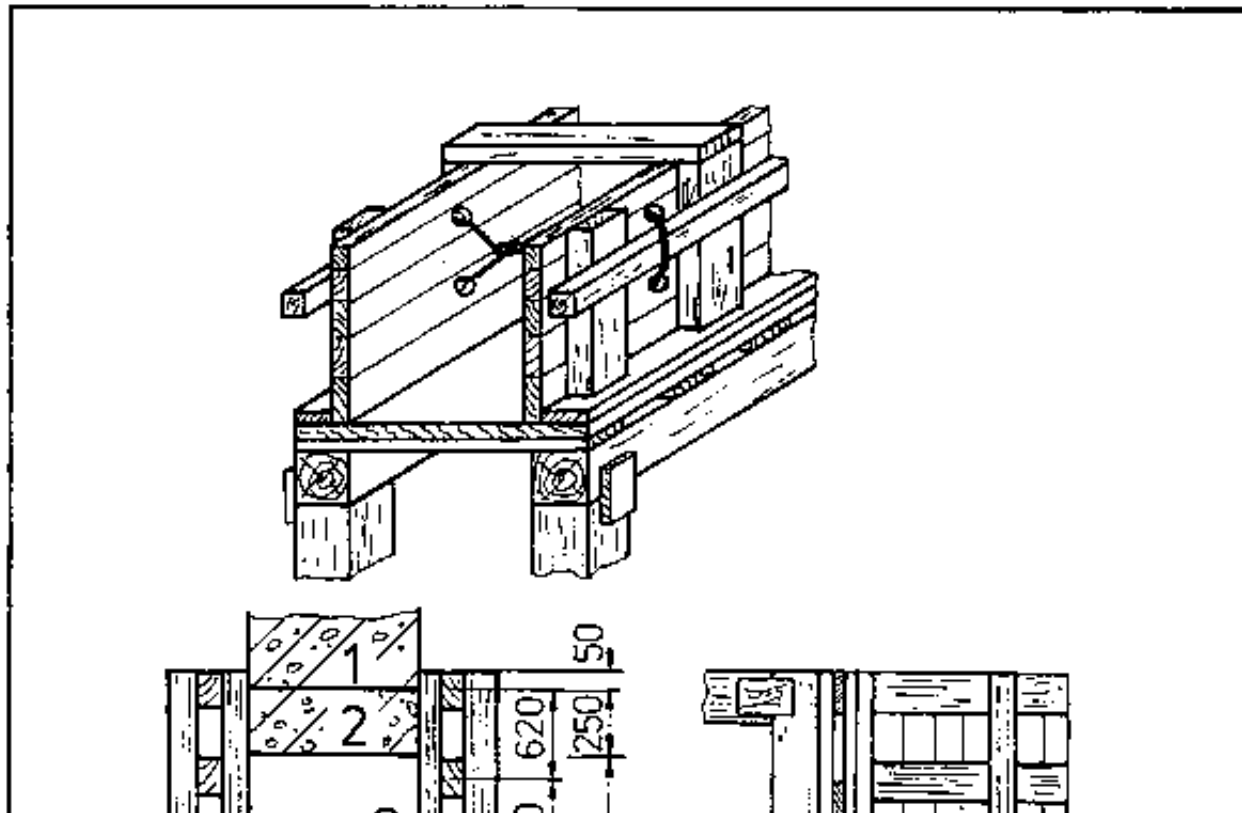

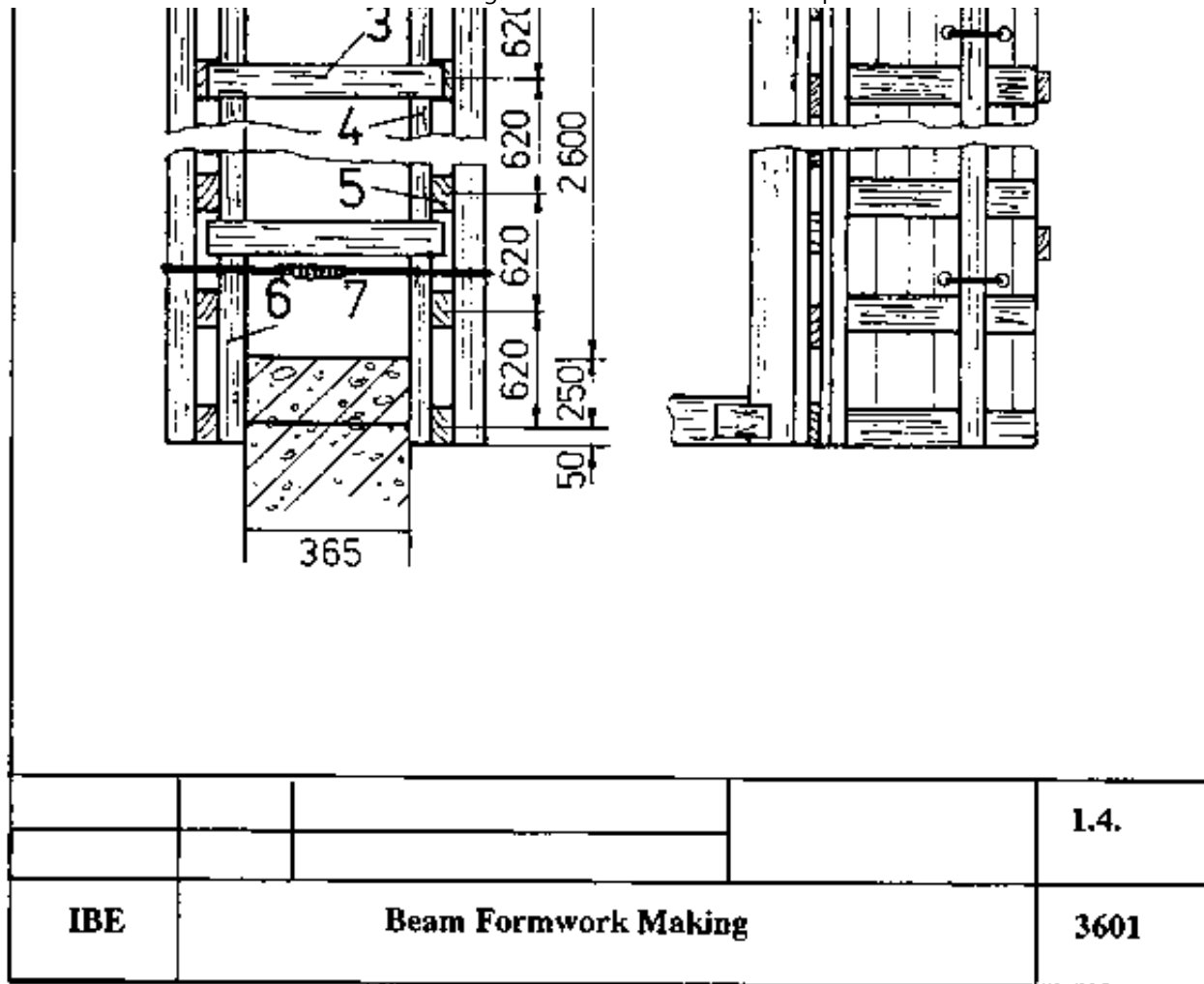

Beam Formwork Making



[Home](#) > [ar](#) [.cn](#) [.de](#) [.en](#) [.es](#) [.fr](#) [.id](#) [.it](#) [.ph](#) [.po](#) [.ru](#) [.sw](#)

 **Formwork Making - Course: Timberwork techniques. Instruction examples for practical vocational training**

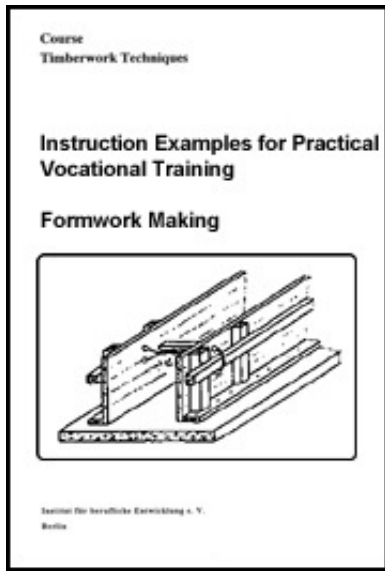

(Institut für Berufliche Entwicklung, 23 p.)

 **(introduction...)**

 **Preliminary Remarks**

 **Instruction Example 1.1. Prefabrication of Formwork Panels**

 **Instruction Example 1.2. Ceiling Formwork Making**

 **Instruction Example 1.3. Strip Foundation Formwork Making**

 **Instruction Example 1.4. Beam Formwork Making**

 **➔ Instruction Example 1.5. Column Formwork Making**

Instruction Example 1.5. Column Formwork Making

This example serves to practise making of a column formwork to given sizes.

Material

**Formwork boards
squared timbers
nails of different sizes**

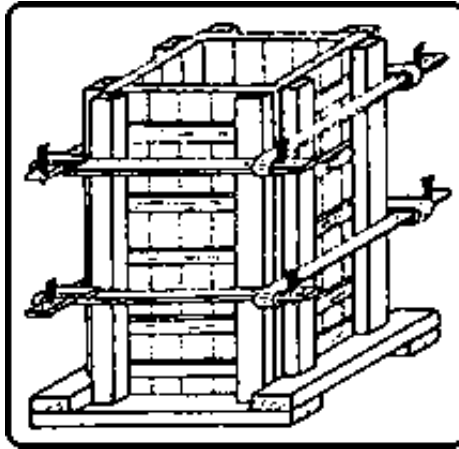

Figure

Hand tools and machines

Circular saw, hand saw, hammer wrecking bar with claw, nail pincers, column clamps of steel with steel wedges

Measuring and testing means

Folding rule, try square, water level, plump

Auxiliary accessories

Paper, pencil

Necessary previous knowledge

See ceiling form work

Explanations to the working drawing

1 arch timber, 2 formwork sheeting, 3 steel clamps, 4 steel wedge, 5 cover straps of formwork sheeting panel, 6 foot rim, 7 nailing, 8 steel nails

Sequence of operations

Comments

- | | |
|--|--|
| 1. Study the formwork project. | Make available the tools and materials. |
| 2. Scribe the size of the column on the concrete bottom. | If steel reinforcements project from the concrete bottom, they are to be connected with the column reinforcement! |
| 3. Nail the column rim on the concrete. | The inside dimensions of the column rim must allow for 25 mm sheeting thickness per side. The column rim is to be prefabricated from boards! |
| 4. Erect one column comer. | Alternately insert two prefabricated panels in the column rim to form a comer and nail them together. If necessary, support them diagonally by boards! |
| 5. Place the reinforcing steel. | |
| 6. Erect the second column comer. | Insert the remaining two panels in the column rim and nail them alternately! One panel must have a cleaning hole at the foot! |
| 7. Erect the arch timbers. | Erect and fix with nails two arch timbers (100 mm x 100 mm) at both sides of each corner! Make sure that the column formwork is perpendicular! |
| 8. Tie the column | Wrap column clamps of flat steel around the arch timbers and tighten |

8. Fit the column wrap column clamps or flat steel around the arch timbers and tighten them with steel wedges. The vertical distance between the column clamps should be approximately 700 mm. If no steel clamps are available, use wooden rims!

9. Check the alignment and accuracy to size.

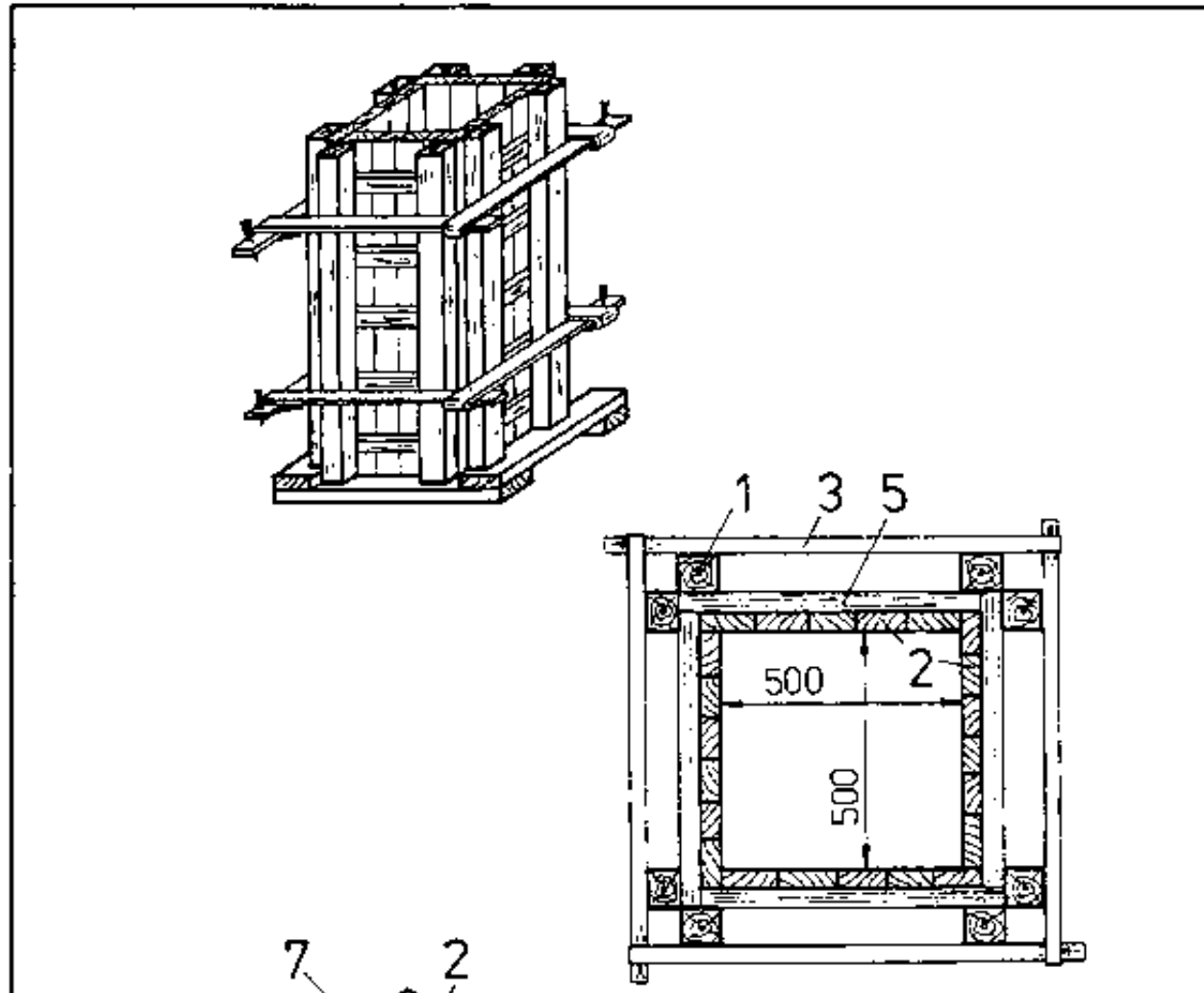

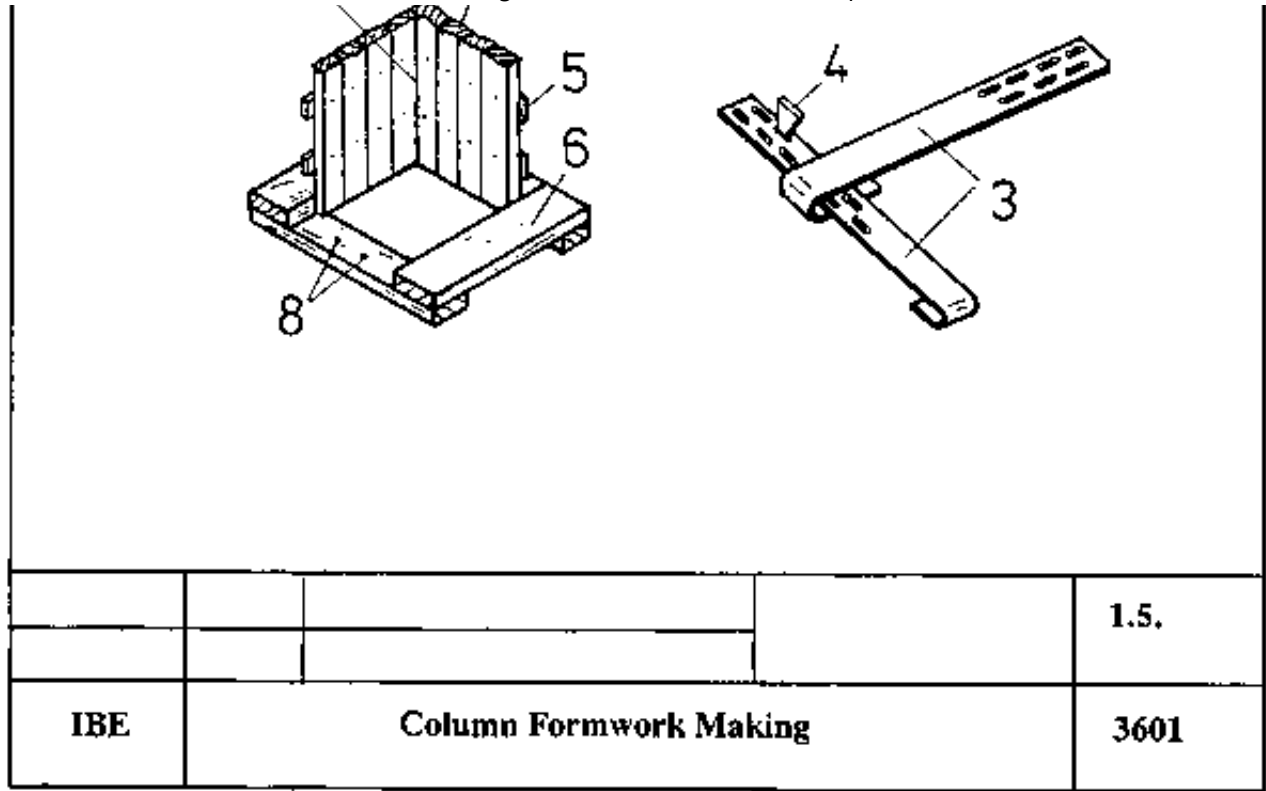

Column Formwork Making

