

[Home](#) > [ar.cn.de.en.es.fr.id.it.ph.po.ru.sw](#)

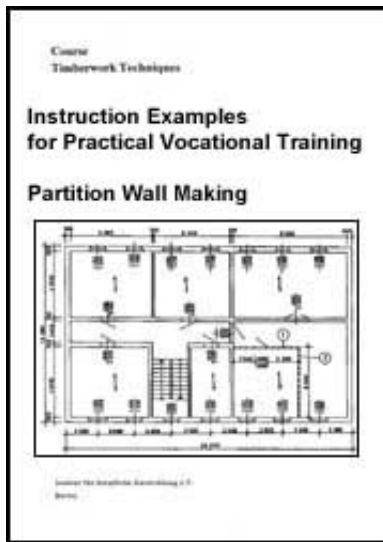







- ➔ **Partition Wall Making - Course: Timberwork techniques. Instruction examples for practical vocational training (Institut fr Berufliche Entwicklung, 35 p.)**
 - 📄 **(introduction...)**
 - 📄 **Preliminary Remarks**
 - 📄 **Instruction Example 5.1.: Calculation of the Pitch Size**
 - 📄 **Instruction Example 5.2.: Scribing of the Runners**
 - 📄 **Instruction Example 5.3.: Scribing of the Posts**
 - 📄 **Instruction Example 5.4.: Scribing of the Stiffening Transoms**
 - 📄 **Instruction Example 5.5.: Scribing of the Door Framework**
 - 📄 **Instruction Example 5.6.: Assembly and Erection of the Partition Wall**

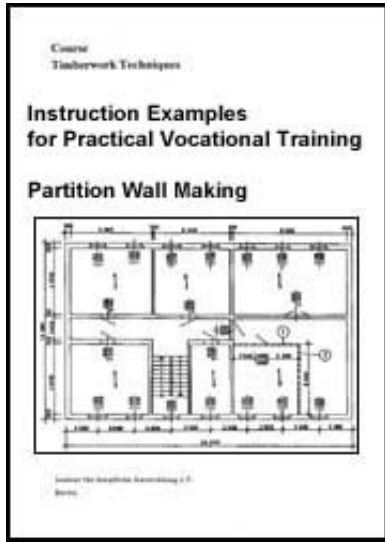

[Home](#) > [ar.cn.de.en.es.fr.id.it.ph.po.ru.sw](#)

- 📖 **Partition Wall Making - Course: Timberwork techniques. Instruction examples for practical vocational training (Institut fr Berufliche Entwicklung, 35 p.)**
 - ➔ 📄 **(introduction...)**
 - 📄 **Preliminary Remarks**



-  **Instruction Example 5.1.: Calculation of the Pitch Size**
-  **Instruction Example 5.2.: Scribing of the Runners**
-  **Instruction Example 5.3.: Scribing of the Posts**
-  **Instruction Example 5.4.: Scribing of the Stiffening Transoms**
-  **Instruction Example 5.5.: Scribing of the Door Framework**
-  **Instruction Example 5.6.: Assembly and Erection of the Partition Wall**

**Institut für berufliche Entwicklung e.V.
Berlin**

**Original title:
Lehrbeispiele für die berufspraktische Ausbildung
"Herstellen von Zwischenwänden"**

Author: Rolf Becher

First Edition © IBE









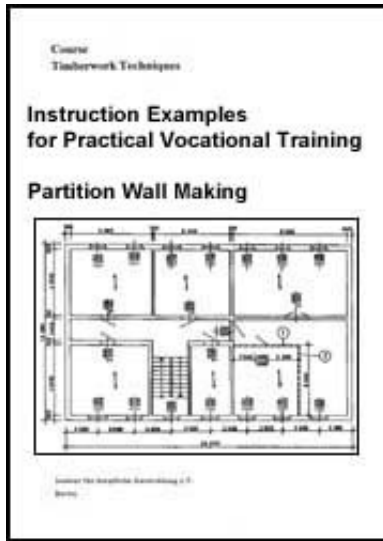

**Institut für berufliche Entwicklung e.V.
Parkstraße 21/23
13187 Berlin**

Order No.: 93-33-3605/2



[Home](#) > [ar](#).[cn](#).[de](#).[en](#).[es](#).[fr](#).[id](#).[it](#).[ph](#).[po](#).[ru](#).[sw](#)



-  **Partition Wall Making - Course: Timberwork techniques. Instruction examples for practical vocational training (Institut fr Berufliche Entwicklung, 35 p.)**
-  **(introduction...)**
-   **Preliminary Remarks**
-  **Instruction Example 5.1.: Calculation of the Pitch Size**
-  **Instruction Example 5.2.: Scribing of the Runners**
-  **Instruction Example 5.3.: Scribing of the Posts**
-  **Instruction Example 5.4.: Scribing of the Stiffening Transoms**
-  **Instruction Example 5.5.: Scribing of the Door Framework**
-  **Instruction Example 5.6.: Assembly and Erection of the Partition Wall**

Preliminary Remarks

The present booklet contains 6 selected instruction examples. They have been selected so that the individual exercises can be practised separately or successively, one based on the previous one.

They all refer to the partition wall to be made which is shown in the detailed drawing on page 5 in the scale of 1: 100. The sizes in the detailed drawing have been freely selected to provide feasible sequences of operations in the instruction examples.

The room limitation in the detailed drawing indicates that a corner post will be required for the partition wall to be made and that the new room has to be made accessible.

The partition wall is to be built between wooden beam ceilings with wall (1) at right angles and wall (2) parallel to the straining direction of the wooden beams.

The instruction examples include the sequence of operations and necessary comments. For instruction examples 2. to 5., working drawings are attached. The individual instruction examples also include information as to the required hand tools, measuring and testing means, auxiliary accessories and the necessary previous knowledge.

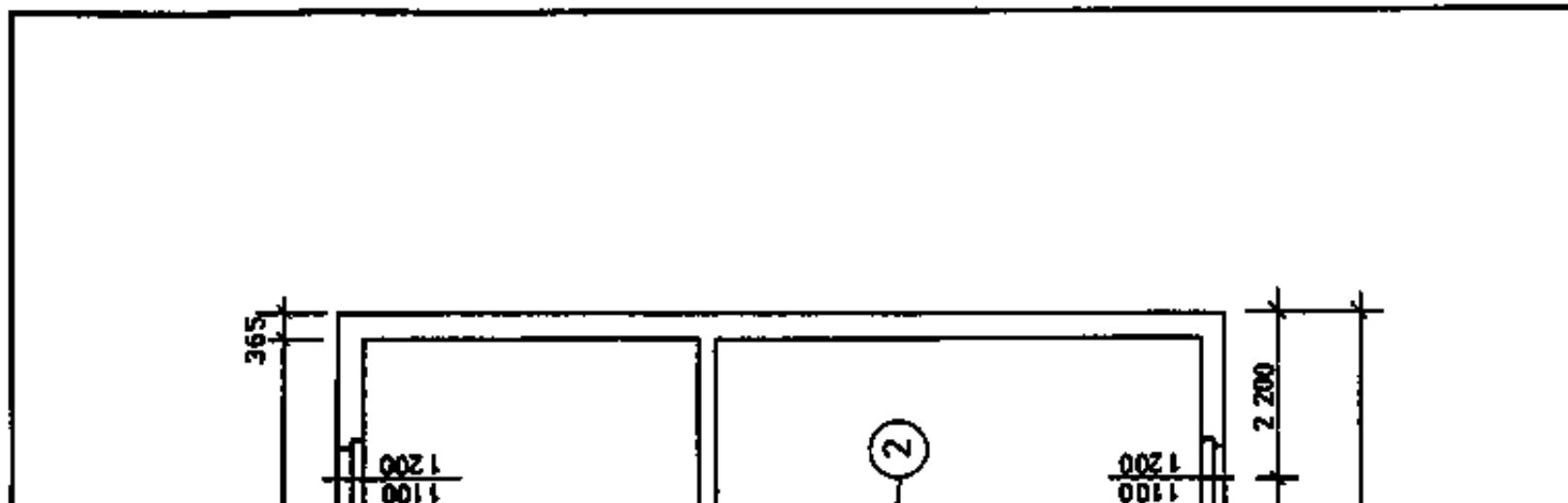

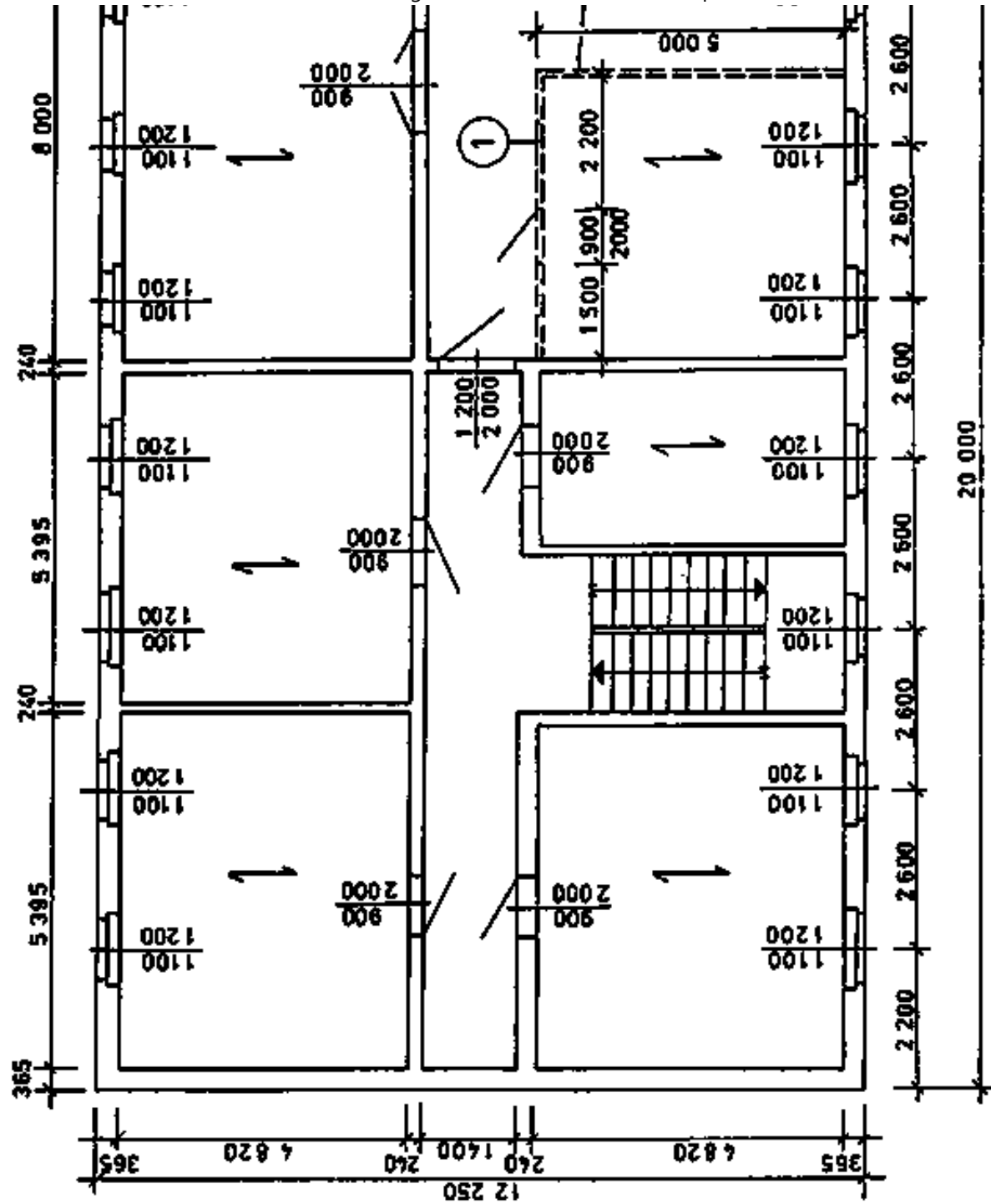

IBE	Layout of the building with partition wall to be made (scale 1 : 100)			3605

Layout of the building with partition wall to be made (scale 1:100)



[Home](#) > [ar](#).[cn](#).[de](#).[en](#).[es](#).[fr](#).[id](#).[it](#).[ph](#).[po](#).[ru](#).[sw](#)

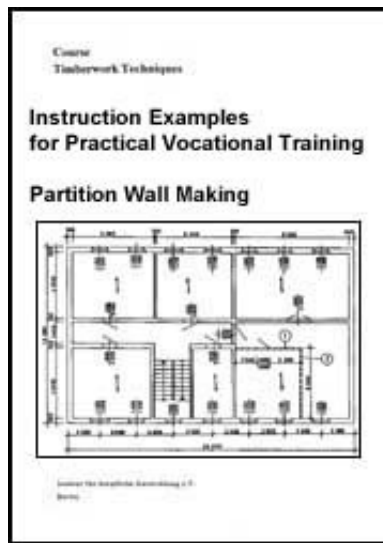

 **Partition Wall Making - Course: Timberwork techniques. Instruction examples for practical vocational training (Institut fr Berufliche Entwicklung, 35 p.)**

 **(introduction...)**

 **Preliminary Remarks**

 **➔ Instruction Example 5.1.: Calculation of the Pitch Size**

 **Instruction Example 5.2.: Scribing of the Runners**

 **Instruction Example 5.3.: Scribing of the Posts**

 **Instruction Example 5.4.: Scribing of the Stiffening Transoms**



Instruction Example 5.5.: Scribing of the Door



Instruction Example 5.6.: Assembly and Erection of the Partition Wall

Instruction Example 5.1.: Calculation of the Pitch Size

The pitch sizes for the partition wall shown in the detailed drawing are to be determined.

Known:

Room height: 2500 mm

Length of surface covering material: 2500 mm

$a_{adm} = 600$ mm

The runners are cut from 50 mm thick and 4000 mm long boards

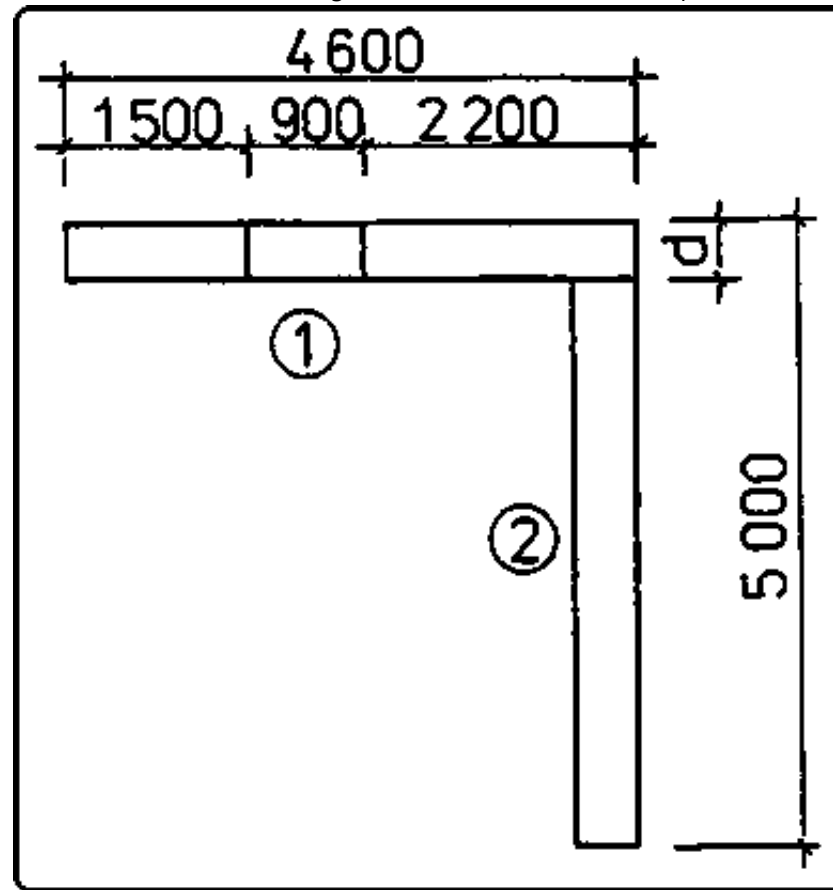

Figure

Hand tools

None

Measuring and testing means

None

Auxiliary accessories

Paper for calculations, pencil, possibly calculator

Necessary previous knowledge

Fundamental operations, reading of drawings

Sequence of operations	Comments
1. Determine the cross section of timbers for the posts.	<ul style="list-style-type: none"> - Read cross section in table 1. - Select: $b = 60 \text{ mm}$, $d = 75 \text{ mm}$. - Use squared timbers of $60/80 \text{ mm}^2$. - d for the runner thickness = 80 mm - b for the post width = 60 mm
2. Calculate the pitch size for wall (1).	
Requ.: $a_1 = a = \frac{L_t - \frac{b}{2}}{n_{Fa}}$	
Known: $L_t = \frac{G_1}{n_{Ta}}$	(2) $L_t = \frac{4600 \text{ mm}}{2}$
$b = 60 \text{ mm}$	$L_t = 2300 \text{ mm}$
$n_{Fa} = \frac{L_t - \frac{b}{2}}{a_{adm}}$	(3) $n_F = \frac{2300 \text{ mm} - \frac{60 \text{ mm}}{2}}{600 \text{ mm}} = 3.7$
$G_1 = 4600 \text{ mm}$	$n_{Fa} = 4$

$$n_{Ta} = \frac{G1}{M1}$$

$$n_{Ta} = \frac{4600\text{mm}}{2500\text{mm}} = 1.8$$

$$a_{adm} = 600 \text{ mm}$$

$$n_{Ta} = 2$$

$$M1 = 2500 \text{ mm}$$

$$(4) a_1 = \frac{2300\text{mm} - \frac{60\text{mm}}{2}}{4}$$

$$\underline{a_1} = 567.5 \text{ mm}$$

() indicates the steps of calculation.

3. Calculate the pitch size for wall (2)

- Since the partition walls meet at right angles, G1 for wall (2) is not 5000 mm!
The thickness $d = 80 \text{ mm}$ (runner thickness) is to be subtracted from $G1 = 5000 \text{ mm}$!

Requ.:
$$a_2 = a = \frac{L_t - \frac{b}{2}}{n_{Fa}}$$

Known:
$$L_t = \frac{G1}{n_{Ta}}$$

- Follow steps of solution exactly!

$$b = 60 \text{ mm}$$

$$n_{Fa} = \frac{L_t - \frac{b}{2}}{a_{adm}}$$

$$G1 = 5000 \text{ mm} - d$$

$n_{Ta} = \frac{G1}{M1}$	
$a_{adm} = 600 \text{ mm}$	
$d = 80 \text{ mm}$	(1) $G1 = 5000 \text{ mm} - 80 \text{ mm}$
$M1 = 2500 \text{ mm}$	$G1 = 4920 \text{ mm}$
	(2) $n_T = \frac{4920\text{mm}}{2500\text{mm}} = 1.9$
	$n_{Ta} = 2$
	(3) $Lt = \frac{4920\text{mm}}{2} = \underline{2460\text{mm}}$
	(4) $n_F = \frac{2460\text{mm} - \frac{60\text{mm}}{2}}{600\text{mm}} = 4.05!$
	$n_{Fa} = 5!$
	(5) $a_2 = \frac{2460\text{mm} - \frac{60\text{mm}}{2}}{5}$
	$a_2 = \underline{486 \text{ mm}}$



[Home](#) > [ar](#).[cn](#).[de](#).[en](#).[es](#).[fr](#).[id](#).[it](#).[ph](#).[po](#).[ru](#).[sw](#)

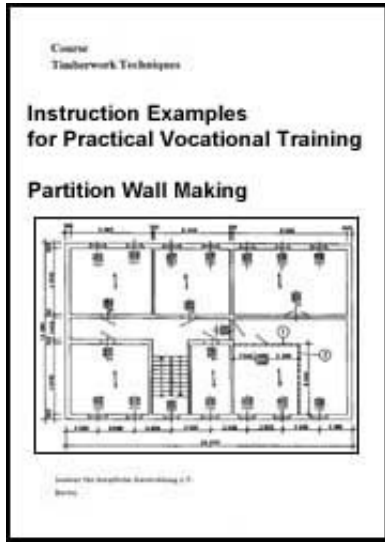

Partition Wall Making - Course: Timberwork techniques. Instruction examples for practical vocational training (Institut für Berufliche Entwicklung, 35 p.)

 **(introduction...)**

 **Preliminary Remarks**

 **Instruction Example 5.1.: Calculation of the Pitch Size**

 **➔ Instruction Example 5.2.: Scribing of the Runners**

 **Instruction Example 5.3.: Scribing of the Posts**

 **Instruction Example 5.4.: Scribing of the Stiffening Transoms**

 **Instruction Example 5.5.: Scribing of the Door Framework**

 **Instruction Example 5.6.: Assembly and Erection of the Partition Wall**

Instruction Example 5.2.: Scribing of the Runners

The foot and head runners for the partition wall shown in the detailed drawing are to be scribed.

Known:

Runner thickness: 80 mm

Runner height: 50 mm

Post width: 50 mm

Joint post width: 80 mm

Door size: 900/200 mm²

Pitch size for

wall (1) = 567.5 mm

wall (2) = 468 mm

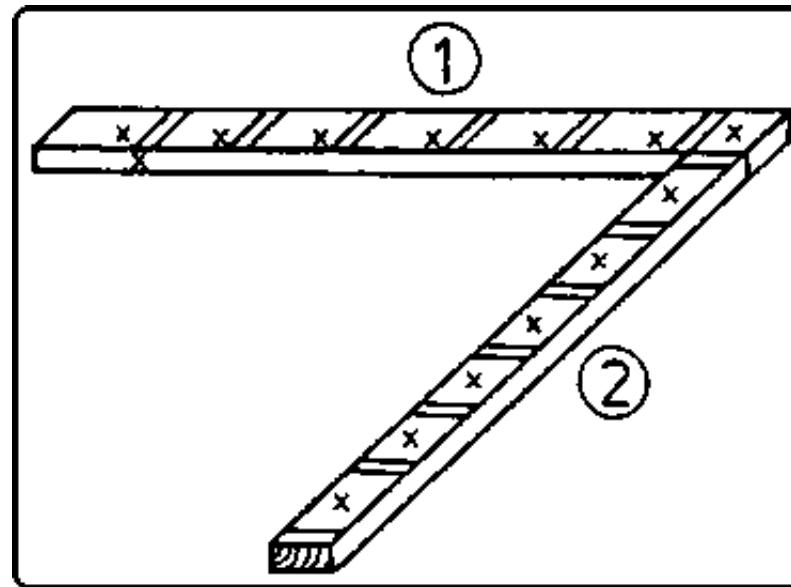

Figure

Hand tools

Hammer

Measuring and testing means

Folding rule, carpenter's square

Auxiliary accessories

Pencil, template for post width, marking gauge, abrasive paper, one-ell trestles

Necessary previous knowledge

Reading of drawings, scribing, measuring, angling

Remarks to the working drawing

A head, B foot

Sequence of operations	Comments
1. Decide on the joining side of the runners.	
2. Put runners for wall (2) on the trestles.	<ul style="list-style-type: none"> - Mind position of joining side. (See Fig. 18 in Trainees' Handbook of lessons.) - Put runners closely together. - Put runners about flush at left ends. - Select distance of trestles so that runners cannot tilt up when scribing.
3. Scribe shortening at left ends of runners and mark with section mark.	<ul style="list-style-type: none"> - Go to the right only as far as necessary to produce a right-angle section. - Place long leg of square at the longitudinal side of the runner at the front. <p>Scribe a thin line only.</p>
4. Measure-in the pitch size.	- Mark only at the front edge of the runner at the front.

	<ul style="list-style-type: none"> - Measure cumulatively. - Check the total length. (If markings do not fit into total length, find measuring error and make correction!) - Remove or delete wrong markings.
5. Scribe pitch size and mark with jointing mark.	<ul style="list-style-type: none"> - Use the square. - Make sure that the square is placed correctly. - Mark with jointing mark at the correct side of scribed line! (work from jointing)
6. Scribe the post width.	<ul style="list-style-type: none"> - Use a template (piece of board having the exact width of the post). - Scribe from jointing!
7. Measuring-in the posts for the door, scribe and mark with "T".	<ul style="list-style-type: none"> - The sizes given in the detailed drawing are all finished sizes! - The clear size for the door opening is to be scribed bigger at both sides because the door reveal will be provided with panelling (lining)!
8. Measure-in and scribe the additional post.	<ul style="list-style-type: none"> - Measure the thickness of the surface material for the wall covering plus post width from the foot runner of wall (2) to the left!
9. Scribe the mortise width.	<ul style="list-style-type: none"> - Use a marking gauge. - Scribe from the joining side of the runners!
10. Scribe the corner tenons.	<ul style="list-style-type: none"> - Corner tenons are to be provided at <ul style="list-style-type: none"> • wall posts,

	<ul style="list-style-type: none"> • corner posts, • door post, • door fixing post.
<p>11. Delete scribed post lines on the foot runner which are not needed.</p>	<ul style="list-style-type: none"> - Posts in the area of the door opening. - Delete with wavy line or abrase by means of abrasive paper.
<p>12. Put runner for wall (2) on the trestles and scribe.</p>	<ul style="list-style-type: none"> - Repeat steps 2., 3., 4., 5., 6., 9. and 10. accordingly! <p>If door openings are required in a partition wall to be built, the mortises are to be numbered on the head runner starting from the left.</p> <p>The numbers are to be marked on the side opposite the jointing mark.</p>

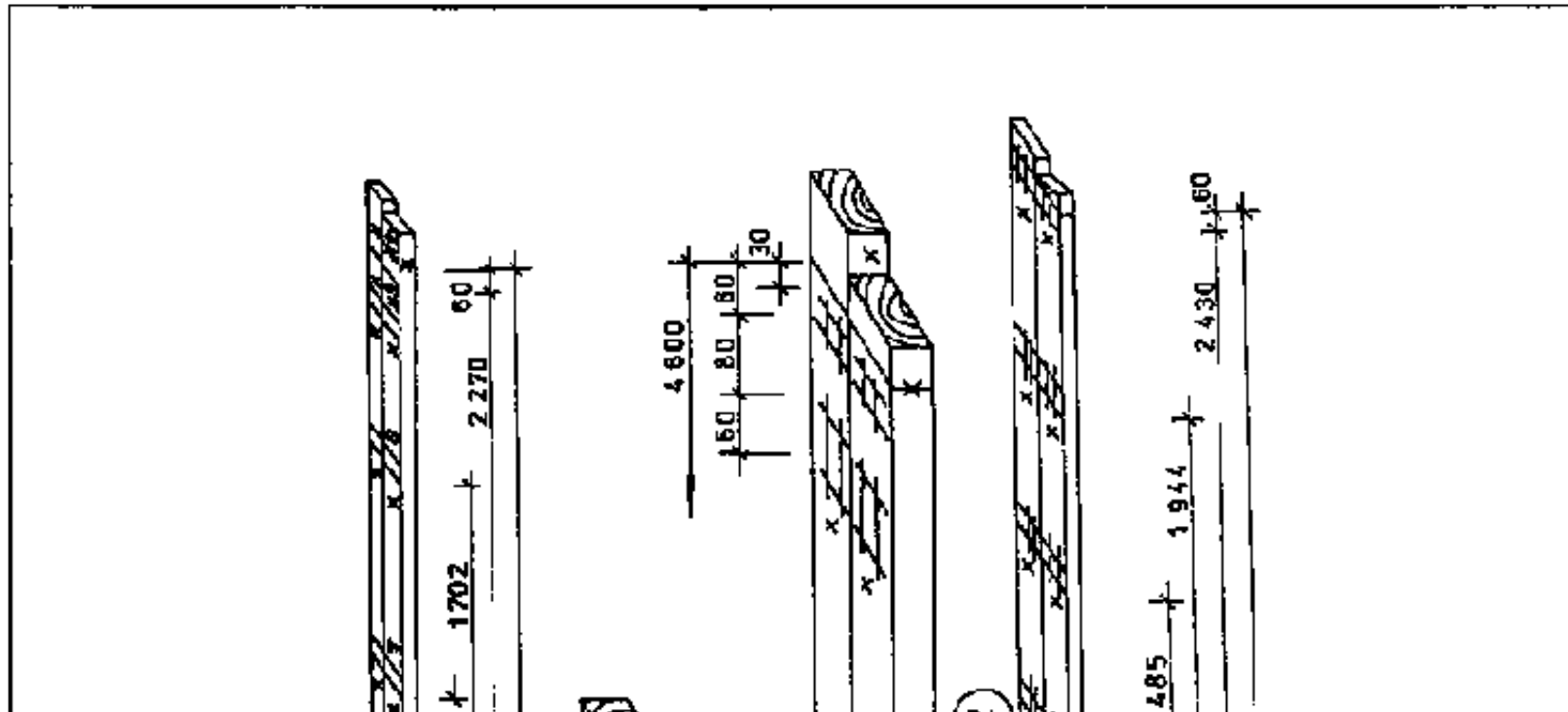

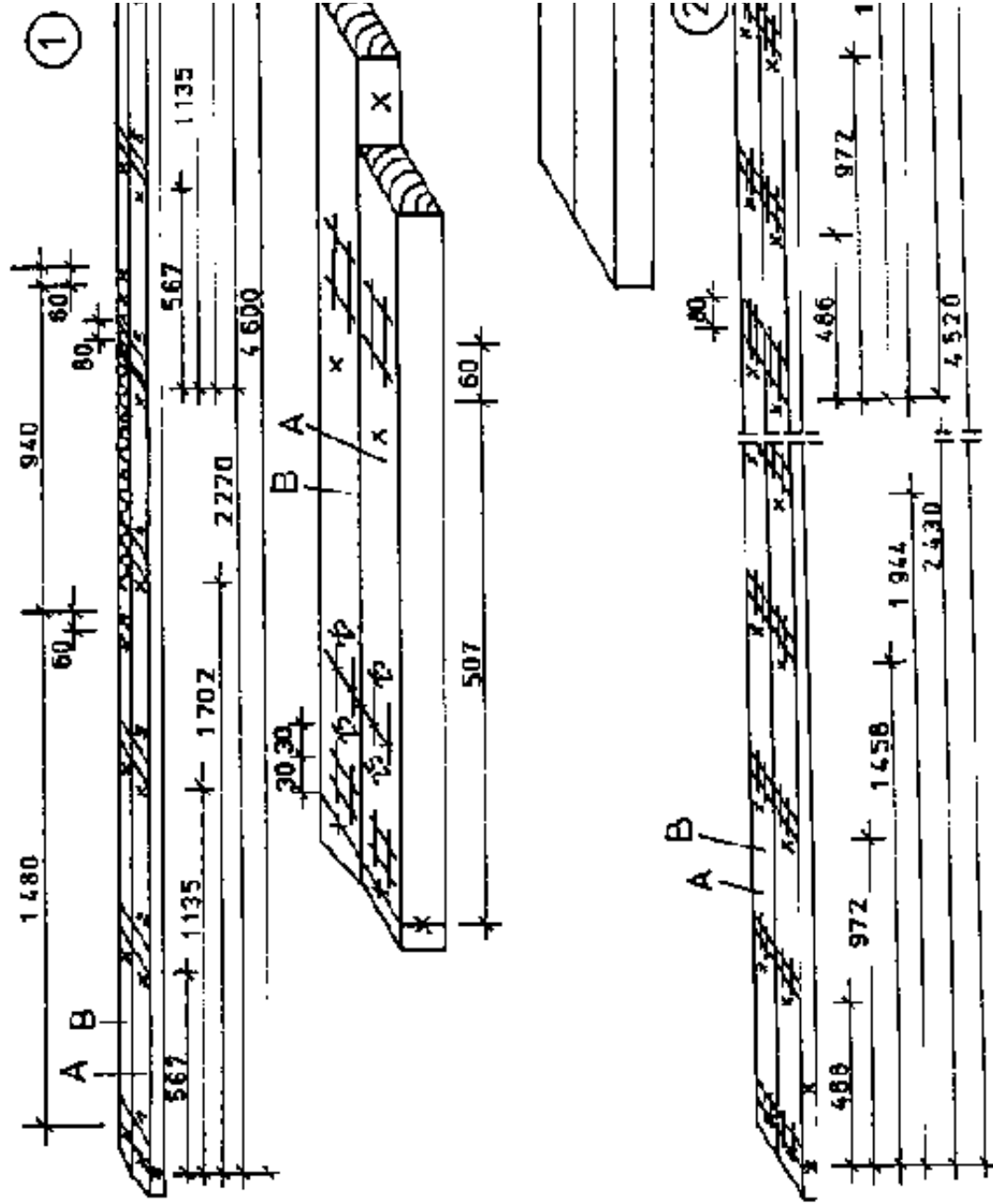









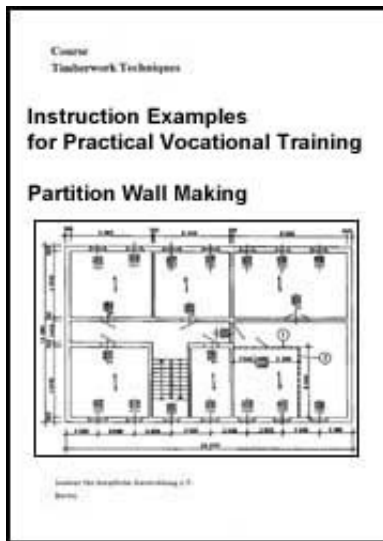

				5.2.
IBE	Scribing of the foot and head runners			3605

Scribing of the foot and head runners



[Home](#) > [ar](#).[cn](#).[de](#).[en](#).[es](#).[fr](#).[id](#).[it](#).[ph](#).[po](#).[ru](#).[sw](#)



-  **Partition Wall Making - Course: Timberwork techniques. Instruction examples for practical vocational training (Institut fr Berufliche Entwicklung, 35 p.)**
-  **(introduction...)**
-  **Preliminary Remarks**
-  **Instruction Example 5.1.: Calculation of the Pitch Size**
-  **Instruction Example 5.2.: Scribing of the Runners**
-  **Instruction Example 5.3.: Scribing of the Posts**
-  **Instruction Example 5.4.: Scribing of the Stiffening Transoms**
-  **Instruction Example 5.5.: Scribing of the Door Framework**
-  **Instruction Example 5.6.: Assembly and Erection of the Partition Wall**

Instruction Example 5.3.: Scribing of the Posts

The posts for the partition wall shown in the detailed drawing are to be scribed.

Known:

Joint post: $b = 80$ mm, $d = 80$ mm

Posts: $b = 60$ mm, $d = 80$ mm

Stiffening transoms: $b = 50$ mm, $d = 80$ mm

Runner height = 50 mm

Room height = 2500 mm

The number of the posts is taken from the foot runners.

Wall (1): 10 posts

Wall (2): 10 posts

1 joint post

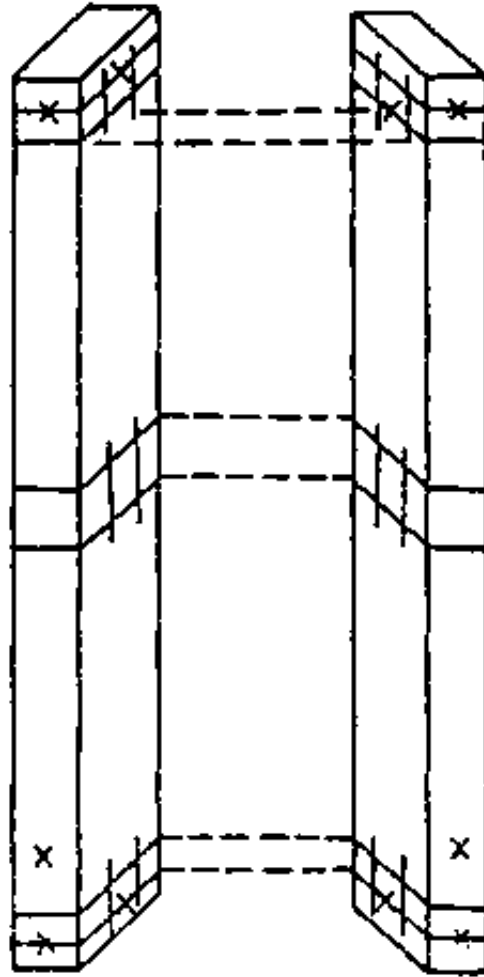

Figure

Hand tools

Hammer

Measuring and testing means

Folding rule, carpenter's square

Auxiliary accessories

Pencil, marking gauge, abrasive paper, one-ell trestless

Necessary previous knowledge

Reading of drawings, measuring, angling, scribing

Remarks: The joint tail post in wall (1) is dealt with in Instruction Example 5.5.!

Sequence of operations	Comments
1. Decide on the joining side of the posts and mark it.	
2. Put the posts on the trestles.	<ul style="list-style-type: none"> - Do not put on more than 5 posts. - Place the posts with the joining side on top. - Put the posts closely together and about flush at the left ends. - Include joint post, door post and corner post.
3. Scribe shortening at left ends of the posts and mark with section mark.	<ul style="list-style-type: none"> - Go to the right only as far as necessary to produce a right-angle section.
4. Measure-in and mark the tenon length, measure-in and mark the lower edge of stiffening transom, measure-in and mark the upper edge of stiffening	<ul style="list-style-type: none"> - Measure cumulatively! (20 - 1195 - 1245 - 2420 - 2440 mm).

transom, measure-in and mark the tenon length.

- Check the two outer markings with the total length.
- Total length:
room height minus two runner heights plus two tenon lengths
(2500 - 2 • 50 + 2 • 20) mm = 2440 mm.
- If the sizes (total length and the two outer marking) do not correspond, find the measuring error and make correction.
- Abrase wrong markings to avoid scribing errors!

5. Scribe all markings over the posts put on the trestles.

- Scribe thin lines.
- Place long leg of carpenter's square at the post put at the front.
- Mark the sections at both ends.

6. Check the scribed lines.

- Place the post from the front at the post at the rear and check the scribed lines.

7. Scribe the tenon parapets.

- Move the posts apart so that the marking gauge can be used for scribing without hindrance.
- Scribe from the joining side.
- Do not cant the marking gauge.

	<ul style="list-style-type: none"> - Scribe at the left ends of the posts all front parapets (at jointing) first, then all rear parapets and then
8. Scribe the stiffening	<p>scribe all parapets at the right ends.</p> <ul style="list-style-type: none"> - Angle at both sides the scribed lines for stiffening transoms on posts. - Put long leg of square on joining side. - Scribe thin lines.
9. Scribe the mortises for stiffenings transoms.	<ul style="list-style-type: none"> - Use marking gauge. - Scribe from the joining side. - First scribe all front parapets at both sides, then all rear parapets at both sides. - Do not cant the marking gauge.
10. Scribe the corner tenons.	<ul style="list-style-type: none"> - Scribe only wall posts and corner posts. - Mind the joining side and, in particular, mirror image of corner tenons.
11. Remove the scribed posts from the trestles and put on the next ones for scribing.	<ul style="list-style-type: none"> - Do <u>not</u> take off the post at the front! - It is used as template for the posts to be scribed. - Do not exceed the maximum

number to be put on.
- Joining side to be on top!
- Put the posts closely together and about flush at the left ends.

12. Scribe the posts.

- Place the scribed post (template) and transfer all scribed lines onto the posts put on the trestles.
- Place exactly.
- Check the scribed lines.
- Repeat steps 7., 8. and 9. above, accordingly.
If more posts are required, steps 11. and 12. above are to be repeated always using the same post as template.

13. Number the posts for wall (1).

- Take numbering from head runner.
- Number at lower end of posts.
- Start numbering from the left.
- Mind right-hand corner post (to be provided with last number).
- While the door posts have been scribed, they are not to be numbered.

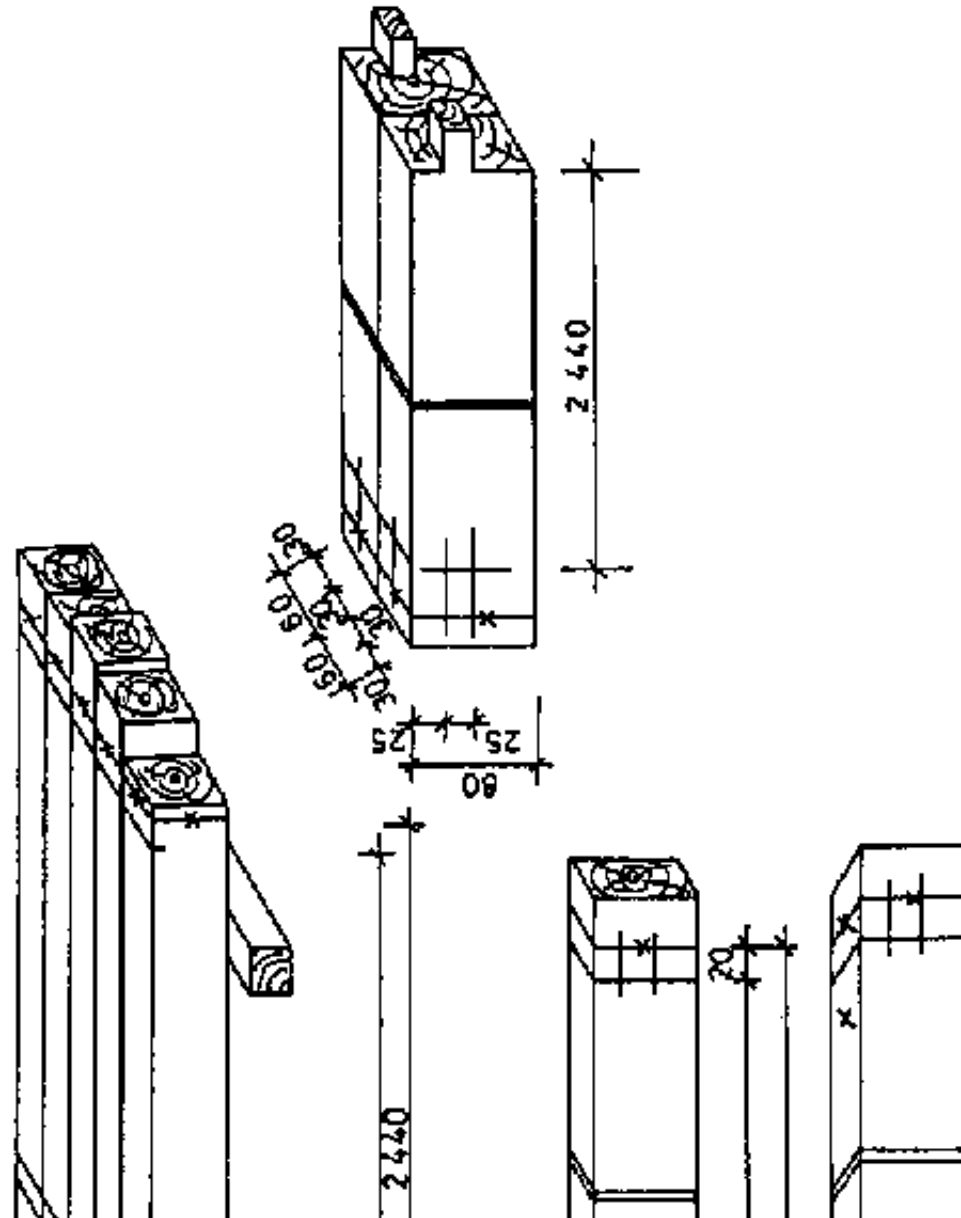

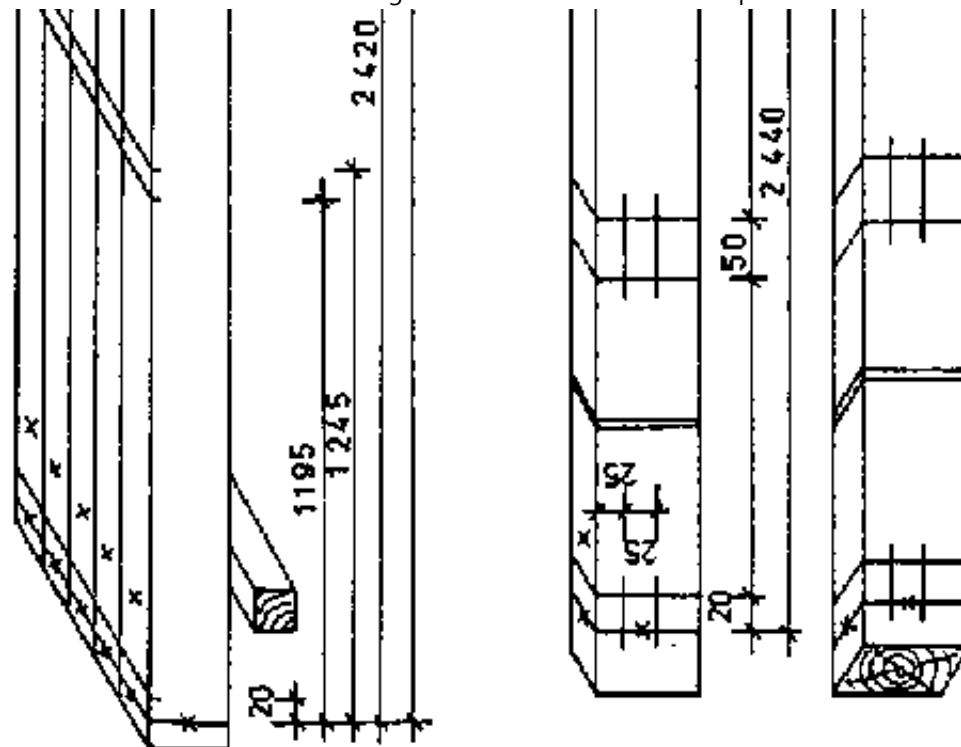

				5.3.
IBE	Scribing of the posts			3605

Scribing of the post



[Home](#) > [ar](#).[cn](#).[de](#).[en](#).[es](#).[fr](#).[id](#).[it](#).[ph](#).[po](#).[ru](#).[sw](#)

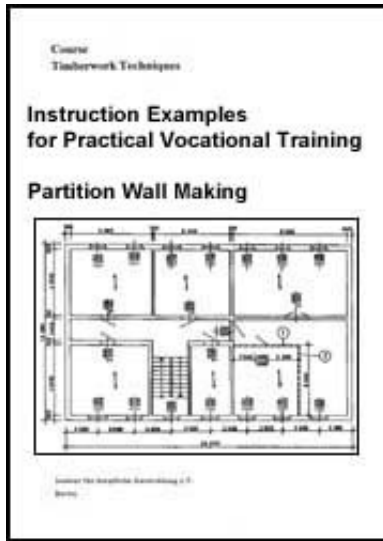



 **Partition Wall Making - Course: Timberwork techniques. Instruction examples for practical vocational training (Institut fr Berufliche Entwicklung, 35 p.)**

 **(introduction...)**

 **Preliminary Remarks**

 **Instruction Example 5.1.: Calculation of the Pitch Size**

 **Instruction Example 5.2.: Scribing of the Runners**

 **Instruction Example 5.3.: Scribing of the Posts**

 **Instruction Example 5.4.: Scribing of the Stiffening Transoms**

 **Instruction Example 5.5.: Scribing of the Door Framework**

 **Instruction Example 5.6.: Assembly and Erection of the Partition Wall**

Instruction Example 5.4.: Scribing of the Stiffening Transoms

The stiffening transoms for the partition wall shown in the detailed drawing are to be scribed.

Known:

- **One transom in the wall at half height of room.**
- **Transom timber height: 50 mm**
- **Transom timber thickness: 80 mm**
- **Transom timber length: 5000 mm**

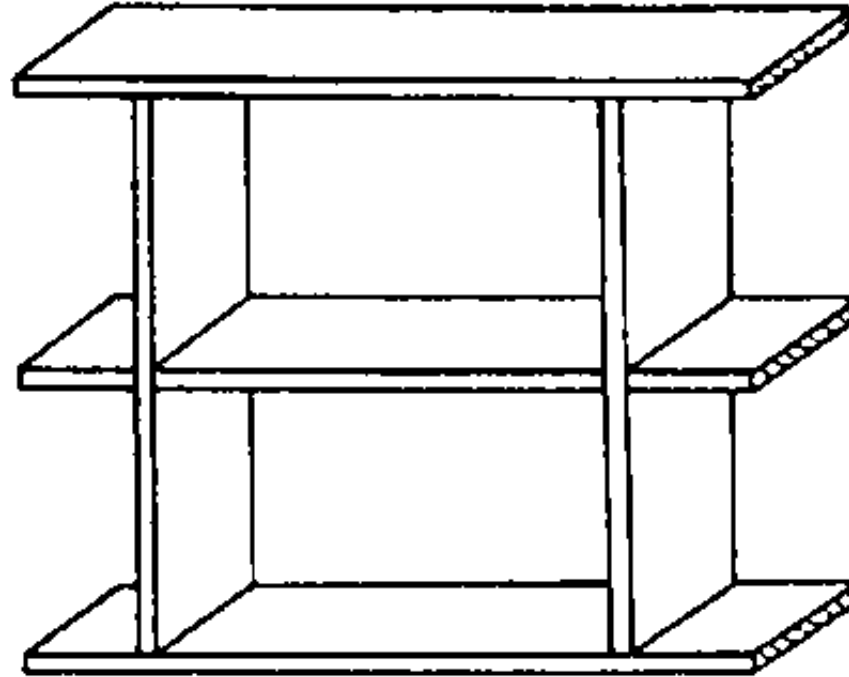

Figure

Hand tools

Hammer

Measuring and testing means

Folding rule, carpenter's square

Auxiliary accessories

Pencil, marking gauge, abrasive paper, one-ell trestles

Necessary previous knowledge

Reading of drawings, measuring, angling, scribing

Sequence of operations	Comments
1. Put transom timber and foot runner for wall (1) on the trestles.	- Put the two timbers closely together and about flush at the left ends.
2. Scribe the stiffening transom lengths.	<ul style="list-style-type: none"> - Use the foot runner as template. - Place the long leg of carpenter's square at foot runner and transfer all scribed lines (except for section lines) onto transom timber. - Include door posts. - Provide each scribed stiffening transom with jointing mark at the transom height.
3. Measure-in and scribe the tenon length.	<ul style="list-style-type: none"> - Start at the right scribed line of the left corner post and measure-in and scribe to the left. - Mark the scribed line with section mark. - On the second to eighth post, scribe from the left scribed line to the right and from the right scribed line to the left and mark with section mark. - Do not scribe tenon length between the door posts.

4. Scribe the tenon parapets.	<ul style="list-style-type: none"> - Remove the foot runner to provide freedom to move for scribing. - Start from the joining side, scribe all front parapets and then all rear parapets. <p>Use marking gauge and do not cant it when scribing.</p>
5. Angle at the sides and scribe the necessary lines.	<ul style="list-style-type: none"> - Put long leg of square on the transom timber and scribe downwards at both sides. - Mark the section lines.
6. Put the transom timber and foot runner for wall (2) on the trestles.	<ul style="list-style-type: none"> - Proceed as with step 1. above.
7. Scribe the stiffening transom.	<ul style="list-style-type: none"> - Repeat steps 2., 3., 4. and 5. above, accordingly.

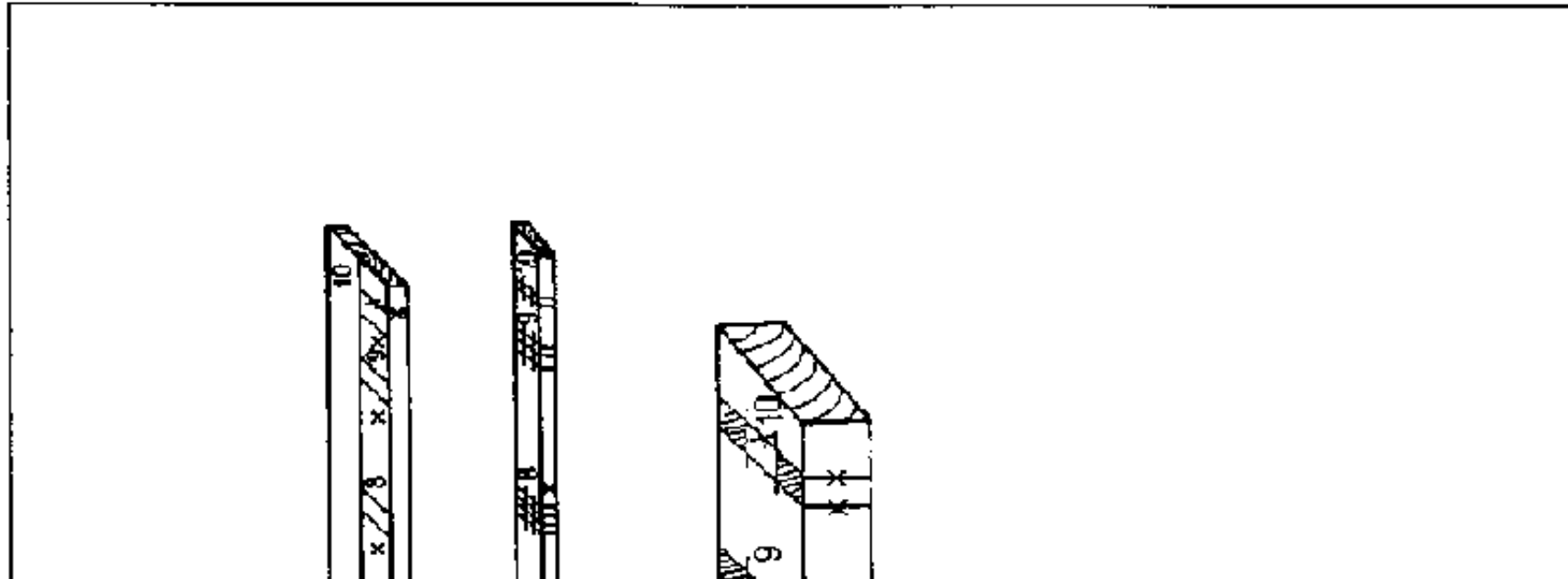

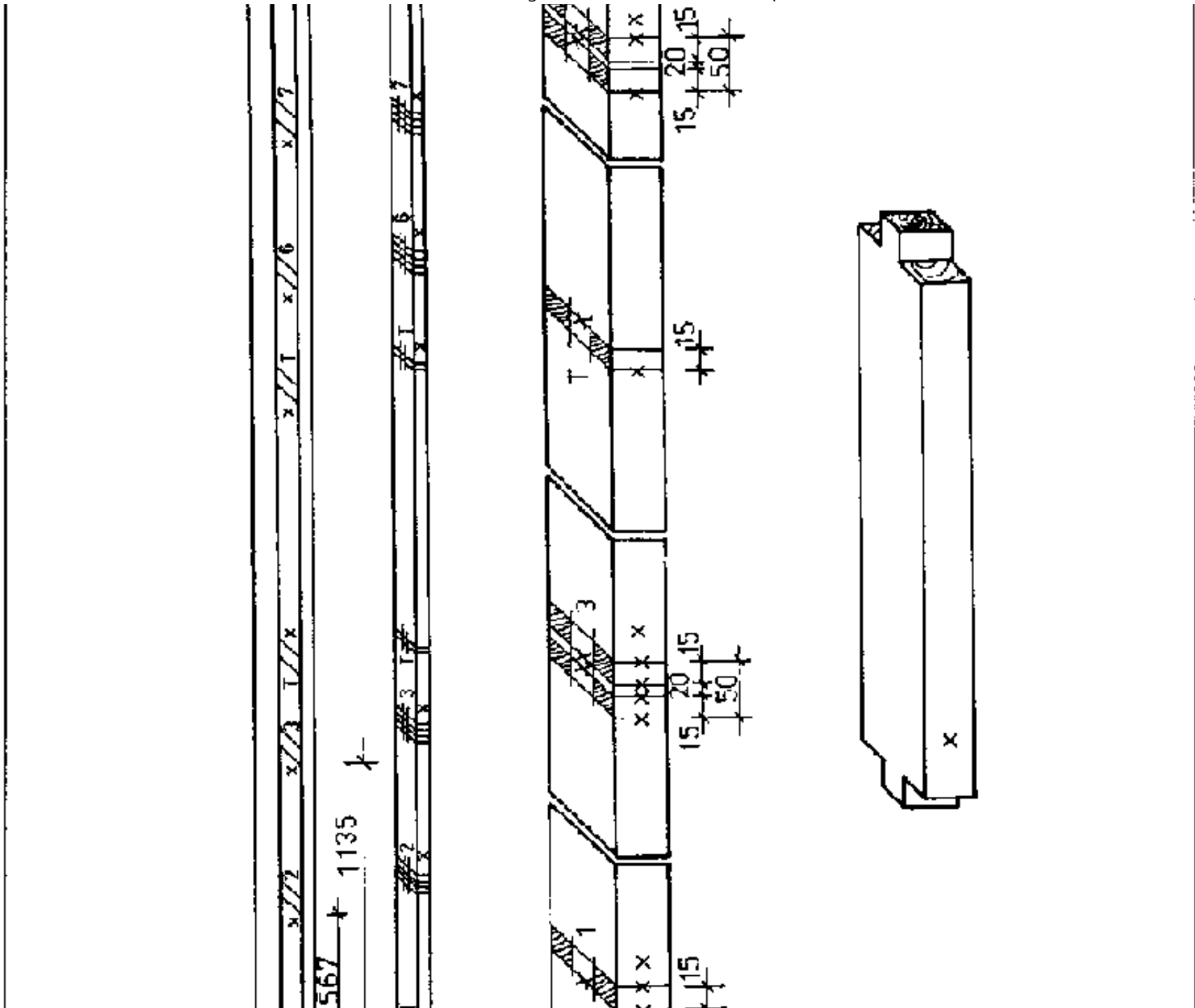



				5.4.
IBE	Scribing of the stiffening transoms			3605





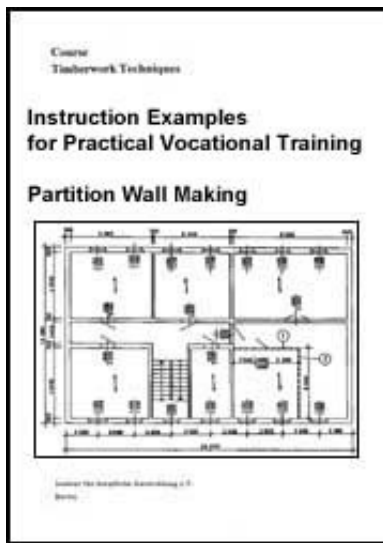

Scribing of the stiffening transoms



[Home](#) > [ar](#).[cn](#).[de](#).[en](#).[es](#).[fr](#).[id](#).[it](#).[ph](#).[po](#).[ru](#).[sw](#)



 **Partition Wall Making - Course: Timberwork techniques. Instruction examples for practical vocational training (Institut fr Berufliche Entwicklung, 35 p.)**

-  **(introduction...)**
-  **Preliminary Remarks**
-  **Instruction Example 5.1.: Calculation of the Pitch Size**
-  **Instruction Example 5.2.: Scribing of the Runners**
-  **Instruction Example 5.3.: Scribing of the Posts**
-  **Instruction Example 5.4.: Scribing of the Stiffening Transoms**



Instruction Example 5.5.: Scribing of the Door



Framework

Instruction Example 5.6.: Assembly and Erection of the Partition Wall

Instruction Example 5.5.: Scribing of the Door Framework

The door framework for the partition wall (1) is to be scribed.

Known:

- **Door height: 2000 mm**
- **Door width: 900 mm**
- **Door posts are already scribed.**
- **Door lintel transom size**

$$\mathbf{d = 80 \text{ mm}, h = 50 \text{ mm}, l = 1800 \text{ mm}}$$

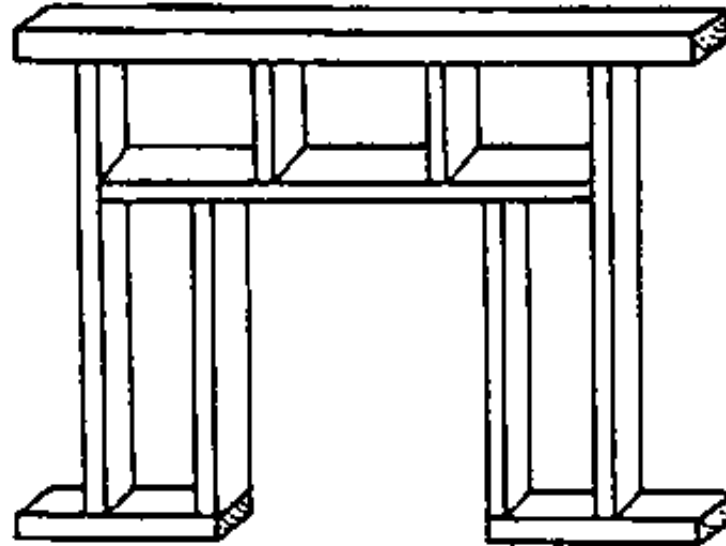

Figure

Hand tools

Hammer

Measuring and testing means

Folding rule, carpenter's square

Auxiliary accessories

Pencil, marking gauge, abrasive paper, one-ell trestles

Necessary previous knowledge

Measuring, angling, scribing, reading of drawings

Sequence of operations	Comments
1. Put posts 3 and 6, as well as door posts "4" and "5" on the trestles.	<ul style="list-style-type: none"> - Place the scribed lines flush. - Jointing marks to be at the left and on top. - Sequence is important! Start at front: Post 3 door post "4" door post "5" post 6.
2. Measure-in position of door lintel transom, scribe and mark.	<ul style="list-style-type: none"> - Measure from surface of floor. Scribing size: clear door height minus foot runner plus 20 mm allowance for jamb lining (2000 mm - 50 mm + 20 mm = <u>1970 mm</u>) <ul style="list-style-type: none"> - Measure-in the size on the post at the front, place the square and scribe.
3. Take out the door posts and move posts 3 and 6 closely together.	<ul style="list-style-type: none"> - Leave the door posts on the trestles. - Do not change the jointing marks. - Put the scribed lines of posts 3 and 6 flush. - Post 3 to remain at the front!
4. Measure-in and scribe the lintel transom height.	<ul style="list-style-type: none"> - Use the square.
5. Scribe the mortises.	<ul style="list-style-type: none"> - Scribe from the joining side. - Scribe only on the front side of post 3 and onto the rear side of post 6.

6. Scribe and mark the tenon length on the door posts.	<ul style="list-style-type: none"> - Use the marking gauge; do not cant it. - Measure and scribe from the scribed door lintel transom line towards the head runner. - Mark the scribed line with section mark.
7. Scribe the tenon parapets.	<ul style="list-style-type: none"> - Scribe the front and rear parapets from the joining side. - Delete or abrase the scribed mortise lines for the stiffening transoms on the side opposite the corner tenon.
8. Put the door lintel transom on the trestles and mark with jointing mark.	<ul style="list-style-type: none"> - Scribe the joining side at door lintel transom height
9. Scribe the shortening and mark with section mark.	<ul style="list-style-type: none"> - Go only as far as necessary to produce a right-angle section.
10. Measure-in and scribe the tenon length and door lintel transom length.	<ul style="list-style-type: none"> - Measure-in and scribe the tenon length at the left end. - Measure-in and scribe the door lintel transom lengths (Take the length from the head runner! Clear size between the posts 3 and 6). - Measure-in the tenon length at the right end, scribe and mark with section mark.
11. Scribe the tenon parapets.	<ul style="list-style-type: none"> - Scribe the front and rear parapets from the joining side.
12. Scribe the mortises for the tail posts.	<ul style="list-style-type: none"> - Scribe on the top face of the door lintel transom!!! - Take the sizes from the head runner. (Place batten to contact post 3 and transfer scribed lines onto batten). - Scribe tenon parapet and mortise width from the joining

	side.
13. Scribe the mortises for the door posts.	<p>- Use the marking gauge and do not cant it.</p> <p>- Scribe on the bottom face of the door lintel transom!</p> <p>- Take the sizes from the foot runner.</p> <p>(Place batten to contact post 3 and transfer scribed lines onto batten).</p> <p>- Scribe the tenon parapet and mortise width from the joining side.</p> <p>- Use the marking gauge.</p>
14. Scribe the tail posts.	<p>- Use the sections of the door posts.</p> <p>- Take the size from post 3 and transfer it to the tail post.</p> <p>- For the joint tail post, a cover strap of 20 mm thickness is to be nailed on the erected partition wall at the side of the joint tail post opposite the jointing mark.</p>

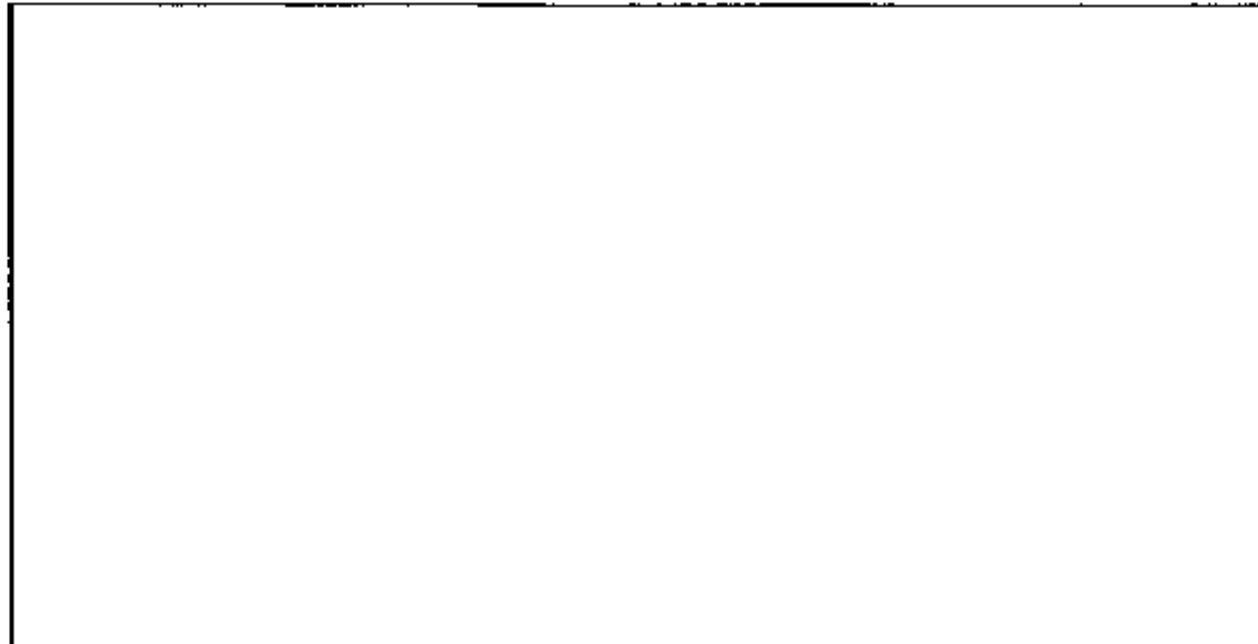

				5.5.
IBE	Scribing of the door framework			3605

Scribing of the door framework



[Home](#) > [ar.cn.de.en.es.fr.id.it.ph.po.ru.sw](#)

 **Partition Wall Making - Course: Timberwork techniques.**

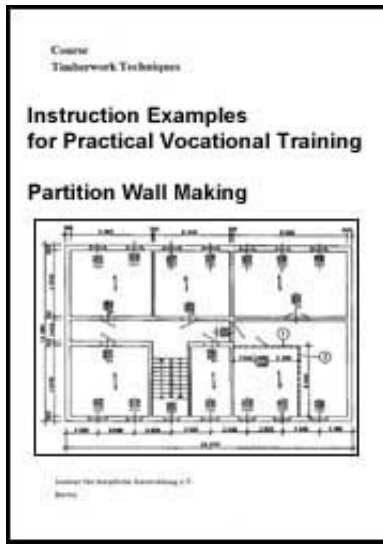



Instruction examples for practical vocational training (Institut für Berufliche Entwicklung, 35 p.)

 **(introduction...)**

 **Preliminary Remarks**

 **Instruction Example 5.1.: Calculation of the Pitch Size**

 **Instruction Example 5.2.: Scribing of the Runners**

 **Instruction Example 5.3.: Scribing of the Posts**

 **Instruction Example 5.4.: Scribing of the Stiffening Transoms**

 **Instruction Example 5.5.: Scribing of the Door Framework**

  **Instruction Example 5.6.: Assembly and Erection of the Partition Wall**

Instruction Example 5.6.: Assembly and Erection of the Partition Wall

The partition wall shown in the detailed drawing shall be built-in.

It is assumed that:

- **all structural components have been provided with the necessary wood joints,**

- **all structural components have been made available in the existing room, where the partition wall is to be built in, in assorted stacks.**

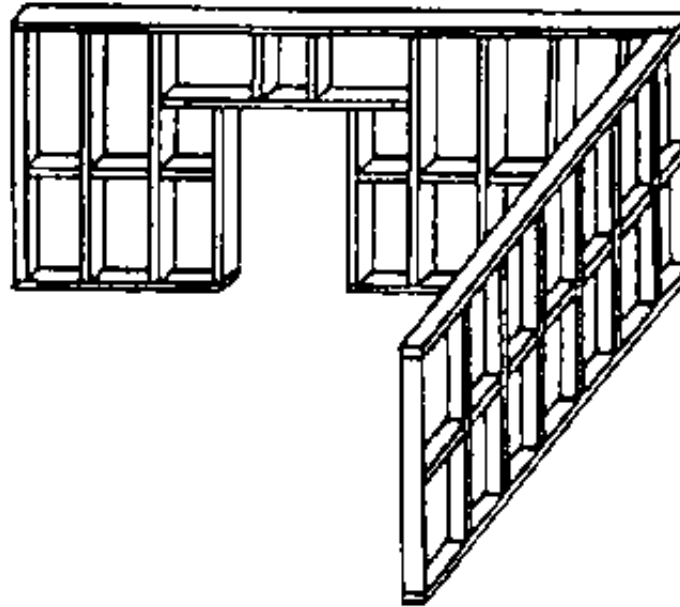

Figure

Hand tools

Hammer, hand saw, firmer chisel

Measuring and testing means

Folding rule, carpenter's square, water-level

Auxiliary accessories

Pencil, 3.4/80 nails, wooden wedges, cover strap 80 mm wide, 20 mm thick and 450 mm long, scaffolding material (two one-ell trestles, scaffolding boards 200 mm wide, 4000 mm long, 5 pcs.), cleats, drawing

Necessary previous knowledge

Aligning of timberwork

Sequence of operations	Comments
1. Scribe alignment lines on the floor.	<ul style="list-style-type: none"> - Lay out the foot runners. - Mind the joining side of runner (1) (door size is fixed). - Read the sizes for the position of the walls in the drawing and set the runners accordingly. - Scribe along the runners at the joining side and provide scribed lines with mark (bird's-mouth). - Decide on the wall to be erected first based on how the foot runners meet and on the existing building clearance (see drawing)!
2. Put the foot runner (1) on the floor near the scribed line.	<ul style="list-style-type: none"> - Think of door size! - In this example the joining side lies on the floor.
3. Mount wall post in foot runner.	<ul style="list-style-type: none"> - Pay attention to joining side and jointing mark of post. - Plug tenon into mortise and, if necessary, hammer in gently. - When hammering put cleat on tenon parapet. - Do not forcefully hammer the post into the mortise to avoid splitting of the wood! - If tenon does not fit in spite of gentle hammering, re-work tenon or mortise by means of firmer chisel.
4. Mount stiffening transom in	<ul style="list-style-type: none"> - Pay attention to the joining side.

5. Mount post 2 in foot runner.	<p>See comments on step 3 above!</p> <ul style="list-style-type: none"> - Plug tenon of stiffening transom into mortise of post. - See step 3.
6. Mount stiffening transom in post 2.	
7. Mount post 3.	
8. Mount door post and door fixing post in foot runner.	
9. Mount door lintel transom.	<ul style="list-style-type: none"> - Pay attention to joining side!
10. Mount posts and stiffening transoms successively up to corner post.	<ul style="list-style-type: none"> - See comments on step 3.
11. Mount tail posts in door lintel transom.	<ul style="list-style-type: none"> - Pay attention to joining side. - Plug mortises on tenons from the left end of the runner and hammer-on the runner. - Underlay cleat when hammering. - Hammer sensitively, otherwise joints may part again. - Slightly enter all tenons into mortises successively first and then hammer-on the runner tightly.
13. Nail the tenons.	<ul style="list-style-type: none"> - Check the joint for close fit, press together again, if necessary. - Drive-in the nail in oblique but horizontal position. (There must be sufficient wood at the joining side but the nail must still penetrate the tenon!)
14. Erect the wall (1).	<ul style="list-style-type: none"> - Press the wall upwards at both sides.

	<ul style="list-style-type: none"> - Ensure equal pressure at the corner post and wall post! The nailed joints must not loosen again.
15. Align wall (1) to alignment line and perpendicularly.	<ul style="list-style-type: none"> - Move foot runner according to scribed marking on the floor (hammer gently, if necessary). - Joining side must be flush with scribed line on the floor. - Use water-level for perpendicular alignment.
16. Wedge the erected wall.	<ul style="list-style-type: none"> - Drive-in wooden wedges between ceiling and head runner. - Do not shorten wedges yet.
17. Put foot runner of wall (2) on the floor near the scribed line.	<ul style="list-style-type: none"> - Pay attention to joining side.
18. Mount the corner post.	<ul style="list-style-type: none"> - Pay attention to jointing mark. - See comments on the assembly of wall (1)!
19. Mount posts and stiffening transoms successively up to wall post.	<ul style="list-style-type: none"> - Pay attention to joining side and jointing mark.
20. Nail the tenons.	<ul style="list-style-type: none"> - Place nails in oblique position.
21. Align wall (2) to alignment line on the floor and perpendicularly.	<ul style="list-style-type: none"> - If necessary, drive wall (1) a little outwards at the corner post so that wall (2) can be driven in. Then drive wall (1) to wall (2) again.
22. Wedge the two walls between ceiling and head runner.	<ul style="list-style-type: none"> - Work from trestle scaffolding. - Slightly hammer the wedges and scribe the runner edge.

- Successively loosen, saw-off and drive-in again the wedges, one after another.
- For tightening, use a wooden section to be put on the cross-grained wood of the wedge.
- Do not drive in the wedges forcefully.
- Wedge at both sides of the head runner.

