

[Home](#) > [ar.cn.de.en.es.fr.id.it.ph.po.ru.sw](#)

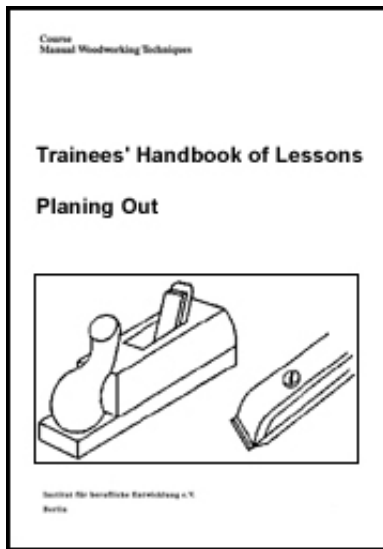





- ➔ **Planing out - Course: Manual woodworking techniques. Trainees' handbook of lessons (Institut für Berufliche Entwicklung, 18 p.)**
- ➔ **(introduction...)**
 - ➔ **1. Purpose and Application of Planing**
 - ➔ **2. Construction and Mode of Action of the Planes, Types of Planes**
 - ➔ **3. Preparations for Planing**
 - ➔ **4. Planing of Wide Faces**
 - ➔ **5. Planing of Narrow Faces**
 - ➔ **6. Planing of End-grained Narrow Faces (Sectional Areas)**
 - ➔ **7. Planing of Profiles**



[Home](#) > [ar.cn.de.en.es.fr.id.it.ph.po.ru.sw](#)

- ➔ **Planing out - Course: Manual woodworking techniques. Trainees' handbook of lessons (Institut für Berufliche Entwicklung, 18 p.)**
- ➔ **(introduction...)**
 - ➔ **1. Purpose and Application of Planing**
 - ➔ **2. Construction and Mode of Action of the Planes, Types of Planes**



-  **3. Preparations for Planing**
-  **4. Planing of Wide Faces**
-  **5. Planing of Narrow Faces**
-  **6. Planing of End-grained Narrow Faces (Sectional Areas)**
-  **7. Planing of Profiles**

**Institut für berufliche Entwicklung e.V.
Berlin**

**Original title:
Arbeitsmaterial für den Lernenden
"Aushobeln"**

Author: Rolf Jakoby

First edition © IBE

**Institut für berufliche Entwicklung e.V.
Parkstraße 23
13187 Berlin**

Order No.: 93-35-3304/2











[Home](#) > [ar](#).[cn](#).[de](#).[en](#).[es](#).[fr](#).[id](#).[it](#).[ph](#).[po](#).[ru](#).[sw](#)



 **Planing out - Course: Manual woodworking techniques. Trainees' handbook of lessons (Institut für Berufliche Entwicklung, 18 p.)**

 **(introduction...)**

-   **1. Purpose and Application of Planing**
-  **2. Construction and Mode of Action of the Planes, Types of Planes**
-  **3. Preparations for Planing**
-  **4. Planing of Wide Faces**
-  **5. Planing of Narrow Faces**
-  **6. Planing of End-grained Narrow Faces (Sectional Areas)**
-  **7. Planing of Profiles**

1. Purpose and Application of Planing

Planing is a form of cutting woodworking for surfaces. It makes it possible to

- **manufacture flat surfaces,**
- **smooth wood surfaces,**
- **shape wood and wood-based materials.**

Planing is conducive to improve quality with regard to

- surface finish of wood surfaces
- accuracy-to-size,
- accuracy of fit of connecting surfaces,
- special shaping.



[Home](#) > [ar.cn.de.en.es.fr.id.it.ph.po.ru.sw](#)

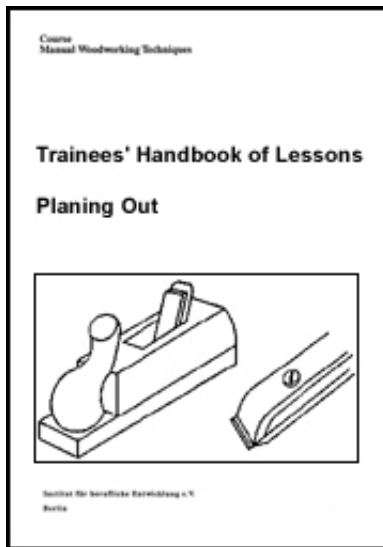

Planing out - Course: Manual woodworking techniques. Trainees' handbook of lessons (Institut für Berufliche Entwicklung, 18 p.)

 *(introduction...)*

 1. Purpose and Application of Planing

 2. Construction and Mode of Action of the Planes, Types of Planes

 3. Preparations for Planing

 4. Planing of Wide Faces

 5. Planing of Narrow Faces

 6. Planing of End-grained Narrow Faces (Sectional Areas)

 7. Planing of Profiles

2. Construction and Mode of Action of the Planes, Types of Planes

Planes have nearly all the same basic shape. The parts of the plane are as follows:

- plane stock (body),
- handle,
- plane hole with opening in the plane face,
- plane iron with flap,
- wedge,
- impact button,
- face,
- hand guard.

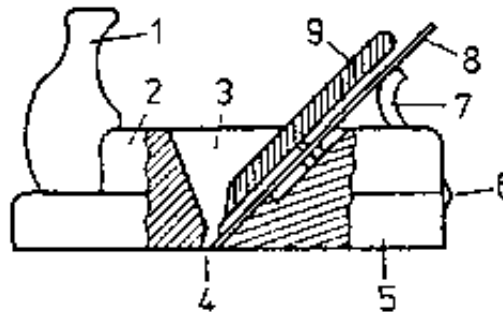

Figure 1 Parts of the plane

1 handle, 2 plane stock, 3 plane hole, 4 opening in the plane face, 5 face, 6 impact button, 7 hand guard, 8 plane iron with flap, 9 wedge

When planing, wood shavings are taken off. The plane iron is the cutting tool part. The plane iron cutting edges have a similar shape and mode of action like mortise chisel cutting edges:

- plane irons have a bevelled cutting edge at one side,

- the wedge angle at the plane iron is 25° to 30°.

The cutting effect of the plane iron cutting edge is influenced by the cutting angle. The most favourable cutting angle is between 45° and 48°. The cutting angle of a plane cannot be changed.

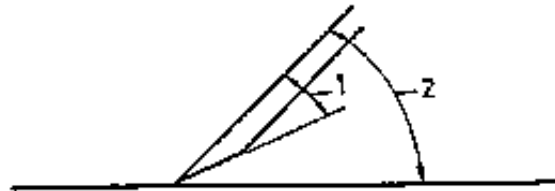

Figure 2 Wedge angle and cutting angle

1 wedge angle at the plane iron, 2 cutting angle at the plane

When planing, the cutting edge of the plane iron is pressed into the wood and splits off the shaving when the plane is advanced (pushed). The pre-splitting effect of the plane iron has to be reduced to produce a smooth surface.

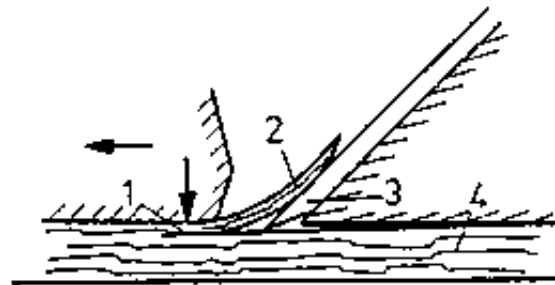

Figure 3 Mode of action of the plane iron

1 pre-splitting, 2 wood shaving, 3 plane iron cutting edge, 4 workpiece (wood)

For this purpose the plane has

- a narrow opening in the plane face to break the shaving immediately when it is lifted at the front edge of the opening,
- a flap bolted on the plane iron to additionally break the shaving at the breaking edge.

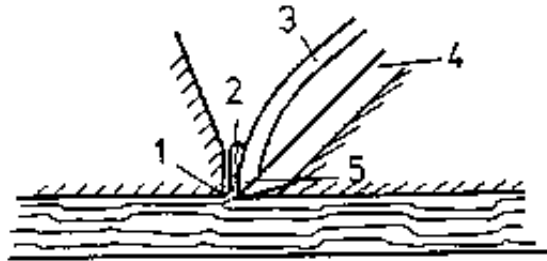

Figure 4 Breaking of the wood shaving

1 breaking edge of face opening, 2 shaving, 3 flap, 4 plane iron, 5 breaking edge at flap

The flap must

- lie closely on the plane iron,
- only be arranged max. 1 mm behind the cutting edge,
- tightly be bolted to the plane iron.

The plane stock is mainly made of hardwood, sometimes metal is also used.

Different planes are used for different requirements and working tasks, but all planes have generally the same construction. Table 1 represents the most common

planes with their characteristic features and their application.

Table 1: Types of Planes

| Designation | Features | Application |
|--------------|--|---|
| Jack plane | <ul style="list-style-type: none"> - plane length: 240 mm - plane iron width: 30 mm - no flap - cutting edge slightly rounded - wide plane opening | <ul style="list-style-type: none"> - to remove thick shavings - to coarsely plane uneven surfaces of wood |
| Finish plane | <ul style="list-style-type: none"> - plane length: 240 mm - plane iron width: 48 mm - no flap - straight cutting edge - wide plane opening | <ul style="list-style-type: none"> - to flatten surfaces of wood - to coarsely smooth surfaces |
| Double plane | <ul style="list-style-type: none"> - plane length: 220 to 240 mm - plane iron width: 48 mm - bolted flap - straight cutting edge - narrow plane opening | <ul style="list-style-type: none"> - to flatten and smooth pre-worked surfaces of wood - to provide bolts and slats with bevelled edges |
| Trying plane | <ul style="list-style-type: none"> - plane length: up to 600 mm - plane iron width: 57 mm - bolted flap - straight cutting edge - special handle | <ul style="list-style-type: none"> - to flatten large wood surfaces and narrow faces - to provide long bevelled edges |
| Rabbet plane | <ul style="list-style-type: none"> - plane length: 200 to 300 mm | <ul style="list-style-type: none"> - to provide profiles on board |

- plane iron width: 8 to 33 mm acc. to
the width of plane stock
- without or with flap

edges and narrow faces
- to finish rabbets

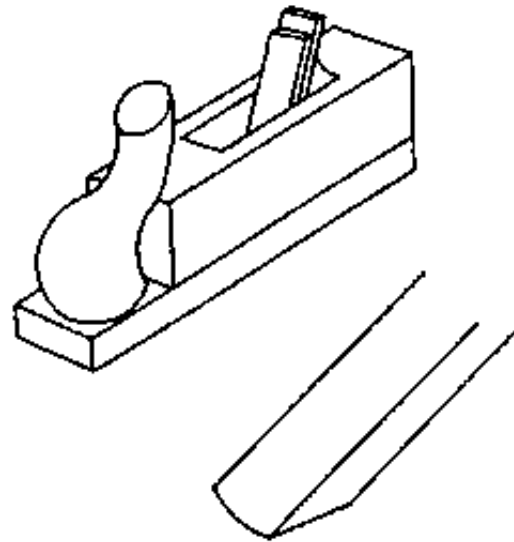

Figure 5-1 Various planes: jack plane

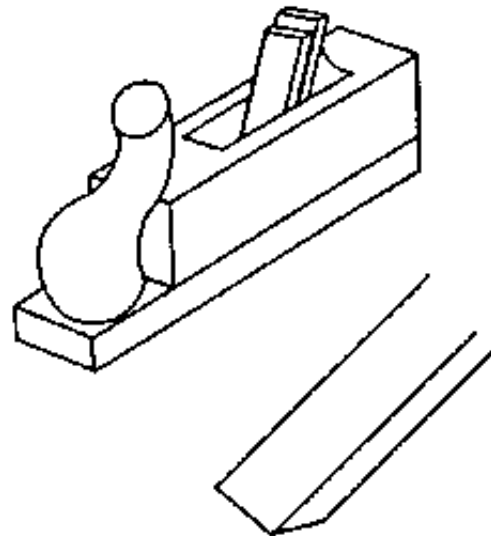

Figure 5-2 Various planes: finish plane

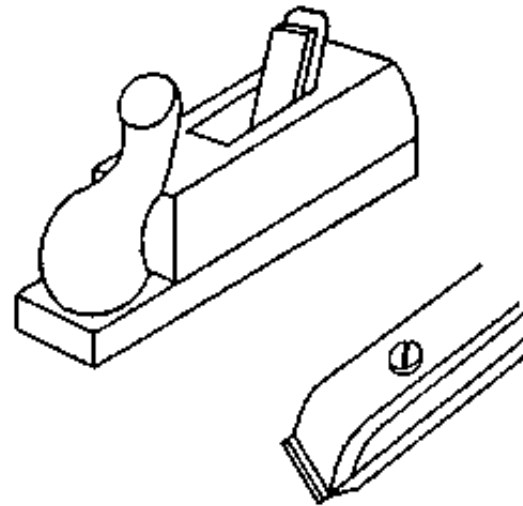

Figure 5-3 Various planes: double plane

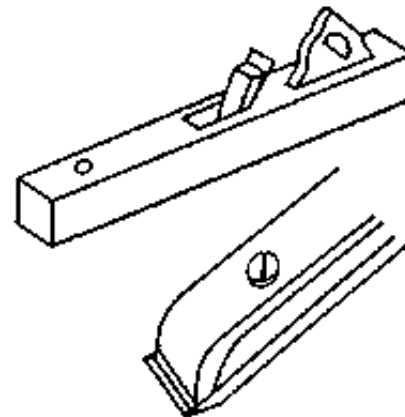

Figure 5-4 Various planes: trying plane

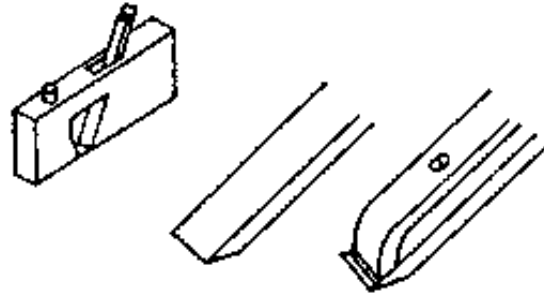

Figure 5-5 Various planes: rabbet plane

For special work, planes with

- **bent face,**
- **shaped face and appropriately shaped plane irons,**
- **special bodies and plane irons, e.g. to plane out recesses in surfaces, are used.**



[Home](#) > [ar](#).[cn](#).[de](#).[en](#).[es](#).[fr](#).[id](#).[it](#).[ph](#).[po](#).[ru](#).[sw](#)

 **Planing out - Course: Manual woodworking techniques. Trainees' handbook of lessons (Institut fr Berufliche Entwicklung, 18 p.)**

 **(*introduction...*)**

 **1. Purpose and Application of Planing**

 **2. Construction and Mode of Action of the Planes, Types of Planes**

  **3. Preparations for Planing**

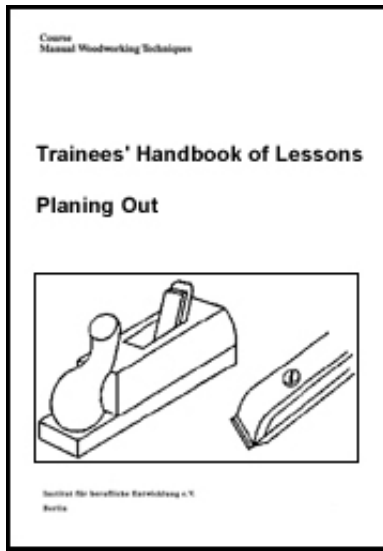

-  **4. Planing of Wide Faces**
-  **5. Planing of Narrow Faces**
-  **6. Planing of End-grained Narrow Faces (Sectional Areas)**
-  **7. Planing of Profiles**

3. Preparations for Planing

Sharpening of Plan Irons

Planes having a dull cutting edge require strenuous planing efforts and leave improper surfaces.

Dull plane irons have to be sharpened!

For sharpening of the plane iron, it is removed from the plane stock by means of blows of a hammer on the impact button.

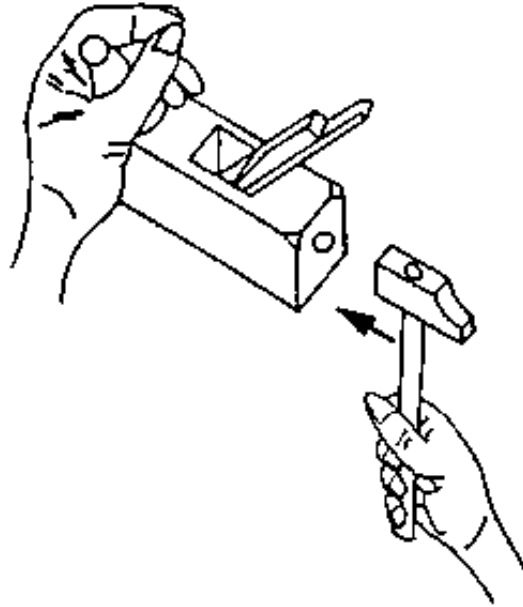

Figure 6 Removal of the plane iron from the plane stock

Double plane

It is not allowed to beat onto the cutting edge of the plane iron!

- The flap at the plane iron is loosened and removed by means of a screw driver.**

The plane iron is sharpened in two working steps:

- The plane iron is ground by means of a grinding wheel.**
 - . The plane iron cutting edge has to be kept in opposite direction to the direction of rotation wheel.**

- . In order to avoid burning out of the cutting edge, the grinding wheel is permanently moistened with water.**
- . The plane iron is clamped into a movable clamping device, if possible.**
- . The wedge angle to be adjusted in this connection at the plane iron shall be 25° to 30° .**
- . The wedge angle at the plane iron can be checked by means of a protractor.**

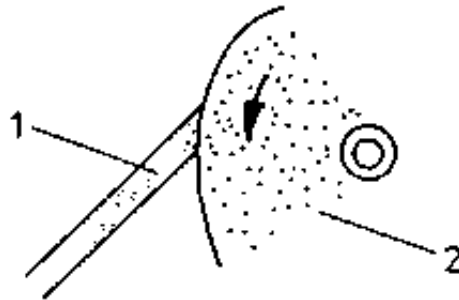

Figure 7 Grinding of the plane iron by a grinding wheel

1 plane iron cutting edge, 2 grinding wheel

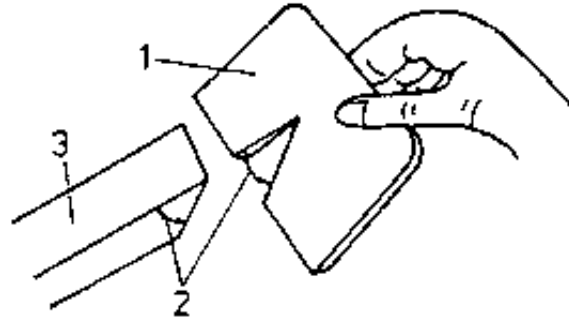

Figure 8 Checking of the wedge angle at the plane iron

1 protractor, 2 wedge angle, 3 plane iron

Task

Manufacture a reference gauge with an opening angle of 30° from a piece of plywood or similar solid material.

- Grinding of the plane iron has to be effected until the flank has uniform concaving and the cutting edge is square to the plane iron edge.

Figure 9 shows correctly and incorrectly ground cutting edges.

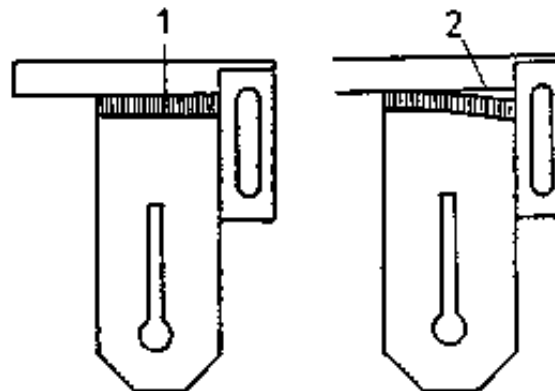

Figure 9 Square grinding of the plane iron cutting edge

1 correctly ground, 2 incorrectly ground

- Subsequently, the plane iron is stoned on a whet-stone made of natural or synthetic material and the burrs produced by grinding are removed. In order to achieve the required sharpness of the cutting edge, the following working steps have to be carried out:

- . moisten the whet-stone with oil or water;**

- . place the flank and the cutting face of the plane iron onto the stone in alternating mode and move them over the entire surface with circular moves until the burrs are taken off and the cutting edge is sharpened.**

- When stoning the plane irons of the double plane and the adjustable iron plane, the edge corners have to be slightly rounded.

- Plane irons for jack planes or planes having shaped faces are ground by means of special devices and grinding stones according to their shapes of the cutting edges.

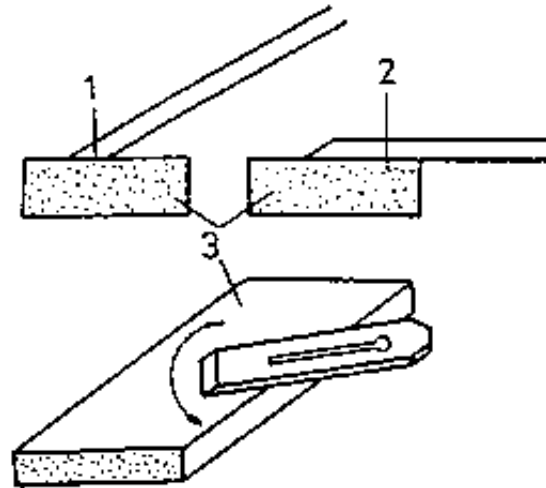

Figure 10 Stoning of the plane iron

1 flank, 2 cutting face, 3 whet-stone



Figure 11 Rounding of edge corners at the plane iron

What characteristic features must a well sharpened plane iron have?

Why is it necessary that the edge corners (between primary and secondary cutting edges) are slightly rounded?

After sharpening, the plane iron is inserted. In this connection, it has to be taken care for:

- adjusting the shaving thickness intended until the desired excess length of the plane iron at the face is achieved;**
- final wedging of the plane iron.**

The correct adjustment of the flap with its breaking edge to the plane iron cutting edge and to the breaking edge in the face opening is very important for reaching a smooth surface when planing! Exactly adjusted and sharp planes "hiss" during planing!

Maintenance of Planes

The face of a plane has to be completely flat. But after having used it for a long period, it is worn before the cutting edge to a greater extent than behind it and that is why it has to be levelled at certain intervals.

Levelling is effected as follows:

- retract and wedge the plane iron,**
- place abrasive paper onto a solid and even surface,**
- grind the face on the abrasive paper until it is flat again,**
- oil the face.**

In case of greater unevenness at the face it has to be planed by means of a plane prior to grinding. The face opening is enlarged and the distance between the breaking edges is also increased by frequent levelling of the face. In order to re-establish the right distance it is possible to insert an appropriately shaped piece of hardwood into the face. The face must be levelled, ground and oiled after the adhesive is hardened.



Figure 12 Insertion of a piece of hardwood into the plane face

1 inserted piece of hardwood, 2 face opening

Preparation of Workpieces and Workplace

Workpieces to be planed must completely be free of:

- **impurities caused by sand, coarse dust or sticking impurities of other kind;**
- **paints and paint traces soaked into the wood;**
- **nails, bolts or other metallic parts.**

The following wood is not suited to be planed:

- **Wood showing growth defects such as:**

. great knots,

- . splits,**
- . arched or wrenched grain structure;**
- organic defects such as:**
 - . insect pest,**
 - .decay,**
- too high moisture content.**

For planing, a working height of 700 mm to 800 mm is advisable. In the workshop, the workpieces are fixed into a carpenters' bench. Long workpieces are supported by a stand adjustable in height at the end which is not fixed.

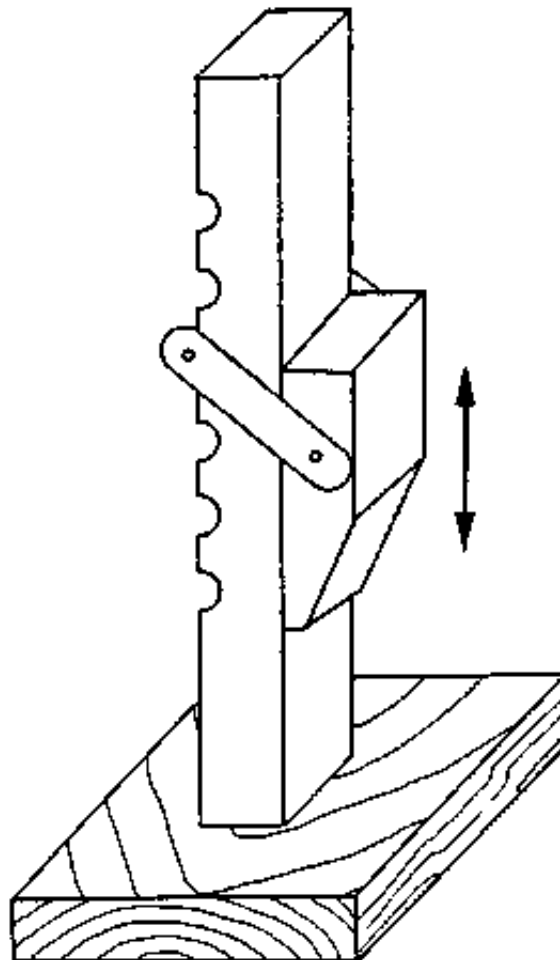

Figure 13 Adjustable workpiece stand

For site work, the trainee can manufacture a workbench by himself. It consists of:

- stand made of squared timber,**
- braces made of slats or boards,**
- plate made of boards, at least 30 mm thick.**

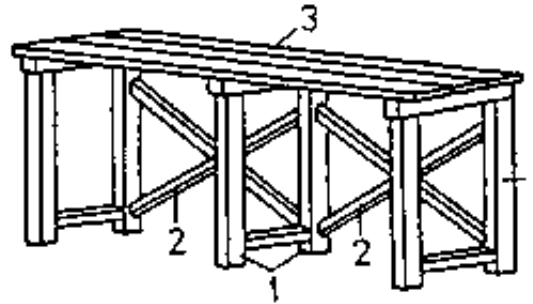

Figure 14 Site workbench

1 squared timber, 2 braces, 3 plate

A clamping board and a stop strip nailed onto the plate hold the workpiece in place in working direction and laterally when planing. The thickness of the clamping board and of the stop strip should always be smaller than the workpiece to be planed.

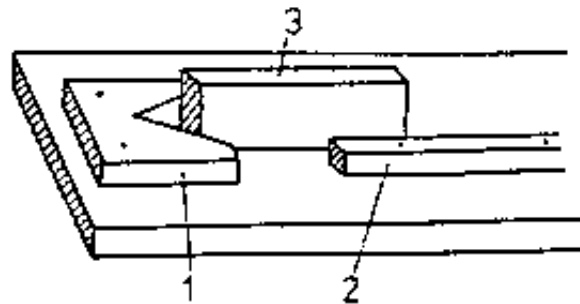

Figure 15 Clamping board to plane on sites

1 clamping board, 2 stop strip, 3 workpiece

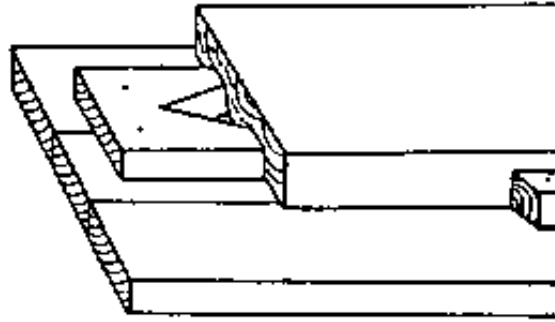

Figure 16 Clamping board and strip as stops for planing of the work-piece thickness

Working Rules for Planing

The correct working direction for planing of workpieces in longitudinal direction is always in the direction of the ascending wood grains.

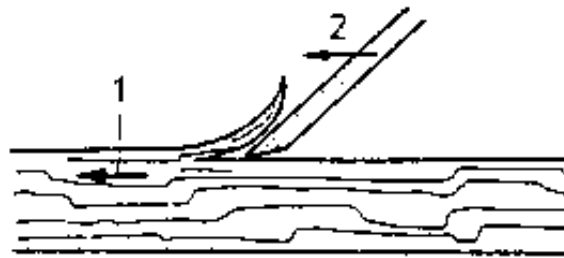

Figure 17 Correct working direction for planing

1 direction of wood grains, 2 working direction

When planing against the direction of the grains, no smooth surface can be achieved!

It is possible to plane across the direction of the grains up to an angle of 45°.

When planing narrow faces of cross-cut wood (sectional area) the plane must be moved only up to the centre of the face. The thickness of the shavings to be cut is dependent on the plane iron's excess length over the face.

The excess length is varying according to quality requirements and its adjustment must be tested:

- great excess length of the plane iron requires strenuous effort for planing and leaves uneven surfaces;**
- little excess length requires little efforts and leaves flat and smooth surfaces.**

The following rules are valid for working with planes:

- The workpiece has to be fixed or has to be secured immovably in working direction.**
- The plane iron has to be sharp and the plane must be in working order.**
- Both hands press and push against the plane:
 - . When starting pressure is applied at the front on the plane.**
 - . The face must always be placed on the wood with its entire surface.****



Figure 18 Applying the plane (starting of planing)

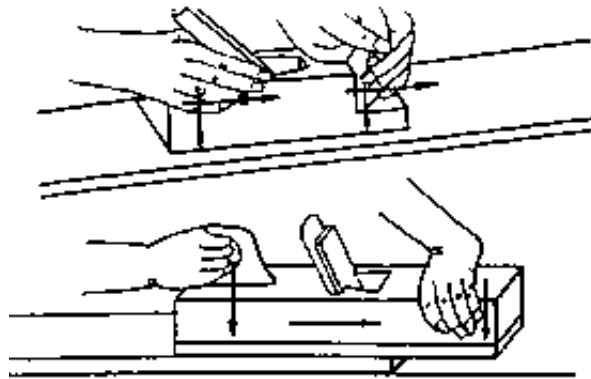

Figure 19 Moving the plane

- . When finishing, pressure is applied at the rear on the plane;
- . when returning, the plane is tilted laterally.

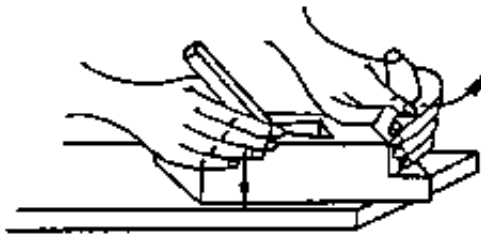

Figure 20 Taking off the plane (finishing of planing)

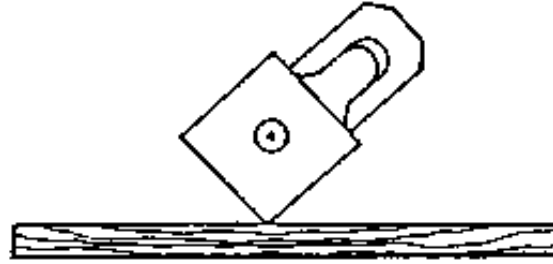

Figure 21 Returning the plane

What basic rules have to be observed when planing?

The flatness of planed surfaces is checked by:

- **Comparison of the planed surface with a straight strip (straightedge) according to the light-gap method.**
- **Sighting over two parallel strips arranged crosswise**
 - . **the surface is flat when the edges of the strips are congruent;**
 - . **the surface is not flat (inclined) when the edges are not congruent.**

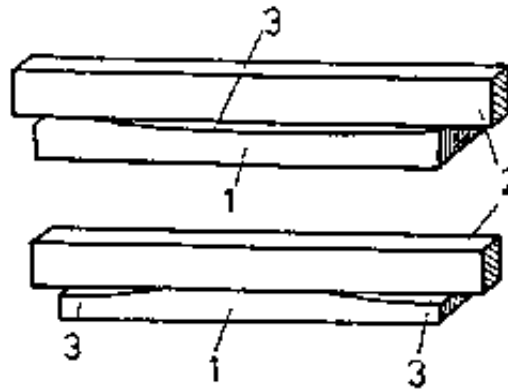

Figure 22 Checking of straightness of the workpiece

1 workpiece, 2 strip (or straightedge), 3 light gap

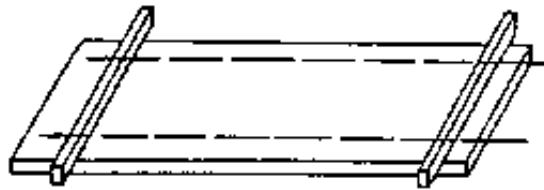

Figure 23 Checking of flatness of the surface by sighting over 2 strips

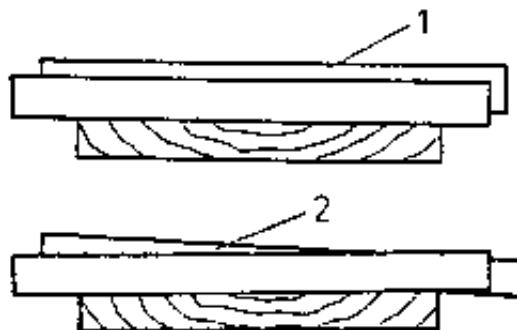

Figure 24 Checking of flatness of the surface by sighting over 2 strips

1 surface is flat, 2 surface is not flat



[Home](#) > [ar](#).[cn](#).[de](#).[en](#).[es](#).[fr](#).[id](#).[it](#).[ph](#).[po](#).[ru](#).[sw](#)



 **Planing out - Course: Manual woodworking techniques. Trainees' handbook of lessons (Institut für Berufliche Entwicklung, 18 p.)**

 **(introduction...)**

 **1. Purpose and Application of Planing**

 **2. Construction and Mode of Action of the Planes, Types of Planes**

 **3. Preparations for Planing**

  **4. Planing of Wide Faces**

 **5. Planing of Narrow Faces**

 **6. Planing of End-grained Narrow Faces (Sectional Areas)**

 **7. Planing of Profiles**

4. Planing of Wide Faces

Flattening and smoothing of larger wide faces are effected in the working steps:

- **surfacing,**
- **finishing.**

In the case of surfacing, the coarse unevenness of the cut surface is planed:

- **very uneven and rough surfaces are first planed by means of the jack plane and then by the smooth plane;**
- **surfaces being uneven and rough to a smaller extent are planed by the double plane and the adjustable iron fore plane.**

Finishing is the removal of last irregularities and smoothing of the surface by means of the double plane and the adjustable iron fore plane:

- **the plane iron must cut a thin shaving only,**
- **the planing pushes shall be effected as long as possible and**
 - . **must be placed in parallel,**
 - . **must overlap each other a little bit.**

Why is it only allowed to cut a thin shaving when finishing?

When planing a workpiece to the required thickness, then:

- **the face facing the trunk centre is planed first;**
- **the dimension of the thickness is marked out by means of a marking gauge on the narrow faces starting from the planed wide face;**
- **the opposite wide face is planed by means of the jack plane, the double plane and the adjustable iron fore plane up to the marked thickness.**

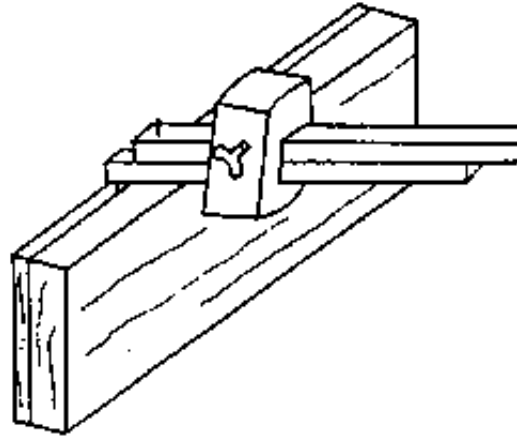

Figure 25 Marking out of the workpiece thickness by means of marking gauge



[Home](#) > [ar](#).[cn](#).[de](#).[en](#).[es](#).[fr](#).[id](#).[it](#).[ph](#).[po](#).[ru](#).[sw](#)



 **Planing out - Course: Manual woodworking techniques. Trainees' handbook of lessons (Institut für Berufliche Entwicklung, 18 p.)**

 **(introduction...)**

 **1. Purpose and Application of Planing**

 **2. Construction and Mode of Action of the Planes, Types of Planes**

 **3. Preparations for Planing**

 **4. Planing of Wide Faces**

 **➔ 5. Planing of Narrow Faces**

 **6. Planing of End-grained Narrow Faces (Sectional Areas)**

7. Planing of Profiles

5. Planing of Narrow Faces

Rectangular narrow faces are planed in the following working steps:

- **Coarse unevenness is removed by the jack plane and the smooth plane.**
- **Subsequently, the narrow face is worked by means of the trying plane,**
 - . **the trying plane is moved completely over the total length of the workpiece;**
 - . **a square, planed strip held by one hand at the face of the plane facilitates the rectangular move of the trying plane.**

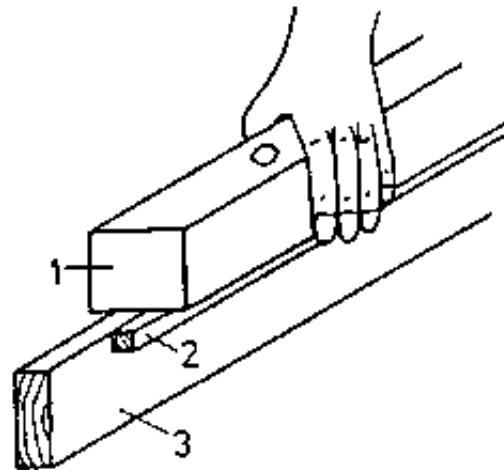

Figure 26 Handling of the trying plane for planing of narrow faces

1 trying plane, 2 held strip, 3 workpiece

Exact planing of rectangular narrow faces is checked as follows:

- Straightness by

- . applying a batten onto the narrow face;
- . joining workpieces belonging together according to the light-gap method.

- Squareness by placing a 90° steel square to the wide face.

When sighting, a hardly noticeable light gap must be visible between the square and narrow face.

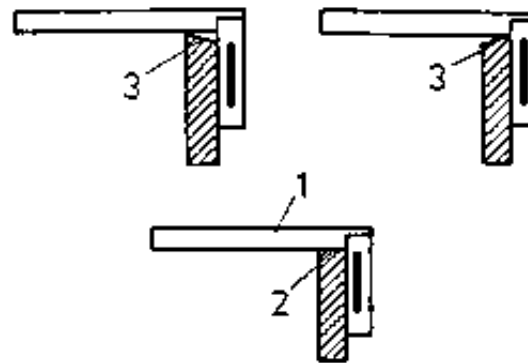
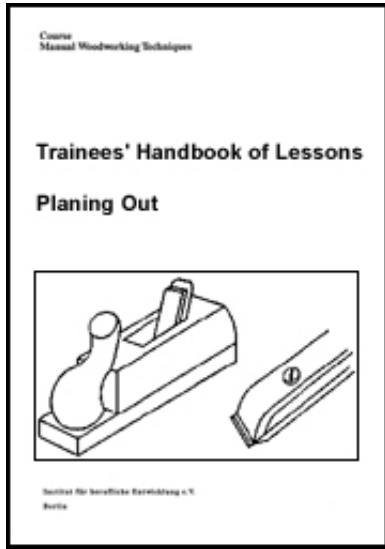

Figure 27 Checking of squareness of the wide face to the narrow face

1 back square, 2 narrow face (square), 3 light gap (not square)



[Home](#) > [ar](#).[cn](#).[de](#).[en](#).[es](#).[fr](#).[id](#).[it](#).[ph](#).[po](#).[ru](#).[sw](#)



 **Planing out - Course: Manual woodworking techniques. Trainees' handbook of lessons (Institut für Berufliche Entwicklung, 18 p.)**

 **(introduction...)**

 **1. Purpose and Application of Planing**

 **2. Construction and Mode of Action of the Planes, Types of Planes**

 **3. Preparations for Planing**

 **4. Planing of Wide Faces**

 **5. Planing of Narrow Faces**

 **➔ 6. Planing of End-grained Narrow Faces (Sectional Areas)**

 **7. Planing of Profiles**

6. Planing of End-grained Narrow Faces (Sectional Areas)

Planing of narrow faces of end-grained wood places special demands on the trainees; it is effected by means of the double plane (long narrow faces are planed by the trying plane) with:

- sharp plane iron,**
- precisely adjusted thickness of shavings.**

Rectangular narrow faces of end-grained wood are planed by short planing pushes from the two outer sides inwards.

Do not push the plane too far beyond the centre of the face otherwise the

fibres would tear out!

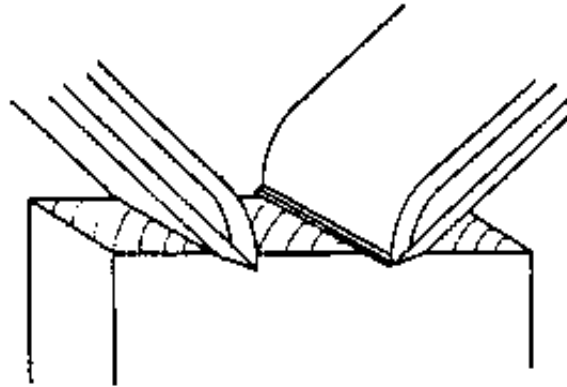

Figure 28 Working directions for planing of narrow faces of end-grained wood

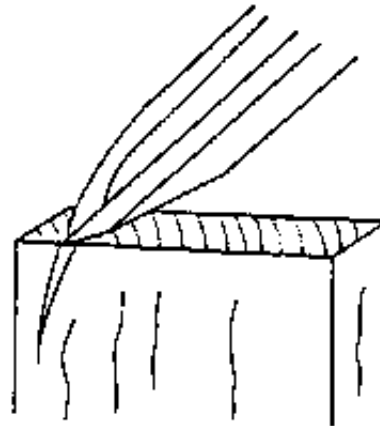

Figure 29 Tearing out of wood fibres when handling the plane incorrectly

The flatness and squareness to all sides of the narrow face are checked by:

- an applied straightedge
- a 90° steel square placed against the wide and narrow faces.

Inclined narrow cut faces are worked only in the direction of the ascending wood grain.

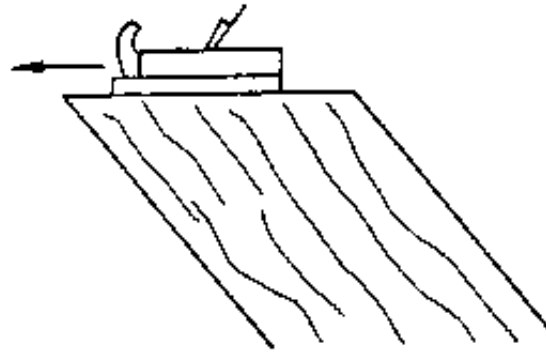
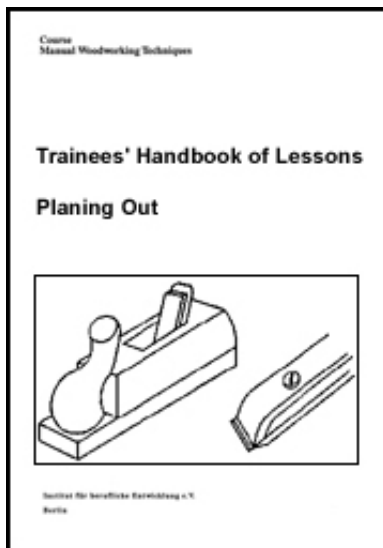

Figure 30 Working direction for planing of inclined narrow cut faces



[Home](#) > [ar](#).[cn](#).[de](#).[en](#).[es](#).[fr](#).[id](#).[it](#).[ph](#).[po](#).[ru](#).[sw](#)



 **Planing out - Course: Manual woodworking techniques. Trainees' handbook of lessons (Institut für Berufliche Entwicklung, 18 p.)**

 **(introduction...)**

 **1. Purpose and Application of Planing**

 **2. Construction and Mode of Action of the Planes, Types of Planes**

 **3. Preparations for Planing**

 **4. Planing of Wide Faces**

 **5. Planing of Narrow Faces**

-  **6. Planing of End-grained Narrow Faces (Sectional Areas)**
-   **7. Planing of Profiles**

7. Planing of Profiles

Profiles on longitudinal narrow faces and board edges are mostly pre-worked by means of special planes. Profiles, which are pre-moulded by woodworking machines, must be refitted or smoothed by special planes.

Simple chamfers on workpieces are worked by means of the double plane and the adjustable iron fore plane.

Tongues and rabbets are worked by means of the rabbet plane. If rabbets are worked manually, a straight, square strip (straightedge) must be mounted onto the workpiece as gauge for the accurate- to-size guidance of the rabbet plane.

If the workpieces are profiled across to the direction of the grains, the plane is moved in the same way as for planing of end-grained narrow faces.

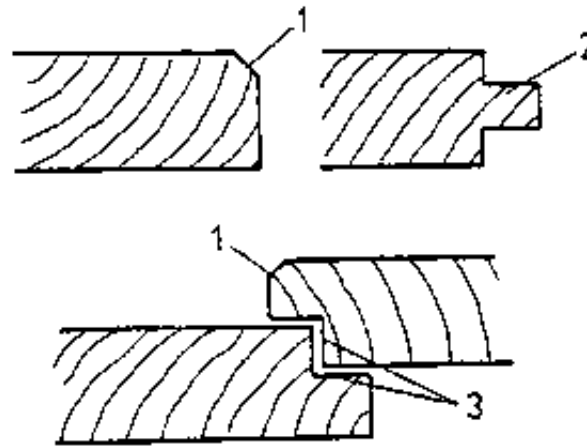

Figure 31 Profiles at narrow faces and edges

1 chamfer, 2 tongue, 3 rabet

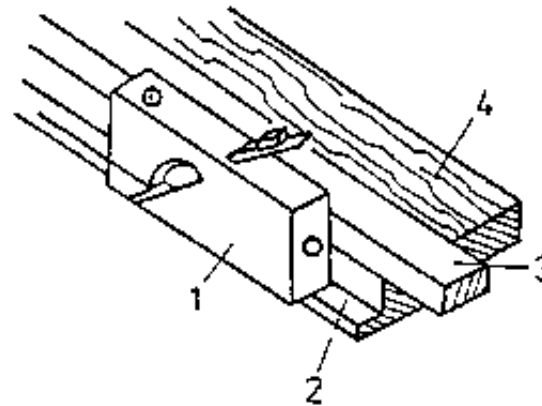

Figure 32

1 rabet plane, 2 rabet, 3 guide strip (straightedge), 4 workpiece

