

[Home](#) > [ar.cn.de.en.es.fr.id.it.ph.po.ru.sw](#)

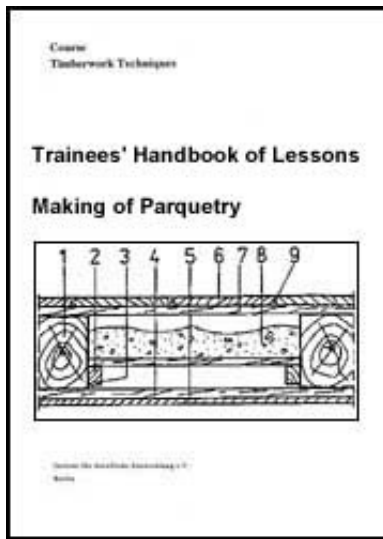

- ➔ **Making of Parquetry - Course: Timberwork techniques. Trainees' handbook of lessons (Institut für Berufliche Entwicklung, 14 p.)**
 - 📄 **(introduction...)**
 - 📄 **1. Purpose and Importance of Parquet Floor**
 - 📄 **2. Tools for Laying Parquet Floor**
 - 📄 **3. Types of Parquetry, Use of Materials and Hints on Design**
 - 📄 **4. Advice for and Rules with Making Parquet Floors**
 - 📄 **4.1. Preparation of the Subfloor**
 - 📄 **4.2. Laying of Parquet**
 - 📄 **4.3. Dressing**



[Home](#) > [ar.cn.de.en.es.fr.id.it.ph.po.ru.sw](#)

- 📖 **Making of Parquetry - Course: Timberwork techniques. Trainees' handbook of lessons (Institut für Berufliche Entwicklung, 14 p.)**
 - ➔ 📄 **(introduction...)**
 - 📄 **1. Purpose and Importance of Parquet Floor**
 - 📄 **2. Tools for Laying Parquet Floor**

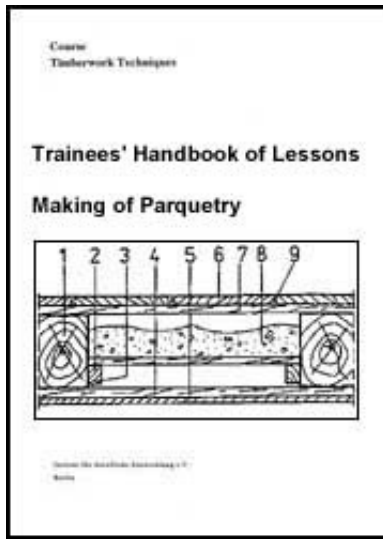

- 3. Types of Parquetry, Use of Materials and Hints on Design
- 4. Advice for and Rules with Making Parquet Floors

**Institut für berufliche Entwicklung e.V.
Berlin**

**Original title:
Arbeitsmaterial für den Lernenden
"Herstellen von Parketts"**

Author: Peter Wehrmann

First Edition © IBE

**Institut für berufliche Entwicklung e.V.
Parkstraße 21/23
13187 Berlin**

Order No.: 93-35-3607/2





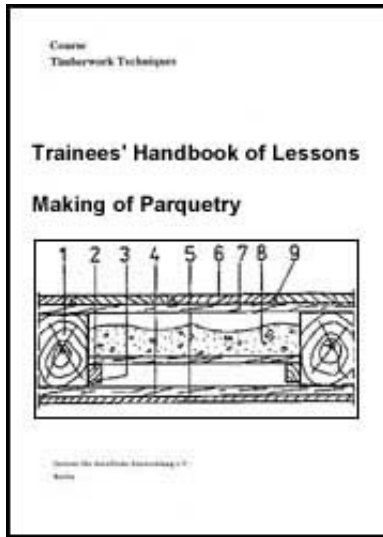

[Home](#) > [ar](#).[cn](#).[de](#).[en](#).[es](#).[fr](#).[id](#).[it](#).[ph](#).[po](#).[ru](#).[sw](#)



Making of Parquetry - Course: Timberwork techniques. Trainees' handbook of lessons (Institut fr Berufliche Entwicklung, 14 p.)

 *(introduction...)*

-   **1. Purpose and Importance of Parquet Floor**
-  **2. Tools for Laying Parquet Floor**
-  **3. Types of Parquetry, Use of Materials and Hints on Design**
-  **4. Advice for and Rules with Making Parquet Floors**

1. Purpose and Importance of Parquet Floor

Parquetry belongs to the category of floor covering, like, for instance, planed boarding, plastic coverings, fleximer flooring and ceramic flooring.

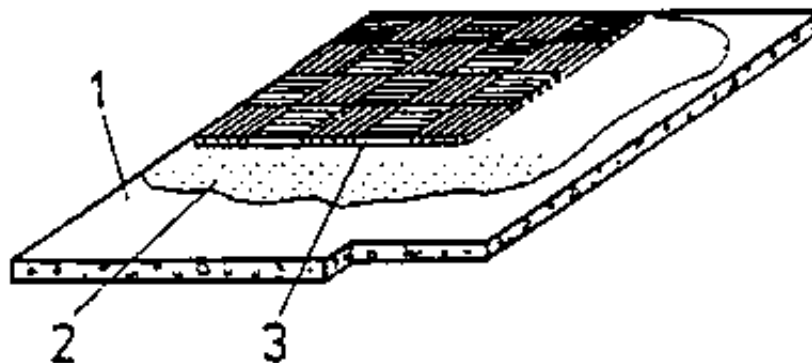

Figure 1

Parquetry

1 subfloor, 2 adhesive bed, 3 mosaic fillet

It is the immediately utilized layer of the floor. The selection of the flooring to be laid is determined by the various demands the future use of the floor will make. The most important requirements on floorings and the qualities of parquetry are mentioned below:

Technical demands

(Compressive and flexural strength as well as wear resistance)

In this respect, parquetry shows the best properties and greatest resistance to wear. Its service life, for example in a living-room, hotel room or office lasts for more than 60 years.

Physical demands as to construction engineering

(Thermal and sound insulation, protection against moisture)

Here, too, parquetry proves to be the best possible solution, with its properties, as a rule, being far better than those of any other types of flooring, except moisture protection.

Technological demands

(Time of manufacture, time of drying, period of time till the floor can be used)

Here the properties of parquetry are unfavourable. Parquet laying requires a complicated sequence of operations:

It must be prepared on special machines, and the laying and entire trimming of it again requires much time. Another and rather long period must pass till the floor can be used. This waiting period is longer than with other types of flooring.

Economic demands

(Parquetry is the most expensive flooring as to material and manufacture)

The wood used for this purpose must meet great requirements with respect to strength and aesthetical qualities.

Premanufacture as well as laying require much time and labour.

Demands on design

(Appearance, total aesthetical effect on the design of the room)

Here, parquetry meets highest standards. By suitable patterns and selected kinds of wood, parquet floor can have an excellent effect on the design and atmosphere of a room.

Fields of application of parquetry

Parquetry may be used in housing and social construction as well as in industrial

building, for instance in

- **gymnasia**
- **restaurants**
- **arts centres**
- **flats**
- **production rooms in light industry, etc.**

What are the essential qualities of parquet floor?

How long does the service life of a parquet floor last with normal utilization?



[Home](#) > [ar](#).[cn](#).[de](#).[en](#).[es](#).[fr](#).[id](#).[it](#).[ph](#).[po](#).[ru](#).[sw](#)

 **Making of Parquetry - Course: Timberwork techniques. Trainees' handbook of lessons (Institut fr Berufliche Entwicklung, 14 p.)**

 **(introduction...)**

 **1. Purpose and Importance of Parquet Floor**

 **2. Tools for Laying Parquet Floor**



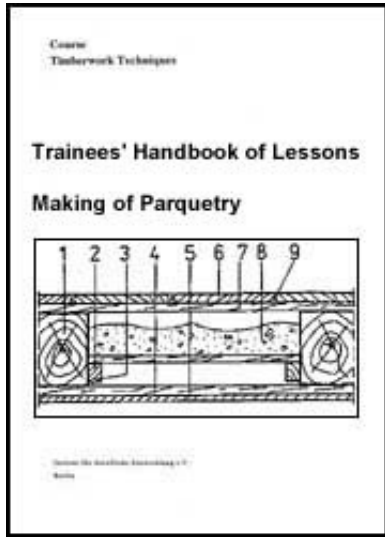

3. Types of Parquetry, Use of Materials and Hints on Design



4. Advice for and Rules with Making Parquet Floors

2. Tools for Laying Parquet Floor

The below mentioned tools relate to the laying of premanufactured parquetry only.

The making of parquetry-fillets, elements, etc. requires special wood processing machines.

The following working means are required for laying different kinds of parquet floors:

Measuring, marking and testing instruments

- Folding rule, pencil
- Flat and try squares
- Pipe-level
- Water-level

- String

Tools for parquet laying

- Hand saws**
- Hammers**
- Nail tongs**
- Plane**
- Nail punch**
- Mallet**
- Abrasive paper**
- Files**
- Tow hooks**

Tools for preparing the subfloor, as well as for applying the adhesive and the sealer coat

- Broom**
- Putty knife (pushing) Putty knife (drawing)**
- Brush**
- Paint roller**

Other equipment

- Grinding machine**
- Cans and buckets for adhesive and sealer coat storage and processing**
- Carpenter's bench**
- Protective clothing (knee protection)**



[Home](#) > [ar](#).[cn](#).[de](#).[en](#).[es](#).[fr](#).[id](#).[it](#).[ph](#).[po](#).[ru](#).[sw](#)

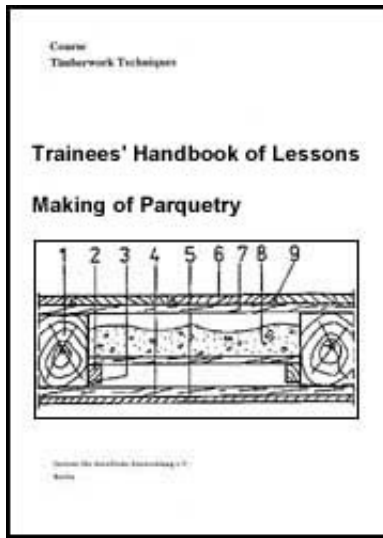

 **Making of Parquetry - Course: Timberwork techniques. Trainees' handbook of lessons (Institut fr Berufliche Entwicklung, 14 p.)**

 **(introduction...)**

 **1. Purpose and Importance of Parquet Floor**

 **2. Tools for Laying Parquet Floor**

 **3. Types of Parquetry, Use of Materials and Hints on Design**

 **4. Advice for and Rules with Making Parquet Floors**

3. Types of Parquetry, Use of Materials and Hints on Design

The types of parquetry are categorized as follows:

Parquet floor

It consists of parquetry-fillets. The parquetry-fillets are pieces of wood made from raw slats, rectangular, with key and slot and with plane-parallel top and bottom surfaces.

The minimum thickness is 16 mm.

It is distinguished between:

Parquetry-fillet with fixed key

Parquetry-fillet having a key at two of its narrow surfaces and a slot in the other two narrow surfaces.

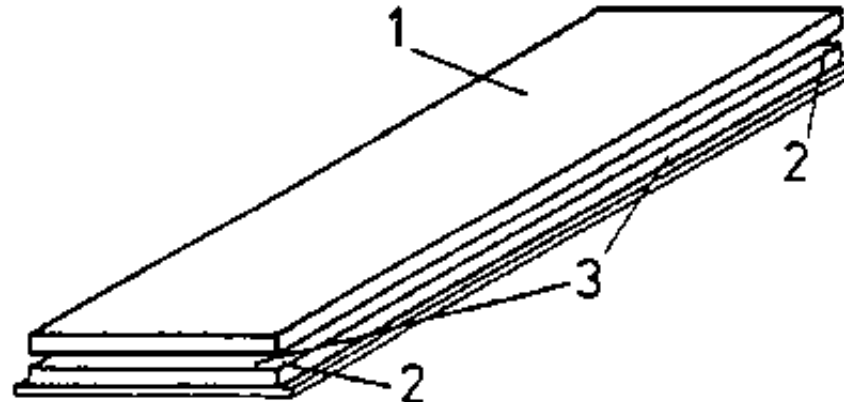

Figure 2

Parquetry-fillet with fixed tongue

1 wear layer, 2 groove, 3 tongue

Parquetry-fillet with loose key

Parquetry-fillet in which a slot is cut in all its narrow surfaces to receive loose keys.

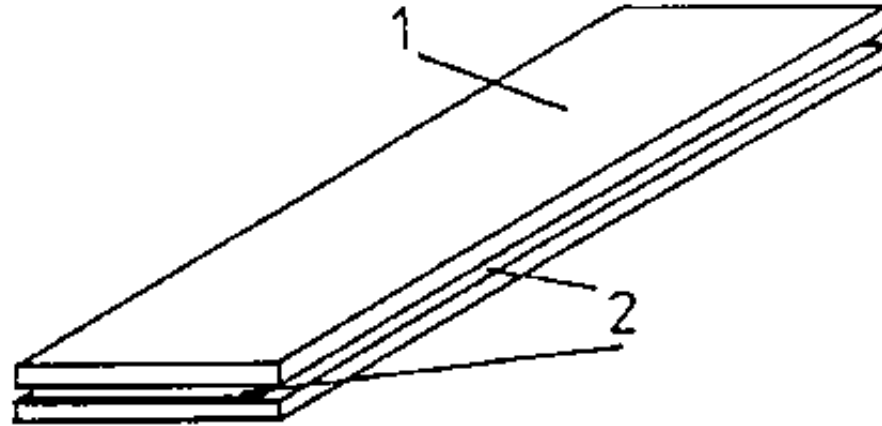

Figure 3

Parquetry-fillet with loose tongue

1 wear layer, 2 groove

Parquetry elements

Premanufactured wood element, large and mostly self-supporting, consisting of several layers which are glued to one another, and showing profiled narrow surfaces.

It is distinguished between:

Parquet board

Element of parquetry of a rectangular shape the third layer of which mostly consists of mosaic parquetry.

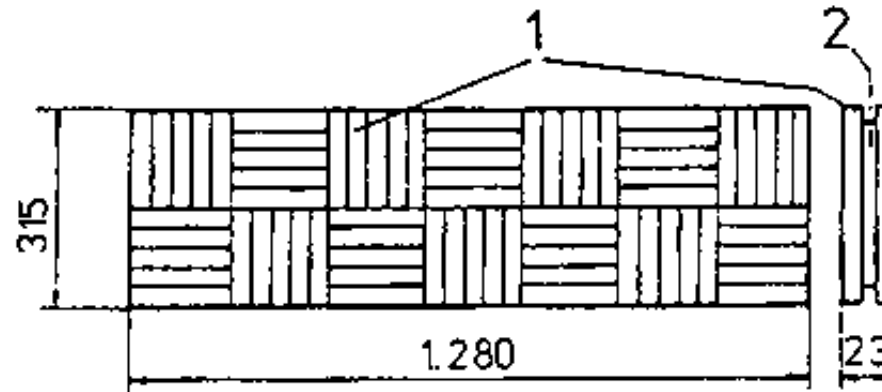

Figure 4

Parquet deal

1 wear layer from mosaic fillets, 2 groove

Parquet panel

Element of parquetry of a square shape, the third layer of which mostly consists of mosaic parquetry.

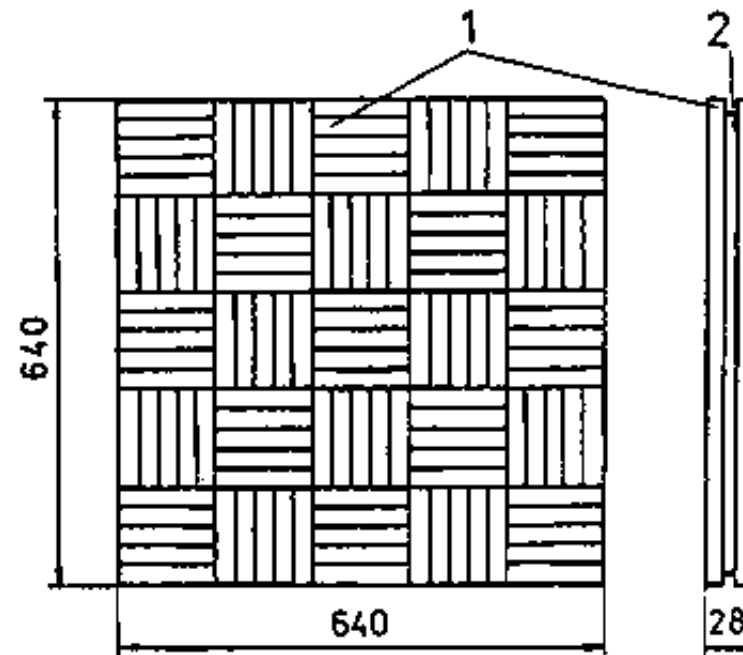

Figure 5

Parquet panel

1 wear layer from mosaic fillets, 2 groove

Mosaic parquetry

A part of parquetry made from mosaic parquetry-fillets of one or several kinds of wood and laid according to a pattern. Mosaic parquetry is mostly premanufactured in the form of parquetry elements but it may also be composed of single pieces.

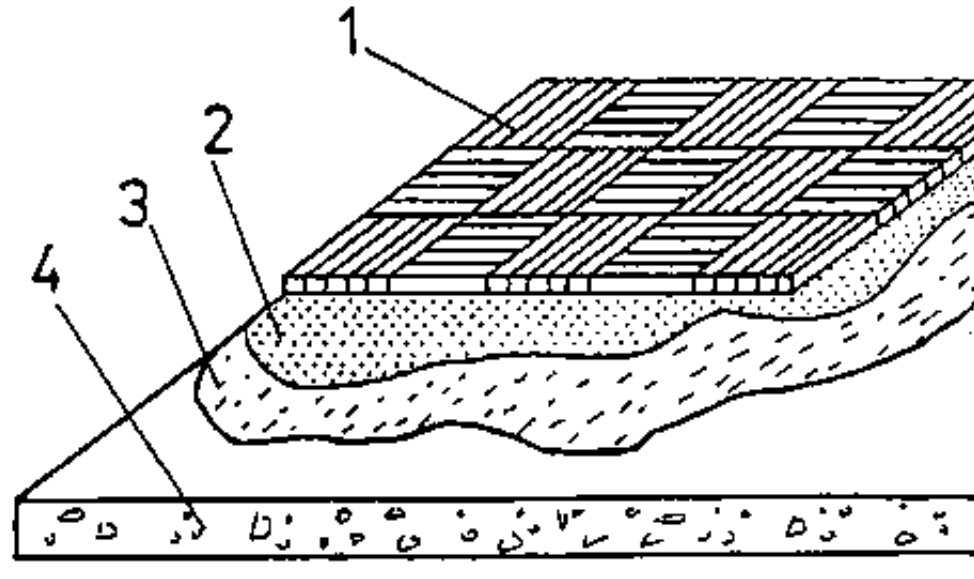

Figure 6

Mosaic fillet parquetry

1 mosaic fillet, 2 adhesive, 3 precoat, 4 solid subfloor

What types of parquetry are there?

The kinds of wood used for the above mentioned parts of parquetry must be hard, must have no knots or off-colours, no 'bark bags', no infestation, only very few capillary cracks and absolutely no working faults.

Parquetry is the aesthetically most effective flooring. Therefore, great importance has to be attached to its design.

This depends mainly on the size of the room as well as on its future use.

This holds good for the size of the individual parts of parquetry as well as for its design.

Kinds of parquetry patterns in use are:

Herring-bone pattern

The laying is very complicated and time-consuming. A frieze strip must be laid along the edges for calming.

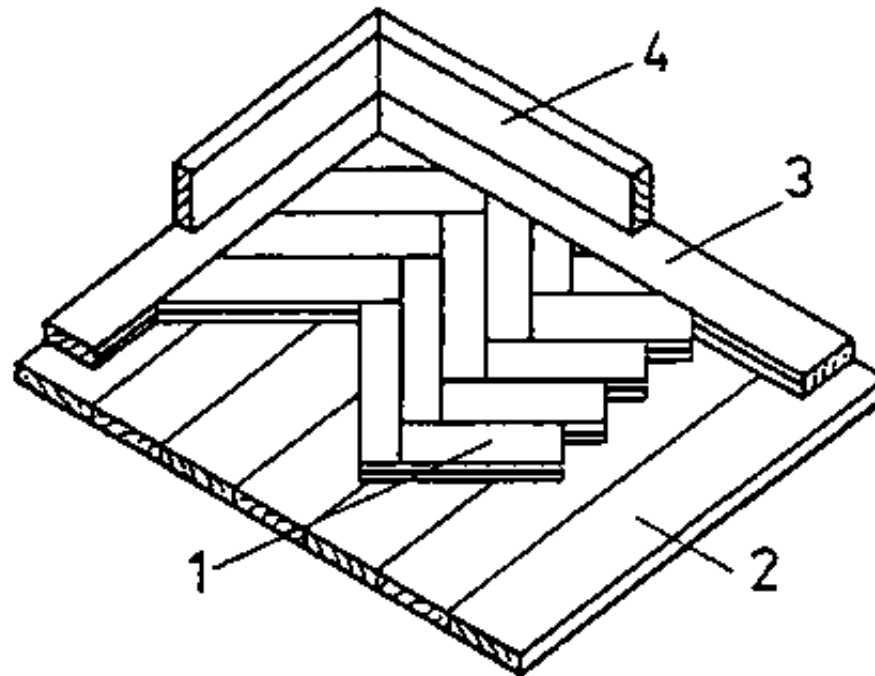

Figure 7

Parquetry - herring-bone pattern

1 parquetry-fillet, 2 planed boarding, 3 frieze strip, 4 skirting board***Belt or ship's bottom pattern***

Laying is easier. The pattern can be continued right to under the skirting board.

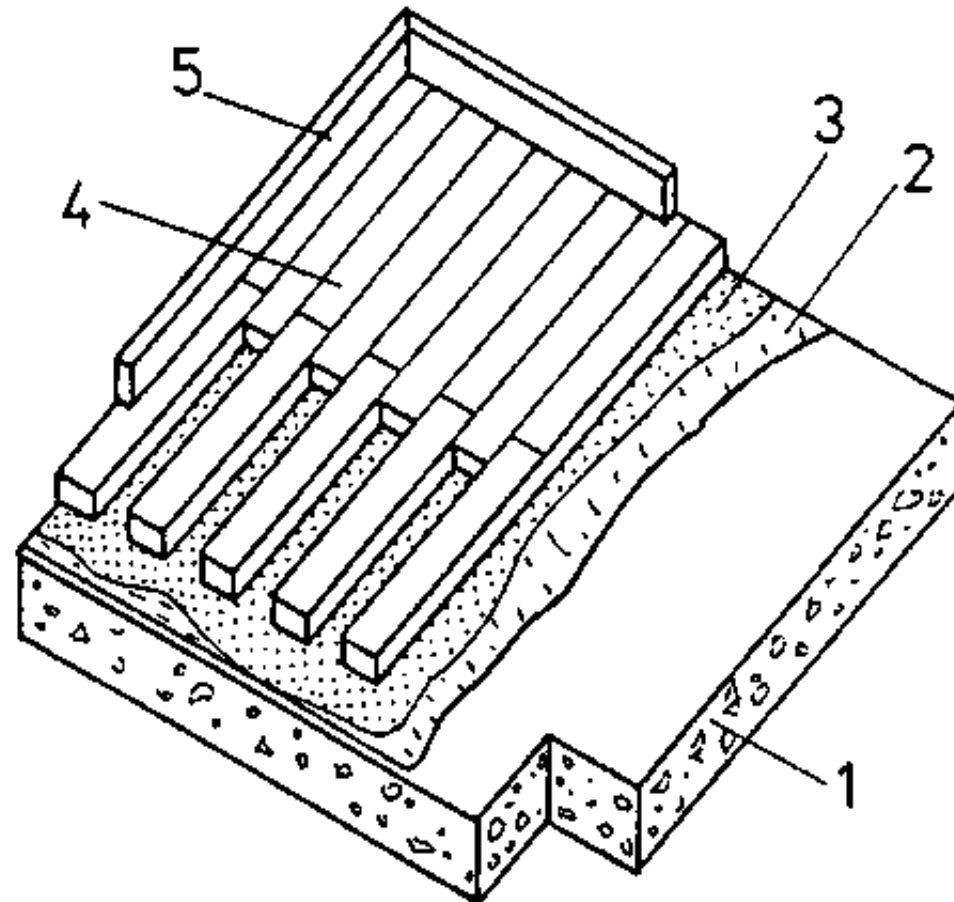

Figure 8

Parquetry - belt or ship's bottom pattern

1 solid subfloor, 2 precoating/adhesive, 3 bituminous felt/adhesive, 4 parquets-fillets, 5 skirting board

For the top layers of parquetry elements mainly mosaic pattern and combined forms - mosaic fillets and wood panels - are used.

The following should be considered with the organization of a parquet-covered surface:

- The entire surface must keep its uniform appearance.**
- Accentuations in one direction may cause optical illusions. They should therefore be applied carefully.**
- Illusory spatial effects as caused by certain arrangements of shapes and distribution of brightness have to be avoided.**
- Individual forms organizing the surface must be in harmonic correspondence with the size of the total surface.**

Belt or ship's bottom pattern appears as balanced due to its uniform surface, though it is animated by the structure of the wood.

With the herring-bone pattern the direction and counter-direction of the individual pieces almost neutralize each other. The frieze strip running along the border creates a harmonious transition to the skirting board and the wall surface.



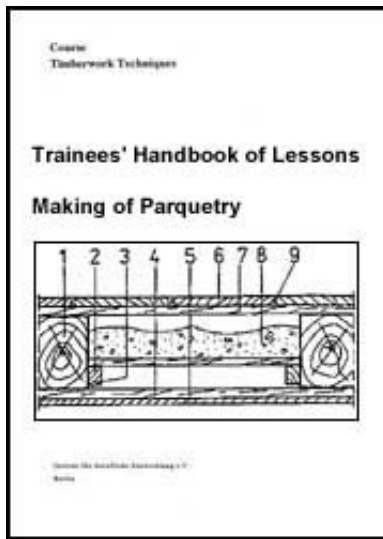

 **Making of Parquetry - Course: Timberwork techniques. Trainees' handbook of lessons (Institut fr Berufliche Entwicklung, 14 p.)**

  **4. Advice for and Rules with Making Parquet Floors**

 **4.1. Preparation of the Subfloor**

 **4.2. Laying of Parquet**

 **4.3. Dressing**

Making of Parquetry - Course: Timberwork techniques. Trainees' handbook of lessons (Institut fr Berufliche Entwicklung, 14 p.)

4. Advice for and Rules with Making Parquet Floors

4.1. Preparation of the Subfloor

Subfloors are made in the following forms:

- **Timber beam floor**
- **Solid floor**
- **Solid floor with rooms without basement**

In the case of a timber beam floor, the following has to be done:

- **The inherent stability of the boards is checked. If necessary, they are renailed, replaced or turned.**
- **The timber is checked for pest infestation and, if required, single pieces are replaced.**
- **If the boarding floor is no longer able to support load, the boards are taken off and replaced by a 24 mm thick layer of blind boards which are nailed on the timber beams.**
- **If the 'new' floor level must not be higher than the 'old' one, the boards are inserted between the timber beams and fixed to laterally screwed-on laths.**

No spiral-grained wood or wood with falling-off knots must be used for the laths. Wooden floors must not be covered with bituminous or tar-saturated felt. The parquet layer can be nailed on the prepared surface.

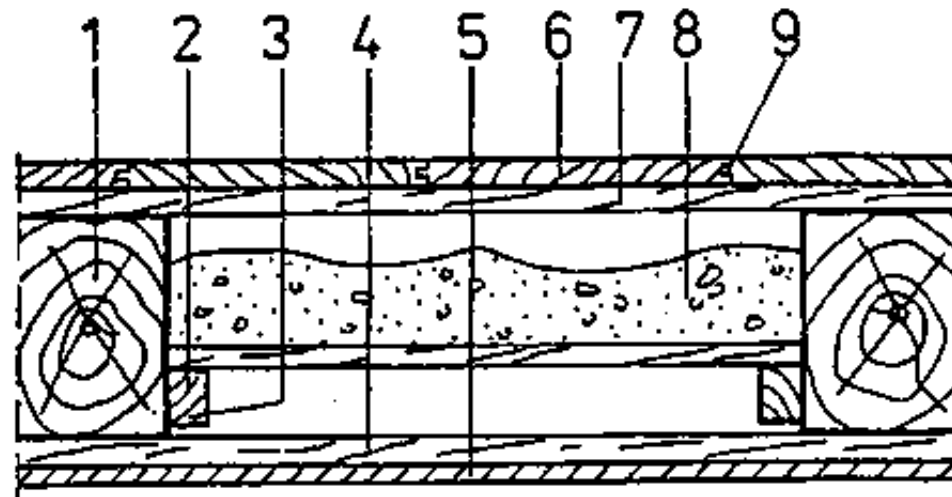

Figure 9

Parquetry elements on planed boarding

1 floor beam, 2 inserted timber, 3 laths, 4 timbering, 5 lathwork/plaster, 6 parquet deals, 7 planed boarding, 8 filler, 9 tongue

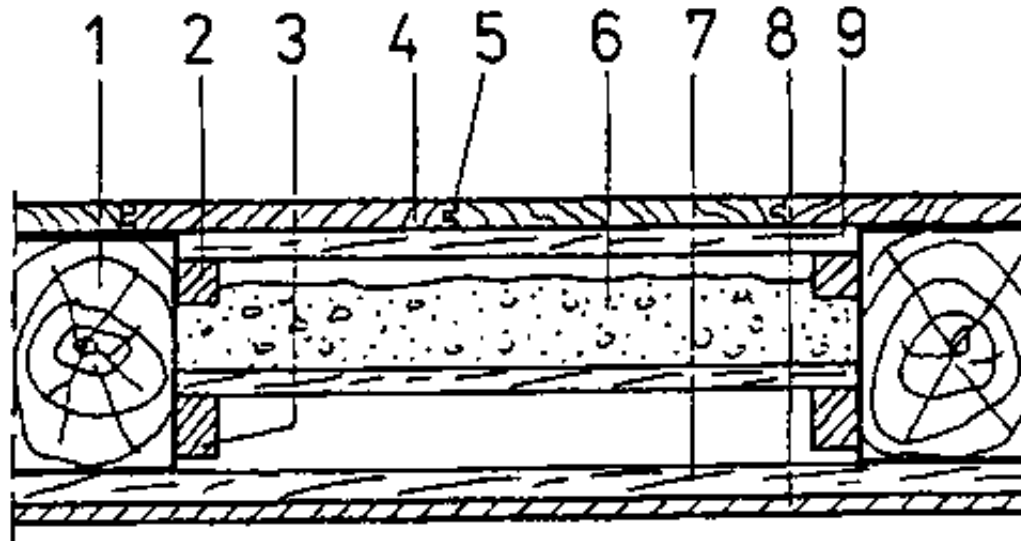

Figure 10

Parquetry elements on planed boarding laid on a lower level between the beams

1 beam, 2 supporting laths. 3 laths, 4 parquet deals, 5 tongue, 6 filler, 7 timbering, 8 lathwork/plaster, 9 planed boarding fitted between the beams

With solid ceilings and solid floors, respectively, the following sequence of operations is to be adhered to:

- Shall the parquetry be laid on a solid floor, make sure that there is a proper thermally insulating and moisture-proofing layer. If required, it has to be supplied additionally.**

- First of all, the solid ceiling or floor, respectively, is carefully cleaned. In doing so, all loose parts are removed.**

- The solid ceiling or floor must not release any sand or show any kind of greater unevennesses in its surface. Possibly it must be repaired or reworked.**

- When using parquetry-fillets and/or parquetry elements, a layer of bare bituminous felt, pasted edge to edge, must be laid under the parquetry. Attention! - not with mosaic parquetry!**

- Another technique is the laying of supporting beams, if height is no problem. These supporting beams can be covered with a false floor.**

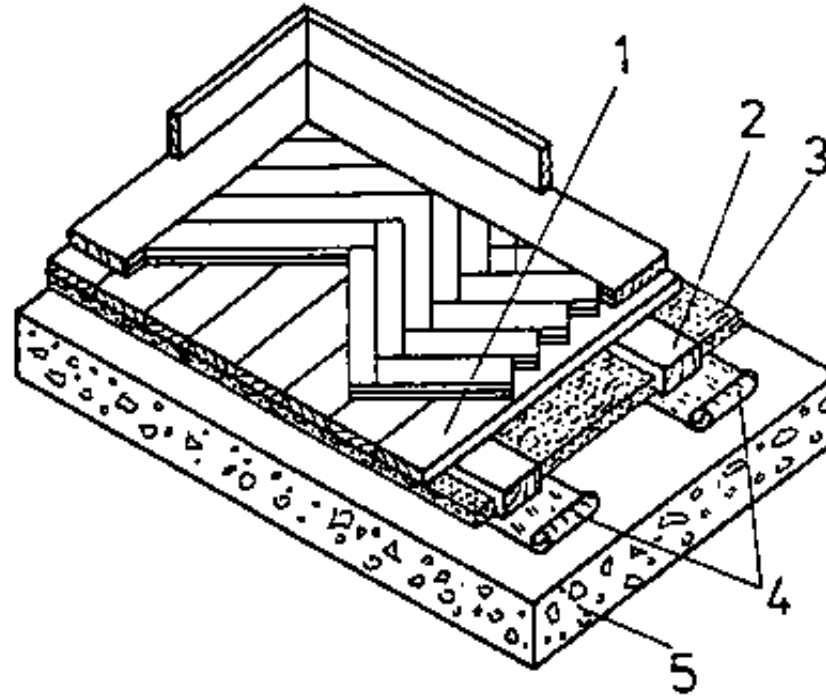

Figure 11

Parquetry-fillets with false floor and beam layer on solid subfloor

1 false floor, 2 beam layer, 3 insulating material, 4 bituminous felt strips, 5 solid substructure

In this case, an essential improvement in thermal insulation and sound proofing can be achieved. With this kind of subfloor, parquetry is nailed.

What kinds of subfloors are in use?

When is tar-saturated or bituminous felt laid as the immediate base of parquetry?

How can the insulation properties of a solid floor be improved in connection with parquet laying?

4.2. Laying of Parquet

Parquet can be nailed or pasted.

Fillets of mosaic parquetry are always pasted due to their small dimensions.

The most commonly used dimensions of mosaic parquetry-fillets, as well as parquetry-fillets are given in the below survey:

Survey 1: Current dimensions of mosaic parquetry-fillets and parquetry-fillets

Mosaic parquetry-fillets

	Thickness	Width	Length
Tolerances (mm)	± 0.3	-	± 0.1
Dimensions (mm)	8	20...	120
		27	130
			150
			160

Parquetry-fillets

	Thickness	Width	Length	
Tolerances (mm)	± 0.4	± 0.5 %	± 0.2	
			Short fillet	Long fillet
Dimensions (mm)	16,18	40,50	200	600
	20,22	60,70	250	700
		80,90	300	800
		100	350	1000
			400	
			450	
			500	

Adhesive for laying parquetry

This is a bituminous solution or other suitable product which is typical of the respective country. Its properties must be elastic and plastic ones. As precoating, diluted adhesive is used.

Nails for laying parquetry

For this purpose, the below mentioned nails are to be used preferably:

- With 22 mm thick parquet floor - 45 mm or 50 mm long countersunk head nails.**

- **With thinner parquet floor - 40 mm long countersunk head nails.**
- **With parquet elements - 50 mm long countersunk head nails.**

Before parquetry is laid, all the other constructional and interior work must be completed.

The room temperature with parquet laying must be at least 15 centigrade, and the relative air humidity must be between 45 and 65 %.

Laying of parquetry-fillets on wooden floors

After the careful cleaning of the wooden subfloor, the parquetry-fillets are laid - not parallel to the longitudinal direction of the boards of the false floor or of the deals. The parquetry-fillets are fixed by covered nailing through the narrow surface. With 200 - 400 mm long fillets use one nail, and with 400 - 500 mm long fillets use two nails. Connections with other kinds of floor covering are made with the help of metal strips as splicing pieces.

Laying parquetry-fillets on solid subfloors

After careful cleaning parquetry adhesive is spread with a drawing scraper over the entire surface of the subfloor.

On this a layer of bare bituminous felt - butt-joined - is pasted - not with mosaic parquetry.

On this layer parquetry adhesive is spread in such way that the parquetry-fillets lie in the bed of adhesive by at least 2/3 of their base surfaces.

With parquetry-fillets designed for loose keys the cross-grain keys have to be distributed evenly over at least 50 % of the entire length of the slots.

Laying of parquetry-fillets on supporting beams with or without false floor

The process is the same as with laying parquetry-fillets on wooden floors, vis. Fig. 11.

Laying of mosaic parquet

After careful cleaning of the solid subfloor a precoating of thinned adhesive is made.

Then the parquet adhesive is spread over the subfloor and the mosaic parquet is pressed firmly into the adhesive film.

How can parquetry be connected with the surface under it?

How must parquetry-fillets be nailed on?

4.3. Dressing

After the parquetry has been laid and the adhesive has aged, which takes at least two days, the floor is mechanically ground and sealed three times afterwards. After each sealing a technical waiting time of 24 hours has to be kept.

Sealers:

The sealer fills the pores of the floor, forms a well-adherent and wear-resistant film which protects the parquet against wear and moisture.

-The following sealers are used for parquet floors:

- Oil and synthetic resin sealers**
- Acid-hardening sealers**
- Sealers consisting of several components**
 - Polyurethane sealers**
 - Epoxide resin sealers**
- Combination cellulose nitrate sealers**

The sealers show various properties. Therefore, their specific use depends on the future purpose. Greatest hardness is achieved by multicomponent sealers.

Parquetry work has to be integrated in the entire building process in such way that no bricklaying or installation work must be done after the parquetry has been laid.

As a rule, parquetry should be laid even after painting.

How long is the technological waiting period after sealing?

Why should parquetry be laid always at the end of all building work?

What kinds of sealers are there?

Which sealers give the greatest hardness?

How is parquetry finished?

