











- ➔ **Stairmaking - Course: Timberwork techniques. Instruction examples for practical vocational training (Institut für Berufliche Entwicklung, 34 p.)**
- 📄 **(introduction...)**
 - 📄 **Preliminary Remarks**
 - 📄 **Instruction Example 8.1.: Taking off Dimensions at the Stairwell**
 - 📄 **Instruction Example 8.2.: Determination for the Ratio of Rise and Tread**
 - 📄 **Instruction Example 8.3.: Scribing of landing connections**
 - 📄 **Instruction Example 8.4.: Manufacture of Template and Angular Board**
 - 📄 **Instruction Example 8.5.: Scribing and Preparing the Stair Strings**
 - 📄 **Instruction Example 8.6.: Manufacture of Steps and Risers**
 - 📄 **Instruction Example 8.7.: Assembly of the Stair Flight**



Stairmaking - Course: Timberwork techniques. Instruction examples for practical vocational training (Institut für Berufliche Entwicklung, 34 p.)



- ➔  **(introduction...)**
-  **Preliminary Remarks**
-  **Instruction Example 8.1.: Taking off Dimensions at the Stairwell**
-  **Instruction Example 8.2.: Determination for the Ratio of Rise and Tread**
-  **Instruction Example 8.3.: Scribing of landing connections**
-  **Instruction Example 8.4.: Manufacture of Template and Angular Board**
-  **Instruction Example 8.5.: Scribing and Preparing the Stair Strings**
-  **Instruction Example 8.6.: Manufacture of Steps and Risers**
-  **Instruction Example 8.7.: Assembly of the Stair Flight**

**Institut für berufliche Entwicklung e.V.
Berlin**

Original title:

**Lehrbeispiele für die berufspraktische Ausbildung
"Herstellen von Treppen"**

Author: Rolf Becher

First Edition © IBE











Institut für berufliche Entwicklung e.V.
Parkstrae 21/23
0-1100 Berlin

Order No.: 93-33-3608/2



[Home](#) > [ar](#).[cn](#).[de](#).[en](#).[es](#).[fr](#).[id](#).[it](#).[ph](#).[po](#).[ru](#).[sw](#)



-  **Stairmaking - Course: Timberwork techniques. Instruction examples for practical vocational training (Institut für Berufliche Entwicklung, 34 p.)**
-  **(introduction...)**
-   **Preliminary Remarks**
-  **Instruction Example 8.1.: Taking off Dimensions at the Stairwell**
-  **Instruction Example 8.2.: Determination for the Ratio of Rise and Tread**
-  **Instruction Example 8.3.: Scribing of landing connections**
-  **Instruction Example 8.4.: Manufacture of Template and Angular Board**
-  **Instruction Example 8.5.: Scribing and Preparing the Stair Strings**
-  **Instruction Example 8.6.: Manufacture of Steps and**



Risers Instruction Example 8.7.: Assembly of the Stair Flight

Preliminary Remarks

The present booklet contains 7 selected instruction examples to practise and consolidate knowledge and skills in the manufacture of straight mortised wooden stairs with two branches of flights.

The instruction examples have been selected so that the individual exercises can be practised separately or successively, one based on the previous one.











The hand tools, measuring and testing tools and auxiliary accessories as well as the previous knowledge required are stated for each instruction example. The previous knowledge is necessary in addition to knowledge of the "stairmaking" technique and should be recapitulated at the beginning. The sequence of operations specified for each example gives the order of working steps leading to the manufacture of the respective stair components or calculations.

A working drawing showing the required shapes and dimensions of the stair components and auxiliary accessories is attached to each example. The necessary explanations to the working drawing are given prior to the description of the sequence of operations.

For acquiring and practising the skills to be developed it is recommended to manufacture the stair components in the workshop in the scale 1: 2.5.





-  **Stairmaking - Course: Timberwork techniques. Instruction examples for practical vocational training (Institut für Berufliche Entwicklung, 34 p.)**
-  **(introduction...)**
-  **Preliminary Remarks**
-  **Instruction Example 8.1.: Taking off Dimensions at the Stairwell**
-  **Instruction Example 8.2.: Determination for the Ratio of Rise and Tread**
-  **Instruction Example 8.3.: Scribing of landing connections**
-  **Instruction Example 8.4.: Manufacture of Template and Angular Board**
-  **Instruction Example 8.5.: Scribing and Preparing the Stair Strings**
-  **Instruction Example 8.6.: Manufacture of Steps and Risers**
-  **Instruction Example 8.7.: Assembly of the Stair Flight**

Instruction Example 8.1.: Taking off Dimensions at the Stairwell

A stairwell for straight mortised stairs two opposed branches of flights (180 degrees' turn) and with landing is to be measured in order to compare the dimensions with the drawing.

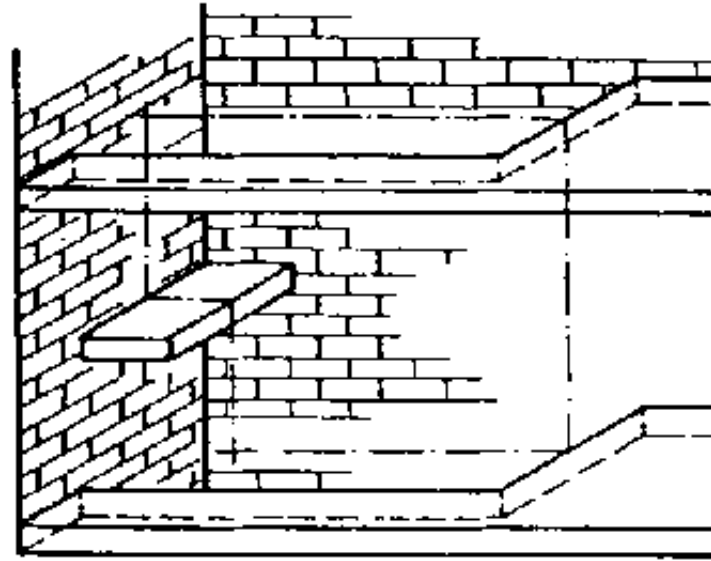

Figure

Hand tools

Hammer, hand saw

Measuring and testing means

Folding rule, water level, hanging plumb, straightedge, builder's square

Auxiliary accessories

Pencil, battens to transfer the sizes

Necessary previous knowledge

Reading of drawings, measuring, plumbing, levelling, aligning, scribing

Explanations to the working drawing

In stairmaking, it is never the stairwell that is shown in a drawing but always the stairs to be built into it.

Sequence of operations	Comments
1. Draw a hand-sketch.	Draw the dimensions lines only. Draw the plan view and sectional view.
2. Put the builder's square on the upper ceiling at the opening intended for the stairs to be built in and check for squareness.	Apply the longer leg at the stair range. If necessary, determine the right angle and note down in the sketch.
3. Measure a gauge size on the straightedge and scribe-mark.	Use a size corresponding to the decimetric system, such as 1.0m, 1.1 m, 1.20 m etc. Write the gauge size into the hand-sketch.
4. Wind up the plumb cord and fix it to the straightedge at the scribed marks.	Cord must have a sufficient length to extend until the surface of the half-landing.
5. Put the straightedge on the surface of the	

main top landing in the	
<p>area of the wall string. 6. Support the straightedge by a batten to be held perpendicularly and move the straightedge towards the half-landing.</p>	<p>Saw a notch into the upper end of the batten or nail a projecting bearing block onto either wide side of the batten so that the straightedge will not slip off the cross-grained end of the supporting batten. Hold the batten perpendicularly and move it carefully together with the straightedge. Make sure that the straightedge is not released, otherwise danger of accidents! The plumb cord must not contact the front edge of the half-landing.</p>
<p>7. Put the water level on the straightedge and level it.</p>	<p>Check the water level for accuracy first.</p>
<p>8. Put the perpendicular batten to the half-landing and scribe-mark the surface of the landing.</p>	<p>Identify the scribed mark with index "W" so that mix-up will be avoided when entering the dimensions into the hand-sketch!</p>
<p>9. Scribe the front edge of the main top landing on the straightedge.</p>	<p>Don't forget index "W"!</p>
<p>10. Wait until the pendulum movement of the hanging plumb stopped and measure the difference between the plumb cord and</p>	<p>Add up the gauge size scribed on the straightedge and the difference and enter into the plan view of the hand-sketch as flight length.</p>

front edge of the half-landing.

11. Move the supported straightedge towards the outer string and repeat WORKING STEPS 7. to 10. above in the area of the outer string!

Identify scribed marks on straightedge and batten with index "F"!

12. Retract straightedge with supporting batten towards main landing.

Make sure that the straightedge is not tilted or released!

13. Measure the scribed sizes on the batten and enter into hand-sketch.

Mind indexes "W" and "F"! Write into the sectional view as flight height between half-landing and main top landing.

14. Take a longer batten and put it to the front edges of the two main landings. Scribe-mark the surfaces of the landings.

Hold the batten perpendicularly! Apply the batten in the areas of the wall string and outer string.

15. Remove the batten and measure the size

Write into sectional view as floor-to-floor height.

between the scribed marks, write into hand-sketch.	
16. Check the landings for horizontal position.	Write any deviations into hand-sketch with "+" or "-".
17. Check the stairwell width, contact the wall with the batten and scribe inner edge.	Write stairwell width into hand-sketch.
18. Find out the stair flight length and stairwell width from the hand-sketch.	Base on determined angle.
19. Compare the dimensions taken off the stairwell with those in the drawing.	Stairs are to be built to the dimensions of the stairwell!

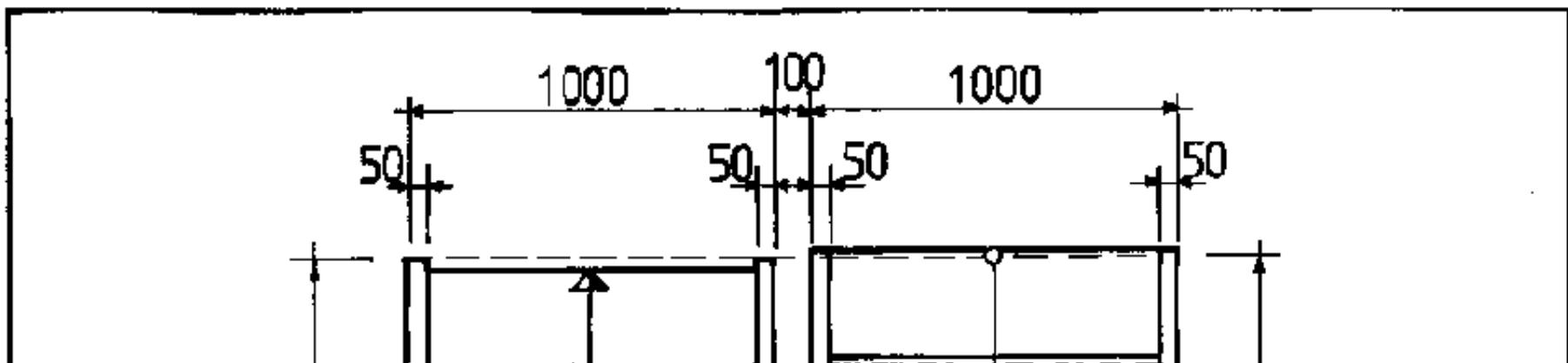

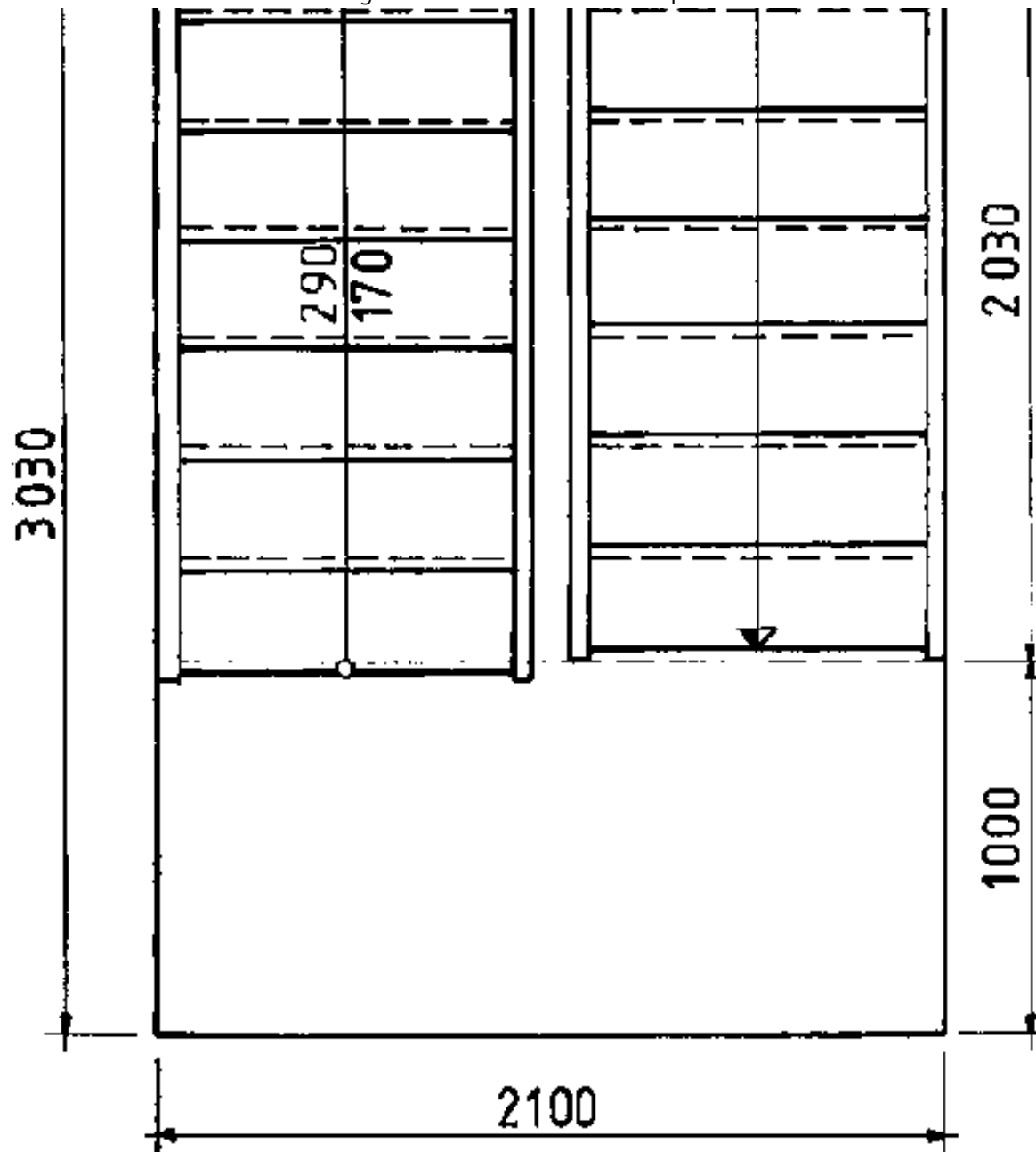

			8.1
IBE	Taking off Dimensions at the Stairwell		3608

Taking off Dimensions at the Stairwell



[Home](#) > [ar](#).[cn](#).[de](#).[en](#).[es](#).[fr](#).[id](#).[it](#).[ph](#).[po](#).[ru](#).[sw](#)

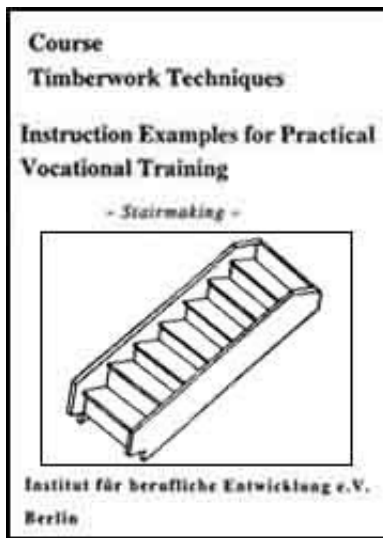

- Stairmaking - Course: Timberwork techniques. Instruction examples for practical vocational training (Institut für Berufliche Entwicklung, 34 p.)**
 - (introduction...)**
 - Preliminary Remarks**
 - Instruction Example 8.1.: Taking off Dimensions at the Stairwell**
 - Instruction Example 8.2.: Determination for the Ratio of Rise and Tread**
 - Instruction Example 8.3.: Scribing of landing connections**
 - Instruction Example 8.4.: Manufacture of Template and Angular Board**
 - Instruction Example 8.5.: Scribing and Preparing the Stair Strings**



Instruction Example 8.6.: Manufacture of Steps and Risers



Instruction Example 8.7.: Assembly of the Stair Flight

Instruction Example 8.2.: Determination for the Ratio of Rise and Tread

The dimensions given below have been taken off the stairwell and entered into the hand-sketch.

Details of the stairs to be built in:

- straight stairs with two branches of flights, mortised**
- string thickness: 50 mm**
- riser thickness: 15 mm**
- floor thickness main landing: 24 mm**

-

$$m = \frac{290}{170}, ns = 8$$

Auxiliary accessories

Paper, pencil, slide rule or calculator/computer

Necessary previous knowledge

Fundamental arithmetics: adding, subtracting, dividing, multiplying

Explanations to the working drawing

(1) main top landing

(2) main bottom landing

(3) half-landing

(4) upper edge of bare ceiling

Sequence of operations	Comments
1. Sequence stair height for one branch of flights.	Divide the measured floor-to-floor height by two.
$Lh = \frac{2736 \text{ mm}}{2} \quad Lh = 1368 \text{ mm}$	
2. Determine the height of rise.	
$s = \frac{Lh}{n_s} \quad s = \frac{1368 \text{ mm}}{8} \quad s = 171 \text{ mm}$	
3. Check the flight	Start from the size $n_s \bullet a = L$ and compare with the size at the

length.	stairwell (2090 mm).
$L = n_a \cdot a$ $L = 7 \cdot 290 \text{ mm}$ $L = 2030 \text{ mm}$	The difference of 60 mm is to be compensated at the top landing connection!
<p>4. Check the half-landing height.</p> $Gh + d_1 - d_2 = Lh!$ $1410 \text{ mm} + 24 \text{ mm} - 40 \text{ mm} =$ $1394 \text{ mm} \neq 1368 \text{ mm}$	<p>Check from the main top landing.</p> $Lh = 1368 \text{ mm}!$ Half-landing is to be raised!
<p>5. Find out the difference.</p> $1394 \text{ mm} - 1368 \text{ mm} = 26 \text{ mm}$	Half-landing is to be raised by 26 mm. Half-landing is not removed but 26 mm thick boards are put on before the floor is constructed!

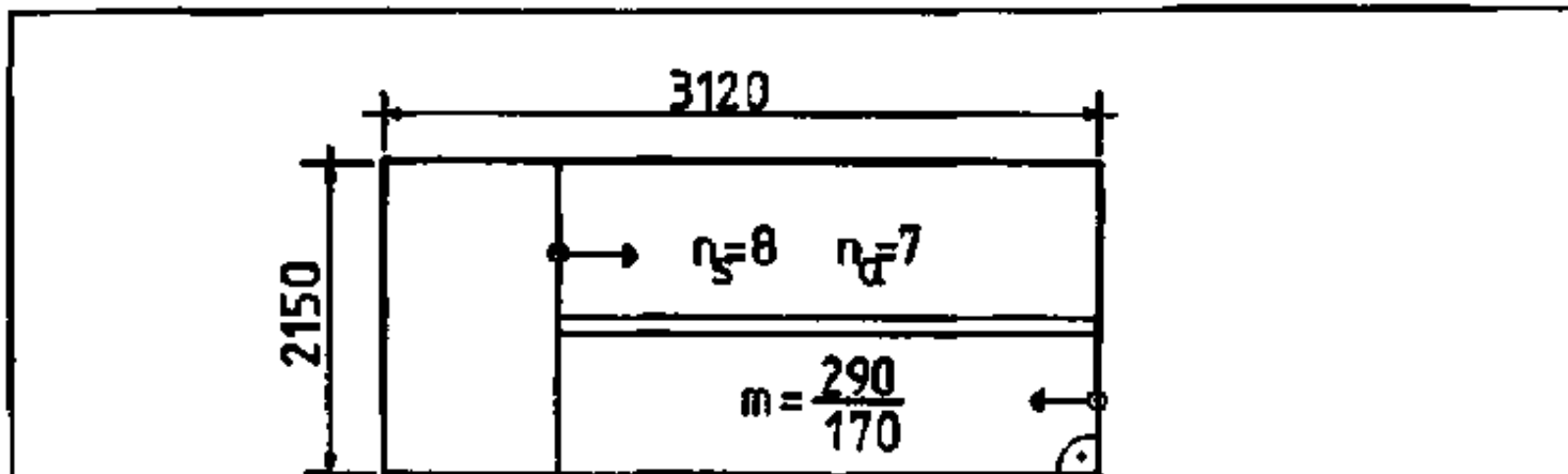

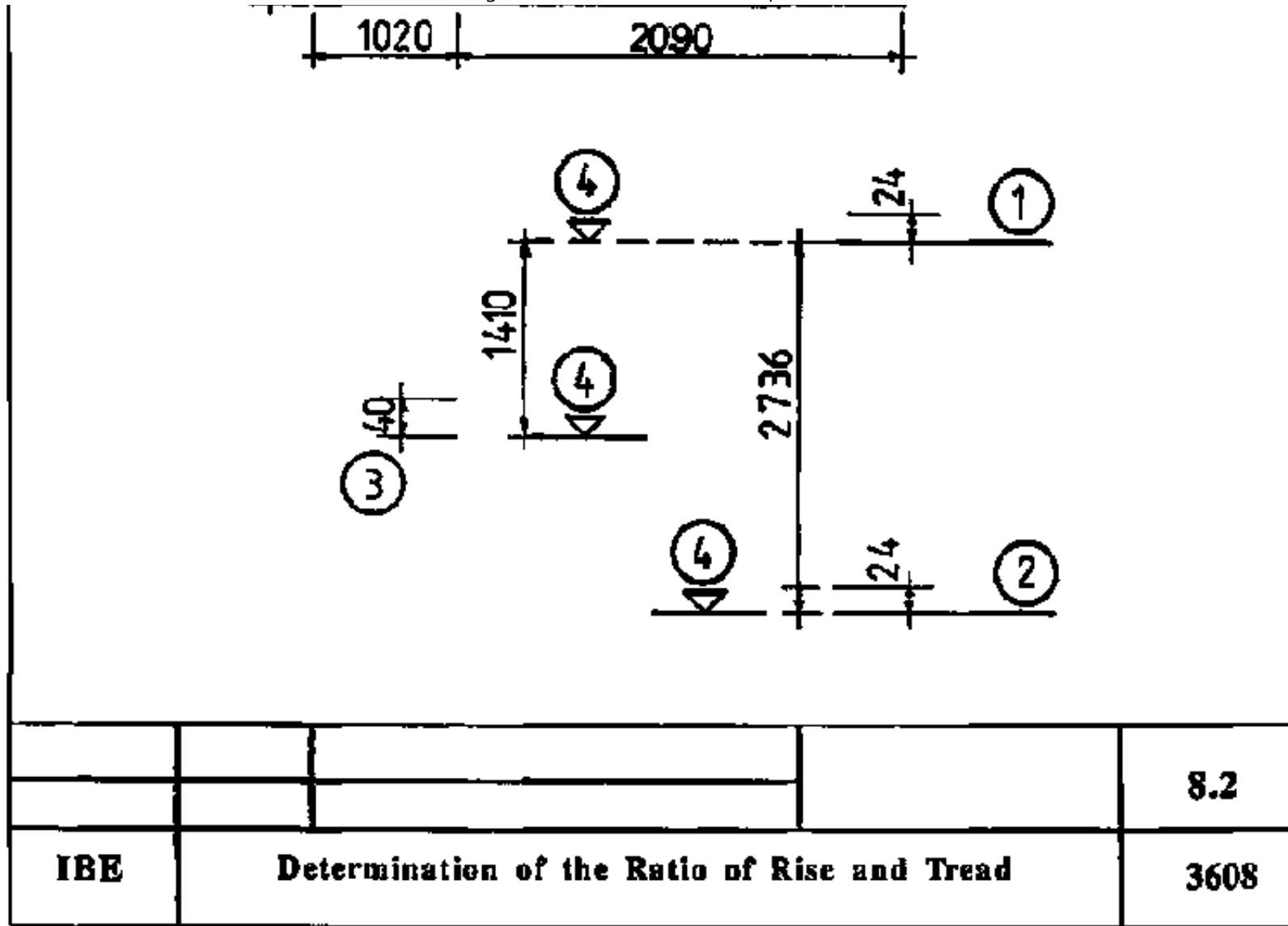

Determination of the Ratio of Rise and Tread



[Home](#) > [ar](#) [cn](#) [de](#) [en](#) [es](#) [fr](#) [id](#) [it](#) [ph](#) [po](#) [ru](#) [sw](#)



Stairmaking - Course: Timberwork techniques. Instruction examples for practical vocational training (Institut für Berufliche Entwicklung, 34 p.)

 **(introduction...)**

 **Preliminary Remarks**

 **Instruction Example 8.1.: Taking off Dimensions at the Stairwell**

 **Instruction Example 8.2.: Determination for the Ratio of Rise and Tread**

 **➔ Instruction Example 8.3.: Scribing of landing connections**

 **Instruction Example 8.4.: Manufacture of Template and Angular Board**

 **Instruction Example 8.5.: Scribing and Preparing the Stair Strings**

 **Instruction Example 8.6.: Manufacture of Steps and Risers**

 **Instruction Example 8.7.: Assembly of the Stair Flight**

Instruction Example 8.3.: Scribing of landing connections

Details assumed to be known:

Stairwell length without landing: 2200 mm

Stairwell height = stair flight height: 1620 mm

Ratio of rise and tread $m = \frac{270}{180}$

Number of rises $n_s = 9$

Step thickness: 35 mm

Riser thickness: 15 mm

False tread: 30 mm

Floor thickness $d_1 = d_2 = 24$ mm

Cross-section of stair-aprons = 140/180 mm²

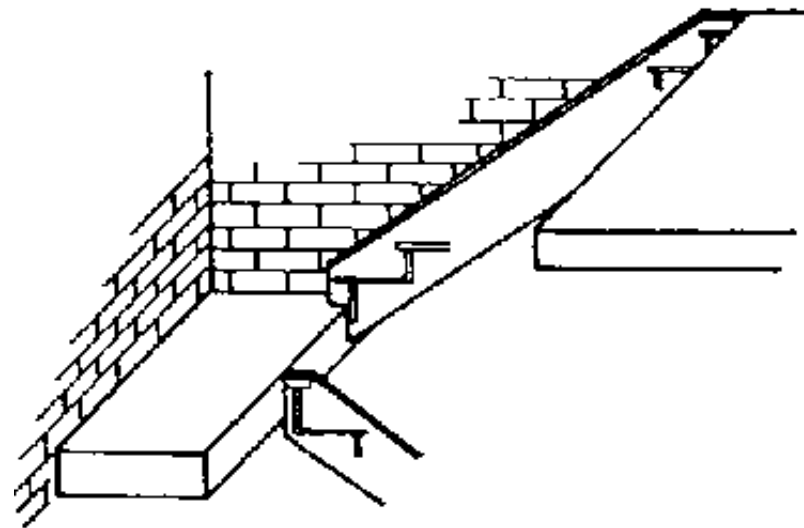

Figure

Measuring and testing means

Folding rule, square

Auxiliary accessories

Straight batten for scribing of about 1300 mm length,

Straight batten for scribing step thickness, about 350 mm long and exactly 35 mm wide!

Necessary previous knowledge

Measuring, scribing, angling, testing

Explanations to the working drawing

The landing connections have been drawn on the drawing floor so as to show the surfaces of the stair foot (bottom step) and stair head (head step) on a joint horizontal line.

(1) landing connections drawn on the drawing floor

(2) details of bottom landing

(3) details of stop landing

St - gauge size, hw - string height

Sequence of operations	Comments
-------------------------------	-----------------

1. Draw a horizontal line on the drawing floor.	Draw a thin line over the entire drawing floor.
2. Determine the front edge of the top landing-apron and draw a vertical line downward.	Mind the stair flight direction! Apply the square exactly.
3. Measure-in the floor thickness d_2 .	Measure from 1 downward. Draw the line to 2 only.
4. Measure-in from 1 downward and scribe two heights of rise.	Draw thin lines.
	Draw line 4.1 as long as 1 and parallelly to 1. Lines represent surfaces of the steps.
5. Measure-in and scribe difference (40 mm).	Measure from 2 towards stairwell. Draw a thin line downward parallelly to 2. Line represents top stair string section.
6. Measure-in from 5 and scribe two tread widths.	Draw a thin line parallelly to 5.
7. Measure-in and scribe the step thickness.	Use batten (35 mm width). Apply batten in true alignment- (Batten is still to be used for scribing the stair strings!)
8. Measure-in and scribe the false tread.	Represents the front edge of the steps to be built in.
9. Measure-in and scribe the riser thickness.	Measure from 5 and 6 towards the stair-apron. Draw thin lines, not too long.

10. Draw dash-line over front edges of steps.	Draw very thin dash-line, which is only used for measuring-in the string top.
11. Draw dash-line over lower edges of risers.	Draw very thin dash-line, which is only used for measuring-in the string bottom.
12. Measure-in string top and scribe lower edge of stair string	Make sure it is parallel to 10. Line may be drawn slightly thicker.
13. Measure-in string bottom and scribe lower edge of stair string.	Make sure it is parallel to 11 and 12. The stair string height can be measured between 12 and 13!
14. Determine front edge of bottom stair-landing and drawn a line vertically downward.	Any distance from 2 may be selected. Draw a thin line.
15. Measure-in and scribe floor thickness d1.	Measure from 4.1 downward, draw a thin up to 14.
16. Measure-in and scribe false tread.	Draw a thin, short line.
17. Measure-in and scribe tread width.	Measure from 14 towards stair-well.
18. Measure-in and scribe riser thickness.	Measure from 17.
19. Measure-in string top and scribe upper edge of stair string.	Angle of inclination can be found by means of parallel displacement or gauge size (St)! Use the square!
20. Measure-in and scribe lower edge of stair string.	Measure h_w , from 10 downward! Use the square
21. Check again accuracy to size!	Correct, if necessary! 21 is not shown!
22. Limit stair string at bottom	Any size but bigger than or equal to 50 mm!

landing.

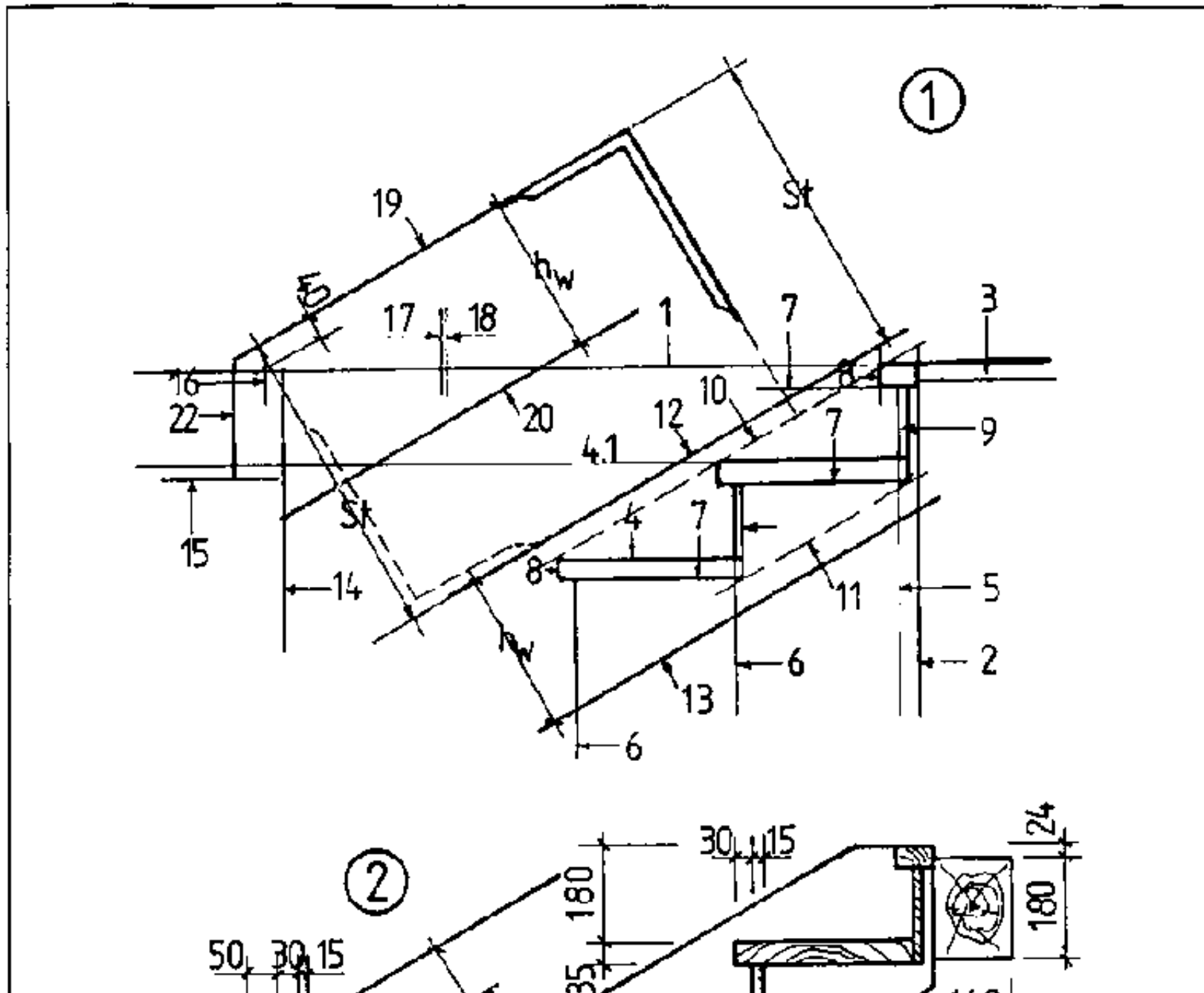

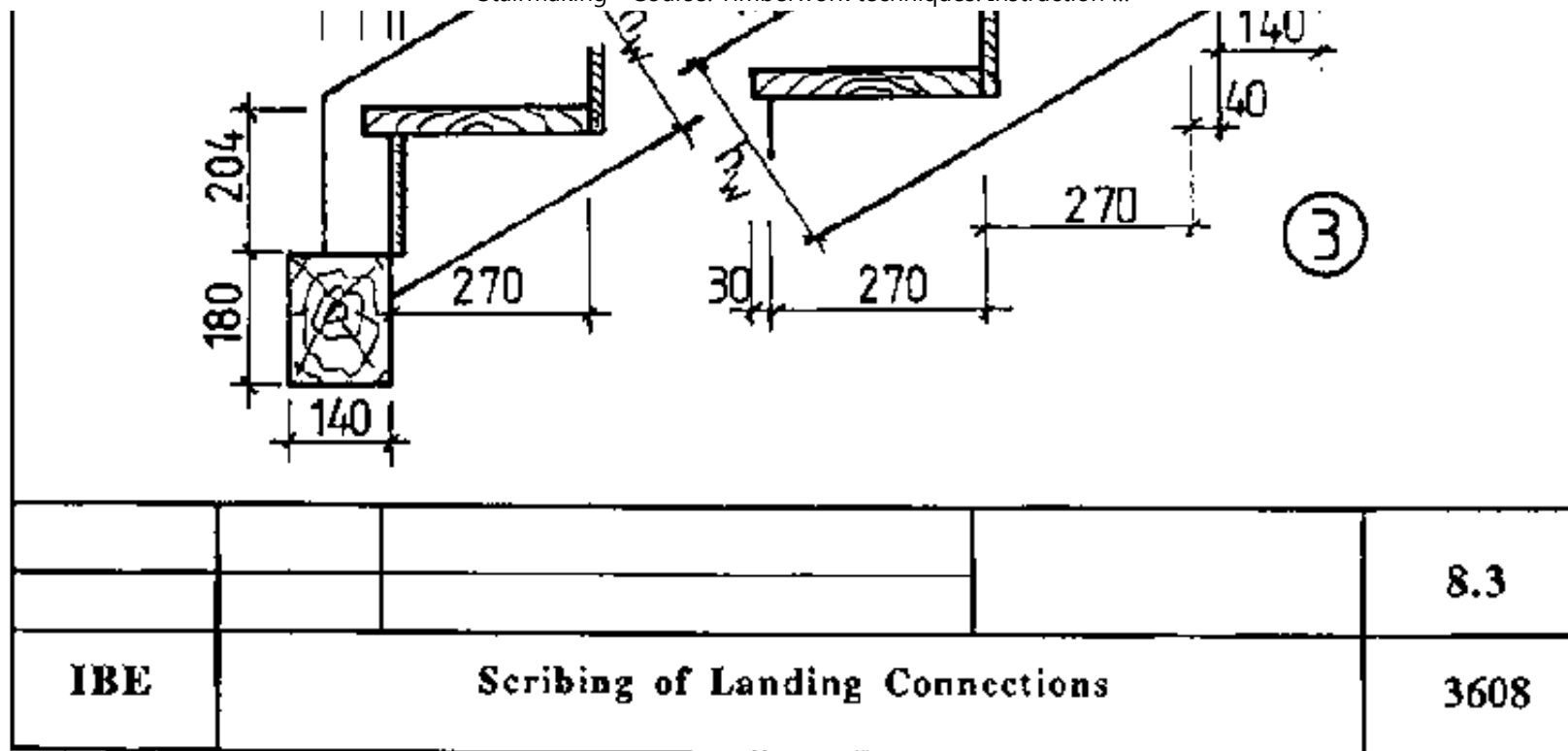

Scribing of Landing Connections

[Home](#) > [ar.cn.de.en.es.fr.id.it.ph.po.ru.sw](#)

 **Stairmaking - Course: Timberwork techniques. Instruction examples for practical vocational training (Institut für Berufliche Entwicklung, 34 p.)**







 **(introduction...)**

 **Preliminary Remarks**

 **Instruction Example 8.1.: Taking off Dimensions at the**



Stairwell

-  **Instruction Example 8.2.: Determination for the Ratio of Rise and Tread**
-  **Instruction Example 8.3.: Scribing of landing connections**
-  **Instruction Example 8.4.: Manufacture of Template and Angular Board**
-  **Instruction Example 8.5.: Scribing and Preparing the Stair Strings**
-  **Instruction Example 8.6.: Manufacture of Steps and Risers**
-  **Instruction Example 8.7.: Assembly of the Stair Flight**

Instruction Example 8.4.: Manufacture of Template and Angular Board

Assumed to be known:

- Height of rise = 180 mm
- Tread width = 270 mm
- String bottom = 40 mm
- False tread = 30 mm

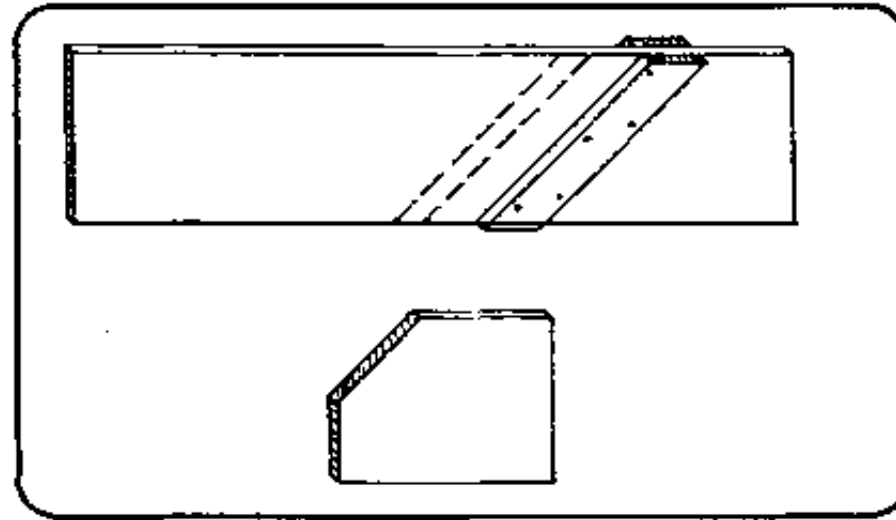

Figure

Hand tools

Hammer, jack plane

Measuring and testing means

Folding rule, square

Auxiliary accessories

Pencil, 50 mm long nails board, about 700 mm long, exactly 180 mm wide, 20 mm thick, batten, about 40 mm wide, 450 mm long, 20 mm thick, piece of board, 300 mm long, 200 mm wide, 20 mm thick

Necessary previous knowledge

Measuring, angling, scribing, sawing, manual planing, nailing

Explanations to the working drawing

(1) template for steps

(2) angular board for risers

1 batten, 2 board

b - any size, **u** - false tread, **a** - tread width,

VT - marking, **VS** - front edge of riser, **HS** - rear edge of riser, **s** - height of rise

Sequence of operations	Comments
1. Saw wide board to approximate length.	Scribe the angle.
2. Plane the board to exact width. (Width = height of rise)	Use the jack plane. Make sure parallelism!
3. Measure any size, mark and identify with "VT" marking.	Make short scribe-marking. VT = front edge of step.
4. Measure false tread (u) from "VT" marking, mark and transfer to bottom side of board.	Use the square!
5. Measure one tread width (a) from "u" mark, mark and scribe front edge of riser (VS).	Make short scribe-marking. Use the square..
6. Measure riser thickness from "VS" marking, mark, scribe and identify with "HS" rear edge of riser.	Make short scribe-marking. Use the square.
7. Draw a diagonal line from "VS" to "u".	Draw a thin dash-line. Apply

	square-leg exactly! (Dash-line represents stair flight inclination!) If the stair flight inclination is wrong, the stair string will not fit into the stairwell!
8. Draw a second line from "HS" in parallel with the drawn dash-line.	Ensure parallelism!
9. Measure-in and mark string bottom square with second dash-line drawn and draw thin line parallelly with dash-line; identify line with "UkW" marking.	Drawn line represents lower edge of stair string.
10. Nail a batten flush with the "UkW" line.	Plane the batten! Any width - approx. 40 mm.
11. Produce angular board.	Board length exactly $u + a$. Width bigger than s . Angular cuts at both sides.
12. Check the sizes of the template and angular board.	Correct, if necessary.

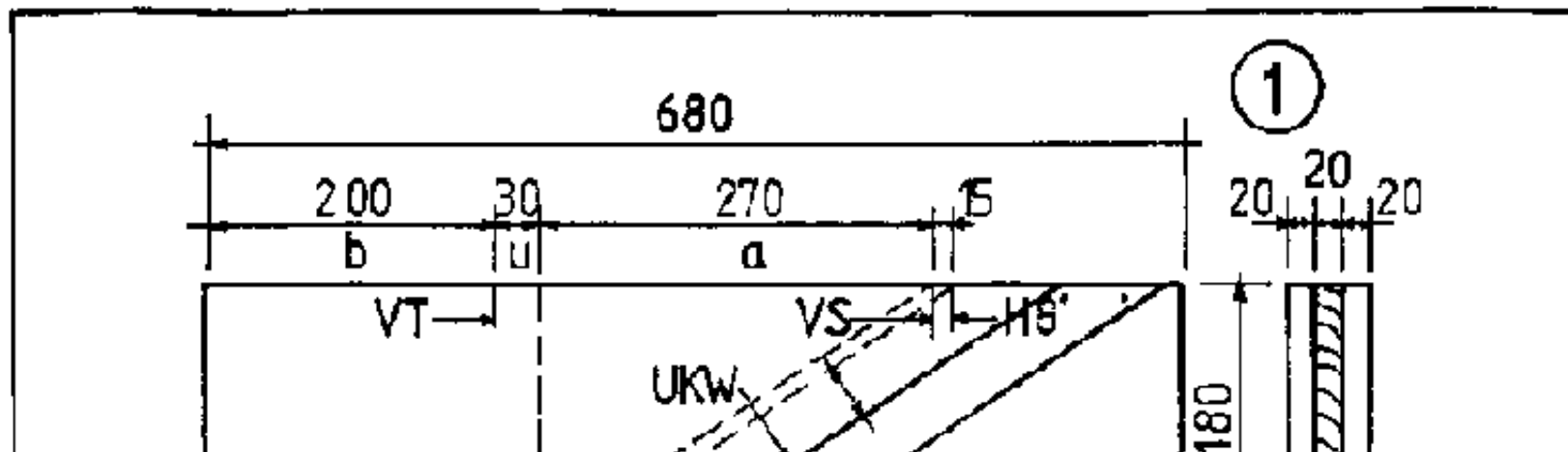

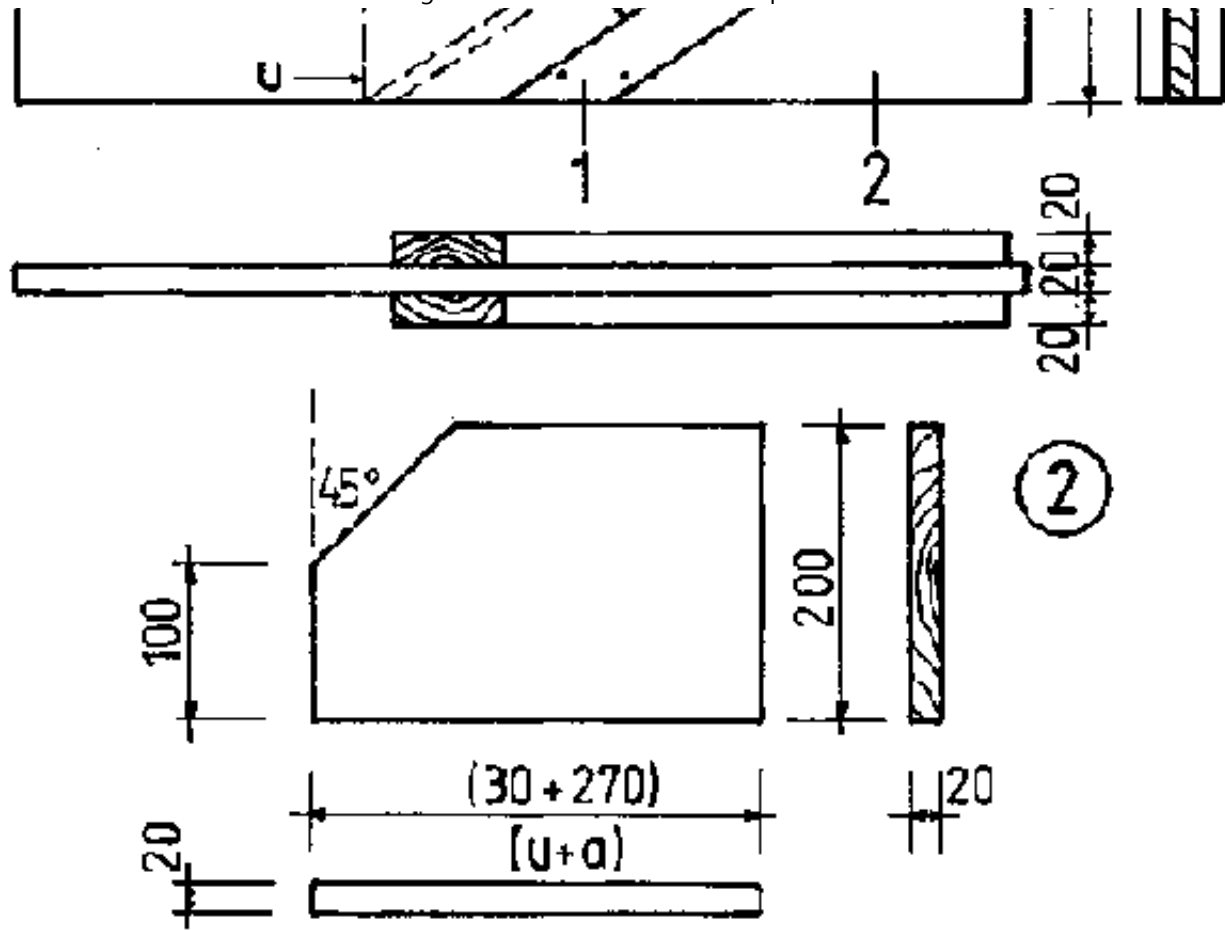

				8.4
IBE	Manufacture of Template and Angular Board			3608

Manufacture of Template and Angular Board





 **Stairmaking - Course: Timberwork techniques. Instruction examples for practical vocational training (Institut für Berufliche Entwicklung, 34 p.)**

 **(introduction...)**

 **Preliminary Remarks**

 **Instruction Example 8.1.: Taking off Dimensions at the Stairwell**

 **Instruction Example 8.2.: Determination for the Ratio of Rise and Tread**

 **Instruction Example 8.3.: Scribing of landing connections**

 **Instruction Example 8.4.: Manufacture of Template and Angular Board**

 **Instruction Example 8.5.: Scribing and Preparing the Stair Strings**

 **Instruction Example 8.6.: Manufacture of Steps and Risers**

 **Instruction Example 8.7.: Assembly of the Stair Flight**

Instruction Example 8.5.: Scribing and Preparing the Stair Strings

The wood of the stair strings is cut to width and thickness and planed on four sides.

Assumed to be known:

- **Stair string height = 290 mm**
- **Stair string thickness = 50 mm**
- **Step thickness = 35 mm**
- **Riser thickness = 15 mm**
- **False tread = 30 mm**

- $n_S = 9,$

$$m = \frac{270}{180}$$

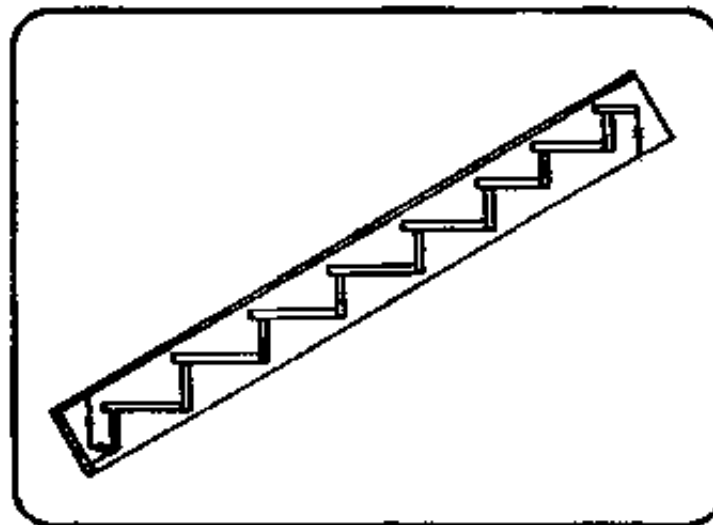

Figure

Hand tools

Hammer, hand saw, pad saw, ground plane, mortise chisels 12 mm and 24 mm, planing chisel, beating wood

Measuring and testing means

Folding rule, square, sliding T-bevel

Auxiliary accessories

Template, angular board, 35 mm wide and 400 mm long batten, abrasive paper

Necessary previous knowledge

Measuring, scribing, angling, mortising, cleaning, sanding, sawing

Explanations to the working drawing

- (1) scribing of the wall string**
- (2) bottom landing connection**
- (3) top landing connection**

Sequence of operations	Comments
1. Determine stair string length	

Required: L_W , $L_W = (n_S + 0.5) c$	
Known: $n_S = 9$	
$c = 325 \text{ mm}$	Measure from drawing floor.
$L_W = (9 + 0.5) 325 \text{ mm}$	
$L_W = 3087.5 \text{ mm}$	
$L_W \text{ selected} = 3150 \text{ mm}$	
2. Inspect string wood for grain flow and branch knots and identify with "F" or "W" marking.	"F" for outer string, use better surface. "W" for wall string.
3. Measure the size for the bottom step from the bottom landing connection and measure-in and mark on the string identified with "W" marking.	In this example approx. 500 mm
4. Set template to marking and scribe lower edge of step.	Set exactly! Scribe from "VT" to bottom edge of string.
5. Scribe step thickness.	Do not displace the template!

6. Scribe front edge of riser and front edge of step.	Put on batten (35 mm wide) and scribe from "VT" to "HS". Do not displace the template!
	Remove the batten and set the angular board ("VT" and "VS" must be flush). At "VS" scribe only between top and bottom surfaces of stop. At "VS" scribe over the entire length.
7. Scribe rear edge of riser.	Do not displace the template! Move angular board towards "HS" and scribe thin line over entire length. Set template and angular board exactly!
8. Scribe surface of bottom landing.	Move template towards surface of bottom step and scribe thin line at bottom side of template. Scribe over entire string height.
9. Scribe next step and riser.	Move template towards top landing connection until bottom side of template is flush with bottom surface of bottom step! Scribe at top side of template. Repeat working steps 5., 6. and 7. Set template exactly! (Bottom edge of pencil scribe-mark must be exactly flush with bottom side of template!)
10. Check scribed step for accuracy to size.	In case of deviations, re-work template and/or angular board.
11. Scribe remaining steps and risers.	Follow the sequence of operations! Always scribe bottom surface of step until bottom edge of string!
12. Put wall string on outer string and transfer bottom edges of steps.	Bottom sides of strings must be flush. Use the square. Lines should not be scribed too thick.
13. Scribe the outer string	Same procedure as for wall string. Always set top side of

13. Scribe the outer string.	Same procedure as for wall string. Always set top side of template to transferred angular scribe-markings to achieve exact mirror-image!
14. Scribe bottom landing connection.	Take off dimensions from drawing floor. Ensure parallelism with rise and tread!
15. Check again string section and mark with cross.	Draw lines a little thicker. Cross means section.
16. Scribe top landing connection.	Take off dimensions from drawing floor. Ensure parallelism with rise and tread!
17. Check again string section and mark with cross.	Draw lines of section a little thicker.
18. Prepare the stair strings.	Put strings on solid support to avoid springiness when mortising. Avoid tilting-up of the strings during mortising, otherwise danger of accidents!
19. Mortise all step holes of one string.	Do not put mortise chisel on pencil scribe-marking. Consider grain flow when mortising.
20. Check mortising depth of holes.	Leave about 1 mm on the hole bottom. Exact depth is achieved by means of ground plane.
21. Mortise the holes for the risers.	Use pad saw at opening for step. Use piece of wood so that the teeth of the pad saw cannot slip off. Consider grain flow!
22. Check mortising depth.	
23. Clean holes for steps and risers.	Re-chisel sensitively. Half of pencil scribe-marking must be left visible.

24. Slightly re-chisel edges of hole bottoms with mortise chisel.	Re-chisel sensitively, not too deep.
25. Plane hole bottoms for steps and risers to exact depth.	Use ground plane. Do not plane against grain flow. Guide ground plane sensitively to avoid damage to the hole edges and comers!
26. Saw-out top and bottom landing connections.	Ensure right-angle cutting.
27. Smooth strings with abrasive paper.	Use fine-grain abrasive paper. Do not sand-off hole edges! No scribe-markings must be left visible.

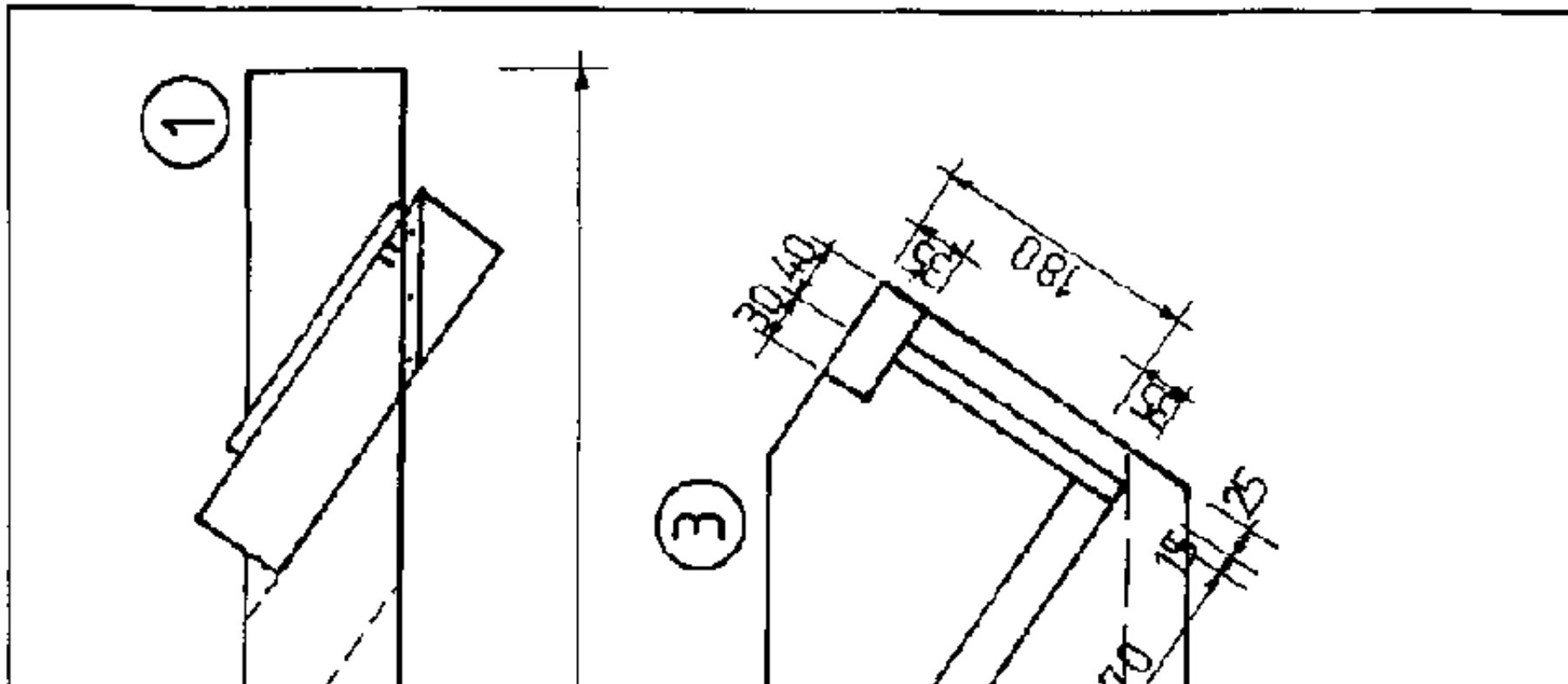

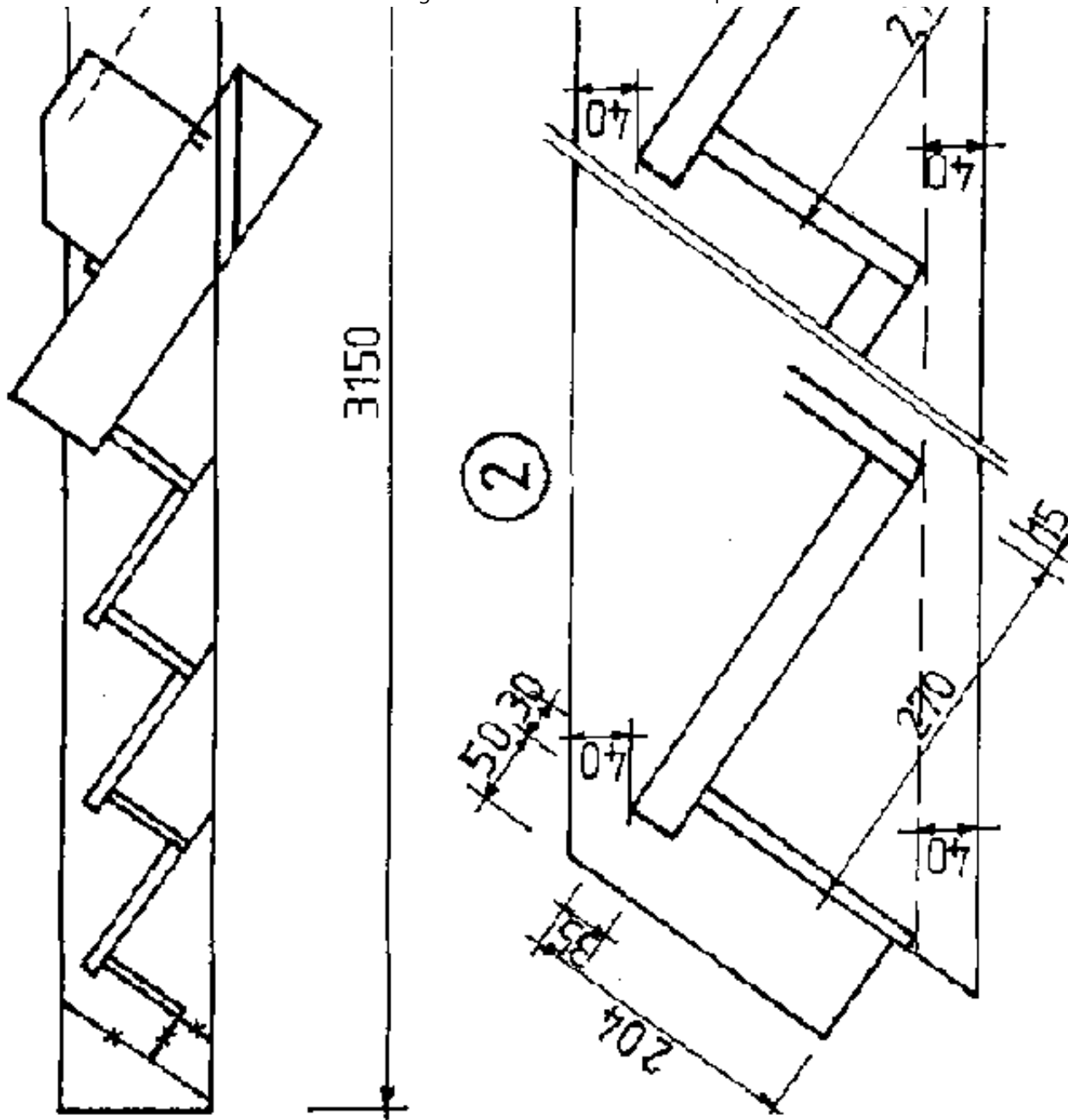

			8.5
IBE	Scribing and Preparing the Stair Strings		3608







Scribing and Preparing the Stair Strings



[Home](#) > [ar](#).[cn](#).[de](#).[en](#).[es](#).[fr](#).[id](#).[it](#).[ph](#).[po](#).[ru](#).[sw](#)



 **Stairmaking - Course: Timberwork techniques. Instruction examples for practical vocational training (Institut für Berufliche Entwicklung, 34 p.)**

-  **(introduction...)**
-  **Preliminary Remarks**
-  **Instruction Example 8.1.: Taking off Dimensions at the Stairwell**
-  **Instruction Example 8.2.: Determination for the Ratio of Rise and Tread**
-  **Instruction Example 8.3.: Scribing of landing connections**
-  **Instruction Example 8.4.: Manufacture of Template and Angular Board**
-  **Instruction Example 8.5.: Scribing and Preparing the Stair Strings**





Instruction Example 8.6.: Manufacture of Steps and Risers



Instruction Example 8.7.: Assembly of the Stair Flight

Instruction Example 8.6.: Manufacture of Steps and Risers

The wood for the steps and risers is prepared with exact thickness, glued to approximate width and planed on three sides.

Assumed to be known:

- Step thickness = 35 mm**
 - Riser thickness = 15 mm**
 - False tread = 30 mm**
-
- $n_s = 8,$**

$$m = \frac{270}{180}$$

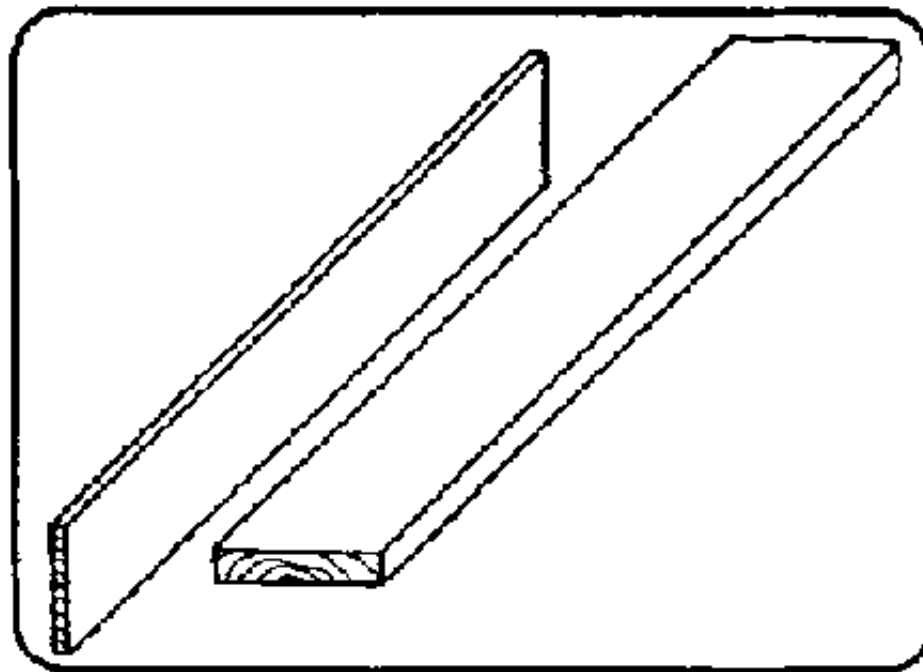

Figure

Hand tools

Hammer, hand saw, planing chisel, jack plane

Measuring and testing means

Folding rule, square

Auxiliary accessories

Pencil, straight batten, about 1100 mm long, 50 mm wide and 24 mm thick, abrasive paper

Necessary previous knowledge

Measuring, scribing, angling, smoothing (sanding), sawing

Sequence of operations	Comments
1. Inspect wood for steps for growth and branch knots and number it.	Number on cross-grain end. Grade surface quality starting with better surface from bottom step.
2. Determine step length.	Length = clear width of stair flight + two hole depths.
3. Put one step on workbench, scribe length and four right angles.	Set square exactly! Step is to be used as template for the remaining steps!
4. Scribe step width.	Ensure parallelism! Width = a + u!
5. Saw-out scribed step.	Cross-cut exactly on scribed lines. Longitudinal cut should be little wider than scribed lines (is to be planed!)
6. Plane step to scribed width.	Use jack plane. Ensure parallelism!
7. Put sawn-out and planed step as template on the remaining steps to be produced, one by one, and scribe-mark to such step.	Front edge of template to be put-on flush. Use sharp pencil. Attention: Head step must have less width!
8. Saw-out scribed steps.	Refer working step 5.!

9. Plane steps to exact width.	Use jack plane.
10. Manufacture head step.	Same length as the other steps. Width to be measured from top landing connection.
11. Smooth steps with abrasive paper.	Do not sand-off any chamfers! Use fine-grain abrasive paper.
12. Determine riser length.	5 mm shorter than step.
13. Put one riser on workbench, scribe length determined and four right angles.	Set square exactly. Riser is to be used as template!
14. Cut riser to length.	Saw exactly on scribed lines.
15. Manufacture remaining risers to such template.	Template to be set flush!
16. Smooth risers with abrasive paper.	Do not sand-off any chamfers. Use fine-grain abrasive paper.



[Home](#) > [ar](#).[cn](#).[de](#).[en](#).[es](#).[fr](#).[id](#).[it](#).[ph](#).[po](#).[ru](#).[sw](#)

 **Stairmaking - Course: Timberwork techniques. Instruction examples for practical vocational training (Institut fr Berufliche Entwicklung, 34 p.)**

 **(introduction...)**

 **Preliminary Remarks**



- 📄 **Instruction Example 8.1.: Taking off Dimensions at the Stairwell**
- 📄 **Instruction Example 8.2.: Determination for the Ratio of Rise and Tread**
- 📄 **Instruction Example 8.3.: Scribing of landing connections**
- 📄 **Instruction Example 8.4.: Manufacture of Template and Angular Board**
- 📄 **Instruction Example 8.5.: Scribing and Preparing the Stair Strings**
- 📄 **Instruction Example 8.6.: Manufacture of Steps and Risers**
- ➔ 📄 **Instruction Example 8.7.: Assembly of the Stair Flight**

Instruction Example 8.7.: Assembly of the Stair Flight

The prefabricated stair strings, steps and risers are to be assembled to a stair flight.

Additional material required:

Screw rods, washers, nuts, rosettes and wood screws.

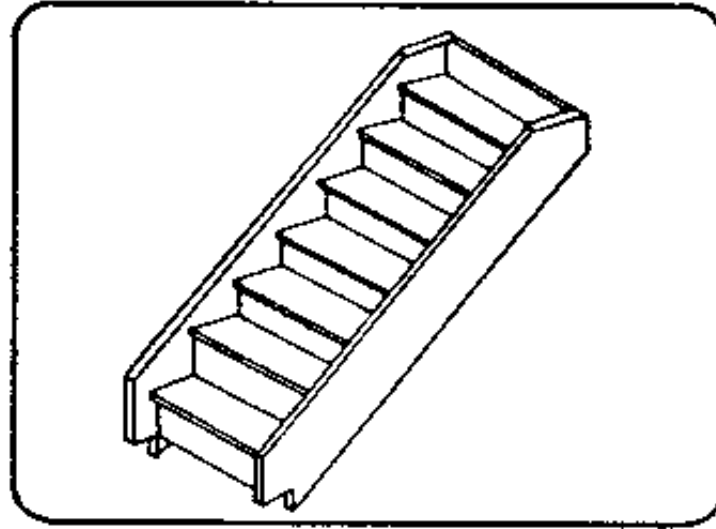

Figure

Hand tools

Plane, hammer, wrench (opening 13 mm), bit brace with 8 mm dia. bit, gimlet, screw driver, iron saw

Measuring and testing means

Folding rule, square

Auxiliary accessories

Wooden supports, wooden sections (several lengths from 500 mm to 1000 mm), nails of 50 mm shank length

Necessary previous knowledge

Drilling (boring), nailing, chamfering, (metal) sawing, screwing, sanding

Sequence of operations	Comments
1. Put one stair string on the other one, flush with each other, and scribe the holes.	Ensure flushing landing connection. Use wooden supports. String must not be springy.
2. Drill the holes.	Drill vertically to the string face.
3. Remove the wall string and put the screw rods into the outer string.	Put the screw rods in from the correct side.
4. Slightly chamfer the steps at the cross-grain end.	Use the plane.
5. Insert the steps in the mortised holes and slightly beat them in.	Put on a wooden section!
6. Slightly chamfer the risers at the cross-grain end.	Use the plane.
7. Insert the risers in the mortised holes and slightly beat them in.	Use a wooden section.
8. Put-on the wall string and enter the steps and risers into it.	Put the screw rods in first! Start from one landing connection.
9. Attach the washers and slightly screw-on the nuts.	Do not tighten the nuts too much.
10. Beat-in the wall string and re-tighten the nuts at the same time.	Use a wooden section. Do not apply force when re-tightening the nuts.
11. Check the wall string for tight fit.	Put-on a longer wooden section and

	beat-in the string. Check the clear size of the stair flight.
12. Finally tighten the nuts.	Do not tighten forcefully.
13. Saw-off any excessive thread length of the screw rods.	
14. Nail risers to rear edge of steps.	Nails must not penetrate through the surface of the steps.
15. Screw-on the rosettes.	
16. Smooth the stair flight with abrasive paper.	No pencil markings must be left visible!

