

➔  **Working with Driling Machines - Course: Mechanical woodworking techniques. Trainees' handbook of lessons (Institut fr Berufliche Entwicklung, 10 p.)**

 **(introduction...)**

 **1. The Purpose of Drilling with Drilling Machines**

 **2. Construction of Selected Drilling Machines**

 **2.1. Electrical Hand Drilling Machine**

 **2.2. Bench and Pillar Drilling Machines**

 **3. Tools**

 **4. Mode of Operation of Drilling Machines**

 **5. The Technological Process of Drilling**



 **Working with Driling Machines - Course: Mechanical woodworking techniques. Trainees' handbook of lessons (Institut fr Berufliche Entwicklung, 10 p.)**

➔  **(introduction...)**

 **1. The Purpose of Drilling with Drilling Machines**

 **2. Construction of Selected Drilling Machines**

 **3. Tools**

 **4. Mode of Operation of Drilling Machines**



## 5. The Technological Process of Drilling

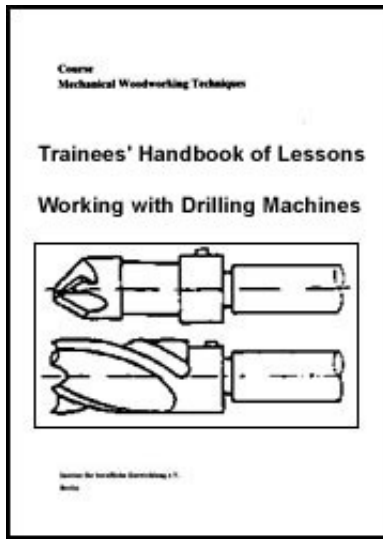

**Institut fr berufliche Entwicklung e.V.  
Berlin**

**Original title:  
Arbeitsmaterial fr den Lernenden  
"Arbeiten an Bohrmaschinen"**

**Author: Frank Wenghfer**

**First edition © IBE**

**Institut fr berufliche Entwicklung e.V.  
Parkstrae 23  
13187 Berlin**

**Order No.: 93-35-3403/2**





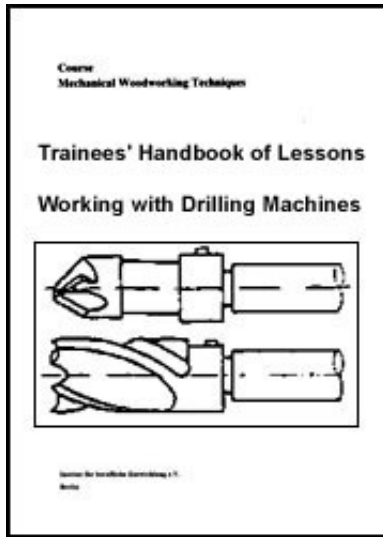



[Home](#) > [ar](#).[cn](#).[de](#).[en](#).[es](#).[fr](#).[id](#).[it](#).[ph](#).[po](#).[ru](#).[sw](#)



 **Working with Drilling Machines - Course: Mechanical woodworking techniques. Trainees' handbook of lessons (Institut fr Berufliche Entwicklung, 10 p.)**

 **(introduction...)**

-   **1. The Purpose of Drilling with Drilling Machines**
-  **2. Construction of Selected Drilling Machines**
-  **3. Tools**
-  **4. Mode of Operation of Drilling Machines**
-  **5. The Technological Process of Drilling**

## 1. The Purpose of Drilling with Drilling Machines

**In the field of wood working, drilling machines are applied to produce bores with special tasks.**

**Selection of the machines according to their application:**

<b>Application</b>	<b>Type of machine</b>
bores with free assembly works	bench, pillar drilling machines, knot drilling machines, routing machines
horizontal bores	long hole milling cutters
several adjacent bores	dowel-hole drilling machines

## Bores are produced in order to

- manufacture through holes and countersinks to locate screws and mountings;
- manufacture bottom and through holes for dowel joints;
- eliminate defects in wooden parts.

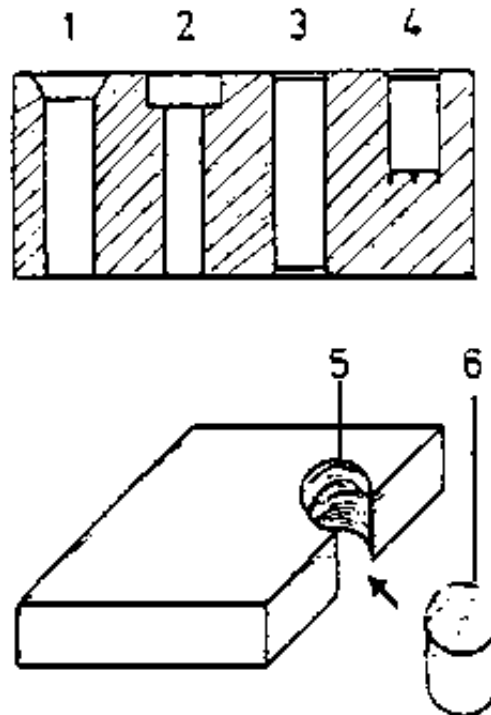
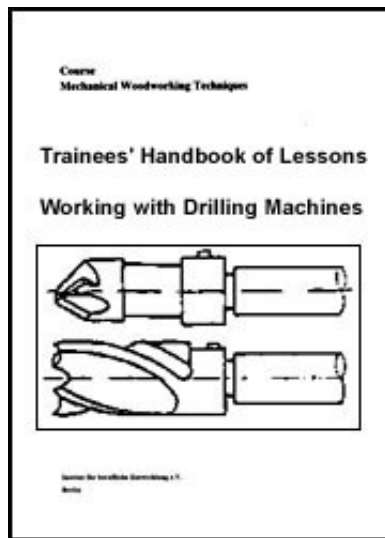

**Figure 1 - Bore types**

***1 bore for flat head screws, 2 bore for cylinder head screws, 3 through hole, 4 bottom bore for dowels, 5 drilled out defect, 6 wood disk to be***

***inserted***

[Home](#) > [ar](#).[cn](#).[de](#).[en](#).[es](#).[fr](#).[id](#).[it](#).[ph](#).[po](#).[ru](#).[sw](#)



 **Working with Driling Machines - Course: Mechanical woodworking techniques. Trainees' handbook of lessons (Institut fr Berufliche Entwicklung, 10 p.)**

➔  **2. Construction of Selected Drilling Machines**

 **2.1. Electrical Hand Drilling Machine**

 **2.2. Bench and Pillar Drilling Machines**

**Working with Driling Machines - Course: Mechanical woodworking techniques. Trainees' handbook of lessons (Institut fr Berufliche Entwicklung, 10 p.)**

## **2. Construction of Selected Drilling Machines**

### **2.1. Electrical Hand Drilling Machine**

**The light metal or plastic case contains the motor on whose prolonged arbor a whose chuck is placed to locate the drillers. Between the chuck and the case an additional hand grip can be mounted which can accommodate a depth stop.**

**Switching on and off is done by a switch above the hand grip which can be adjusted for a short time standing operation. In addition there can be switches to change the number of revolutions according to the type of drilling machine.**

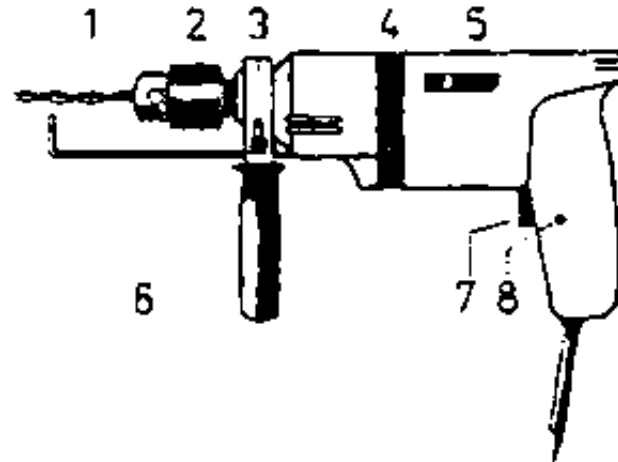

**Figure 2 - Electrical hand drilling machine**

***1 drill, 2 chuck, 3 additional hand grip, 4 case, 5 switch to select the number of revolutions, 6 depth stop, 7 on/off switch, 8 lock switch***

**The drilling machine should only be connected to a safety wall socket!**

**Damaged cables must not be applied!**

**The condition of the cable should be checked regularly and the clamp chuck must be kept clean!**

## **2.2. Bench and Pillar Drilling Machines**

**These drilling machines are applied to manufacture single vertical round bores for**

## mountings and countersinks at screw holes for mountings or single dowel bits.

### Joint features as to construction:

**A stable pillar carries in its upper part the driving mechanism with the motor and the gear as well as the operating elements to fix the number of revolutions and to carry out the feed. It is followed by the vertically flexible drill spindle for the accommodation of the drilling tools. Below the pillar there is the machine table where the workpieces can be fastened by different clamping means.**

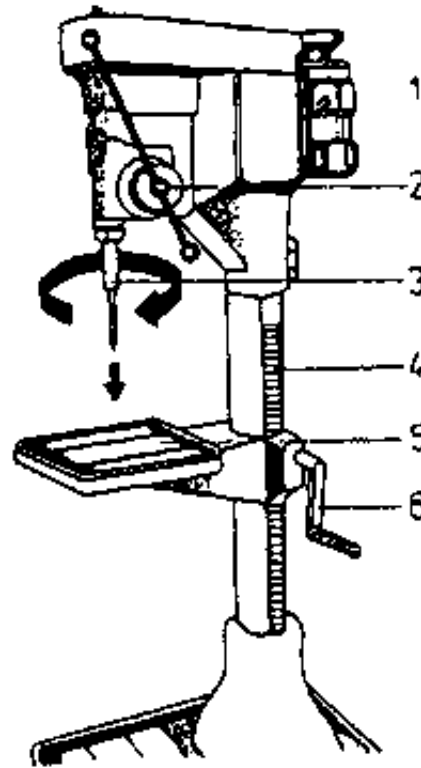

**Figure 3 - Pillar drilling machine**

***1 case with driving mechanism, 2 feed lever, 3 chuck, 4 pillar, 5 machine table (adjustable), 6 wheel for adjusting the height of the machine table***

**The clamping devices must guarantee a perfect and firm seat of the tools and the workpieces!**

**Existing eye protecting woods should be adjustable to the different heights of the drilling tools, they must not be removed!**

**Drill chuck and drill shank should be kept clean. The workpiece support and the clamping devices should be cleaned regularly!**

**The machine should be lubricated regularly according to the lubrication chart!**

**When do you apply bench or pillar drilling machines for wood working?**

---

---

---

**What requirements must be met by the clamping devices for the tools and workpieces?**

---

---

---





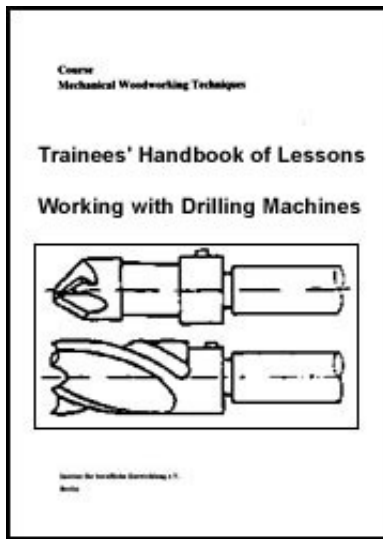

 **Working with Drilling Machines - Course: Mechanical woodworking techniques. Trainees' handbook of lessons (Institut für Berufliche Entwicklung, 10 p.)**

 **(introduction...)**

 **1. The Purpose of Drilling with Drilling Machines**

 **2. Construction of Selected Drilling Machines**

  **3. Tools**

 **4. Mode of Operation of Drilling Machines**

 **5. The Technological Process of Drilling**

### 3. Tools

#### Twist drill

**Twist drills with a roof-shaped point and a short robust shank are mainly applied for dowel bit bores in solid wood or cross grain wood.**

**Special dowel bit drills for multiple bores (which can be carried out with dowel bit drilling machines) have a screw on the robust shank.**

**Twist drills with a backed centre point (with 2 cutting edges) are applied for exact and clean through holes mostly across the grain.**

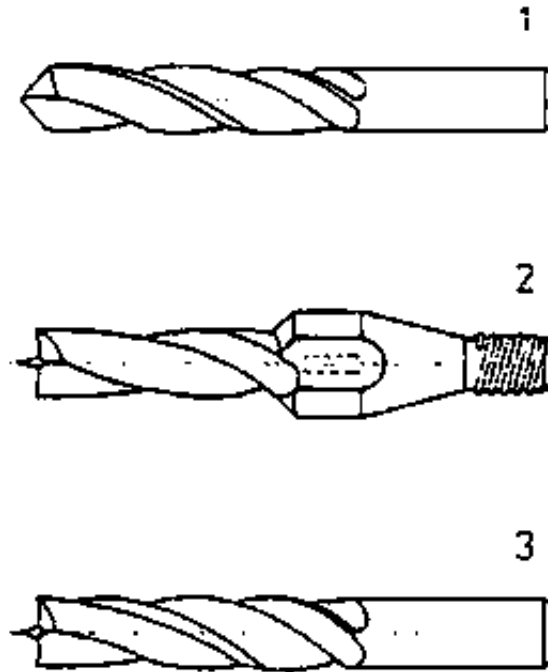

**Figure 4 - Twist drill**

***1 twist drill with roof-shaped point, 2 dowel bit drill, 3 twist drill with centre point***

## **Auger bit drill**

**They are mainly applied in hand drilling machines for deep bores.**



**Figure 5 - Auger bit drill**

## **Cylinder drill**

**They have a cylindrical bore head with which and dimensionally stable plain bores are carried out on even bore ground. They mainly have a larger diameter. They are suitable for boring out of defective parts and knots.**

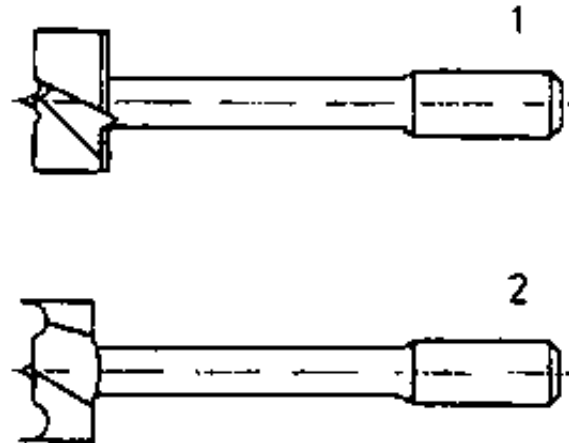
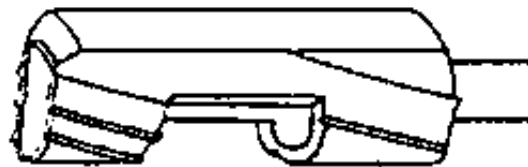

**Figure 6 - Cylinder drill**

***1 round shank Forstner bit drill, 2 circular rim auger bit drill***

### **Wood disk drill**

**They are also suitable for boring out of knots; but are mainly applied for manufacturing wood disks (cross wood dowels) which are placed instead of a drilled out knot.**



**Figure 7 - Wooden disk drill**

## Countersinks

**Depending on the form of head, conic bores for flat head screws can be manufactured or bores can be cylindrically enlarged in order to countersink screw heads.**

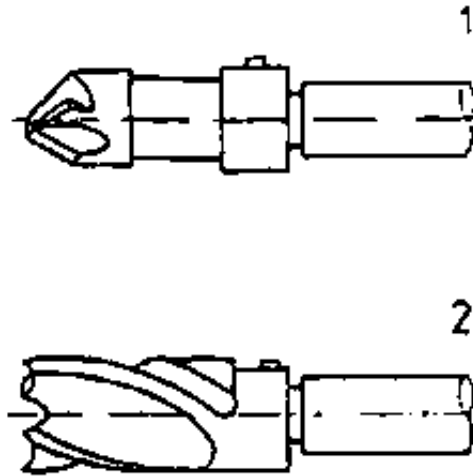

**Figure 8 - Countersink**

***1 countersink, 2 counterbore***

**After having finished drilling resin and dirt residues must be removed with hot water, petroleum or thinner!**

**Slight lubrication with acid-free grease protects the drilling tools against corrosion!**

**With which type of drill can be large bores on a even bore ground manufactured?**

---

---

---

## What are countersinks applied for?

---

---

---



[Home](#) > [ar.cn.de.en.es.fr.id.it.ph.po.ru.sw](#)

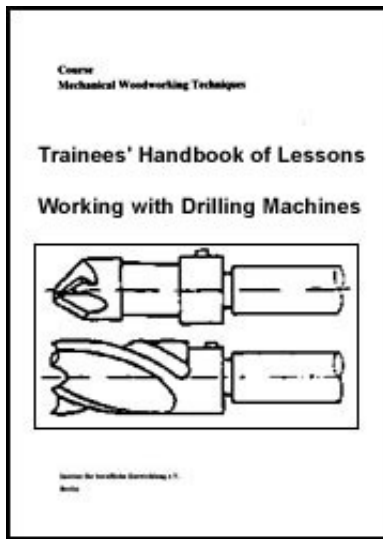

### **Working with Driling Machines - Course: Mechanical woodworking techniques. Trainees' handbook of lessons (Institut fr Berufliche Entwicklung, 10 p.)**

 **(introduction...)**

 **1. The Purpose of Drilling with Drilling Machines**

 **2. Construction of Selected Drilling Machines**

 **3. Tools**

 **4. Mode of Operation of Drilling Machines**

 **5. The Technological Process of Drilling**

## 4. Mode of Operation of Drilling Machines

**The switched-on electric motor puts the drill spindle through a gear into revolving movement. If by the feed lever the drill spindle together with the clamped tool is**

**moved into the feed direction the drilling tool can penetrate into the workpiece which is fastened on the machine table or being hold tight.**

**The revolving movement together with the feed movement effects the cutting by the drilling tool.**



[Home](#) > [ar](#).[cn](#).[de](#).[en](#).[es](#).[fr](#).[id](#).[it](#).[ph](#).[po](#).[ru](#).[sw](#)

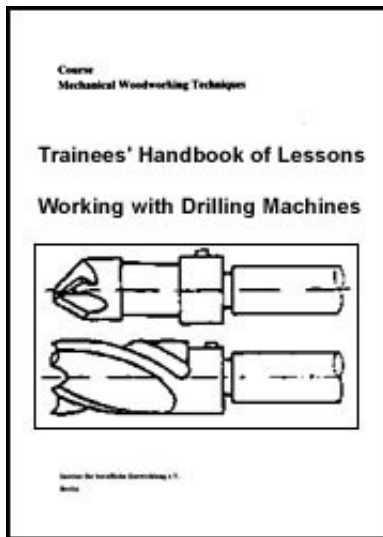

 **Working with Driling Machines - Course: Mechanical woodworking techniques. Trainees' handbook of lessons (Institut fr Berufliche Entwicklung, 10 p.)**

 **(introduction...)**

 **1. The Purpose of Drilling with Drilling Machines**

 **2. Construction of Selected Drilling Machines**

 **3. Tools**

 **4. Mode of Operation of Drilling Machines**

  **5. The Technological Process of Drilling**

## 5. The Technological Process of Drilling

### Marking the workpiece

**According to the measures in the technical drawing the marking is transmitted by a pencil and a marking gauge onto the piece of work. Thereafter the bore centre is**

**prepunched to achieve an accurate placing of the drill point.**

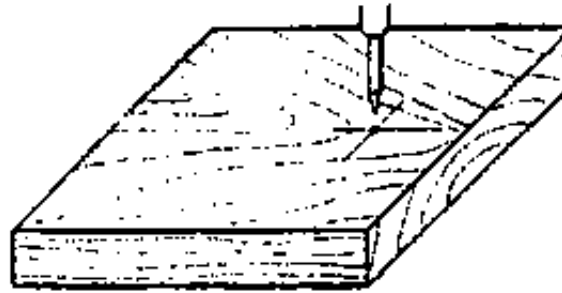

**Figure 9 - Marking and punching the bore centre**

### **Selecting and clamping the drill**

**According to the type of the bore and the material the suitable drill shall be clamped.**

**Pay attention to a firm clamping of the drill!**

### **Clamping or placing of the piece of work**

**Smaller workpieces are fastened on the machine table to avoid a snatching up or a twisting during drilling. Large workpieces are placed on the machine table and held by an assistant.**

**To avoid fraying out of wood fibres on the off-side of the bore a solid wood support should be placed under the workpiece.**

**In any case the workpiece should be secured against snatching up or twisting!**

**The prepunched bore centre must be adjusted exactly under the drill point.**

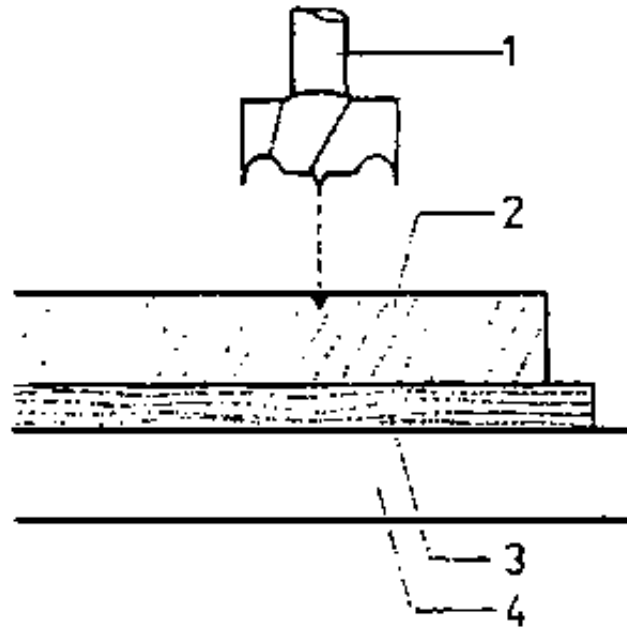

**Figure 10 - Adjusting the bore centre under the drill point**

***1 drill, 2 workpiece, 3 solid wood support, 4 machine table***

### **Carrying out the bore**

**Switching on the machine the drill is put into revolving movement. Now the drill is pressed on the workpiece by the feed lever. After having finished drilling the machine should be switched off.**

**Pay attention to a good chip flow during drilling!  
Only sharp drilling tools should be applied!**

### **Why are bore centres prepunched?**



---

---

---

**What should be paid attention to when placing the workpiece on the machine table?**

---

---

---

**How can fraying out of wood fibres on the off-side of the bore be avoided?**

### **Checking the bore**

**After drilling the dimensional stability of the bore, its diameter and depth as well as the quality of the bore edges are checked. Wood particles and unclean bore edges are faults which must be eliminated. In that case the bore should be countersunk slightly.**

