

**Surface Finish by Dyeing, Staining, Pigmenting, Matting and Polishing  
– Course: Manual woodworking techniques. Trainees' handbook of  
lessons**



# Table of Contents

<b><u>Surface Finish by Dyeing, Staining, Pigmenting, Matting and Polishing – Course: Manual woodworking techniques. Trainees' handbook of lessons</u></b> .....	<b>1</b>
<u>1. Purpose of Surface Treatment of Wood</u> .....	1
<u>2. Pretreatment Processes</u> .....	1
2.1. <u>Washing, Sanding and De-dusting</u> .....	1
2.2. <u>Deresinification</u> .....	3
2.3. <u>Bleaching</u> .....	4
2.4. <u>Dyeing</u> .....	5
2.5. <u>Staining</u> .....	6
2.6. <u>Pigmenting</u> .....	9
2.7. <u>Filling the Pores</u> .....	10
<u>3. Coating Processes</u> .....	11
3.1. <u>Basic Terms</u> .....	11
3.2. <u>Matting</u> .....	12
3.3. <u>Varnishing</u> .....	13
3.4. <u>Polishing</u> .....	15
<u>4. Selection of Chemicals</u> .....	16
4.1. <u>Acids</u> .....	17
4.2. <u>Solutions</u> .....	17
4.3. <u>Salts</u> .....	17
4.4. <u>Bleaching Agents</u> .....	18



# Surface Finish by Dyeing, Staining, Pigmenting, Matting and Polishing – Course: Manual woodworking techniques. Trainees' handbook of lessons

Institut für berufliche Entwicklung e.V.  
Berlin

Original title:

Arbeitsmaterial für den Lernenden  
"Oberflächenbehandlung durch Färben, Beizen, Pigmentieren, Mattieren und Polieren"

Author: Rolf Köllner  
Gerhard Piele

First edition © IBE

Institut für berufliche Entwicklung e.V.  
Parkstraße 23  
13187 Berlin

Order No.: 93–35–3309/2

## 1. Purpose of Surface Treatment of Wood

There are various techniques of surface treatment

- to change, as desired, the appearance of the surface of articles made from wood,
- to make the surfaces more resistant to mechanical and chemical influences.

In general one distinguishes:

- Pretreatment techniques, such as washing, sanding and de–dusting, deresinifying, bleaching, dyeing, staining, pigmenting and filling of pores,
- Coating techniques, such as matting, varnishing and polishing.

What is the purpose of surface treatment of wood?

---

---

---

## 2. Pretreatment Processes

### 2.1. Washing, Sanding and De–dusting

After having preworked the wooden parts, their surfaces are to be checked carefully. Surface that externally remain invisible may have faulty spots, if they do not warp later on. Those surfaces need not be treated. Surfaces which are externally visible should have uniform grain and uniform colour shades as well as be completely free from defects.

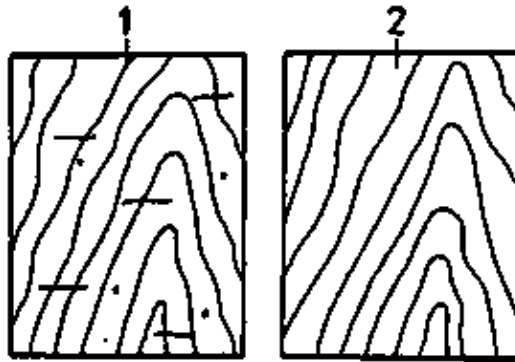

Figure 1 Checking the surfaces for faulty spots 1 fissures and holes in wood, 2 faultless wood

A proper surface finish is only then possible, when all the surfaces are completely clean, especially even and smooth as well as free from holes and imprints.

When staining agents or solvents are applied to wooden surfaces, wood fibres and pore brims of sanded surfaces straighten up again. Imprints caused by pressure on the wood may rise again and have a spoiling effect, too.

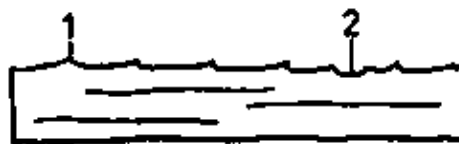

Figure 2 Enlarged cross-section of a board 1 upright wood fibres, 2 imprints

Therefore, wooden surfaces are to be washed with hot water without additives before they are finally sanded.

Procedure:

Washing is done with a sponge being rubbed with slight pressure over the surface. After having dried completely, the surfaces are to be re-ground and de-dusted.

The dry wooden surfaces are sanded with moderate pressure and coarse sandpaper, so that the risen pore brims are not pressed down, but ground off.

Much material is removed by sanding across the wood grain. In that case the surface shows, however, a great roughness.

Only a small amount of material is removed by sanding with the grain. Here the surface is, however, very fine.

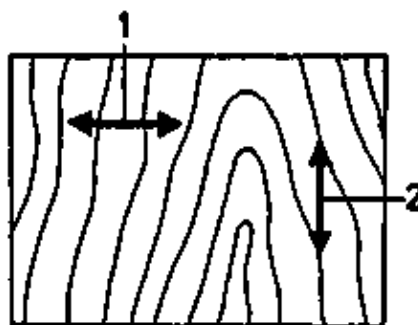

Figure 3 Sanding the surface 1 "across the grain", 2 "with the grain"

First grind "across the grain", then "with the grain". Use finer paper for each grinding process. Well ground is half polished.

After being washed and ground, the surfaces must be de-dusted thoroughly.

If surfaces are not correctly de-dusted, bright pores will show up, even after staining, having a detrimental effect. Moreover, adhesion of subsequent varnish coats is affected.

Why are wooden surfaces washed?

---

---

---

Which grinding direction results in a fine surface?

---

---

---

Why must the surfaces be freed from dust thoroughly?

---

---

---

## 2.2. Deresinification

Lightwood, especially coniferous wood, is to be treated in a particular way, since the resin components are water-repellent (staining-agent-repellent) and varnish-damaging. This may result in the appearance of spots later on. Solvents (acetone, fuel alcohol, diluent for cellulose lacquers) or saponifiers (curd soap solution, 10 % ammonium solution) help to deresinify the wood.

Application of solvents:

- Place wooden workpieces on a clean support.
- Apply solvent with cotton wad or sponge in stripes several times.

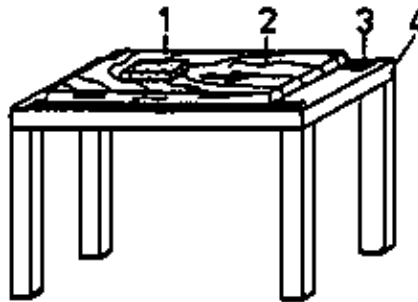

Figure 4 Applying a solvent 1 sponge, 2 board, 3 felt strip, 4 support

- Rub again with a clean, folded up piece of cloth or with a brush.
- Wash with warm water.
- Re-grind the surface with fine-grained abrasive paper.

Note – solvents are inflammable and detrimental to health.

Application of saponifiers:

- Place wooden workpieces on a clean support.
- Liberally apply the solution with a sponge several times and allow it to react for 10 to 15 minutes.
- Strongly brush the surface in wood grain direction.

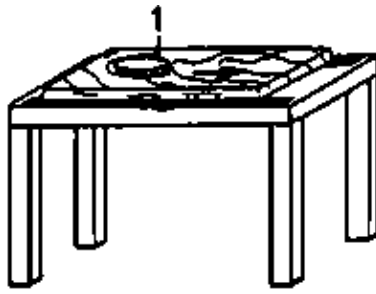

Figure 5 Brushing the wood surface *1 brush*

- Thoroughly wash the surface.
- Rub the wet surface with saw dust and clean it.
- Neutralize with 10% acetic acid and wash down with warm water.
- Re-grind the surface with fine-grained abrasive paper.

Recommendations:

- Wooden workpieces deresinified with solvents are not affected or changed in colour as is the case with saponifiers.
- After alkaline deresinifying agents have been used, the surface must be well washed and neutral otherwise undesired changes in colour occur during the staining process.
- Do not extract resin from light-coloured wood species with ammonia solution, otherwise the surfaces will darken.

Why must highly resinous wood species be deresinified before being stained?

---

---

---

What is the advantage of using solvents compared to saponifiers?

---

---

---

### 2.3. Bleaching

Discolourations and spots having developed during the growth of the wood or due to improper storage, as well as spots and stripes as a result of improper staining can be brightened up again or removed. The bleaching agents chemically destroy tannic acids or dyes.

Basic rule:

Always treat the entire surface.

Procedure:

- Place the wooden workpieces on a clean support.
- Mix bleaching agents, e.g. 30% hydrogen peroxide solution with 10% ammonia solution in small quantities as they are usable for a limited time only.
- Liberally apply the bleaching agent with a scraper covered with a white cloth or with a plant-fibre paintbrush without metal parts.

Bleaching agents are toxic and very caustic.  
Protect your hands with rubber gloves.



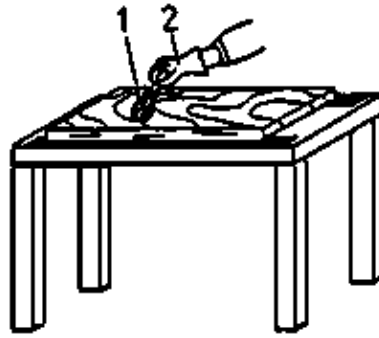

Figure 6 Applying the bleaching agent 1 scraper covered with a cloth, 2 rubber glove

- Leave the foam untouched for some time.
- Brush the surface with a hard brush.
- Thoroughly remove the bleaching agent with warm water.
- Let the material dry at ambient temperature for about 24 hours.

Recommendations:

- Spots that came about by rottenness cannot be removed with bleaching agents.
- If bleached wood is not coated immediately, it may darken again due to atmospheric oxygen influence.

Which wooden surfaces have to be bleached prior to subsequent treatment?

---

---

---

What is the basic rule for bleaching?

---

---

---

Why must the surfaces be thoroughly washed after having been bleached?

---

---

---

## 2.4. Dyeing

Dyes are dissolved in liquids such as spirit, water, oils, etc. and applied to wood in order to change its original colour tone.

In practice, this procedure is also called "staining", although the mode of action is different compared to the actual staining. When the solution penetrates the material, the colouring agents cause the dyes to precipitate in the structure and on the surface of the wood. The great absorptive capacity of soft spring wood tissues brings about a negative image of the texture:

After being dyed, lighter and softer wood spots become darker than denser and more solid ones.



Figure 7 Negative image of the texture after dyeing

Most dyes veil the wooden surface, so that the grain does not fully show to advantage. Therefore, dyeing is done in such a case when wooden surfaces without clearly visible texture are to be changed in their original colour tone.

The following colouring agents are used:

- water-soluble acid coaltar dyes
- alcohol-soluble alkaline coaltar dyes
- fat-soluble and oil-soluble coaltar and earthy dyes.

Acid and alkaline dye solutions must not be mixed together, otherwise the dye becomes ineffective.

Procedure:

- Place the wood on a clean support.
- Apply the colouring agent wetly and without interruption in wood grain direction.
- Distribute the dyeing agent uniformly.
- Put the wood aside and let it dry for about 24 hours.

Why are wooden surfaces without attractive texture dyed?

---

---

---

## 2.5. Staining

When liquids are applied to wood being rich in tanning agent, staining causes a chemical reaction in the wood.

Compared to dyeing, generally no dyes are introduced into the wood.

The chemical reaction starts when different salts combine, when acids and lyes are brought together or when salts are mixed with lyes or acids.

The full formation of the actual colour shade will only end after some time has passed. Staining underlines the wood texture optically and compensates different colour shades in the raw wood. Thus, the natural colour tone due to aging of the wood is imitated artificially.

The chemical deposition of the staining agents is light-fast, rubbing-fast and resistant to water.

The good penetrativeness of the solution, even into the dense autumn wood tissues, brings about a positive structural image:

After being stained, denser and more solid wood spots become darker than lighter and softer ones.



Figure 8 Positive image of the texture after staining

## Types of stains

### *Stains for double-staining (pre-staining and re-staining):*

Due to age, location and uneven distribution in the wood, the tannic content is different in various wood species. When the material is pre-stained, tannic acid is added and evenly distributed.

After drying, a metallic salt stain is applied as re-staining agent, the salt of which develops certain colour shades with the now existing tannic acid.

Different pre-staining agents, together with different re-staining agents, produce various colour shades.

Prepare only as much pre-staining agent as being used a day. Light influence disintegrates the pre-stain.

### *Stains for single staining:*

They are heavy metal salt solutions enriched with additional dyes, but only suitable for tanniferous wood species.

Wood treated with double and single stains must not be varnished with polyester varnishes. Otherwise solidification of the wood would be impeded.

### *Wax stains:*

They are solutions containing undissolved metal salts, dyes or pigments and wax additives.

Due to the wax portion, a dull shine will be obtained, with the grain, however, being slightly veiled by the dye portion. Wax stains are only suited for small-size parts of all kinds of wood, but not for furniture industry.

### Staining with single stain:

- Place wooden workpieces on clean support.
- Check whether all fittings (locks, bolts, plates) have been removed.
- Apply staining agent in grain direction with great wetness and without intermitting, if possible.
- Again apply staining agent after a reaction time of 2 to 4 minutes, in order to ascertain the envisaged staining effect (Surfaces should still be throughout wet and must not have dry spots.)
- A frse direction and then in longitudinal direction, so that excess staining agent is sucked up and no streaks being left.

Often squeeze out the paintbrush.

- After drying smooth the surface by brushing with a hard brush in grain direction. Why are wooden surfaces with clearly visible texture stained?

---

---

---

What is the difference in the reaction of dyeing agents compared to staining agents?

---

---

---

### Staining rules

- Leave any workpiece, before being worked, untouched for 24 hours, at least, at a temperature of 20°C, so that all the pores are opened and the staining solution can penetrate well. Make the staining agent available at the same temperature.

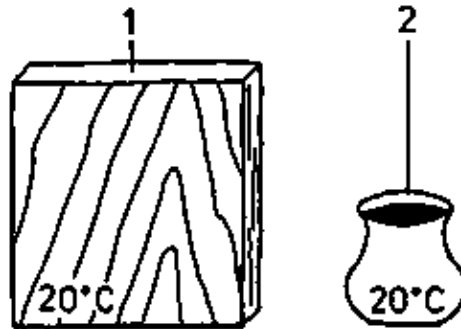

Figure 9 Making the board and staining agent available at same temperature of at least 20°C 1 board, 2 staining agent bin

- Use boiled water to prepare the staining agent. If tap water is used, staining defects may occur due to lime and iron substances contained in water.
- Remove all the metal parts, before staining, so that changes in colour may not occur.
- Before the staining solution is distributed, remove abrasive dust from all surfaces with a hard brush.
- Only use paintbrushes or sponges for staining. Paintbrushes should not have any iron parts, otherwise the staining agent would change in colour.
- Broad paintbrushes with well absorbent bristles are suitable to distribute the staining agent.
- Before applying the staining agent, undertake a stain test on a material as determined for the piece of furniture.

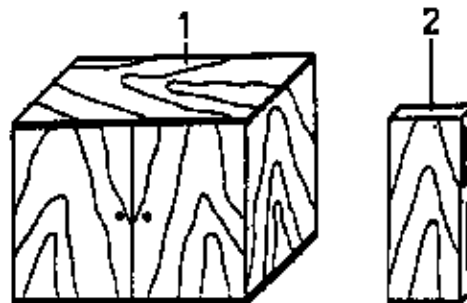

Figure 10 Staining test on a material of the same kind 1 piece of furniture, 2 staining test

- After the paintbrush has been dipped into the solution, let it drip off, in order to avoid spatters during its application.
- Brush upright surfaces from bottom to top, so that the staining solution may run down the wetted surface.

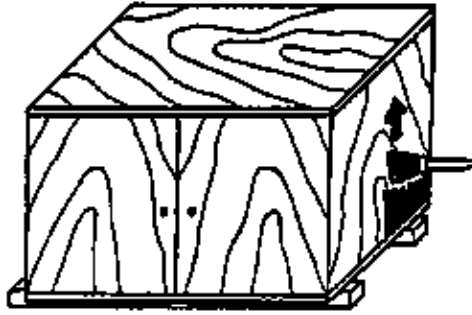

Figure 11 Applying the staining agent to vertical surfaces from bottom to top

- Cross-cut wood surfaces, before being stained, are brushed with clear water, so that they do not become too dark.
- Staining utensils should not be used for different solutions at the same time – the stained surface might become spotty.
- Do not return stain residues to the vessel, otherwise changes in colour may occur.
- Keep finish-stained parts away from drying in the sun – water and alcohol evaporate too quickly and prevent the development of the colour tone.
- After the staining agent has dried, soon apply the coat so that atmospheric oxygen does not change the colours any more.
- Store liquid stains in well closed bottles or earthenware bins, as atmospheric oxygen and light can change the colour tone of the stain.

Why is a staining test necessary before a piece of furniture is stained?

---

---

---

Why must the sample piece for the staining test be made of the same material and have the same coating as the piece of furniture itself?

---

---

---

Why must upright surfaces be stained from bottom to top?

---

---

---

## 2.6. Pigmenting

As for pigmenting, wood surfaces are coated with covering dyes or varnishes, with the texture being hardly visible afterwards or not at all.

Pigments are insoluble, finely ground paint particles of anorganic (metallic oxides) or organic (coaltar dyes) compounds to be added to staining agents or varnishes.

- Pigment stains give a slightly covering coat to the wood surface.
- Pigmented dull or glossy varnishes cover the wood texture completely.

Pigment staining procedure:

- Place the wood on a clean support.

- Thoroughly work the pigment staining agent into the surface.
- After complete saturation, the pigment staining agent is to be distributed under slight pressure, so that the covering effect of the coat can be fully reached.
- Give sufficient time to dry.

## 2.7. Filling the Pores

To obtain a smooth wood surface for varnishing and polishing, the existing surface cavities (pores) have to be filled up.

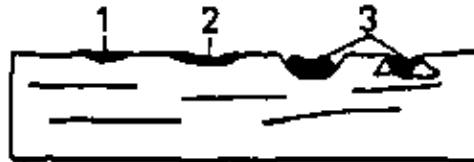

Figure 12 Enlarged cross-section of a board with filled pores *1 well filled, 2 incompletely filled, 3 incompletely filled and badly adherent*

Pore fillers to be used are 40 to 50 % of binding agents (dry oils or varnishes) and 50 to 60 % of pore filling powders (pumice powder, finely ground barium sulphate, powdered quartz, etc).

The colour tone of the pore filler is to be selected somewhat darker than that of the wood surface stained. Surfaces that are to be polished must be preferably filled with transparent fillers.

Sequence of operations:

- Brush the surface.
- Rub in the pore filler by circularly and at high pressure moving a rough linen ball over the wood surface.
- After drying wipe off the residual filler with a soft rag.

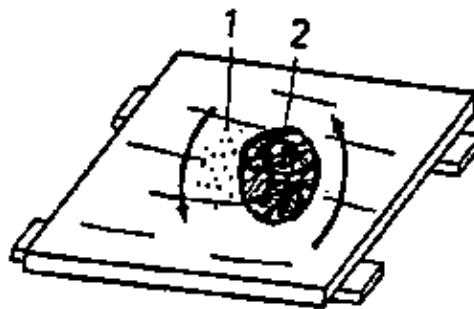

Figure 13 Rubbing in the pore filler *1 pore filler, 2 linen ball*

Recommendation:

Before the pore filler is rubbed in, the surfaces are to be thoroughly brushed in grain direction, so that the pore rim tips are torn off and the pore filler can be completely pressed into the cavity comers.

Why should pores on surfaces to be polished filled with transparent fillers?

---



---



---

### 3. Coating Processes

#### 3.1. Basic Terms

Lacquers or varnish paints that dry physically or harden chemically form a solid coating film improving the wood surface appearance and protecting it against mechanical and chemical influences. Stained or natural-coloured surfaces require transparent coats, so that the wood texture appears clearly and distinctly. The varnishes used are solutions of solid substances (natural or artificial resins) that, after being distributed are drying or hardening and thus, forming a solid film on the wood surface. The coating film consists of one or several layers to be applied shortly one after the other and partially "wet in wet" or after intermediate drying, respectively.

#### Coat layers

1st) *Priming coat:*

Priming agents, fillers or pre-stains even up slightly rough surfaces, close wood pores and form a pre-requisite for the varnish to adhere properly to the wood.

2nd) *Intermediate coat:*

Varnish layer thicknesses are enlarged and adhesiveness between prime and final coats are improved by priming paints or interlayer varnishes.

3rd) *Finishing or top coat:*

The required surface effect or the envisaged colour is obtained with matting agents or glossy varnishes.

#### Coating of surfaces

With open pores:

Pores have not been filled, but internal walls of pores have been coated with coating film.

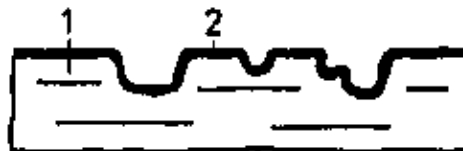

Figure 14 Surface with open pores 1 board, 2 coating

With semi-closed pores:

Pores have been filled only partially, while the remaining surface has been coated with a thin coating film.

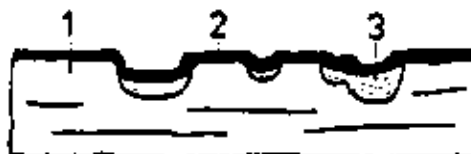

Figure 15 Surface with semi-closed pores 1 board, 2 coating, 3 pore filling

With closed pores:

Pores have been completely filled and are covered by a closed coating film.



Figure 16 Surface with closed pores

The desired porosity is obtained through various coating methods:

Matting:

Surface coated with transparent coating film. Its final appearance is yielded by a finishing procedure. Surface remains with open pores and is dull to dull–lustre.

Varnishing:

Surface coated with transparent or pigmented material. No further treatment of the surface. Surface has closed pores and is dull or shining, depending on the varnish constitution.

Polishing:

Surface coated with transparent or pigmented material. Final surface effect is reached not until after further operations (e.g. buffing or polishing with a cloth) and may be high–gloss, slightly polished or dull.

According to the finishing methods applied and the coating materials used, the following gloss grades are distinguished:

high–gloss:

Surface reflecting objects approximately without distortions.

dull–shiny:

Surface reflecting objects only unclearly and in a subdued manner.

slightly polished:

Surface reflecting objects distortedly or unclearly.

dull:

Surface reflecting objects not at all or only weakly and blurredly.

What is the task of cleanly carried out prime coats?

---

---

---

What is the porosity difference of matted surfaces compared to varnished ones?

---

---

---

### 3.2. Matting

All varnishes dry up with a special shine. In order not to produce a mirror like gloss with certain varnishes, but dull and silky lustre surfaces, matting agents are added to the varnishes. Such agents are finest ground substances (inorganic or organic compounds) added to the varnish at the amount of 5 to 20 %.

Coating operations:

- Spread the highly diluted matting agent with a paintbrush in grain direction at ambient temperature.
- Slightly grind the hardened prime coat with fine sandpaper with your LI LL
- Brush the surfaces until dust is removed.



- Apply hardly diluted matting agent with a cloth in wood grain direction until a uniform dull surface is obtained.

Recommendations:

- When wiping the surface, avoid touching the same spot twice, otherwise irritating glossy stripes will appear.
- If several coats are applied, the commensurate previous film must be properly dried, otherwise it may rise up and be torn off.

Along with the manual coating the mechanical spraying method may be applied.

Spraying operations:

- Prepare varnish, ensure its proper temperature and mix it. Make sure if the varnish is sufficiently diluted.
- Select spraying gun nozzle opening of about 1.8 mm; air pressure of about 3 at. overpressure; nozzle distance from surface of 250 to 300 mm approximately, hold spraying gun at an angle of about 45°.
- Spraying ensues cross-wise (i.e. "with the grain" and "across the grain"), pay attention to the surface edges.

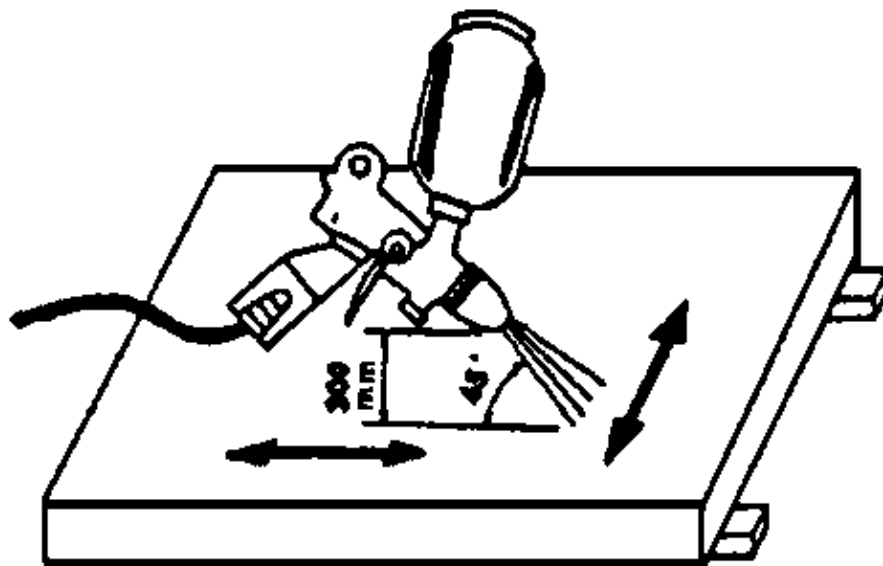

Figure 17 Crisscross spraying

Recommendations:

- Check varnish vessel for safety.
- Filter varnish, if required.
- Check whether compressed-air connection is leakproof.
- Apply a test coat.
- Select round jet for narrow faces and flat jet for wide faces.
- Observe respiratory protection while spraying.

What has to be especially observed when the matting agent is applied to the surface?

### 3.3. Varnishing

"Varnishes" are liquid coating agents without dyestuff additives. After drying they form a well-adhering film of particular gloss effect. Despite of the partially yellowish or brownish colour tone they are transparent. "Varnish

paints" are varnishes which pigments and dyes are added to.

Varnishes and varnish paints are mainly used as:

- Shellacs  
for house furniture, casings
- Oil and alkyd resin varnishes  
for kitchen furniture, garden furniture, windows and doors, wooden structures
- Nitrocellulose varnishes  
for interior furnishings, house furniture, rack and shelf furniture, toys, casings
- Acid-hardening varnishes  
for interior furnishings, house furniture, rack and shelf furniture, kitchen furniture, office and school furniture, garden furniture, casings, windows, doors, parquet
- Polyester varnishes  
for interior furnishings, house furniture, kitchen furniture, casings
- Polyurethane varnishes  
for interior furnishings, all kinds of furniture, doors, staircases, parquet

Varnishing ensues in a making up process:

After the first varnish coat has dried and a possible intermediate grinding has been carried out, the next varnish coat is applied. This procedure is repeated several times until the required quality is obtained. Commonly used coating methods are, above all, painting, spraying, rolling, dipping, pouring.

Recommendations:

- Previous oiling of wood surfaces may cause damages, because oil is seldom compatible with coating agents.
- Wood to be covered with coating agents must have moisture content of 8 to 10 %. More moisture would ooze to the surface later on and destroy the varnish film.
- Prior to the coating of wood surfaces, varnishing tests are to be carried out, in order to find out the reaction of the materials.
- Prime coats are to be made as lean as possible (highly diluted), with each subsequent coat having to be made less diluted than the previous one.
- The required drying spells of 6 hours must be adhered to following each spraying operation (except in case of "wet-in-wet" application of polyester varnishes).
- Wooden workpieces the surface of which is coated with polyester varnishes, have to be laid down horizontally for at least one hour, so that the varnish film will have a uniform thickness and does not run off. The second varnish coat should be applied "wet-in-wet" after 20 minutes, – just at the moment when the previous coat begins to jelly.
- After the final coating with nitrocellulose varnishes, a drying period of 4 days is needed.

Which damage may be caused, when too damp a wood is varnished?

---

---

---

### 3.4. Polishing

During the polishing process rough, dull and uneven surfaces are treated so that they will become extremely smooth and high-gloss. The objects being reflected on the polished surfaces should be mirrored as undistorted as possible. High-gloss surfaces must have a permanent shine – without any streaks or greyish shades. In this way the decorative aesthetic effect of the wood texture is particularly emphasized.

If the humidity in the polishing rooms is higher than 60 %, surface defects may be expected (greyish shades and "clouds").

If it is positive that a wooden workpiece is to be polished, it must be ensured that there are not any protruding edges on the wooden structure, so that the polishing balls and brushes can slide on the surfaces without interruption. If this condition cannot be fulfilled, the individual parts must be polished before being assembled. Wood with fine pores is especially suited for high-gloss varnish coats. Should, however, wood with large pores be used, its pores would have to be filled prior to the varnish application. Polishing always necessitates a closing of the wood pores with transparent fillers.

Making up process:

After the wood pores have been closed, the polish varnish layers are generally applied coat by coat manually until a film thickness is obtained, showing the desired shine.

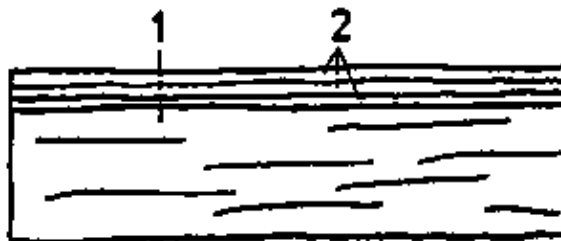

Figure 18 Making up process 1 board, 2 varnish layers individually applied

Smoothing process:

Film thicknesses excessively applied by spraying, rolling or pouring are removed by mechanical fine-grinding (buffing) with special grinding means and polishing brushes until the high lustre is obtained.

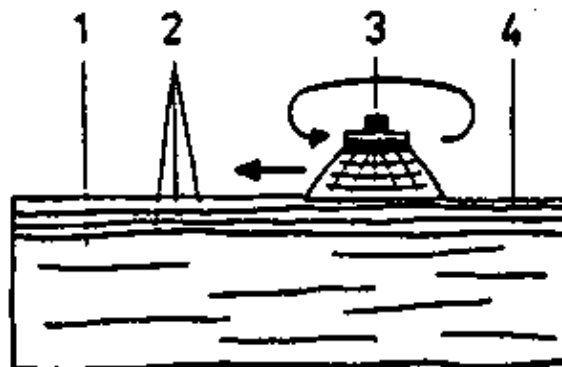

Figure 19 Smoothing process 1 board, 2 varnish layers individually applied, 3 polishing brush, 4 varnish coat polished down

The varnishes used should have special properties. They must be resistant to heat and moisture, drying quickly and well grindable. They must not be brittle or sticky. Such varnishes must be labelled as being able to be sprayed on and ground.

#### Polishing rules for shellac polishes

- Polish completely dried wood only.
- In order to visually underline wood texture sparingly distribute drying oils on the surface – not too strongly, otherwise oil spots appear later on and the pores cannot be closed any more. Use pumice > I L Id polishing agent to fill the pores.
- A better priming may be effected with cellulose compounds, with the danger of oil bloom being avoided.
- Rub in pore filler at pressure (dyeing pumice with adhesive, diluted polish matching the polish).
- Use light-resisting colours to dye the pore fillers.
- Apply shellac polish coat by coat, let it dry inbetween and grind and smooth it always.
- Apply the first cover coating (the same applies to intermediate polishing too) without polishing oil in order not to include the polishing oil in the polish, by circularly moving the polishing ball. First, use coarser, then finer linen for the polishing ball.
- As for further coating, polishing oil must be added moderately to prevent the ball from aing to the surface. Let enough time pass for drying.
- After the drying process, intermediate polishing has to be done to make the surface resistant and to close it.
- Wipe the polishing ball uniformly and without interruptions.
- In order to remove the polish oil from the surface, final polishing has to be done. For that purpose, drops of styrax benzoin solution are to be sprinkled onto the working surface of the polishing ball. The gum benzoin takes the polish oil up to the surface top. Subsequently, remove the polish oil with diluted sulphuric acid, magnesium oxide or with polishing down solution.

### Polishing down agents

After the lacquer-coated surfaces have been given a high-gloss finish through polishing or other polishes have been completely polished down, the oil or polish wax residues must be removed in a final operation. Polishing down agents may also be solutions enriched with finest abrasive. As for shellac polishes, benzo dyestuff serves as polishing down agent. For that purpose, gum benzoin is dissolved with alcohol. It has an anti-rot effect and improves the elasticity of shellac polishes.

What is the difference between the smoothing and making up processes?

---



---



---

Why must the first cover coating (the same applies to intermediate polishing too) be always applied without polishing oil?

---



---



---

## 4. Selection of Chemicals

## 4.1. Acids

As for wood surface treatment, many acids are of importance, which are used either, due to their caustic effect, to remove old coating material or, due to the salt formation, to produce staining agents.

- Acetic acid ( $\text{CH}_3\text{COOH}$ ):

Acetic acid (caustic) is used to produce staining agents and as bleaching agent. It ranks as best neutralizing agent for wood surface treatment.

- Hydrochloric acid (HCl):

Chemically pure hydrochloric acid (caustic and toxic) is a good neutralizing agent for wood surfaces. It is used to brighten up staining agents and to bleach wood.

## 4.2. Solutions

Solutions are soapy and caustic and have other properties than acids. Salts arise in connection with acids. Solutions dissolve organic matters, such as textiles and paintbrush bristles.

### Saponification

When organic matters (resins, waxes, oils) are decomposed by inorganic solutions, one speaks of "saponification".

- Caustic–soda solution (NaOH):

Caustic–soda solution dissolves fats, oil and varnish paint coats and is used as deresinifying agent.

- Liquid ammonia ( $\text{NH}_4\text{OH}$  – ammonia water solution):

Ammonia water solution (caustic) is used as an additive to water–soluble staining agents (except iron salt staining agents). It can also be employed for tanning wood and removing fat and acid spots, as well as saponification means for the purpose of deresinification.

### Neutralization

When acids and solutions are mixed in a certain ratio, a reaction occurs that is neither acid nor basic. Here, water is set free and a salt being formed.

## 4.3. Salts

Salts are formed when acids and solutions, as well as acids and metals are brought into contact.

Salts are needed to produce colour shades on the wood surface. They react with tanning agents inherent in wood or added by re–staining.

- Potash ( $\text{K}_2\text{CO}_3$  – potassium carbonate):

It is used as an additive for pre–staining and re–staining processes, as a bleaching agent as well as for removing solutions and extracting resins.

- Glauber salt ( $\text{Na}_2\text{SO}_4$  – sodium sulphate):

It is used to stain coniferous wood and as a filler for dyes and staining agents.

– Soda ( $\text{Na}_2\text{CO}_3$  – sodium carbonate):

It is used for wood surfaces as an agent to remove stains and resins.

– with boric acid and is used as a bleaching agent. It is also used to clean one's hands from dyes and to produce water-proof staining agents as well as shellac compounds.

#### **4.4. Bleaching Agents**

Various acids and salts are able to remove spots and streaks from the wood surface. After having been bleached, the surfaces have to be thoroughly washed and neutralized.

– Iron-free hydrochloric acid:

to be diluted with water as an aqueous solution in the ratio of 1: 2 or 1: 4.

Hydrogen peroxide ( $\text{H}_2\text{O}_2$ ) –

30 % hydrogen peroxide with 10 % liquid ammonia results in a strong bleaching agent. The bleaching process starts under heat development and foam formation.

– Saccharic acid ( $(\text{CO}_2\text{H})_2$  – oxalic acid):

It brightens up all spots that have formed through oxidation. The wood must not be treated with oil afterwards, otherwise there would be greyish shades and spots. Oxalic acid is very toxic.