

Making of Floors – Course: Timberwork techniques. Instruction examples for practical vocational training

Table of Contents

<u>Making of Floors – Course: Timberwork techniques. Instruction examples for practical vocational training</u>	1
<u>Preliminary Remarks</u>	1
<u>Instruction Example 6.1.: Checking and Levelling of the Beams</u>	1
<u>Instruction Example 6.2.: Laying of Mated Surfaced Deals</u>	5
<u>Instruction Example 6.3.: Laying of Matched Surfaced Deals</u>	9
<u>Instruction Example 6.4.: Fixing of Skirting Boards</u>	12

Making of Floors – Course: Timberwork techniques. Instruction examples for practical vocational training

Institut für berufliche Entwicklung e.V.
Berlin

Original title:
Lehrbeispiele für die berufspraktische Ausbildung
“Herstellen von Fußböden”

Author: Horst Hofmann

First Edition © IBE

Institut für berufliche Entwicklung e.V.
Parkstraße 21/23
13187 Berlin

Order No.: 93–33–3606/2

Preliminary Remarks

The present material includes 4 selected instruction examples on the basis of which the essential sequences of operations with the laying of surfaced deals can be demonstrated with increasing degree of difficulty.

Skills as sawing, nailing, chopping, cutting and planing are explained.

It is recommended to begin with simple mated boarding in secondary buildings. Here, the required knowledge can be acquired and extended and consolidated later when other types of wooden floors are dealt with.

In order to facilitate the preparation and carrying out of the work, the required materials, tools and auxiliary accessories are indicated for each instruction example.

Furthermore, the basic knowledge is mentioned which is required for laying surfaced boards and which had already been imparted before.

It is recommended to repeat this previously acquired knowledge before starting the work. The process of working and the quality of work has to be constantly supervised and controlled by the instructor.

To each instruction example a working drawing is attached which will contribute to a better understanding of some techniques and auxiliary means, as well as of the sequence of operations.

Instruction Example 6.1.: Checking and Levelling of the Beams

In the course of this exercise the beams are checked for equal height and horizontal position, and uneven surfaces are smoothed.

Material

– Boards

Thickness: 1–15 mm, also with wedge-shaped ends
Width: Same as the beams

– Nails

Length: approximately 40 – 60 mm

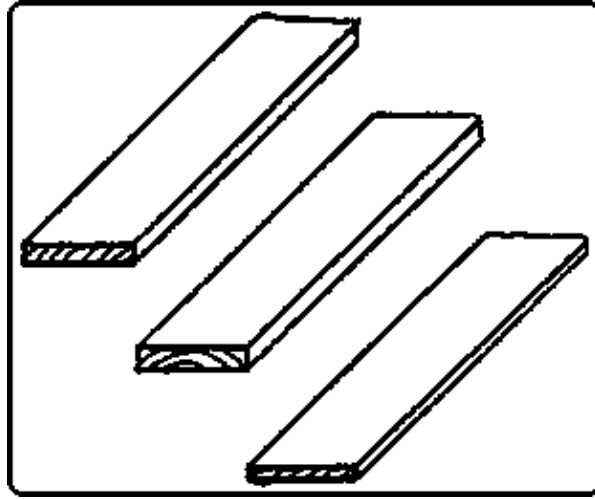

Tools

Hand saw, hammer, axe, plane

Measuring and testing means

Folding rule, water-level, level board (a straight, parallel, long plank)

Auxiliary accessories

Trestles for supporting the material during working

Required basic knowledge

Testing, measuring, sawing, chopping, planing, nailing

Sequence of operations	Comments
1. Arranging the workshop place, preparing materials and tools.	Check the tools for their completeness and serviceability.
2. Putting the level board across the beams along the wall, checking the beams as to equal height and, by using the water-level, to horizontal position.	Test the accuracy of the water-level before.
3. If the height is equal and the beams are horizontal, putting the level board lengthwise on a wall beam and checking horizontal position.	Make sure that the level board rests completely on the beam over its total length, if necessary, remove cuttings and the like.
4. If this horizontal line is guaranteed, too, putting the level board along the other wall across the beams and checking. If all beams are in horizontal position and of equal height, laying of the deals can be started.	If the beams were laid accurately, levelling of them before laying wooden floors is hardly necessary.
5. If the layer of beams is uneven, finding out the highest beam. Examining it in longitudinal direction and, if required, levelling it horizontally.	
6. Transmitting the height of this beam to the beams along the wall, levelling these horizontally according to the given height.	The heighest point may also be a wall beam; in this case level this and transmit its height to the opposite wall beam.
7. Then putting level board across the beams which are now horizontal and levelling the height of all beams in between.	Levelling is made by nailing boards on the beams the thickness of which equalizes the difference.

	<p>The beams are adapted in height over their full surface. Chop the boards to the required thickness – also with wedge-shaped ends – plane them or cut them with the help of a circular saw bench.</p>
8. Final checking.	

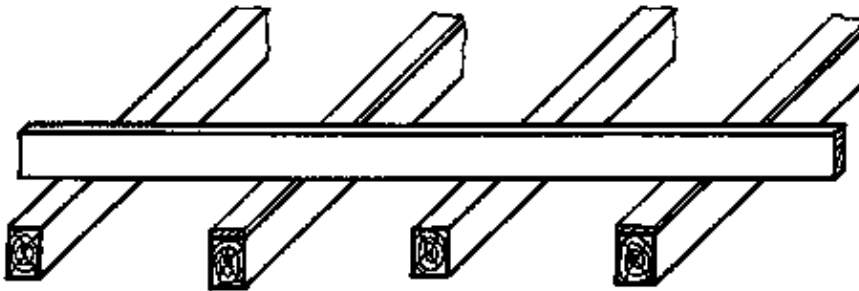
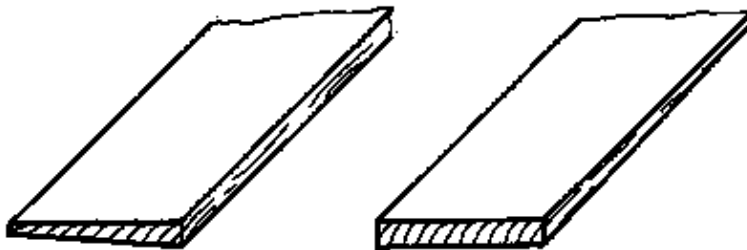
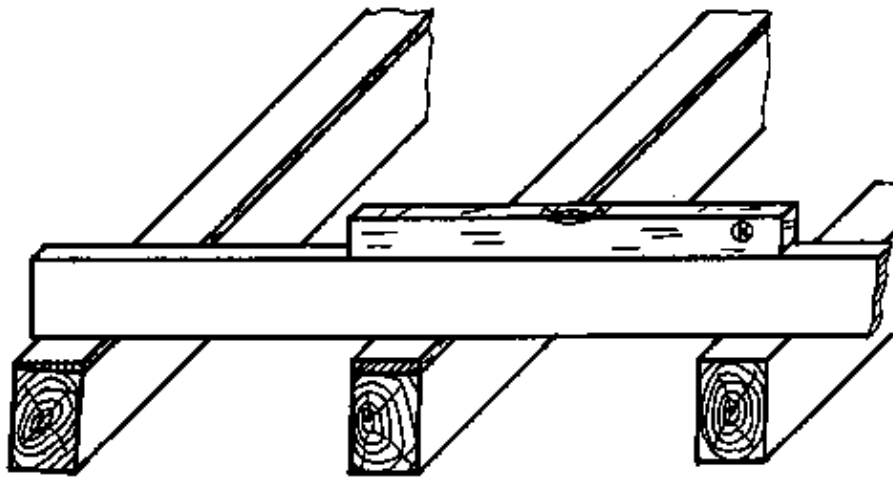

				6.1.
IBE	Beams (naked flooring)			3606

Beams (naked flooring)

Instruction Example 6.2.: Laying of Mated Surfaced Deals

In this instruction example the laying of mated surfaced deals is practised – a technique which is applied in buildings of secondary importance, such as sheds, lofts etc.

Material

– Surfaced deals, mated

Thickness: 24 mm
Width: 120–160 mm
Length: 4000 mm

– Countersunk head nails

Thickness: 3.1 mm
Length: 70 mm

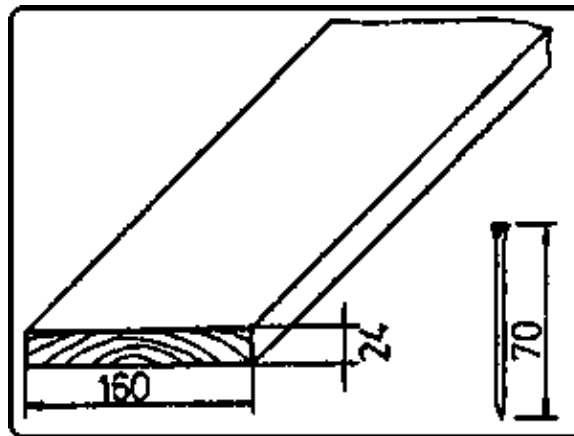

Tools

Hand saw with a tooth form suited for cross cuts, hammer, axe, plane, chisel, nail punch

Measuring and testing means

Folding rule, pencil, flat or try square

Auxiliary accessories

Trestles approximately 600 mm high, deal cramps or steel cramps, wooden wedges and pieces of planks

Required basic knowledge

Measuring, sawing, chopping, planing, nailing

Sequence of operations	Comments
1. Arranging the workshop place, putting the trestles for supporting the deals in place, preparing materials and tools.	Check the tools for completeness, test the keenness of the cutting tools.–
2. Measuring the room at several points across the beams.	Check whether or not all the lengths measured are the same.
3. Transmitting the determined length, less 10 –15 mm for an edge strip, on the deals.	If the deals have. the length of the room, 10–15 mm are deducted from the left and right end each for edge strips.

<p>4. Putting a square to the marking of the length, scribing and sawing to length with the hand saw.</p>	<p>If a number of deals shall be cut to the same length, they may also be put one upon the other and sawn at a time. The square can be put on the pile of deals and an additional vertical marking-out line be drawn.</p>
<p>5. Laying the first deal 10 – 15 mm distant from the wall and nailing it with two nails on each beam.</p>	
<p>6. Starting from the fixed deal five to six deals are put closely together.</p>	<p>The number depends also on the quality of the boards.</p>
<p>7. Driving a steel cramp in two to three beams at a distance of 100 – 150 mm from the deals laid, putting a piece of a plank and two wooden wedges between the deals and each cramp, tightening the wedges alternatively and evenly with the hammer this way pressing the deals together.</p>	<p>Wooden wedges are put one above the other only by their tips.</p>
<p>8. Drawing a thin line with lead pencil on the deals – middle of the beam – and nailing the deals from the front – cramps – to the rear.</p>	<p>Do not use a copying-pencil. The steps of work from point 6 to point 8 have to be done repeatedly.</p>
<p>9. For laying the last three deals measuring the space between the deals already laid and the wall, deducting the width of two deals and 15 mm for an edge strip from this measure, preparing the third deal according to the required size, then putting the deals in place. Pressing them together by driving wooden wedges between deal and wall and nailing them.</p>	<p>The last deal must be sawn off or chopped according to the required width and planed. In order to protect the plaster of the wall against damages, put a piece of a plank between the wooden wedge and the wall.</p>
<p>10. Driving in all nails two to three mm into the surface of the deals with a nail punch.</p>	
<p>11. Cleaning the deals and removing superfluous material from butts or joints with a plane.</p>	<p>Before planing make sure that all nails are counter-sunk. By smoothing a uniform and even surface is achieved.</p>
<p>12. Final checking.</p>	

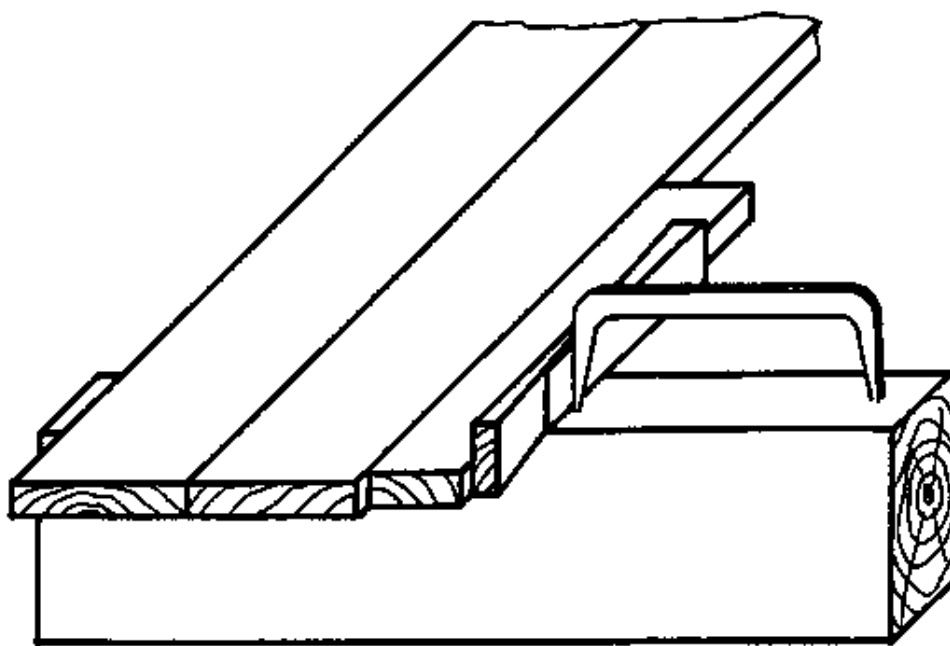
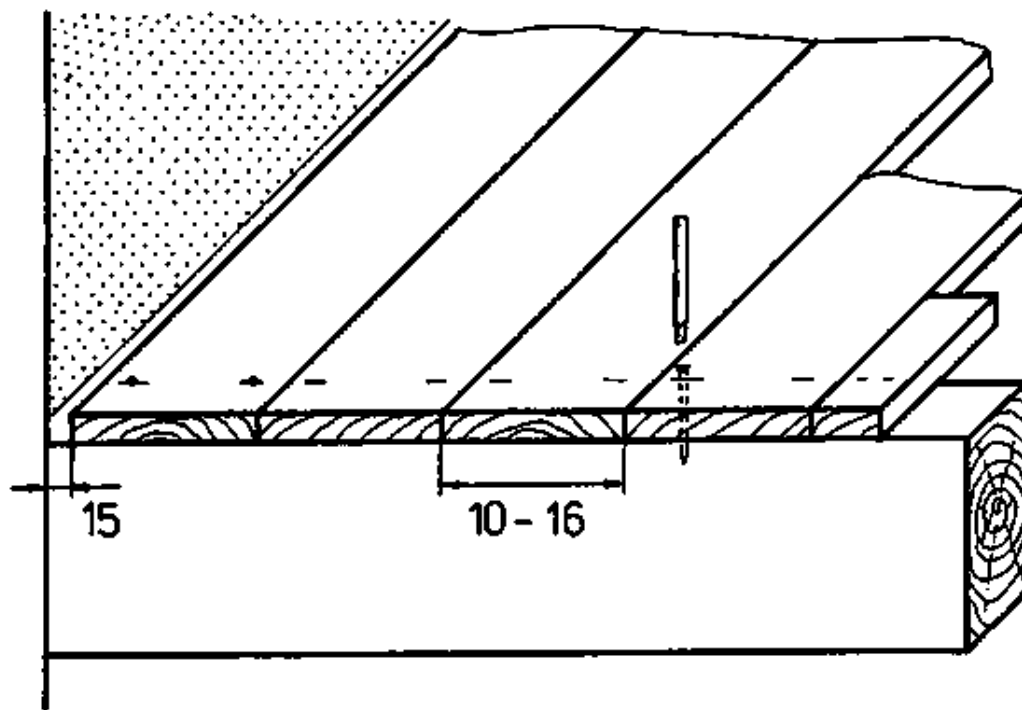

				6.2.
IBE	Mated surfaced deals			3606

Instruction Example 6.3.: Laying of Matched Surfaced Deals

This instruction example is a practising exercise of laying matched surfaced deals.

Material

– Surfaced deals, matched

Thickness: 24 mm

Width: 120 mm

Length: 4000 mm

– Countersunk head nails

Thickness: 3.1 mm

Length: 70 mm

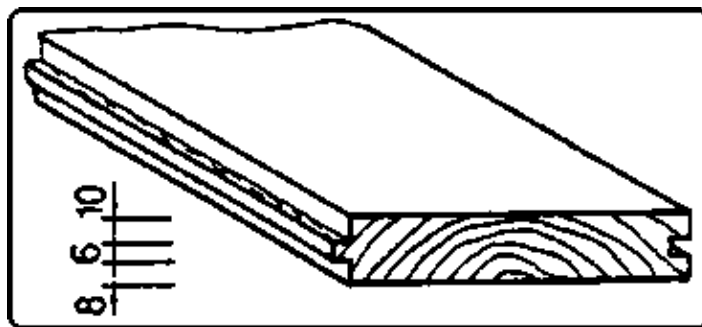

Tools

Hand saw with a tooth form suitable for cross cuts, hammer, axe, plane, chisel, nail punch

Measuring and testing means

Folding rule, flat or try square

Auxiliary accessories

Trestles approximately 600 mm high, deal cramps or steel cramps, wooden wedges and pieces of planks

Sequence of operations	Comments
1. Preparing the workshop place.	Check materials and tools for completeness, trestles for supporting the boards.
2. Measuring the room at several points.	Find out whether or not the length is the same over all distances measured.
3. Transmitting the determined length to the deals less 10–15 mm for an edge strip.	If the length of the deals is the same as that of the room, 10 to 15 mm for edge strips are deducted left and right.
4. Applying a square to the marking of the length, scribing and sawing the boards off accordingly with a hand saw.	If a number of deals of equal length are required, they may be put one upon the other and sawn at a time. A square is applied to the pile of boards and an

	additional vertical marking is made.
5. With open nailing, removing the tongue from the first deal. With covered nailing removing the rabbet from the first deal by sawing, chopping or planing.	Rabbet is not so easily damaged when the deals are driven together. With covered nailing the nails are driven obliquely into the tongue.
6. Laying the first deal 10 – 15 mm distant from the wall – edge strip – and nailing it with two nails on each beam.	With covered nailing fix the first deal with one nail driven in vertically and one nail driven obliquely into the tongue.
7. Putting five to six deals loosely in front of the fixed deal and driving them together one by one.	In doing so, use a piece of a board or plank to protect the deals against damages.
8. Driving a steel cramp in two to three beams –according to the length of the deals – at a distance of 100 – 150 mm and putting a piece of a plank and two wooden wedges between the deal and each cramp. Tightening the wooden wedges evenly and alternately with the hammer.	The wooden wedges are put one above the other only by their tips (20 – 30 mm).
9. Drawing with the pencil a thin nailing line on the deals – middle of the beams – nailing the deals from the front – cramps – to the rear.	The working steps of point 7 to point 9 are repeated.
10. With covered nailing, pressing the deals together one by one and fixing them on each beam with a nail which is driven in the tongue obliquely.	By the oblique nailing the deals are drawn together once again.
11. Putting the last deals in – open nailing – laying two to three deals starting from the wall and nailing them.	In doing so, the exact width of two, better four, deals must remain free between these deals and those already fixed. The clearance must be given short measure, so that the boards are closely together.
12. Inserting the deals from above in an inclined way, putting a board across them and pressing them down.	
13. With covered nailing driving wooden wedges between the last deal and the wall and pressing the deals tightly together.	Put a piece of a plank between the wooden wedges and the wall, in order to prevent the wall plaster from being damaged.
14. With open as well as with covered nailing let the nails project 1–2 mm, put the nail punch on each nail and drive it in completely, so that it is driven in 1 – 3 mm in the surface of the board.	The nail punch is used so that the surface and front edge of the tongue are not damaged. Then the holes over the nails are puttied up.
15. Cleaning the floor and removing with a plane superfluous wood that might be projecting at butts and joints.	Once again make sure that all nails are driven in correctly.
16. Final checking.	

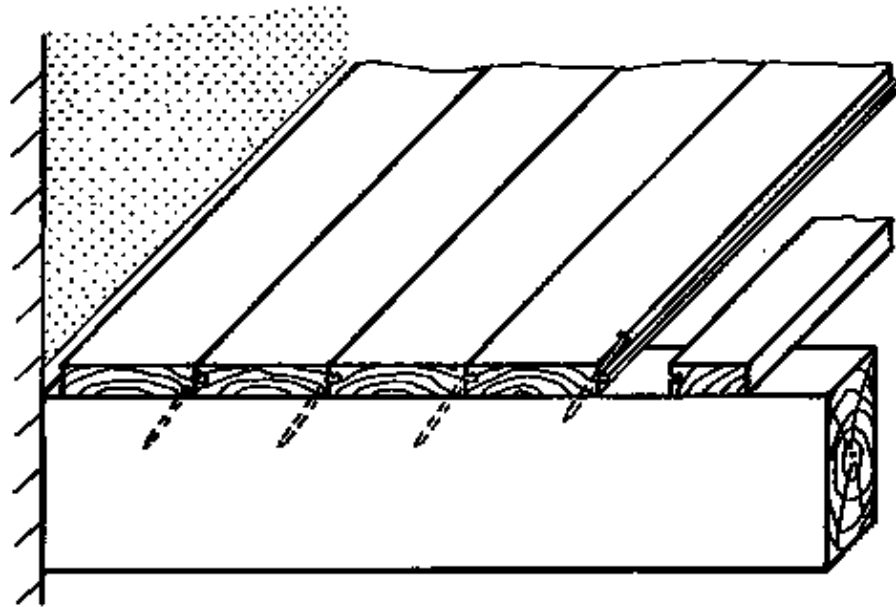
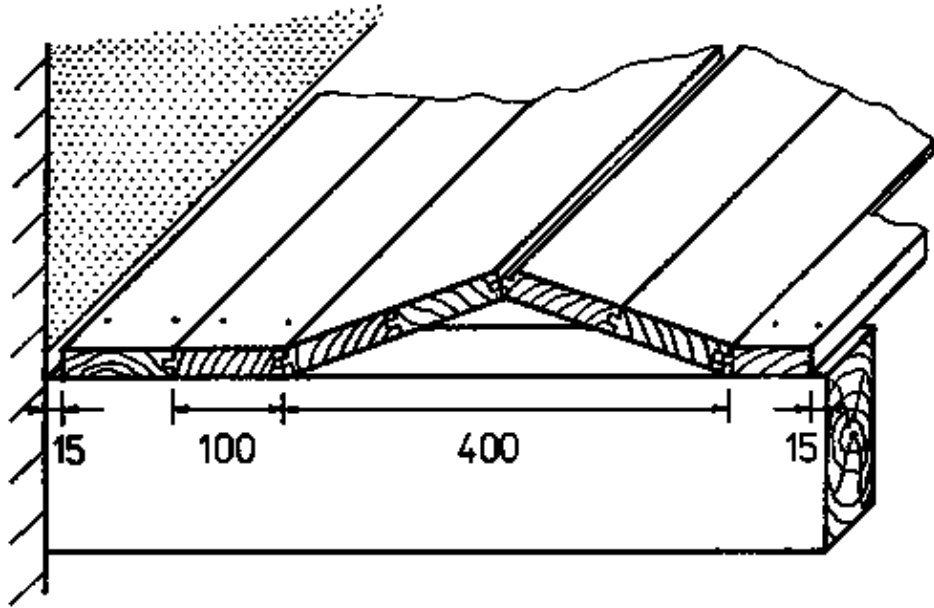

				6.3.
IBE	Matched surfaced deals			3606

Matched surfaced deals

Instruction Example 6.4.: Fixing of Skirting Boards

This instruction example shows how skirting boards up to 50 mm in height are nailed on the deals. The skirting boards may have different profiles according to the requirements.

Material

– Skirting boards

Height: 45 mm
Thickness: 24 mm
Length: 200–400 mm

– Countersunk head nails

Thickness: 3.1 mm
Length: 70 mm

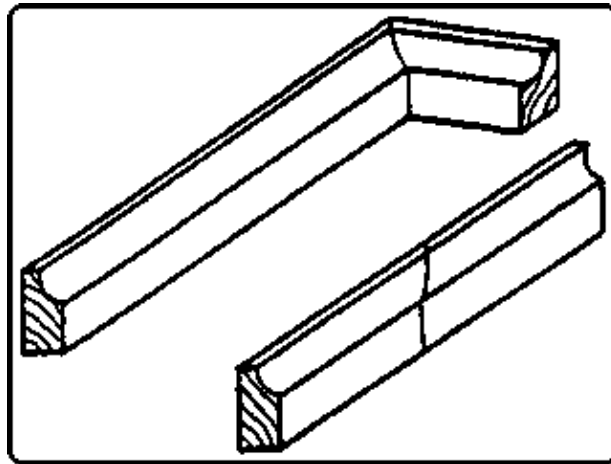

Tools

Hand saw, hammer, chisel, nail punch

Measuring and testing means

Folding rule, try square

Auxiliary accessories

Trestles approximately 600 mm high, mitre box

Required basic knowledge

Measuring, scribing, sawing, nailing, cutting

Sequence of operations	Comments
1. Preparing the workshop place.	
2. Starting work always in reentrant corners, putting the skirting board in the mitre box, cutting mitre inwards with hand saw.	Butt-join the skirting board in the middle of the wall, approximately.
3. Cutting the mitre inwards on the opposite end of the skirting board, too.	
4. Pressing the skirting board firmly to the wall, applying the nail obliquely and nailing the skirting board on the deals.	Skirting boards are fixed at distances of approximately 500–600 mm.

5. Cutting the mitre inwards in the next skirting board for the opposite corner.	
6. Putting the skirting board on the wall, exactly scribing the butt, then cutting mitre outwards and nailing the skirting board on the deals.	
7. With projecting corners cut the reentrant corner first, put the skirting board in place, then scribe the projecting corner and cut the mitre outwards.	If the corners are not accurately right-angled, rework the cut or change the mitre cut. The operations are repeated until the work is finished.
8. Possibly making ventilation slots in the skirting board.	Ventilation of the beam layer with rooms that do not have a cellar.
9. Final checking.	

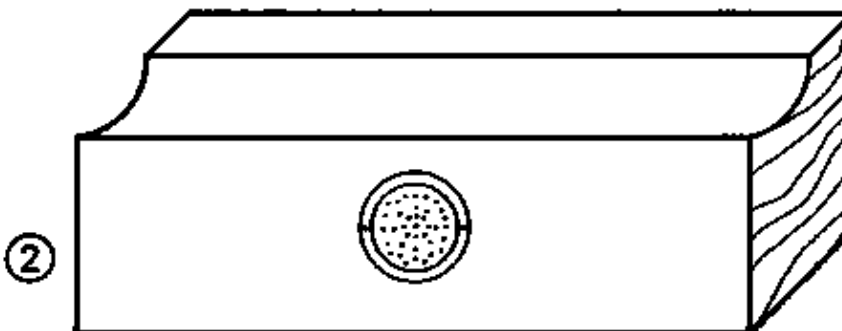
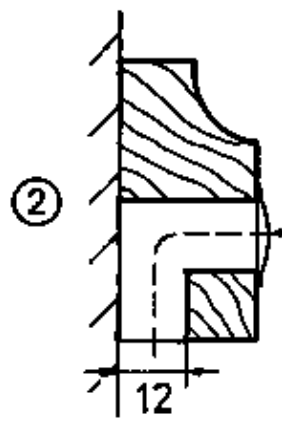
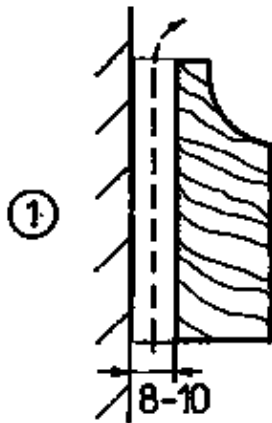
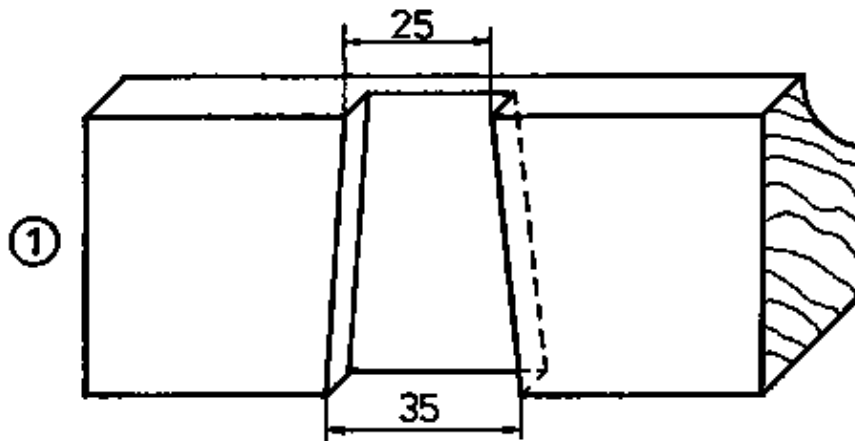

				6.4.
IBE	Skirting boards			3606

Skirting boards