

**Making of Floors – Course: Timberwork techniques. Trainees'
handbook of lessons**

Table of Contents

<u>Making of Floors – Course: Timberwork techniques. Trainees' handbook of lessons</u>	1
1. <u>Task and Quality of Wooden Floors</u>	1
2. <u>Constructive Connections of Surfaced Boards</u>	1
3. <u>Nailing of Surfaced Boards</u>	3
4. <u>Tools and Equipment for Laying Surfaced Boards</u>	4
5. <u>Preparations for Laying Surfaced Boards</u>	4
6. <u>Laying of Surfaced Boards</u>	5
7. <u>Fixing the Skirting Boards</u>	7

Making of Floors – Course: Timberwork techniques. Trainees' handbook of lessons

Institut für berufliche Entwicklung e.V.
Berlin

Original title:
Arbeitsmaterial für den Lernenden
"Herstellen von Fußböden"

Author: Horst Hofmann

First Edition © IBE

Institut für berufliche Entwicklung e.V.
Parkstraße 21/23
13187 Berlin

Order No.: 93–35–3606/2

1. Task and Quality of Wooden Floors

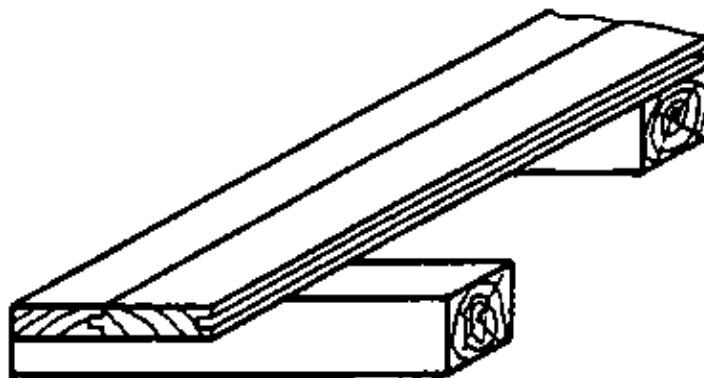

Figure 1

Wooden floors are made from surfaced boards. These shall bridge the spaces between the floor beams or fillets. The surfaced boards form a self-contained horizontal surface which can be well walked on, receive loads and transmit them to the subconstruction.

Surfaced boards shall be of equal thickness, as far as possible of equal parallel width, free from knots and surfaced on one side. They consist of soft wood or hardwood suited for that purpose. They shall be 120 to 160 mm broad and – in surfaced condition – 20 to 24 mm thick. Wooden floors have little dead weight, are relatively elastic and foot-warm. On the other hand, they may be subject to deformation, because wood contracts and expands due to reception of moisture or drying. Wooden floors are easily inflammable, they rot under the influence of moisture and they are susceptible to destructive insects.

What disadvantages do wood floors have?

2. Constructive Connections of Surfaced Boards

– Joint boarding

The boards are connected by straight or inclined joints.

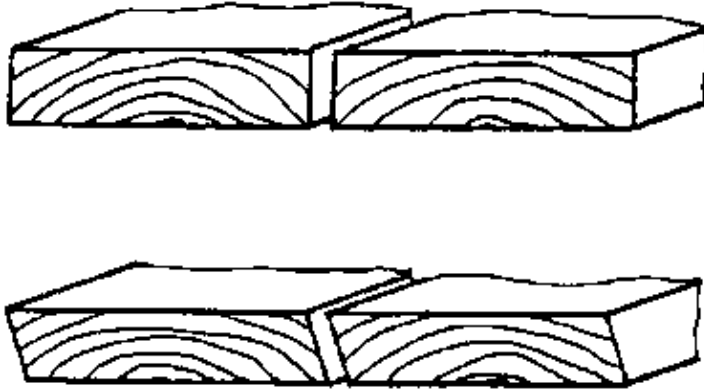

Figure 2

Nailing is open (visible).
Joint boards are used in buildings of less importance.

– Rebated boarding
The boards mate by rebates.

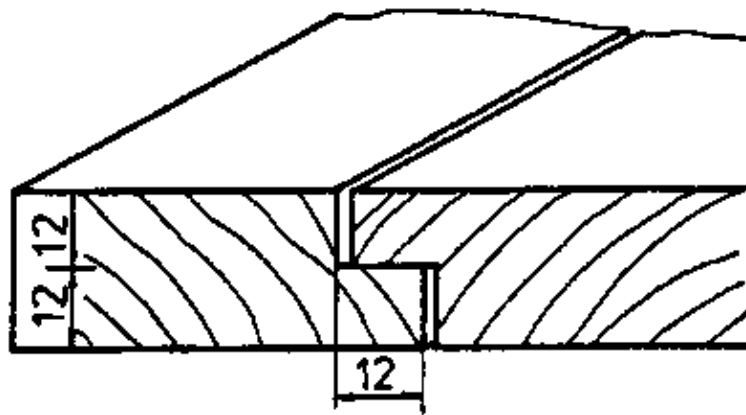

Figure 3

Nailing is open.
Rebated boards are used in buildings of less importance, too.

– Tongued boarding
The boards get grooves on both longitudinal sides in which tongues from wood – hardwood is recommended – or flat irons are shoved.

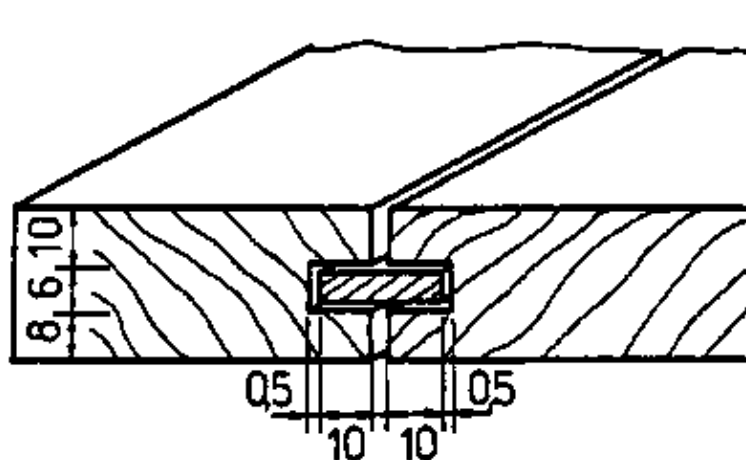
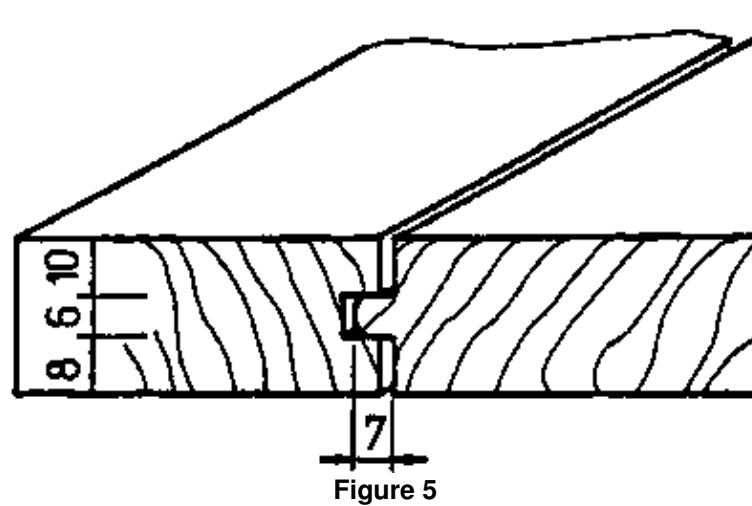

Figure 4

Open nailing is preferred. Covered nailing is possible only in some cases. Tongued boarding can be used in buildings of less importance and in flats.

- Matched boarding
The boards are connected by tongue and groove joints.



This technique provides a solid and dense floor serving many purposes. Open and covered nailing is possible.

Which kind of boarding is the most recommendable one?

3. Nailing of Surfaced Boards

For nailing surfaced boards countersunk head nails should be used. These nails are easier to flush with the surface of the wood. The length of the nails should amount to the triple thickness of the boards, approximately.

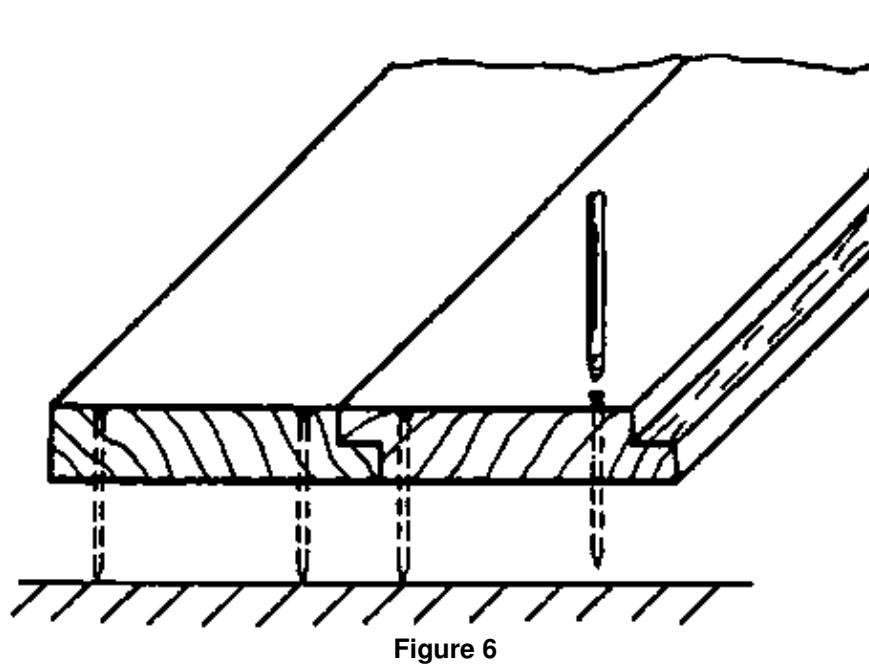

With open nailing – visible – each board is fixed by two nails on each beam.

For covered nailing only matched boarding is suited.

Here, one nail is driven obliquely in the groove and tongue.

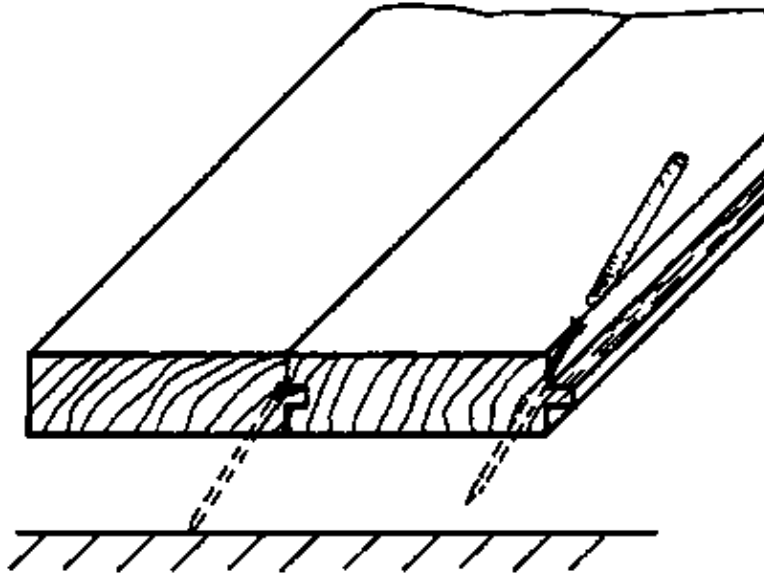

Figure 7

With open, as well as with covered nailing the nails are not completely driven in. Otherwise there is the risk that the surface or, with covered nailing, the groove and tongue and the front edge of the boarding are damaged. The nails are allowed to project 1 to 2 mm; then they are driven in with the help of the nail punch. The hollows in the surface of the boards left by this technique can be puttied up.

When can the technique of covered nailing be used?

4. Tools and Equipment for Laying Surfaced Boards

The following working means are employed:

- Tools
Hand saw, hammer, nail tongs, plane, axe, nail punch.
- Measuring and testing means
Folding rule, iron square, water-level, level board (a plane parallel board).
- Auxiliary accessories
Trestles for supporting the boards, steel clamps for the boards, wedges and pieces of planks.

5. Preparations for Laying Surfaced Boards

The beam systems must be prepared in such way that their surface is plane and horizontal and completely levelled before the boards are laid.

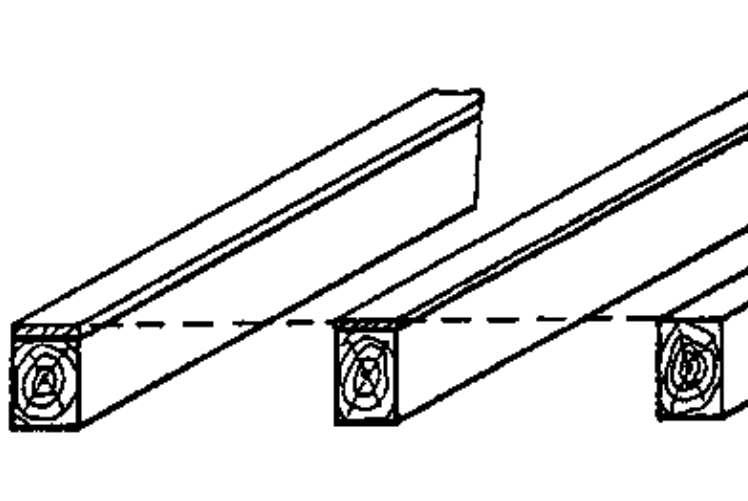

Figure 8

If supporting laths are placed on solid floors, strips of bituminous felt are laid under the laths for protection against moisture.

The supporting laths, too, are laid horizontally. Here, adjustment is achieved by putting short pieces of planks, bituminous felt or other suitable material under them. These backings are closely spaced and across the supporting laths in order to avoid that the laths deflect. Before being laid the supporting laths must be impregnated with a timber preservative for protection against rot.

What has to be considered, if boarding shall be laid on an already existing old layer of beams?

6. Laying of Surfaced Boards

After the preparations are completed and material, tools, measuring and testing means are ready, the following operations have to be started:

- Measuring of the space across the beams.

The determined length, less 20 – 30 mm, if the boards are not butt-jointed, is marked on the boards.

A square is applied to the length marking, the marking is scribed reactangularly and the board is sawn off.

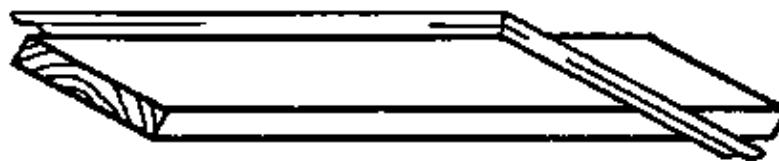

Figure 9

Attention!

Between surfaced boards and abutting fixed parts of a building such as walls or pillars a strip of 10 –15 mm in width has to be left open, which, after the boards are laid, is covered with skirting boards.

Due to the skirting board the wood can better contract and expand. If the boarding absorbs moisture and rises it is not squeezed by the beams.

If matched boards are laid, the tongue is removed from the first board or – with covered nailing – the groove or – in case of rebated boards – the rabbet.

It can be sawn off, chopped off or jacked down. After this, the first board is laid 10–15 mm off the wall and nailed.

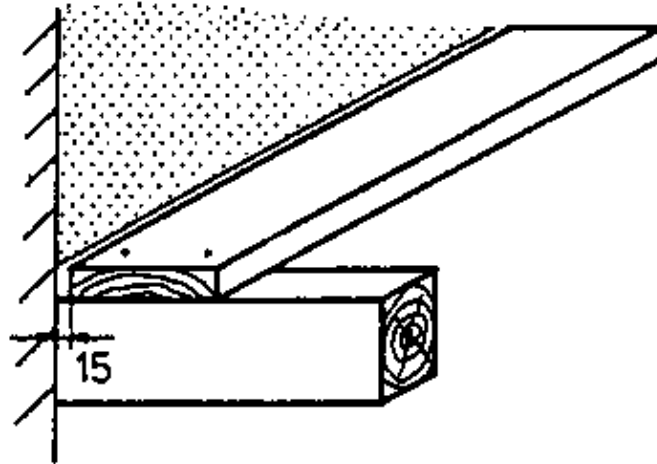

Figure 10

– In front of the first fixed board, another five to six boards are laid loosely and one by one driven together by slight hammer blows. In doing so, a piece of a plank or, which is even better, a piece of a board is placed between the hammer and the respective board to prevent it from being damaged.

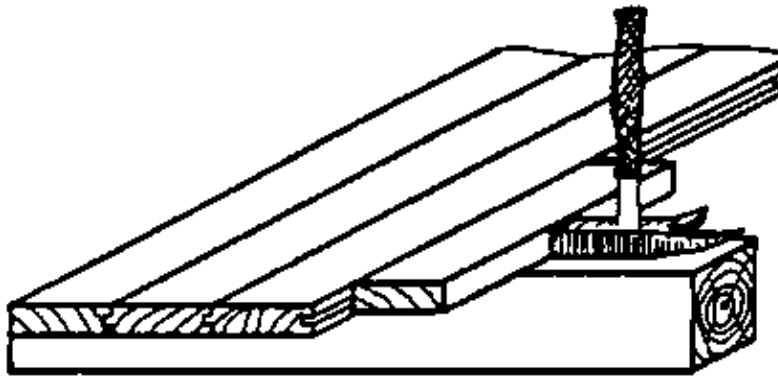

Figure 11

– Next to these deals, deal cramps are fixed on the beams which press the deals closely together. If no such cramps are available, steel cramps – according to the length of the deals – are driven into the beams. A piece of a plank and two wooden wedges are put between the deals and each cramp. Now the wedges are equally fastened with the hammer and thus the deals pressed together closely.

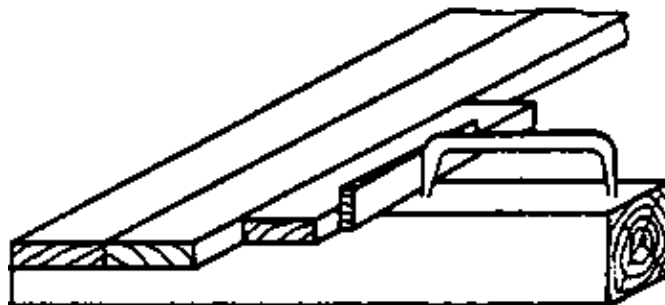

Figure 12

With a pencil a thin nailing line is scribed, and the deals are nailed along this line.

Attention!

With covered nailing, each deal must be driven to the neighbouring one and be nailed immediately. If the deals are butt-jointed, the joint has to be staggered at an interval of 1000

mm, approximately. This helps to distribute loads and vibrations over several beams.

When laying planed boards, the beams have to be covered with planks, so that safe working is possible.

– Putting the last deals in.

With open nailing two to three deals are laid starting from the wall and nailed.

Between these deals and those already laid before, the exact width of two or better four deals must remain free.

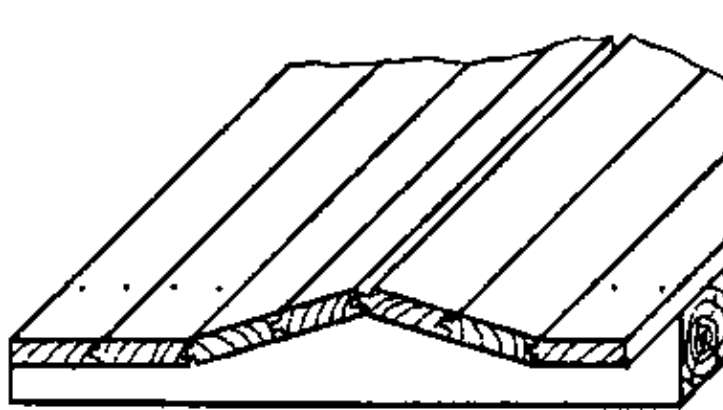

Figure 13

In this interspace the deals to be completed are put in an inclined position from above, so that they show upwards at an obtuse angle. Then, a plank is placed across these deals and one steps on the plank forcing the deals into the interspace by one's weight. With covered nailing, wooden wedges are driven between the last board and the wall until they are close together.

– Levelling of the surface

After all nails are driven in and the deals are cleaned, wood which may be projecting at butt-joints or other places is smoothed with a plane. This way an even, plane surface is reached.

How are deals pressed tightly together?

7. Fixing the Skirting Boards

It is the task of the skirting boards to cover the strip between planed boards and walls. Furthermore, they shall protect the plaster of the walls, the wall paper or painting against damages that might be caused when the floor is cleaned.

Skirting boards are manufactured 40 to 80 mm high and 20 to 30 mm thick and with different profiles according to the requirements.

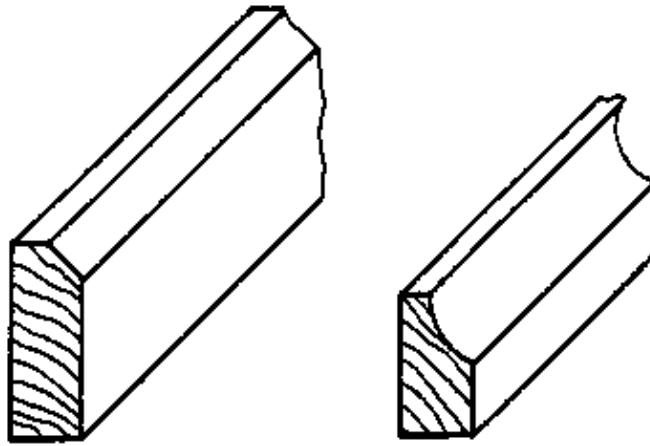

Figure 14

When the skirting boards are fixed, they are butt-joined with a mitre cut (normally 45°) in the reentrant and projecting corners as well as in longitudinal direction.

For these cuts a mitre box is used, which one can make by oneself.

Skirting boards up to 50 mm in height can be nailed on the deals or fixed on the wall with steel nails.

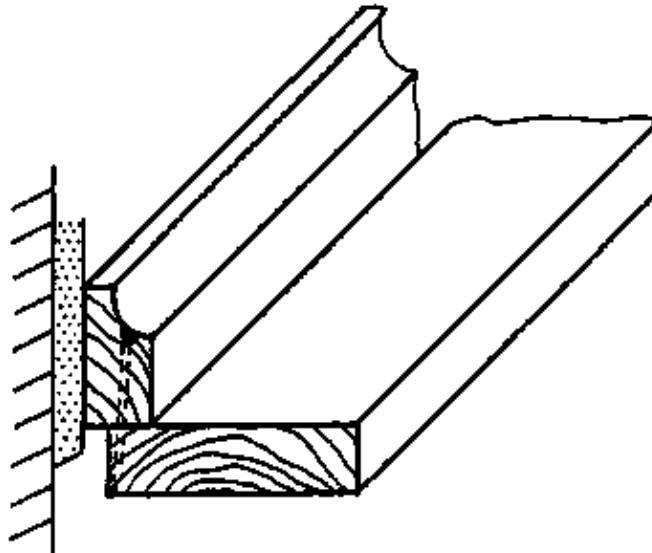

Figure 15

Skirting boards of more than 50 mm in height are fixed on the wall with steel nails or are screwed to previously set plugs or expansion dowels.

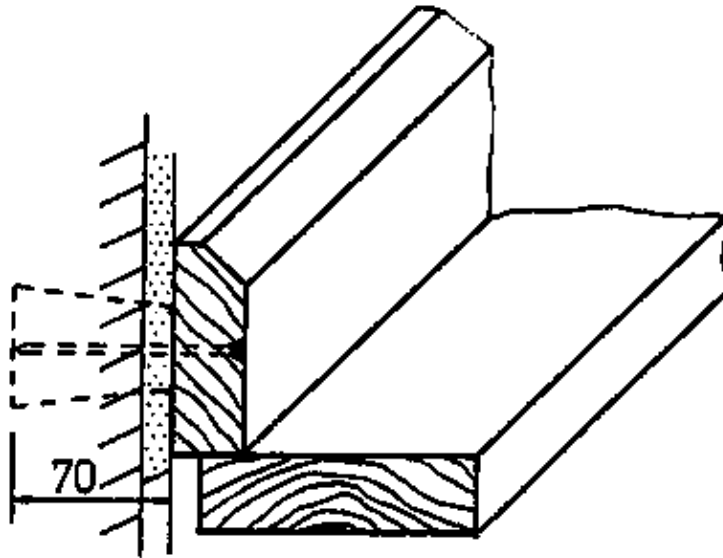

Figure 16

Attention!

The cavities between the beams and/or supporting laths must be ventilated through holes in the cover strips. In rooms without basement good ventilation is absolutely necessary in order to avoid rot at all wooden parts.

How is the skirting board joined in an angular corner?

What must be provided for if there is no cellar under the floor?

What is the last operation after all deals are nailed?
