

**Operations on Wood Turning Lathes – Course: Mechanical  
woodworking techniques. Instruction examples for practical vocational  
training**



# Table of Contents

<b><u>Operations on Wood Turning Lathes – Course: Mechanical woodworking techniques. Instruction examples for practical vocational training</u></b> .....	<b>1</b>
<u>Preliminary Remarks</u> .....	1
<u>Instruction Example 06.1.: Long Trunk Section</u> .....	1
<u>Instruction Example 06.2.: Stool Leg</u> .....	4
<u>Instruction Example 06.3.: Rods for Clothing Holders</u> .....	6
<u>Instruction Example 06.4.: Furniture Knob</u> .....	9
<u>Instruction Example 06.5.: Stool Seat</u> .....	12



# Operations on Wood Turning Lathes – Course: Mechanical woodworking techniques. Instruction examples for practical vocational training

Institut für berufliche Entwicklung e.V.  
Berlin

Original title:  
Lehrbeispiele für die berufspraktische Ausbildung  
“Arbeiten an Holzdrehmaschinen”

Author: Günter Hanisch

First Edition © IBE

Institut für berufliche Entwicklung e.V.  
Parkstraße 23  
13187 Berlin

Order No.: 93–33–3406/2

## Preliminary Remarks

This material features five selected instruction examples for turning long trunks and cross pieces.

The necessary materials and tools, measuring and testing means, equally aids have been cited in each case to facilitate preparations and exercises. Preliminary knowledge required for the instruction examples has also been detailed.

The exercises may be undertaken independently utilising the workshop drawings and the commensurate work sequences.

Exercises have been selected as Instruction Examples which, upon completion, yield usable objects resp. can be combined with other elements into small piece of furniture and other bigger items.

## Instruction Example 06.1.: Long Trunk Section

Bent turning of squared wood to yield a cylindrical workpiece as necessary preliminary operation for many turning jobs.

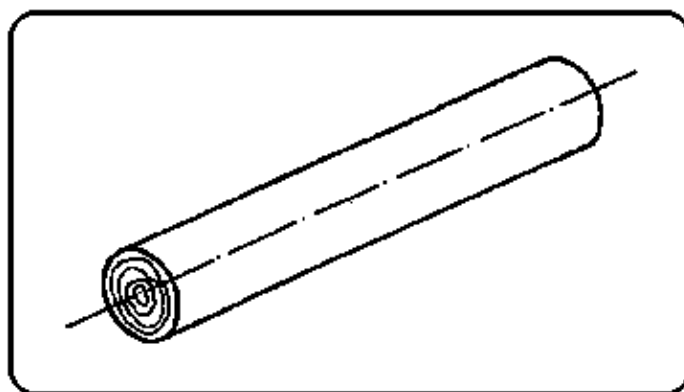

### Material

Hard wood piece, squared 45 x 45 mm length: 450 mm grain ends rectangular, cut

## Machines and tools

Wood turning lathe, broad roughing tool, straight planer, chucking facility, driving tongue (trifurcate) 30 mm

## Measuring and testing means

Folding rule, caliper or vernier caliper

## Auxiliary accessories

Pencil, punch mark, hammer

## Necessary preliminary knowledge

Assembly and function of a wood turning lathe.  
Labour safety provisions when operating a wood turning lathe.  
Chucking processes for wood turning.  
Read drawings, marking, measuring and checking.

## Explanation of workshop drawing

Scale 1:1

Sequence of operations	Comments
1. Position work materials and check machine for proper operating condition.	Check completeness of work materials, sharpness of tools and cleanliness of the machine.
2. Mark the chucking points on the workpiece.	Determine the centre point at the grain ends by marking the diagonals.
3. Punch–mark the centre point.	Only punch–mark the centre point slightly on the drive side.
4. Link up the workpiece to the trifurcate.	By turning the spindle bring the trifurcate to horizontale position, place the trifurcate laterally to the annual rings of the wood.
5. Position tailstock with tailstock centre to the right workpiece end and, employing slight pressure, arrest to the workpiece.	Apply a few drops of oil to the tailstock centre without ball bearings.
6. Attach the support strip a few mm above the centre line of the workpiece in working position.	Check the unimpeded running of the workpiece.
7. Set the machine gears to a rotational speed of 2000 min <sup>-1</sup> .	Thereby, at the same time again check the functional safety of the machine.
8. Switch on the machine.	
9. Turning with roughing tool. Proceed slowly and carefully to within 3 mm of the finished size pertaining to the length dependent on the support strip.	<i>Work carefully with minimal chip removal and grip tool firmly. Turning down the workpiece edges causes blows to the tool – accident danger!</i>
10. Switch off the machine, check size, reset the support strip for further workpiece processing and switch on the machine. Repeat the turning operation. This operation is repeated until the entire workpiece length has been worked.	Heed the hints on “Joining by twisting” in the Trainees’ Handbook of Lessons.
11. Attach the support strip 2 mm above the workpiece centre line and 2 mm from the workpiece.	
12. Turning with flat planer.	

	Process the workpiece surface carefully along the length of the support strip with minimal chip removal. Thereby determine the most favourable angle between tool and workpiece.
13. Size control with caliper or vernier caliper.	Switch off the machine for size control!
14. Reposition the support strip. Repeat turning and size control until the workpiece has been uniformly processed along its entire length.	When turning ensure minimal chip removal. Always turn from the thicker to the thinner workpiece section.
15. Size control and processing quality checking.	
16. Unchuck workpiece from machine. Remove turning chips from machine.	

**Possible additions**

Turning further like sized workpieces. (The workpiece from this Instruction Example is processed further in the 2. Instruction Example into a stool leg.)

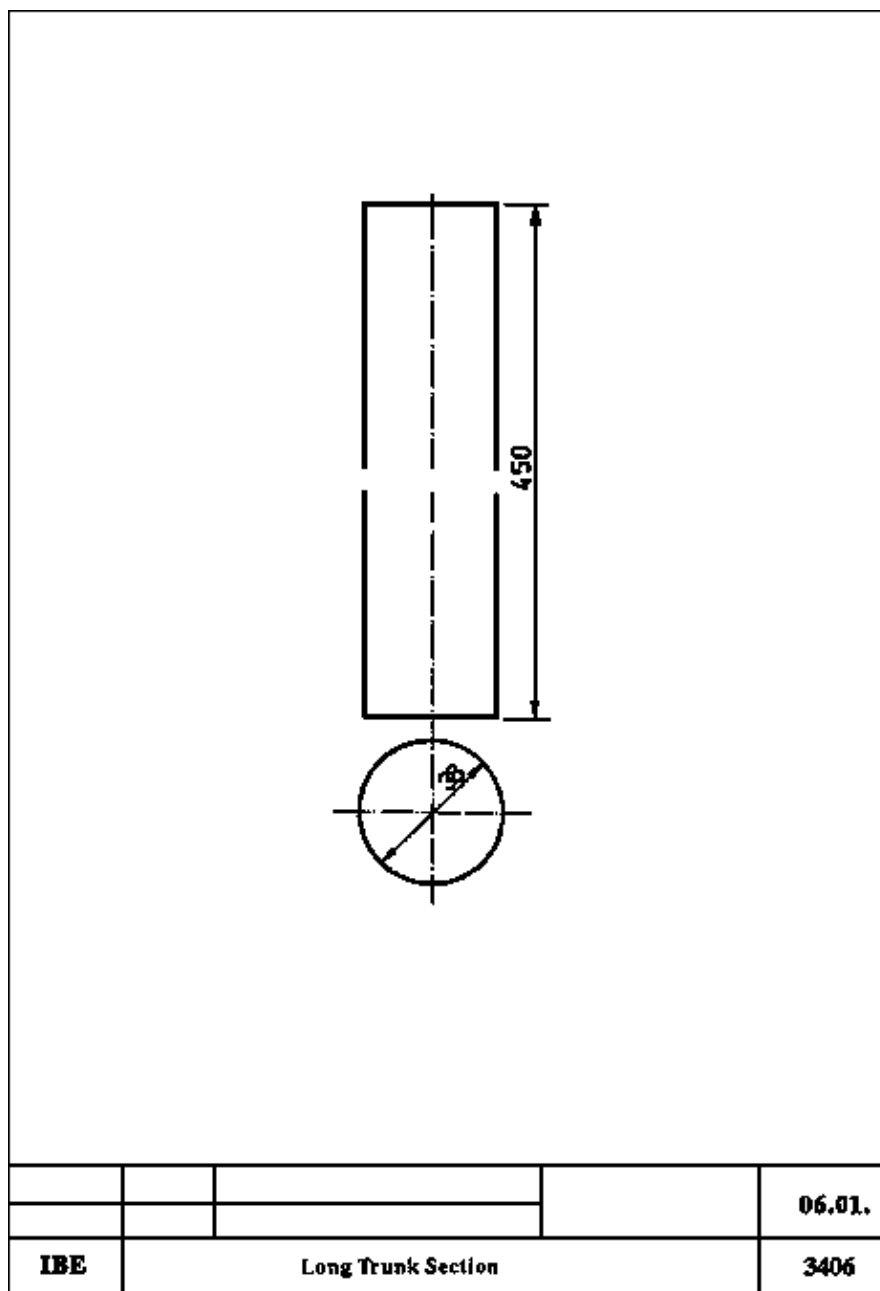

## Instruction Example 06.2.: Stool Leg

A stool leg is made from the long trunk piece turned in Instruction Example 06.1.

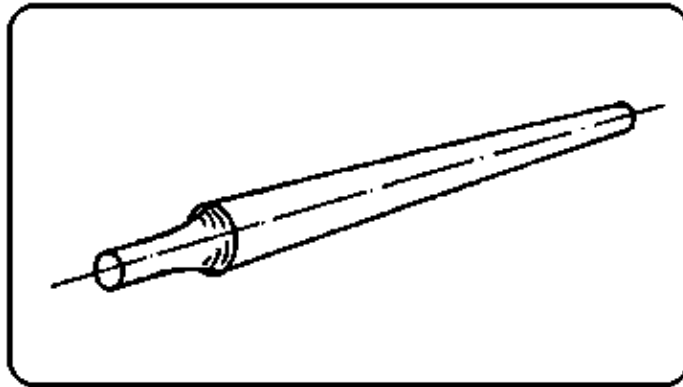

### Material

Round wood (hard wood)  
diameter: 38 mm  
length: 450 mm  
(workpiece from first instruction example)

### Machines and tools

Wood turning lathe, straight planer, wide forming tool, chucking facility: trifurcate

### Measuring and testing means

Folding rule, caliper or vernier caliper

### Auxiliary accessories

Pencil, hammer, medium–fine abrasive paper

### Necessary preliminary knowledge

Assembly and function of a wood turning lathe.  
Labour safety provisions when operating a wood turning lathe.  
Chuck long trunk workpiece and set up the machine.  
Chucking processes when turning wood.  
Read drawing, marking, measuring and testing.

Sequence of operations	Comments
1. Position the work materials and check machine for proper operating condition.	Check completeness of work materials, sharpness of tools and cleanliness of the machine.
2. Chuck the workpiece.	Engage the trifurcate and tailstock centre in the existing workpiece impressions. Only strike round wood lightly at the plugging chisel.
3. Support strip positioned and firmly chucked at left workpiece end (approx. 3 mm above the workpiece centre line 2 mm distant from the workpiece).	Check the round and unimpeded workpiece running by means of manual turning.
4. Set the machine gears to a rotational speed of 2000 min <sup>-1</sup> .	Recheck proper machine function.



5. Mark the tenon length = 70 mm on the left workpiece end.	Mark size with pencil in workpiece, position pencil again on the fissure and position on support strip. By turning the workpiece by hand the pencil fissure is transferred to the workpiece circumference.
6. Switch on the machine.	
7. Join chamfer by twisting and the tenon to the wide forming tool.  Pay attention!  If the tenon size is not heeded the tool can touch the trifurcate. – Danger of accidents. Tool and machine damage unavoidable.	On the left workpiece end join a chamfer by twisting to a tenon thickness = 32 mm. Then by means of repeated further turning displace to fissure on the right. Do not fall below the tenon size!
8. Switch off the machine, size control and position the stop strip to the right workpiece end.	Size correction by repeated further turning possible given oversize.
9. Switch on the machine and, using a straight planer, turn down workpiece slightly cone-like to a diameter = 25 mm.	Always turn down from the thicker to the thinner workpiece end. Check inclination by rule at the conical leg.
10. Join chamfer by twisting.	
11. Position the support strip anew according to workpiece length and repeat turning operation until the leg is 37 mm from the tenon chamfer = 25 mm thus evidencing a uniform degree of taper.	Switch off machine whilst measuring and checking the workpiece.
12. Grind the workpiece surface with abrasive paper whilst machine is running.	Only grind the tenon slightly otherwise undersize results.  Pay attention!  Abrasive paper must not wind itself around the workpiece. Danger of accidents!
13. Switch off the machine, check processing quality.	
14. Unchuck workpiece from the machine, clean the machine.	

#### **Possible additions**

Turning out more stool legs.

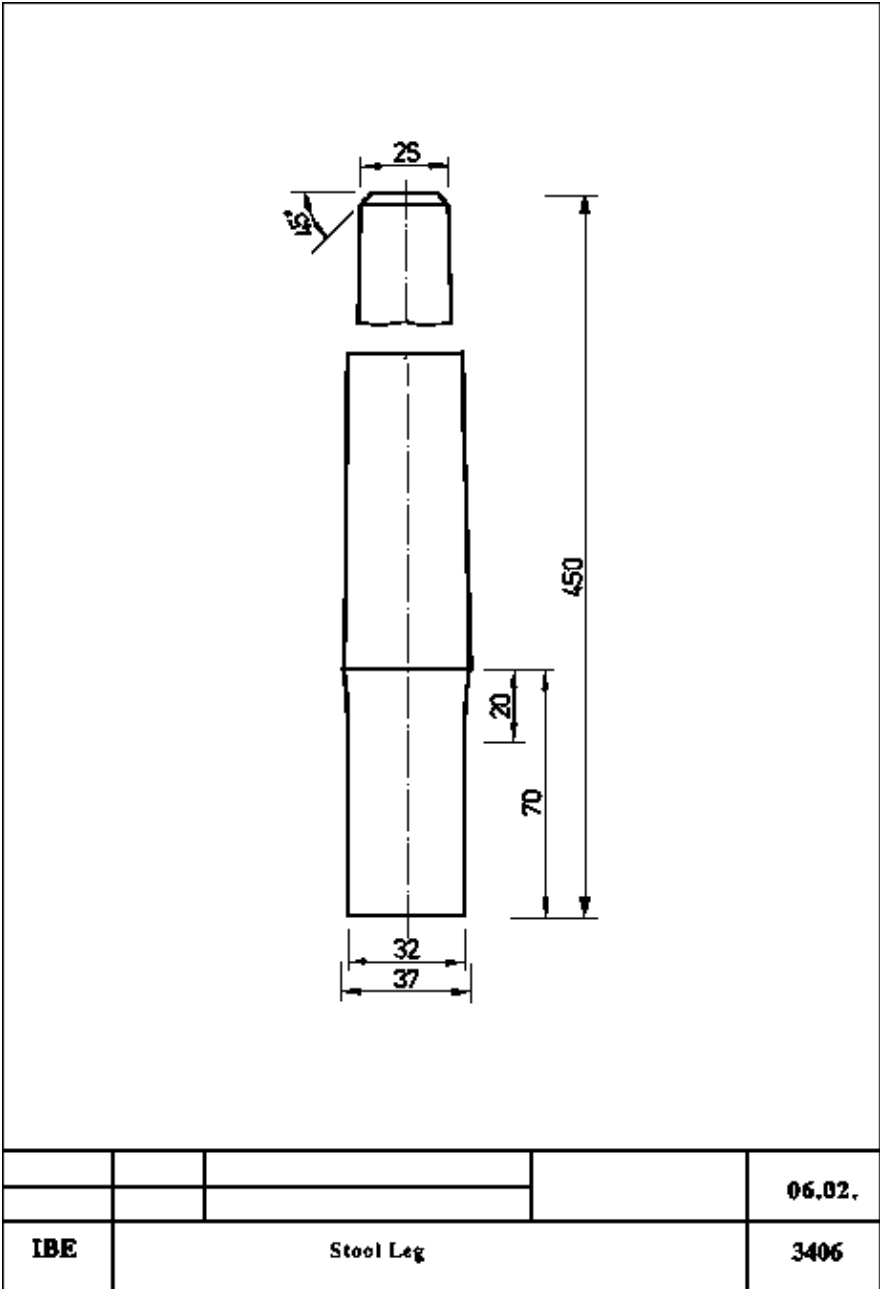

**Instruction Example 06.3.: Rods for Clothing Holders**

Rods for clothing holders stem from form turning according to a templet. Two rods are turned from one work-piece and subsequently separated.

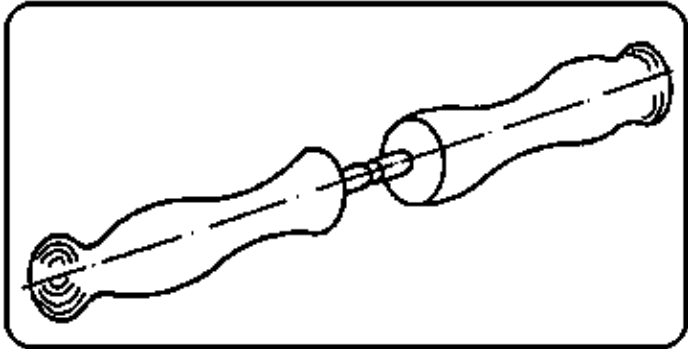

**Material**

Squared wood, machine finished  
35 mm x 35 mm, 270 mm long

### Machines and tools

Wood turning lathe, roughing Tool, wide forming tool, narrow forming tool, straight planer, cutting tool, fine saw, chucking means: small trifurcate

### Measuring and testing means

Folding rule, caliper or vernier caliper, templet

### Auxiliary accessories

Pencil, hammer, medium–fine abrasive paper, punch mark

### Necessary preliminary knowledge

Assembly and function of a wood turning lathe. Labour safety provisions when operating a wood tuning lathe. Chuck workpiece and set up machine. Cutting processes when turning wood. Experience in handling turning tools. Read drawings, marking, measuring and testing.

### Necessary work preparations

Prepare a templet of drawing cardboard or thin carton according to works drawing.

Mark the centre points of the squared wood and punch mark, subsequently, by planing off, yield eight instead of previously four edges.

Sequence of operations	Comments
1. Position the work materials and check machine for proper working condition.	Check completeness of work materials, sharpness of tools and cleanliness of machine.
2. Punch mark the workpiece and chuck into the machine.	Do not chuck too tightly otherwise the workpiece splits.
3. Position the support strip and check unimpeded running of the machine.	Strip top edge about 3 mm above the workpiece centre line.
4. Round turning of workpiece with roughing tool. Reset support strip.	Turn workpiece uniformly to 31 mm diameter (final measure + 1 mm processing addition).
5. Mark workpiece according to paper templet.	Begin at the right hand workpiece end with a 2 mm processing addition, mark the three highest profile points and the tenon length by means of circulating workpiece fissure, turn templet and mark left hand workpiece part.
6. Turn the extended partial profile in the middle section of the workpiece using the wide roughing tool.	Commence at the deepest profile point by alternate turning in, always turn from the thick to the thin workpiece section. Hold templet behind workpiece when checking. The pencil fissures should remain visible if possible.
7. Roughly pre–turn both tenons with the narrow roughing tool.	Slightly undercut the tenon shoulder when turning.
8. Finish cut tenon with straight planer and turn in notch at the tenon ends (2 x 45°).	Adhere precisely to tenon thickness of 20 mm!
9. Turn the knob at the workpiece end using the narrow forming tool, begin at the right.	Pay attention!

	Leave some 20 mm round wood at the left workpiece end, a workpiece core of some 10 mm remains.
10. Machine–finish the curves and the flat chamfer with the straight planer.	If possible, remove chips whilst cutting, check shape and knob diameter = 28 mm according to templet.
11. Grind workpiece with medium–fine abrasive paper.	Do not change the shape when grinding. Do not grind tenons.
12. Complete turning of right knob by means of the cutting tool, extending towards the tailstock centre.	
13. Cut workpiece at left knob.	
14 Separate the workpiece parts in the notch using a fine saw.	
15. Quality control and chip removal from machine.	Manually regrind the knobs at the cutting point.

**Possible additions**

Turning out further rods for clothing holders.

			06.03.
<b>IBE</b>	<b>Rods for Clothing Holders</b>		<b>3406</b>

### Instruction Example 06.4.: Furniture Knob

Turning a hard wood piece to yield a furniture knob

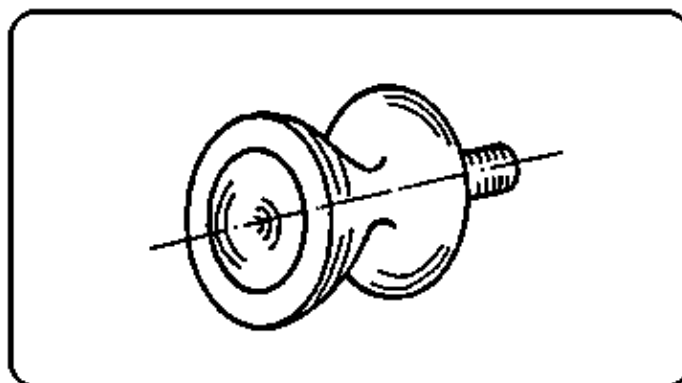

**Material**

Hard wood, approx. 500 mm long  
 cross-section: 50 x 50  
 round turning and sawing to length as preliminary operations

**Machines and tools**

Wood turning lathe, small forming tool, small and straight planer, finishing tool, chucking facility, three-jaw chuck

**Measuring and testing means**

Folding rule, caliper or vernier caliper, paper templet

**Auxiliary accessories**

Pencil, medium-fine abrasive paper

**Necessary preliminary knowledge**

Assembly and function of a wood turning lathe. Labour safety provision when operating a wood turning lathe. Chuck workpiece and set up machine. Chucking processes when undertaking wood turning. Experience in handling turning tools. Reading drawings, marking, measuring and testing.

**Necessary work preparations**

Round turning of workpiece as described in Instruction Example 06.1. Diameter = 48 mm.

The round piece is cut into 60 mm long rolls using a hand or belt saw (ensure rectangular cuts).

Prepare a templet of the side profile of the furniture knob on drawing carton or thin cardboard according to works drawing.

Sequence of operations	Comments
1. Position work materials and check machine for proper working condition.	Check completeness of work materials, sharpness of tools and cleanliness of machine.
2. Reset the machine. Screw on three-jaw chuck. Employ external jaws!	Only necessary when switching from round turning to turning the furniture knobs.
3. Chuck workpiece into clamp.	Check the uniform running of the workpiece. Align chucking forces to wood hardness.
4. Position the support strip to workpiece end face.	5 mm below the centre line.
5. Use finishing tool to surface the workpiece end faces.	Only minimal cut with scraping tool motion.
6. Mark handle diameter by means of pencil fissure = 23 mm from the centre point. Mark the 5 mm board with a pencil.	
7. Turn the flat chamfer with the small forming tool.	Constant grain sequence changes, therefore only minimal chip removal to be undertaken.
8. Reposition the support strip.	Support strip parallel to rotational axis, some 3 mm above the centre line.
9. Turn the side profile with the small forming tool – diameter = 46 mm – turn after fissure at the end face – diameter = 38 mm join by twisting	Setting out from both diameters turn the profile reciprocally into the depth. Check with templet.

– profile turning.	
10. Preturn tenon with small forming tool and finish cut with small, straight planer.	Pay attention! Retain sufficient distance to chucking jaws. Danger of accidents. Do not fall below the tenon size.
11. Notch in a groove with the planer given a 13 mm tenon length.	
12. Grind the workpiece.	Workpiece edges at the end faces must not be ground round, otherwise the visual effect of the profile is lost.
13. Cut the workpiece in the tenon notch.	
14. Quality control and remove chips from machine.	

### Possible additions

Turn further furniture knobs. Similar handles in different forms and other dimensions can also be turned according to a new drawing.

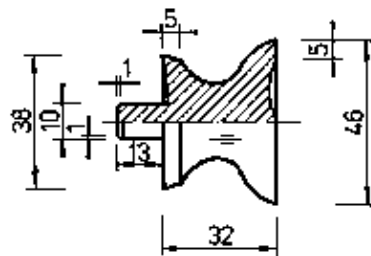

				06.04.
<b>IBE</b>	<b>Furniture Knob</b>			<b>3406</b>

## Instruction Example 06.5.: Stool Seat

A stool seat results from machine-finishing and rounding off the edges of a hard wood seat.

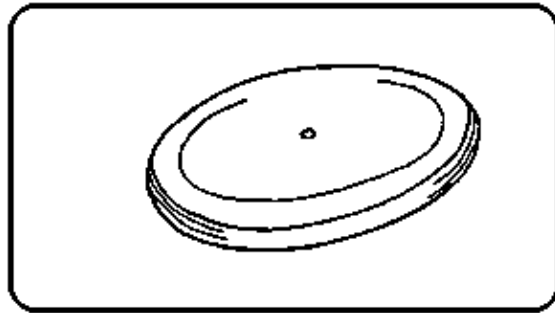

### Material

Hard wood seat = 24 mm thick  
diameter = 380 mm

### Machines and tools

Wood turning lathe, big forming tool, finishing tool, screwdriver, 4 mm gimlet, chucking facility, big driving plate

### Measuring and testing means

Folding rule, ruler (wood) 400 mm

### Auxiliary accessories

Abrasive paper, pencil, four wood screws (4 x 20 mm cheese-head)

### Necessary preliminary knowledge

Sound skills and expertise in handling turning tools on the turning lathe. Knowledge of all necessary labour safety measures. Reading drawing, measuring and testing.

### Necessary work preparations

A stool plate is required as flat workpiece glued from hard wood to a thickness of 25 mm measuring 400 x 400 mm. Subsequently, after the centre point has been marked on the lower seat side, a circular seat is marked and sawn out with the band sawing machine. Further processing ensues on the wood turning lathe.

Sequence of operations	Comments
1. Position work materials and check machine for proper working order.	Check completeness of work materials, sharpness of tools and cleanliness of machine.
2. Mark a penciled rectangular cross at the centre point on the lower plate side.	Seat grain sequence must run diagonally to the marked cross (seat can more easily be chucked flat).
3. Driving plate is attached centrally by four wood screws to the workpiece.	Pre-drill screw holes with a gimlet.
4. Attach driving plate with workpiece to the spindle of the wood turning lathe.	
5. Position support strip to the front radius of the workpiece wide face.	Support strip is about 4 mm below the centre line some 10 mm from the workpiece. During turning the tool cutter must strike the centre of rotation.



6. Check the unimpeded and central running of workpiece.	
7. Set a slow spindle speed and carefully face the surface using a finishing tool.	Pay attention! The spindle speed is too low for the plate centre but still too great for the seat edge. Be careful at seat edge.
8. Turn out the hollow of the seating surface with a big forming tube.	Size control: measure the size of the seating surface.
9. Turn the curve at the plate edge by means of the forming tool.	Pay attention! Only with minimal chip removal for the speed is unfavourably high for the circumference.
10. Cut the narrow face by means of the finishing tool vertically to the wide surface.	Use the finishing tool as for surfacing. Subsequently re-work the curve.
11. Grind the workpiece.	
12. Check quality, unchuck the workpiece and remove chips from the machine.	

