

[Home](#) > [ar.cn.de.en.es.fr.id.it.ph.po.ru.sw](#)

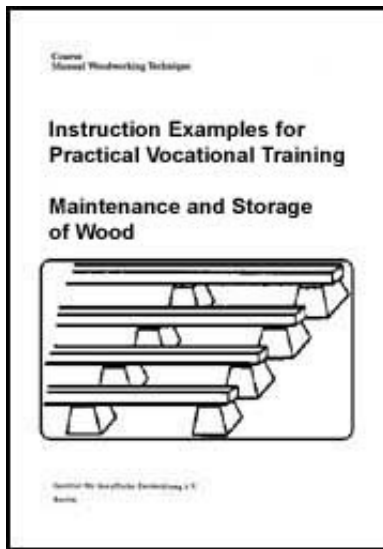

➔ **Maintenance and Storage of Wood - Course: Manual woodworking techniques. Instruction examples for practical vocational training (Institut fr Berufliche Entwicklung, 15 p.)**

- 📄 **(introduction...)**
- 📄 **Preliminary Remarks**
- 📄 **Instruction Example 8.1.: Sawn Timber Storage Yard**
- 📄 **Instruction Example 8.2.: Box-type Pile**
- 📄 **Instruction Example 8.3.: Double-block Pile**



[Home](#) > [ar.cn.de.en.es.fr.id.it.ph.po.ru.sw](#)

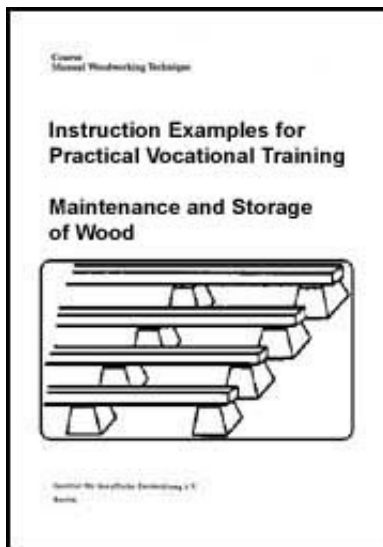

📖 **Maintenance and Storage of Wood - Course: Manual woodworking techniques. Instruction examples for practical vocational training (Institut fr Berufliche Entwicklung, 15 p.)**

- ➔ 📄 **(introduction...)**
- 📄 **Preliminary Remarks**
- 📄 **Instruction Example 8.1.: Sawn Timber Storage Yard**
- 📄 **Instruction Example 8.2.: Box-type Pile**
- 📄 **Instruction Example 8.3.: Double-block Pile**

**Institut fr berufliche Entwicklung e.V.
Berlin**

Original title:

**Lehrbeispiele fr die berufspraktische Ausbildung
"Holzpflege und Holzlagerung"**

Author: Rolf Jakoby

First edition © IBE

**Institut fr berufliche Entwicklung e.V.
Parkstrae 23
13187 Berlin**

Order No.: 93-33-3308/2



[Home](#) > [ar](#).[cn](#).[de](#).[en](#).[es](#).[fr](#).[id](#).[it](#).[ph](#).[po](#).[ru](#).[sw](#)







**Maintenance and Storage of Wood - Course: Manual
woodworking techniques. Instruction examples for
practical vocational training (Institut fr Berufliche
Entwicklung, 15 p.)**

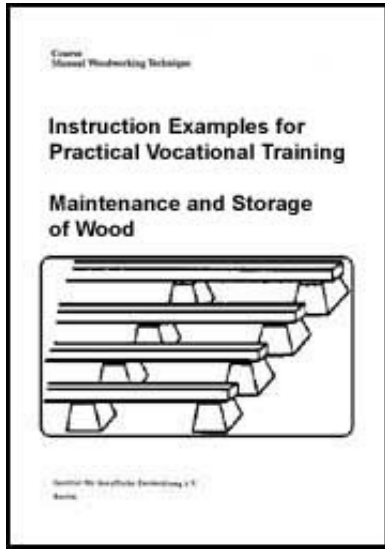

(introduction...)



- ➔  **Preliminary Remarks**
-  **Instruction Example 8.1.: Sawn Timber Storage Yard**
-  **Instruction Example 8.2.: Box-type Pile**
-  **Instruction Example 8.3.: Double-block Pile**

Preliminary Remarks

The present booklet contains 3 selected instruction examples to acquire the necessary knowledge and skills for the maintenance and storage of wood.

These particular examples are preferably intended for application of the manual technique of natural open-air drying of wood. But with slight modifications, the examples 2 and 3 can also be used for technical drying of wood in drying kilns.

For each example, the necessary materials, tools, measuring and testing means, auxiliary accessories and previous knowledge of the trainees are specified to facilitate the preparation and execution of the work.

The sequence of operations given for each example contains the order of working steps leading to the correct completion of the task. Peculiarities of craftsmanship are pointed out. A working drawing showing the recommended sizes is attached to each instruction example for better understanding of the task. Depending on the

local and climatic conditions at the timber yard as well as on specific properties and dimensions of the wood to be stored, modifications thereto can be made by the instructor.



[Home](#) > [ar](#).[cn](#).[de](#).[en](#).[es](#).[fr](#).[id](#).[it](#).[ph](#).[po](#).[ru](#).[sw](#)

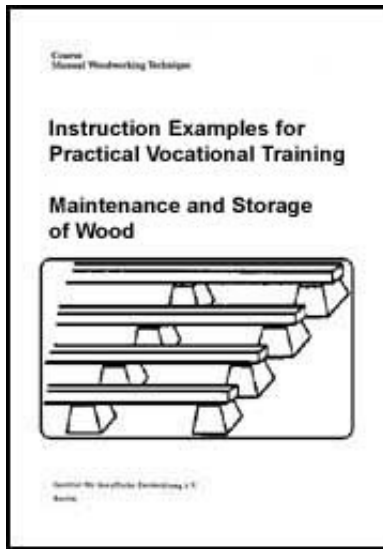

 **Maintenance and Storage of Wood - Course: Manual woodworking techniques. Instruction examples for practical vocational training (Institut fr Berufliche Entwicklung, 15 p.)**

 **(introduction...)**

 **Preliminary Remarks**

 **➔ Instruction Example 8.1.: Sawn Timber Storage Yard**

 **Instruction Example 8.2.: Box-type Pile**

 **Instruction Example 8.3.: Double-block Pile**

Instruction Example 8.1.: Sawn Timber Storage Yard

This example serves to practise the preparation of a storage yard for sawn timber for natural open-air drying of the piled up wood.

Material

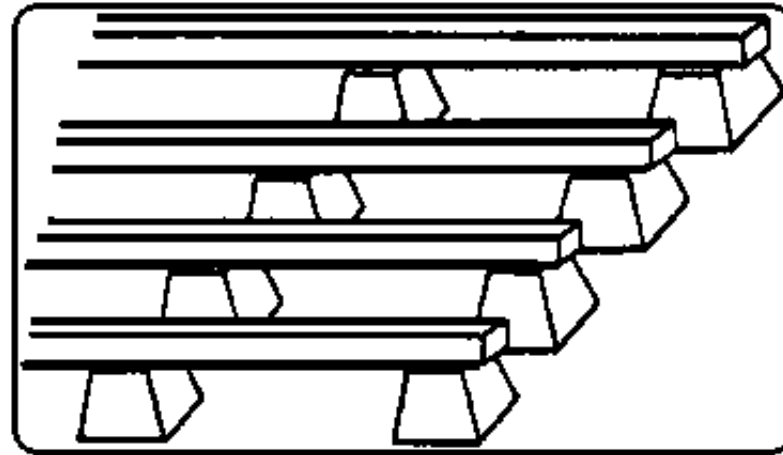

Figure

Pile stones of concrete or natural stone

Dimensions:

Width: at least 400 mm

Length: at least 400 mm

Height: at least 300 mm

Squared timbers (impregnated with preservatives)

Dimensions:

Width: at least 100 mm

Length: at least 1000 mm

Thickness: at least 100 mm

Tools

If necessary, earthwork too Is like pick, shovel, spade, hoe

Measuring and testing means

Measuring tape, folding or solid rule, long straightedge, water level, stretching line

Necessary previous knowledge

Types of wood, properties of wood, measuring, testing

Sequence of operations	Comments
1. Decide on the location of the sawn timber storage yard.	Take into account the necessary distances to neighbouring premises and the main wind direction.
2. If necessary, clean the yard to remove dirt, wood and bark waste.	
3. Plane the yard (if necessary).	
4. Lay out the pile stones on the yard with equal length and width distances.	Make sure that the centre-to-centre distance are correct with respect to the dimensions and type (different weights) of the wood to be stored.
5. Check the position of the pile stones for horizontal position and alignment in height as well as straightness in length and width by means of long straightedge or stretching line and water level.	Put the straightedge on the pile stones in longitudinal and transverse directions and compare or tightly stretch the line over the pile stones and compare. Put water level on the straightedge or hold it at the line.
6. If necessary, change the position of the	Adjust the height alignment of the pile stones

pile stones until the required position as per 5. above is achieved.	by adding or removing soil on the yard.
7. Put the squared timbers on the aligned pile stones in a straight line and in parallel with each other.	The longitudinal grain direction to be in main wind direction.
8. Check the position of the squared timbers as per steps 5. and 6. above.	Similarly take into account the comments on steps 5. and 6. above.

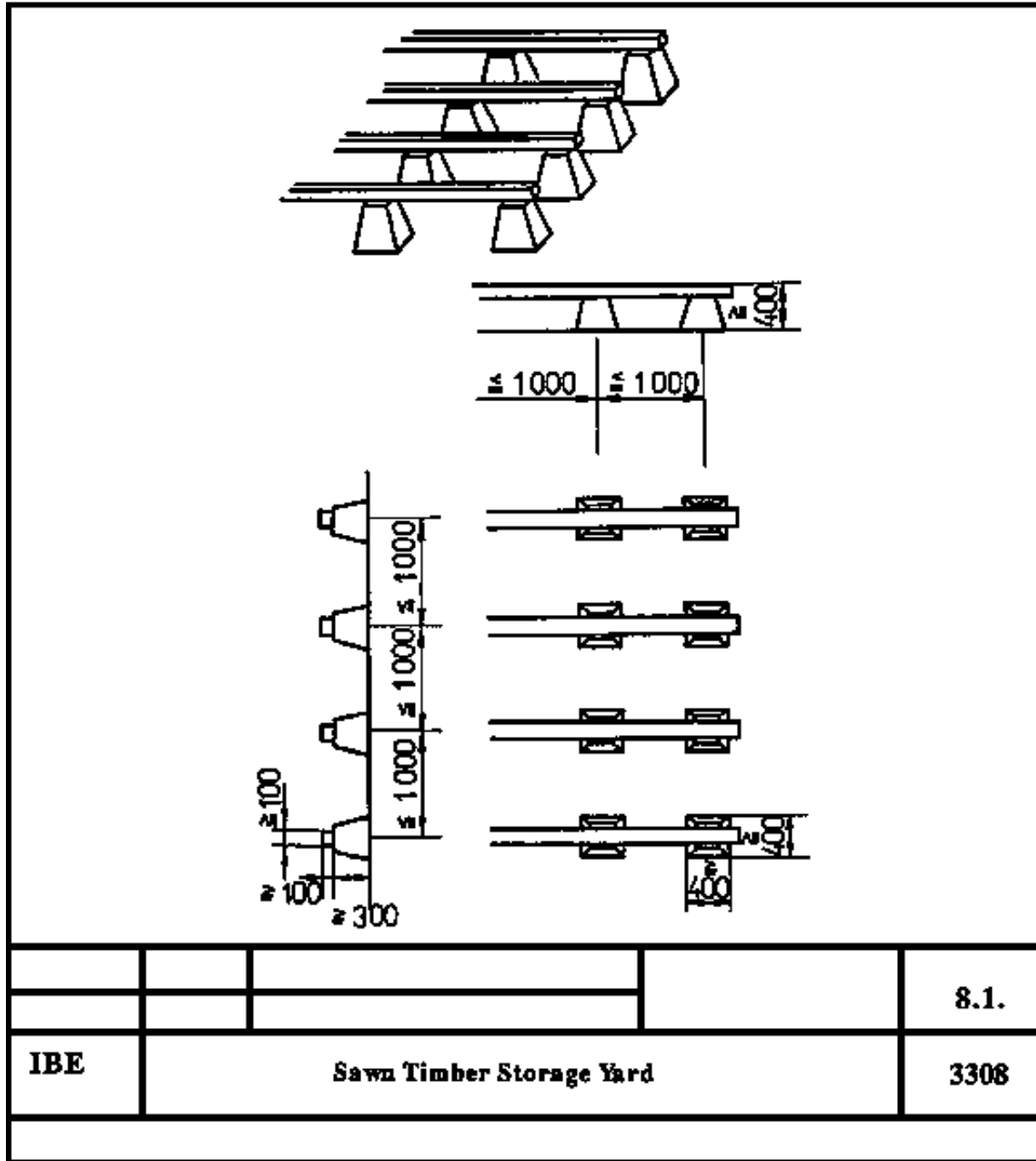

				8.1.
IBE	Sawn Timber Storage Yard			3308

Sawn Timber Storage Yard



[Home](#) > [ar](#).[cn](#).[de](#).[en](#).[es](#).[fr](#).[id](#).[it](#).[ph](#).[po](#).[ru](#).[sw](#)



 **Maintenance and Storage of Wood - Course: Manual woodworking techniques. Instruction examples for practical vocational training (Institut fr Berufliche Entwicklung, 15 p.)**

 **(*introduction...*)**

 **Preliminary Remarks**

 **Instruction Example 8.1.: Sawn Timber Storage Yard**

 **➔ Instruction Example 8.2.: Box-type Pile**

 **Instruction Example 8.3.: Double-block Pile**

Instruction Example 8.2.: Box-type Pile

This example serves to practise the construction of a box-type pile. Box-type piles are applied for sawn timber sorted boardwise or blockwise.

Material

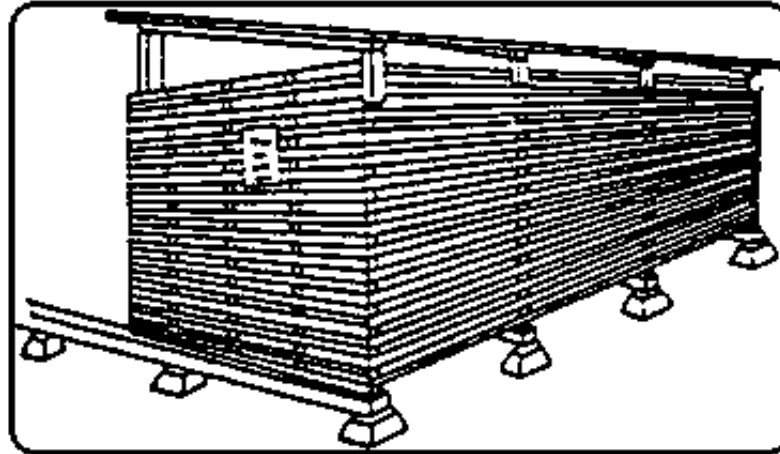

Figure

Non-edged or edged boards

Dimensions:

Width: as available

Length: at least 2000 mm

Equal thickness: at least 25 mm

Tools

Metal hammer 250 to 500 g

Measuring and testing means

Measuring tape or folding rule, long straightedge, stretching line, water level

Auxiliary accessories

Pile strips (width: 25 mm to 50 mm)

Dimensions:

Width: 25 mm to 50 mm

Length: at least 1000 mm

Thickness: at least 25 mm

Ladder (scaffold), covering plates, identification plate, nails

Necessary previous knowledge

Types of wood, properties of wood, measuring, testing, preparation of a sawn timber storage yard

Sequence of operations	Comments
1. Check the prepared timber yard and pile base for meeting of requirements.	Check the position of the pile stones for joint horizontal and aligned height and for straight-ness in length and width by means of long straightedge or stretching line with water level. If necessary, adjust the position of the pile stones until the required position is achieved.
2. Put pile strips longitudinally on the squared timbers of the pile base.	The grains of the squared timbers and of the pile strips to have the same direction. Put one pile strip on each squared timber. Make sure that the pile strips have the same thickness.
3. Put several boards	The faces of the boards nearer to the heart to show upwards.

side by side and transversely on the pile strips until the intended pile width is reached.	Always let the edges of one cross-grained face (cross-sectional area) of all boards end with the edges of an outer pile strip.
4. Put the second layer of pile strips on the first layer of boards according to step 2. above.	Put the pile strips exactly vertically above the pile strips beneath (check with water level).
5. Put on the second layer of boards according to step 3. above.	Take into account the comments on step 3. above. Put the frontal longitudinal narrow face of the first board and one cross-grained face each vertically above the narrow faces of the boards-beneath (check with water level).
6. Repeat the steps 4. and 5. above until the intended pile height is reached.	Use safe ladder or scaffold when working in bigger height. Secure covering plates by fixing against weather influences.
7. Cover the top of the box-type pile with covering plates.	
8. Identify the pile by fixing an identification plate.	

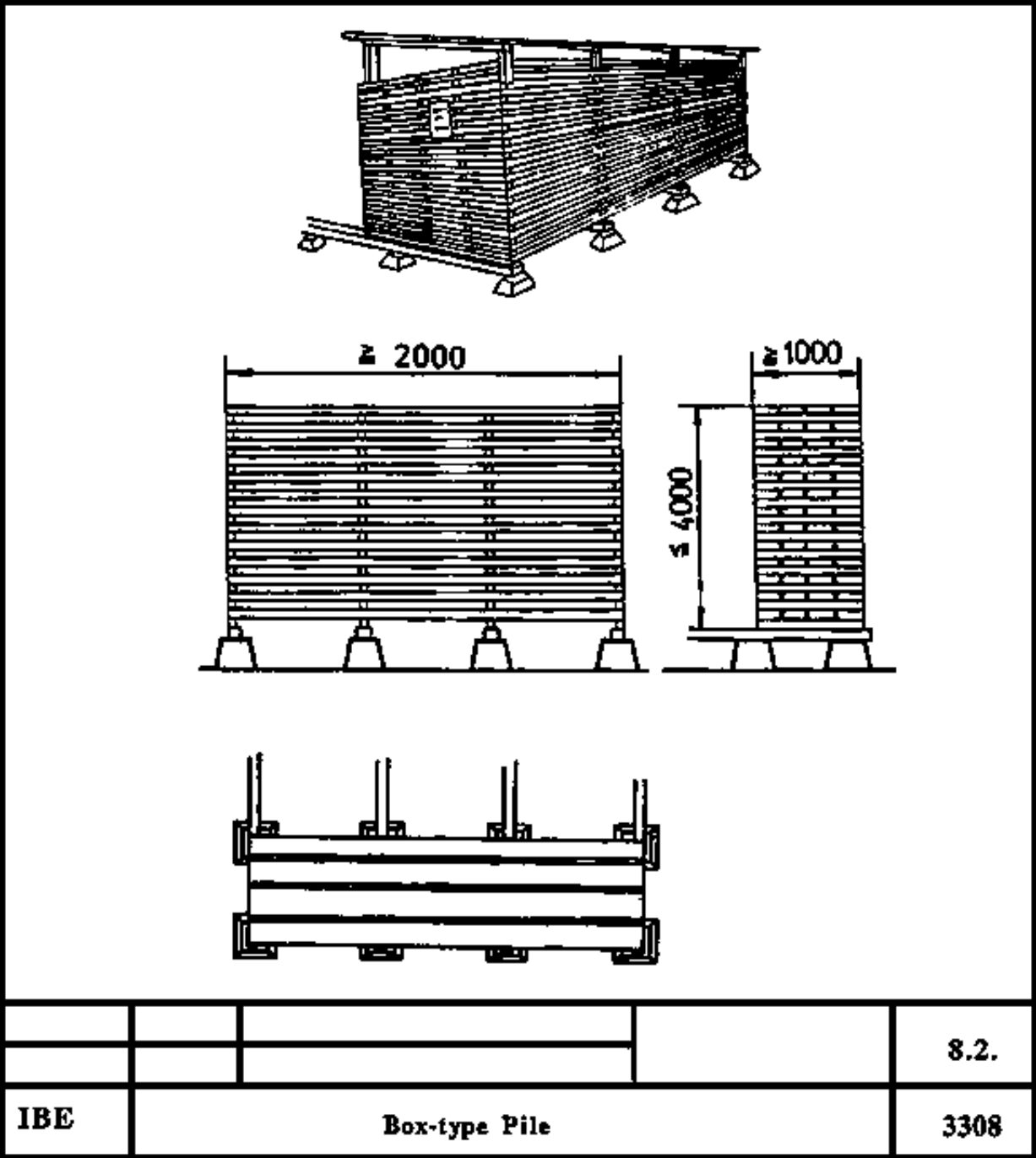

Box-Type Pile



[Home](#) > [ar](#).[cn](#).[de](#).[en](#).[es](#).[fr](#).[id](#).[it](#).[ph](#).[po](#).[ru](#).[sw](#)



 **Maintenance and Storage of Wood - Course: Manual woodworking techniques. Instruction examples for practical vocational training (Institut für Berufliche Entwicklung, 15 p.)**

 ***(introduction...)***

 **Preliminary Remarks**

 **Instruction Example 8.1.: Sawn Timber Storage Yard**

 **Instruction Example 8.2.: Box-type Pile**

 **➔ Instruction Example 8.3.: Double-block Pile**

Instruction Example 8.3.: Double-block Pile

This example serves to practise the construction of a double-block pile. Block-type piles are applied for high-quality timber only.

Material

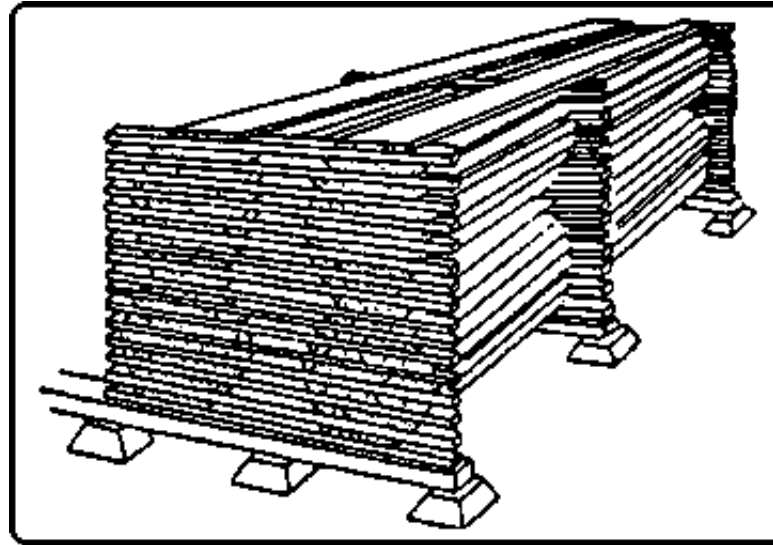

Figure

Unedged-sawn boards completely belonging together, originating from at least two tree trunks or partial lengths from one tree trunk

Dimensions:

Width: as available

Length: at least 2000 mm

Thickness: at least 25 mm

Tools

Metal hammer 250 g to 500 g

Measuring and testing means

Measuring tape or folding rule, long straightedge, stretching line, water level

Auxiliary accessories

Pile strips

Dimensions:

Width: 25 mm to 50 mm

Length: double the bigger board width (trunk diameter) + 200 mm

Thickness: at least 25 mm

Ladders (scaffold), covering plates, identification plate, nails

Necessary previous knowledge

Types of wood, properties of wood, measuring, testing, preparation of a sawn timber storage yard

Sequence of operations	Comments
1. Check the prepared timber yard and pile base for meeting of requirements.	Check the position of the pile stones for joint horizontal and aligned height as well as for straightness in length and width by means of long straightedge or stretching line and water level. Check the position of the squared timbers.
2. Arrange the boards to origin with respect to tree trunk and to order of sequence.	Measure and compare the width of the boards. Visually check and compare the course of the longitudinal edges of the boards and of the annual rings (at the cross-sectional areas).
3. Put pile strips longitudinally on	

the squared timbers of the pile	
base 4. Put two outer boards from different trunks (blocks) side by side and transversely on the pile strips.	The faces of the boards nearer to the heart to show upwards. Ensure a sufficient centre distance of the boards to each other and to the outside in accordance with the biggest board width of the trunks (blocks).
5.. Put the second layer of pile strips on the first layer of boards as per step 3. above.	Put the pile strips exactly vertically above the pile strips beneath (check with water level).
6. Put on the next two boards according to step 4. above.	Take into account the comments on step 4. above.
7. Repeat steps 5. and 6. above until the last two outer boards of the different blocks are stored.	
8. Continue storing boards from other trunks on the lower blocks according to steps 3. to 7. above until the intended pile height is reached.	
9. Cover the top of the double-block pile with covering plates.	Secure the covering plates by fixing them against weather influences.
10. Identify the pile by fixing an identification plate.	

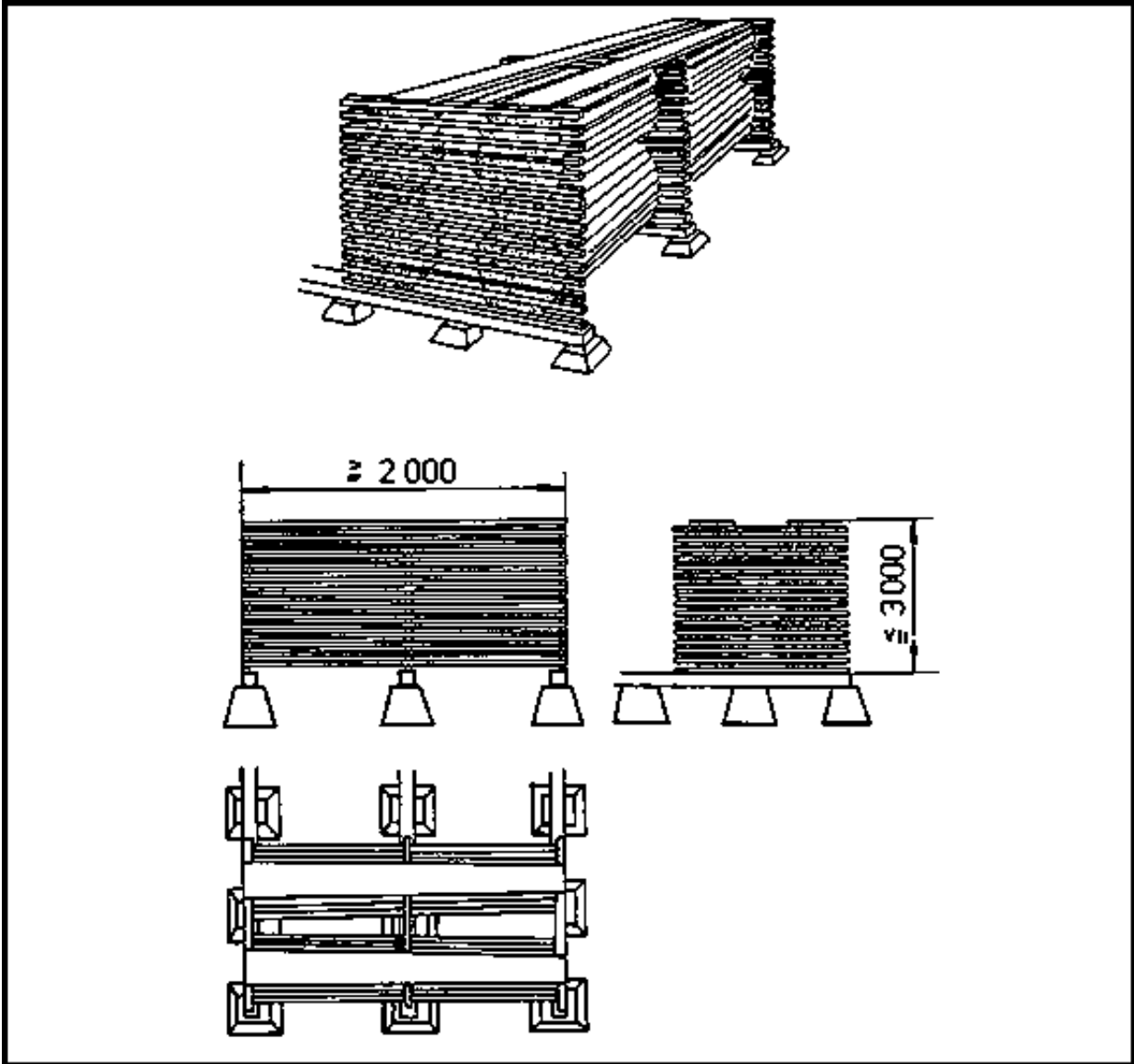

			8.3.
IBE	Double-block Pile		3308

Double-block Pile

