

**Nailing and Screwing – Course: Making of wood joints. Trainees'
handbook of lessons**

Table of Contents

<u>Nailing and Screwing – Course: Making of wood joints. Trainees' handbook of lessons</u>	1
<u>1. Purpose and Application of Nailing and Screwing</u>	1
<u>2. Tools and Fasteners/Joining Elements for Nailing and Screwing</u>	1
<u>3. Nailed and Screwed Joints</u>	7
<u>4. Nailing and Screwing Techniques</u>	9

Nailing and Screwing – Course: Making of wood joints. Trainees' handbook of lessons

**Institut für berufliche Entwicklung e.V.
Berlin**

Original title:
Arbeitsmaterial für den Lernenden
"Nageln und Schrauben"

Author: Harald Stelzer

First edition © IBE

Institut für berufliche Entwicklung e.V.
Parkstraße 23
13187 Berlin

Order No.: 93–35–3501/2

1. Purpose and Application of Nailing and Screwing

Nails and screws are slim metallic fasteners (joining elements) which are driven in and/or screwed in, in order to join two or more relatively thin workpieces or prefabricated parts.

Nailed and screwed joints can be quickly made with simple means and without major constructive expenditure, under erection conditions on the site as well.

Screws are primarily used as joining elements between metal and wood, e.g. the fastening of any kind of mountings on wooden piece parts and furniture. They can be easily loosened – thus making an exchange of the structural members possible. Nails are often used as fasteners/joining elements for several workpieces or prefabricated parts wherever a quick joining of piece parts is possible.

By driving in the nail with a hammer, compressions may occur on the material surface which is not always desired.

Nails and screws can fulfill different tasks:

- as a self-supporting (holding!) joint,
- as a securing (supporting) joint together with other joints and fasteners, e.g. glue.

Nails and screws join the workpieces in one point only. To make an areal joint, it is necessary to drive in and/or screw in several nails or screws at a distance to each other as large as possible.

2. Tools and Fasteners/Joining Elements for Nailing and Screwing

The tool used for driving in the nails, is the joiner's hammer. The hammer consists of a steel hammer head and a handle made of wood. Corresponding to the required effect of impact, they are produced in different weights. In the joiner's shop, hammers with 150 g, 300 g and 600 g weight are generally used. Small nails are driven in with a light hammer, medium-size nails with a medium-weight hammer and large nails with a heavy hammer.

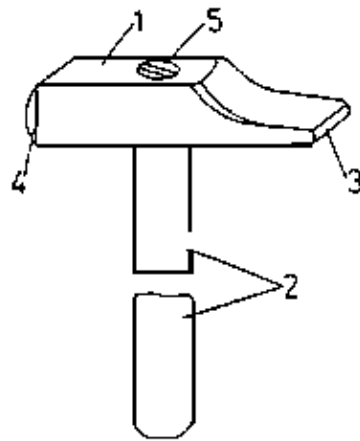

Figure 1 Joiner's hammer

1 hammer head, 2 handle, 3 paw, 4 face, 5 eye

Why are hammers of different weights required?

The hammer handle must be tightly fitted into the eye of the hammer head and flush on top. It must be diagonally wedged!

For sinking the nail heads, a nail punch is used. Punches are made of steel. They have a cylindrical form, run conically towards below and end with a plane, round surface of 2 to 5 mm dia. With this surface, they are applied to the nail head and held with the left hand in the direction of the nail. By slight blows with the hammer on the head of the nail punch, the nail head is driven into the wood.



Figure 2 Nail punch

When sinking, there is a risk of bouncing, therefore the nail punch has to be held fast and safely, it must not slip off the nail head!

What are nail punches used for?

The tool used for driving in or loosen screws, is the screw driver. It consists of a steel blade, having the form of a wedge at the end and being slightly hollow–chamfered, which is joined with a handle. The screw drivers are made in different sizes. The size to be used depends on the screws to be driven in. The end of the screw driver must correspond to the dimension of the screw slot so that it is possible to drive in or out the screw without damaging the slot of the countersunk–head screw or the wood edge.

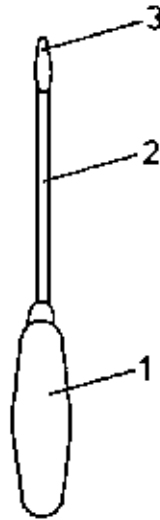

Figure 3 Screw driver

1 handle, 2 blade, 3 driving edge

If too much force is applied, there is a risk of slipping off and hence a risk of injury!

Depending on the application, nails and screws are manufactured in different kinds, forms and sizes. The following kinds are distinguished:

Nails

Unhardened steel nails

They are called wire or French nails. These nails are primarily used in joineries.

Hardened steel nails

Steel nails, due to their high strength, penetrate hard materials as well, e.g. brickwork, without being bent.

Hot-dip galvanized nails

Galvanized nails are wire nails with a zinc coating. By this, a good protection of the surface against corrosion is achieved. They are used for structural parts which are exposed to the influence of the weather.

Screws

Screws are made of steel or anti-corrosive alloys. Wood screws are also made of brass or aluminium. These screws are mainly required for the fastening of mountings of the corresponding material.

Why are different kinds of nails and screws necessary?

As to form, one differentiates between the following kinds:

Nails

Flat head nails

Flat head nails are used when thin sheet materials, e.g. plywood, hard boards, are fastened to solid wood (rear walls for furniture). Flat head nails are not suited for being sunk.

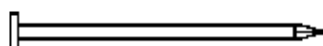

Figure 4 Flat head nail

Counter sunk–head nails

Countersunk–head nails are used for joining wood pieces. They have the form which is in common use in a joinery.

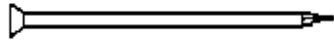

Figure 5 Countersunk–head nail

Upset–head nails

Upset–head nails are driven in when the nail head shall not be visible. When fastening thin sheet materials, there is a risk that the head penetrates the sheet material and does not hold it fast.

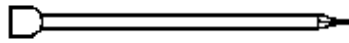

Figure 6 Upset–head nail

Apart from these nail forms, a variety of special nail forms for the most diverse applications are used. Among these are nails without heads, as well as ornamental nails and pins.

Screws

Counter sunk–head wood screw

Countersunk–head wood screws can be driven into the wood so that they are flush with the surface. They are the screw form which is generally used in a joinery.

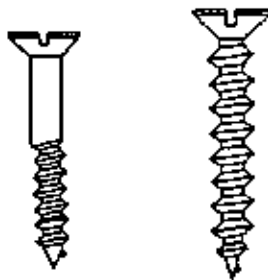

Figure 7 Countersunk–head wood screw

Oval head countersunk wood screw

Oval head countersunk wood screws are used for the fastening of mountings.

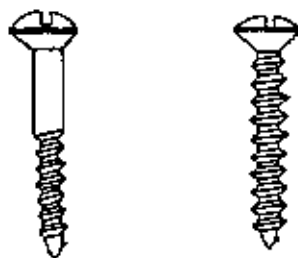

Figure 8 Oval head countersunk wood screw

Round head wood screw

Round head wood screws are not suited for being sunk. They are used for the fastening of mountings and as ornamental screws.

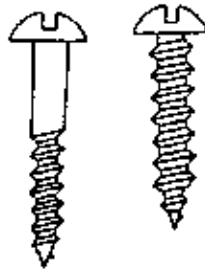

Figure 9 Round head wood screw

Hexagon head wood screw

Hexagon head wood screws are used in the structural timber construction, e.g. supporting structures, roof coverings. They are screwed in and/or screwed out with the screw wrench.

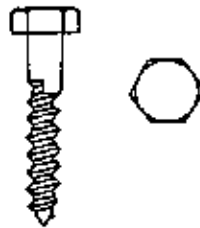

Figure 10 Hexagon head wood screw

Cup square bolt

Cup square bolts are used for fastening the screw-on braces to the door leaf. The square situated under the head fits in a square hole correspondingly punched in the mounting or wood. This screw is fastened with a washer and a hexagonal nut. The cup square bolt cannot be loosened on the mounting side. For the fastening of chipboards, countersunk-head screws or round head screws with the thread extending over the entire length of the cylindrical shank are used.

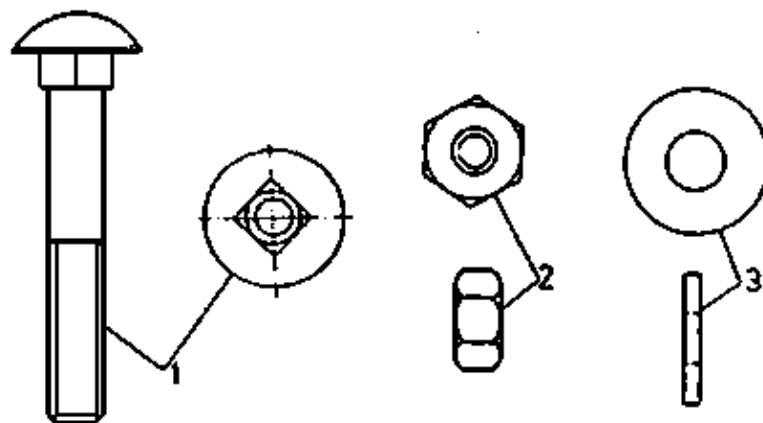

Figure 11 Cup square bolt

1 head with square, 2 nut, 3 washer

Table 1: Nail sizes

Flat head nails		Countersunk-head nails		Upset-head nails	
Length	Diameter	Length	Diameter	Length	Diameter
mm	mm	mm	mm	mm	mm

6	0.6	20	1.4	8	0.8
8	0.6	25	1.6	10	0.8
10	0.8	30	1.8	12	1
12	1	35	1.8	14	1
14	1	40	2	16	1
16	1	45	2.2	18	1.2
20	1.2	50	2.2	20	1.4
25	1.4	55	2.5	25	1.4
30	1.6	60	2.5	30	1.6
		65	2.8	35	2
		70	3.1	40	2
		80	3.1	45	2
		90	3.4	50	2
		100	3.8	60	2.5
		110	4.2	70	3.1
		120	4.2	80	3.1
		130	4.6	100	3.8
		140	4.6		
		160	5.5		
		180	6		
		200	6		

Table 2: Screw sizes

Countersunk-head wood screw							
Oval head countersunk screw			Hexagon head wood screw			Cup square bolt	
Round head wood screw							
Length	Diameter		Length	Diameter		Length	Diameter
	Shank	Thread core		Shank	Head		Thread
mm	mm	mm	mm	mm	mm	mm	mm
7	1.5 – 3	1 – 2.1	30	6 – 10	10 – 17	25	M5
10	1.5 – 3	1 – 2.1	35	6 – 10	10 – 17	30	M5 – M6
15	1.5 – 4	1 – 2.8	40	6 – 10	10 – 17	35	M5 – M8
20	2 – 6	1.4 – 4.2	45	6 – 12	10 – 19	40	M5 – M10
25	2.5 – 6	1.7 – 4.2	50	6 – 12	10 – 19	45	M5 – M12

30	3 – 6	2.1 – 4.2	60	6 – 10	10 – 24	50	M5 – M12
35	3 – 6	2.1 – 4.2	70	6 – 16	14 – 24	55	M5 – M16
40	4 – 8	2.8 – 5.6	80	8 – 20	14 – 30	60	M5 – M16
45	4 – 6	2.8 – 4.2	90	8 – 20	14 – 30	65	M6 – M16
50	4 – 8	2.8 – 5.6	100	8 – 20	14 – 30	70	M5 – M16
60	5 – 8	3.5 – 5.6	110	8 – 12	14 – 19	75	M6 – M16
70	6 – 8	4.2 – 5.6	120	8 – 20	14 – 30	80	M6 – M16
80	6 – 8	4.2 – 5.6	130	8 – 12	14 – 19	90	M6 – M16
			140	10 – 20	17 – 30	100	M8 – M16
			150	12 – 20	19 – 30		
			160	16 – 20	24 – 30		
			180	16 – 20	24 – 30		
			200	16 – 20	24 – 30		

Nails and screws are denominated as to

- form,
- required material, e.g. bare, galvanized, brass, etc.,
- required shank diameter, and
- length.

Example:

Countersunk-head screw, brass, 3 x 30
(shank diameter = 3 mm; length = 30 mm)

3. Nailed and Screwed Joints

Nailed joints

When in the manufacture of supports and girders more than two boards shall be joined by means of nails, then these joints have to be made as two-shear or multi-shear nailed joints. These joints have to be statically calculated. Correspondingly, the kind, size and number of nails to be used are specified. Depending on the existing joint surface and in consideration of the minimum distances, nailing patterns (nailing points) are fixed. Nailing is done by means of patterns.

Single-shear nailed joints are produced when two parts are nailed together. In doing so, the nails are normally tensile-stressed in their longitudinal axis. This ability of the nail to absorb tensile forces is called "extraction resistance". Among other factors, the extraction resistance is determined by the strength of the wood, the nail length and the shank dia. of the nail. When driving in the nail, the wedge-type point punches through and destroys a part of the fibres of the wood. The other fibres are pushed aside and compressed and clamp the nail shank. The strength of a nailed joint increases proportionally to the number of nails if the

minimum distances between the nails and the distances to the edge are observed.

The minimum distances between the nails are calculated proceeding from the diameter of the nail shank (d). When nailing in a row with the grain and side by side, the distances are not less than 10 d. The distance from the edge in grain direction must be at least 5 d, the distance from the board ends at least 10 d. The following rule applies: "Nail as many nails as necessary, not as many as possible!"

Frame corners are nailed with 2 to 4 nails which shall have a distance from each other as large as possible.

Nailings in a row (rear walls of furniture, glass strips) are made in dependence on the nail size at a distance of 100 to 200 mm.

Why are minimum distances between the nails and distances from the edge to be adhered to?

As far as no constructional requirements are in contrast with it, the following basic rules are to be followed:

- Nailing is performed from the soft into the hard wood.
- Nailing is performed from the thin into the thick wood.
- When nailing in hard wood, pre-drilling has to be carried out. The diameter of the drill is 0.8 d of the nail.
- When nailing in cross-cut wood, the nails have to be driven in at an angle so that they penetrate several annual rings, if possible. Nails which are vertically driven into cross-cut wood have hardly any extraction resistance!
- When nailing through round wood, nailing has to be done along the tangent line!
- When nailing at the ends of a board, the nail points are upset so as to reduce their effect of splitting.

Screwed joints

Multi-shear screwed joints (pressure- or tensile-stressed) are required in the wood construction work (supporting frameworks such as roof frameworks, bridges, scaffoldings). They are executed with through screw bolts. The screws are fastened with washers and nuts.

Wood screws are used as joining elements and fasteners for wood parts or for the fitting of mountings. The screws are tensile-stressed as to their longitudinal axis. In case of a proper mounting, wood screws have a very large extraction resistance. They must not be driven in with a hammer!

Screw holes are to be pre-drilled!

About 60 % of the length of the wood screw is provided with a thread which draws in or loosens the screw at a rotary motion and light pressure.

Holes

For small screws can be pre-cut with a steel square having the respective size; for larger screws, the holes must be pre-drilled. Doing so, the bore-hole with the diameter of the screw shank or slightly less has to be executed some 40 % of the screw length deep. As for large screws, it can be necessary to pre-drill additionally some 40 % of the screw length with the diameter of the thread core. Cup square bolts are pre-drilled with their shank diameter + 0.4 mm.

Pre-drilling of the screw holes saves force to be applied when screwing in the screws and prevents the screw driver from slipping off if too much pressure is applied!

4. Nailing and Screwing Techniques

Nailing techniques

Nailing is effected on a firm, not springy support. The nail, when being driven in, is held and guided with the left hand at the shank until it sticks sufficiently deep and tight in the wood. The hammer is taken with the right hand at the end of the handle; hammering is done from the wrist. The hammer must be guided slackily and without clenching. When driving in the nail, the direction of the blows must be the longitudinal axis of the nail. Nailing is done with the hammer face.

Nailing of a lath grid

This simple nailing technique is applied when wood joints of laths and crosspieces (joists) shall be made by means of nails. With determining the nailing points, the required distances to the edge have to be adhered to.

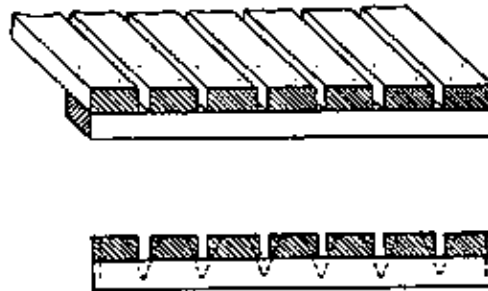

Figure 12 Nailing of a lath grid

The nails to be driven into the first and the last lath must be upset so as to avoid a splitting of the crosspieces. For upsetting, the nail is put with its head on a firm support and held fast. By slight blows with the hammer onto the nail point, it is upset through which the splitting effect of the nail is reduced.

Each lath is nailed to each crosspiece with two nails. To increase the durability of each joint, the rear nail is nailed with an inclination towards the back and the other nail with an inclination towards the front. The inclined position of the nails shall be about 15° deviating from the vertical. The nail length is at least double as long as the thinner board but shorter than both parts.

Nailing of a halved frame corner joint

This nailing technique is used for subordinated structural parts (makeshift nailing) only.

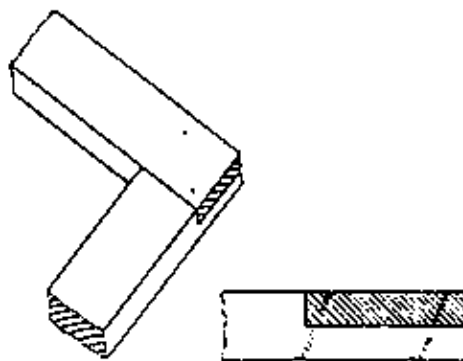

Figure 13 Nailing of a halved frame corner joint with presentation of the clinched nail

This nailing technique with overlong nails implies a risk of injury due to bursted out wood fibres and projecting nail points!

The nails are driven in with the grain as to the lower surface with an inclination of 15° deviating from the vertical. The point of the nail is deflected through slight blows of the hammer when it impacts on the steel plate and then penetrates the wood again. The workpiece has to be firmly pressed onto the steel plate (screw clamp). The nail length is about $10 \text{ mm} +$ the overall wood thickness.

Nailing of a tool kit

In addition to the simple nailing, the nailing with overlong nails, as well as folding back and hammering back of the overlength is important.

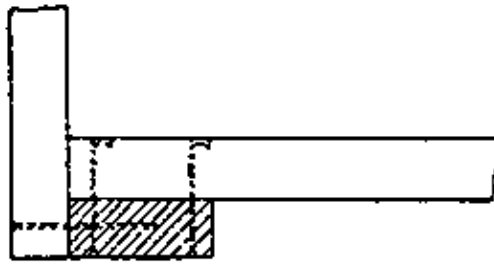

Figure 14 Nailing of a tool kit

The nails are driven into the laths and boards vertically and flush with the surface. Base blocks of wood are to be used so that the nails do not penetrate the joiner's bench.

The workpiece must not be springy; otherwise there is a risk of slipping off when hammering and so there is a risk of injury!

Nailing is done in the form of a triangle. When folding back the nails, the steel bar must be firmly pressed against the nail shank. It has to be seen to it that a firm support is used so that the nails cannot be hammered out and that the nail head remains flush with the wood surface. Folding back of the nails is accomplished in the grain direction of the wood. Hammering is done with the hammer face, on principle.

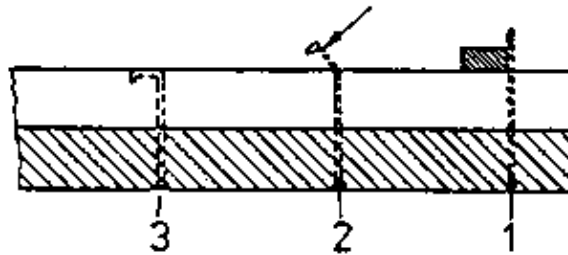

Figure 15 Folding back of the overlong nail

1 nail driven in, 2 nail folded back at the steel bar, 3 nail point hammered back into the wood

The distances of the nails to the edge are absolutely to be observed!

The nail length is at least 15 mm + the overall wood thickness.

Nailing of a wall panel

This nailing technique can be applied if large areas of boards with shaped grooves and tongues shall be produced on a sub-structure of wood. The advantage of this is that the nails are invisible after completion.

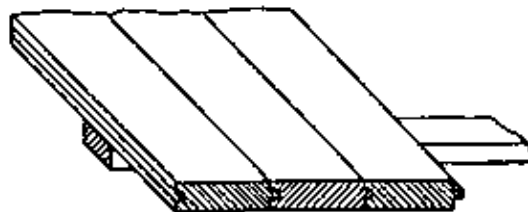

Figure 16 Nailing of a wall panel

The first board on the left-hand side is begun with. After an exact aligning, the board is nailed from the front onto the sub-structure close to the left-hand narrow surface (groove side). On the right-hand side, this board and all following ones are not nailed onto the sub-structure from the front but at the narrow surface through the shoulder line of the tongue.

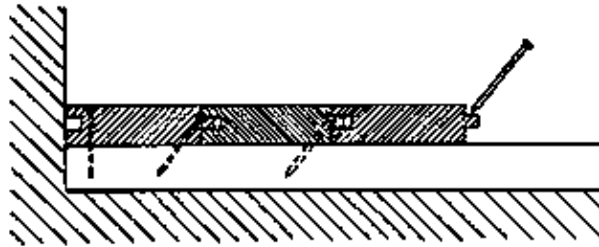

Figure 17 Covered nailing

The nails are driven in at an angle of 120° to 135° . To avoid damages of the wood edges and the tongue, the last blows are made by using the nail punch. The nail head is sunk. The nail length has to be chosen in dependence on the construction.

Screwing technique

When several screws shall be driven into a workpiece, then the individual parts have to be secured against shirting.

Pre-drilling and/or pre-cutting is necessary in any case!

To maintain the screwing-in and/or drawing-out resistance, the screw holes must not be pre-drilled too large and not too deep. The end of the insert of the screw driver shall have the width of the screw head diameter. It must fit exactly into the screw slot. When driving in the screw, the screw head and the end of the insert of the screw driver have to be guided with the left hand.

Do never drive in screws with a hammer!

Bore holes for cup square bolts are to be pre-drilled through all parts to be joined with $d + 0.4$ mm. Cup square bolts are driven in by slight blows with a hammer and fastened with washers and nuts. The length depends on the thickness of all parts to be joined, adding about + 10 mm.

Screwing of a carrying handle to a tool kit by means of counter sunk-head screws

This screwing technique can be used for fastening a board onto another. The screwing points shall give a regular picture but shall not lie in the same annual ring.

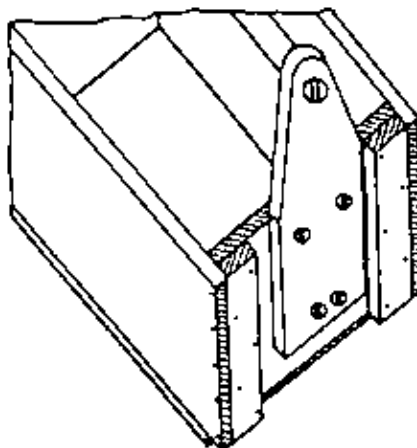

Figure 18 Screwing of a carrying handle to a tool kit

After scribing and marking the screwing points at the handle holder, the holes are pre-drilled 12 mm deep with the shank diameter of the countersunk-head screws (3 mm). The bore holes at the front are reamed with the rose bit. After fastening the handle holders to the tool kit by means of screw clamps, the screw holes are concentrically pre-drilled deeper by another 12 mm with the drill dia. 2 mm.

The countersunk-head screws are put into the bore-holes by applying pressure with the thumb (do not use a hammer!) and screwed clock-wise into the wood with a suitable screw driver by applying light pressure. Doing so, the end of the blade of the screw driver and the head of the countersunk-head screw are to be guided

with the left hand. Thereby it is avoided that the screw driver slips off the slot of the screw head.

By the screw driver slipping off, the wood surface may be damaged and accidents (injuries of the left hand) may occur. Screw driver handles must be clean, tightly fitting and non-slipping!

Why must wood screws not be driven in with a hammer?

Screwing on of a screw-on brace

By applying this screwing technique, metal mountings can be fastened to structural parts of wood.

The selection of the respective screw shank diameter depends on the prepared holes at the metal mountings. The shank diameter of the screw shall be about 0.4 mm smaller than the hole diameter in the mounting.

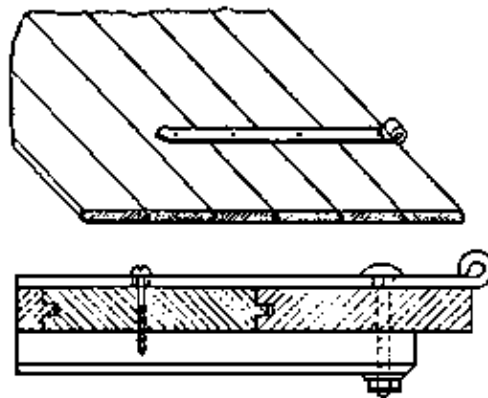

Figure 19 Screwing on of a screw-on brace

The screw length is chosen in dependence on the thickness of all parts to be joined. The wood screws are shorter than the parts to be joined. The cup square bolts are abt. 10 mm longer than the thickness of all parts to be joined so that the washer and the lock nut can be screwed on.

After scribing, the bore holes for the wood screws are vertically pre-drilled about $0.4 \times$ screw length deep with the shank diameter of the chosen wood screws and after that, if hard wood or large screws are used, the same depth is drilled once again with the diameter of the thread core. The hole for the cup square bolt is drilled with the diameter $0.4 + d$ of the screw through all wood parts to be joined. Here, splitting of the wood fibres has to be avoided when the drill comes out of the wood.

After scribing the hole, take off the mounting and do not guide the drill through the hole in the mounting!

The cup square bolt is driven through the hole in the mounting and the bore hole by slight blows with the hammer and fastened from below with a washer and a nut. The square neck must tightly stick in the punched hole of the mounting.

The wood screws are screwed in with the appropriate screw driver. In doing so, the screw head and the end of the screw driver are guided with the left hand and secured against slipping.