

[Home](#) > [ar.cn.de.en.es.fr.id.it.ph.po.ru.sw](#)

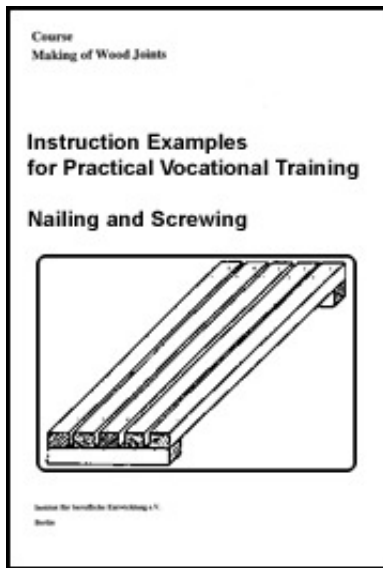







- ➔ **Nailing and Screwing - Course: Making of wood joints. Instruction examples for practical vocational training (Institut für Berufliche Entwicklung, 29 p.)**
- 📄 **(introduction...)**
 - 📄 **Preliminary Remarks**
 - 📄 **Instruction Example 01.1. Nailing of a Lath Grid**
 - 📄 **Instruction Example 01.2. Nailing of a Halved Frame Corner Joint**
 - 📄 **Instruction Example 01.3. Nailing of a Tool Kit**
 - 📄 **Instruction Example 01.4. Nailing of a Wall Panel**
 - 📄 **Instruction Example 01.5. Screwing of a Carrying Handle on a Tool Kit**
 - 📄 **Instruction Example 01.6. Screwing on of a Screw-on Brace**

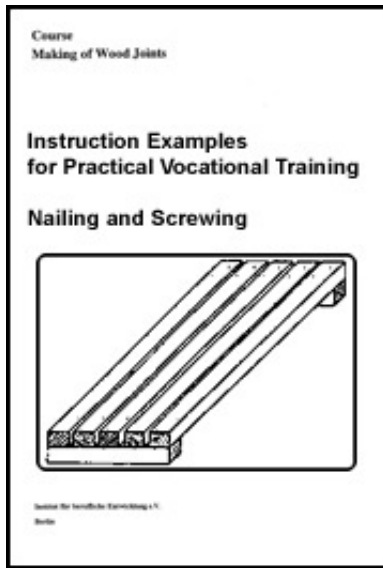

[Home](#) > [ar.cn.de.en.es.fr.id.it.ph.po.ru.sw](#)

- 📖 **Nailing and Screwing - Course: Making of wood joints. Instruction examples for practical vocational training (Institut für Berufliche Entwicklung, 29 p.)**
- ➔ 📄 **(introduction...)**
 - 📄 **Preliminary Remarks**



-  **Instruction Example 01.1. Nailing of a Lath Grid**
-  **Instruction Example 01.2. Nailing of a Halved Frame Corner Joint**
-  **Instruction Example 01.3. Nailing of a Tool Kit**
-  **Instruction Example 01.4. Nailing of a Wall Panel**
-  **Instruction Example 01.5. Screwing of a Carrying Handle on a Tool Kit**
-  **Instruction Example 01.6. Screwing on of a Screw-on Brace**

**Institut für berufliche Entwicklung e.V.
Berlin**

Original title:

**Lehrbeispiele für die berufspraktische Ausbildung
"Nageln und Schrauben"**

Author: Harald Stelzer

First edition © IBE

**Institut für berufliche Entwicklung e.V.
Parkstraße 23
13187 Berlin**

Order No.: 93-33-3501/2

[Home](#) > [ar](#).[cn](#).[de](#).[en](#).[es](#).[fr](#).[id](#).[it](#).[ph](#).[po](#).[ru](#).[sw](#)

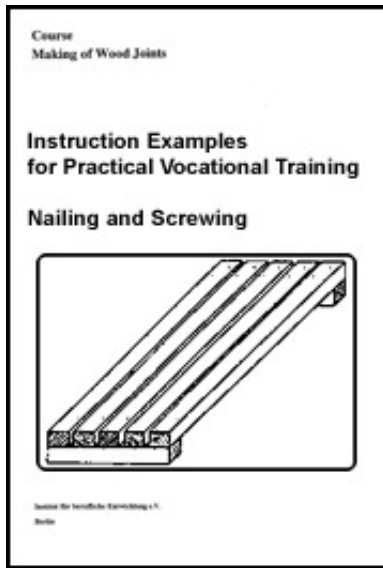

 **Nailing and Screwing - Course: Making of wood joints. Instruction examples for practical vocational training (Institut für Berufliche Entwicklung, 29 p.)**

 **(introduction...)**

  **Preliminary Remarks**

 **Instruction Example 01.1. Nailing of a Lath Grid**

 **Instruction Example 01.2. Nailing of a Halved Frame Corner Joint**

 **Instruction Example 01.3. Nailing of a Tool Kit**

 **Instruction Example 01.4. Nailing of a Wall Panel**

 **Instruction Example 01.5. Screwing of a Carrying Handle on a Tool Kit**

 **Instruction Example 01.6. Screwing on of a Screw-on Brace**

Preliminary Remarks

The present documentation contains six selected instruction examples which serve to apply and consolidate the knowledge and skills of nailing and screwing techniques.

The basic idea of this technique is the making of wood joints, as well as the fastening of mountings on wood by means of nails or screws.

Each of the six selected instruction examples offers different possibilities to make wood joints or fasten mountings by means of nails or screws for holding or securing the parts to be joined.

The following criteria are to be considered:

- kind and extent of load the joint is exposed to**
- durability**
- optical-esthetical appearance**
- risk of injury.**

The kinds of joints offered in the instruction examples can be practised on other workpieces as well depending on the requirements of the trainee's working range and/or factory.

This could be for example:

- fastening of floor boarding, rear walls of furniture**
- assembly of picket fences, batten doors and plank doors, transport boxes**
- mounting on furniture and structural wood members, makeshift furniture.**

To facilitate the preparation and implementation of the works, the materials, tools, measuring, testing and auxiliary means required for each instruction example are stated.

The work routine mentioned for the individual instruction examples contains the sequence of operations which are necessary for making the nail and/or screw joint.

A work drawing is attached to each example which shows the type and arrangement of the nails or screws as well as the shapes and/or dimensions of the workpiece.



[Home](#) > [ar](#).[cn](#).[de](#).[en](#).[es](#).[fr](#).[id](#).[it](#).[ph](#).[po](#).[ru](#).[sw](#)

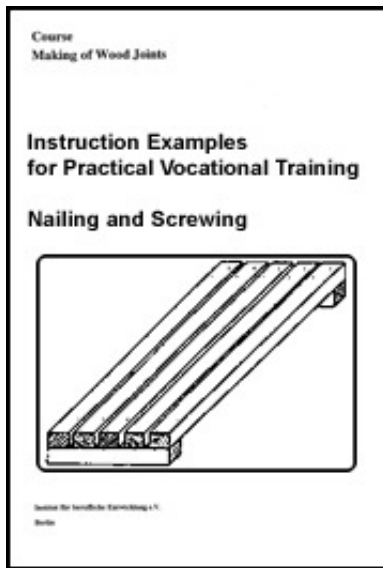



 **Nailing and Screwing - Course: Making of wood joints. Instruction examples for practical vocational training (Institut für Berufliche Entwicklung, 29 p.)**

 **(*introduction...*)**

 **Preliminary Remarks**

  **Instruction Example 01.1. Nailing of a Lath Grid**

 **Instruction Example 01.2. Nailing of a Halved Frame Corner Joint**

 **Instruction Example 01.3. Nailing of a Tool Kit**

 **Instruction Example 01.4. Nailing of a Wall Panel**

 **Instruction Example 01.5. Screwing of a Carrying Handle on a Tool Kit**

 **Instruction Example 01.6. Screwing on of a Screw-on**

Brace

Instruction Example 01.1. Nailing of a Lath Grid

In this instruction example, nailing in long wood is practised.

Material

7 laths

thickness: 25 mm

width: 40 mm

length: 600 mm

2 crosspieces

thickness: 45 mm

width: 50 mm

length: 400 mm

Medium-firm wood

Countersunk-head nails 60 mm long

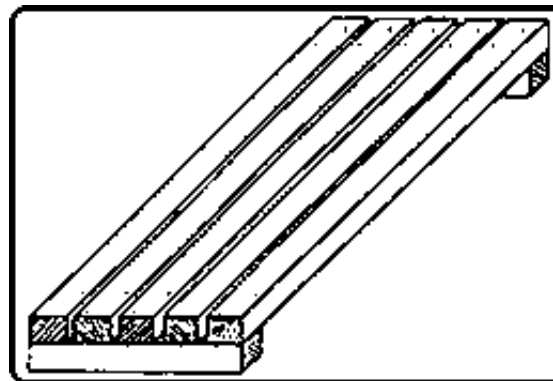

Figure

Tools:

hammer, nail punch, pincers

Measuring and testing means:

back square, folding rule, vernier caliper

Auxiliary means:

spacing strip 20 mm thick, 20 mm wide, 600 mm long; firm, non-springy bench top at working height; pencil

Required previous knowledge

reading of drawings, measuring and scribing

Sequence of operations Comments

1. Prepare the workplace, Check the completeness of tools and materials!
make the working materials available
2. Mark the outer edges of the cross members on the working plane
Putch both crosspieces at a distance of 500 mm (inside) in parallel to each other on the working plane and mark the outer edges on the working plane with a pencil.
3. Put the laths together, determine the nailing
When fixing the nailing points, observe the required distances from the edge so as to avoid splitting of the wood!

points and mark them
with a pencil

4. Nail the rear lath

Put the rear lath flush onto the crosspieces. First, drive in one nail on each side, check the angularity, if necessary, correct it, then drive in the second nail on each side. Prior to this, the nails ate to be upset!

5. Pin the front lath

Put the front lath flush on the cross members and pin it. Do not drive in the nails completely!

6. Nailing of all the other laths

Put the spacing strip against the rear lath, put the next lath flush onto the crosspieces and nail. Proceed in the same way with all the other laths.

7. Nailing of the front lath

Draw out the tack nails at the front lath, place the lath so that it is flush, upset the nails and nail!

8. Driving in of the nail heads

Drive in the nail heads means by of a hammer and a nail punch. It is sunk abt. 3 mm deep.

9. Final check

Visual check: check angularity, check whether the distances between the laths are all the same! The laths and crosspieces must not be splitted visibly, the nails must completely stick in the wood!

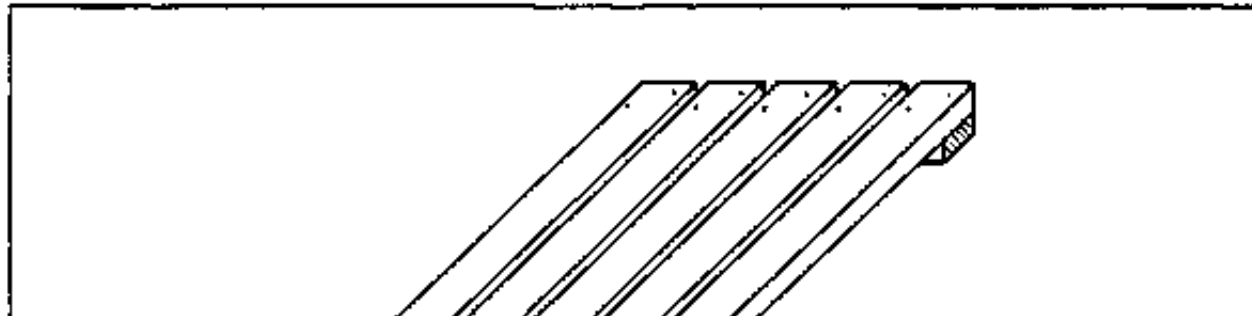

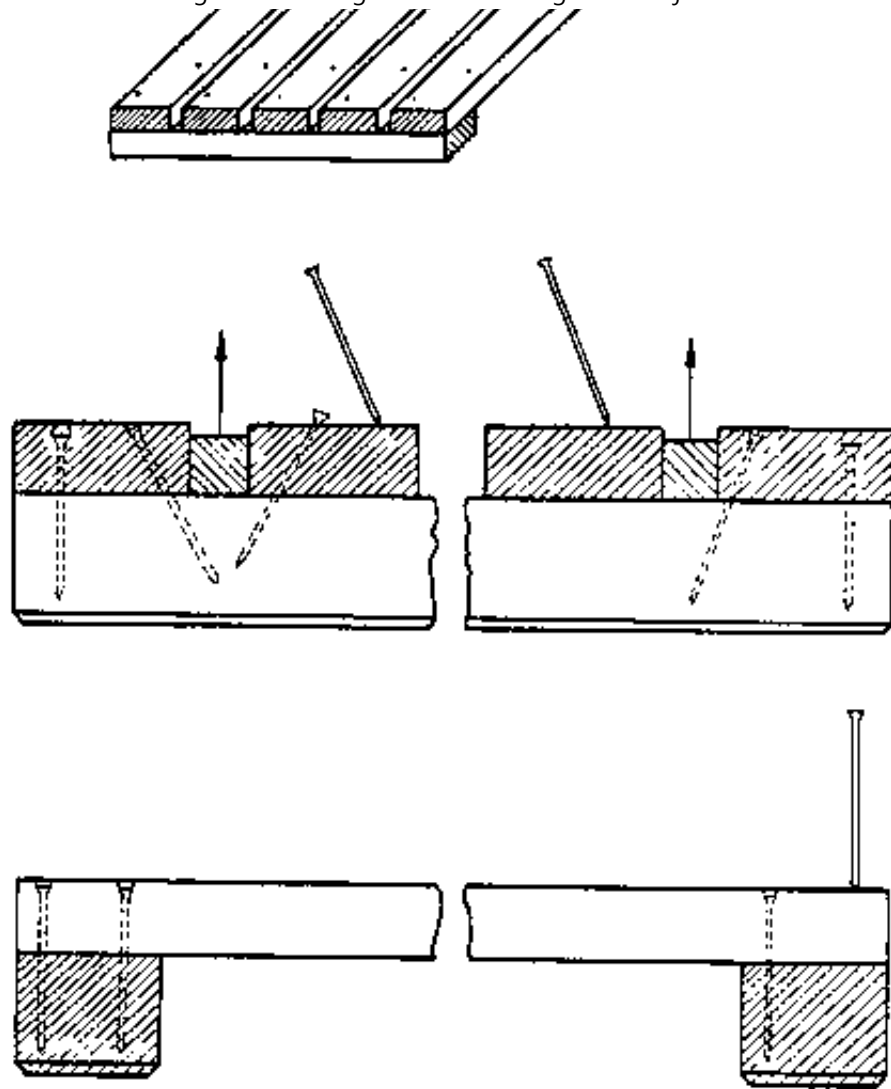









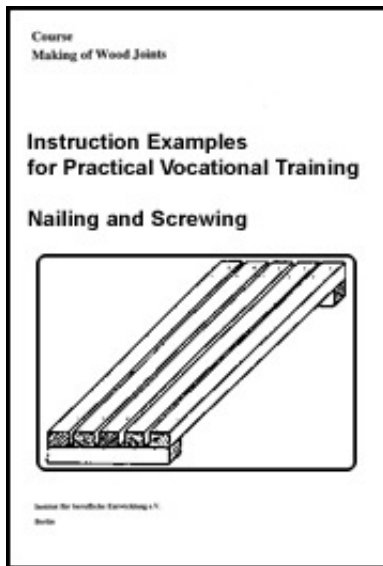

				01.1.
TRF		Nailing of a T-joint		1501

Nailing of a Lath Grid



[Home](#) > [ar](#).[cn](#).[de](#).[en](#).[es](#).[fr](#).[id](#).[it](#).[ph](#).[po](#).[ru](#).[sw](#)



-  **Nailing and Screwing - Course: Making of wood joints. Instruction examples for practical vocational training (Institut für Berufliche Entwicklung, 29 p.)**
-  **(introduction...)**
-  **Preliminary Remarks**
-  **Instruction Example 01.1. Nailing of a Lath Grid**
-  **Instruction Example 01.2. Nailing of a Halved Frame Corner Joint**
-  **Instruction Example 01.3. Nailing of a Tool Kit**
-  **Instruction Example 01.4. Nailing of a Wall Panel**
-  **Instruction Example 01.5. Screwing of a Carrying Handle on a Tool Kit**
-  **Instruction Example 01.6. Screwing on of a Screw-on Brace**

Instruction Example 01.2. Nailing of a Halved Frame Corner Joint

In this instruction example, nailing of a glued frame corner joint with clinched

nails is practised.

Material

halved frame corner joint, glued,

thickness of the legs: 26 mm

width of the legs: 50 mm

countersunk-head nails 30 mm long, unhardened

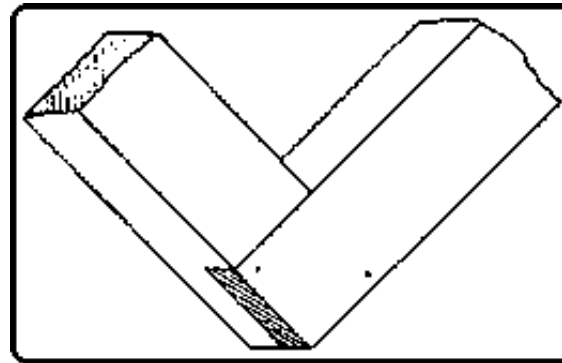

Figure

Tools

hammer, pincers

Measuring and testing means

back square, folding rule, vernier caliper

Auxiliary means

unhardened steel plate, 200 x 200 mm, 10 mm thick, as base plate; firm, non-springy bench top at working height (joiner's bench); pencil

Required previous knowledge

reading of the drawing, measuring and scribing

Sequence of operations

Comments

- | | |
|---|---|
| 1. Prepare the workplace, make tools and working materials available. | Check the completeness of tools and materials! |
| 2. Determine the nailing points and mark them with a pencil. | Observe the required distance from the edge, adhere to the nail picture according to the work drawing! |
| 3. Fasten the frame in preparation of nailing | Place the steel plate (base plate) at the endscrew onto the joiner's bench, put on the frame corner and clamp it between the cramp irons, fasten the frame corner with a screw clamp to the bench plate! |
| 4. Drive in the nails at the nailing points | Observe the inclined position of the nails, the nail points must show in the direction of the grain of the lower surface. Drive in the nails with precise blows until the nail heads are flush with the wood surface. |
| 5. Unclamp the frame | Loosen the endscrew, undo the screw clamp. |

6. Final check

Check:

- for proper inclined position of the nails
- whether the wood surface is not deformed by the blows with the hammer
- whether the nail heads are flush with the wood surface
- whether the nail points are properly clinched and entirely driven into the wood
- for splitting of the wood and torn out wood fibres

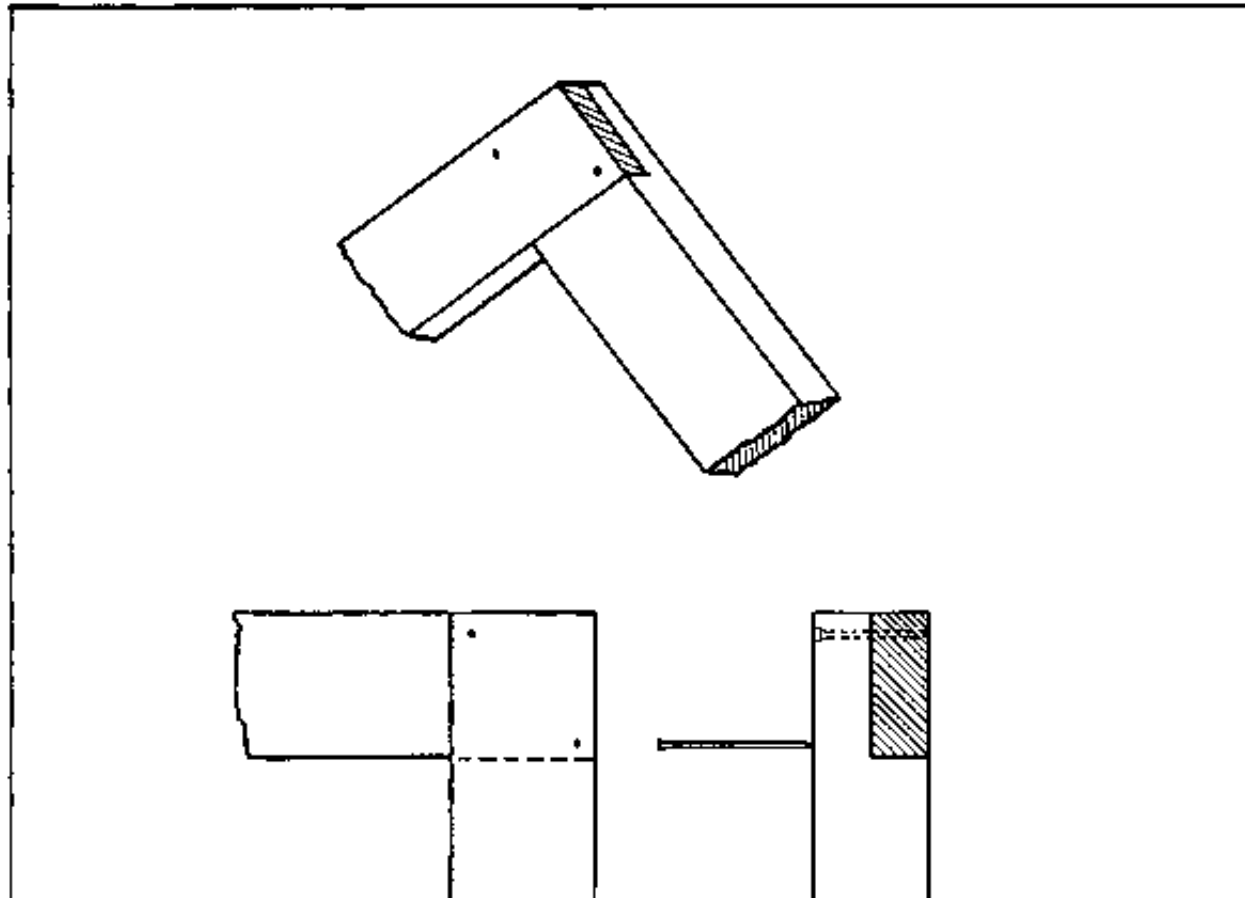

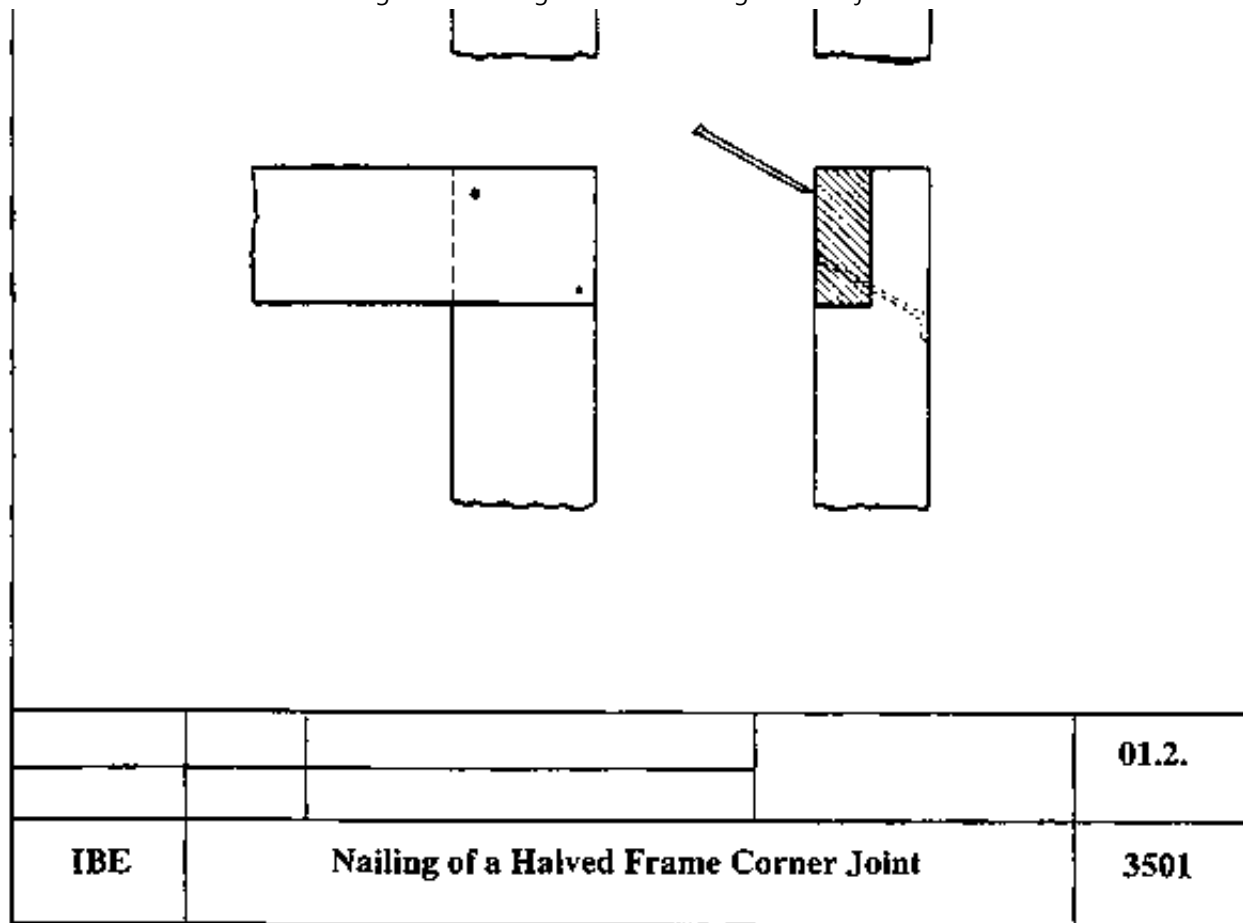

Nailing of a Halved Frame Corner Joint



[Home](#) > [ar](#) [cn](#) [de](#) [en](#) [es](#) [fr](#) [id](#) [it](#) [ph](#) [po](#) [ru](#) [sw](#)

 **Nailing and Screwing - Course: Making of wood joints. Instruction examples for practical vocational training (Institut fr Berufliche Entwicklung, 29 p.)**

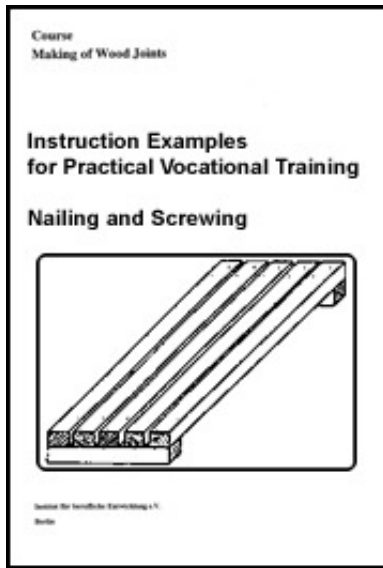

 **(Introduction) Preliminary Remarks**

 **Instruction Example 01.1. Nailing of a Lath Grid**

 **Instruction Example 01.2. Nailing of a Halved Frame Corner Joint**

 **→ Instruction Example 01.3. Nailing of a Tool Kit**

 **Instruction Example 01.4. Nailing of a Wall Panel**

 **Instruction Example 01.5. Screwing of a Carrying Handle on a Tool Kit**

 **Instruction Example 01.6. Screwing on of a Screw-on Brace**

Instruction Example 01.3. Nailing of a Tool Kit

In this instruction example, the simple nailing techniques in long wood and nailing with overlong nails are practised.

Material

2 boards

thickness: 14 mm

width: 200 mm

length: 500 mm

2 boards

thickness: 14 mm

width: 200 mm

length: 250 mm

1 bottom board
thickness: 14 mm
width: 278 mm
length: 468 mm
4 laths
thickness: 16 mm
width: 40 mm
length: 210 mm
countersunk-head nails 45 mm long.

The complete wood is planed out, surface-shaped and cut to size.

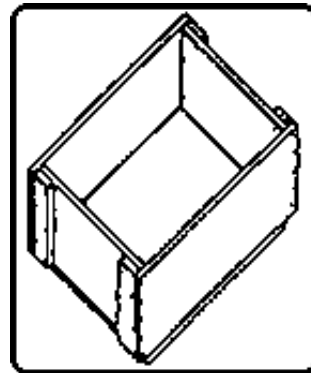

Figure

Tools

hammer, pincers

Measuring and testing means

back square, folding rule, vernier caliper

Auxiliary means

firm, non-springy bench top at working height (joiner's bench), steel bar 20 x 10 mm, 300 mm long, packing blocks of wood 25 mm thick, tacking nails 25 mm long, screw clamp 200 mm

Required previous knowledge

reading of the drawing, measuring and scribing

Sequence of operations Comments

- | | |
|---|--|
| 1. Prepare the workplace, make the working materials available. | Check the completeness of tools and materials! |
| 2. Check the material for accuracy to size and angularity. | All boards must be accurate to dimensions, cut at right angles and even! |
| 3. Tacking of the boards with a length of 250 mm | Place both boards with the right-hand board surface onto the working plane. Put a lath flush onto the cross-cut surfaces and pin!
Do not drive in the nails completely! |
| 4. Determine the nailing points and mark them a pencil | Nailing is done in the form of a triangle according to the work drawing! |
| 5. Nailing of lath and | Put packing blocks of wood between the board and the |

- board according to points 3. and 4.
6. Remove the tacking nails
7. Prepare the nails for clinching.
8. Clinch the nails in the direction of the grain of wood
9. Drive the nail ends into the wood
10. Mark the nailing points at the boards with the dimensions 200 mm and 500 mm
11. Tack the boards of Nos. 5. and 10. so as to produce two nailed comers
12. Nail and pull out the tacking nails
13. Put both nailed corners together, tack and nail them
14. Determine the nailing
- supporting surface and drive the nails at the nailing points vertically through the lath and the board until the nail head is flush with the wood surface!
- Put the nail head surfaces firmly onto the bench top and fasten them with the screw clamp!
- Press the steel bar firmly against the nail shank driven through, then clinch the projecting shank and the nail point at an angle of 90°.
- Take the steel bar off and drive the nails back into the wood like staples until they are flush with the wood surface.
- The nails shall be driven into the narrow surface of the laths and not into the cross-cut wood!
- The board of operation No. 10. with the cross-cut edge being flush and at right angles is put onto the lath (5.) and tacked.
- Drive in the nails vertically and flush with the surface.

14. Determine the nailing points at the bottom and mark them with a pencil

15. Lay in the bottom board and nail

16. Final check

Drive in the nails at an angle alternately towards the left-hand and the right-hand side.

Check with your eyes whether:

- all nail points stick completely in the wood;
- the wood has been nowhere splitted visibly;
- no wood fibres have been torn out.

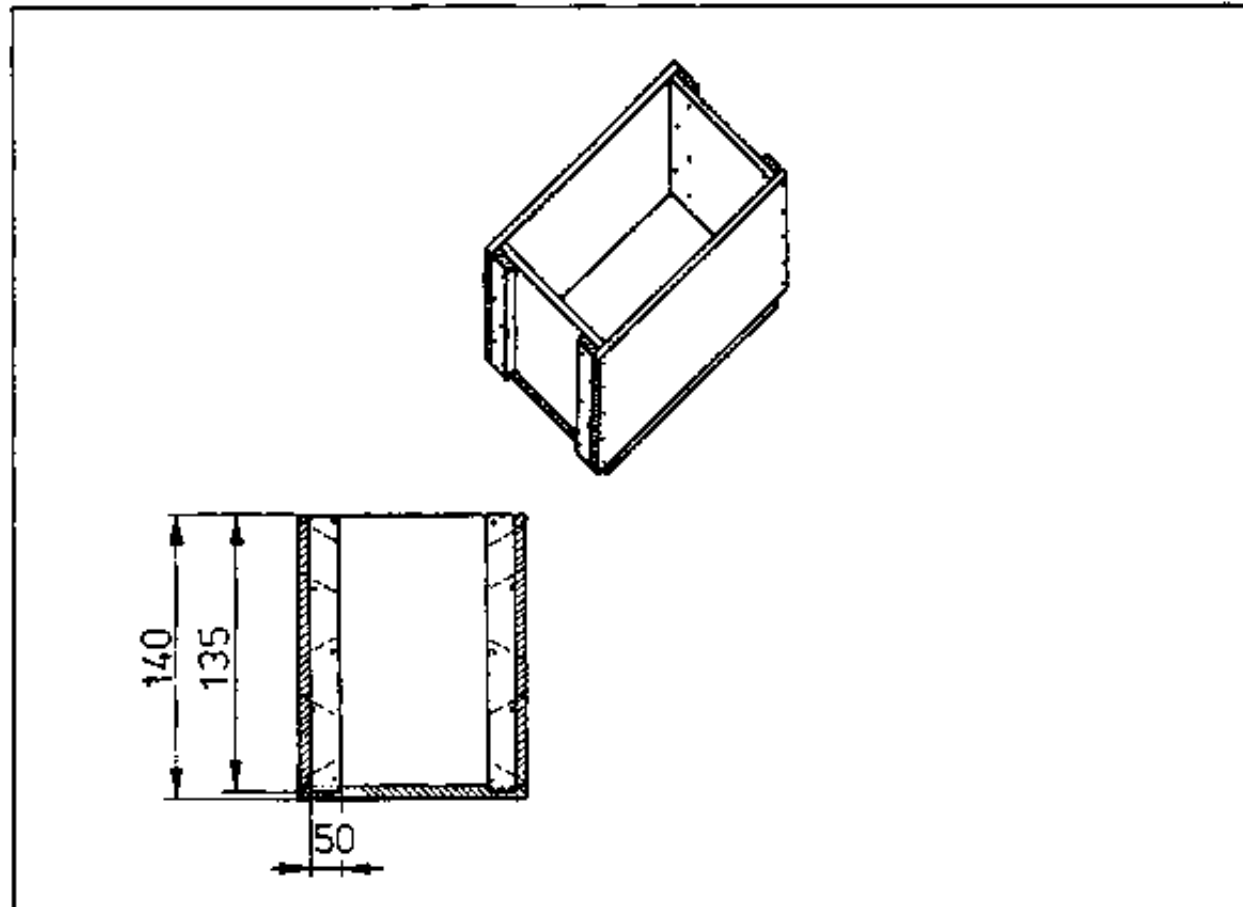

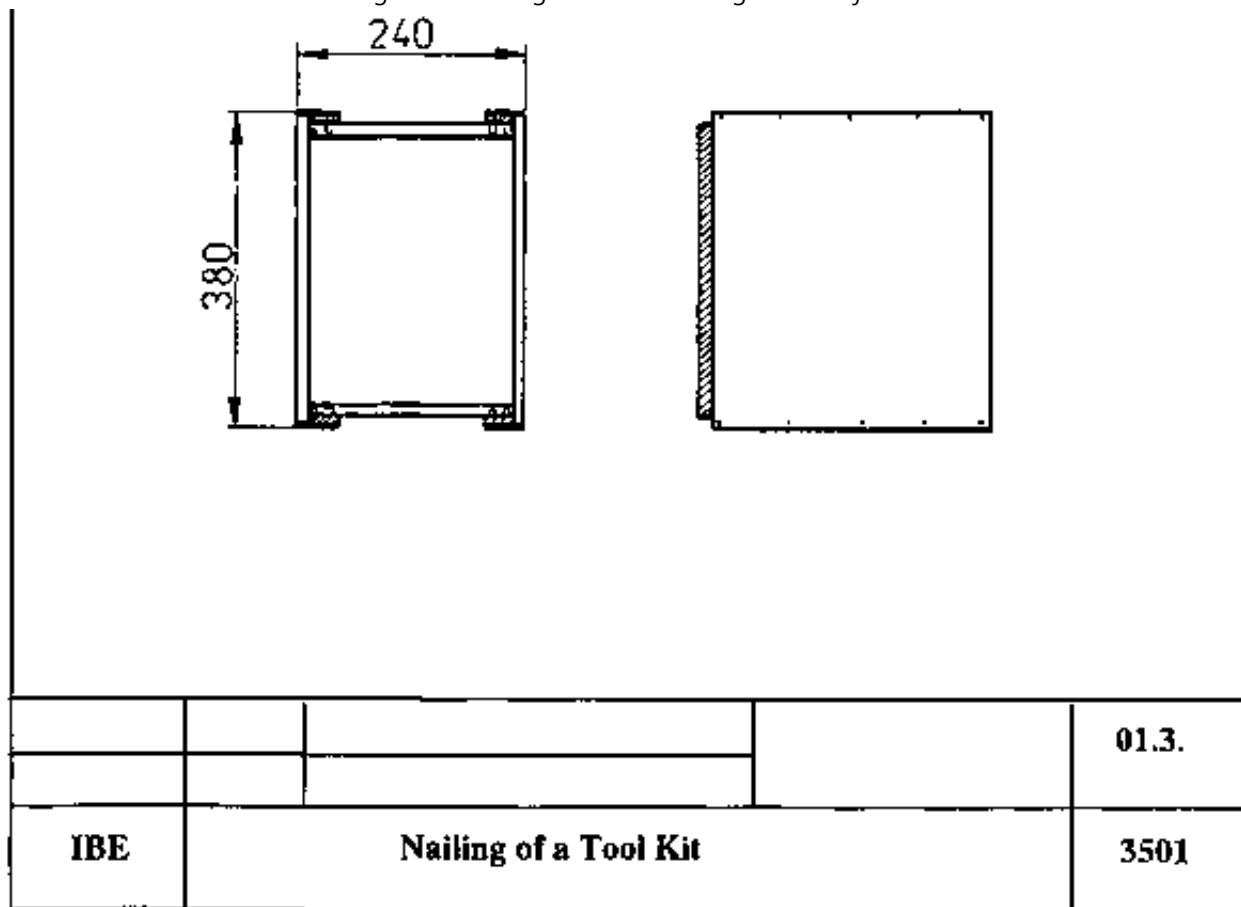

Nailing of a Tool Kit









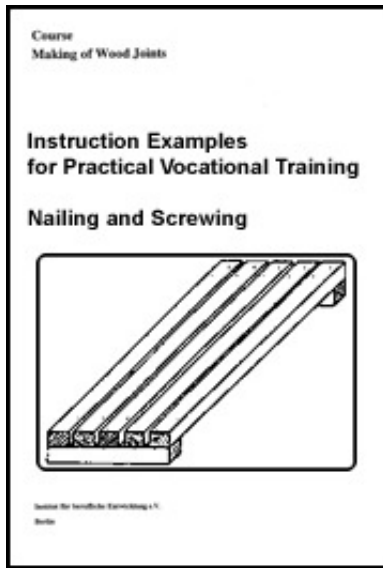

[Home](#) > [ar.cn.de.en.es.fr.id.it.ph.po.ru.sw](#)

 **Nailing and Screwing - Course: Making of wood joints.
Instruction examples for practical vocational training
(Institut fr Berufliche Entwicklung, 29 p.)**

 ***(introduction...)***



-  **Preliminary Remarks**
-  **Instruction Example 01.1. Nailing of a Lath Grid**
-  **Instruction Example 01.2. Nailing of a Halved Frame Corner Joint**
-  **Instruction Example 01.3. Nailing of a Tool Kit**
-   **Instruction Example 01.4. Nailing of a Wall Panel**
-  **Instruction Example 01.5. Screwing of a Carrying Handle on a Tool Kit**
-  **Instruction Example 01.6. Screwing on of a Screw-on Brace**

Instruction Example 01.4. Nailing of a Wall Panel

In this instruction example, the covered nailing is practised (assembly work).

Material

boards

planed, chamfered, groove and tongue shaped, with the following dimensions:

thickness: 18 mm

width without tongue: 80 mm

length: 2600 mm

(for two running metres wall panel: 25 off. The substructure 25 mm thick is evenly fastened to the wall to be panelled),

countersunk-head nails 40 mm long

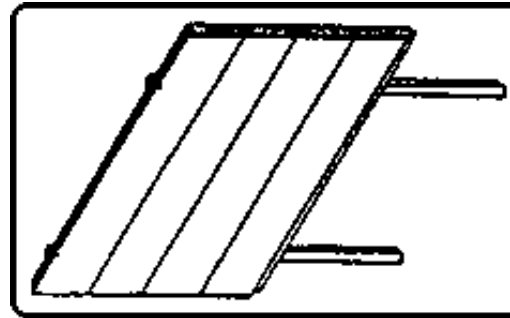

Figure

Tools:

hammer, nail punch, pincers

Measuring and testing means

straightedge, level, plumb line, vernier caliper

Auxiliary means:

spacing strip 15 mm thick, abt. 500 mm long, pencil

Required previous knowledge

reading of the drawing, measuring and scribing, testing

Sequence of operations

Comments

1. Prepare the workplace, sort the Check the completeness of the tools, auxiliary means

boards and make them available, and materials.

check the evenness of the sub-structure according to height and width

2. Determine the reference line for the first board on the left-hand side, the right-hand rear edge and mark it on the sub-structure with a pencil

Check the left-hand side with the level for evenness, apply the first board, mark the right-hand edge, check the vertical position by means of the plumb line, if necessary, correct, then mark on the sub-structure!

3. Put the spacing strip onto the floor and place the first board on it (groove towards the left-hand side, tongue towards the right-hand side)

The spacing strip ensures the ground clearance of the cross-cut surface of the boards.

4. Mark the nailing points on the first board at the left-hand edge with a pencil, nail and drive in the nails with the punch

Fix the nailing points in accordance with the sub-structure. Drive in the nails straightly and sink them with the prick punch!

5. Nailing of the tongue

Drive in the nails at an angle; as for the last centimeter: drive in the nails with the nail punch!

6. Placing and nailing of the next and all following boards

Put the next board onto the spacing strip, joint it with the first one by slight blows with the hammer against the tongue (use a sectional shim block of wood). Nailing as under 5.! Proceed in the same way with all the other boards!

7 Final check

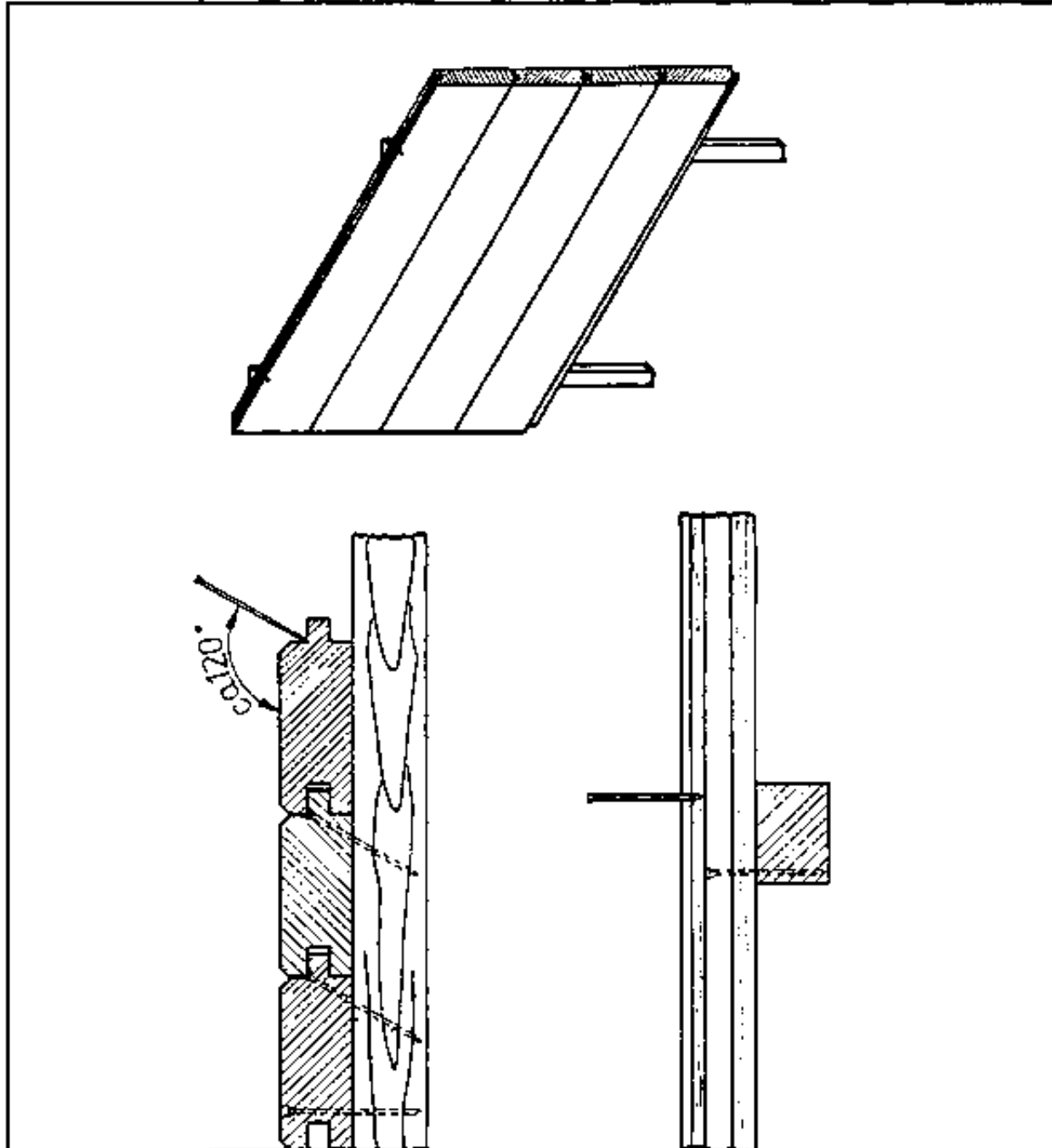

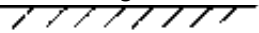
			
			01.4.
IBE	Nailing of a Wall Panel		3501





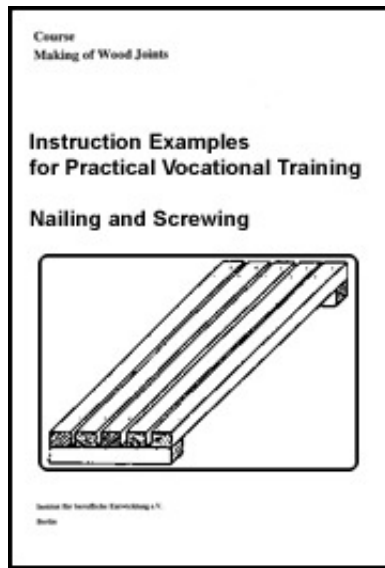

Nailing of a Wall Panel



[Home](#) > [ar](#) [cn](#) [de](#) [en](#) [es](#) [fr](#) [id](#) [it](#) [ph](#) [po](#) [ru](#) [sw](#)



Nailing and Screwing - Course: Making of wood joints. Instruction examples for practical vocational training (Institut für Berufliche Entwicklung, 29 p.)

- 
(introduction...)
- 
Preliminary Remarks
- 
Instruction Example 01.1. Nailing of a Lath Grid
- 
Instruction Example 01.2. Nailing of a Halved Frame Corner Joint
- 
Instruction Example 01.3. Nailing of a Tool Kit
- 
Instruction Example 01.4. Nailing of a Wall Panel
- 
Instruction Example 01.5. Screwing of a Carrying Handle





on a Tool Kit

Instruction Example 01.6. Screwing on of a Screw-on Brace

Instruction Example 01.5. Screwing of a Carrying Handle on a Tool Kit

In this instruction example, the joining of two boards by means of wood screws is practised.

Material

- tool kit from instruction example No. 3
- finished carrying handle, board thickness: 20 mm
- 8 pcs. countersunk-head wood screw 3 x 30 mm

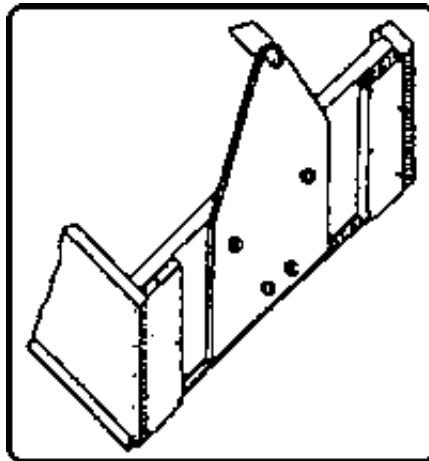

Figure

Tools

screw driver 6 mm, wood drill 2 mm and 3 mm, bit brace with rose bit

Measuring and testing means

back square, folding rule, vernier caliper

Auxiliary means

joiner's bench, screw clamp, pencil

Required previous knowledge

reading of the drawing, measuring and scribing, drilling

Sequence of operations

1. Prepare the workplace, make the working materials available
2. Apply the handle holder according to the drawing and scribe it, determine the screwing points and mark them
3. Bore the handle holder 12 mm deep with the drill 3 mm dia. and ream it, fasten it with the screw clamp to the box according to the scribed line and go on boring and the predrilled holes with the drill

Comments

Check the completeness of tools and materials

The handle holder is situated centrally to the box. The screwing points shall enclose a surface as large as possible, shall be staggered with the grain and have a distance to the edge of about 20 mm!

Fasten the screw clamp so that at least three holes can be drilled without hindrance. Observe the boring depth!

The blade of the screw driver must

4. Screw in the countersunk-head screw with the screw driver

the blade of the screw driver must completely fill the slot in the screws so that it is possible to drive in the screws without damaging the slot and the wood edge!

5. Screw on the second side of the handle holder (see operation 2. to 4.)

6. Final check

When visually checking, take heed of the following:

- the screw heads be must flush with the wood surface
- all screws must be firmly screwed in
- bores and screws must not be through, i.e. they must not be visible on the opposite side!

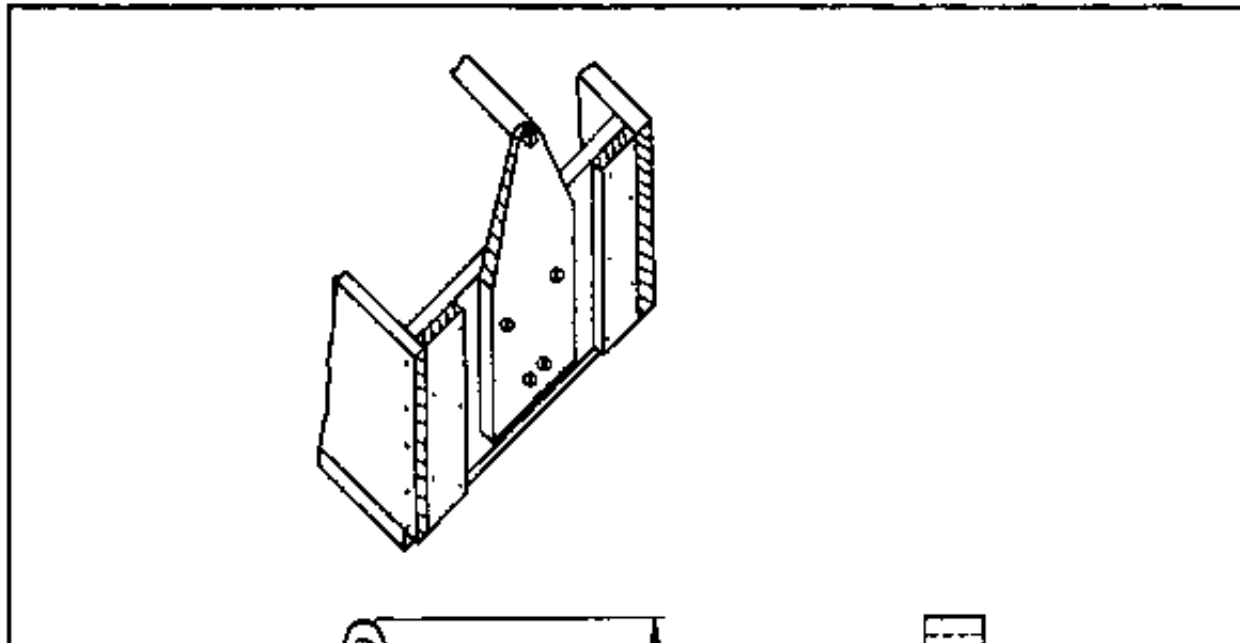

			01.5.
IBE	Screwing of a Carrying Handle to a Tool Kit		3501

Screwing of a Carrying Handle to a Tool Kit



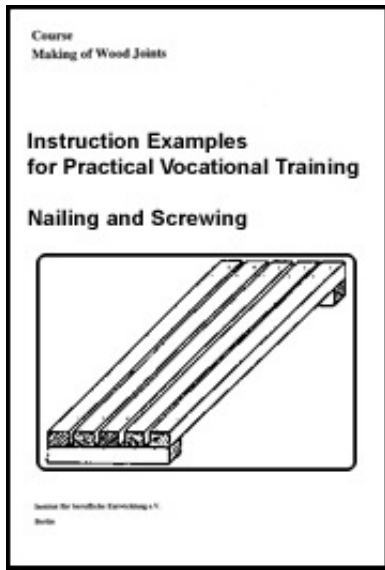



Nailing and Screwing - Course: Making of wood joints. Instruction examples for practical vocational training (Institut für Berufliche Entwicklung, 29 p.)

 **(introduction...)**

 **Preliminary Remarks**

 **Instruction Example 01.1. Nailing of a Lath Grid**

 **Instruction Example 01.2. Nailing of a Halved Frame Corner Joint**

 **Instruction Example 01.3. Nailing of a Tool Kit**

 **Instruction Example 01.4. Nailing of a Wall Panel**

 **Instruction Example 01.5. Screwing of a Carrying Handle on a Tool Kit**

 **Instruction Example 01.6. Screwing on of a Screw-on Brace**

Instruction Example 01.6. Screwing on of a Screw-on Brace

In this instruction example, the fastening of a door hinge to a board leaf by means of countersunk-head wood screws and round-head bolts is practised.

Material

1 plank door leaf

2 screw-on braces with screw holes 6.4 mm dia. and a punched hole for each screw hole of 8.4 mm dia.

6 off round-headed wood screws dia. 6 x 50 mm

2 off round-head bolts with square neck M 8 x 60 mm with washers and nuts

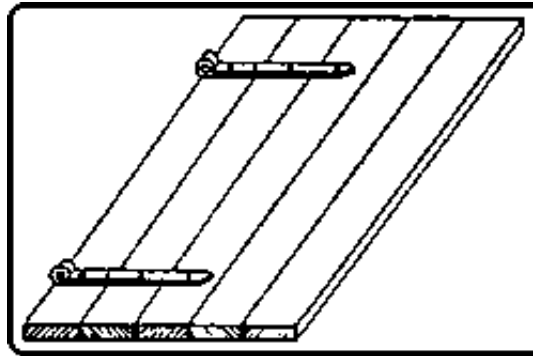

Figure

Tools

screw driver 12 mm, wood drills 4; 6; 8 mm, screw wrench 13 mm

Auxiliary means

joiner's bench, support, pencil

Required previous knowledge

reading of the drawing, measuring and scribing, drilling

Sequence of operations

1. Prepare the workplace, make the working materials available

Comments

Check the completeness of the required tools and materials, put the door leaf onto the joiner's bench and support!

The screw or bolts are centrally aligned above the

2. Put on the braces to be screwed on, align and mark the screw bores with a pencil

The screw-on braces are centrally aligned above the crosspieces which hold the board cover and are screwed on. The required projecting length of the idler is to be observed/Check the proper position of the screwed on braces with a large back square!

3. Remove the screw-on braces, bore the screw holes

Drill through the 1st hole after the idler with a drill 8 mm, further holes are pre-drilled with a drill 6 mm, 20 mm deep, then bore 20 mm deeper with a drill 4 mm!

4. Put on the screw-on brace, insert the round-head bolts and fasten them with washers and nuts, drive in the wood screws with the screw driver

Tighten the nuts with a screw wrench. The washer shall be pressed 1 mm into the wood. Firmly tighten the wood screws but do not overturn them!

5. Final check

The long braces fit tightly to the wood, all screws are tightened, not overturned and not sheared off, bores for the wood screws are not visible on the inside of the door!

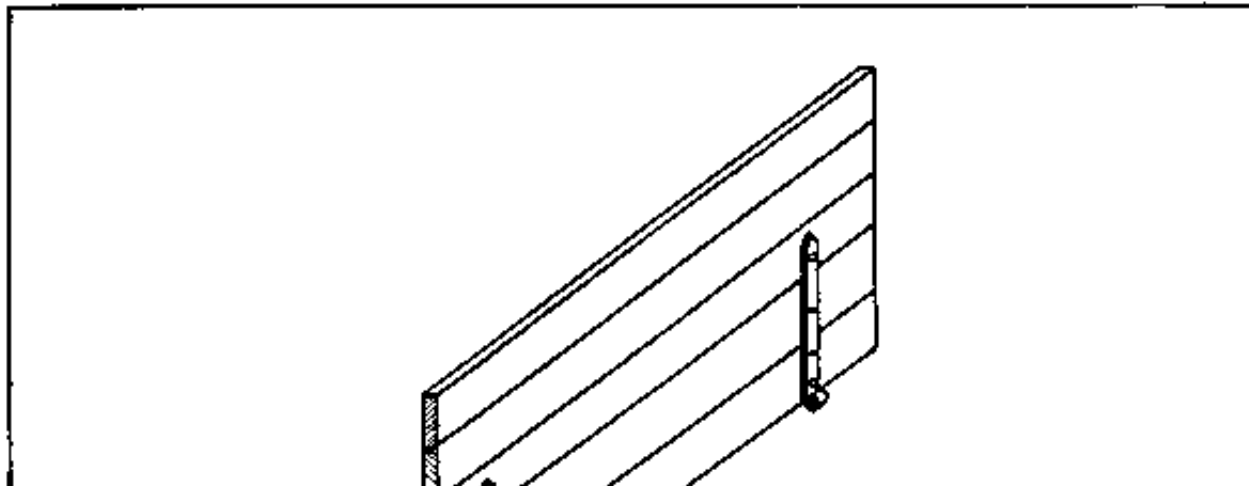

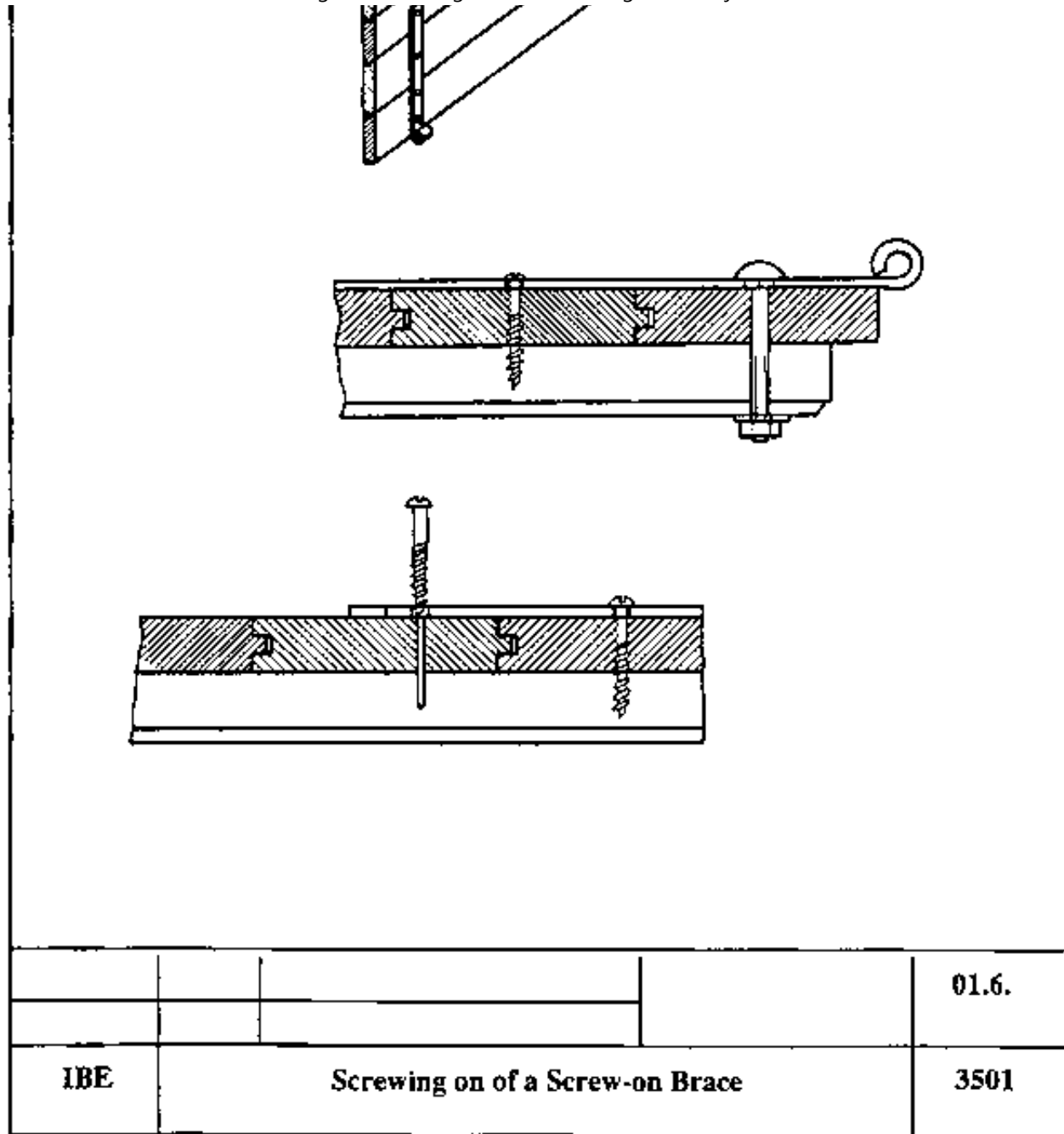

Screwing on of a Screw-on Brace

