

**Operations on Smooth Miller and Thicknessing Miller – Course:  
Mechanical woodworking techniques. Instruction examples for  
practical vocational training**



# Table of Contents

<b><u>Operations on Smooth Miller and Thicknessing Miller – Course: Mechanical woodworking techniques. Instruction examples for practical vocational training</u></b> .....	1
<u>Preliminary Remarks</u> .....	1
<u>Instruction Example 2.1.: Frame Piece</u> .....	1
<u>Instruction Example 2.2.: Frame Piece</u> .....	3
<u>Instruction Example 2.3.: Frame Piece</u> .....	4
<u>Instruction Example 2.4.: Grating</u> .....	5
<u>Instruction Example 2.5.: Wall Shelf</u> .....	7
<u>Instruction Example 2.6.: Frame</u> .....	10



# Operations on Smooth Miller and Thicknessing Miller – Course: Mechanical woodworking techniques. Instruction examples for practical vocational training

Institut für berufliche Entwicklung e.V.  
Berlin

Original title:  
Lehrbeispiele für die berufspraktische Ausbildung  
“Arbeiten an Abricht- und Dickenfräsmaschinen”

Author: Johannes Schollbach

First edition © IBE

Institut für berufliche Entwicklung e.V.  
Parkstraße 23  
13187 Berlin

Order No.: 93–33–3402/2

## Preliminary Remarks

This material contains six selected instruction examples which are useful for applying and improving knowledge in the field of the working techniques of milling broad and narrow faces as well as of milling to thickness and width.

In order to facilitate preparations and operations, the necessary materials, machines, measuring and testing means as well as auxiliaries are specified for each instruction example.

Furthermore, the previous knowledge is mentioned that is additionally necessary for milling broad and narrow faces as well as for milling to thickness and width. It is recommended to repeat this knowledge before starting the work.

The sequence of operations specified for each instruction example includes working steps leading to the manufacture of the relevant workpiece. This order is to be absolutely observed for reaching a good quality.

A working drawing is attached to each instruction example showing the required shapes and dimensions of the workpiece. It is also possible to choose other practising pieces with smaller or bigger dimensions.

## Instruction Example 2.1.: Frame Piece

The broad face of a ledge is milled to a plane surface.

### Material

Sawn timber

Dimensions:

Length      1000 mm

Width        60 mm

Thickness    45 mm

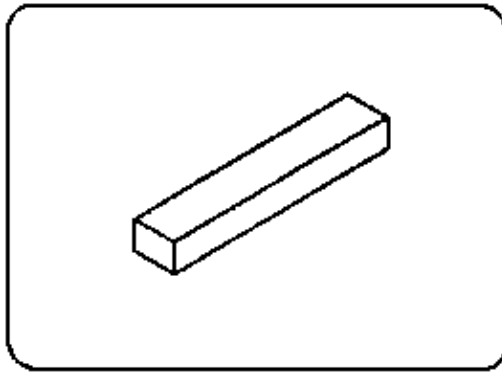
**Machine**

Smooth miller

**Measuring and testing means**

Folding rule

**Required previous knowledge**

Reading of drawings, measuring and testing, "Manual Woodworking Techniques – Planing a Narrow Face by Hand".

<b>Sequence of operations</b>	<b>Comments</b>
1. Set working width, set depth of cut and place frame pieces at disposal.	Check safety devices.
2. Switch on the machine.	Take notice of star–delta connection or direct connection. Make use of ear protectors.
3. Mill the frame piece on its broad face by hand.	Take notice of existing roughness of the broad face when guiding the workpiece. Shift the pressure step by step to the unloading table.
4. Check the milled broad face.	Check two machined workpieces by laying one on the top of the other. The broad faces must sit closely on top of one another.
5. Switch off the machine.	Possible addition: Mill wooden parts of different dimensions on their broad faces.

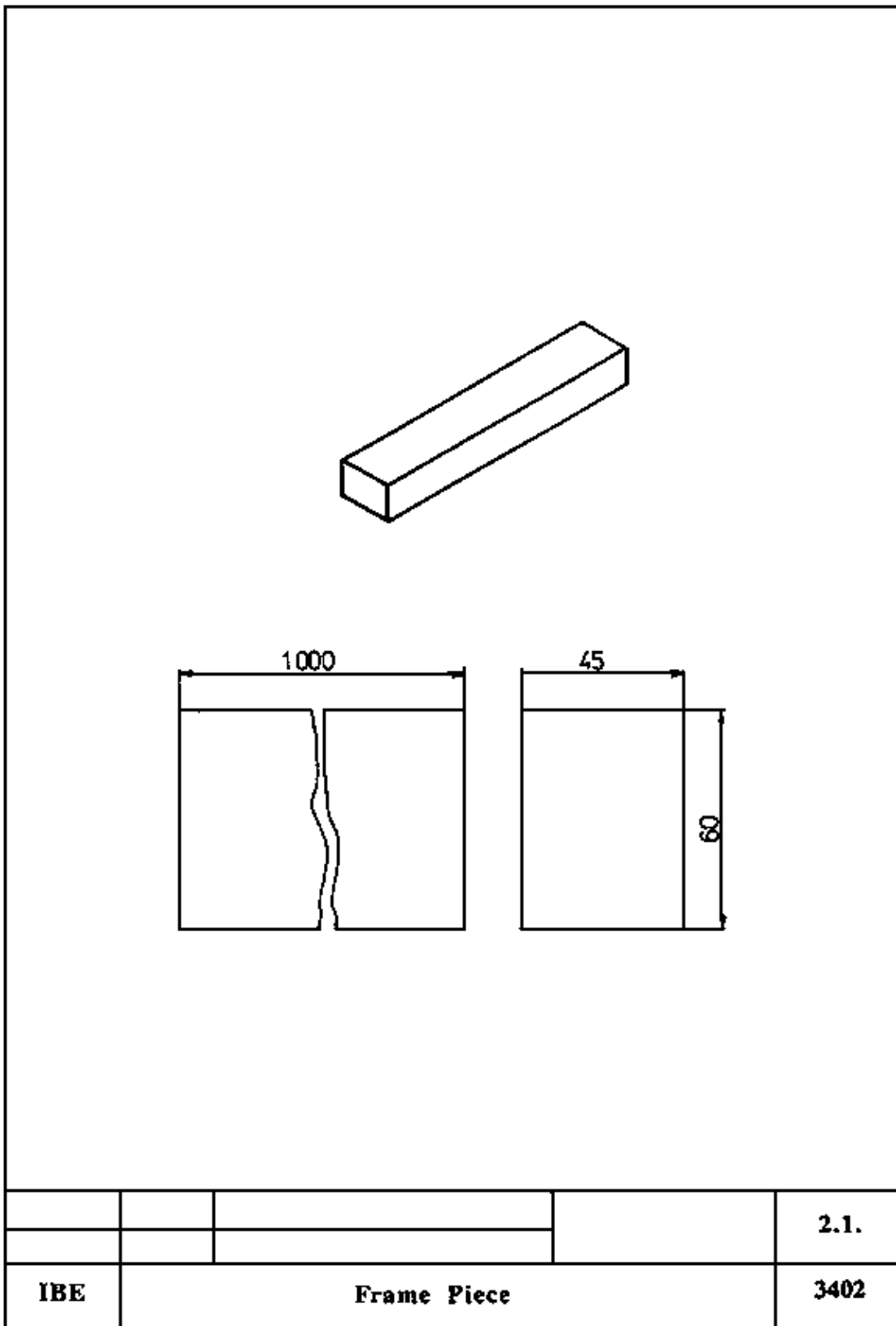

Frame Piece

### Instruction Example 2.2.: Frame Piece

The narrow face of a ledge (see Instruction Example 2.1) is milled at an angle of 90° to the broad face.

#### Material

Machined ledge from Instruction Example 2.1.

### **Machine**

Smooth miller

### **Measuring and testing means**

Solid steel squares, folding rule

### **Necessary previous knowledge**

Reading of drawings, measuring and testing, "Manual Woodworking Techniques – Planing a Narrow Face by Hand".

<b>Sequence of operations</b>	<b>Comments</b>
1. Set working width, set depth of cut, place material at disposal.	Check the safety devices, check the angle of the stop rule.
2. Switch on the machine.	Take notice of star–delta connection or direct connection, wear ear protectors.
3. Mill the frame piece on its narrow face guiding at the stop rule by hand.	The frame piece must closely sit with its broad face at the stop rule.
4. Check the milled narrow face.	The narrow face must be in the required angle to the broad face, lay one narrow face on top of the other, both must sit closely.
5. Switch off the machine.	Possible addition: Mill wooden parts of different dimensions on their narrow faces.

## **Instruction Example 2.3.: Frame Piece**

The surface of the ledge from the preceding Instruction Examples are milled to thickness.

### **Material**

Machined ledge from Instruction Example 2.2.

### **Machine**

Thickening miller

### **Measuring and testing means**

Folding rule, vernier caliper

### **Necessary previous knowledge**

Milling of surfaces on the smooth miller, reading of the drawing, measuring and testing, "Manual Woodworking Techniques – Planing the Broad and Narrow Faces by Hand".

<b>Sequence of operations</b>	<b>Comments</b>
1. Place the material at disposal, set the sizes on the scale of the machine.	Check rebound protection for functionality.
2. Switch on the machine.	Take notice of star–delta connection or direct connection, wear ear protectors.



3. Insert the frame piece up to the draw-in roller by hand.
4. Check the machined workpieces for dimensional accuracy.
5. Switch off the machine.

Put the workpiece with that face on the table, which has been machined on the smooth miller.

Undertake dimensional inspection, using the folding rule or vernier caliper.

Possible addition: Mill workpieces of different dimensions to thickness.

## Instruction Example 2.4.: Grating

For producing ledges for a grating, milling of broad and narrow faces on the smooth and thicknessing miller is to be practised.

### Material

4 x sawn timber

Dimensions:

Length 1000 mm

Width 80 mm

Thickness 25 mm

2 x sawn timber

Dimensions:

Length 450 mm

Width 60 mm

Thickness 25 mm

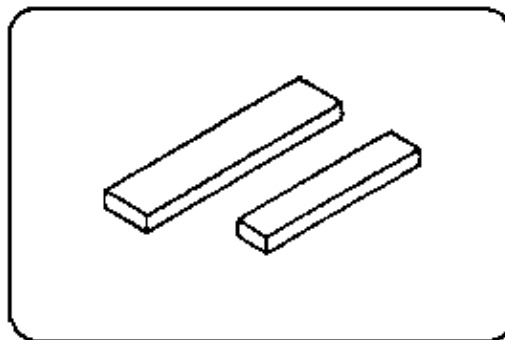

### Machines

Smooth miller, thicknessing miller

### Measuring and testing means

Solid steel squares, folding rule, vernier caliper

### Auxiliary

Feeding device

### Necessary previous knowledge

Reading of drawings, measuring and testing “Manual Woodworking Techniques – Planing the Broad and Narrow Faces by Hand”.

<b>Sequence of operations</b>	<b>Comments</b>
1. Place material at disposal, set working width and depth of cut on the smooth miller.	Check the safety devices.
2. Switch on the machine, mill a broad and a narrow surface.	Take notice of surface roughness when guiding the workpiece. When milling the short ledge, make use of the feeding device.
3. Check the milled surfaces.	Check flatness of the broad face and angularity of the narrow face.
4. Set the thicknessing miller to the required size.	Take into account maximum chip removal.
5. Switch on the machine and mill the ledges to the required thickness and width.	Do not put in workpieces of quite different thickness side by side.
6. Control dimensional accuracy.	Dimensional inspection with folding rule or vernier caliper.
7. Completion: Saw the ledge to the given length. Smooth off comers with abrasive paper. Join the ledges by bolted or nail connection.	

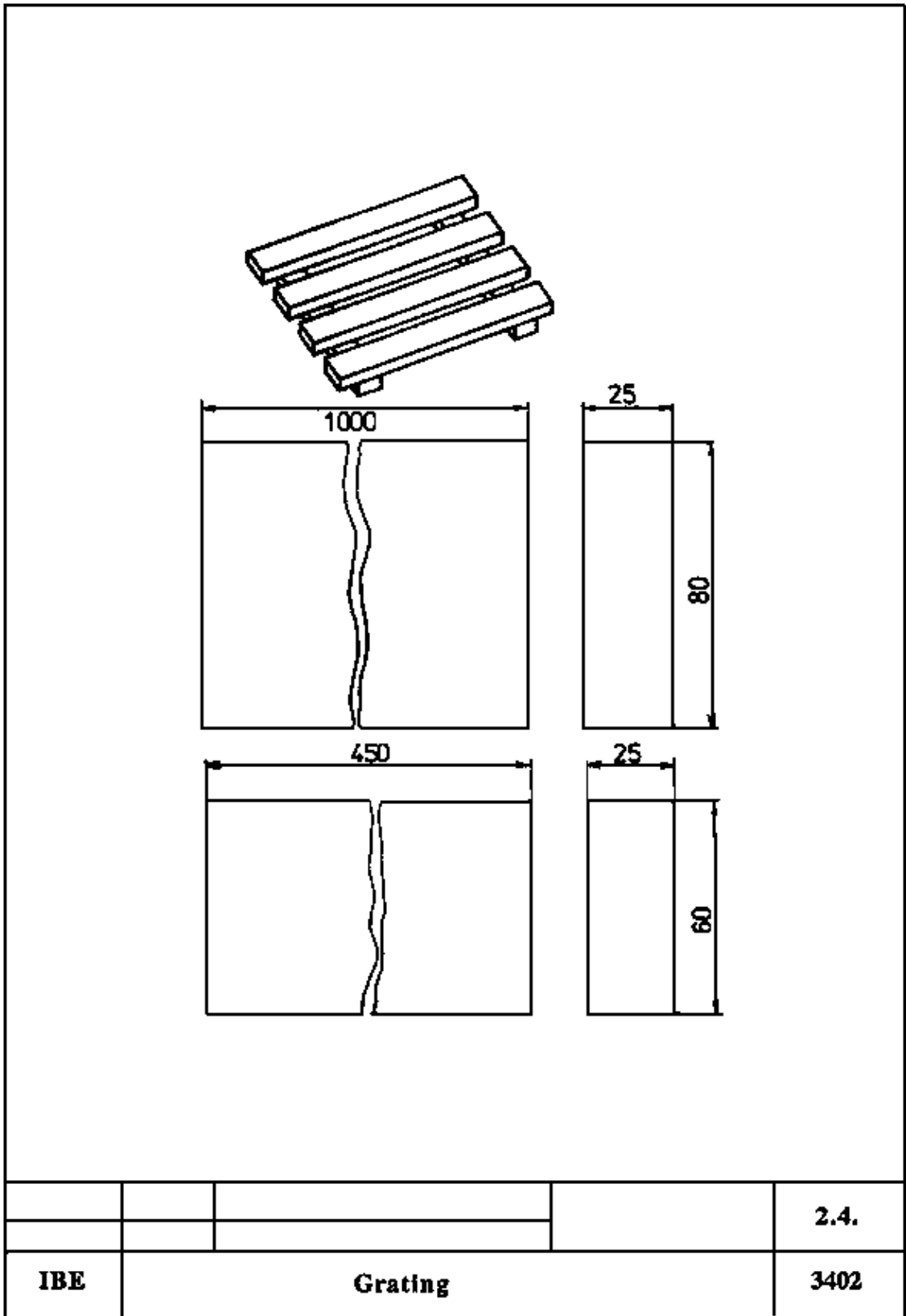

Grating

### Instruction Example 2.5.: Wall Shelf

Practise milling of broad and narrow faces on the smooth miller.

Practise milling to thickness and width on the thicknessing miller for producing piece parts for a wall shelf.

## Material

– Sawn timber

Dimensions:

Length 800 mm

Width 200 mm

Thickness 25 mm

– 2 x sawn timber

Dimensions:

Length 400 mm

Width 190 mm

Thickness 25 mm

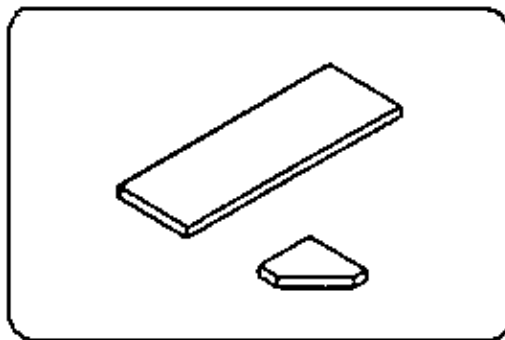

## Machines

Smooth miller, thicknessing miller

## Measuring and testing means

Solid steel squares, folding rule, vernier caliper

## Auxiliary

Feeding device

## Necessary previous knowledge

Reading drawings, measuring and testing “Manual Woodworking Techniques – Planing the Broad and Narrow Faces by Hand”.

### Sequence of operations

1. Place the material at disposal, set the working width and the depth of the cut on the smooth miller.
2. Mill a broad and a narrow face.
3. Control the broad and the narrow face.

### Comments

- Check the safety devices, make use of the ear protector.
- Take notice of surface roughness when guiding the workpiece. Make use of the feeding device.
- Check flatness of the broad face and angularity of the narrow face.

4. Set the thicknessing miller to the required dimension. Switch on the machine and mill the workpiece to thickness and width.

5. Control dimensional accuracy.

6. Completion:

Mark the piece parts according to the drawing and cut them to size. Smooth off edges and comers. Join supports and shelf by bolted connection and flat comer joint.

Take into account maximum chip removal. Do not put in workpieces which are of quite different thickness, side by side.

Dimensional inspection with folding rule or vernier caliper.

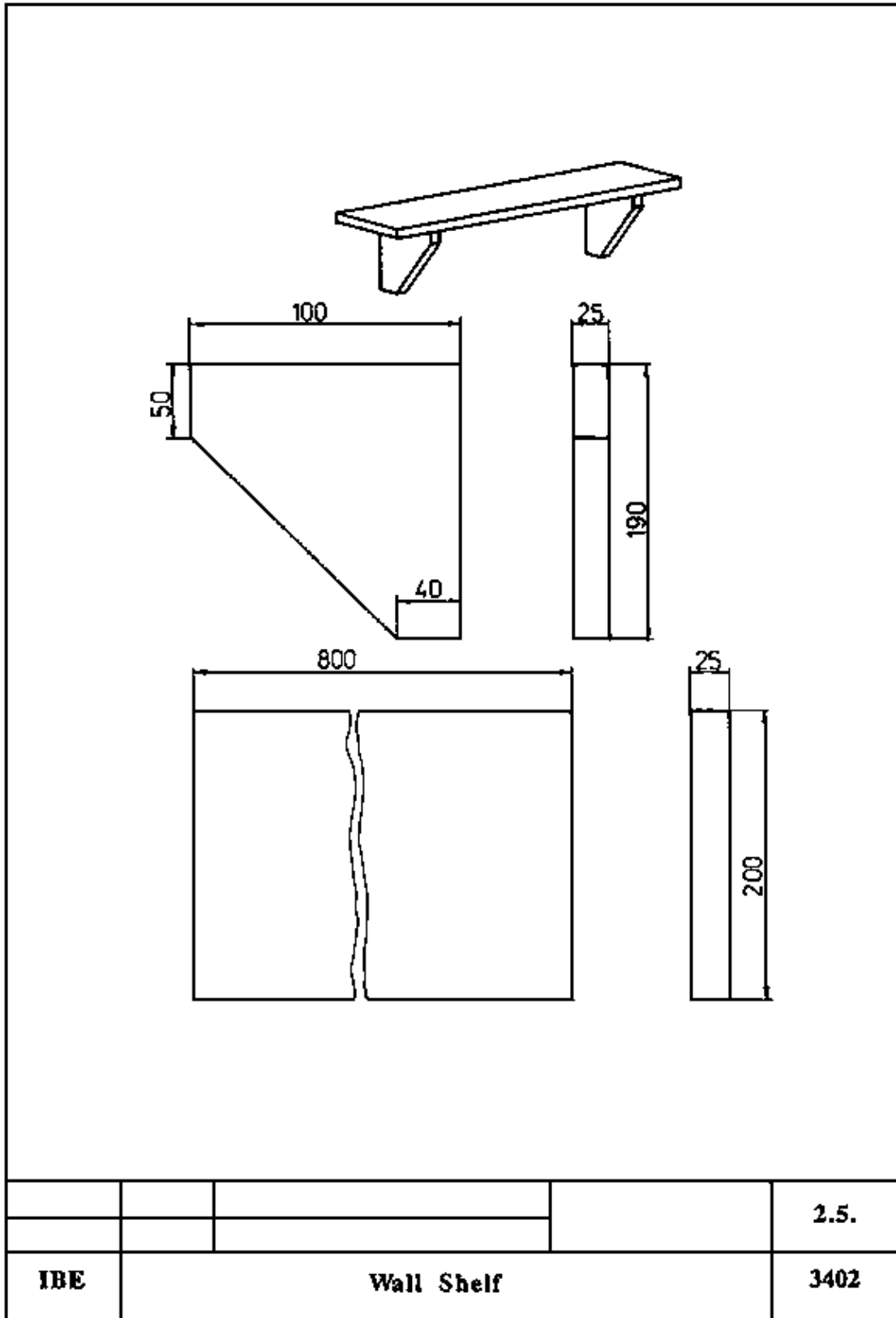

Wall Shelf

### Instruction Example 2.6.: Frame

Practise milling of broad and narrow faces on the smooth miller.

Practise milling to thickness and width on the thicknessing miller for producing frame ledges.

## Material

– 2 x sawn timber

Dimensions:

Length 2000 mm

Width 120 mm

Thickness 35 mm

– 2 x sawn timber

Dimensions:

Length 900 mm

Width 120 mm

Thickness 35 mm

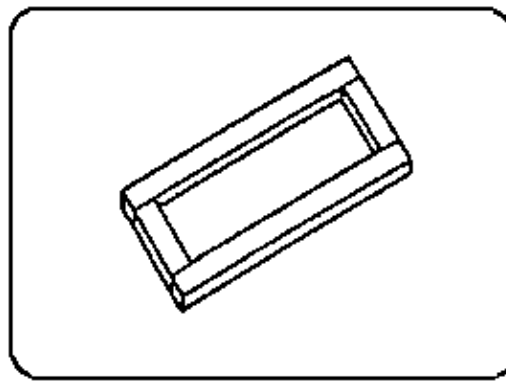

## Machines

Smooth miller

## Measuring and testing means

Solid steel squares, folding rule, vernier caliper.

## Necessary previous knowledge

Reading drawings, marking, measuring and testing, making a slotted frame connection, pasting together connections.

Sequence of operations	Comments
1. Place the material at disposal, set the smooth miller.	Check the thickness of the strip scutter, visual checking or mill a test piece.
2. Mill a broad and a narrow face.	Long workpieces require special skill for milling, do not give too much pressure to avoid deflection.
3. Control the milled broad and narrow face.	Check flatness of the broad face and angularity of the narrow face.
4. Mill to width and thickness on the thicknessing miller.	Take notice of surface roughness when guiding the workpiece.

5. Control of dimensional accuracy.

Dimensional inspection with folding rule or vernier caliper.

6. Completion:

Piece parts are to be sawn to length according to the drawing. Mark the slotted frame connection and carry out. Paste together the connection. Smooth the surfaces of the frame. Smooth off edges.

				<b>2.6.</b>
<b>IBE</b>	<b>Frame</b>			<b>3402</b>

Frame



**Nailing and Screwing – Course: Making of wood joints. Instruction examples for practical vocational training**



# Table of Contents

<b><u>Nailing and Screwing – Course: Making of wood joints. Instruction examples for practical vocational training</u></b> .....	<b>1</b>
<u>Preliminary Remarks</u> .....	1
<u>Instruction Example 01.1. Nailing of a Lath Grid</u> .....	2
<u>Instruction Example 01.2. Nailing of a Halved Frame Corner Joint</u> .....	4
<u>Instruction Example 01.3. Nailing of a Tool Kit</u> .....	6
<u>Instruction Example 01.4. Nailing of a Wall Panel</u> .....	9
<u>Instruction Example 01.5. Screwing of a Carrying Handle on a Tool Kit</u> .....	12
<u>Instruction Example 01.6. Screwing on of a Screw-on Brace</u> .....	14



# **Nailing and Screwing – Course: Making of wood joints. Instruction examples for practical vocational training**

**Institut für berufliche Entwicklung e.V.  
Berlin**

Original title:

Lehrbeispiele für die berufspraktische Ausbildung  
"Nageln und Schrauben"

Author: Harald Stelzer

First edition © IBE

Institut für berufliche Entwicklung e.V.  
Parkstraße 23  
13187 Berlin

Order No.: 93–33–3501/2

## **Preliminary Remarks**

The present documentation contains six selected instruction examples which serve to apply and consolidate the knowledge and skills of nailing and screwing techniques.

The basic idea of this technique is the making of wood joints, as well as the fastening of mountings on wood by means of nails or screws.

Each of the six selected instruction examples offers different possibilities to make wood joints or fasten mountings by means of nails or screws for holding or securing the parts to be joined.

The following criteria are to be considered:

- kind and extent of load the joint is exposed to
- durability
- optical–aesthetical appearance
- risk of injury.

The kinds of joints offered in the instruction examples can be practised on other workpieces as well depending on the requirements of the trainee's working range and/or factory.

This could be for example:

- fastening of floor boarding, rear walls of furniture
- assembly of picket fences, batten doors and plank doors, transport boxes
- mounting on furniture and structural wood members, makeshift furniture.

To facilitate the preparation and implementation of the works, the materials, tools, measuring, testing and auxiliary means required for each instruction example are stated.

The work routine mentioned for the individual instruction examples contains the sequence of operations which are necessary for making the nail and/or screw joint.

A work drawing is attached to each example which shows the type and arrangement of the nails or screws as well as the shapes and/or dimensions of the workpiece.

## Instruction Example 01.1. Nailing of a Lath Grid

In this instruction example, nailing in long wood is practised.

### Material

7 laths

thickness: 25 mm

width: 40 mm

length: 600 mm

2 crosspieces

thickness: 45 mm

width: 50 mm

length: 400 mm

Medium-firm wood

Countersunk-head nails 60 mm long

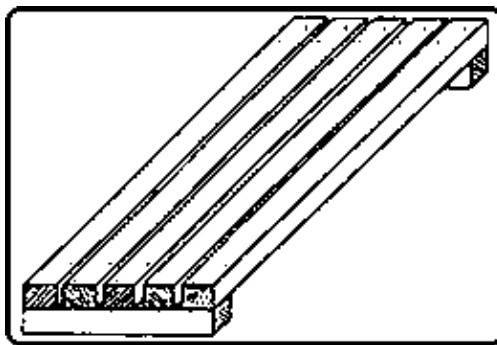

### Tools:

hammer, nail punch, pincers

### Measuring and testing means:

back square, folding rule, vernier caliper

### Auxiliary means:

spacing strip 20 mm thick, 20 mm wide, 600 mm long; firm, non-springy bench top at working height; pencil

### Required previous knowledge

reading of drawings, measuring and scribing

### Sequence of operations

1. Prepare the workplace, make the working materials available

2. Mark the outer edges of the cross members on the working plane

3. Put the laths together, determine the nailing points and mark them with a pencil

4. Nail the rear lath

### Comments

Check the completeness of tools and materials!

Put both crosspieces at a distance of 500 mm (inside) in parallel to each other on the working plane and mark the outer edges on the working plane with a pencil.

When fixing the nailing points, observe the required distances from the edge so as to avoid splitting of the wood!

Put the rear lath flush onto the crosspieces. First, drive in one nail on each side, check the angularity, if necessary, correct it, then drive in the

second nail on each side. Prior to this, the nails are to be upset!

5. Pin the front lath  
Put the front lath flush on the cross members and pin it. Do not drive in the nails completely!
6. Nailing of all the other laths  
Put the spacing strip against the rear lath, put the next lath flush onto the crosspieces and nail. Proceed in the same way with all the other laths.
7. Nailing of the front lath  
Draw out the tack nails at the front lath, place the lath so that it is flush, upset the nails and nail!
8. Driving in of the nail heads  
Drive in the nail heads means by of a hammer and a nail punch. It is sunk abt. 3 mm deep.
9. Final check  
Visual check: check angularity, check whether the distances between the laths are all the same! The laths and crosspieces must not be splitted visibly, the nails must completely stick in the wood!

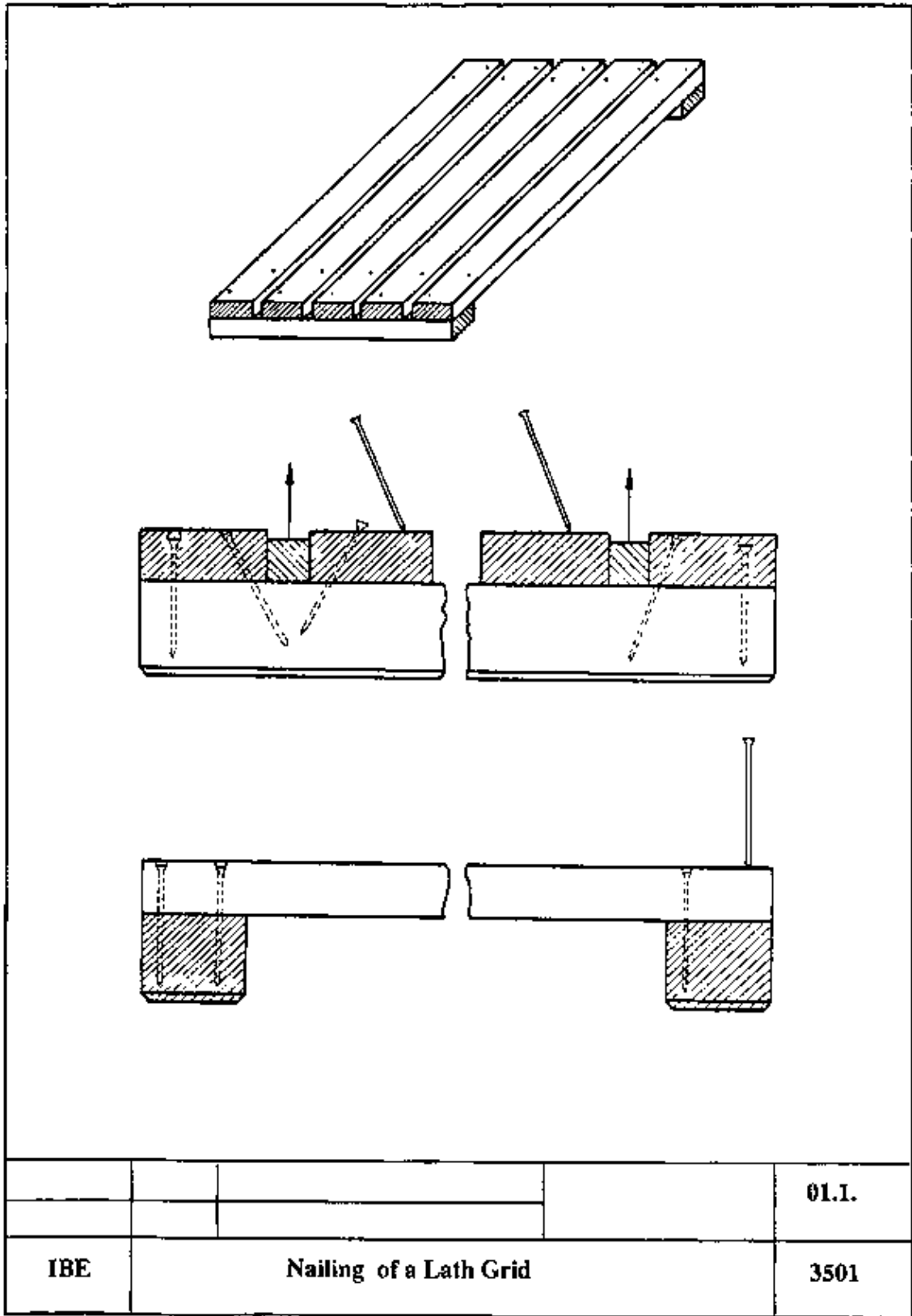

Nailing of a Lath Grid

### Instruction Example 01.2. Nailing of a Halved Frame Corner Joint

In this instruction example, nailing of a glued frame corner joint with clinched nails is practised.

#### Material



halved frame corner joint, glued,  
thickness of the legs: 26 mm  
width of the legs: 50 mm  
countersunk-head nails 30 mm long, unhardened

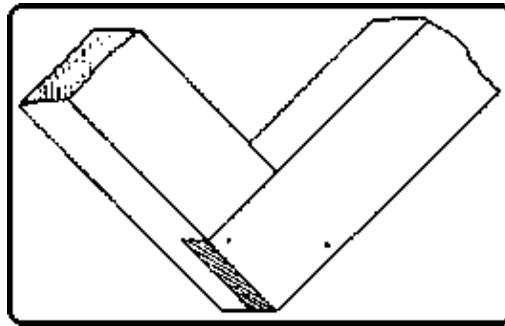

### Tools

hammer, pincers

### Measuring and testing means

back square, folding rule, vernier caliper

### Auxiliary means

unhardened steel plate, 200 x 200 mm, 10 mm thick, as base plate; firm, non-springy bench top at working height (joiner's bench); pencil

### Required previous knowledge

reading of the drawing, measuring and scribing

#### Sequence of operations

#### Comments

- |   |  |
|---|--|
| 1. Prepare the workplace, make tools and working materials available. | Check the completeness of tools and materials!   |
| 2. Determine the nailing points and mark them with a pencil.          | Observe the required distance from the edge, adhere to the nail picture according to the work drawing!   |
| 3. Fasten the frame in preparation of nailing                         | Place the steel plate (base plate) at the endscrew onto the joiner's bench, put on the frame corner and clamp it between the cramp irons, fasten the frame corner with a screw clamp to the bench plate!   |
| 4. Drive in the nails at the nailing points                           | Observe the inclined position of the nails, the nail points must show in the direction of the grain of the lower surface. Drive in the nails with precise blows until the nail heads are flush with the wood surface.  |
| 5. Unclamp the frame corner   | Loosen the endscrew, undo the screw clamp.   |
| 6. Final check  | Check: <ul style="list-style-type: none"> <li>– for proper inclined position of the nails</li> <li>– whether the wood surface is not deformed by the blows with the hammer</li> <li>– whether the nail heads are flush with the wood surface</li> <li>– whether the nail points are properly clinched and entirely driven into the wood</li> <li>– for splitting of the wood and torn out wood fibres</li> </ul> |

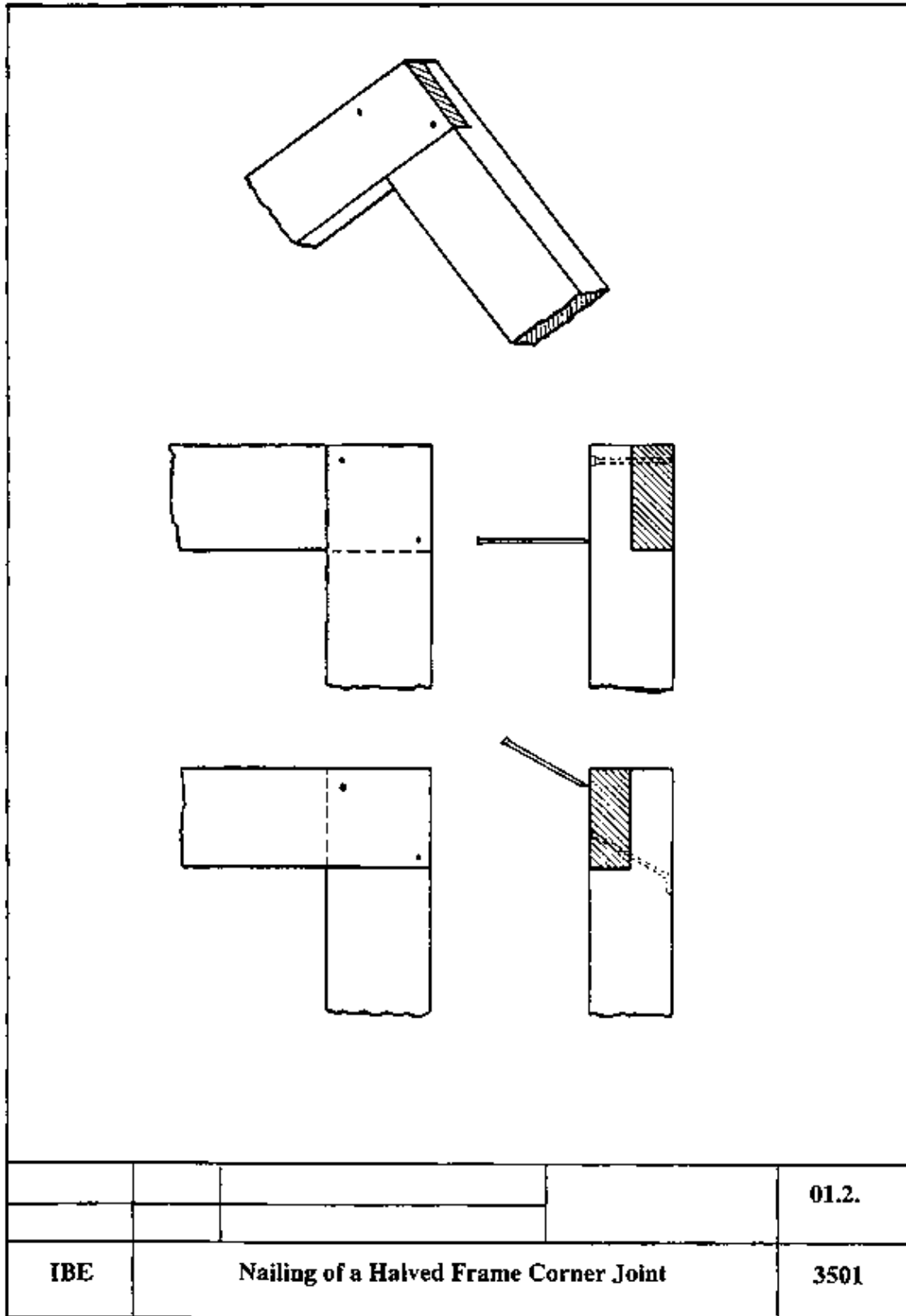

Nailing of a Halved Frame Corner Joint

### Instruction Example 01.3. Nailing of a Tool Kit

In this instruction example, the simple nailing techniques in long wood and nailing with overlong nails are practised.

#### Material

2 boards  
 thickness: 14 mm  
 width: 200 mm  
 length: 500 mm  
 2 boards  
 thickness: 14 mm  
 width: 200 mm  
 length: 250 mm  
 1 bottom board  
 thickness: 14 mm  
 width: 278 mm  
 length: 468 mm  
 4 laths  
 thickness: 16 mm  
 width: 40 mm  
 length: 210 mm  
 countersunk–head nails 45 mm long.

The complete wood is planed out, surface–shaped and cut to size.

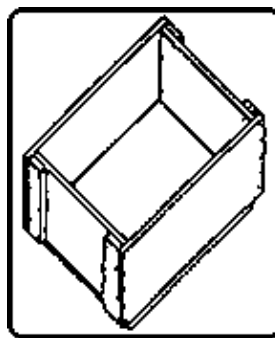

### Tools

hammer, pincers

### Measuring and testing means

back square, folding rule, vernier caliper

### Auxiliary means

firm, non–springy bench top at working height (joiner's bench), steel bar 20 x 10 mm, 300 mm long, packing blocks of wood 25 mm thick, tacking nails 25 mm long, screw clamp 200 mm

### Required previous knowledge

reading of the drawing, measuring and scribing

#### Sequence of operations

1. Prepare the workplace, make the working materials available.
2. Check the material for accuracy to size and angularity.
3. Tacking of the boards with a length of 250 mm
4. Determine the nailing points and mark them a pencil

#### Comments

- Check the completeness of tools an materials!
- All boards must be accurate to dimensions, cut at right angles and even!
- Place both boards with the right–hand board surface onto the working plane. Put a lath flush onto the cross–cut surfaces and pin!  
Do not drive in the nails completely!
- Nailing is done in the form of a triangle according to the work drawing!

- |   |  |
|---|--|
| 5. Nailing of lath and board according to points 3. and 4.                      | Put packing blocks of wood between the board and the supporting surface and drive the nails at the nailing points vertically through the lath and the board until the nail head is flush with the wood surface!                      |
| 6. Remove the tacking nails   |  |
| 7. Prepare the nails for clinching.   | Put the nail head surfaces firmly onto the bench top and fasten them with the screw clamp!   |
| 8. Clinch the nails in the direction of the grain of wood                       | Press the steel bar firmly against the nail shank driven through, then clinch the projecting shank and the nail point at an angle of 90°.  |
| 9. Drive the nail ends into the wood  | Take the steel bar off and drive the nails back into the wood like staples until they are flush with the wood surface.   |
| 10. Mark the nailing points at the boards with the dimensions 200 mm and 500 mm | The nails shall be driven into the narrow surface of the laths and not into the cross-cut wood!  |
| 11. Tack the boards of Nos. 5. and 10. so as to produce two nailed comers       | The board of operation No. 10. with the cross-cut edge being flush and at right angles is put onto the lath (5.) and tacked.   |
| 12. Nail and pull out the tacking nails   | Drive in the nails vertically and flush with the surface.  |
| 13. Put both nailed corners together, tack and nail them                        |  |
| 14. Determine the nailing points at the bottom and mark them with a pencil      |  |
| 15. Lay in the bottom board and nail  | Drive in the nails at an angle alternately towards the left-hand and the right-hand side.  |
| 16. Final check   | Check with your eyes whether: <ul style="list-style-type: none"> <li>- all nail points stick completely in the wood;</li> <li>- the wood has been nowhere splitted visibly;</li> <li>- no wood fibres have been torn out.</li> </ul> |

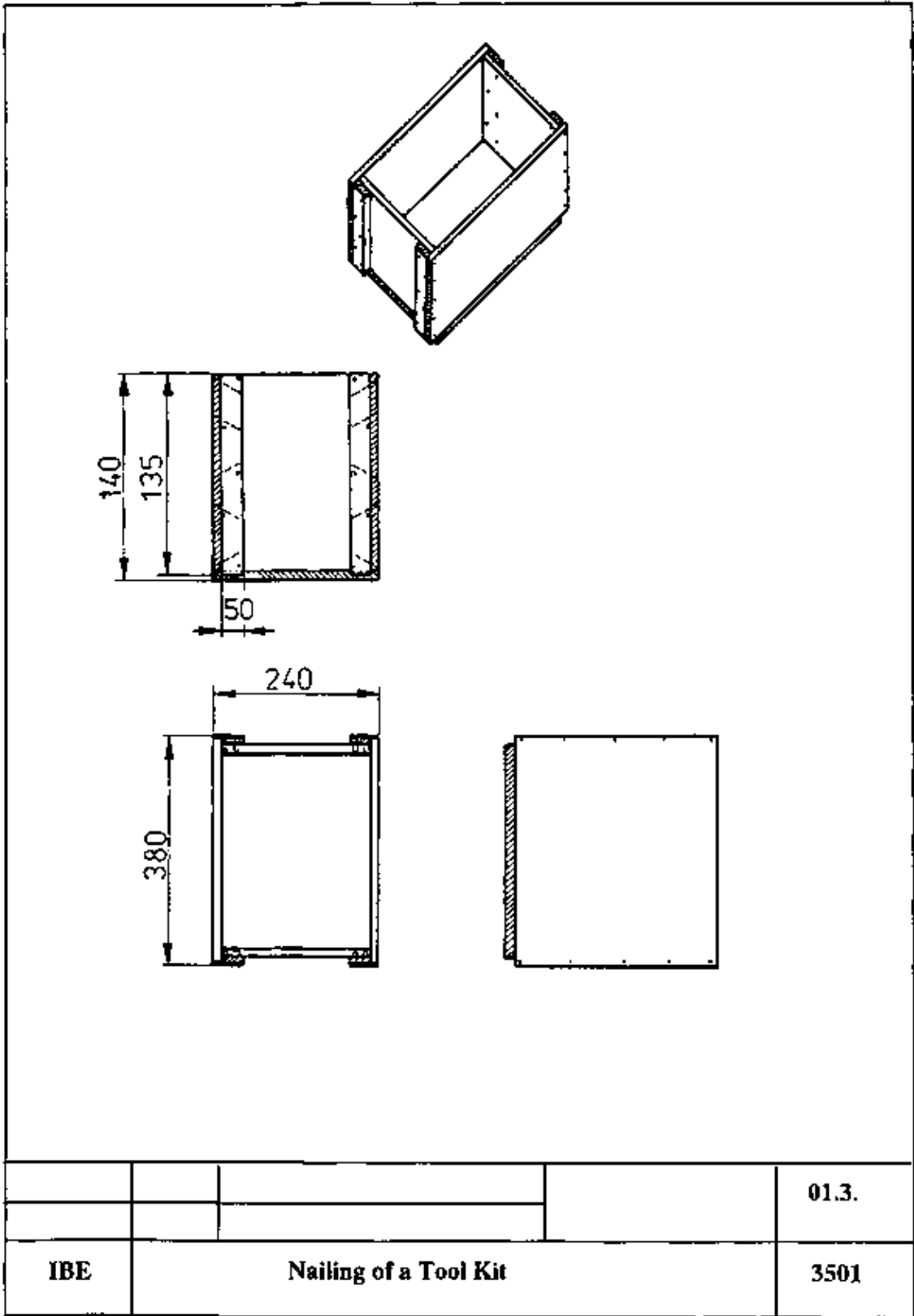

Nailing of a Tool Kit

### Instruction Example 01.4. Nailing of a Wall Panel

In this instruction example, the covered nailing is practised (assembly work).

#### Material

boards

planed, chamfered, groove and tongue shaped, with the following dimensions:

thickness: 18 mm

width without tongue: 80 mm

length: 2600 mm

(for two running metres wall panel: 25 off. The substructure 25 mm thick is evenly fastened to the wall to be panelled),

countersunk-head nails 40 mm long

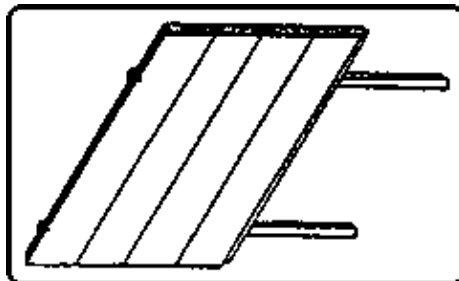

### Tools:

hammer, nail punch, pincers

### Measuring and testing means

straightedge, level, plumb line, vernier caliper

### Auxiliary means:

spacing strip 15 mm thick, abt. 500 mm long, pencil

### Required previous knowledge

reading of the drawing, measuring and scribing, testing

### Sequence of operations

1. Prepare the workplace, sort the boards and make them available, check the evenness of the sub-structure according to height and width
2. Determine the reference line for the first board on the left-hand side, the right-hand rear edge and mark it on the sub-structure with a pencil
3. Put the spacing strip onto the floor and place the first board on it (groove towards the left-hand side, tongue towards the right-hand side)
4. Mark the nailing points on the first board at the left-hand edge with a pencil, nail and drive in the nails with the punch
5. Nailing of the tongue
6. Placing and nailing of the next and all following boards

### Comments

- Check the completeness of the tools, auxiliary means and materials.
- Check the left-hand side with the level for evenness, apply the first board, mark the right-hand edge, check the vertical position by means of the plumb line, if necessary, correct, then mark on the sub-structure!
- The spacing strip ensures the ground clearance of the cross-cut surface of the boards.
- Fix the nailing points in accordance with the sub-structure. Drive in the nails straightly and sink them with the prick punch!
- Drive in the nails at an angle; as for the last centimeter: drive in the nails with the nail punch!
- Put the next board onto the spacing strip, joint it with the first one by slight blows with the hammer against the tongue (use a sectional shim block of wood). Nailing as under 5.! Proceed in the same way with all

the other boards!

7. Final check

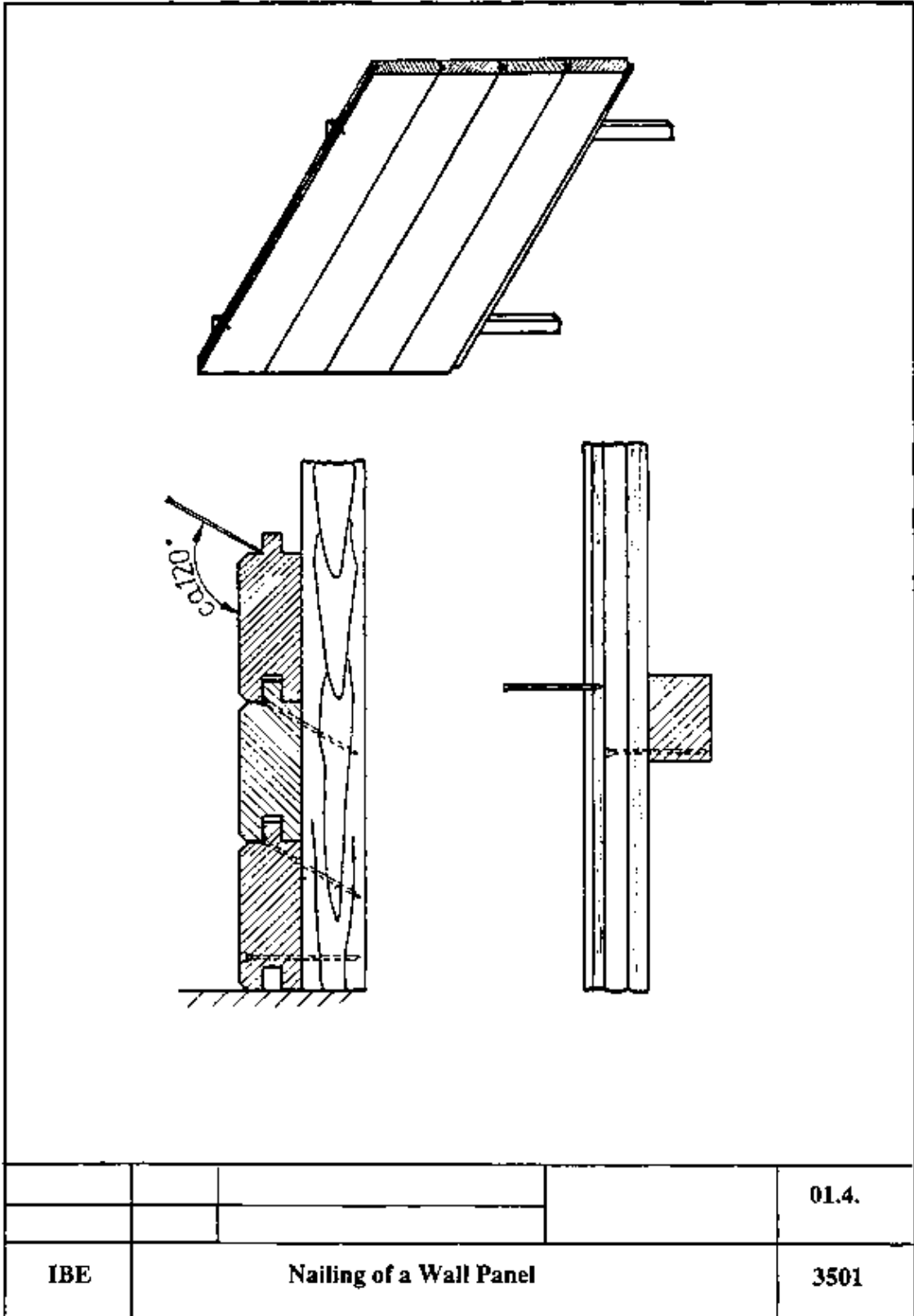

Nailing of a Wall Panel

## Instruction Example 01.5. Screwing of a Carrying Handle on a Tool Kit

In this instruction example, the joining of two boards by means of wood screws is practised.

### Material

- tool kit from instruction example No. 3
- finished carrying handle, board thickness: 20 mm
- 8 pcs. countersunk-head wood screw 3 x 30 mm

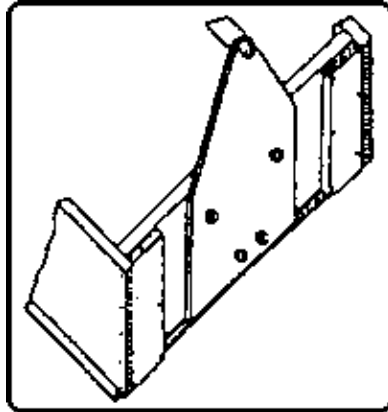

### Tools

screw driver 6 mm, wood drill 2 mm and 3 mm, bit brace with rose bit

### Measuring and testing means

back square, folding rule, vernier caliper

### Auxiliary means

joiner's bench, screw clamp, pencil

### Required previous knowledge

reading of the drawing, measuring and scribing, drilling

### Sequence of operations

1. Prepare the workplace, make the working materials available
2. Apply the handle holder according to the drawing and scribe it, determine the screwing points and mark them
3. Bore the handle holder 12 mm deep with the drill 3 mm dia. and ream it, fasten it with the screw clamp to the box according to the scribed line and go on boring and the predrilled holes with the drill
4. Screw in the countersunk-head screw with the screw driver
5. Screw on the second side of the handle holder (see operation 2. to 4.)

### Comments

Check the completeness of tools and materials

The handle holder is situated centrally to the box. The screwing points shall enclose a surface as large as possible, shall be staggered with the grain and have a distance to the edge of about 20 mm!

Fasten the screw clamp so that at least three holes can be drilled without hindrance. Observe the boring depth!

The blade of the screw driver must completely fill the slot in the screws so that it is possible to drive in the screws without damaging the slot and the wood edge!



6. Final check

- When visually checking, take heed of the following:
- the screw heads be must flush with the wood surface
  - all screws must be firmly screwed in
  - bores and screws must not be through, i.e. they must not be visible on the opposite side!

		<b>01.5.</b>
<b>IBE</b>	<b>Screwing of a Carrying Handle to a Tool Kit</b>	<b>3501</b>

Screwing of a Carrying Handle to a Tool Kit

## Instruction Example 01.6. Screwing on of a Screw-on Brace

In this instruction example, the fastening of a door hinge to a board leaf by means of countersunk-head wood screws and round-head bolts is practised.

### Material

- 1 plank door leaf
- 2 screw-on braces with screw holes 6.4 mm dia. and a punched hole for each screw hole of 8.4 mm dia.
- 6 off round-headed wood screws dia. 6 x 50 mm
- 2 off round-head bolts with square neck M 8 x 60 mm with washers and nuts

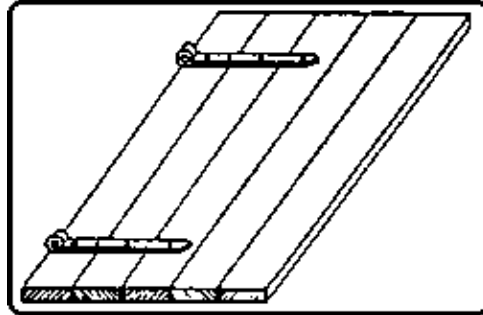

### Tools

screw driver 12 mm, wood drills 4; 6; 8 mm, screw wrench 13 mm

### Auxiliary means

joiner's bench, support, pencil

### Required previous knowledge

reading of the drawing, measuring and scribing, drilling

### Sequence of operations

1. Prepare the workplace, make the working materials available
2. Put on the braces to be screwed on, align and mark the screw bores with a pencil
3. Remove the screw-on braces, bore the screw holes
4. Put on the screw-on brace, insert the round-head bolts and fasten them with washers and nuts, drive in the wood screws with the screw driver
5. Final check

### Comments

- Check the completeness of the required tools and materials, put the door leaf onto the joiner's bench and support!
- The screw-on braces are centrally aligned above the crosspieces which hold the board cover and are screwed on. The required projecting length of the idler is to be observed/Check the proper position of the screwed on braces with a large back square!
- Drill through the 1st hole after the idler with a drill 8 mm, further holes are pre-drilled with a drill 6 mm, 20 mm deep, then bore 20 mm deeper with a drill 4 mm!
- Tighten the nuts with a screw wrench. The washer shall be pressed 1 mm into the wood. Firmly tighten the wood screws but do not overturn them!
- The long braces fit tightly to the wood, all screws are tightened, not overturned and not sheared off, bores for the wood screws are not visible on the inside of the door!

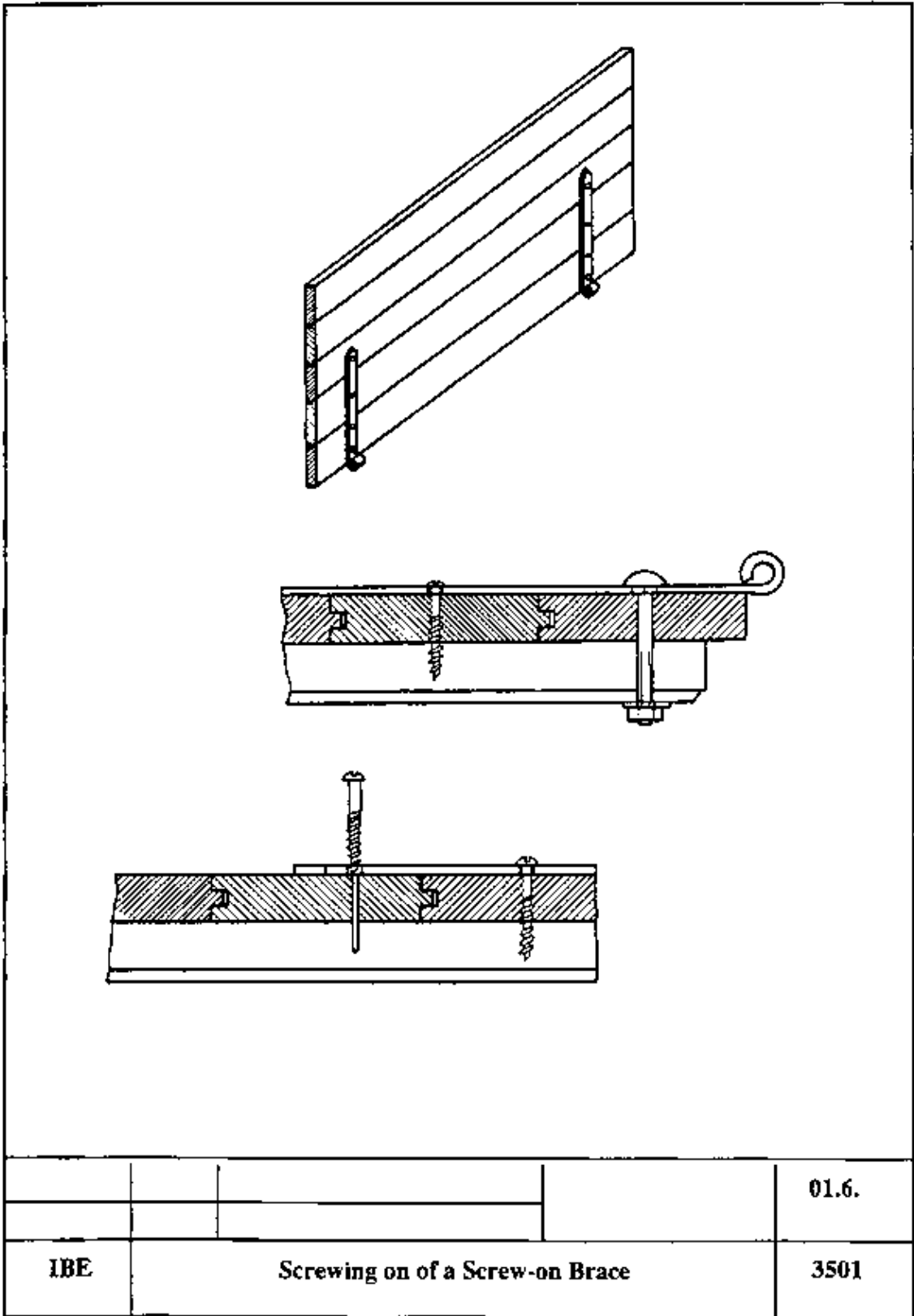

Screwing on of a Screw-on Brace



**Nailing and Screwing – Course: Making of wood joints. Trainees'  
handbook of lessons**



# Table of Contents

<b><u>Nailing and Screwing – Course: Making of wood joints. Trainees' handbook of lessons</u></b> .....	<b>1</b>
<u>1. Purpose and Application of Nailing and Screwing</u> .....	1
<u>2. Tools and Fasteners/Joining Elements for Nailing and Screwing</u> .....	1
<u>3. Nailed and Screwed Joints</u> .....	7
<u>4. Nailing and Screwing Techniques</u> .....	9





# **Nailing and Screwing – Course: Making of wood joints. Trainees' handbook of lessons**

**Institut für berufliche Entwicklung e.V.  
Berlin**

Original title:  
Arbeitsmaterial für den Lernenden  
"Nageln und Schrauben"

Author: Harald Stelzer

First edition © IBE

Institut für berufliche Entwicklung e.V.  
Parkstraße 23  
13187 Berlin

Order No.: 93–35–3501/2

## **1. Purpose and Application of Nailing and Screwing**

Nails and screws are slim metallic fasteners (joining elements) which are driven in and/or screwed in, in order to join two or more relatively thin workpieces or prefabricated parts.

Nailed and screwed joints can be quickly made with simple means and without major constructive expenditure, under erection conditions on the site as well.

Screws are primarily used as joining elements between metal and wood, e.g. the fastening of any kind of mountings on wooden piece parts and furniture. They can be easily loosened – thus making an exchange of the structural members possible. Nails are often used as fasteners/joining elements for several workpieces or prefabricated parts wherever a quick joining of piece parts is possible.

By driving in the nail with a hammer, compressions may occur on the material surface which is not always desired.

Nails and screws can fulfill different tasks:

- as a self-supporting (holding!) joint,
- as a securing (supporting) joint together with other joints and fasteners, e.g. glue.

Nails and screws join the workpieces in one point only. To make an areal joint, it is necessary to drive in and/or screw in several nails or screws at a distance to each other as large as possible.

## **2. Tools and Fasteners/Joining Elements for Nailing and Screwing**

The tool used for driving in the nails, is the joiner's hammer. The hammer consists of a steel hammer head and a handle made of wood. Corresponding to the required effect of impact, they are produced in different weights. In the joiner's shop, hammers with 150 g, 300 g and 600 g weight are generally used. Small nails are driven in with a light hammer, medium-size nails with a medium-weight hammer and large nails with a heavy hammer.

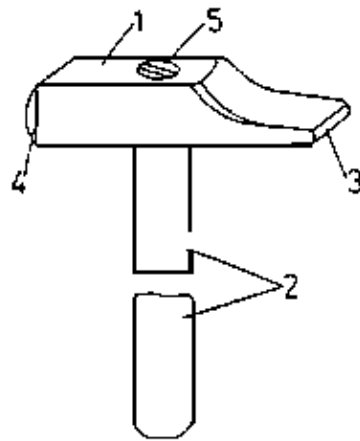

**Figure 1** Joiner's hammer

*1 hammer head, 2 handle, 3 paw, 4 face, 5 eye*

Why are hammers of different weights required?

---

The hammer handle must be tightly fitted into the eye of the hammer head and flush on top. It must be diagonally wedged!

For sinking the nail heads, a nail punch is used. Punches are made of steel. They have a cylindrical form, run conically towards below and end with a plane, round surface of 2 to 5 mm dia. With this surface, they are applied to the nail head and held with the left hand in the direction of the nail. By slight blows with the hammer on the head of the nail punch, the nail head is driven into the wood.



**Figure 2** Nail punch

When sinking, there is a risk of bouncing, therefore the nail punch has to be held fast and safely, it must not slip off the nail head!

What are nail punches used for?

---

The tool used for driving in or loosen screws, is the screw driver. It consists of a steel blade, having the form of a wedge at the end and being slightly hollow–chamfered, which is joined with a handle. The screw drivers are made in different sizes. The size to be used depends on the screws to be driven in. The end of the screw driver must correspond to the dimension of the screw slot so that it is possible to drive in or out the screw without damaging the slot of the countersunk–head screw or the wood edge.

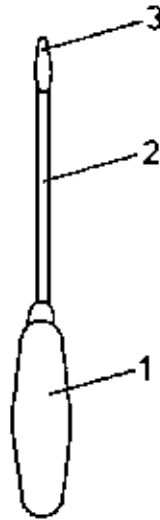

**Figure 3** Screw driver

*1 handle, 2 blade, 3 driving edge*

If too much force is applied, there is a risk of slipping off and hence a risk of injury!

Depending on the application, nails and screws are manufactured in different kinds, forms and sizes. The following kinds are distinguished:

### **Nails**

#### *Unhardened steel nails*

They are called wire or French nails. These nails are primarily used in joineries.

#### *Hardened steel nails*

Steel nails, due to their high strength, penetrate hard materials as well, e.g. brickwork, without being bent.

#### *Hot-dip galvanized nails*

Galvanized nails are wire nails with a zinc coating. By this, a good protection of the surface against corrosion is achieved. They are used for structural parts which are exposed to the influence of the weather.

### **Screws**

Screws are made of steel or anti-corrosive alloys. Wood screws are also made of brass or aluminium. These screws are mainly required for the fastening of mountings of the corresponding material.

Why are different kinds of nails and screws necessary?

---

As to form, one differentiates between the following kinds:

### **Nails**

#### *Flat head nails*

Flat head nails are used when thin sheet materials, e.g. plywood, hard boards, are fastened to solid wood (rear walls for furniture). Flat head nails are not suited for being sunk.

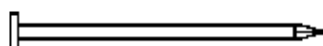

**Figure 4** Flat head nail

*Counter sunk–head nails*

Countersunk–head nails are used for joining wood pieces. They have the form which is in common use in a joinery.

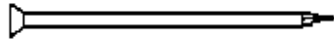

**Figure 5** Countersunk–head nail

*Upset–head nails*

Upset–head nails are driven in when the nail head shall not be visible. When fastening thin sheet materials, there is a risk that the head penetrates the sheet material and does not hold it fast.

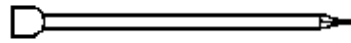

**Figure 6** Upset–head nail

Apart from these nail forms, a variety of special nail forms for the most diverse applications are used. Among these are nails without heads, as well as ornamental nails and pins.

**Screws**

*Counter sunk–head wood screw*

Countersunk–head wood screws can be driven into the wood so that they are flush with the surface. They are the screw form which is generally used in a joinery.

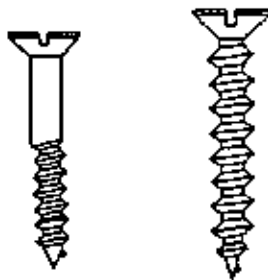

**Figure 7** Countersunk–head wood screw

*Oval head countersunk wood screw*

Oval head countersunk wood screws are used for the fastening of mountings.

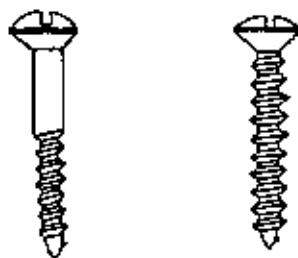

**Figure 8** Oval head countersunk wood screw

*Round head wood screw*

Round head wood screws are not suited for being sunk. They are used for the fastening of mountings and as ornamental screws.

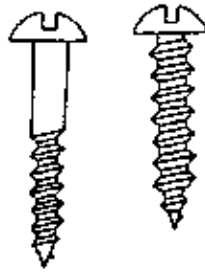

**Figure 9** Round head wood screw

*Hexagon head wood screw*

Hexagon head wood screws are used in the structural timber construction, e.g. supporting structures, roof coverings. They are screwed in and/or screwed out with the screw wrench.

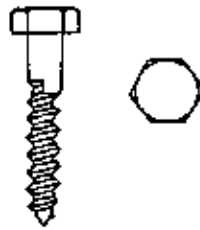

**Figure 10** Hexagon head wood screw

*Cup square bolt*

Cup square bolts are used for fastening the screw-on braces to the door leaf. The square situated under the head fits in a square hole correspondingly punched in the mounting or wood. This screw is fastened with a washer and a hexagonal nut. The cup square bolt cannot be loosened on the mounting side. For the fastening of chipboards, countersunk-head screws or round head screws with the thread extending over the entire length of the cylindrical shank are used.

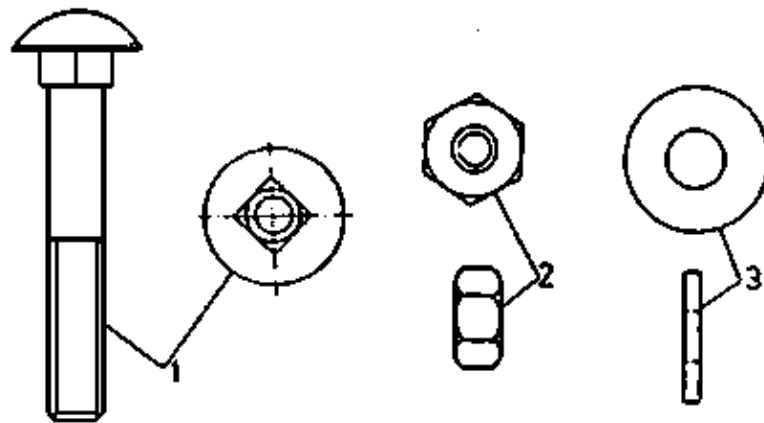

**Figure 11** Cup square bolt

*1 head with square, 2 nut, 3 washer*

**Table 1: Nail sizes**

Flat head nails		Countersunk-head nails		Upset-head nails	
Length	Diameter	Length	Diameter	Length	Diameter
mm	mm	mm	mm	mm	mm

6	0.6	20	1.4	8	0.8
8	0.6	25	1.6	10	0.8
10	0.8	30	1.8	12	1
12	1	35	1.8	14	1
14	1	40	2	16	1
16	1	45	2.2	18	1.2
20	1.2	50	2.2	20	1.4
25	1.4	55	2.5	25	1.4
30	1.6	60	2.5	30	1.6
		65	2.8	35	2
		70	3.1	40	2
		80	3.1	45	2
		90	3.4	50	2
		100	3.8	60	2.5
		110	4.2	70	3.1
		120	4.2	80	3.1
		130	4.6	100	3.8
		140	4.6		
		160	5.5		
		180	6		
		200	6		

Table 2: Screw sizes

<b>Countersunk-head wood screw</b>							
<b>Oval head countersunk screw</b>			<b>Hexagon head wood screw</b>			<b>Cup square bolt</b>	
<b>Round head wood screw</b>							
<b>Length</b>	<b>Diameter</b>		<b>Length</b>	<b>Diameter</b>		<b>Length</b>	<b>Diameter</b>
	<b>Shank</b>	<b>Thread core</b>		<b>Shank</b>	<b>Head</b>		<b>Thread</b>
<b>mm</b>	<b>mm</b>	<b>mm</b>	<b>mm</b>	<b>mm</b>	<b>mm</b>	<b>mm</b>	<b>mm</b>
7	1.5 – 3	1 – 2.1	30	6 – 10	10 – 17	25	M5
10	1.5 – 3	1 – 2.1	35	6 – 10	10 – 17	30	M5 – M6
15	1.5 – 4	1 – 2.8	40	6 – 10	10 – 17	35	M5 – M8
20	2 – 6	1.4 – 4.2	45	6 – 12	10 – 19	40	M5 – M10
25	2.5 – 6	1.7 – 4.2	50	6 – 12	10 – 19	45	M5 – M12

30	3 – 6	2.1 – 4.2	60	6 – 10	10 – 24	50	M5 – M12
35	3 – 6	2.1 – 4.2	70	6 – 16	14 – 24	55	M5 – M16
40	4 – 8	2.8 – 5.6	80	8 – 20	14 – 30	60	M5 – M16
45	4 – 6	2.8 – 4.2	90	8 – 20	14 – 30	65	M6 – M16
50	4 – 8	2.8 – 5.6	100	8 – 20	14 – 30	70	M5 – M16
60	5 – 8	3.5 – 5.6	110	8 – 12	14 – 19	75	M6 – M16
70	6 – 8	4.2 – 5.6	120	8 – 20	14 – 30	80	M6 – M16
80	6 – 8	4.2 – 5.6	130	8 – 12	14 – 19	90	M6 – M16
			140	10 – 20	17 – 30	100	M8 – M16
			150	12 – 20	19 – 30		
			160	16 – 20	24 – 30		
			180	16 – 20	24 – 30		
			200	16 – 20	24 – 30		

Nails and screws are denominated as to

- form,
- required material, e.g. bare, galvanized, brass, etc.,
- required shank diameter, and
- length.

**Example:**

Countersunk-head screw, brass, 3 x 30  
(shank diameter = 3 mm; length = 30 mm)

### 3. Nailed and Screwed Joints

#### Nailed joints

When in the manufacture of supports and girders more than two boards shall be joined by means of nails, then these joints have to be made as two-shear or multi-shear nailed joints. These joints have to be statically calculated. Correspondingly, the kind, size and number of nails to be used are specified. Depending on the existing joint surface and in consideration of the minimum distances, nailing patterns (nailing points) are fixed. Nailing is done by means of patterns.

Single-shear nailed joints are produced when two parts are nailed together. In doing so, the nails are normally tensile-stressed in their longitudinal axis. This ability of the nail to absorb tensile forces is called "extraction resistance". Among other factors, the extraction resistance is determined by the strength of the wood, the nail length and the shank dia. of the nail. When driving in the nail, the wedge-type point punches through and destroys a part of the fibres of the wood. The other fibres are pushed aside and compressed and clamp the nail shank. The strength of a nailed joint increases proportionally to the number of nails if the

minimum distances between the nails and the distances to the edge are observed.

The minimum distances between the nails are calculated proceeding from the diameter of the nail shank (d). When nailing in a row with the grain and side by side, the distances are not less than 10 d. The distance from the edge in grain direction must be at least 5 d, the distance from the board ends at least 10 d. The following rule applies: "Nail as many nails as necessary, not as many as possible!"

Frame corners are nailed with 2 to 4 nails which shall have a distance from each other as large as possible.

Nailings in a row (rear walls of furniture, glass strips) are made in dependence on the nail size at a distance of 100 to 200 mm.

Why are minimum distances between the nails and distances from the edge to be adhered to?

---

As far as no constructional requirements are in contrast with it, the following basic rules are to be followed:

- Nailing is performed from the soft into the hard wood.
- Nailing is performed from the thin into the thick wood.
- When nailing in hard wood, pre-drilling has to be carried out. The diameter of the drill is 0.8 d of the nail.
- When nailing in cross-cut wood, the nails have to be driven in at an angle so that they penetrate several annual rings, if possible. Nails which are vertically driven into cross-cut wood have hardly any extraction resistance!
- When nailing through round wood, nailing has to be done along the tangent line!
- When nailing at the ends of a board, the nail points are upset so as to reduce their effect of splitting.

### **Screwed joints**

Multi-shear screwed joints (pressure- or tensile-stressed) are required in the wood construction work (supporting frameworks such as roof frameworks, bridges, scaffoldings). They are executed with through screw bolts. The screws are fastened with washers and nuts.

Wood screws are used as joining elements and fasteners for wood parts or for the fitting of mountings. The screws are tensile-stressed as to their longitudinal axis. In case of a proper mounting, wood screws have a very large extraction resistance. They must not be driven in with a hammer!

Screw holes are to be pre-drilled!

About 60 % of the length of the wood screw is provided with a thread which draws in or loosens the screw at a rotary motion and light pressure.

### **Holes**

For small screws can be pre-cut with a steel square having the respective size; for larger screws, the holes must be pre-drilled. Doing so, the bore-hole with the diameter of the screw shank or slightly less has to be executed some 40 % of the screw length deep. As for large screws, it can be necessary to pre-drill additionally some 40 % of the screw length with the diameter of the thread core. Cup square bolts are pre-drilled with their shank diameter + 0.4 mm.

Pre-drilling of the screw holes saves force to be applied when screwing in the screws and prevents the screw driver from slipping off if too much pressure is applied!



## 4. Nailing and Screwing Techniques

### Nailing techniques

Nailing is effected on a firm, not springy support. The nail, when being driven in, is held and guided with the left hand at the shank until it sticks sufficiently deep and tight in the wood. The hammer is taken with the right hand at the end of the handle; hammering is done from the wrist. The hammer must be guided slackily and without clenching. When driving in the nail, the direction of the blows must be the longitudinal axis of the nail. Nailing is done with the hammer face.

#### *Nailing of a lath grid*

This simple nailing technique is applied when wood joints of laths and crosspieces (joists) shall be made by means of nails. With determining the nailing points, the required distances to the edge have to be adhered to.

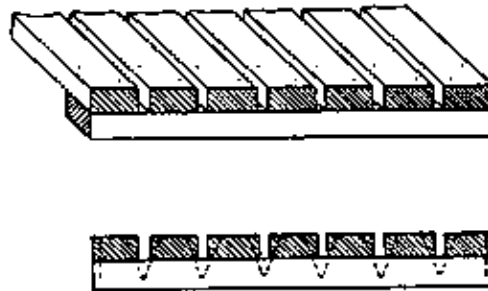

**Figure 12** Nailing of a lath grid

The nails to be driven into the first and the last lath must be upset so as to avoid a splitting of the crosspieces. For upsetting, the nail is put with its head on a firm support and held fast. By slight blows with the hammer onto the nail point, it is upset through which the splitting effect of the nail is reduced.

Each lath is nailed to each crosspiece with two nails. To increase the durability of each joint, the rear nail is nailed with an inclination towards the back and the other nail with an inclination towards the front. The inclined position of the nails shall be about  $15^\circ$  deviating from the vertical. The nail length is at least double as long as the thinner board but shorter than both parts.

#### *Nailing of a halved frame corner joint*

This nailing technique is used for subordinated structural parts (makeshift nailing) only.

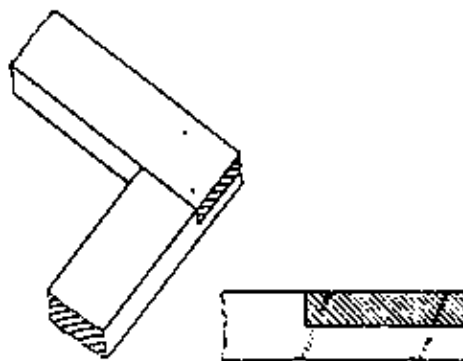

**Figure 13** Nailing of a halved frame corner joint with presentation of the clinched nail

This nailing technique with overlong nails implies a risk of injury due to bursted out wood fibres and projecting nail points!

The nails are driven in with the grain as to the lower surface with an inclination of  $15^\circ$  deviating from the vertical. The point of the nail is deflected through slight blows of the hammer when it impacts on the steel plate and then penetrates the wood again. The workpiece has to be firmly pressed onto the steel plate (screw clamp). The nail length is about  $10 \text{ mm} +$  the overall wood thickness.

### *Nailing of a tool kit*

In addition to the simple nailing, the nailing with overlong nails, as well as folding back and hammering back of the overlength is important.

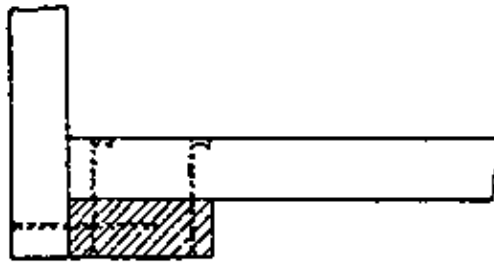
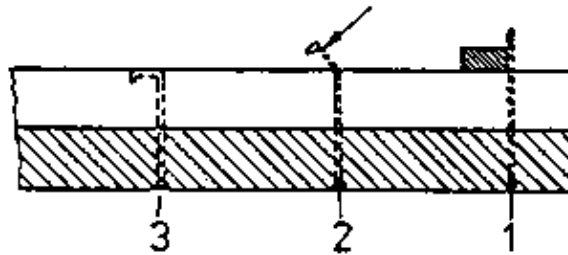

**Figure 14** Nailing of a tool kit

The nails are driven into the laths and boards vertically and flush with the surface. Base blocks of wood are to be used so that the nails do not penetrate the joiner's bench.

The workpiece must not be springy; otherwise there is a risk of slipping off when hammering and so there is a risk of injury!

Nailing is done in the form of a triangle. When folding back the nails, the steel bar must be firmly pressed against the nail shank. It has to be seen to it that a firm support is used so that the nails cannot be hammered out and that the nail head remains flush with the wood surface. Folding back of the nails is accomplished in the grain direction of the wood. Hammering is done with the hammer face, on principle.



**Figure 15** Folding back of the overlong nail

*1 nail driven in, 2 nail folded back at the steel bar, 3 nail point hammered back into the wood*

The distances of the nails to the edge are absolutely to be observed!

The nail length is at least 15 mm + the overall wood thickness.

### *Nailing of a wall panel*

This nailing technique can be applied if large areas of boards with shaped grooves and tongues shall be produced on a sub-structure of wood. The advantage of this is that the nails are invisible after completion.

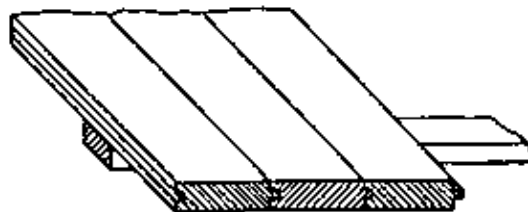

**Figure 16** Nailing of a wall panel

The first board on the left-hand side is begun with. After an exact aligning, the board is nailed from the front onto the sub-structure close to the left-hand narrow surface (groove side). On the right-hand side, this board and all following ones are not nailed onto the sub-structure from the front but at the narrow surface through the shoulder line of the tongue.

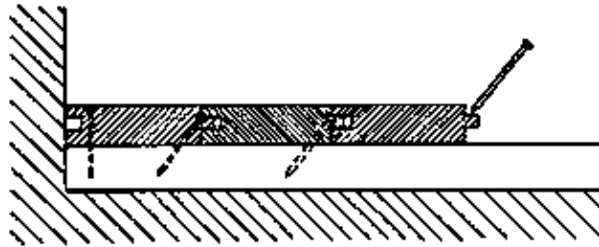

**Figure 17** Covered nailing

The nails are driven in at an angle of  $120^\circ$  to  $135^\circ$ . To avoid damages of the wood edges and the tongue, the last blows are made by using the nail punch. The nail head is sunk. The nail length has to be chosen in dependence on the construction.

### **Screwing technique**

When several screws shall be driven into a workpiece, then the individual parts have to be secured against shirting.

Pre-drilling and/or pre-cutting is necessary in any case!

To maintain the screwing-in and/or drawing-out resistance, the screw holes must not be pre-drilled too large and not too deep. The end of the insert of the screw driver shall have the width of the screw head diameter. It must fit exactly into the screw slot. When driving in the screw, the screw head and the end of the insert of the screw driver have to be guided with the left hand.

Do never drive in screws with a hammer!

Bore holes for cup square bolts are to be pre-drilled through all parts to be joined with  $d + 0.4$  mm. Cup square bolts are driven in by slight blows with a hammer and fastened with washers and nuts. The length depends on the thickness of all parts to be joined, adding about + 10 mm.

### *Screwing of a carrying handle to a tool kit by means of counter sunk-head screws*

This screwing technique can be used for fastening a board onto another. The screwing points shall give a regular picture but shall not lie in the same annual ring.

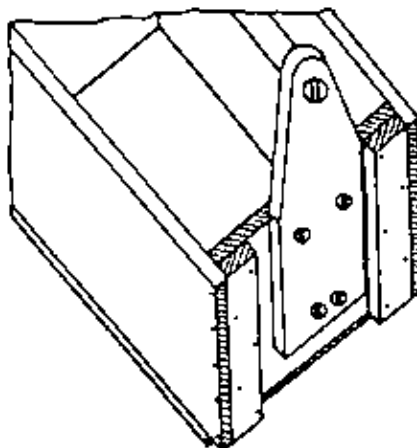

**Figure 18** Screwing of a carrying handle to a tool kit

After scribing and marking the screwing points at the handle holder, the holes are pre-drilled 12 mm deep with the shank diameter of the countersunk-head screws (3 mm). The bore holes at the front are reamed with the rose bit. After fastening the handle holders to the tool kit by means of screw clamps, the screw holes are concentrically pre-drilled deeper by another 12 mm with the drill dia. 2 mm.

The countersunk-head screws are put into the bore-holes by applying pressure with the thumb (do not use a hammer!) and screwed clock-wise into the wood with a suitable screw driver by applying light pressure. Doing so, the end of the blade of the screw driver and the head of the countersunk-head screw are to be guided

with the left hand. Thereby it is avoided that the screw driver slips off the slot of the screw head.

By the screw driver slipping off, the wood surface may be damaged and accidents (injuries of the left hand) may occur. Screw driver handles must be clean, tightly fitting and non-slipping!

Why must wood screws not be driven in with a hammer?

---

#### *Screwing on of a screw-on brace*

By applying this screwing technique, metal mountings can be fastened to structural parts of wood.

The selection of the respective screw shank diameter depends on the prepared holes at the metal mountings. The shank diameter of the screw shall be about 0.4 mm smaller than the hole diameter in the mounting.

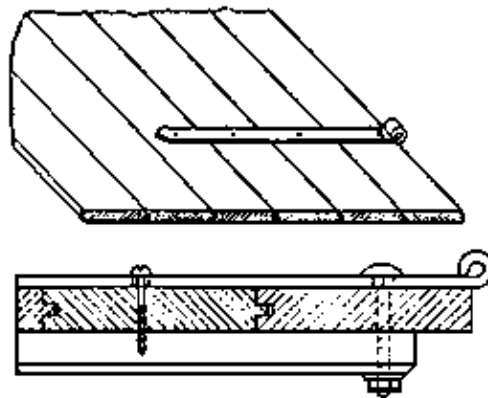

**Figure 19** Screwing on of a screw-on brace

The screw length is chosen in dependence on the thickness of all parts to be joined. The wood screws are shorter than the parts to be joined. The cup square bolts are abt. 10 mm longer than the thickness of all parts to be joined so that the washer and the lock nut can be screwed on.

After scribing, the bore holes for the wood screws are vertically pre-drilled about  $0.4 \times$  screw length deep with the shank diameter of the chosen wood screws and after that, if hard wood or large screws are used, the same depth is drilled once again with the diameter of the thread core. The hole for the cup square bolt is drilled with the diameter  $0.4 + d$  of the screw through all wood parts to be joined. Here, splitting of the wood fibres has to be avoided when the drill comes out of the wood.

After scribing the hole, take off the mounting and do not guide the drill through the hole in the mounting!

The cup square bolt is driven through the hole in the mounting and the bore hole by slight blows with the hammer and fastened from below with a washer and a nut. The square neck must tightly stick in the punched hole of the mounting.

The wood screws are screwed in with the appropriate screw driver. In doing so, the screw head and the end of the screw driver are guided with the left hand and secured against slipping.

**Planing out – Course: Manual woodworking techniques. Instruction examples for practical vocational training**



# Table of Contents

<b><u>Planing out – Course: Manual woodworking techniques. Instruction examples for practical vocational training</u></b> .....	<b>1</b>
<u>Preliminary Remarks</u> .....	1
<u>Instruction Example 4.1.: Board</u> .....	1
<u>Instruction Example 4.2.: Strip and Panel</u> .....	4
<u>Instruction Example 4.3.: Shaped Strip</u> .....	7





# Planing out – Course: Manual woodworking techniques. Instruction examples for practical vocational training

Institut für berufliche Entwicklung e.V.  
Berlin

Original title:

Lehrbeispiele für die berufspraktische Ausbildung  
"Aushobeln"

Author: Rolf Jakoby

First edition © IBE

Institut für berufliche Entwicklung e.V.  
Parkstraße 23  
13187 Berlin

Order No.: 93–33–3304/2

## Preliminary Remarks

The present booklet contains 3 selected instruction examples by means of which the trainee is able to acquire fundamental knowledge and skills in the working technique of planing. This work also includes sharpening of the plane irons if the tools' condition should make that necessary.

For a better preparation and execution of works, the required materials, tools, measuring and testing means and auxiliary accessories are specified for each instruction example. Furthermore, the previous knowledge is given that is required to work the workpieces. Knowledge already acquired for sharpening of tools from the training courses "Ripping and Mortising" or "Splitting and Carving" should be incorporated into the lessons as recapitulation.

The three instruction examples can be accomplished on various workpieces having different dimensions, but also consecutively on one workpiece.

The sequence of operations specified for each instruction example includes working steps leading to the acquisition of the working technique and the manufacture of the relevant workpiece. Technical particularities and the achievement of quality features are specifically mentioned.

A working drawing is attached to each instruction example showing the required shape and the dimensions of the workpiece. Dimensions not given have to be determined by the instructor according to further working steps intended. These dimensions can be selected so as to permit the use of the manufactured workpieces for the production of furniture such as benches, tables and shelves or for structural elements and facing parts.

## Instruction Example 4.1.: Board

Planing of wide faces is practised on saw-rough, edged boards.

### Material

Saw-rough, edged boards:

Width: min. 100 mm  
Length: min. 800 mm  
Thickness: min. 30 mm

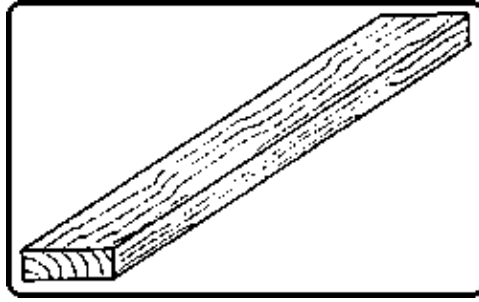

**Tools**

Jack plane, finish plane, double plane, trying plane, marking gauge, metal hammer 250 to 500 g, screw driver (large-sized)

**Measuring and testing means**

Folding rule or measuring tape, straightedge, 2 parallel strips

**Auxiliary accessories**

Carpenter's bench, tool grinder, whet-stone and stoning fluid (oil or water)

**Required previous knowledge**

Reading of drawings, measuring, scribing, testing

**Explanations to the working drawing**

x – optional size

? – equal to or greater than

**Sequence of operation**

**Comments**

1. Determine the direction of grains in work-piece.

2. Clamp workpiece between clamp irons of carpenter's bench according to working direction and the direction of grains.

When planing "with the grain", direction of grains is ahead and upwards; keep clamp irons under the surface to be planed.

3. Adjust finish plane to exact shaving thickness.

4. "Smooth" wood surface with long pushes of the plane over its entire surface.

Work surface always with its entire width within working steps; in the case of counter-direction of the grains, clamp workpiece reversely.

5. Prepare and adjust the double plane and the trying plane to flatten and smooth the wood surface.

6. Flatten and smooth the surface by the double plane and the trying plane.

First use the double plane and then the trying plane.

7. Check the surface for flatness by the straightedge and by alignment.

Lay straight batten in longitudinal and cross directions onto planed surface and compare; apply parallel strips. At the workpiece ends and check by sighting, repeat the check in certain intervals.

8. Surface the unevenness by double plane and trying plane.

It is advisable to work in an oblique direction to the wood grains and to apply last pushes of plane in the direction of the grains.

9. Repeat the check for surface flatness.

10. Reclamp workpiece for scribing of the thickness.

Clamp workpiece with narrow face showing upwards between clamp irons or front chop of carpenter's bench.

11. Scribe required thickness at narrow faces starting from the worked wide face.

Use marking gauge with scriber.

12. Prepare and adjust the jack plane.

Only use jack plane, if great material thickness must be removed.

13. Plane material by jack plane, double plane and trying plane up to final thickness acc. to working steps Nos. 1 to 9.

14. Sharpen plane irons, if necessary.

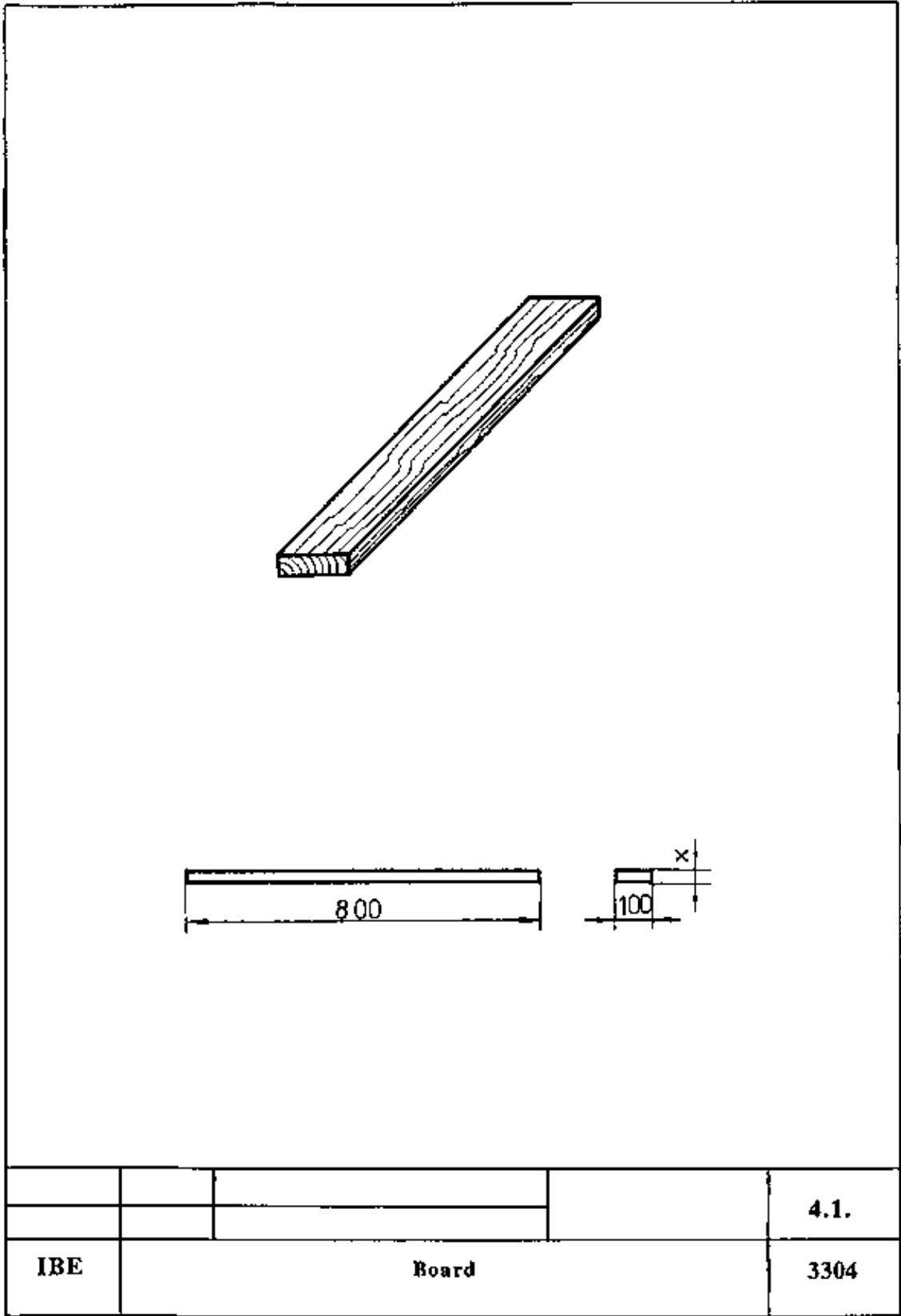

Board

**Instruction Example 4.2.: Strip and Panel**

Planing of narrow faces is practised on edged boards, slats or strips.

**Material**

Edged boards, slats or strips with at least one planed wide face:

Width: min. 60 mm

Length: min. 300 mm

Thickness: min. 10 mm

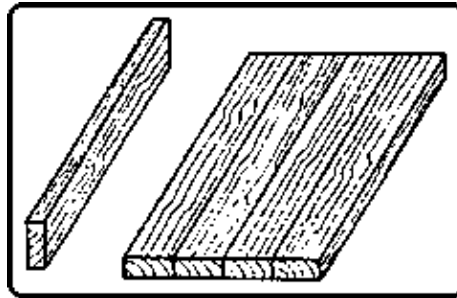

### Tools

Jack plane, finish plane, double plane, trying plane, metal hammer 250 to 500 g, screw driver (large-sized)

### Measuring and testing means

90° steel square, folding rule or measuring tape, straightedge

### Auxiliary accessories

Carpenter's bench, guide strip, workpiece stand (if possible, adjustable in height), tool grinder, whetstone and stoning fluid (oil or water), pencil

### Required previous knowledge

Reading of drawings, measuring, scribing, testing; types, construction and mode of action of planes, handling of planes, sharpening of plane irons

### Explanations to the working drawing

x – optional size

? – equal to or greater than

### Sequence of operations

(Working of individual workpieces which are not joined to form one surface (1))

1. Prepare carpenter's bench, prepare tools.
2. Clamp workpiece into carpenter's bench with longitudinal narrow face showing upwards.
3. Plane greater unevenness by jack plane and smooth plane.
4. Flatten and smooth narrow face by trying plane.
5. Check straightness of narrow face by straightedge.
6. Check squareness to planed wide face by steel square.
7. If necessary, rework and check until quality requirements are met.

### Comments

Check sharpness and adjustment of plane irons.

Take care of working direction and direction of grains in the workpiece; support long work-pieces at the side not clamped.

Use rectangular guide strip for trying plane.

A hardly noticeable light gap must be between narrow face and testing means.

8. Scribe required workpiece width.

Use rule, straightedge and pencil.

9. Work opposite narrow face acc. to working steps Nos. 2 to 7.

10. Clamp workpiece with an end-grained narrow face showing upwards.

11. Flatten and smooth the end-grained narrow face by double plane or trying plane.

Only use sharp plane irons; adjust a very fine thickness of shavings; effect pushes of plane only up to the centre of the narrow face; use trying plane for longer narrow faces only.

12. Check the narrow face acc. to working steps Nos. 5 and 6 and check squareness to longitudinal narrow faces.

13. Work opposite narrow face acc. to working steps Nos. 10 to 12.

(Fitting of similar workpieces to subsequently connect them to a greater surface (2))

1. Put workpieces not yet worked (boards) together in the order intended.

The following basic rule applies to putting together: connect heartwood with heartwood and sapwood with sapwood.

2. Mark connecting points (joints).

Narrow faces to be connected are marked with a triangle on the wide face.

3. Work the first narrow face of a joint acc. to working steps Nos. 2 to 7 for individual workpieces.

4. Work matching narrow face of the board acc. to working steps Nos. 2 to 4 for individual workpieces.

5. Check the fit of the joint by next applying the matching narrow face already worked.

Joint must be tight over its entire length (light gap not visible).

6. In case of untight joint, rework the narrow face.

7. Repeat the working steps Nos. 3 to 6 until all joints are worked.

8. Sharpen dull plane irons.

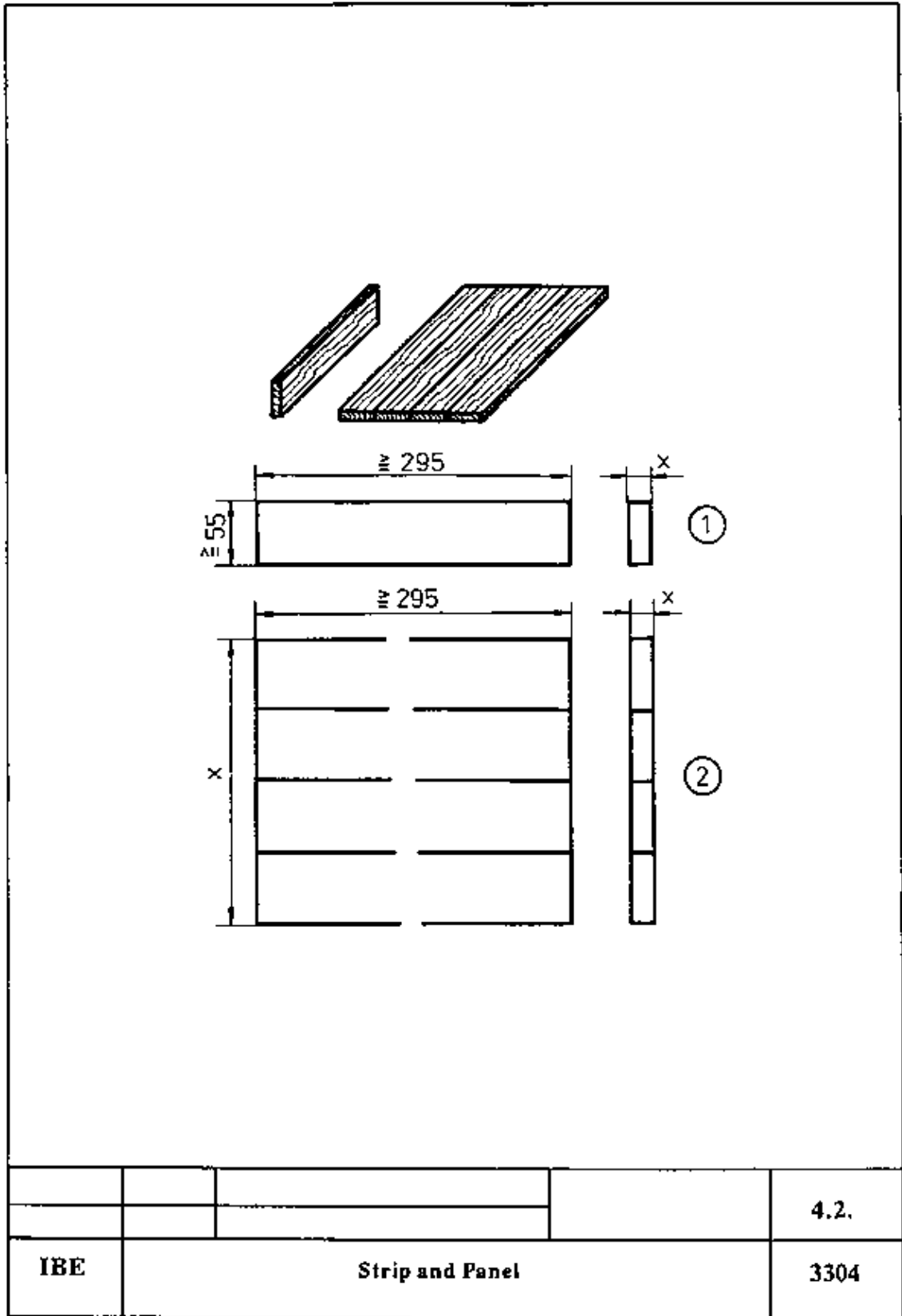

Strip and Panel

### Instruction Example 4.3.: Shaped Strip

Planing of profiles is practised on a planed board.

**Material**

Boards, planed:

Width: min. 55 mm

Length: min. 250 mm

Thickness: min. 20 mm

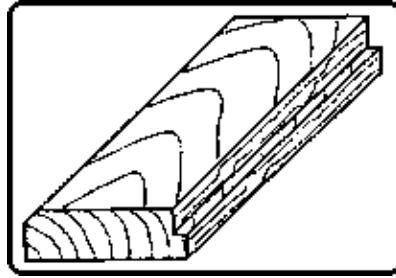

### Tools

Double plane, trying plane, rabbet plane, metal hammer, marking gauge, screw driver

### Measuring and testing means

Folding rule or measuring tape, straightedge (minimum length acc. to length of workpiece)

### Auxiliary accessories

Carpenter's bench, clamps, tool grinder, whet-stone and stoning fluid

### Required previous knowledge

Reading of drawings, measuring, scribing, testing; types, construction and mode of action of planes, handling of planes, sharpening of plane irons

### Explanations to the working drawings

? – equal to or greater than

#### Sequence of operations

1. Arrange workplace; check, adjust and prepare tools.
2. Scribe profile edges acc. to drawing.
3. Clamp workpiece in carpenter's bench with the edge to be bevelled showing upwards.
4. Plane chamfer up to edge markings by double plane and trying plane.
5. Check straightness of bevelled narrow face (chamfer) by straightedge.
6. Measure planed chamfer width by means of the rule.
7. Reclamp the workpiece, wide face showing upwards.
8. Apply straightedge to wide face and place against profile marking.
9. Secure accurate-to-size position of straightedge by clamps.

#### Comments

Mark dimensions onto the wide and narrow faces by means of the marking gauge.

Take care of constant distance between face of plane and edge markings.

Measure at the workpiece's beginning and end and repeat it in regular length distances.

Straightedge should slightly overlap the marking towards the face to be planed out.

Clamps should clamp together the straightedge, workpiece and carpenter's bench plate.



10. Plane out the material up to marked rabbet depth by means of rabbet plane.

Move rabbet plane in straight line along straightedge and always rectangularly to wide and narrow faces. Take care of direction of wood grains.

11. Loosen and remove the straightedge.

12. Reclamp workpiece in carpenter's bench with the narrow face to be provided with the rabbet profile showing upwards.

13. Re-plane rabbet up to marked rabbet width by means of the rabbet plane.

14. Check flatness and straightness of profile faces by alignment and by means of an applied straightedge.

15. Sharpen dull plane irons.

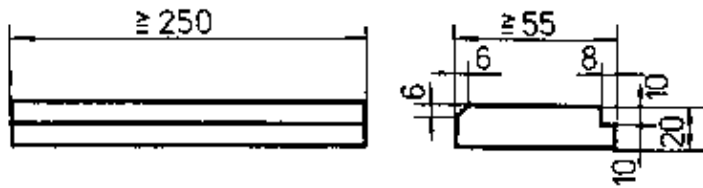
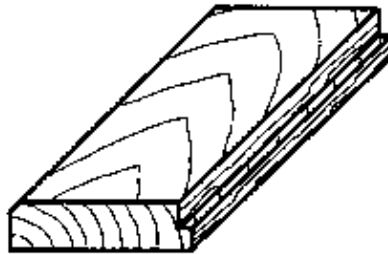

				4.3.
<b>IBE</b>	<b>Shaped Strip</b>			<b>3304</b>

Shaped Strip

**Planing out – Course: Manual woodworking techniques. Trainees'  
handbook of lessons**



# Table of Contents

<b><u>Planing out – Course: Manual woodworking techniques. Trainees' handbook of lessons</u></b> .....	<b>1</b>
1. <u>Purpose and Application of Planing</u> .....	1
2. <u>Construction and Mode of Action of the Planes. Types of Planes</u> .....	1
3. <u>Preparations for Planing</u> .....	5
4. <u>Planing of Wide Faces</u> .....	12
5. <u>Planing of Narrow Faces</u> .....	13
6. <u>Planing of End-grained Narrow Faces (Sectional Areas)</u> .....	14
7. <u>Planing of Profiles</u> .....	15



# Planing out – Course: Manual woodworking techniques. Trainees' handbook of lessons

Institut für berufliche Entwicklung e.V.  
Berlin

Original title:  
Arbeitsmaterial für den Lernenden  
"Aushobeln"

Author: Rolf Jakoby

First edition © IBE

Institut für berufliche Entwicklung e.V.  
Parkstraße 23  
13187 Berlin

Order No.: 93–35–3304/2

## 1. Purpose and Application of Planing

Planing is a form of cutting woodworking for surfaces. It makes it possible to

- manufacture flat surfaces,
- smooth wood surfaces,
- shape wood and wood-based materials.

Planing is conducive to improve quality with regard to

- surface finish of wood surfaces
- accuracy-to-size,
- accuracy of fit of connecting surfaces,
- special shaping.

## 2. Construction and Mode of Action of the Planes, Types of Planes

Planes have nearly all the same basic shape. The parts of the plane are as follows:

- plane stock (body),
- handle,
- plane hole with opening in the plane face,
- plane iron with flap,
- wedge,
- impact button,
- face,
- hand guard.

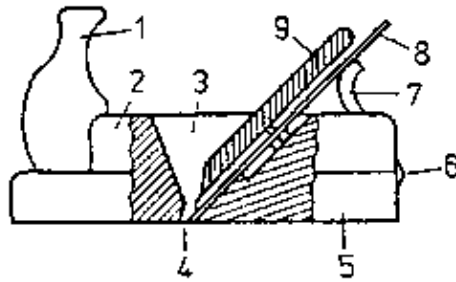

Figure 1 Parts of the plane

1 handle, 2 plane stock, 3 plane hole, 4 opening in the plane face, 5 face, 6 impact button, 7 hand guard, 8 plane iron with flap, 9 wedge

When planing, wood shavings are taken off. The plane iron is the cutting tool part. The plane iron cutting edges have a similar shape and mode of action like mortise chisel cutting edges:

- plane irons have a bevelled cutting edge at one side,
- the wedge angle at the plane iron is  $25^\circ$  to  $30^\circ$ .

The cutting effect of the plane iron cutting edge is influenced by the cutting angle. The most favourable cutting angle is between  $45^\circ$  and  $48^\circ$ . The cutting angle of a plane cannot be changed.

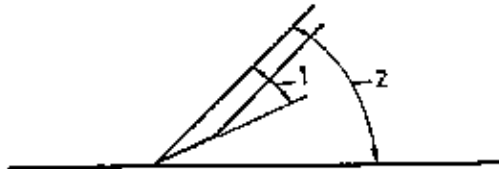

Figure 2 Wedge angle and cutting angle

1 wedge angle at the plane iron, 2 cutting angle at the plane

When planing, the cutting edge of the plane iron is pressed into the wood and splits off the shaving when the plane is advanced (pushed). The pre-splitting effect of the plane iron has to be reduced to produce a smooth surface.

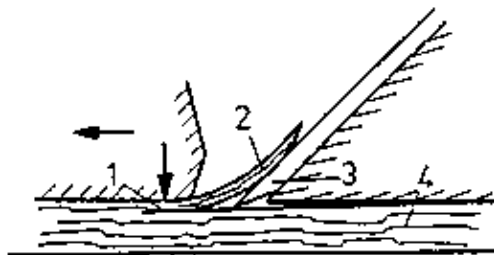

Figure 3 Mode of action of the plane iron

1 pre-splitting, 2 wood shaving, 3 plane iron cutting edge, 4 workpiece (wood)

For this purpose the plane has

- a narrow opening in the plane face to break the shaving immediately when it is lifted at the front edge of the opening,
- a flap bolted on the plane iron to additionally break the shaving at the breaking edge.



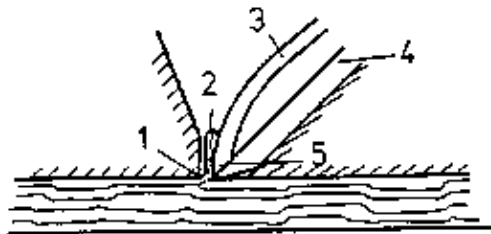

Figure 4 Breaking of the wood shaving

1 breaking edge of face opening, 2 shaving, 3 flap, 4 plane iron, 5 breaking edge at flap

The flap must

- lie closely on the plane iron,
- only be arranged max. 1 mm behind the cutting edge,
- tightly be bolted to the plane iron.

The plane stock is mainly made of hardwood, sometimes metal is also used.

Different planes are used for different requirements and working tasks, but all planes have generally the same construction. Table 1 represents the most common planes with their characteristic features and their application.

**Table 1: Types of Planes**

Designation	Features	Application
Jack plane	<ul style="list-style-type: none"> <li>- plane length: 240 mm</li> <li>- plane iron width: 30 mm</li> <li>- no flap</li> <li>- cutting edge slightly rounded</li> <li>- wide plane opening</li> </ul>	<ul style="list-style-type: none"> <li>- to remove thick shavings</li> <li>- to coarsely plane uneven surfaces of wood</li> </ul>
Finish plane	<ul style="list-style-type: none"> <li>- plane length: 240 mm</li> <li>- plane iron width: 48 mm</li> <li>- no flap</li> <li>- straight cutting edge</li> <li>- wide plane opening</li> </ul>	<ul style="list-style-type: none"> <li>- to flatten surfaces of wood</li> <li>- to coarsely smooth surfaces</li> </ul>
Double plane	<ul style="list-style-type: none"> <li>- plane length: 220 to 240 mm</li> <li>- plane iron width: 48 mm</li> <li>- bolted flap</li> <li>- straight cutting edge</li> <li>- narrow plane opening</li> </ul>	<ul style="list-style-type: none"> <li>- to flatten and smooth pre-worked surfaces of wood</li> <li>- to provide bolts and slats with bevelled edges</li> </ul>
Trying plane	<ul style="list-style-type: none"> <li>- plane length: up to 600 mm</li> <li>- plane iron width: 57 mm</li> <li>- bolted flap</li> <li>- straight cutting edge</li> <li>- special handle</li> </ul>	<ul style="list-style-type: none"> <li>- to flatten large wood surfaces and narrow faces</li> <li>- to provide long bevelled edges</li> </ul>
Rabbet plane	<ul style="list-style-type: none"> <li>- plane length: 200 to 300 mm</li> <li>- plane iron width: 8 to 33 mm acc. to the width of plane stock</li> <li>- without or with flap</li> </ul>	<ul style="list-style-type: none"> <li>- to provide profiles on board edges and narrow faces</li> <li>- to finish rabbets</li> </ul>

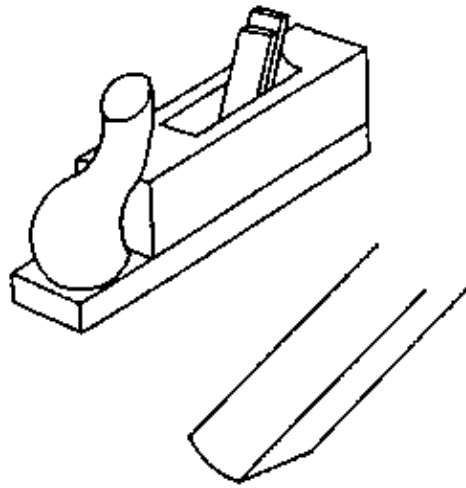

Figure 5-1 Various planes: jack plane

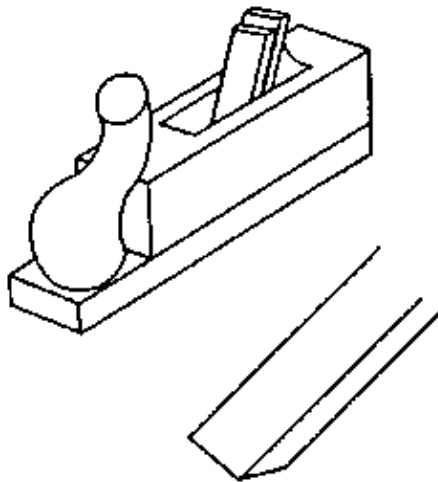

Figure 5-2 Various planes: finish plane

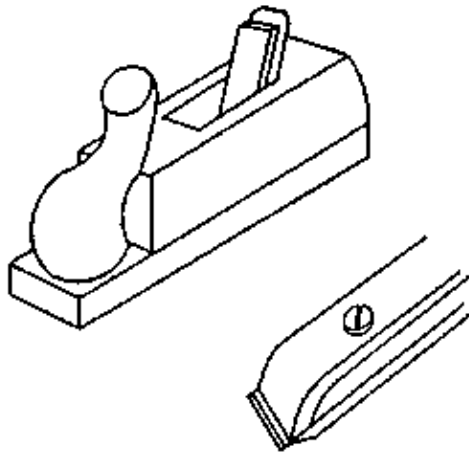

Figure 5-3 Various planes: double plane

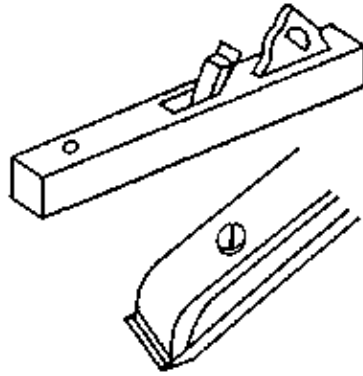

Figure 5-4 Various planes: trying plane

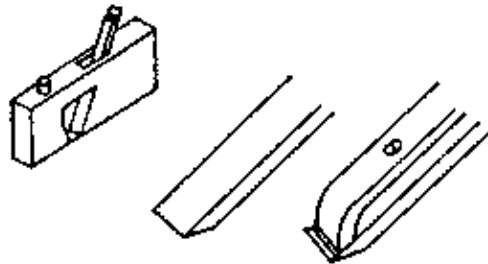

Figure 5-5 Various planes: rabbet plane

For special work, planes with

- bent face,
- shaped face and appropriately shaped plane irons,
- special bodies and plane irons, e.g. to plane out recesses in surfaces, are used.

### 3. Preparations for Planing

#### Sharpening of Plan Irons

Planes having a dull cutting edge require strenuous planing efforts and leave improper surfaces.

Dull plane irons have to be sharpened!

For sharpening of the plane iron, it is removed from the plane stock by means of blows of a hammer on the impact button.

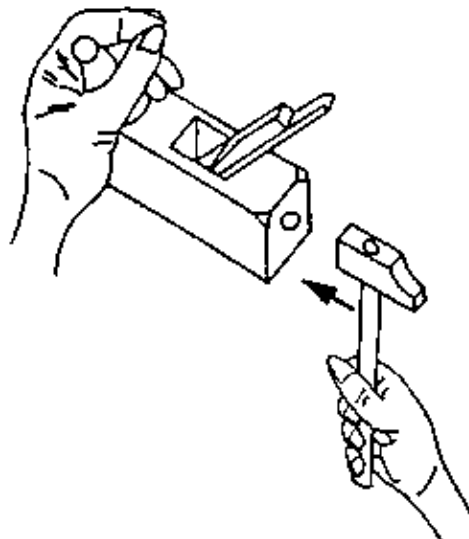

Figure 6 Removal of the plane iron from the plane stock

## Double plane

It is not allowed to beat onto the cutting edge of the plane iron!

- The flap at the plane iron is loosened and removed by means of a screw driver.

The plane iron is sharpened in two working steps:

- The plane iron is ground by means of a grinding wheel.
  - . The plane iron cutting edge has to be kept in opposite direction to the direction of rotation wheel.
  - . In order to avoid burning out of the cutting edge, the grinding wheel is permanently moistened with water.
  - . The plane iron is clamped into a movable clamping device, if possible.
  - . The wedge angle to be adjusted in this connection at the plane iron shall be  $25^\circ$  to  $30^\circ$ .
  - . The wedge angle at the plane iron can be checked by means of a protractor.

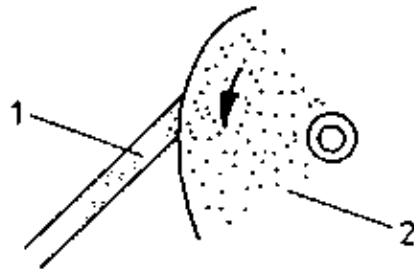

Figure 7 Grinding of the plane iron by a grinding wheel

*1 plane iron cutting edge, 2 grinding wheel*

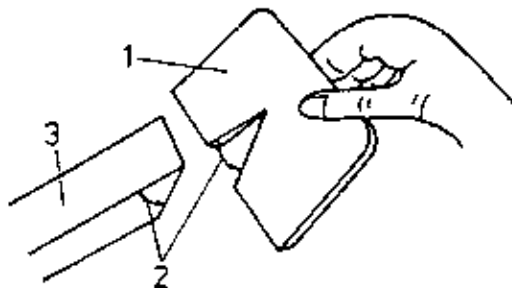

Figure 8 Checking of the wedge angle at the plane iron

*1 protractor, 2 wedge angle, 3 plane iron*

## Task

Manufacture a reference gauge with an opening angle of  $30^\circ$  from a piece of plywood or similar solid material.

- Grinding of the plane iron has to be effected until the flank has uniform concaving and the cutting edge is square to the plane iron edge.

Figure 9 shows correctly and incorrectly ground cutting edges.

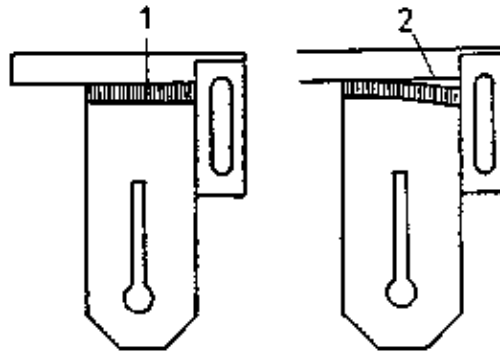

Figure 9 Square grinding of the plane iron cutting edge

*1 correctly ground, 2 incorrectly ground*

– Subsequently, the plane iron is stoned on a whet-stone made of natural or synthetic material and the burrs produced by grinding are removed. In order to achieve the required sharpness of the cutting edge, the following working steps have to be carried out:

- . moisten the whet-stone with oil or water;
- . place the flank and the cutting face of the plane iron onto the stone in alternating mode and move them over the entire surface with circular moves until the burrs are taken off and the cutting edge is sharpened.

– When stoning the plane irons of the double plane and the adjustable iron plane, the edge corners have to be slightly rounded.

– Plane irons for jack planes or planes having shaped faces are ground by means of special devices and grinding stones according to their shapes of the cutting edges.

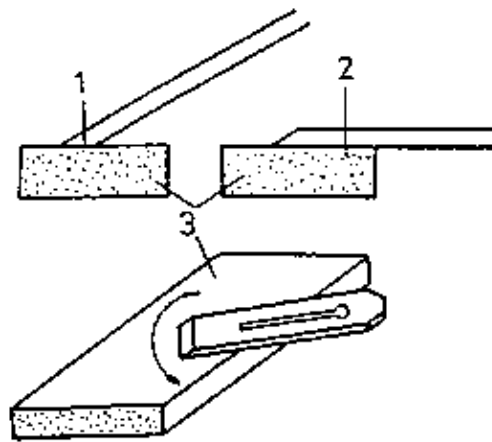

Figure 10 Stoning of the plane iron

*1 flank, 2 cutting face, 3 whet-stone*



Figure 11 Rounding of edge corners at the plane iron

What characteristic features must a well sharpened plane iron have?

---

Why is it necessary that the edge corners (between primary and secondary cutting edges) are slightly rounded?

---

After sharpening, the plane iron is inserted. In this connection, it has to be taken care for:

- adjusting the shaving thickness intended until the desired excess length of the plane iron at the face is achieved;
- final wedging of the plane iron.

The correct adjustment of the flap with its breaking edge to the plane iron cutting edge and to the breaking edge in the face opening is very important for reaching a smooth surface when planing! Exactly adjusted and sharp planes "hiss" during planing!

### Maintenance of Planes

The face of a plane has to be completely flat. But after having used it for a long period, it is worn before the cutting edge to a greater extent than behind it and that is why it has to be levelled at certain intervals.

Levelling is effected as follows:

- retract and wedge the plane iron,
- place abrasive paper onto a solid and even surface,
- grind the face on the abrasive paper until it is flat again,
- oil the face.

In case of greater unevenness at the face it has to be planed by means of a plane prior to grinding. The face opening is enlarged and the distance between the breaking edges is also increased by frequent levelling of the face. In order to re-establish the right distance it is possible to insert an appropriately shaped piece of hardwood into the face. The face must be levelled, ground and oiled after the adhesive is hardened.



Figure 12 Insertion of a piece of hardwood into the plane face

*1 inserted piece of hardwood, 2 face opening*

### Preparation of Workpieces and Workplace

Workpieces to be planed must completely be free of:

- impurities caused by sand, coarse dust or sticking impurities of other kind;
- paints and paint traces soaked into the wood;
- nails, bolts or other metallic parts.

The following wood is not suited to be planed:

- Wood showing growth defects such as:
  - . great knots,
  - . splits,
  - . arched or wrenched grain structure;
- organic defects such as:
  - . insect pest,
  - . decay,

- too high moisture content.

For planing, a working height of 700 mm to 800 mm is advisable. In the workshop, the workpieces are fixed into a carpenters' bench. Long workpieces are supported by a stand adjustable in height at the end which is not fixed.

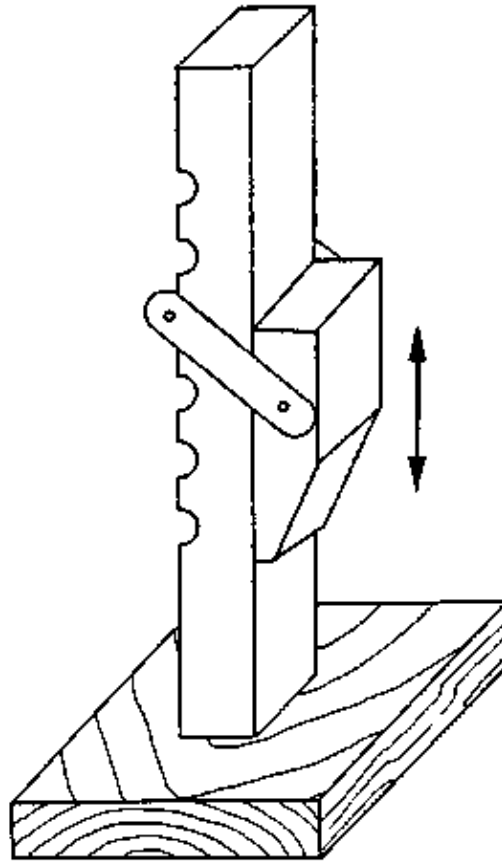

Figure 13 Adjustable workpiece stand

For site work, the trainee can manufacture a workbench by himself. It consists of:

- stand made of squared timber,
- braces made of slats or boards,
- plate made of boards, at least 30 mm thick.

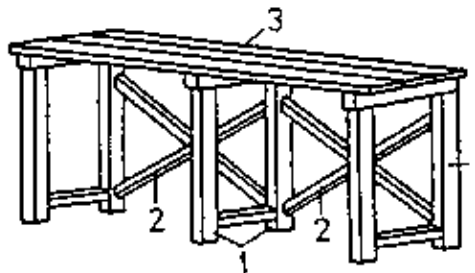

Figure 14 Site workbench

*1 squared timber, 2 braces, 3 plate*

A clamping board and a stop strip nailed onto the plate hold the workpiece in place in working direction and laterally when planing. The thickness of the clamping board and of the stop strip should always be smaller than the workpiece to be planed.

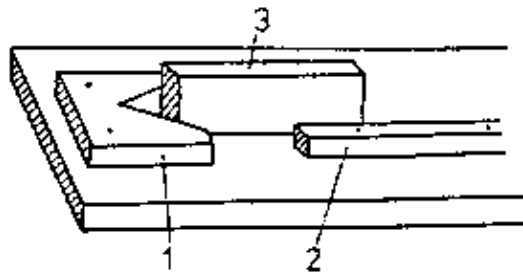

Figure 15 Clamping board to plane on sites

1 clamping board, 2 stop strip, 3 workpiece

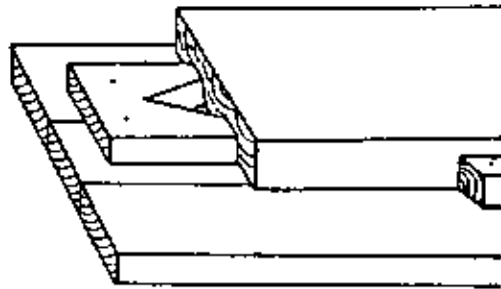

Figure 16 Clamping board and strip as stops for planing of the work-piece thickness

### Working Rules for Planing

The correct working direction for planing of workpieces in longitudinal direction is always in the direction of the ascending wood grains.

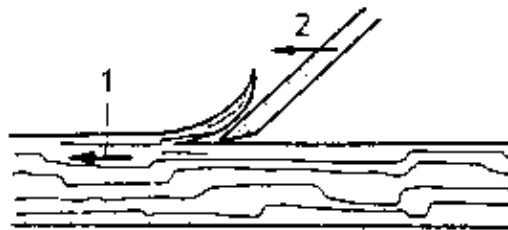

Figure 17 Correct working direction for planing

1 direction of wood grains, 2 working direction

When planing against the direction of the grains, no smooth surface can be achieved!

It is possible to plane across the direction of the grains up to an angle of 45°.

When planing narrow faces of cross-cut wood (sectional area) the plane must be moved only up to the centre of the face. The thickness of the shavings to be cut is dependent on the plane iron's excess length over the face.

The excess length is varying according to quality requirements and its adjustment must be tested:

- great excess length of the plane iron requires strenuous effort for planing and leaves uneven surfaces;
- little excess length requires little efforts and leaves flat and smooth surfaces.

The following rules are valid for working with planes:

- The workpiece has to be fixed or has to be secured immovably in working direction.
- The plane iron has to be sharp and the plane must be in working order.
- Both hands press and push against the plane:



- . When starting pressure is applied at the front on the plane.
- . The face must always be placed on the wood with its entire surface.

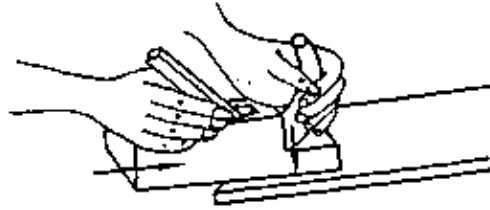

Figure 18 Applying the plane (starting of planing)

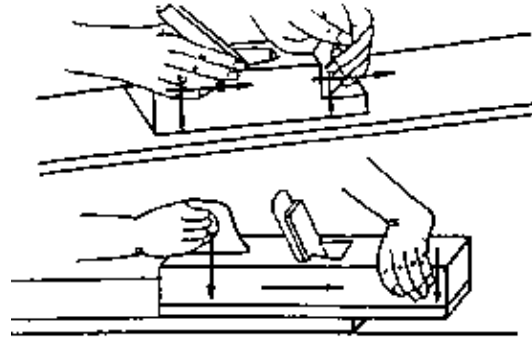

Figure 19 Moving the plane

- . When finishing, pressure is applied at the rear on the plane;
- . when returning, the plane is tilted laterally.

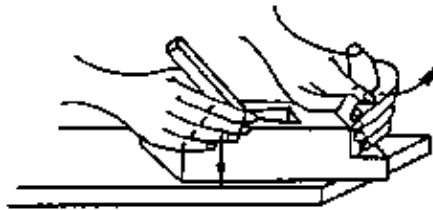

Figure 20 Taking off the plane (finishing of planing)

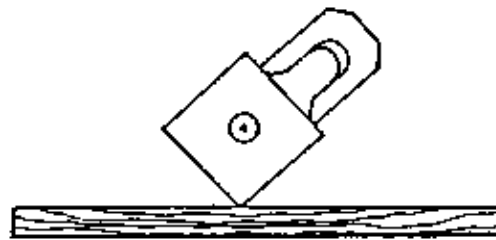

Figure 21 Returning the plane

What basic rules have to be observed when planing?

The flatness of planed surfaces is checked by:

- Comparison of the planed surface with a straight strip (straightedge) according to the light-gap method.
- Sighting over two parallel strips arranged crosswise
  - . the surface is flat when the edges of the strips are congruent;
  - . the surface is not flat (inclined) when the edges are not congruent.

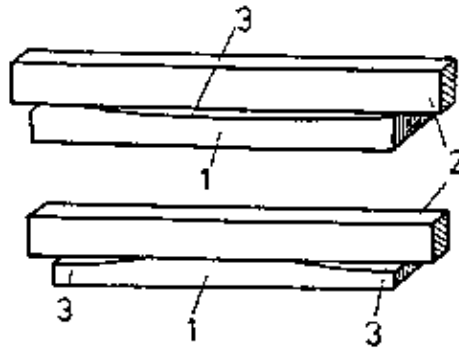

Figure 22 Checking of straightness of the workpiece

1 workpiece, 2 strip (or straightedge), 3 light gap

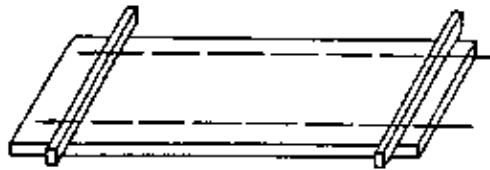

Figure 23 Checking of flatness of the surface by sighting over 2 strips

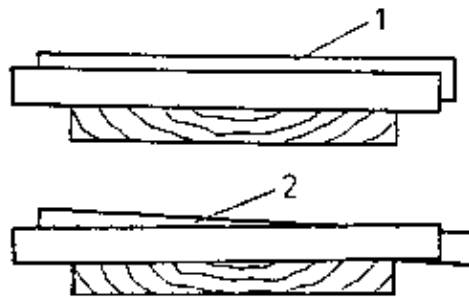

Figure 24 Checking of flatness of the surface by sighting over 2 strips

1 surface is flat, 2 surface is not flat

#### 4. Planing of Wide Faces

Flattening and smoothing of larger wide faces are effected in the working steps:

- surfacing,
- finishing.

In the case of surfacing, the coarse unevenness of the cut surface is planed:

- very uneven and rough surfaces are first planed by means of the jack plane and then by the smooth plane;
- surfaces being uneven and rough to a smaller extent are planed by the double plane and the adjustable iron fore plane.

Finishing is the removal of last irregularities and smoothing of the surface by means of the double plane and the adjustable iron fore plane:

- the plane iron must cut a thin shaving only,
- the planing pushes shall be effected as long as possible and
  - . must be placed in parallel,
  - . must overlap each other a little bit.

Why is it only allowed to cut a thin shaving when finishing?

---

When planing a workpiece to the required thickness, then:

- the face facing the trunk centre is planed first;
- the dimension of the thickness is marked out by means of a marking gauge on the narrow faces starting from the planed wide face;
- the opposite wide face is planed by means of the jack plane, the double plane and the adjustable iron fore plane up to the marked thickness.

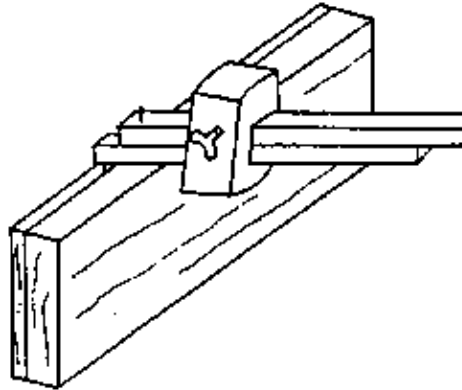

Figure 25 Marking out of the workpiece thickness by means of marking gauge

## 5. Planing of Narrow Faces

Rectangular narrow faces are planed in the following working steps:

- Coarse unevenness is removed by the jack plane and the smooth plane.
- Subsequently, the narrow face is worked by means of the trying plane,
  - . the trying plane is moved completely over the total length of the workpiece;
  - . a square, planed strip held by one hand at the face of the plane facilitates the rectangular move of the trying plane.

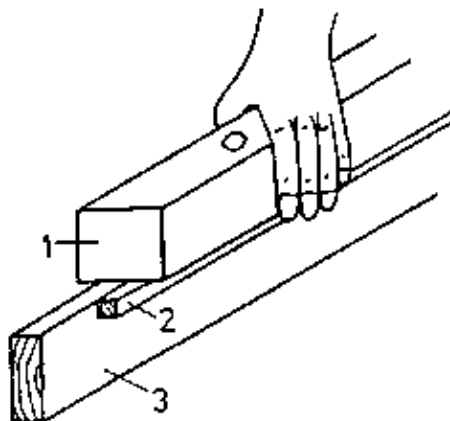

Figure 26 Handling of the trying plane for planing of narrow faces

*1 trying plane, 2 held strip, 3 workpiece*

Exact planing of rectangular narrow faces is checked as follows:

- Straightness by
  - . applying a batten onto the narrow face;
  - . joining workpieces belonging together according to the light-gap method.
- Squareness by placing a 90° steel square to the wide face.

When sighting, a hardly noticeable light gap must be visible between the square and narrow face.

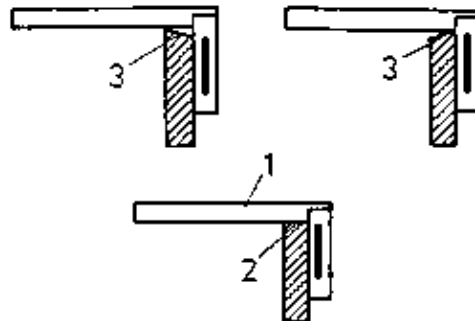

Figure 27 Checking of squareness of the wide face to the narrow face

*1 back square, 2 narrow face (square), 3 light gap (not square)*

## 6. Planing of End-grained Narrow Faces (Sectional Areas)

Planing of narrow faces of end-grained wood places special demands on the trainees; it is effected by means of the double plane (long narrow faces are planed by the trying plane) with:

- sharp plane iron,
- precisely adjusted thickness of shavings.

Rectangular narrow faces of end-grained wood are planed by short planing pushes from the two outer sides inwards.

Do not push the plane too far beyond the centre of the face otherwise the fibres would tear out!

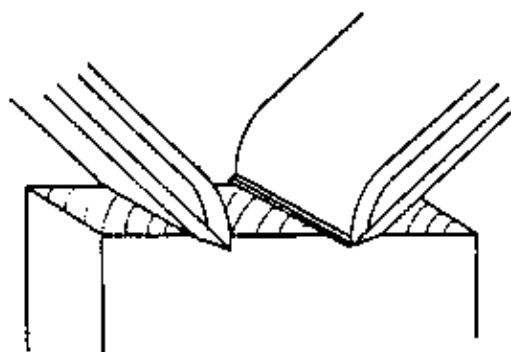

Figure 28 Working directions for planing of narrow faces of end-grained wood

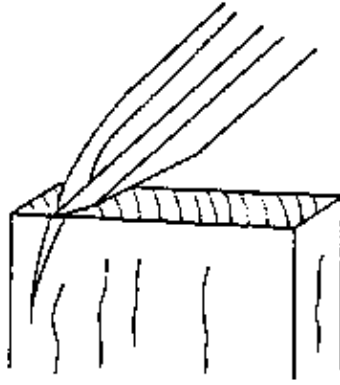

Figure 29 Tearing out of wood fibres when handling the plane incorrectly

The flatness and squareness to all sides of the narrow face are checked by:

- an applied straightedge
- a 90° steel square placed against the wide and narrow faces.

Inclined narrow cut faces are worked only in the direction of the ascending wood grain.

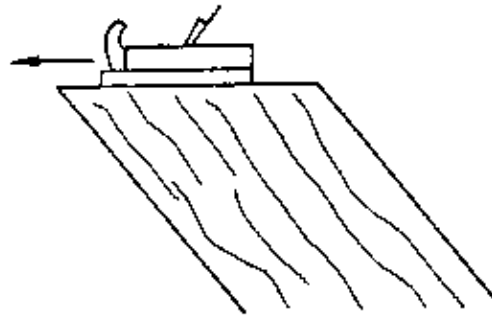

Figure 30 Working direction for planing of inclined narrow cut faces

## 7. Planing of Profiles

Profiles on longitudinal narrow faces and board edges are mostly pre-worked by means of special planes. Profiles, which are pre-moulded by woodworking machines, must be refitted or smoothed by special planes.

Simple chamfers on workpieces are worked by means of the double plane and the adjustable iron fore plane.

Tongues and rabbets are worked by means of the rabbet plane. If rabbets are worked manually, a straight, square strip (straightedge) must be mounted onto the workpiece as gauge for the accurate-to-size guidance of the rabbet plane.

If the workpieces are profiled across to the direction of the grains, the plane is moved in the same way as for planing of end-grained narrow faces.

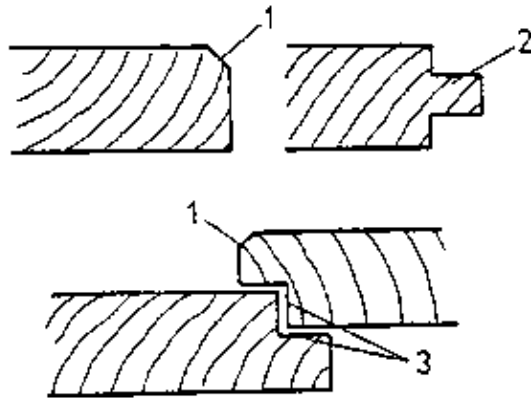

Figure 31 Profiles at narrow faces and edges

1 chamfer, 2 tongue, 3 rabbet

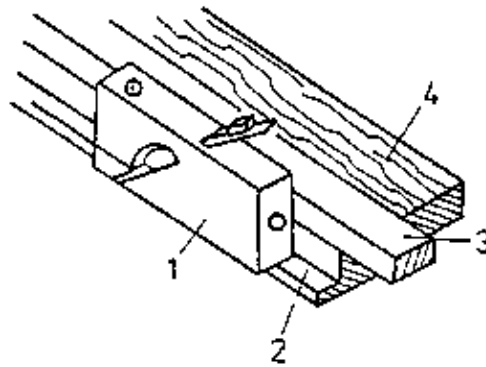

Figure 32

1 rabbet plane, 2 rabbet, 3 guide strip (straightedge), 4 workpiece

**Operations on Smooth Miller and Thicknessing Miller – Course:  
Mechanical woodworking techniques. Methodical guide for instructors**





# Table of Contents

<b><u>Operations on Smooth Miller and Thicknessing Miller – Course: Mechanical woodworking techniques. Methodical guide for instructors</u></b> .....	1
<u>1. Aims and Contents of the Training in the Working Techniques of “Working at Smooth and Thicknessing Millers”</u> .....	1
<u>2. Organizational Preparation</u> .....	1
<u>2.1. Planning the Training in the Working Techniques of “Working at Smooth and Thicknessing Millers”</u> .....	2
<u>2.2. Preparation of Labour Safety Instructions</u> .....	2
<u>2.3. Making Available the Necessary Teaching Aids</u> .....	2
<u>2.4. Making Available Working Materials</u> .....	2
<u>3. Recommendations for the Realization of the Training in the Techniques of “Working at Smooth and Thicknessing Millers”</u> .....	3
<u>3.1. The Introductory Instruction</u> .....	3
<u>3.2. Exercises</u> .....	5
<u>3.3. Examples for Recapitulation and Tests</u> .....	7



# **Operations on Smooth Miller and Thicknessing Miller – Course: Mechanical woodworking techniques. Methodical guide for instructors**

**Institut für berufliche Entwicklung e.V.  
Berlin**

Original title:  
Methodische Anleitung für den Lehrenden  
“Arbeiten an Abricht- und Dickenfräsmaschinen”

Author: Johannes Schollbach

First Edition © IBE

Institut für berufliche Entwicklung e.V.  
Parkstraße 23  
13187 Berlin

Order No.: 93–32–3402/2

## **1. Aims and Contents of the Training in the Working Techniques of “Working at Smooth and Thicknessing Millers”**

After having finished their training based on this lesson, the trainees shall have achieved the following aims:

- They know the construction and the function of the smooth miller and the thicknessing miller.
- They are able to mill broad and narrow faces plane, angular and to thickness.
- They can control by themselves the quality of the milled surfaces.
- They know that correct milling of the broad and narrow faces is decisive for the further treatment of the workpieces.
- They know the danger of accident and the use of protection devices and auxiliaries for the prevention of accidents.

In order to achieve the above aims, the following contents must be taught.

### **Contents**

- Purpose of milling
- Construction and function of the smooth miller and the thicknessing miller
- Operating sequence of milling.

## **2. Organizational Preparation**

In order to ensure that the instructions, demonstrations and exercises go off smoothly, the training must be well prepared.

This includes the following measures:

## **2.1. Planning the Training in the Working Techniques of “Working at Smooth and Thicknessing Millers”**

- The theoretical teaching is done in a class room or in other suitable facilities with one group of trainees.
- After that the instructor demonstrates how to work at the smooth and thicknessing miller.
- The following exercises are done by one trainee only. (The order of the trainees is set up before.)
- Waiting periods for the rest of the trainees are bridged by other job orders.
- It is recommendable to make a time schedule for the before mentioned training sections.

This time planning depends on the training conditions given.

## **2.2. Preparation of Labour Safety Instructions**

Prior to the demonstrations and exercises the trainees must be instructed in brief on how to prevent accidents.

It is recommended to prepare a book and to note down all instructions given. The trainees should then confirm by their signature that they have been instructed accordingly.

The priorities are:

- Safety devices at the machine are not to be removed or to make ineffective.
- Make use of auxiliaries to avoid accidents.
- Detected faults affecting the operational security of the machine are subject to registration. The machine must be immediately switched off.
- Make use of ear protectors when working.
- The working place must be permanently in good order.

## **2.3. Making Available the Necessary Teaching Aids**

- The theoretical instructions should be given at a place where the trainees are able to make notes, preferably a class-room with desks and blackboard or with seatings and tables.
- Demonstration models of unmachined and machined broad and narrow faces are to make available.
- The Trainees' Handbook of Lessons “Working at Smooth and Thicknessing Millers” is to hand over to each trainee.

## **2.4. Making Available Working Materials**

- The working material “Instruction Examples for Practical Vocational Training – Milling at Smooth and Thicknessing Millers” is to be handed out to the trainees before starting the exercises.
- The following machines are recommended as basic equipment for the training in the course “Machining of Material”: band sawing machine, circular saw, bench smooth miller, thicknessing miller, drilling machine, shaping machine, wood turning lathe, grinding machine, top spindle moulder.
- The materials which are necessary for carrying out the exercises should be prepared in a sufficient number based on the workshop sketches of the instruction examples “Milling at Smooth and Thicknessing Millers”.

- Feeding disk, solid steel squares, slide gauge and folding rule are to be prepared.
- Before starting the exercises check the smooth and thicknessing millers for functionality and safety according to the labour safety requirements.

### **3. Recommendations for the Realization of the Training in the Techniques of “Working at Smooth and Thicknessing Millers”**

The following sections give recommendations as there are the teaching of the trainees, the demonstrations in the working method and how to do the exercises and controls.

#### **3.1. The Introductory Instruction**

The introductory instruction should be given in a room having desks and seatings for the trainees.

The instruction should predominately be given in the form of a lecture including a question – answer talk with the trainees. Demonstration models and existing pictures should be used as teaching aids.

Special emphasis should be given to the danger of accidents and the observance of labour safety.

The “Trainees' Handbook of Lessons” corresponds in its structure to the introductory instruction. The main points with respect to the content can be taught in the given order. During the instruction the trainees are to be urged to note down necessary complements or answers to questions in their “Trainees' Handbook of Lessons”.

#### ***Purpose of milling at the smooth miller:***

By comparing the machined and unmachined workpieces demonstrate the trainees the purpose of milling.

It is recommendable to make use of demonstration models.

#### ***Construction and mode of operation of the smooth miller:***

The instruction on the construction and the mode of operation of the smooth miller is to be given at the machine.

The trainees are to take their place at the smooth miller and the instructor has to take care that everyone can see his operation and no trainee stands behind his back. The following has to be shown to the trainees at a secured machine (secured against unintended starting):

- method of operation of the cutter spindle
- adjustability of the tables
- adjustability of the stop bars
- mode of operation of the safety devices
- putting the workpieces on the feeding table and guiding them via the cutter spindle to the unloading table
- pressure shift of the hands during milling
- possibilities for making use of auxiliaries for preventing accidents
- After this demonstration the machine is to start for a short time paying attention to the labour safety regulations in order to make the trainees familiar with the noise intensity of the

machine.

- Point out the necessity of ear protectors.

### **Setting of the smooth miller and milling of the workpieces**

Now demonstrate the milling of broad and narrow faces. Show the trainees how to correctly put the workpieces on the feeding table, to set the cutting depth and to guide the workpieces over the cutter spindle to the unloading table. After that stop the machine.

All movements done during milling should be explained by the trainees once again.

The trainees must be shown how to check their milling work. They must recognize that milling surfaces in good quality is important for the further treatment of the workpieces.

The exemplary work and handling of the instructor who gives the demonstrations is decisive for the motivation of the trainees who have to master this work by themselves at the end of this course.

### **Milling at the thicknessing miller**

The introductory instruction on “Milling at the Thicknessing Miller” is to be done in the same way like the instruction on “Milling at the Smooth Miller”.

#### ***Purpose of milling at the thicknessing miller:***

Workpieces machined on the smooth miller are finished to size at the thicknessing miller. Show the trainees milled broad and narrow faces on demonstration models.

#### ***Construction of the thicknessing miller:***

Do the instruction on the construction of the thicknessing miller at the machine.

The trainees are to take their places in such a way that everyone can see the operations of the instructor.

Demonstrate the trainees at a secured machine (secured against unintended switch on) the following:

- mode of operation of the cutter spindle
- mode of operation of the feeding rollers
- switch on and switch off the feeding gear
- purpose and mode of operation of the pressure beams
- mode of operation of the rebound protection
- adjustability of the machine table
- mode of operation of the table rollers
- adjustability of the rate of feed
- After this demonstration the machine is to start for a short time paying attention to the labour safety regulations in order to make the trainees familiar with the noise intensity of the machine.
- Point out the necessity of ear protectors.

### **Setting of the thicknessing miller and milling of the workpieces**

Now demonstrate the milling of broad and narrow faces. Demonstrate the trainees the correct placing of the workpiece on the machine table and the pushing in up to the point it is picked up by the feed roller.

After that switch off the machine. Carry out dimensional inspection. All movements done during milling should be explained by the trainees once again.

Emphasis should be given to:

- setting of the given dimensions
- push in the workpieces parallel to the machine edge
- taking notice of the maximum chip removal
- adjustability of the rate of feed
- milling of working parts being of different thickness.

The exemplary work and handling of the instructor who gives the demonstration is decisive for the motivation of the trainees who have to master this work by themselves at the end of this course.

They must recognize that milling of surfaces accurate to measurement and in good quality is important for the further treatment of the workpieces.

Dimensional inspection is to be done by the trainees themselves.

### **3.2. Exercises**

The introductory instruction followed by demonstration was done **with one group of trainees**.

Often there is no more than one machine available. Therefore the exercises can be done by one trainee only.

The order of the trainees for doing the exercises should be fixed during the introductory instruction.

Having finished the course “Manual Working of Material – Planing” the trainees have good previous knowledge of the purpose of surface treatment.

The previous demonstrations showed the trainees the method of milling broad and narrow faces at the smooth and thicknessing miller.

The exercises should be done according to the “Instruction Examples for Practical Vocational Training”. They contain specifications of the necessary material and auxiliaries as well as of measuring and testing tools.

They also describe the sequence of operations. Again a short teaching instruction should be prepared for each exercise which shows the trainees a finished workpiece.

#### ***Instruction examples***

In order to give a survey of the practising pieces which should be made to apply the imparted knowledge, each instruction example is briefly prescribed in the following:

##### **Instruction example 2.1: Frame piece**

The broad face of a ledge is milled to get a plane surface.

##### **Instruction example 2.2: Frame piece**

The narrow face of the ledge of instruction example 1 is milled at an angle of 90° to the broad face.

##### **Instruction example 2.3: Frame piece**

The surfaces of the ledge being machined in the preceding instruction examples are milled to thickness.

##### **Instruction example 2.4: Grating**

Practice the milling of broad and narrow faces on the smooth and thicknessing miller for the production of ledges for a bar grate.

#### **Instruction example 2.5.: Wall shelf**

Practice the milling of broad and narrow faces of piece parts at the smooth miller.  
Practice milling to thickness and to width on the thicknessing miller.  
After that the piece parts are to be assembled.

#### **Instruction example 2.6.: Frame**

Practice the milling of broad and narrow faces to thickness and to width in order to produce frame ledges.

It is possible to choose other practising pieces than those given in the instruction examples if they are suited to practice the technique of milling on the smooth and thicknessing miller.

The instructor must have produced the practising piece by himself to know all the problems of its production. The instruction examples must have been presented to the trainees so that they can look up or reread and take notes.

The trainee works alone and machines the workpiece by himself starting with cutting to size of the basic material carried out in the course "Working at Circular Sawing Machines" up to the finished workpiece.

The working examples should be marked with the names of the trainees

- to rate the training results separately or in complex
- to explain the trainees the importance of working in best quality when joining piece parts to final products.

Under supervision and direction of the instructor the exercises are carried out by the trainees. They should never do their exercises without supervision.

The trainees should make use of ear protectors. Only one trainee is working at the machine. Several trainees may distract each other and thus cause accidents. The remaining trainees of the group are to keep busy with other jobs. Before starting the exercise the trainees should be informed on the criteria of evaluation.

Criteria of evaluation may be:

#### **Setting of the smooth miller**

- Has the working width been set correctly?
- Has the depth of cut been set correctly?
- Are the workpieces placed at hand?

#### **Working at the smooth miller**

- Were the workpieces put on the feeding table in the right way?
- Has the workpiece been guided over the cutter spindle under the right pressure shift?
- Have the machined workpieces been put away correctly?
- Did the trainee make use of ear protectors?

#### **Working at the thicknessing miller**

- Has the correct rate of feed been chosen?
- Has been taken notice of the maximum chip removal?
- Have the machined workpieces been put away correctly?
- Has been paid attention to order and cleanliness at the working place?
- Did the trainee make use for ear protectors?

#### **Control of quality**



- Did the trainee check his machined workpieces?
- Does the result meet the demands of quality?
- Are the broad faces plane all over?
- Is the narrow face at right angles to the broad face?
- Are the workpieces accurate to measurement?

Other criteria of assessment may be determined by the instructor according to the training conditions. These points of assessment too, are to make known to the trainees before starting the exercises.

### 3.3. Examples for Recapitulation and Tests

This section contains questions to strengthen and test the knowledge and skills acquired. The corresponding answers are also given. Questions marked with the letter “A” are also contained in the “Trainees' Handbook of Lessons”.

1. “A” What is the purpose of milling on the smooth miller?  
*(milling of a plane broad face and milling of a narrow face being at an angle to the broad face)*
2. How is the mode of operation of the smooth miller?  
*(chip removal by rotary movement of the cutter spindle)*
3. “A” Which setting is done at the feeding table of the mill?  
*(setting of the depth of cut)*
4. To which height is the unloading table set?  
*(to the flying circular height of the cutters)*
5. “A” What is the stop bar of the smooth miller for?  
*(It serves to guide the workpieces when milling narrow faces)*
6. “A” What is the feeding table for?  
*(for an accident–proof treatment of short workpieces)*
7. How are longer workpieces are put on the feeding table?  
*(with the hollow broadside or narrow side)*
8. Why is it not allowed to put machines into operation having no safety device?  
*(because of the high danger of accident at all woodworking machines)*
9. “A” Why is to make use of ear protectors?  
*(because of the high noise pollution of the machines)*
10. How is the planeness of the broad face controlled?  
*(by laying one workpiece on the top of the other)*
11. “A” Why is the left cover of the cutter spindle adjustable?  
*(to set the working width)*
12. Where should the workpieces to be machined be stored?  
*(ready to hand)*
13. “A” What is the purpose of milling on the thicknessing miller?  
*(to mill to thickness and width the workpieces milled on the smooth miller)*
14. Why is the machine table vertically adjustable?  
*(to set the intended thickness and width of the workpieces to be milled)*
15. “A” What are the sliding rollers in the machine table for?  
*(to reduce the friction of the workpieces on the table)*

16. How does the feed operate bringing the workpieces through the thicknessing miller?  
*(by feed rollers)*

17. "A" What should be done if there is a feed stoppage?  
*(first switch off the feed gear and than the cutter spindle)*

18. "A" Which task and function do the both pressure beams have?  
*(to prevent a flutter effect of the workpiece when milling it)*

19. "A" Which function does the rebound protection have?  
*(to prevent a throwing out of the workpiece by the cutter spindle)*

20. "A" At which rate of feed can I reach the best quality of the milled surface?  
*(at the lowest)*

21. "A" How do you check the dimensional accuracy?  
*(with the folding rule or sliding gauge)*

**Operations on Smooth Miller and Thicknessing Miller – Course:  
Mechanical woodworking techniques. Instruction examples for  
practical vocational training**



# Table of Contents

<b><u>Operations on Smooth Miller and Thicknessing Miller – Course: Mechanical woodworking techniques. Instruction examples for practical vocational training</u></b> .....	1
<u>Preliminary Remarks</u> .....	1
<u>Instruction Example 2.1.: Frame Piece</u> .....	1
<u>Instruction Example 2.2.: Frame Piece</u> .....	3
<u>Instruction Example 2.3.: Frame Piece</u> .....	4
<u>Instruction Example 2.4.: Grating</u> .....	5
<u>Instruction Example 2.5.: Wall Shelf</u> .....	7
<u>Instruction Example 2.6.: Frame</u> .....	10



# Operations on Smooth Miller and Thicknessing Miller – Course: Mechanical woodworking techniques. Instruction examples for practical vocational training

Institut für berufliche Entwicklung e.V.  
Berlin

Original title:  
Lehrbeispiele für die berufspraktische Ausbildung  
“Arbeiten an Abricht- und Dickenfräsmaschinen”

Author: Johannes Schollbach

First edition © IBE

Institut für berufliche Entwicklung e.V.  
Parkstraße 23  
13187 Berlin

Order No.: 93–33–3402/2

## Preliminary Remarks

This material contains six selected instruction examples which are useful for applying and improving knowledge in the field of the working techniques of milling broad and narrow faces as well as of milling to thickness and width.

In order to facilitate preparations and operations, the necessary materials, machines, measuring and testing means as well as auxiliaries are specified for each instruction example.

Furthermore, the previous knowledge is mentioned that is additionally necessary for milling broad and narrow faces as well as for milling to thickness and width. It is recommended to repeat this knowledge before starting the work.

The sequence of operations specified for each instruction example includes working steps leading to the manufacture of the relevant workpiece. This order is to be absolutely observed for reaching a good quality.

A working drawing is attached to each instruction example showing the required shapes and dimensions of the workpiece. It is also possible to choose other practising pieces with smaller or bigger dimensions.

## Instruction Example 2.1.: Frame Piece

The broad face of a ledge is milled to a plane surface.

### Material

Sawn timber

Dimensions:

Length      1000 mm

Width        60 mm

Thickness    45 mm

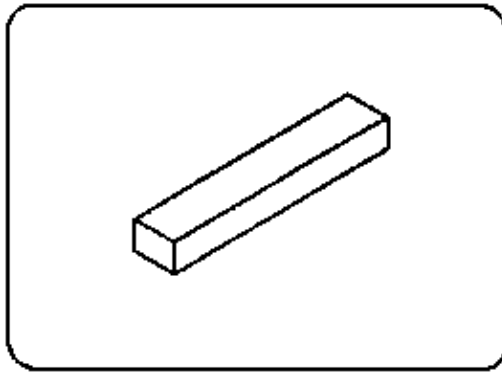
**Machine**

Smooth miller

**Measuring and testing means**

Folding rule

**Required previous knowledge**

Reading of drawings, measuring and testing, "Manual Woodworking Techniques – Planing a Narrow Face by Hand".

<b>Sequence of operations</b>	<b>Comments</b>
1. Set working width, set depth of cut and place frame pieces at disposal.	Check safety devices.
2. Switch on the machine.	Take notice of star–delta connection or direct connection. Make use of ear protectors.
3. Mill the frame piece on its broad face by hand.	Take notice of existing roughness of the broad face when guiding the workpiece. Shift the pressure step by step to the unloading table.
4. Check the milled broad face.	Check two machined workpieces by laying one on the top of the other. The broad faces must sit closely on top of one another.
5. Switch off the machine.	Possible addition: Mill wooden parts of different dimensions on their broad faces.



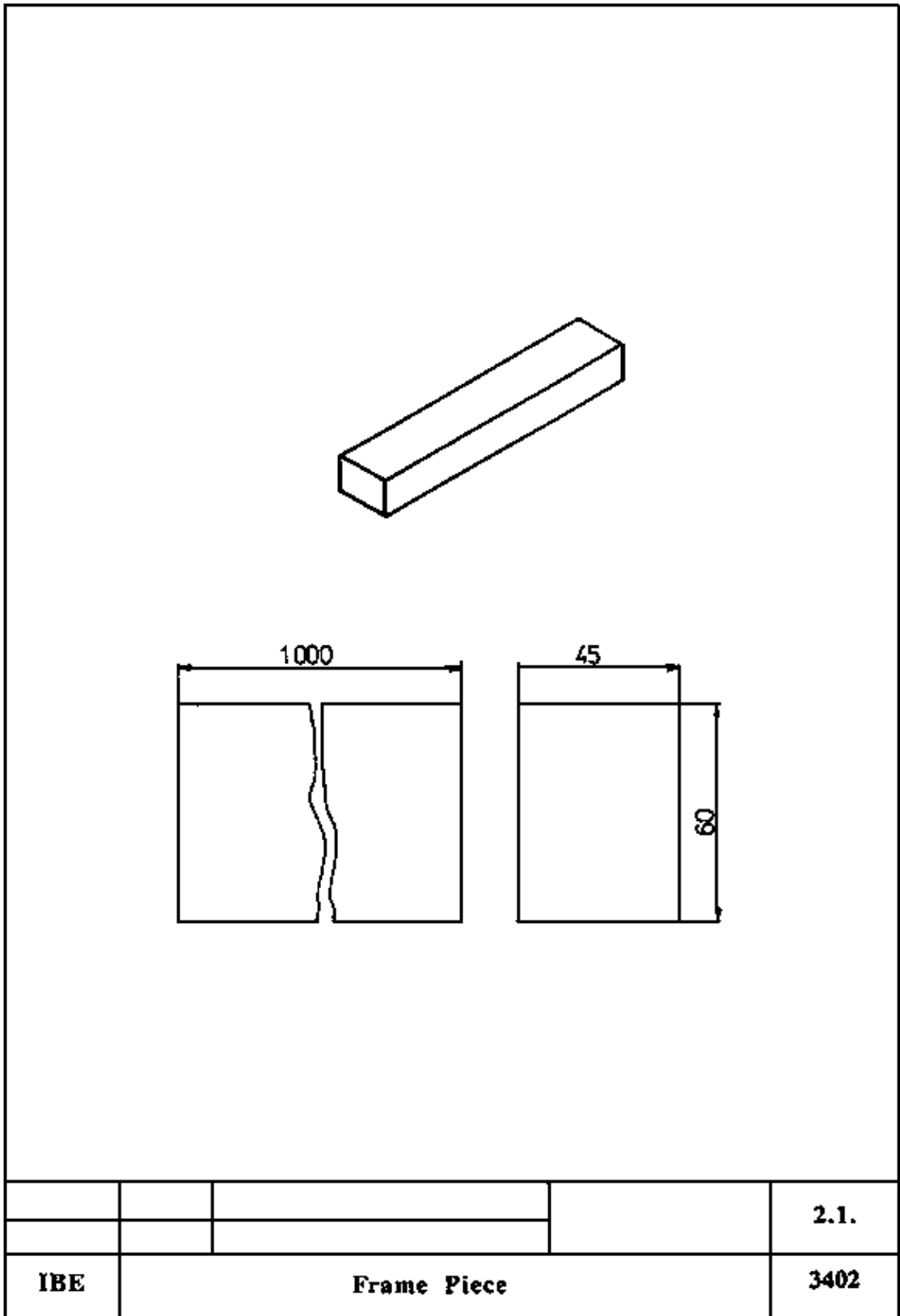

Frame Piece

### Instruction Example 2.2.: Frame Piece

The narrow face of a ledge (see Instruction Example 2.1) is milled at an angle of 90° to the broad face.

#### Material

Machined ledge from Instruction Example 2.1.

### **Machine**

Smooth miller

### **Measuring and testing means**

Solid steel squares, folding rule

### **Necessary previous knowledge**

Reading of drawings, measuring and testing, "Manual Woodworking Techniques – Planing a Narrow Face by Hand".

<b>Sequence of operations</b>	<b>Comments</b>
1. Set working width, set depth of cut, place material at disposal.	Check the safety devices, check the angle of the stop rule.
2. Switch on the machine.	Take notice of star–delta connection or direct connection, wear ear protectors.
3. Mill the frame piece on its narrow face guiding at the stop rule by hand.	The frame piece must closely sit with its broad face at the stop rule.
4. Check the milled narrow face.	The narrow face must be in the required angle to the broad face, lay one narrow face on top of the other, both must sit closely.
5. Switch off the machine.	Possible addition: Mill wooden parts of different dimensions on their narrow faces.

## **Instruction Example 2.3.: Frame Piece**

The surface of the ledge from the preceding Instruction Examples are milled to thickness.

### **Material**

Machined ledge from Instruction Example 2.2.

### **Machine**

Thicknessing miller

### **Measuring and testing means**

Folding rule, vernier caliper

### **Necessary previous knowledge**

Milling of surfaces on the smooth miller, reading of the drawing, measuring and testing, "Manual Woodworking Techniques – Planing the Broad and Narrow Faces by Hand".

<b>Sequence of operations</b>	<b>Comments</b>
1. Place the material at disposal, set the sizes on the scale of the machine.	Check rebound protection for functionality.
2. Switch on the machine.	Take notice of star–delta connection or direct connection, wear ear protectors.

3. Insert the frame piece up to the draw-in roller by hand.
4. Check the machined workpieces for dimensional accuracy.
5. Switch off the machine.

Put the workpiece with that face on the table, which has been machined on the smooth miller.

Undertake dimensional inspection, using the folding rule or vernier caliper.

Possible addition: Mill workpieces of different dimensions to thickness.

## Instruction Example 2.4.: Grating

For producing ledges for a grating, milling of broad and narrow faces on the smooth and thicknessing miller is to be practised.

### Material

4 x sawn timber

Dimensions:

Length 1000 mm

Width 80 mm

Thickness 25 mm

2 x sawn timber

Dimensions:

Length 450 mm

Width 60 mm

Thickness 25 mm

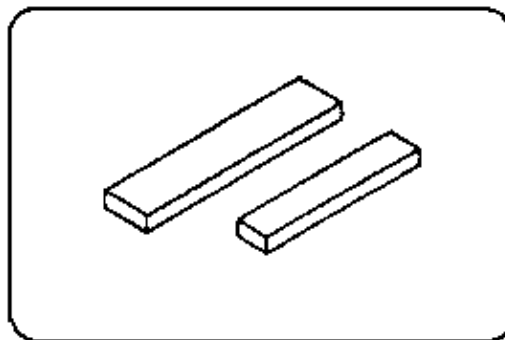

### Machines

Smooth miller, thicknessing miller

### Measuring and testing means

Solid steel squares, folding rule, vernier caliper

### Auxiliary

Feeding device

### Necessary previous knowledge

Reading of drawings, measuring and testing “Manual Woodworking Techniques – Planing the Broad and Narrow Faces by Hand”.

<b>Sequence of operations</b>	<b>Comments</b>
1. Place material at disposal, set working width and depth of cut on the smooth miller.	Check the safety devices.
2. Switch on the machine, mill a broad and a narrow surface.	Take notice of surface roughness when guiding the workpiece. When milling the short ledge, make use of the feeding device.
3. Check the milled surfaces.	Check flatness of the broad face and angularity of the narrow face.
4. Set the thicknessing miller to the required size.	Take into account maximum chip removal.
5. Switch on the machine and mill the ledges to the required thickness and width.	Do not put in workpieces of quite different thickness side by side.
6. Control dimensional accuracy.	Dimensional inspection with folding rule or vernier caliper.
7. Completion: Saw the ledge to the given length. Smooth off comers with abrasive paper. Join the ledges by bolted or nail connection.	

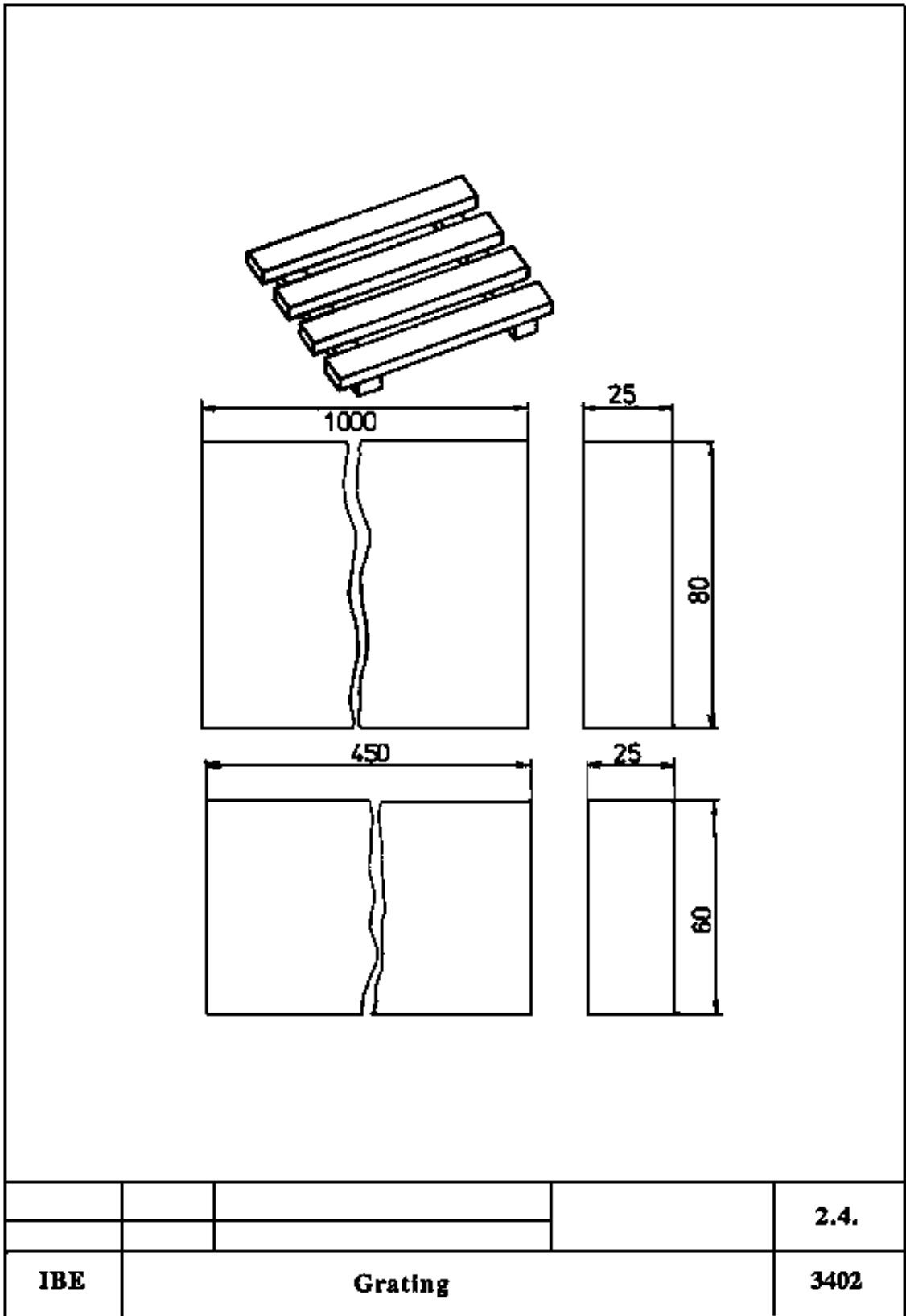

Grating

### Instruction Example 2.5.: Wall Shelf

Practise milling of broad and narrow faces on the smooth miller.

Practise milling to thickness and width on the thicknessing miller for producing piece parts for a wall shelf.

## Material

– Sawn timber

Dimensions:

Length 800 mm

Width 200 mm

Thickness 25 mm

– 2 x sawn timber

Dimensions:

Length 400 mm

Width 190 mm

Thickness 25 mm

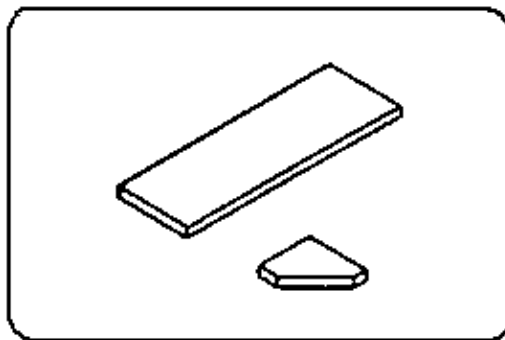

## Machines

Smooth miller, thicknessing miller

## Measuring and testing means

Solid steel squares, folding rule, vernier caliper

## Auxiliary

Feeding device

## Necessary previous knowledge

Reading drawings, measuring and testing “Manual Woodworking Techniques – Planing the Broad and Narrow Faces by Hand”.

### Sequence of operations

1. Place the material at disposal, set the working width and the depth of the cut on the smooth miller.
2. Mill a broad and a narrow face.
3. Control the broad and the narrow face.

### Comments

- Check the safety devices, make use of the ear protector.
- Take notice of surface roughness when guiding the workpiece. Make use of the feeding device.
- Check flatness of the broad face and angularity of the narrow face.

4. Set the thicknessing miller to the required dimension. Switch on the machine and mill the workpiece to thickness and width.

5. Control dimensional accuracy.

6. Completion:

Mark the piece parts according to the drawing and cut them to size. Smooth off edges and comers. Join supports and shelf by bolted connection and flat comer joint.

Take into account maximum chip removal. Do not put in workpieces which are of quite different thickness, side by side.

Dimensional inspection with folding rule or vernier caliper.

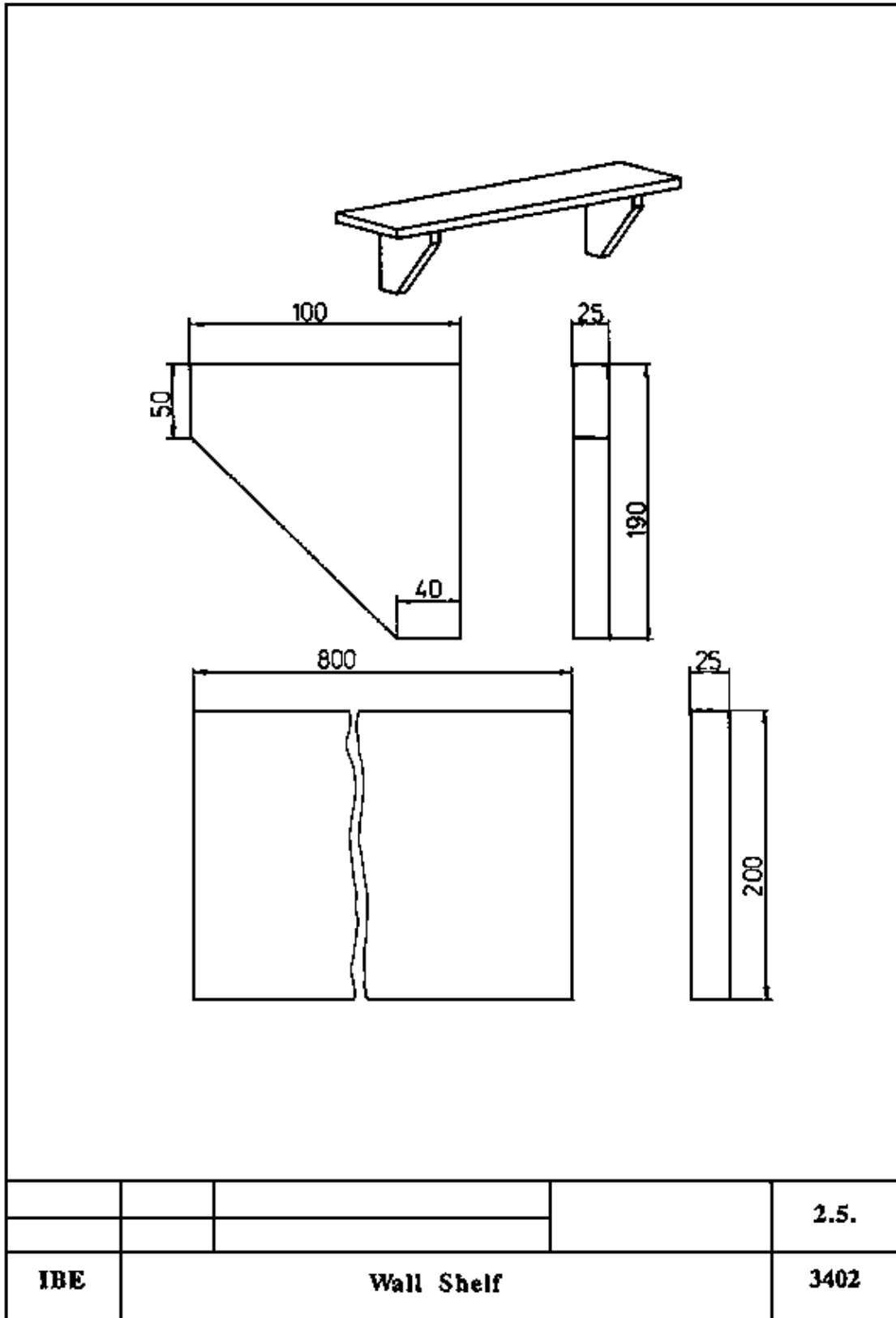

Wall Shelf

### Instruction Example 2.6.: Frame

Practise milling of broad and narrow faces on the smooth miller.

Practise milling to thickness and width on the thicknessing miller for producing frame ledges.



## Material

– 2 x sawn timber

Dimensions:

Length 2000 mm

Width 120 mm

Thickness 35 mm

– 2 x sawn timber

Dimensions:

Length 900 mm

Width 120 mm

Thickness 35 mm

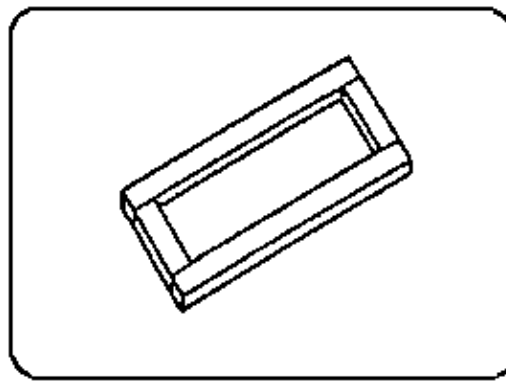

## Machines

Smooth miller

## Measuring and testing means

Solid steel squares, folding rule, vernier caliper.

## Necessary previous knowledge

Reading drawings, marking, measuring and testing, making a slotted frame connection, pasting together connections.

Sequence of operations	Comments
1. Place the material at disposal, set the smooth miller.	Check the thickness of the strip scutter, visual checking or mill a test piece.
2. Mill a broad and a narrow face.	Long workpieces require special skill for milling, do not give too much pressure to avoid deflection.
3. Control the milled broad and narrow face.	Check flatness of the broad face and angularity of the narrow face.
4. Mill to width and thickness on the thicknessing miller.	Take notice of surface roughness when guiding the workpiece.

5. Control of dimensional accuracy.

Dimensional inspection with folding rule or vernier caliper.

6. Completion:

Piece parts are to be sawn to length according to the drawing. Mark the slotted frame connection and carry out. Paste together the connection. Smooth the surfaces of the frame. Smooth off edges.

				<b>2.6.</b>
<b>IBE</b>	<b>Frame</b>			<b>3402</b>

Frame

**Operations on Smooth Miller and Thicknessing Miller – Course:  
Mechanical woodworking techniques. Trainees' handbook of lessons**



# Table of Contents

<b><u>Operations on Smooth Miller and Thicknessing Miller – Course: Mechanical woodworking techniques. Trainees' handbook of lessons</u></b> .....	<b>1</b>
<u>1. Purpose of Milling at the Smooth Miller</u> .....	1
<u>2. Construction of the Smooth Miller</u> .....	2
<u>3. Setting of the Smooth Miller</u> .....	3
<u>4. Milling of the Workpieces</u> .....	3
<u>5. Purpose of Milling on the Thicknessing Miller</u> .....	4
<u>6. Construction of the Thicknessing Miller</u> .....	4
<u>7. Setting of the Thicknessing Miller</u> .....	5
<u>8. Milling of the Workpieces</u> .....	5
<u>9. Tasks</u> .....	5



# Operations on Smooth Miller and Thicknessing Miller – Course: Mechanical woodworking techniques. Trainees' handbook of lessons

Institut für berufliche Entwicklung e.V.  
Berlin

Original title:  
Arbeitsmaterial für den Lernenden  
“Arbeiten an Abricht- und Dickenfräsmaschinen”

Author: Johannes Schollbach

First Edition © IBE

Institut für berufliche Entwicklung e.V.  
Parkstraße 23  
13187 Berlin

Order No.: 93-35-3402/2

## 1. Purpose of Milling at the Smooth Miller

Milling on the smooth miller serves for making plane broad faces as well as narrow faces being at an angle to the broad face. Milling of broad and narrow faces is the first step of machining the workpieces on the thicknessing miller. The plane faces are the determining factor for the quality of the final product.

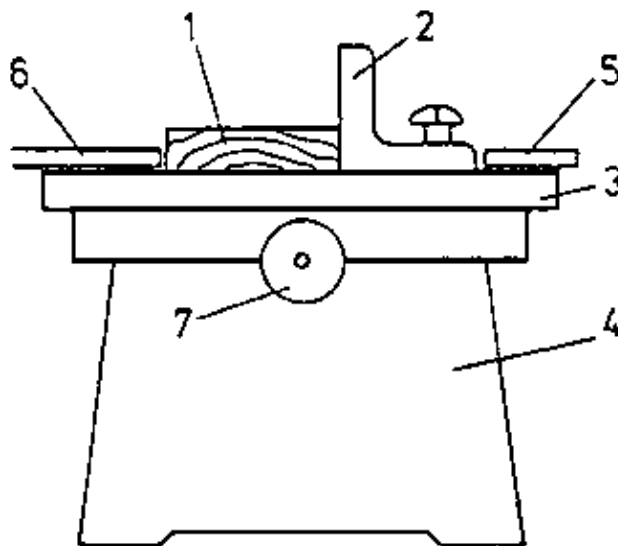

**Figure 1 – Milling of the broad face**

*1 workpiece, 2 stop bar, 3 feeding table, 4 column, 5 rear cover of the cutter spindle, 6 front cover of the cutter spindle, 7 handwheel for adjustment of table*

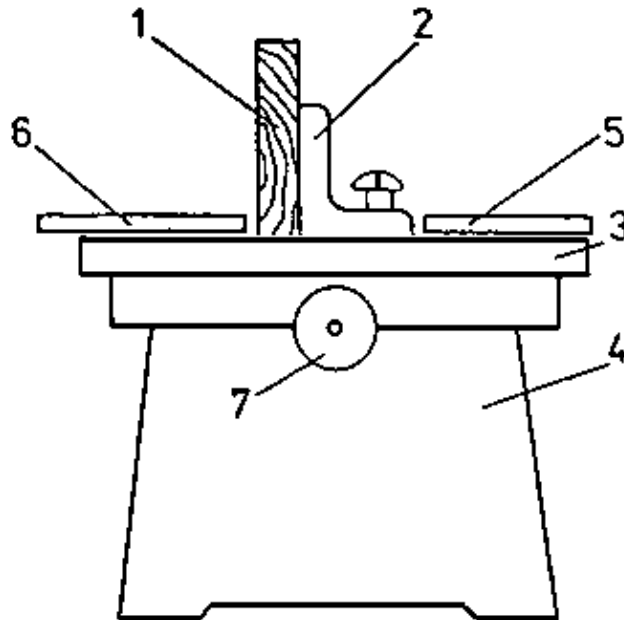

**Figure 2 – Milling of the narrow face**

*1 workpiece, 2 stop bar, 3 feeding table, 4 column, 5 rear cover of the cutter spindle, 6 front cover of the cutter spindle, 7 handwheel for adjustment of table*

## 2. Construction of the Smooth Miller

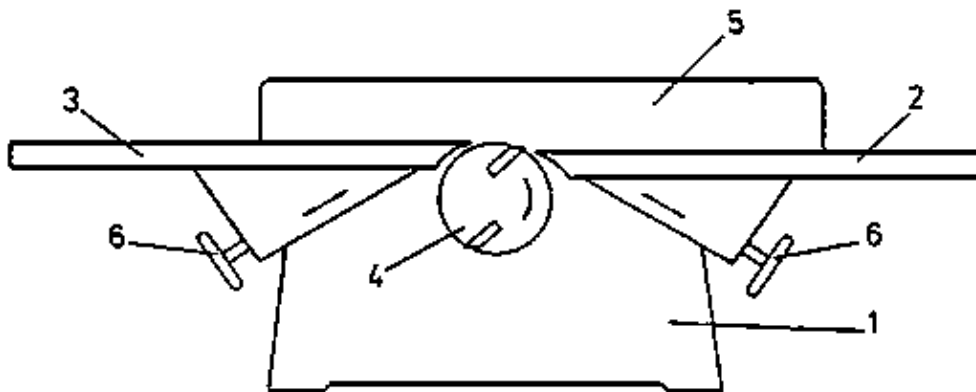

**Figure 3 – Construction of the smooth miller**

*1 column, 2 feeding table, 3 unloading table, 4 cutter spindle, 5 stop bar, 6 handwheel for adjustment of table*

### Column

The column carries both, machine tables and the cutter spindle with the bearing housings. The column accommodates the electromotor.

### Machine tables

The machine tables are vertically adjustable.  
 The depth of cut is set at the feeding table.  
 The feeding table is set to the flying circular height of the cutter.

### Stop bar

The stop bar is horizontally and angularly adjustable. It serves for guidance when milling narrow faces.

### Cutter spindle



In the cutter spindle the cutters are mounted. Their number of revolutions is between 4,000 and 6,000 revolutions per minute. The drive is done by the electromotor with the help of a belt drive.

### Mode of operation of the smooth miller

The cutter spindle is set turning by the electromotor. It planes and finishes the material to be worked by chip removal.

### Safety devices

The part of the cutter spindle which is not necessary for milling is covered by a stationary safety device.

The moveable left part of the safety device releases the necessary working width of the cutter spindle.

Smooth millers may cause heavy accidents. Therefore, pay special attention to the following:

- do not switch on the machine without safety devices
- do not operate the machine without instruction
- make use of the feeding device when machining short workpieces (see Figure 5)
- pay attention to the order on the working place.

## 3. Setting of the Smooth Miller

Setting of the stop bar and the safety device for the necessary working width. Setting of the cutting depth at the feeding table. The cutting depth depends on the necessary chip removal. The chip removal depends, for instance, on the quality of the board and on the relation between rough size and end measure.

## 4. Milling of the Workpieces

The workpieces are to be placed at hand. The workpiece is to put on the feeding table and to push with both hands and under pressure to the unloading table. During pushing the pressure is to shift to the unloading table step by step.

Longer workpieces are to put on with their hollow broad face. First mill both ends until you get a plane surface. Do not put too much pressure on it in order to prevent deflection.

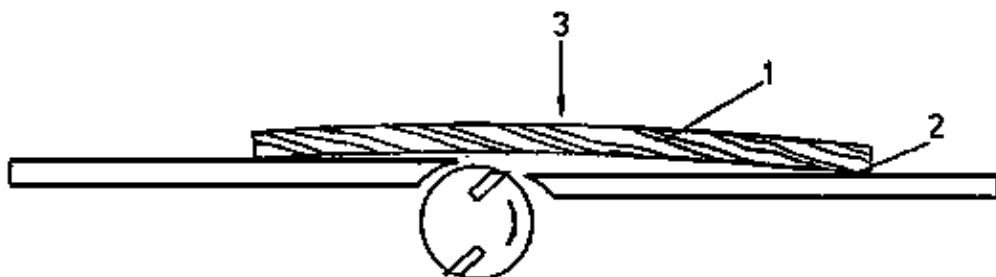
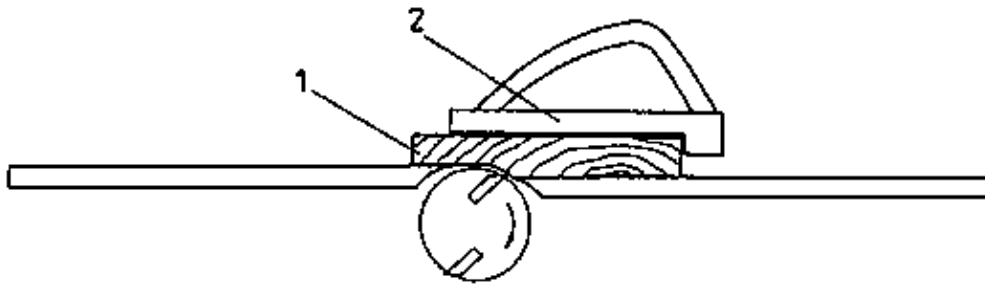

Figure 4 – Milling of high broad faces

*1 workpiece, 2 milled ends of the workpiece, 3 small pressure*

Short workpieces are slid by a feeding device.



**Figure 5 – Milling with feeding device**

*1 workpiece, 2 feeding device*

## 5. Purpose of Milling on the Thicknessing Miller

Milling on the thicknessing miller serves for producing the necessary thickness and width of the workpiece.

## 6. Construction of the Thicknessing Miller

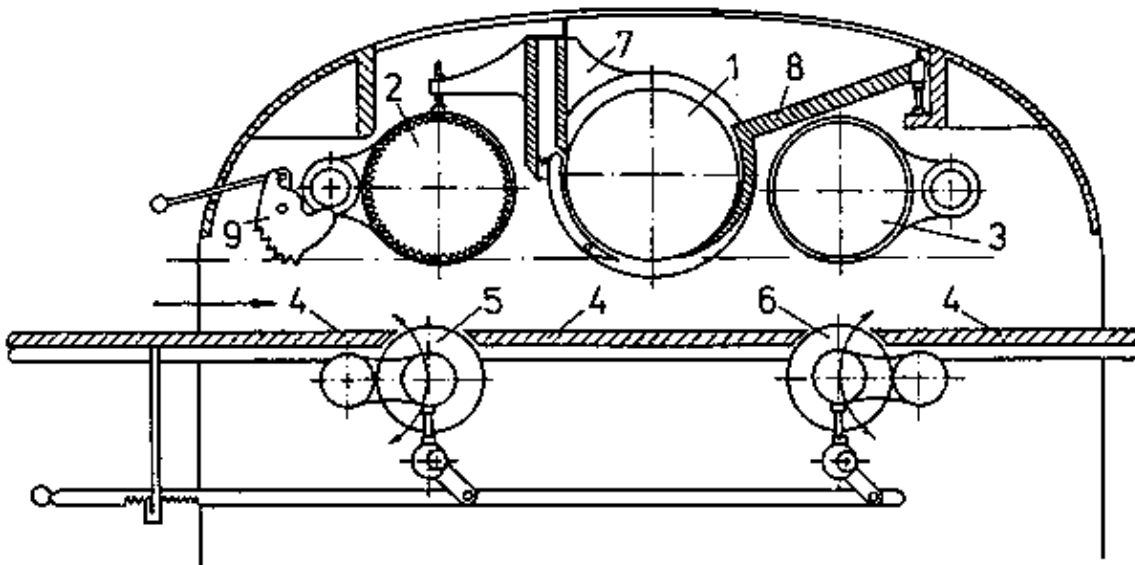

**Figure 6 – Construction of the thicknessing miller**

*1 cutter spindle, 2 feeding roller – corrugated roll, 3 feeding roller, 4 machine table, 5 front sliding roller, 6 rear sliding roller, 7 front pressure beam, 8 rear pressure beam, 9 rebound protection*

### Machine table

The table is vertically adjustable for setting the intended thickness of the workpiece.

Two sliding rollers are inserted in the table to reduce friction between table and workpiece.

### Feeding device

The feeding rollers move the workpiece over the machine table and under the cutter spindle.

The front and rear pressure beam prevent the fluttering of the workpiece when milling.

The rebound protection prevents the workpiece from being thrown out.

### Cutter spindle

In the cutter spindle the cutters are mounted. Their number of revolutions is between 4,000 and 6,000 revolutions per minute. The electromotor drives the cutter spindle and the feeding device.

### **Safety devices**

The closed construction of the thickening miller rules out to contact with the cutter spindle.

Concerning accident prevention it should be observed the following:

- The rebound protection is to check for operability.
- Maximum chip removal is determined by the device for chip thickness limitation (see Figure 6) (depending on the type of the machine).
- Pay attention to the cleanliness of the machine table.
- Workpieces of different thickness should not be inserted at the same time. The thinner workpiece would not be picked up by the draw-in roller (corrugated roll).
- Make use of ear protectors.

## **7. Setting of the Thickening Miller**

The intended working measure is adjustable by vertical adjustment of the machine table. The adjusted measures are readable on a scale.

The machine table should not be fouled by resin residuals; if necessary it is to clean by crude oil or petroleum.

## **8. Milling of the Workpieces**

After setting the milling thickness switch on the machine and slip in the workpieces by hand until they are taken by the feed roller. The feed device does the transport during the milling operation.

The rate of feed is adjustable and is between 5 – 25 m per minute. The lower the rate of feed is chosen the better the quality of the surface will be.

## **9. Tasks**

What is the purpose of milling on the smooth miller?

---

---

---

Which setting is done at the feeding table of the smooth miller?

---

---

---

What for is the stop bar of the smooth miller?

---

---

---

What is the feeding device used for?

---

---

---

Why is to make use of ear protectors?

---

---

Why is the left cover of the cutter spindle adjustable?

---

---

For what purpose is milling on the thickening miller?

---

---

What is the use of the sliding rolls inserted in the machine table?

---

---

What is the use of the both pressure beams?

---

---

What is the rebound protection for?

---

---

Milling a workpiece with lower rate of feed, milling a workpiece with high rate of feed.

---

---

What does become appearant when comparing both workpieces?

---

---

How is the dimensional accuracy to be checked?

---

---

**Working with Presses – Course: Mechanical woodworking techniques.  
Instruction examples for practical vocational training**



# Table of Contents

<b><u>Working with Presses – Course: Mechanical woodworking techniques. Instruction examples for practical vocational training</u></b> .....	1
<u>Preliminary Remarks</u> .....	1
<u>Instruction Example 08.01.: Gluing of Blocks</u> .....	1
<u>Instruction Example 08.02.: Frame Edge Joints</u> .....	4
<u>Instruction Example 08.03.: Board with Reinforcement Strips</u> .....	7
<u>Instruction Example 08.04.: Veneer Glued Pieces of Work</u> .....	10
<u>Instruction Example 08.05.: Simultaneously Clamped Even Pieces of Work</u> .....	12





# **Working with Presses – Course: Mechanical woodworking techniques. Instruction examples for practical vocational training**

**Institut für berufliche Entwicklung e.V.  
Berlin**

Original title:  
Lehrbeispiele für die berufspraktische Ausbildung  
“Arbeiten an Pressen”

Author: Günter Hanisch

First Edition © BE

Institut für berufliche Entwicklung e.V.  
Parkstraße 23  
13187 Berlin

Order-No.: 93–33–3408/2

## **Preliminary Remarks**

The present material includes five selected instruction examples where the working technique of the manufacturing of composition material and veneering can be practiced.

Typical production examples are described. The trainees practice their skills in using a spindle press. In order to ease the preparation and implementation of the exercise for each instruction example the necessary material, machines and tools, measuring and testing devices as well as auxiliaries are mentioned. The basic knowledge which is necessary to prepare and to carry out the instruction examples, are mentioned too.

Together with the working sketches and the added operation schedules the exercises can be carried out independently. For the Instruction Examples 4 and 5 a working sketch was dispensed with.

Exact measures for the pieces of work are not provided with the instruction materials. This can be done additionally for each exercise.

## **Instruction Example 08.01.: Gluing of Blocks**

The manufacturing of thick pieces of work by gluing of blocks will be practised here. This working technique is mainly applied with the manufacturing of pieces of work which are exposed to a high bending stress. But also residual material can be manufactured to yield new pieces of work.

### **Material**

- 4; 6; 8; ... pieces of work of the same width, same thickness and same length.
- Cold glue (the amount is calculated according to the total surface of the joint)

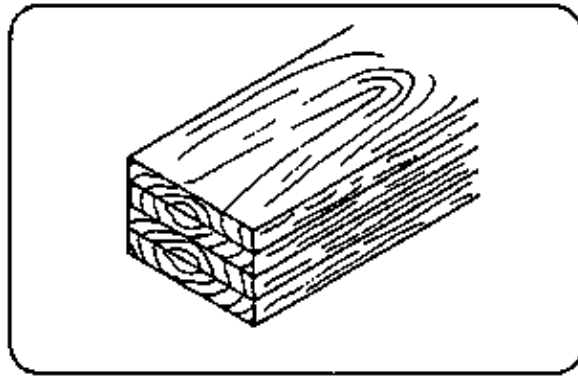

### Tools

Gluing device (brush or putty knife)

### Measuring and testing devices

Folding rule

### Auxiliaries

Pencil, two glue stands, glue cup, a sandwiching sheet

### Necessary basic knowledge

Construction, operation and working with a spindle press (or a veneer press), hints on how to use the glue. Labour safety rules for working with presses.

### Explanations to the working sketch

1 thin free hand line (glued joint)

The measures for each processing task are given additionally (that is why no measures are given in the sketch).

Sequence of operations	Comments
1. Preparing the working material, checking the press for regular technical condition.	Completeness control of the material and the condition of the sandwiching sheet (possible damages, glue residues and dirties).
2. Put the pieces of work together and mark them with triangle marks.	When gluing solid wood glue the right sides of the boards and the left sides together.
3. Place the sandwiching sheet into the press or onto the veneer stands.	Pay attention to sufficient length of the sandwiching sheet!
4. Adjust the spindle height to the necessary measure.	(With veneer stands the height of the pressing sheets should be taken into consideration.)
5. Place a piece of work into the press for testing and find out the best fitting position.	No spindle should press over the length of the piece of work.
6. Calculate the amount of the glue and measure out the necessary amount plus the processing losses.	The laying amount is to be selected according to the absorptive capacity of the material $150 \text{ g} \cdot \text{m}^{-2}$ to $220 \text{ g} \cdot \text{m}^{-2}$ .
7. Using HF–glue measure out the cold hardening compound and mix it with the glue efficiently.	Mix a hardening compound of 2 vol. % (HF–glue = urea–formaldehyde glue).

8. Place the pieces of work blockwise into the glue stands, place the glue and immediately put the pieces of work together to blocks again.

Apply the glue with a brush or a putty knife carefully. The glue must moisten the whole surface and should not be absorbed by the wood completely.

9. Place the pieces of work into the press (or into the veneer stands) and adjust them according to the spindle position.

Add a glue joint only to one of the faces!

All pieces of work must sit above each other in a block!

10. Pull the spindle slowly and alternately.

Excess glue must be pressed out of the joint slowly.

11. Check if all pieces of work are still under pressure and if they are still lying exactly above each-other.

The pieces of work can easily slip out of place! At the joint edges a bit of glue must come out.

12. Clean the gluing devices with water.

13. Clamp out the pieces of work after the necessary setting time.

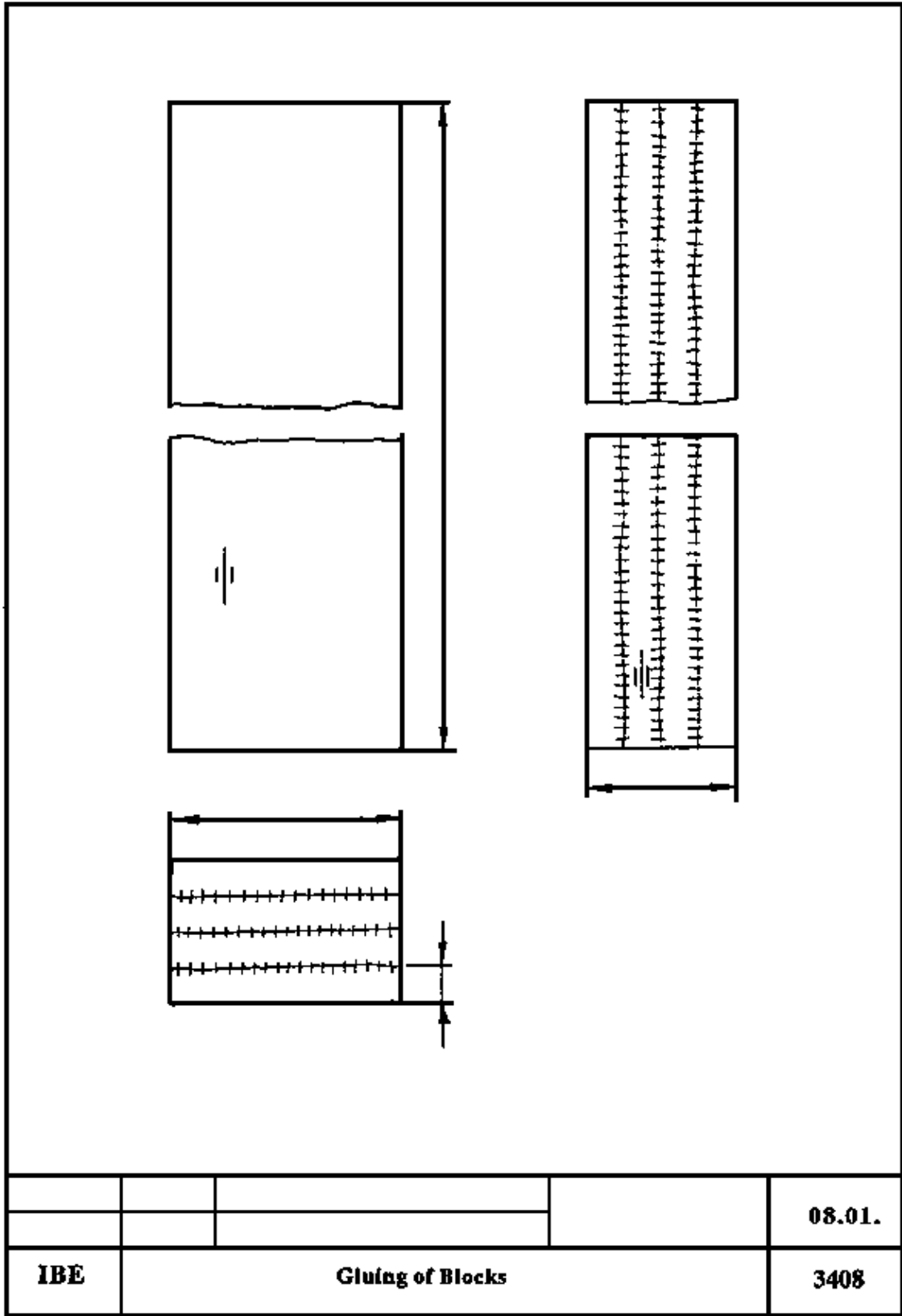

Gluing of Block

**Instruction Example 08.02.: Frame Edge Joints**

The planking of frame work constructions with plates will be exercised here.

Large face structural elements are often manufactured in a frame work construction with one-sided or two-sided planking. Less material expense, less weight and a high stability are the advantages of these

structural elements.

### Material

- Prefabricated frame woods for a complete frame
- Two fibre boards or two plies, measures: frame size + 5 mm allowance in length and width
- Cold glue

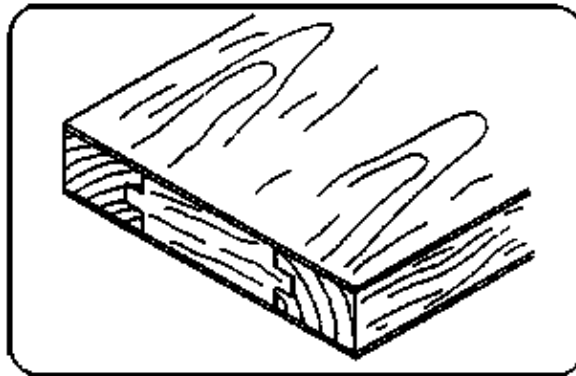

### Tools

Gluing device (brush)

### Auxiliaries

Two glue stands, one sandwiching sheet, a glue cup

### Necessary preparatory work

Manufacturing a frame in an applicable size. Preparing the plates.

### Necessary basic knowledge

Construction, operation and working with a spindle press.

Hints on how to use glue.

Labour safety rules for working with presses.

### Explanations to the working sketch

- 1 Frame edge joining grooved and elastic
  - 2 Frame edge joining bluntly clamped
  - 3 Frame edge joining mitre clamped
- Material thickness 20 mm, planking 3–4 mm

Sequence of operations	Comments
1. Prepare the working materials, check the press for regular technical condition.	Completeness control of the material and the condition of the sandwiching sheet (possible damages, glue residues) place the frame on the glue stands.
2. Adjust the press to the necessary height, place a board into the press for testing.	The spindles should not press over the length of the piece of work.
3. Prepare the glue according to the processing instructions.	Calculate the average necessary amount of glue.
4. Apply the glue on the frame woods. With the frame middle woods apply the glue only thin, place the board exactly on the glued frame, turn the frame with	Apply only 2/3 of the frame wood's width with glue on the outer edge, this process should be carried out by two people.

the board.

5. Apply glue on the opposite side of the frame woods.

6. Place the second board.

Two people are necessary.

7. Place the piece of work into the press and adjust.

Attention!

When placing the piece of work the boards on or under the frame can easily slip out of place, with too high pressing pressure the frame woods can be deformed.

8. Do not pull the spindle too strong.

9. Check the clamped in piece of work.

10. Clean the glue devices with water.

11. Unclamp after the setting time.

### **Possible extensions**

Further frames can be planked.

If necessary the frames can be planked on one side only. When manufacturing a larger number of pieces of work of the same size several pieces of work are clamped above each other into the press. Here you should take into consideration the limited processing time of the glue.

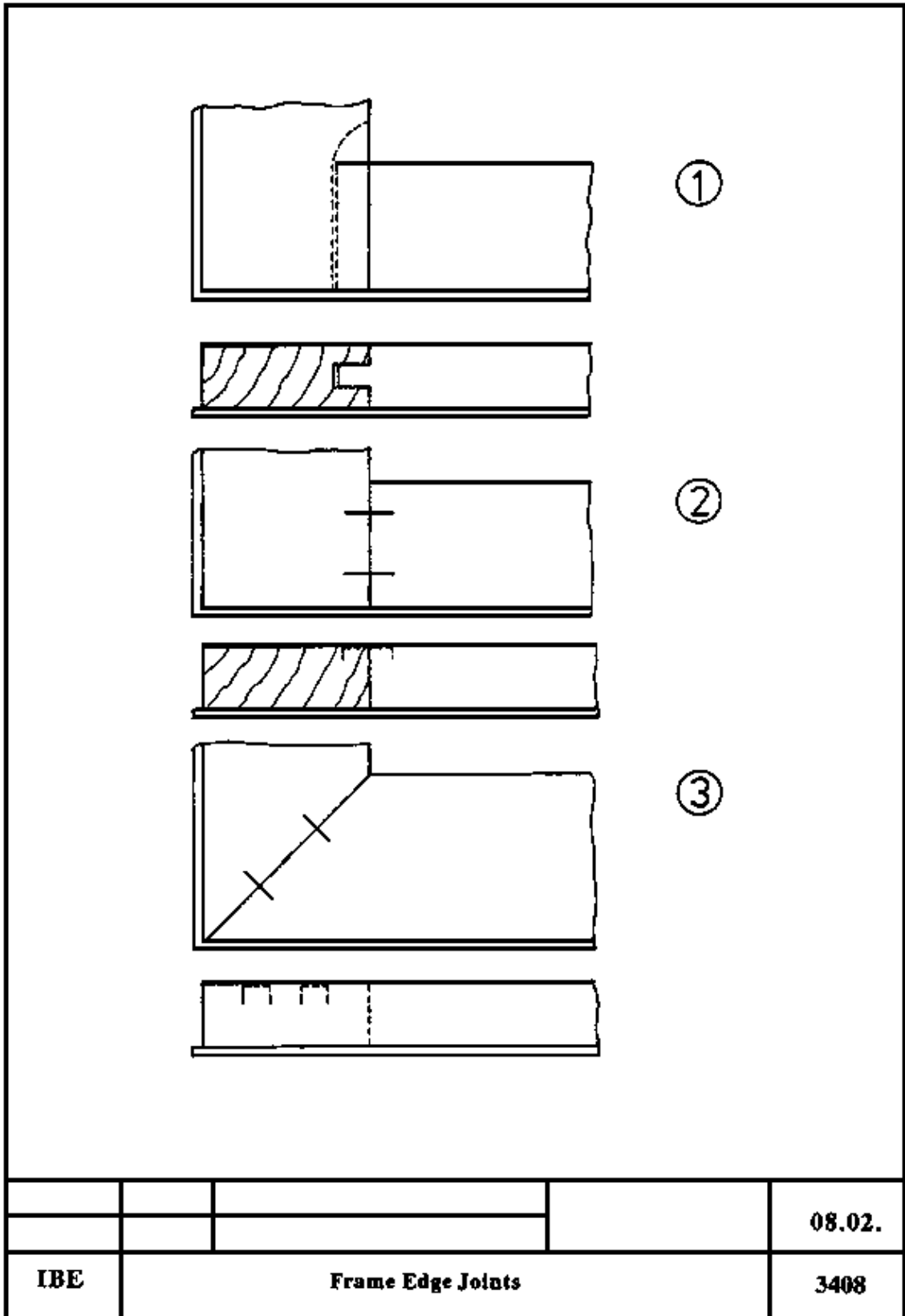

Frame Edge Joints

**Instruction Example 08.03.: Board with Reinforcement Strips**

The gluing of a board reinforcement is practised here.

For optimal reasons it is often necessary to mount thick boards on tables or other pieces of furniture.

By fixing a board reinforcement thick looking pieces of work can be manufactured simply and material saving.

### Material

- One piece of board material, measures according to the task
- Four strips as board reinforcement, measures according to the width and the length of the board material
- Cold glue, eight nails for pinning the reinforcement strips on the board material

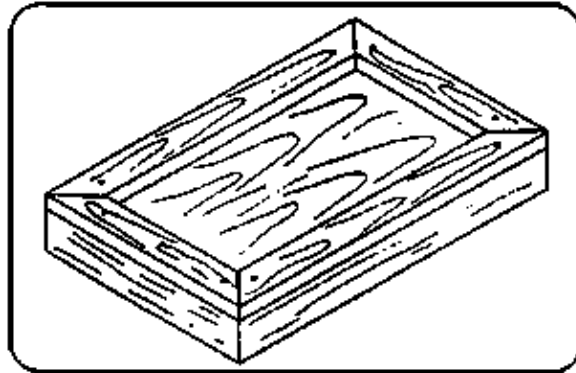

### Tools

Glue brush (thin), hammer (100 g), carpenter's pincers

### Auxiliaries

Two glue stands, one sandwiching sheet, a glue cup, pencil

### Necessary preparatory work

The strips for the board reinforcement are mitre cut according to the measures of the board. Arranged on the opposite side of the board they should form a frame. The external edges of the frame and the board edges must be flush.

### Necessary basic knowledge

Construction, operation and working with a spindle press. Processing instructions for the applied glue. Labour safety rules for working with presses.

### Explanations to the working sketch

No measures are given in the sketch, they should be added according to the working task.

#### Sequence of operations

1. Prepare the working material, check the press for regular technical condition.
2. Adjust the spindle height, place the sandwiching sheet into the press, position the board in the press for testing.
3. Place the plate in the glue stands, mark the width of the reinforcement strips with a pencil on the board's face.
4. Prepare the glue according to the processing instructions.

#### Comments

Completeness control of the material and the condition of the sandwiching sheet.

The face on which the reinforcements are to be glued is on top.



5. Apply the glue on the marked face and then pin the strip with two nails.  
Cut off the overlength of the nails with the carpenter's pincers, strike the nail with a gentle hammer blow flush to the strip's face.

Apply the glue only up to 5 mm before the pencil marking, nails are stroken only 2–3 mm into the board material, they should prevent a slipping of the reinforcement.

6. Glue and pin the remaining reinforcement strips in the same way.

7. Place the board with the reinforcement strips into the press.

8. Tighten the spindle modestly.

Check the density of the joints and the right position of the reinforcement strips.

9. Clean the gluing device with water.

10. Unclamp after the setting time.

### **Possible extensions**

Pressing on further board reinforcements.

Several boards of the same size can be pressed above each other at the same time.

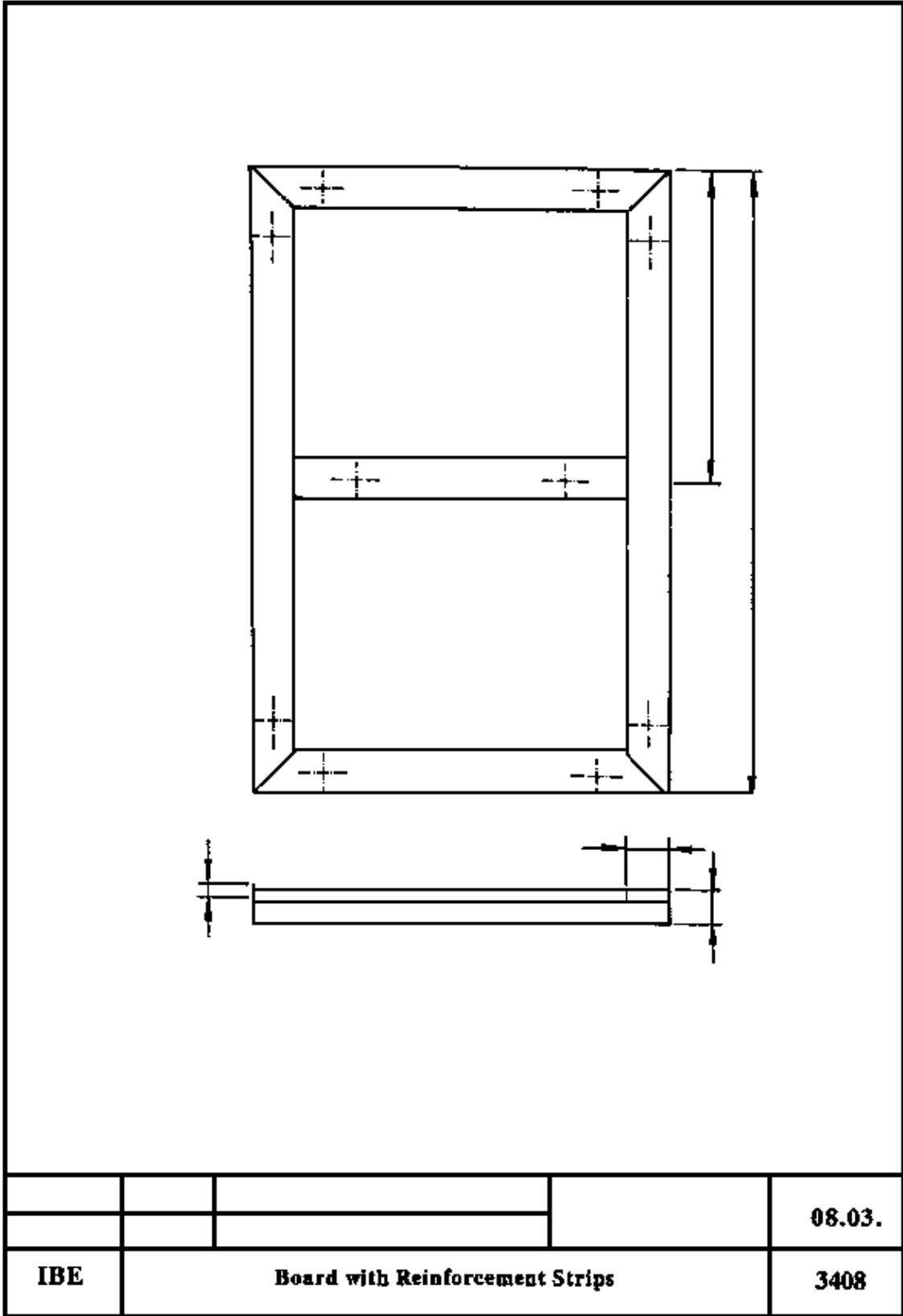

Board with Reinforcement Strips

**Instruction Example 08.04.: Veneer Glued Pieces of Work**

Gluing of smaller pieces of work with veneers is exercised here.

Gluing of wood and wood material with veneer is a technology of material finishing. Along with the optical features of the material the physical features are improved too.

## Material

- At least two pieces of work of the same thickness, length about 300 mm to 800 mm, width about 100 mm
- Pieces of veneer in double amount to the pieces of work, width and length each with 20 mm allowance
- Joint paper, cold or warm glue

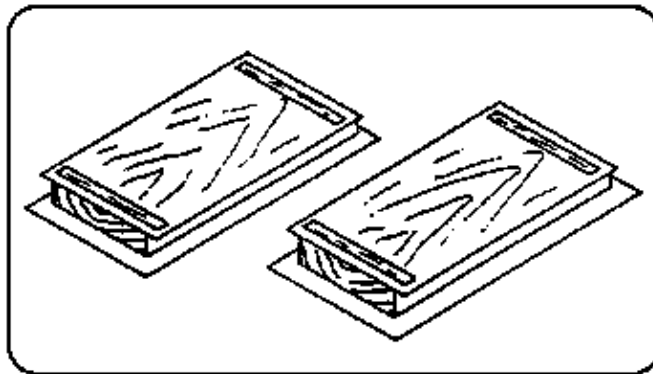

## Tools

Glue brush or glue putty knife

## Auxiliaries

Two glue stands, two sandwiching sheets, a glue cup, stacked woods

## Necessary preparatory work

Shaping the piece of work of solid wood or board material.

Cutting the pieces of veneer.

## Necessary basic knowledge

Construction, operation and working with a spindle press.

Processing instructions for the applied glue.

Labour safety rules for working with presses.

Sequence of operations	Comments
1. Prepare the working material, check the press for regular technical condition.	Completeness control of the material and the condition of the sandwiching sheets.
2. Secure the pieces of veneer against formation of fissures on the upper side during the pressing.	The veneer side with the small surface fissures is glued on. The other side is secured with two joint paper strips.
3. The material to be veneered should be stacked on the glue stands. The pieces of veneer should be sorted, and be placed according to their application – front side and opposite side of the pieces of work.	According to the further application of the pieces of work the most beautiful pieces of veneer with the best quality are glued on the permanently visible front faces. Less or later not visible faces can be glued with veneer of less quality.
4. Adjust the press, place the pieces of work on the press for testing.	Adjust the spindle height. Only those pieces of work should be glued which are placed into the press together.
	Calculate the necessary of glue.

5. Prepare the glue according to the processing instructions.

6. Apply glue on the first face sufficiently and uniform, place the veneer face and turn the piece of work, glue the second face, place the second veneer face, stack the piece of work on a non-processed stack.

7. Place a sandwiching sheet into the press.

8. Distribute the pieces of work in the press on the sheet as assigned.

9. Place the second sheet carefully.

10. Tighten the spindle(s) carefully.

11. Tighten the spindle(s) to the necessary pressing pressure.

12. Clean the gluing devices with water.

13. Unclamp the press after the setting time, stack the pieces of work (for further drying and glue hardening) with stacked woods.

Attention! Too much glue causes glue penetration on the veneer face. No glue should appear on the outer faces of the veneer. This could cause discolourings of the veneer.

When using warm setting glue the sheets should be heated up to 60°C in advance.

Do not push the sheet, otherwise the veneers can slip on the pieces of work.

Tighten them only a little the glue must spread uniform, excess glue should get out on the edges.

Check the pressing material. (Visual control of the distribution of the pieces of work and the getting out excess glue).

Remove the glue residues from the sheets, small pieces of work can be leaned against a wall to dry.

### **Possible extensions**

Gluing of further pieces of work with veneer.

With smaller widths of pieces of work often a gluing of just one face with veneer is necessary.

## **Instruction Example 08.05.: Simultaneously Clamped Even Pieces of Work**

The simultaneous clamping in of several even pieces of work of the same size is exercised here. For the production of furniture and structural elements for interior decoration mostly one or more or less large numbers of sink parts of the same size have to be manufactured. The large spindle lift of a press makes a clamping of pieces of work in several levels possible.

### **Material**

- Shaped board material according to the present working task
- Prepared faces of veneer for further processing, doubled to the number of the board material
- Joint paper, cold or warm glue

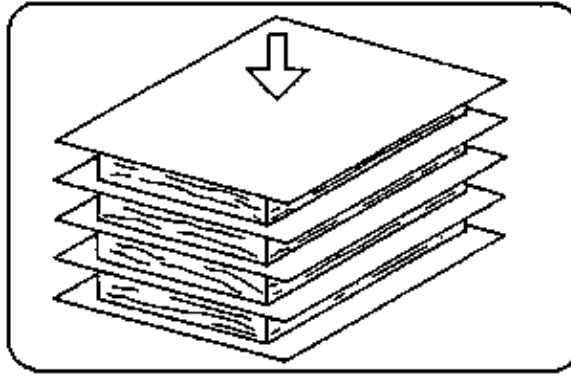

## Tools

Glue brush

## Auxiliaries

4 glue stands, sandwiching sheets (pieces of work to be clamped + 1 = number of sheets), pencil

## Necessary preparatory work

Shaping, joining, placing together and marking the veneer faces. Calculation of the necessary amount of glue.

## Necessary basic knowledge

Construction, operation and working with a spindle press.

Processing instructions for the applied glue.

Labour safety rules for working with presses.

Sequence of operations	Comments
1. Mark the pieces of work with triangle marks and accordingly letter the veneer faces. Place the pieces of work in right order on two glue stands.	Do not mark with a copying pencil or with water soluble colour pencils. The dye-stuff penetrates through the veneers.
2. Put the prepared veneer faces in the same order as the boards and place them to be at hand.	Fissures which are caused by storage or handling on the front side are glued over immediately with joint paper.
3. Check the press and the sheets for their use.	When using warm setting glue the sheets are heated in advance.
4. Adjust the spindle height and position one piece of work in the press for testing.	
5. Prepare the needed amount of glue according to the processing instructions.	
6. Apply the glue with a putty knife on the first face, place the veneer and turn the piece of work immediately, apply glue on the second face and place the veneer, place the piece of work on both the glue stands.	The process has to be carried on till the clamping into the press without stopping, the glue should not set or dry before that.
7. Handle the next piece of work as said in 6. and so on with all pieces of work.	Do not apply glue on the outer faces of the veneer.
8. Pull out the press table of the press, place the sheet and then piece of work.	

9. Place the sheet on the piece of work, place the second piece of work, place the next sheet and so on until all pieces of work are placed and covered with a sheet.

The pieces of work should be placed exactly above each other, no spindle should press over the length of a piece of work.

10. Push the press table carefully to the stop into the press.

With a hard stop of the table the pieces of work can change their position.

11. Lower the spindle slowly and carefully and then pull softly. After a break of 0.5 min. pull again softly and again wait for 0.5 min.

The veneer faces start to glide on the glue surface with light pressure! When the excess glue has been pressed out of the edges the veneer cannot glide any longer.

12. Pull the spindle to maximum press pressure.

13. Clean the gluing devices with water.

14. After the setting time of the glue the pieces of work can be unclamped.

Pay attention when handling the unclamped pieces of work. The glue has not reached yet its full setting power and damages are possible.

15. Stack the unclamped material for drying and hardening on stacked woods on stands.

16. Clean the sheets from glue residues.

### **Possible extensions**

The veneer faces can be replaced by layer plies or artificial leather faces. When using artificial leather a smooth piece of cloth is placed between the leather and the sheet, and the spindle is tightened only a little bit.

**Working with Presses – Course: Mechanical woodworking  
techniques. Trainees' handbook of lessons**





# Table of Contents

<b><u>Working with Presses – Course: Mechanical woodworking techniques.Trainees' handbook of lessons.</u></b> .....	<b>1</b>
<u>1. The Purpose of Working with a Press</u> .....	1
<u>2. The Construction of a Press</u> .....	2
<u>3. Technological Application of the Press</u> .....	4
<u>3.1. Gluing of Pieces of Work</u> .....	4
<u>3.2. Finishing of Even Pieces of Work by Veneering</u> .....	6
<u>4. Labour Safety with the Spindle Presses</u> .....	12



# Working with Presses – Course: Mechanical woodworking techniques. Trainees' handbook of lessons

Institut für berufliche Entwicklung e.V.  
Berlin

Original title:  
Arbeitsmaterial für den Lernenden  
"Arbeiten an Pressen"

Author: Günter Hanisch

First Edition © IBE

Institut für berufliche Entwicklung e.V.  
Parkstraße 23  
13187 Berlin

Order-No.: 93-35-3408/2

## 1. The Purpose of Working with a Press

The working technique of pressing serves to produce various timber materials by gluing the separate parts of the material to compound material.

The working technique of pressing in its basic form is applied when manufacturing ply material in veneer technology and producing thick pieces of work from thin basic material. In order to manufacture high quality furniture and other interior decoration additional technical and technological measures have to be considered with this working technique. Veneer technology is one possibility of improving materials. Here you change the technical and visual features of the pieces of work.

To secure a high stability of the glued joint a forced feed between 0.1 MPa and 1.3 MPa is necessary. The manufacturing of large face pieces of work requires a great total pressing power which can be yielded only with special presses.

Different types of presses are applied with wood working:

### *Mechanical presses*

The forced feed is produced by spindles (a spindle press). This press is mainly applied with the manufacturing of one-off parts furniture and structural elements. Mainly width face gluings are carried out with this press.

### *Pneumatic presses*

The forced feed is produced with air pressure by a compressor. These presses are mainly produced as narrow face presses, frame presses or corpus presses.

### *Hydraulic presses*

The forced feed is produced by oil pressure. With these presses a very high forced feed can be achieved. They are applied with the manufacturing of furniture parts in mass production by width face gluing.

In the present material the construction and technological application of a spindle press is described. With a spindle press there can be manufactured solid wood sheets, composition plates, frame elements and ply-wood. Wide face material can be glued up with veneer or similar materials.

## 2. The Construction of a Press

The stand of the press serves as the power input when pressing. All bearing elements of the stand are made of sectional steel and are screwed home.

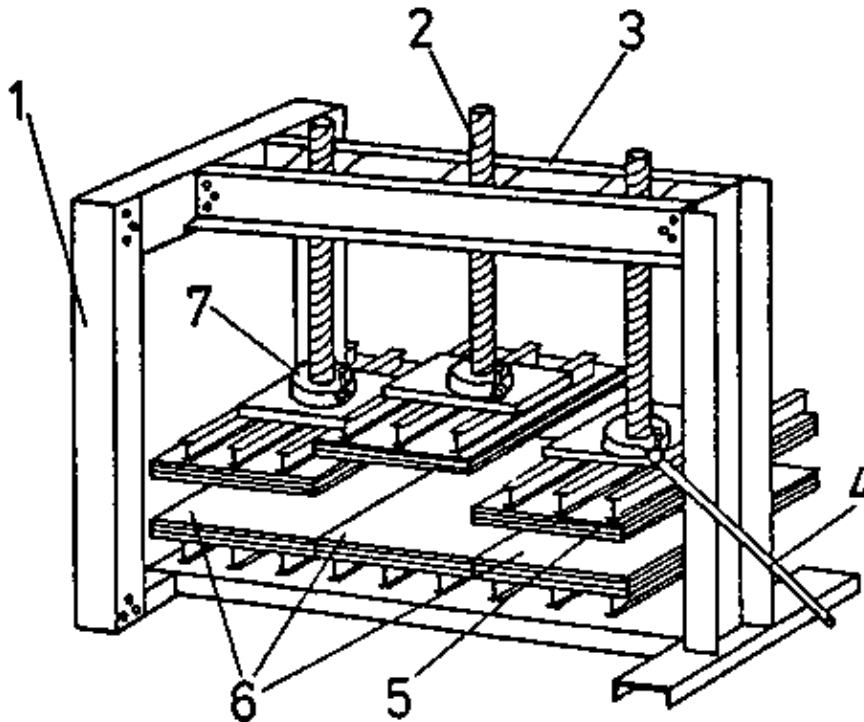

**Figure 1** – Spindle press

*1 press stand, 2 pressure spindle, 3 cross beam, 4 clamp lever, 5 pressing plate, 6 pressing table, 7 spindle controlling unit*

The total pressing surface of the machine is divided into three separate pressing tables with their respective pressing plates and spindles. Depending on the size of the piece of work one, two or three spindles are applied. In order to provide the press easier with material the pressing tables can be pulled out on sliding rollers out of the press stand.

To produce the forced feed the press spindle is used. It ends with the narrow thread in the spindle screw. The female screw is made of grey cast iron and is screwed beneath the cross beams of the press stand. The lower end of the spindle sits in the pressure shoe with a pivot.

The pressure distribution ensues through the spindle pivot, the pressure plate, two crossed grills made of sectional steel on to the pressing plate and then on to the piece of work.

The pressing plate is made of wood and its underface is slightly domed on all sides. The forced feed should first operate in the centre of the piece of work in order to press out excess glue at the edges.

The different ructions – open the presses – or – close the presses – are adjusted by means of a tongue on the spindle controller (s. Figure 2 and 3).

To tighten the press spindle a 1500 mm long lever is used. The tightening is carried out depending on the size of the occupied face of the table by one or two people (with man power). The lever should not be prolonged by using a tube. Otherwise the pressure power achieved in this way can damage the mechanically loaded parts of the press!

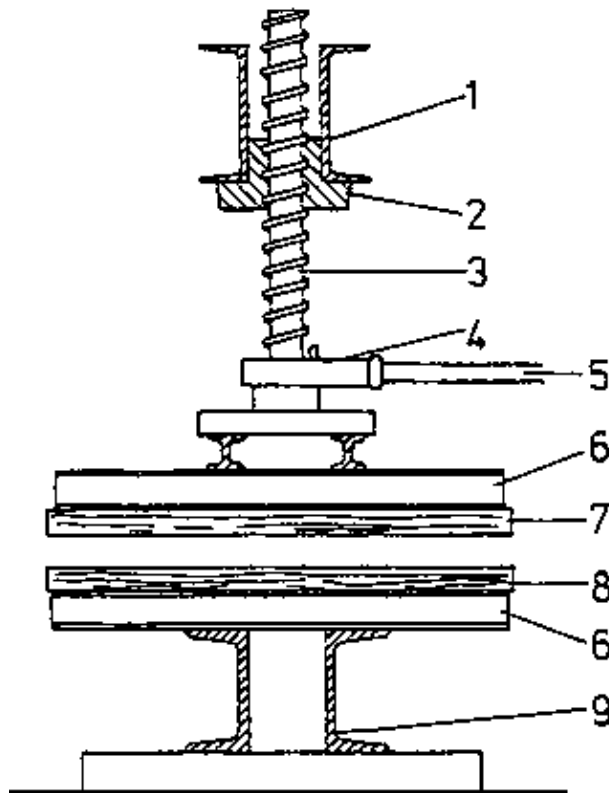

**Figure 2 – Press (cut-away model)**

*1 cross beam, 2 spindle screw, 3 pressure spindle, 4 lever guide, 5 clamp lever, 6 grill made of sectional steel, 7 pressing plate, 8 pressing table, 9 press stand*

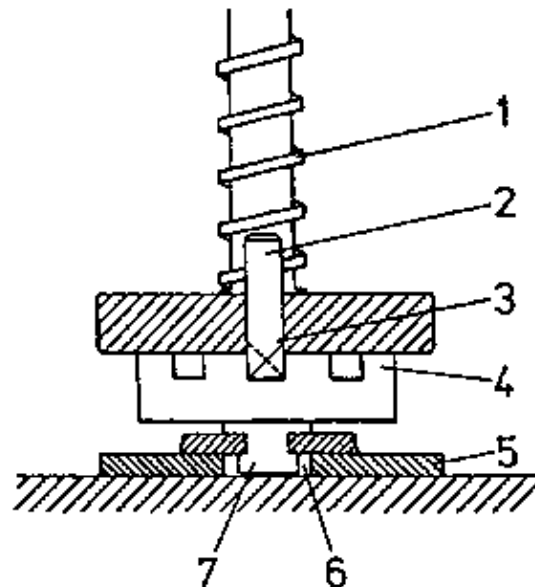

**Figure 3 – Spindle controlling unit**

*1 pressure spindle, 2 notch pawl, 3 / close the press; \ open the press, 4 notch wheel, 5 pressure bearing, 6 grease chamber, 7 spindle mortise tenon*

The press is provided with a set of intermediate layers made of 2 mm to 3 mm aluminium. They are placed between the pressing table and the piece of work and between the piece of work and the pressing plate, as well as between separate pieces of work. Maintenance and service of the press is easy. It includes a regular lubrication of the spindle and the spindle bearing as well as to keep the pressing surfaces and the sheets clean.

### 3. Technological Application of the Press

#### 3.1. Gluing of Pieces of Work

The gluing in sheets of different solid wood thicknesses is especially necessary in frame furniture production. If skillfully manufactured the produced pieces of work are of an especially high stability. The shrinkage and swelling behaviour can be adjusted to the corresponding purpose of application.

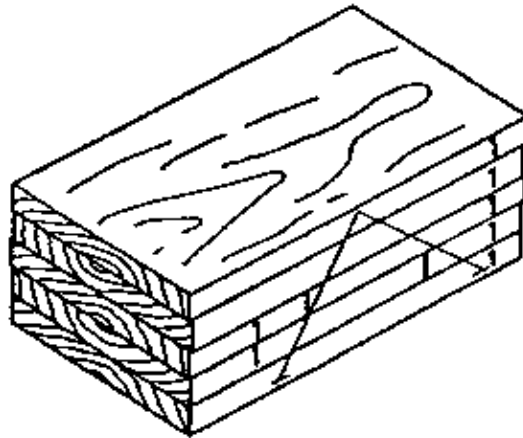

**Figure 4** – Block of single pieces of work with triangle marking and numbering

When the glued blocks are put together the shrinkage and swelling behaviour of the separate pieces of work should be taken into consideration. If only two pieces of work are placed together their left faces are put one on to the other. These faces become hollow when losing moisture. A splitting up of the joint edges cannot occur with the glued piece of work. With more than two pieces of work always the left sides and the right sides are joined.

In the middle sheets you may also place shorter pieces of work with a cross joint. Because during the bending stress of the ready-made pieces of work mainly the edge zones are subjected to stress a cross joint has little effect on the stability.

To manufacture a glued block also other timber materials can be used as basic material.

The used glue should have a high viscosity but it should not be soaked up by the material or dry out when the glue is put on and the piece of work being fastened in the press. The features of the various glues are different.

Dispersion glues do not need a hardener for binding. With little extraction of water these glues lose their viscosity quickly. When placing the forced feed the glue cannot spread uniformly in the joint which results in failure gluings. Because of these features dispersion glue should be applied very thin and in large amounts.

The period of time between putting the glue on and clamping the piece of work should be very short and that is why only a few pieces of work should be clamped together. When the forced feed is starting the glue must be still liquid!

The application of glue on urea-formaldehyde basis allows the clamping of a larger amount of pieces of work because this glue alters its viscosity only little after the glue has been put on. But it is subject to dry quickly.

That is why after the glue had been put on the joint should be closed immediately by joining both the joint faces. Urea-formaldehyde glues require a special hardener for binding. By mixing it with a 2 % to 3 % binding agent it is made ready to use. The processing period starting now should not be exceeded. The processing period depends on the type of the binding agent and on the room temperature. To avoid losses of time the working process prior to the clamping of the piece of work must be well prepared.

Before using the glue for the first time you should study the processing instructions carefully.

The stability of a glued joint is increased if the glue layer between the pieces of work is thin. That is why the joint faces should be clean and even. If too much binding agent is added to the glue its solidity is reduced!

The pieces of work should be arranged on the pressing table always symmetrically to the press spindle.

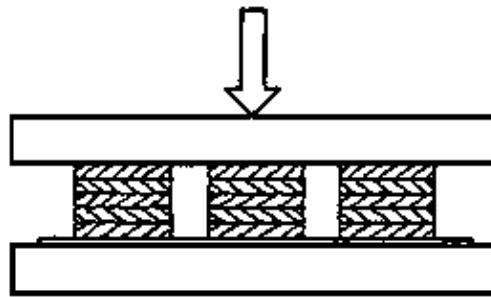

**Figure 5** – Example for the distribution of the pieces of work on the pressing table

Why must always the left sides of the pieces of work form a joint when two wooden pieces are glued to a block?

---

---

---

Why can the pieces of work in the middle be short and lengthwise arranged when gluing a block?

---

---

---

Why should only a few pieces of work be pressed together at the same time when applying dispersion glue?

---

---

---

Wall-to-wall elements or inside doors are often manufactured in lightweight construction. Here thin plates are glued on to a wooden frame. With this kind of planking the stability of the frame element is increased many times over. The edge joint of the frame is subject to stress only during pressing. That is why a simple and saving joining can be applied.

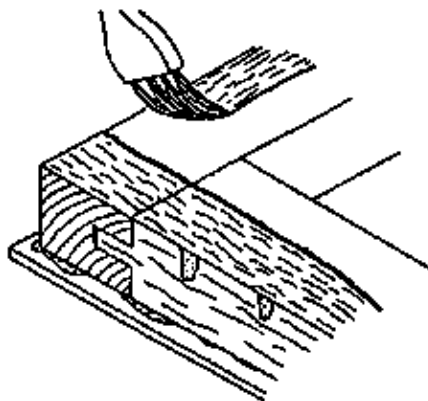

**Figure 6** – Putting glue on frame woods

The glue should not be put up to the inner edge of the frame. The excess glue emerging from the frame edges features a great shrinkage measure when drying out. The resulting forces would damage the plates inwards the frame. Then the outlines of the frame woods would be visible on the outside faces of the plates.

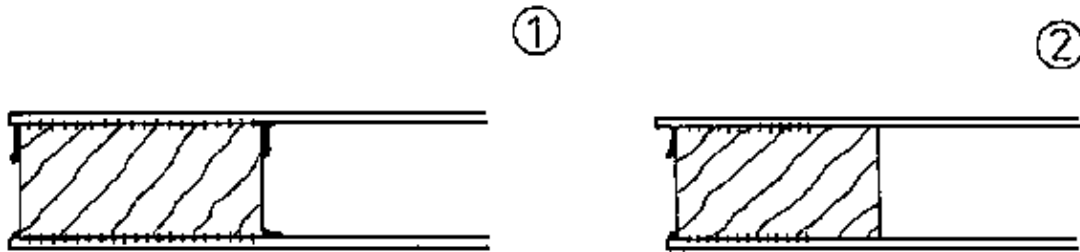

Figure 7 – Gluing

- (1) Gluing the full frame width, marks on the board's face
- (2) Right gluing, no marks

### 3.2. Finishing of Even Pieces of Work by Veneering

#### Application of this technique

By the subject “veneering” we understand the gluing of a thin wooden layer on to a basic material. Veneering first of all is the visual forming of the surface concerned. Symmetric pictures resulting from the growth conditioned graining of the timber can be manufactured by placing several thin wooden sheets (called veneer) together. High-quality varieties of timber can be glued on timbers of less quality in a thin and saving layer.

By an purposeful processing of the veneers the mechanical features of the pieces of work can be improved.

With the manufacturing of composition plates, veneer plates and layer woods this method of application is put into practise.

#### The manufacturing of veneer faces

The veneers are sold in packages with a maximum number of sheets of 32 (the number of sheets can always be divided by four) and a length from 0.8 m to 4 m. For processing veneer faces of the desired visual features and the required sizes are manufactured from the single veneer sheets.

When selecting the veneer and blanking it the following basic rule should be considered:

- The sequence of the veneer sheets in the package should not be altered. Otherwise the texture pictures will not fit.
- Faulty veneer parts (discolourings, bothering branches, large fissures, ...) should not or later be used for not visible faces.
- The best grainings of the veneer sheets are selected for the exterior faces which are visible later on.
- The number of the required veneer sheets should be determined before blanking.

*Examples how to calculate the number of sheets and the blank measures for teh veneer face to be placed together:*

A piece of work with a width of 550 mm and a length of 1200 mm shall be veneered.

How many veneer sheets do you need?

Which size should the veneer sheets be cut to?

The given width of the veneer sheets in the package is 320 mm.

To cover a veneer face of 550 mm two widths of veneer sheets are necessary. For the front and the opposite sides of the piece of work

4 veneer sheets are needed.



The blank length results from the length of the piece of work + an allowance of 50 mm for further processing in the press

$$= 1200 \text{ mm} + 50 \text{ mm} = 1250 \text{ mm.}$$

The veneer sheets are cut to a length of

1250 mm.

The width of the blank results from the width of the piece of work + an allowance of 30 mm for further processing in the press + an allowance of 10 mm for trimming the joint edges and divided by 2 (number of sheets per face).

550 mm

+ 30 mm

+ 10 mm

$$590 \text{ mm} : 2 = \underline{295 \text{ mm}}$$

The veneer sheets are cut to a width of 295 mm.

One side of the veneer sheets features small fissures with the grain. These result from the manufacturing of the veneers. The depth of the fissures depends on the type of the wood. These fissures become visible when the veneer sheet is carefully bend across the grain.



**Figure 8** – Principle of veneer production

Veneers with very deep surface fissures should be glued with the side of the fissures, if possible. These fissures can result in surface damages of the varnished face later on. Such veneers are therefore less good for the arrangement of wide veneer faces because here the shaken face appears reciprocally on the front and on the opposite sides. For inside faces of furniture and later not visible faces this fact is of no significance.

After blanking follows the arrangement of the veneer sheets to veneer faces. Thereby the order of the veneer sheets should be followed, every other sheet is turned. The arranged face has to be marked with triangles and the number of the piece of work in order not to be mixed up.

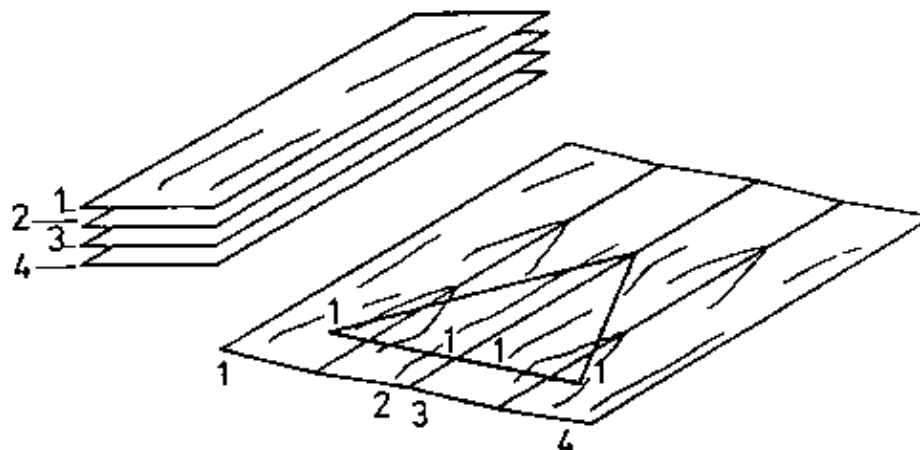

**Figure 9** – Arrangement of a wide veneer face with separate veneer sheets (1, 2, 3, 4)

After that the veneer sheets are arranged in the original order again. And now they are clamped with two boards on a suitable longer board. The veneers should be arranged flush with the edges and should project the boards by 5 mm. The edge should be trimmed with a jack-plane in straight line.

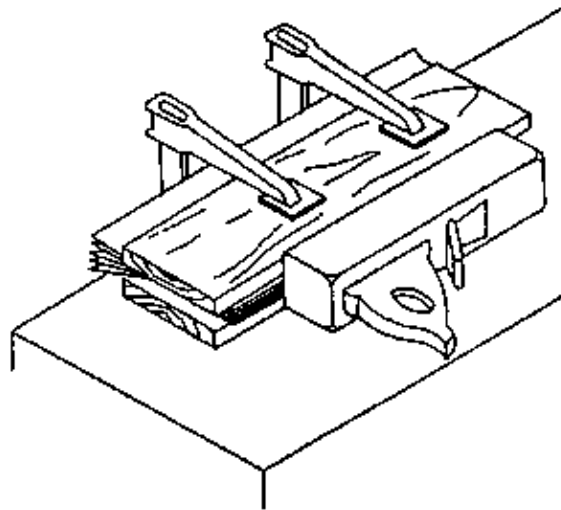
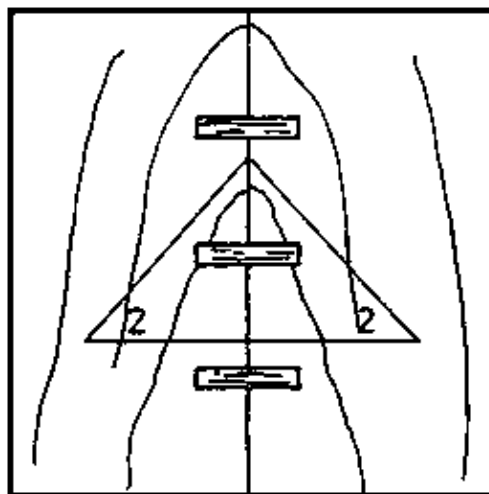

Figure 10

After this job the veneer faces are placed together separately. The joint density can be checked by pressing the two veneer sheets together at the joint edges. Now the joint should be invisible.

On the marked side of the veneer the joint is now secured by using joint paper. The graining of both the veneer sheets should now diverge in the joint exactly. Short pieces of joint paper are now glued at a distance of 10 mm starting from the middle of the joint.



①

Figure 11 (1)

After that a long stripe of joint paper is glued over the total length of the joint. This stripe avoids the overlapping of the joint parts and the penetration of glue when pressing.

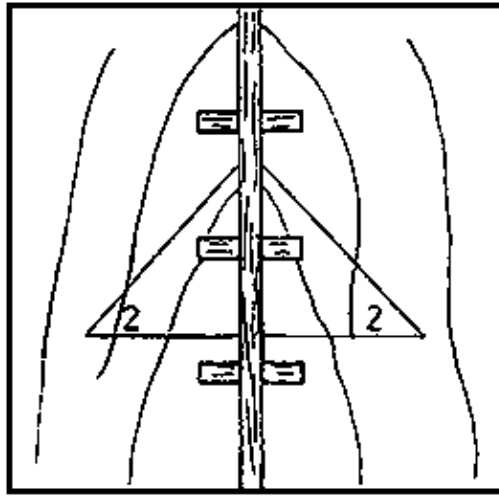

②

Figure 11 (2)

Another two stripes of joint paper are glued near the upper and the lower edges of the veneer face. These should avoid the formation of fissures at the edges.

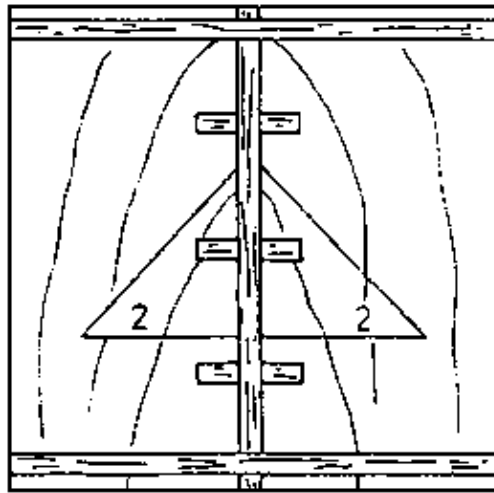

③

Figure 11 (3)

The faces prepared in this way are stored covered until further processing. Too much drying out of the wood would make the faces rough and brittle.

Why should veneers with large surface cracks be glued with the shaken side on to the basic piece of work, if possible?

---



---



---

### The technological process of veneering

Pressing should be carried out without disturbances and losses of time. The time limit is determined by the processing time of the applied glue. This period is the basis for the determination of the number of pieces of work to be manufactured in one process.

The working processes should be prepared carefully. Here you should pay attention to that there is enough room to move in the area of the press and in the area of the glue stands. All material should be at hand and be arranged in the right order. Before you start the necessary number of sandwiching sheets has to be cleaned. When using warm binding glues the sheets should be heated up to 60°C. The press spindles are adjusted to a sufficient height so that the pieces of work and the sandwiching sheets can be placed into the press without problems.

After all these preparations are done the glue can be made ready for processing. The processing instructions

of the glue producer should be considered by all means. Urea–Formaldehyd glues are mixed with a binding agent. Too much mixed glue cannot be stored for other jobs. After a certain period of time it hardens out. That is why the necessary amount of glue should be worked and measured out in advance.

*Calculation examples:*

Four pieces of work with the sizes of 1200 mm length and 550 mm width shall be veneered.

How much glue do you need for an average coating of  $200 \text{ g} \cdot \text{m}^{-2}$ ?

$$\frac{1.2 \cdot 0.55 \cdot 4 \cdot 2 \cdot 200 \text{g}}{\text{m}^2} = 1056 \text{g}$$

1056 g (calculated quantity)

+ 105 g (10 % allowance for processing loss)

1161 g

You have to mix 1200 g of glue.

With larger faces you should put the glue on with a putty knife. The size of the filed in teeth is important for the applied amount of glue. For veneering jobs only the minimum amount of glue should be used. Excess glue can penetrate through the veneer's thickness under pressing. The result is glue penetration. The glue will be visible later on the piece of work.

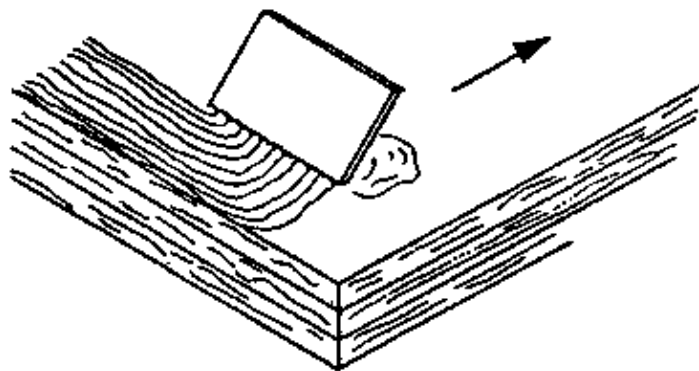

**Figure 12** – Putting on glue with a putty knife

The glue coated face should immediately be covered with a veneer face. Thus you avoid the glue to loose too much moisture.

To turn the pieces of work and to place them into the press two people are needed. Pieces of work and sandwiching sheets are placed into the press layerwise.

First the press is fastened with little pressure. The excess glue needs a certain time to emerge from the middle of the joint to the edges.

When fastening one spindle the neighbouring spindles become loose because of the deformation of the press stand. These have to clamped by all means!

When loosening one spindle the pressure on the neighbouring spindles is increased if they were under pressure. That is why all spindles have to be loosened simultaneously.

### **Possible reasons for faulty gluings**

The most often fault occuring with veneering works is *glue penetration*. With large porous veneer woods it cannot be avoided. The penetration of glue can be reduced by a saving, but sufficient application of glue. With the help of binding agents (pea flour, soya flour or other swelling agents) the glue can be thickened. In doing so, the ability of penetration of the glue is reduced. When manufacturing dark veneer woods the glue should be made suitable to the colour of the wood by adding suitable dyes.

Bleb shaped *faulty gluings* can be of different reasons:

- at the parts concerned there was put no or too little glue
- there have been oil, fat, dust, water or other pollutions on the face of the piece of work or the veneer's
- the face is uneven, at the place concerned pressure was missing
- before starting with the forced feed the glue did already bind.

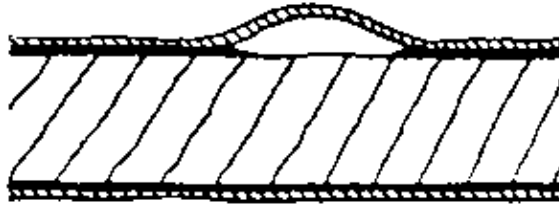

Figure 13

*Glue bulges* are rolling glue piles under the veneer face.

Reasons:

- too much glue, the press has been tightened too fast
- the face was hollow, the press could not press
- you have used unequal veneer thicknesses



Figure 14

*Overlapping* are veneers lying over each other.

Reasons:

- the joint was not trimmed in a straight line
- the veneer face had been damaged when placing into the press (here open fissures in the veneer can occur)
- you applied too rolling veneer which had not be fastened even enough when being trimmed

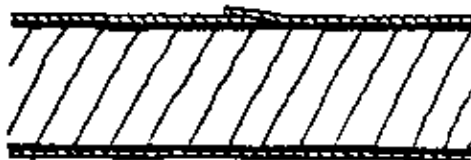

Figure 15

*Foreign substances* on or under the veneer face.

Reasons:

- unclean glue or putty knife
- glue remains on the sandwiching sheet



Figure 16

#### 4. Labour Safety with the Spindle Presses

When operating the spindle press it carries out only slow motions. That is why there are no accident hazards resulting from the driving parts of the machine.

However faulty handling of the clamp lever and the spindle controlling unit can lead to accidents.

The press is closed and opened with strong man power. If the clamping strength of the clamp lever stops suddenly the operating person comes to fall. On the press stand or other objects you can be injured seriously. That is why you always shall pay attention to the right sitting of the clamp lever in the lever lead. Before you exert pressure you have to check that the notch pawl has locked in the notch wheel (visual inspection).

Hardened urea–formaldehyde glue forms very sharp edges. There is a hazard of getting injured when unclamping, so please do it carefully. It is not permitted to use an additional clamp lever prolongation. Otherwise the press can be damaged because of overloading.

**Ripping and Mortising – Course: Manual woodworking techniques.  
Instruction examples for practical vocational training**





# Table of Contents

<b><u>Ripping and Mortising – Course: Manual woodworking techniques. Instruction examples for practical vocational training</u></b> .....	<b>1</b>
<u>Preliminary Remarks</u> .....	1
<u>Instruction Example 6.1.: Recess</u> .....	1
<u>Instruction Example 6.2.: Slot Hole and Dovetail Hole</u> .....	3
<u>Instruction Example 6.3.: Mortise</u> .....	7



# **Ripping and Mortising – Course: Manual woodworking techniques. Instruction examples for practical vocational training**

**Institut für berufliche Entwicklung e.V.  
Berlin**

Original title:  
Lehrbeispiele für die berufspraktische Ausbildung  
“Stemmen und Stechen”

Author: Rolf Jakoby

First edition © IBE

Institut für berufliche Entwicklung e.V.  
Parkstraße 23  
13187 Berlin

Order No.: 93–33–3306/2

## **Preliminary Remarks**

The present material includes 3 selected instruction examples by means of which the trainee is able to acquire fundamental knowledge and skills in the working techniques of mortising and ripping. These training examples are arranged so that the trainee can learn the handling and correct application of the tools in performing different mortising and ripping operations for manufacturing of wood joints.

This work also includes sharpening of the mortising and ripping tools if the tools' condition should make this necessary.

Knowledge and skills already acquired for sharpening of plane irons from the training course of “Planing” should be applied for this purpose.

For each instruction example, the necessary materials, tools, measuring and testing means and auxiliary accessories are specified to facilitate the preparation and execution of the work.

Furthermore, the previous knowledge is given that is required to work the workpieces and should be incorporated into the exercises for recapitulation.

The sequence of operations specified for each instruction example includes working steps leading to the acquisition of the working technique and the manufacture of the connecting element for the relevant workpiece.

Technical particularities and the achievement of quality features are specifically mentioned.

A working drawing is attached to each instruction example showing the required shape and the dimensions of the practising piece and of the connecting element to be mortised.

In case of a further application of the connecting elements and practising pieces for useful products the required dimensions are decided at the instructor's discretion.

## **Instruction Example 6.1.: Recess**

[...]

**Sequence of operations**

**Comments**

- |   |  |
|---|--|
| 1. Check and prepare the tools, adjust the carpenter's bench.   | Check sharpness of the mortising and ripping tools; pay attention to store the tools properly and safely!  |
| 2. Scribe the recess on the workpiece according to the given dimensions.  | For scribing the depth use a marking gauge.  |
| 3. Clamp the workpiece in the carpenter's bench.  | The scribed width face is on top.  |
| 4. Give a cut with the saw along the measure lines up to the scribed working depth.   |  |
| 5. Chisel out wood chips<br><br>– by driving in the firmer chisel from the centre of the recess with the grain at an acute angle to the wide face,<br><br>– splitting off the wood chips by bending the firmer chisel backwards and down. | Tilt the cutting edge of the blade of the firmer chisel slightly upward; recess the entire width and depth of the workpiece in sections; pay attention to the working depth, cut the thin wood chips last. |
| 6. Work in the opposite direction (see operation No. 5).  |  |
| 7. Flatten and smooth the prechiselled surface; ensure the exact dimensional stability by re-working with the ripping chisel diagonally and across the grain.   | The cutting edge of the ripping chisel blade should be pointed at the working face of the workpiece; guide the ripping chisel just up to the centre of the surface to avoid fraying of wood fibres.        |
| 8. Check the dimensional stability and the flatness of the chiselled surface.   | Half of the scribed line should be visible; the surface must not be splintered; lay a straightedge across and diagonally on the surface and compare.   |
| 9. If necessary, sharpen the mortising and ripping tools.   |  |

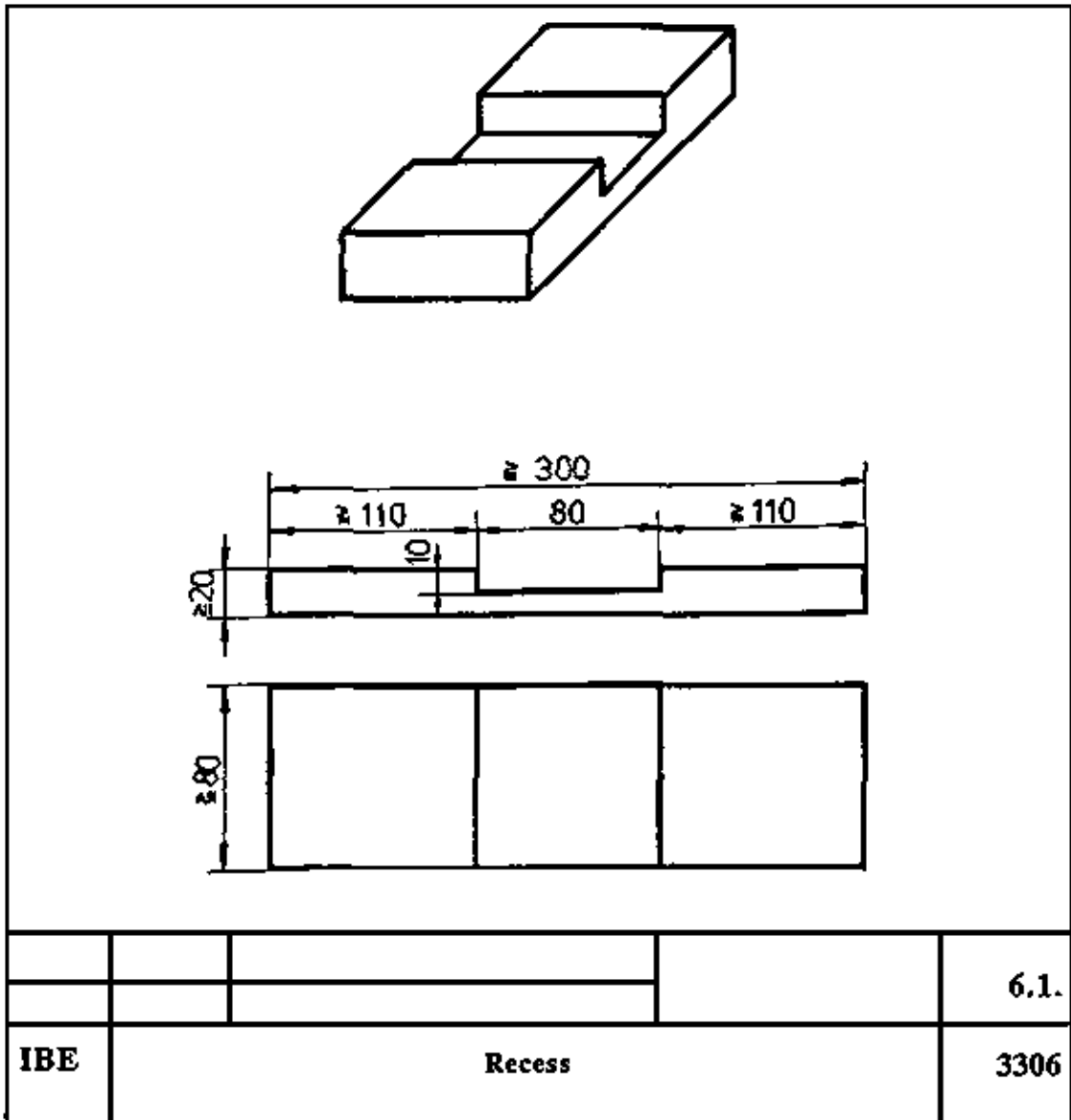

### Instruction Example 6.2.: Slot Hole and Dovetail Hole

Mortising of through recesses at the edge of a workpiece to be practised on planed boards or strips.

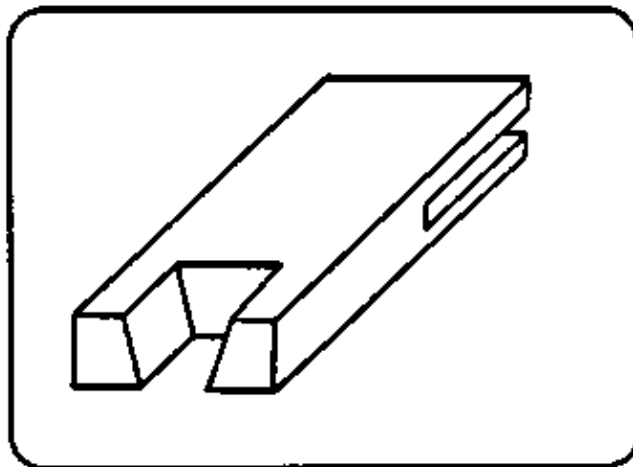

Material

Planed boards or strips, end-grained narrow faces worked rectangularly

Width: not less than 60 mm

Length: not less than 250 mm

Thickness: not less than 20 mm

### Tools

Frame saw, ripping chisels of different width, hard wood or hard rubber mallet, marking gauge

### Measuring and testing means

Folding rule or measuring tape, protractor, sliding square (bevel)

### Auxiliary

Carpenter's bench, screw clamp, packing wood, tool grinder, whetstone, stoning fluid, pencil

### Necessary previous knowledge

Reading of drawings, measuring, scribing, sawing, testing, sharpening of tools

### Explanations to the working drawing

? – equal to or greater than

#### Sequence of operations – slot

#### Comments

- |    |  |  |
|----|--|--|
| 1. | Check and prepare the tools.   |  |
| 2. | Scribe the length and thickness of the slot on the workpiece according to the given dimensions.            | Use a rule and a marking gauge.  |
| 3. | Clamp the workpiece in the carpenter's bench.  | The scribed end-grained narrow face is on top  |
| 4. | Give a cut with the saw close to the scribed lines parallel the grain up to the transverse limiting lines. | Guide the saw along the halves of the scribed lines towards the face to be chiselled out.                                  |
| 5. | Clamp the workpiece – with the longitudinal narrow face on top – on the plate of the carpenter's bench.    | The screw clamp should fasten the packing wood, the workpiece and the plate of the carpenter's bench as a whole.           |
| 6. | Precut the transverse limiting line with the ripping chisel between the edges cut by saw.                  | One hand takes the ripping chisel blade; do not guide the ripping chisel at its full width, lilt it slightly when pulling. |
| 7. | Recess the slot hole by  |  |

The cutting edge of the ripping chisel blade should be pointed at the transverse limiting line.

- driving in the ripping chisel
  - at the precut transverse limiting line, vertically, across the grain,
  - at a small distance from it and diagonally to the grain.

First cut off thin chips only.

– enlarging the funnel-shaped recess up to half the width of the workpiece and up to about 2/3 of the slot length.

8. Reclamp the workpiece with the longitudinal narrow face on top.
9. Cut through the slot hole – according to the operations Nos. 6 and 7 and by driving in the ripping chisel into the end-grained narrow face with the grain.
 

First chisel out the funnel-shaped recess, then cut off the wood fibres across the grain and finally split them off in longitudinal direction. Caution when mortising the last central wood layers in order not to damage the opposite slot edges!
10. Check the mortised slot edges for straightness and flatness.
 

Hold a thin straight strip fitting the slot hole (use a side of the try square) against the surface and compare; slot edges and test surface must be snugly fitting on each side.

### Sequence of operations – dovetail hole

### Comments

1. Scribe the length of the dovetail hole on the opposite wide faces of the workpiece according to the given dimensions.
 

Use a marking gauge and place it on the narrow face of the cross-grained wood.
2. Clamp the workpiece in the carpenter's bench with the narrow face of the cross-grained wood on top.
3. Scribe the width and the bevel of the hole both on the narrow and wide end-grained faces.
 

For scribing the bevels use a sliding square (bevel).
4. Give a cut with the saw at the marked lines up to the limiting transverse lines.
 

Guide the saw acc. to operation No. 4 (making slots)!
5. Fasten the workpiece with a screw clamp on the plate of the carpenter's bench with the wide face on top.

6. Precut the limiting transverse line acc. to operation No. 6 (making a slot hole).
7. Recess the dovetail hole by
- driving in the ripping chisel at
    - the precut transverse limiting line, vertically, across the grain;
    - at a small distance from it and diagonally to the grain.
  - Reclamp the workpiece, with the opposite longitudinal narrow face being on top.
  - Cut through the dovetail hole (acc. to the operations Nos. 6 and 7 – making slots).
8. Check the quality of the mortised dovetail edges (according to the sequence of operations) for flatness.
9. Sharpen the ripping and mortising tools, if necessary.
- Use a ripping chisel of medium or greater width;
- when driving in the ripping chisel across the grain, hold its blade in parallel to the edges cut by saw.
- First cut off thin chips only.

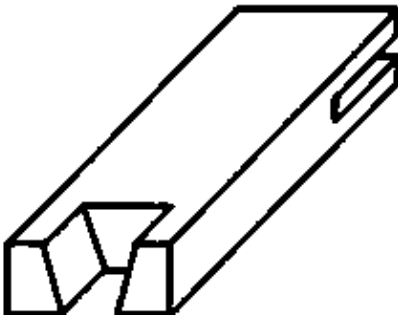
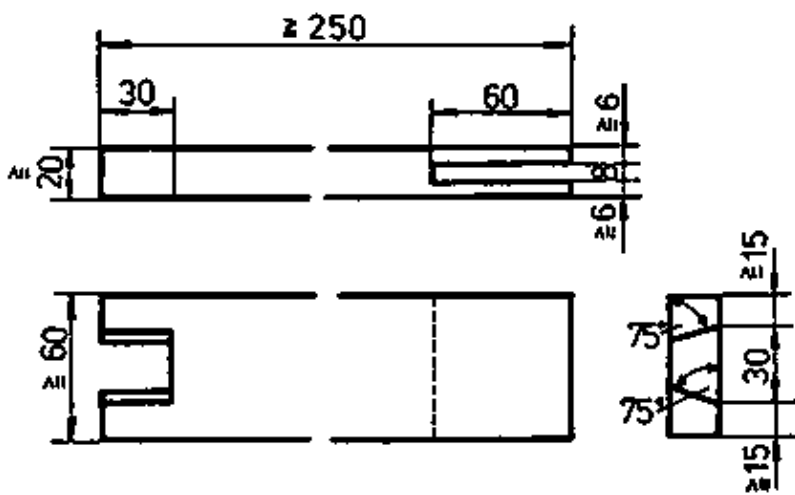

			
			
			6.2.
<b>IBE</b>	<b>Slot Hole and Dovetail Hole</b>		<b>3306</b>

### Instruction Example 6.3.: Mortise

Making continuous conical mortises to be practised on planed boards.

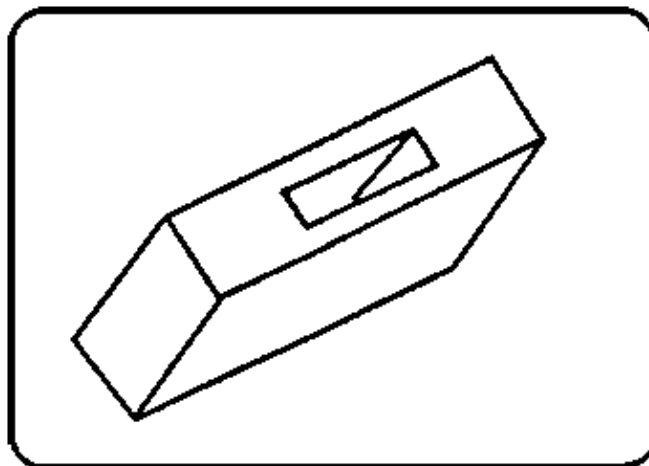

## Material

Planed boards

Width:	80	mm
Length:	not less than	250 mm
Thickness:	not less than	35 mm

## Tools

Ripping chisel of larger width, cross-cut or firmer chisel (10 mm to 12 mm wide), hard wood or hard rubber mallet, marking gauge, scribe

## Measuring and testing means

Folding rule or measuring tape, try square 90°

## Auxiliary accessories

Carpenter's bench, tool grinder, whetstone and stoning fluids, pencil

## Necessary previous

Reading of drawings, measuring, scribing, checking, sharpening tools

## Explanations to the working drawing

? – equal to or greater than

Sequence of operations	Comments
1. Check and prepare the tools.	For proper guidance of the chisel during mortising mark out the length and the bevel of the mortise with pencil strokes on one wide face.
2. Scribe the length, thickness and bevels of the mortise on the workpiece acc. to the given dimensions.	
3. Clamp the workpiece in the carpenter's bench.	The longitudinal narrow face with shorter mortise edges (to be chiselled rectangularly) is on top.
4. Chisel a notch in the centre of the mortise diagonally to the wood grain and enlarge it up to some millimeters close by the limiting transverse lines.	Use a firmer or ripping chisel the width of which is approx. 2 mm less than thickness of the mortise; the cutting edge of the blade of the firmer (ripping) chisel should be alternately tilted upwards and pointed at the mortise centre; guide the chisel in parallel to the wide face of the workpiece!
5. Drive in the firmer chisel (cross-cut chisel) at the opposite limiting lines, vertically, across the grain.	The cutting edge of the chisel blade must be pointed at the transverse scribed line; drive in the chisel blade true to the scribed line and at an angle of 90° to the narrow face of the workpiece as well as in parallel to the wide faces.

- |     |  |   |
|-----|--|---|
| 6.  | Split off the wood chips by driving in the firmer chisel   | Guide the channel of the chisel in parallel to the grain.   |
| 7.  | Deepen the mortise approx. up to half the width of the workpiece acc. to the operations Nos. 5 and 6.  |   |
| 8.  | Finish up the opposite wide faces of the mortise by accurately guiding the ripping chisel along the scribed lines, in parallel to the workpiece wide faces, up to the pre-chiselled depth. | Use a wide chisel; the cutting edge of the chisel blade is pointed at the wide face of the mortise to be produced.  |
| 9.  | Reclamp the workpiece with the opposite narrow face on top.  |   |
| 10. | Prechisel the mortise acc. to operation No. 4.   |   |
| 11. | Drive in the firmer chisel (mortise chisel) at the opposite limiting lines, diagonally to the grain, acc. to the diagonal scribed lines on the wide face of the workpiece.                 | Guide the chisel acc. to operation No. 5 (with the exception of the angular guidance of the blade).   |
| 12. | Cut through the mortise acc. to the operations Nos. 6 to 8.  |   |
| 13. | Check the inner surfaces of the mortise for dimensional accuracy and flatness.   | Use a straight strip fitting into the mortise (use a side of the try square, if available), place it on the faces and compare; the faces of the mortise and those of the testing device must be snugly fitting on each other. |
| 14. | Sharpen the ripping and mortising tools, if necessary.   |   |

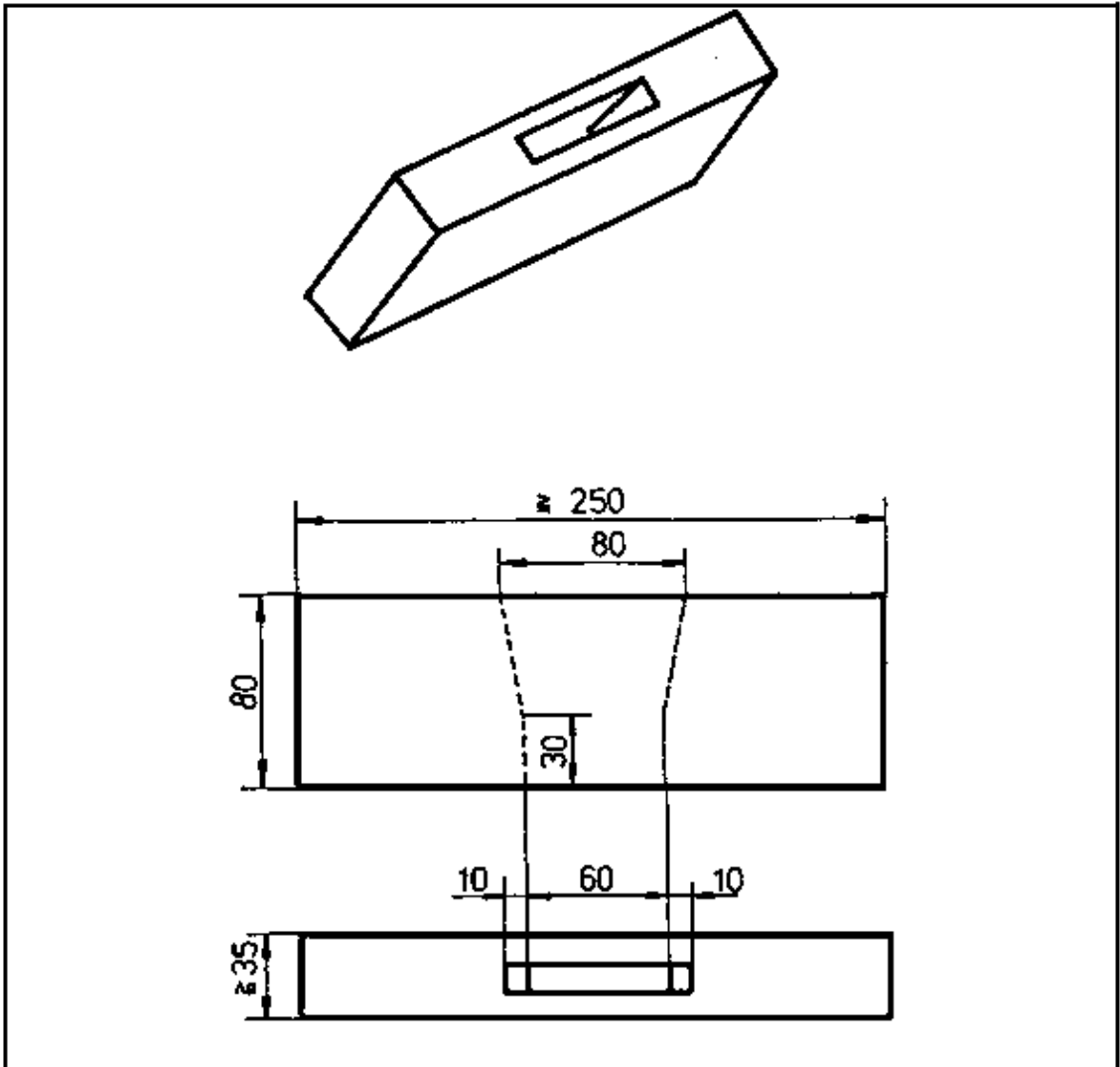

				6.3.
<b>IBE</b>	<b>Mortise</b>			<b>3306</b>

**Ripping and Mortising – Course: Manual woodworking techniques.  
Trainees' handbook of lessons**



## Table of Contents

<b><u>Ripping and Mortising – Course: Manual woodworking techniques. Trainees' handbook of lessons</u></b> .....	<b>1</b>
<u>1. Purpose and Application of Mortising and Ripping</u> .....	1
<u>2. Types, Construction and Mode of Action of Mortising and Ripping Tools</u> .....	1
<u>3. Preparation for Mortising and Ripping</u> .....	5
<u>4. Precutting of Recess Edges by Means of Ripping Tools</u> .....	6
<u>5. Chiselling out Recesses</u> .....	8
<u>6. Ripping of Faces, Edges and Corners</u> .....	15





# Ripping and Mortising – Course: Manual woodworking techniques. Trainees' handbook of lessons

Institut für berufliche Entwicklung e.V.  
Berlin

Original title:  
Arbeitsmaterial für den Lernenden  
“Stemmen und Stechen”

Author: Rolf Jakoby

First edition © IBE

Institut für berufliche Entwicklung e.V.  
Parkstraße 23  
13187 Berlin

Order No.: 93–35–3306/2

## 1. Purpose and Application of Mortising and Ripping

Mortising and ripping are methods of the manual chip-forming woodworking technique. They serve to

- make recesses in the wood,
- prepare surfaces for joining,
- remove adherent material and glue residues.

The purpose of mortising and ripping is

- to manufacture snugly fitting wood joints by shaping the mating surfaces true to dimensions,
- to make recesses for the setting of fittings,
- to shape rough and fine wood surfaces,
- to secure a high surface quality of wood surfaces.

When mortising the tools are driven into the wood by means of a striking tool. Ripping is the finishing of the wood by guiding and pushing the tool with both hands.

## 2. Types, Construction and Mode of Action of Mortising and Ripping Tools

For different tasks various mortising and ripping tools are applied. Main parts of these tools are:

- the steel blade and
- the haft fixed to it.

The single types mainly differ in the form and the sizes of the steel blade (see Fig. 1).

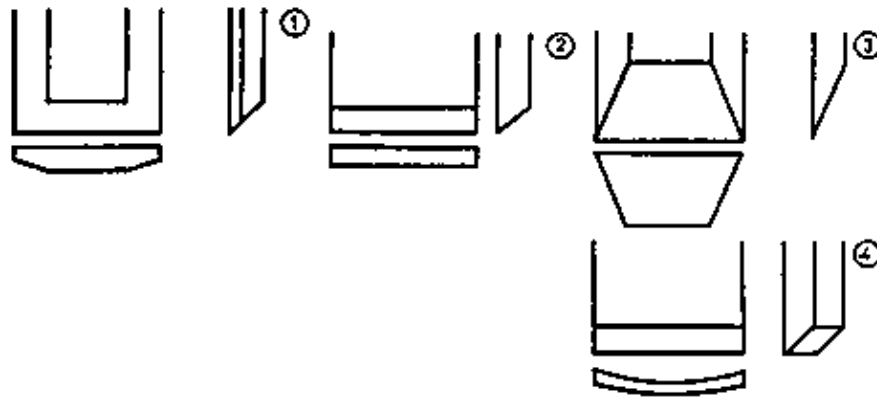

Figure 1 Shapes of steel blades for mortising and ripping tools

1 ripping chisel, 2 firmer chisel, 3 cross-cut chisel, 4 firmer gouge

Tabl. No. 1 represents the features and usability of mortising and ripping tools as shown in Fig. 1.

**Table 1: Types of Mortising and Ripping Tools**

Name, sizes of the blade	Features	Application
ripping chisel – width 4 mm to 50 mm	the blade is wider than thick, with side chamfer	– for precutting and chiseling out rectangular and acute-angled recesses for wood joints
– thickness 2.5 to 5 mm		– for recessing fittings – for making recesses in surfaces – for removing adherent material and glue residues
firmer chisel width 16 mm to 50 mm	the blade is wider than thick, without side chamfer	– for precutting and chiseling out right-angled recesses – for recessing fittings – for making recesses in surfaces
cross-cut chisel – width 2 mm to 26 mm – thickness 12 mm to 15 mm	the blade is mostly thicker than wide, with or without side chamfer	– for chiseling out mortises
firmer gouge – width 6 mm to 50 mm	the blade is hollow	– for making round recesses

The parts of the mortising and ripping tools are:

- the blade
- the handle (haft)
- the shoulder (collar)
- the clamp (metal rings)
- the tang
- the button for beating
- the cutting edge

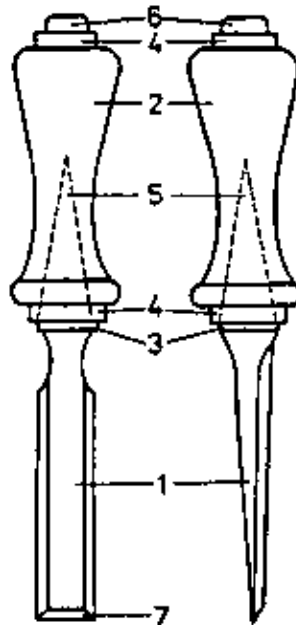

Figure 2 Parts of the mortising and ripping tools

*1 blade, 2 haft, 3 shoulder (collar), 4 clamp (metal rings), 5 tang, 6 button for beating, 7 cutting edge*

Being deeply inserted into the haft (above the shoulder) the tang ensures a firm connection between the blade and the grip. Blade and haft must form **one** common straight line (align). With not aligning tools you cannot hold the exact mortise direction.

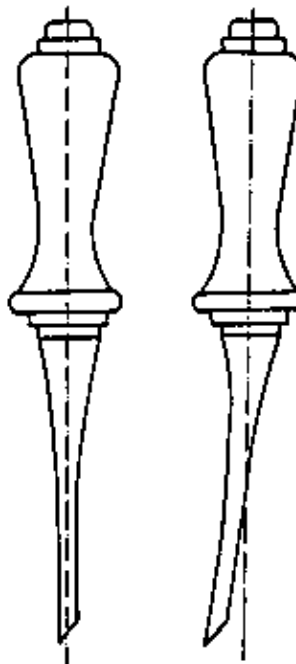

Figure 3 Requirements on mortising tools

*1 tool in working order, 2 tool out of order*

The haft is made of hard wood. The metal rings on both ends of the haft secure the wood against splitting up.

The cutting edge of the steel blade has the basic form of a one-sided wedge. The best wedge angle is between  $25^\circ$  and  $30^\circ$ . With too obtuse-angled wedges the wedge **resistance** is too high, with too acute-angled wedges that of the body being worked is too high.

The wedge angle forming surfaces of the cutting edge are called:

- face
- flank

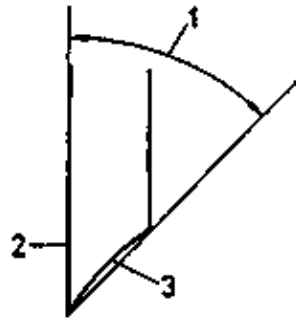

Figure 4 Cutting edge of the steel blade

*1 wedge angle, 2 face, 3 flank*

Because of the one-sided bevelled cutting edge the mortising tools can cut the wood with different effort in all directions. The blades of appropriate firmer chisels and mortise chisels are 4 mm to 50 mm wide. In order to prevent the blade from getting jammed the blade's width must always be smaller than that of the aperture in the wood. Appropriate striking tools for mortising are:

- the round mallet
- the edged mallet
- the round hard rubber mallet

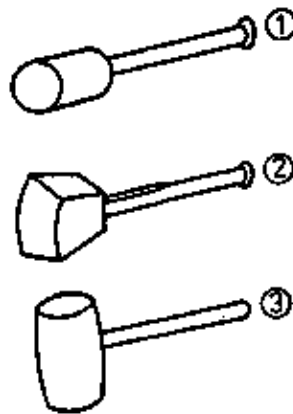

Figure 5 Striking tools

*1 round mallet, 2 square hard wood hammer, 3 round hard rubber mallet*

Inappropriate striking tools are:

- axes and hatchets
- metal hammers of all types.

Within a short time they will destroy the knob for beating the grip and thus increase the danger of accidents during work.

Select appropriate mortising tools for the following tasks:

a) Making recesses with an acute angle

---



---

b) Making mortises

---



---

Why is an axe or a metal hammer unsuitable as a striking tool for mortising?

---

---

---

### 3. Preparation for Mortising and Ripping

#### 3.1. Preparation of the Tools

Mortising and ripping tools in bad condition and with a dull cutting edge cause imperfect quality of the products. Moreover, they require a higher effort. That is why only tools should be applied which are in a proper condition. It is important that haft and blade are firmly connected with each other. In case of loose blades

- exact working is not possible,
- there is the danger of being hurt.

Loose blades will snugly fit again by sticking wooden or textile addings in the haft.

Dull tools must be sharpened.

The sharpening of tools (as done with plane irons) is carried out in two steps:

- grinding the blade by means of a grinding wheel
- honing on a whetstone

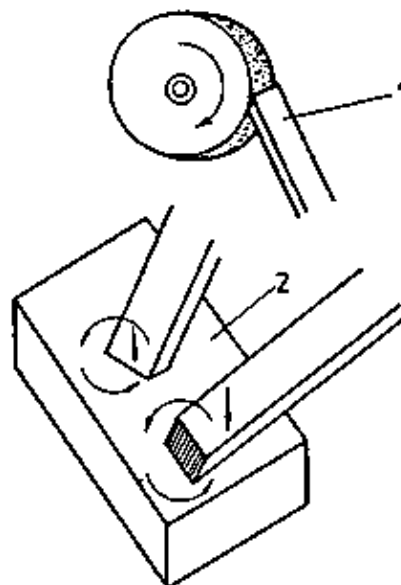

Figure 6 Sharpening of the tools

*1 grinding the steel blade by means of a grinding wheel, 2 honing on a whetstone*

The face of a firmer gouge with hollow blade is honed with a rounded whetstone.

For transport the cutting edges of the tools are to be secured against damage!

Striking tools should be checked for tightly fitting handles.

Loose handles must be wedged firmly and reliably!

#### 3.2. Preparation of the Workpieces

Timbers the working surfaces of which feature growth defects, such as

- larger knots,
- cracks,
- non-uniform grain direction, are unsuitable for mortising and ripping.

In order to ensure a high-quality work the workpieces should be scribed true to size. Before working them, mark out the respective areas of the workpiece.

### 3.3. Preparation of the Workplace

A carpenter's bench or work bench with clamping devices can be used for ripping and mortising smaller workpieces. For making recesses (holes) the workpiece can be clamped in accordance with the position of the respective area to be worked:

- between the bench clamps or
- with screw clamps on the bench plate.

Figure 7 Clamping the workpiece on a carpenter's bench

*1 between bench clamps, 2 with a screw clamp*

In case of ripping the workpiece must be fixed rigidly.

For working larger workpieces horses are suitable where the workpiece is placed on or clamped on with screw clamps. When mortising the trainee can also sit sideways on the workpiece and weigh it with his body weight.

When mortising thinner, i.e. springy wooden workpieces place them on non-springy supports!

When cutting through workpieces be sure not to penetrate the support!

The mortising and ripping tools as well as the striking tools should be placed so to be at hand. Make sure that the hafts of the tools lie always in the direction of the trainee.

Why should the mortising and ripping tools be put away with the hafts facing the trainee?

---



---



---

### 4. Precutting of Recess Edges by Means of Ripping Tools

Precutting along the scribed lines for the recesses to be mortised in the wood ensures dimensional accuracy and straightness of recess edges

- which cannot be mortised accurately to dimension,
- which cannot be cut in by means of sawing tools.

Precutting is mainly done in case of recess edges across the grain. In doing so the wood fibres are cut on the surface by means of the ripping chisel.

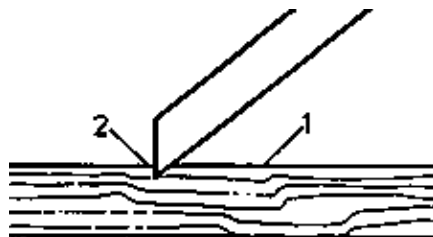

Figure 8 Precutting of wood fibres along the edges of the recesses

*1 wood fibres, 2 cutting edge of the ripping chisel*

For precutting and the subsequent mortising of recesses

- smaller workpieces are clamped on a carpenter's bench or on a bench plate.
- larger workpieces are fixed on horses or (not too high) supports.

Suitable cutting tools are firmer chisels and ripping chisels with steel blades of medium width and a wedge angle from 25° to 27°.

The cutting edge of the blade must be sharp in order to reliably cut the wood fibres. With a dull cutting edge no fine and straight cut can be achieved!

Precutting is carried out in the following steps:

- clamping the workpiece,
- checking the scribing: when scribing with a marking gauge pin or a scribe the wood fibres should be slightly cut in,
- selecting and checking the suitable cutting tool,
- cutting along the scribed line,
  - For this purpose the firmer chisel blade should be grasped by the hand.
  - The flank of the cutting edge is turned outwards.
  - The blade is slightly tilted sideways and back, so that the flank of the cutting edge is guided at a right angle and the cutting edge itself is guided at an acute angle to the surface of the workpiece.
  - During cutting the working direction is towards the trainee.

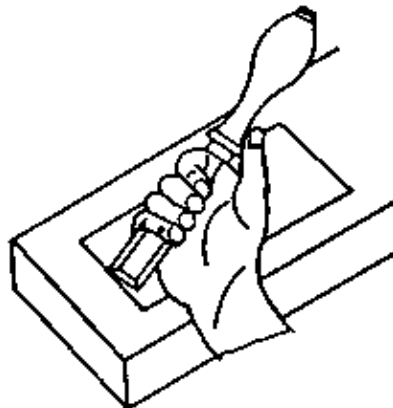

Figure 9 Precutting along the scribed line

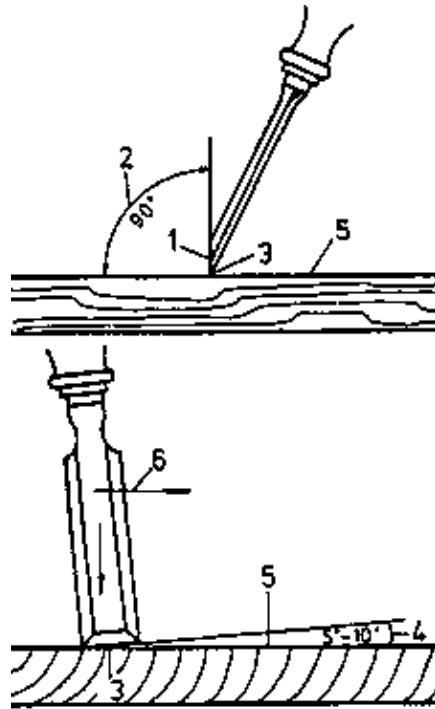

Figure 10 Precutting across the grain

1 flank of the cutting edge, 2 right angle, 3 cutting edge, 4 acute angle, 5 surface of the workpiece, 6 working direction

– notching along the scribed line diagonally to the grain and cutting off wood chips.

- Here the face of the tool's blade is turned outwards.
- The position and the cutting direction of the tool is the same as mentioned above.

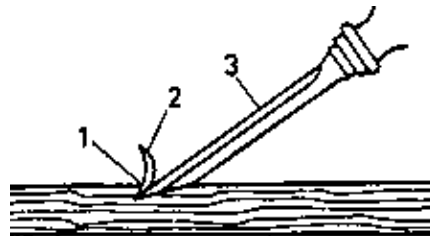

Figure 11 Notching along the scribed line

1 scribed line, 2 wood chips, 3 face of the blade

What are the features of sharp and dull cutting edges of mortising and ripping tools?

---



---



---

## 5. Chiselling out Recesses

The chiselling out of recesses (openings) for wood joints and for the mounting of fittings is carried out according to:

- the position of the workpiece area to be worked,
- length and width,
- depth and
- the shape of the recess.



## With recesses

– being manufactured on outer surfaces of the entire width or thickness of the workpiece (e.g. overlapping joints, dovetail joints, slots) two of the recess edges can be cut in by means of sawing tools. The third one is to be chiselled.

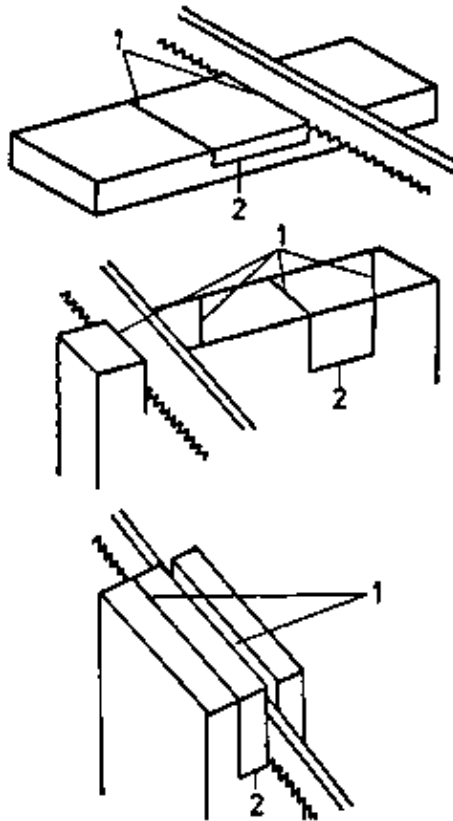

Figure 12 Cutting in two recess edges by means of sawing

*1 to be cut by sawing, 2 to be chiselled out*

– where all the five edges are inside the workpiece (e.g. covered mortises, fittings) all faces are to be chiselled out up to the working depth.

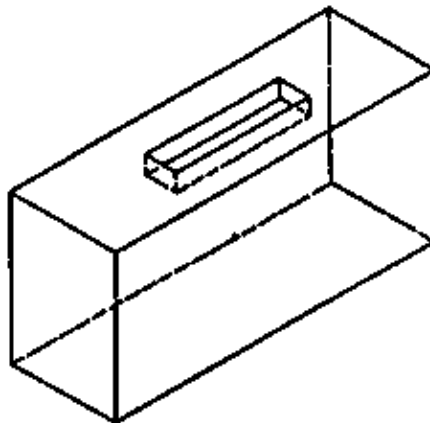

Figure 13 Depth limited recesses within the workpiece

– through the entire width or thickness of the workpiece (e.g. for through mortises) two recesses should be chiselled out (from the two opposite working faces, up to the half of the working depth each).

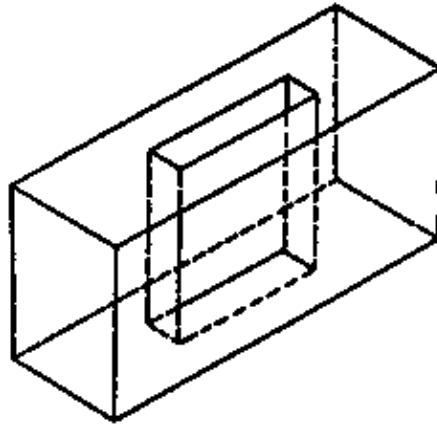

Figure 14 Recess chiselled through the workpiece (mortise)

The cutting through of holes from one face to the opposite face will result in size deviations and fraying of wood fibres at the edges!

When mortising

- the trainee encloses with one hand the haft of the mortising tool and guides it to the area to be worked,
- the other hand grasps the striking tool for beating the mortising tool.

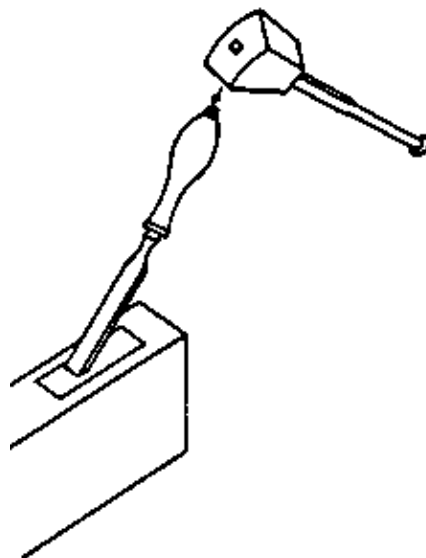

Figure 15 Handling of the mortising and ripping tools

### 5.1. Chiselling out Recesses (Overlap Joints)

The manufacturing of larger (longer) recesses comprises the following operations:

- clamp the workpiece,
- give a cut with the saw close to the limiting lines across the grain up to the marked working depth (cf. Fig. 12). In addition to it, cut in longer recesses sectionally,
- drive in the firmer chisel (from the centre of the recess, with the grain and in an acute angle to the working face.) Tilt the cutting edge of the blade slightly upwards!
- Split off the wood chips by bending the firmer chisel backwards and down,

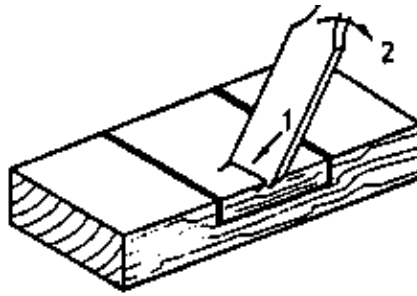

Figure 16 Driving in and bending the firmer chisel

*1 driving in with the grain, 2 bending backwards and downwards*

- work the recess in the opposite direction,
- repeat the alternate splitting off of the wood until the required recess depth is reached.

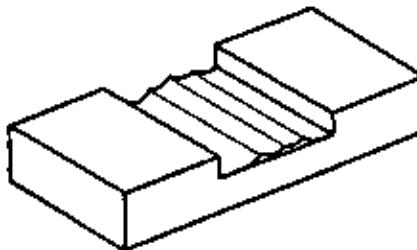

Figure 17 Chiselled recess

– flatten and smooth the prechiselled surface by reworking with the ripping chisel across and diagonally to the grain,

- the cutting edge of the ripping chisel blade is pointed at the working face,
- guide and push the ripping chisel with both hands.

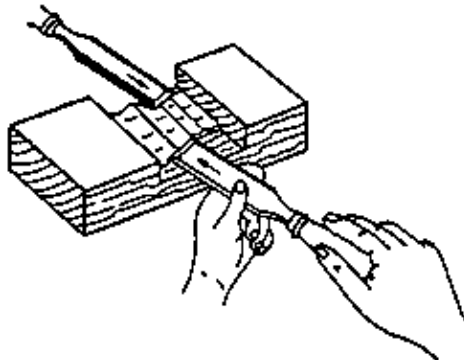

Figure 18 Reworking of the chiselled surface with the ripping chisel

Chiselling out and reworking of smaller (narrow) recesses can only be done with narrow firmer chisel blades across the grain. In doing so

- first cut off the thicker wood fibres,
- then (before reaching the envisaged working depth) cut off thinner chips from outside to inside.

Do not guide the cutting edge of the firmer chisel beyond the recess edge, in order to avoid fraying of wood fibres!

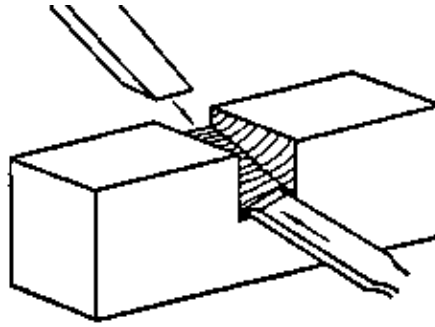

Figure 19 Chiselling of narrow recesses and reworking with the ripping chisel

## 5.2. Chiselling out Recesses (Openings) at the Edge of the Workpiece (e.g. Slots, Dovetail Holes)

The chiselling out of through holes and depth limited openings at the edge of the workpiece is divided into the following operations:

- give a cut with the saw close to the scribed lines in parallel to the grain, up to the transverse limiting lines (cf. Fig. 12),
- precut and notch at the limiting line across the grain (see Fig. 9 to Fig. 11),
- drive in the chisel at the precut scribed line and cut off the wood fibres. The cutting edge of the chisel blade
  - is pointed outwards at the scribed line,
  - is guided parallel to the face to be chiselled,

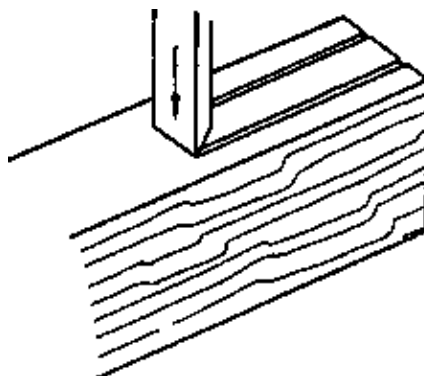

Figure 20 Driving in the firmer chisel at the scribed line and cutting off the wood fibres

- drive in the chisel close to the scribed line diagonally to the grain and split off the wood chips,

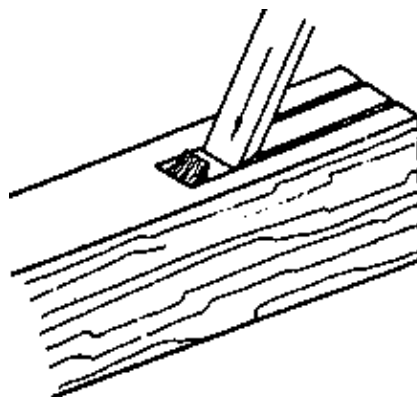

Figure 21 Splitting off the wood chips

- enlarge the funnel-shaped hollow by repeatedly cutting and splitting off wood fibres up to half the working depth (the centre of the workpiece).

In case of through holes: Stop chiselling out just before reaching the margin. Leave 1/3 of the remaining length as support for working from the opposite side!

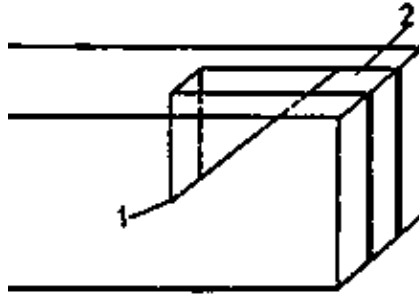

Figure 22 Recess chiselled from the first working surface of the workpiece

*1 half the working depth (centre of the workpiece), 2 supporting surface for working from the opposite side*

For through holes:

- reclamp the workpiece and chisel out its opening in the same way from the opposite side,
- drive in the chisel from the end-grained narrow face with the grain and split off wood layers,
- cut through the opening up to the centre of the workpiece and cut off the remaining wood chips.

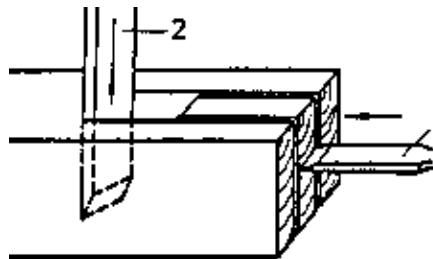

Figure 23 Chiselling of the recess from the second working surface

*1 cutting off the wood layers, 2 cutting through up to the centre of the workpiece*

On which side of the scribed line must you guide the saw blade, in order to manufacture the opening to be chiselled out true to size?

---

---

---

Why must through holes not be chiselled out from one side only?

---

---

---

### 5.3. Chiselling out Recesses in the Centre of the Workpiece, (e.g. Mortises, Holes for Fittings)

When chiselling out depth limited openings and through holes in the centre of the workpiece, perform the following operations:

- precut and notch at the limiting line across the grain (see Fig. 9 to Fig. 11),
- drive in the chisel along the limiting line with the grain. In doing so
  - the cutting edge of the chisel blade is pointed outwards,
  - the cutting edge of the blade is driven in at a distance of approx. 1 to 2 mm from the scribed line towards the opening's side,

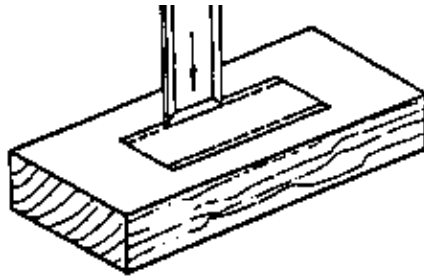

Figure 24 Cutting the wood fibres with the grain

– cut a notch in the centre of the opening by:

- alternately driving in the ripping chisel diagonally to the grain and
- splitting off wood chips,

– enlarge the funnel-shaped hole up to a distance of 3 to 5 mm from the precut transverse limiting line,

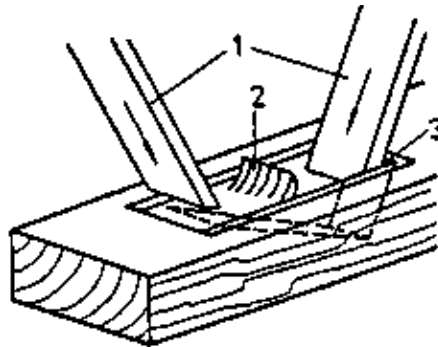

Figure 25 Caulking a notch in the centre of the opening

*1 diagonally to the grain, 2 splitting off the wood chips, 3 distance from the transverse limiting lines*

– drive in the chisel at the transverse limiting lines and cut off the wood fibres (see “Chiselling out Recesses at the Edge of the Workpiece”),

– cut and split off wood chips by:

- alternately driving in the chisel from the centre of the opening, with the grain and
- bending it backwards and downwards,

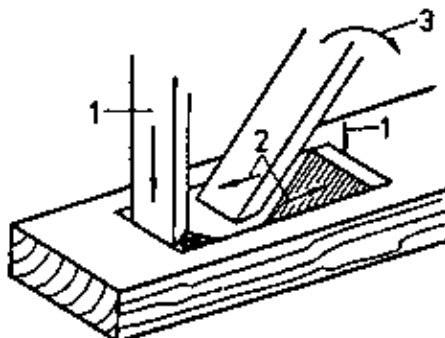

Figure 26 Alternately chiselling out the opening

*1 cutting the wood fibres, 2 cutting and splitting off the wood chips, 3 bending the firmer chisel backwards and downwards*

– the lateral cutting of the wood fibres at the 4 limiting lines and the subsequent splitting off of the wood chips is carried out

- with depth limited openings until the required depth is reached,
  - with through holes up to the centre of the workpiece,
- rework the chiselled faces up to the envisaged size of the hole by guiding the ripping chisel diagonally and across (in case of narrow holes) the grain,
- when chiselling out through holes
- reclamp the workpiece with the opposite side on top,
  - cut through the hole in the same way.

Before being chiselled out, depth limited and through holes may also be predrilled.  
When chiselling out predrilled holes

- first rework with the firmer chisel the surfaces at the 4 lateral limiting lines,
- then cut off the wood chips and
- finally rework the surfaces with the ripping chisel.

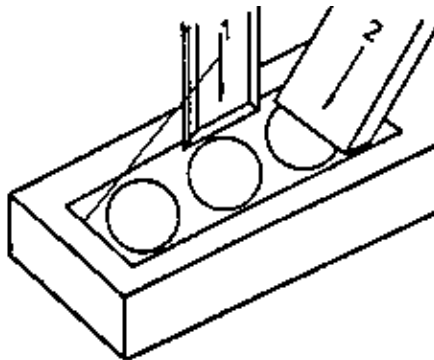

Figure 27 Chiselling out predrilled holes

*1 cutting the wood fibres with and across the grain, 2 splitting off the wood chips*

## 6. Ripping of Faces, Edges and Corners

### 6.1. Making Chamfers

If chamfers cannot be made by means of planing, ripping tools are applied to produce short narrow faces (chamfers) on the edges of wooden workpieces.

The method of chamfering is applied, e.g.,

- to avoid fraying of wood fibres at the bottom edges of the feet (legs) of tables, seating furniture, storage shelves and other products standing on the floor,
- to ensure a better insertion of the tenon into the mortise (in case of a hidden mortise and tenon joint).

Such chamfers are mainly made with a ripping chisel at the edges of end-grained faces.

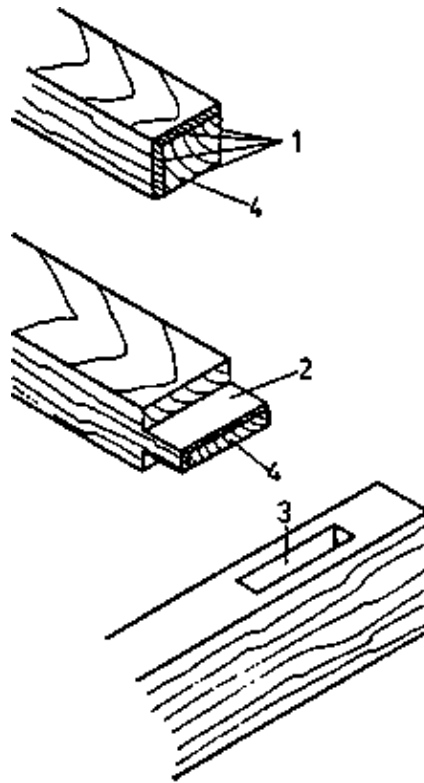

Figure 28 Making chamfers with ripping tools

*1 chamfers at the bottom edges of a foot (leg), 2 tenon, 3 mortise, 4 end-grained faces*

Chamfering with the ripping chisel involves the following sequence of operations:

- clamp the workpiece,
- cut off wood chips from the outside up to the centre of the edge. In doing so
  - the cutting edge of the ripping chisel blade is pointed at the workpiece,
  - the blade is guided at an angle of approx. 45° to the adjacent faces and with the grain,
- work the edge in the opposite direction up to the centre.

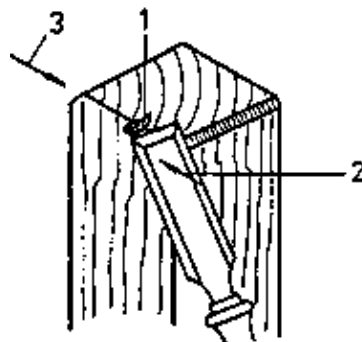

Figure 29 Chamfering with the ripping chisel, sequence of operations

*1 cutting off the wood chips, 2 working direction up to the middle of the edge*

In order to avoid fraying of wood fibres, do not guide the ripping chisel outwards beyond the middle of the edge!

## 6.2. Cutting off Projecting Material Residues

When cutting off adherent residues of material made of wood or plies, the appropriate working method depends on



- the type of the respective material,
- the grain (with materials made of wood).

When working thin wood materials (veneers)

- with the grain, the working direction corresponds always with the ascending wood fibres;
- across the grain, the workpiece must always be worked from outside towards the centre, in order to avoid fraying of wood fibres.

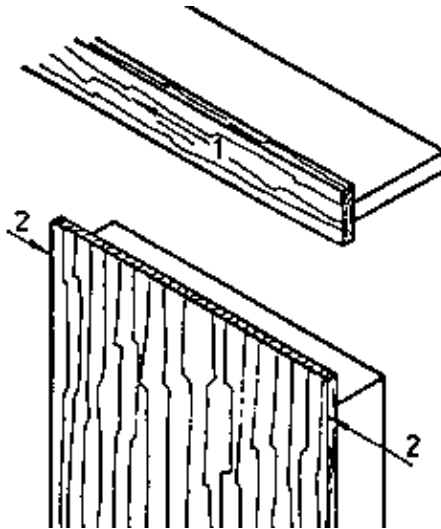

Figure 30 Cutting off thin wood-based materials (veneers)

*1 in the direction of the ascending wood fibres, 2 across the grain*

When working soft plastic materials the working direction is “from the outside to the centre of the workpiece”.

The cutting edge of the ripping chisel blade is pointed at the workpiece and is guided parallel to the working face. In doing so, pay attention that the surface of the workpiece is not damaged by the rip ping chisel blade.

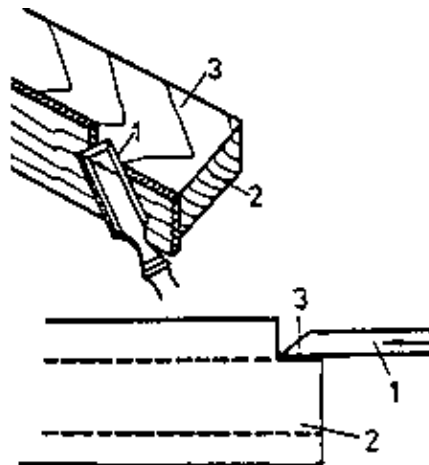

Figure 31 Guiding the ripping chisel blade in cutting off projecting material residues

*1 cutting edge of the blade, 2 workpiece, 3 surface of the workpiece*

### 6.3. Removing Adherent Glue Residues by Means of Ripping Tools

On completion of constructional gluing (i.e. making assembly groups and finished parts by sticking together wooden piece parts) glue residues – either still soft or hardened already – can be removed with the ripping chisel

- from the wide and narrow faces,
- from the corners.

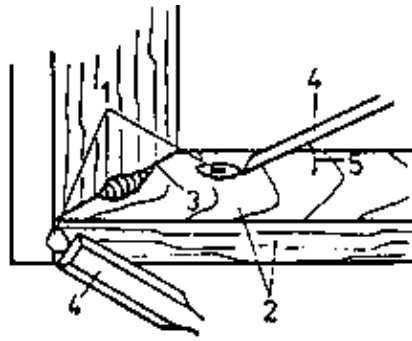

Figure 32 Removing adherent glue residues by means of ripping tools

*1 glue residues, 2 workpiece surfaces, 3 workpiece corners, 4 ripping chisel blade, 5 acute angle*

According to the different position of the glued joint and the possible working direction, the ripping chisel blade is brought up to the residual glue at an acute angle to the workpiece surface. In doing so, handle the tool with care, in order not to damage the workpiece surface.

**Operations with Routing Machines – Course: Mechanical woodworking techniques. Instruction examples for practical vocational training**



## Table of Contents

<b><u>Operations with Routing Machines – Course: Mechanical woodworking techniques. Instruction examples for practical vocational training</u></b> .....	<b>1</b>
<u>Preliminary Remarks</u> .....	1
<u>Instruction Example 05.1.: Bores</u> .....	1
<u>Instruction Example 05.2.: Quarter Chamfer</u> .....	4
<u>Instruction Example 05.3.: Quarter Chamfer and Half Chamfer</u> .....	7
<u>Instruction Example 05.4.: Slot</u> .....	10



# Operations with Routing Machines – Course: Mechanical woodworking techniques. Instruction examples for practical vocational training

Institut für berufliche Entwicklung e.V.  
Berlin

Original title:  
Lehrbeispiele für die berufspraktische Ausbildung  
“Arbeiten an Oberfräsmaschinen”

Author: Günter Hanisch

First edition © IBE

Institut für berufliche Entwicklung e.V.  
Parkstraße 23  
13187 Berlin

Order No.: 93–33–3405/2

## Preliminary Remarks

This material features four selected instruction examples for practising operations with routing machines. The trainees acquire skills in handling the machine, the machine tools and the necessary aids under varying operating conditions.

The necessary materials, machines and tools, measuring and testing means and auxiliary accessories have been cited to facilitate preparation and realization of exercises. Furthermore, required preliminary knowledge is given for preparing and undertaking the instruction examples. The exercises can be undertaken independently using workshop drawings and adopting the necessary work sequences. It is necessary to adhere to the sequence of instruction examples for these gradually become more complicated.

## Instruction Example 05.1.: Bores

The routing machine can undertake sound quality and accurate bores in wood. The borehole diameter can be steplessly aligned through the eccentric arrangement of the tool in the tool bearer. This instruction example concentrates on the setting up of the machine.

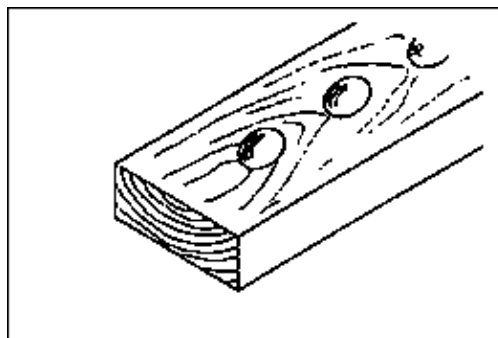

### Material

Soft wood, 25 mm thick, 130 mm wide, minimum length 420 mm, levelled and milled to thickness, narrow faces rectangularly planed

### Tools and chucking means

Cylindrical routing machine,  $d_1 = 16$  mm, eccentric chuck size 5, locking wrench for chuck screw and differential nut

### Measuring and testing means

Folding rule, vernier caliper, workpiece with tenons to check the bore (For example: Rod with clothing hangers from "Work with Wood Turning machines" Instruction Example 04.3.)

### Auxiliary accessories

Balancing roll, faceplate, screwdriver, stop strip 25 mm thick, screw clamps or screws for attaching the stop strip, try square and pencil

### Necessary preliminary knowledge

- assembly and function of a routing machine
- mode of operation of routing in conjunction with the chuck
- labour safety provisions for operating routing machines
- read drawings, marking, measuring and checking

Sequence of operations	Comments
1. Position work materials in readiness, check machine and tools for proper working condition	Check completeness of work materials, sharpness of tools and cleanliness of the machine
2. Position the tool in the chuck, turn the tool to the envisaged plan angle and tighten by means of adjusting screws	Determine the plan angle according to survey I in the work material "Using the shaping machine"
3. Balance the chuck by means of the balancing roll	Repeat until any unbalance has been eliminated
4. Position the chuck in the machine and tighten with differential nut	Before arrest the spindle with the retainer pin. After the differential nut has been chucked, release the arrest!
5. Set the machine rotational speed of $n = 12,000 \text{ min}^{-1}$	Remove the coverplate from the top part of the machine and insert the medium-sized V-belt pulley with V-belt, tension the V-belt again and seal the gear opening with the coverplate
6. Set the machine for bore operations – reset the circulatory lever – loosen the compensating mass	Turn out the hand wheel (on the right of the lower machines part) by left turning to the stop. After lowering the milling spindle must glide back independently to the initial position!
7. Set the bore depth Workpiece thickness = 35 mm – bore depth = 22 mm = distance of workpiece to table top surface 3 mm – fine setting with stop screw and spiral spacer	– turn the spiral spacer to medium pitch  – the tool must not be positioned on the machine table as the spindle is lowered!  – locator pin must not extend beyond the table surface!
8. Attach the stop strip to the machine table. Distance from middle locator pin to bearing surface = 65 mm	– position the strip laterally to the visual line  – mounting to the machine table can ensue either by means of machine screws and the tapped holes in the table surface or with two clamps
9. Pencil mark the stop strip	The borehole centre is pencil marked (locator pin middle) with the help of a try square
10. Swivel in the guard basket and tighten	The guard basket must not touch the positioned workpiece and must also enclose the tool in the upper



	spindle position
11. Check machine for proper operating condition	<ul style="list-style-type: none"> <li>– all removable machine parts and the stop must be securely chucked</li> <li>– check the unimpeded running of the spindle</li> <li>– do not leave any loose objects on the machine table</li> </ul>
12. Switch on the machine, first the main switch, then the machine switch	
13. Drill a hole in the test piece	<ul style="list-style-type: none"> <li>– position the workpiece according to pencil mark and hold firmly with both hands to the stop.</li> </ul> <p>Keep hands away from the bore area!</p> <ul style="list-style-type: none"> <li>– depress the foot lever slowly to the stop and return to rest position.</li> </ul>
14. Switch off the machine	– switch off the machine switch
15. Size and quality control. Given undersize, enlarge the plan angle of the workpiece in the chuck, given oversize, diminish the plan angle	<ul style="list-style-type: none"> <li>– check bore size with a vernier caliper or test tenon.</li> </ul> <p>Given size deviations turn off the main switch and alter the tool plan angle.</p> <ul style="list-style-type: none"> <li>– after correction to tool or step, repeat the working process from work sequence 10</li> </ul>
16. Once the size consistency of the test bores has been attained, the bores can be undertaken on the marked workpiece	
17. Switch off the machine, first machine switch then main switch	
18. Quality control	
<ul style="list-style-type: none"> <li>– cleanliness of the borehole top edge</li> <li>– top surface quality of the borehole wall</li> </ul>	

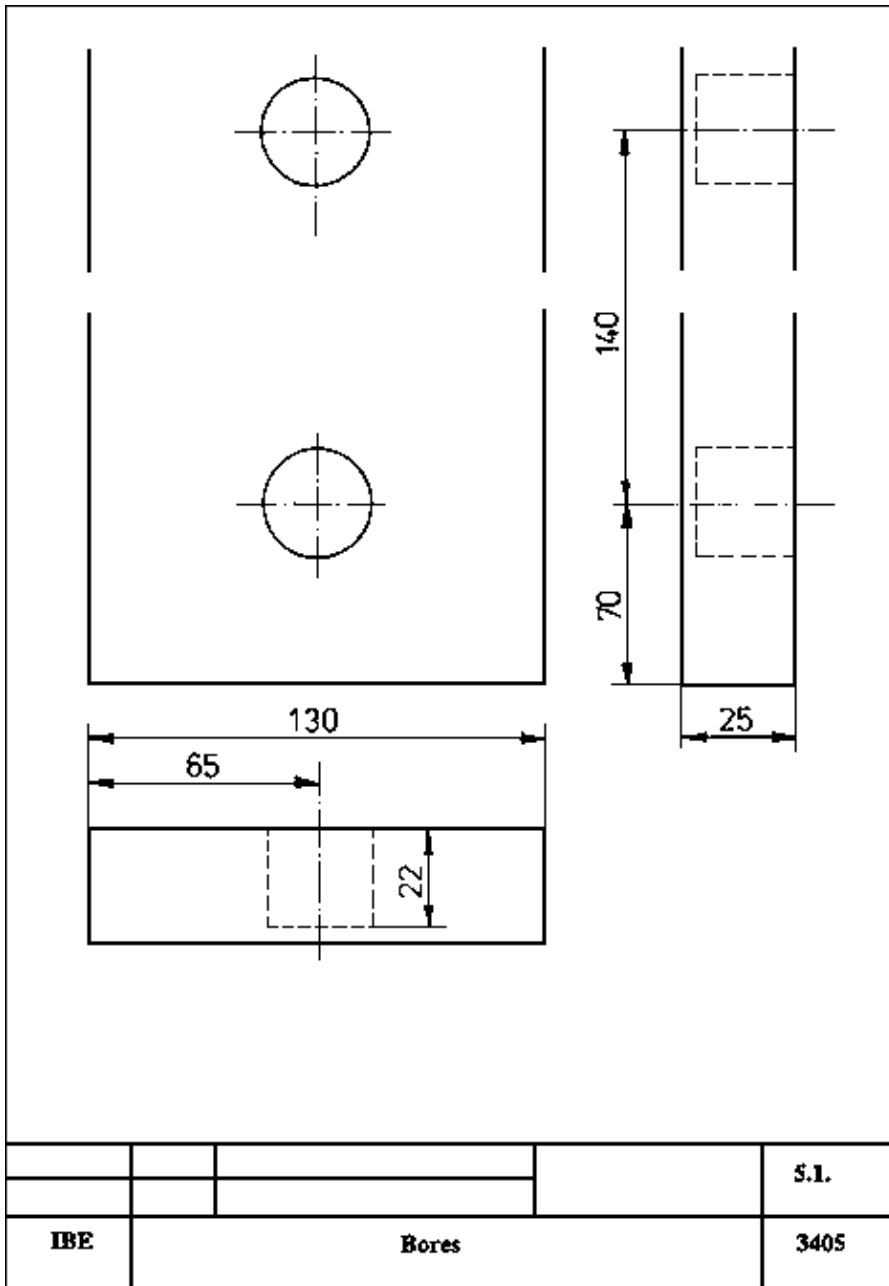

### Instruction Example 05.2.: Quarter Chamfer

Chamfers are milled as profiles on flat elements. The chamfer is mainly for the optical arrangement of furniture and narrow surfaces. In this instruction example the trainees practise such profiles using the routing machine.

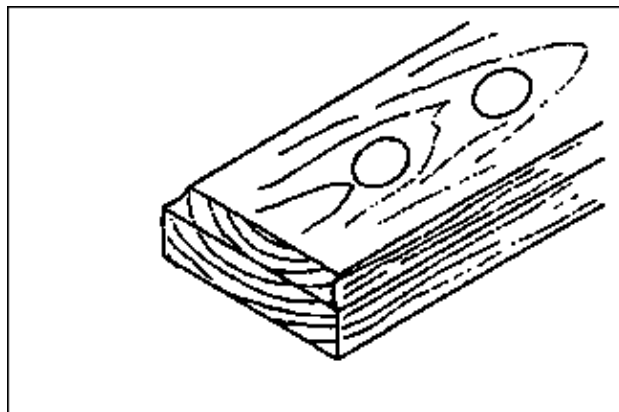

## Material

soft wood, 25 mm thick, 130 mm wide, minimum length 420 mm, planed and milled to thickness, narrow surfaces rectangularly levelled.

(The bored workpiece in the first instruction example can be used for further processing.)

## Tools and chucking means

16 mm chamfer routing machine, chuck for concentric tool chucking

## Measuring and testing means

Folding rule

## Auxiliary accessories

Stop strip, about 15 mm thick, approx. 750 mm long clamps or machine screws to fix the stop strip

## Necessary preliminary knowledge

- assembly and function of the routing machine
- mode of operation of milling tools
- knowledge and skills in chucking tools and setting up machines
- labour safety requirements for routing machine operations
- reading a drawing, measuring and checking

Sequence of operations	Comments
1. Position work materials in readiness, check machine and tools for proper working condition	Check completeness of work materials, sharpness of tools and cleanliness of machine
2. Set machine to routing operations – swivel the circulatory lever to the front hinged pins – firmly chuck the compensating mass	Tighten the hand wheel (right on the lower machine part) through right turn to the stop
3. Set the machine rotational speed of $n = 12,000 \text{ min}^{-1}$	If required, change the belt pulley set, ensure proper belt tension
4. Position the chuck in the machine spindle and tighten with the differential nut	Arrest the spindle beforehand. Release the arrest after differential nut has been firmly chucked
5. Chuck tool in the clamp	
6. Attach the stop strip to the machine table by means of machine screws or clamps	Arrange the stop strip laterally to the visual line. The support surface of the stop strip must be exactly above the axis of the locator pin. It should not extend beyond the table surface.
7. Set the milling depth – rough setting by height adjustment of the machine table  – fine setting by turning the spiral spacer and by setting the stop screw  – return spindle to rest position	Bring the spiral spacer to middle position.  Drop the spindle, the workpiece must not touch the stop strip  Position the workpiece onto the machine table and place one tool cutter to a workpiece edge. Set according to drawing dimensions  – all movable machine parts and the stop must be firmly chucked

	<ul style="list-style-type: none"> <li>– check the unimpeded running of the spindle</li> <li>– ensure that no loose objects are on the machine table</li> </ul>
8. Check machine for proper functioning and adherence to labour safety stipulations	
9. Position guard basket and chuck securely	In its highest workpiece position the guard basket must enclose the tool
10. Switch on the machine	<ul style="list-style-type: none"> <li>– switch on main switch</li> <li>– switch on machine switch</li> </ul>
11. Depress the foot lever carefully, loosen the holding pin and slowly depress the spindle by lifting the foot	
12. Mill a short chamfer on the test piece	
13. Switch off the machine	Spindle remains in depressed operating position
14. Size control	Given size deviation, a machine setting correction is undertaken
15. Switch on the machine and mill workpiece chamfers	<p>The first chamfer is milled at the grain end of the workpiece. Turn the workpiece 90° so that, during processing, the tool first of all engages the milled grain edge.</p> <p>Process the workpiece further in the work sequence</p>
16. Switch off the machine and return the spindle to rest position	
17. Quality control	Top surface quality in the chamfer and edges quality is corroborated

Possible additions:

- chamfer further workpieces
- the workpiece completed in this work instruction is processed further in the Instruction Example 05.3.

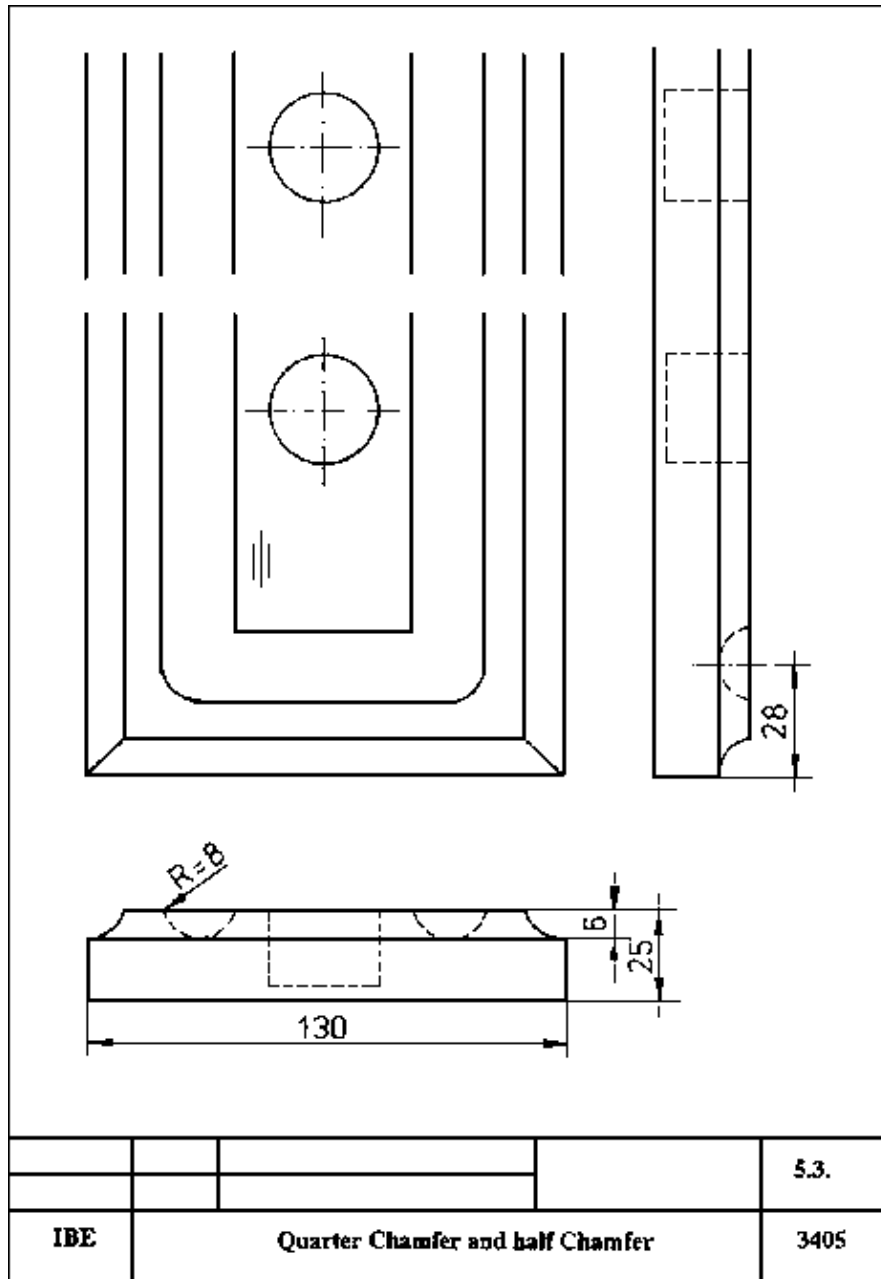

### Instruction Example 05.3.: Quarter Chamfer and Half Chamfer

A copying device on the routing machine is required for this exercise. This facility makes possible both a straight and curved processing of the workpieces.

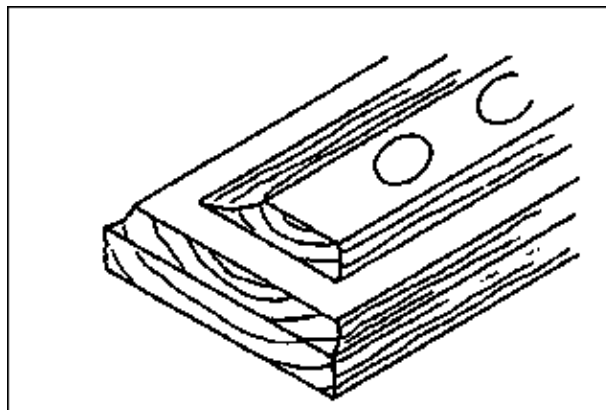

## Material

Workpiece from the Instructions Example 05.2.

## Tools and chucking means

16 mm chamfer routing machine (double-edged), chuck for concentric tool chucking

## Measuring and testing means

Folding rule

## Auxiliary accessories

Copying device

## Necessary preliminary knowledge

- assembly and function of the machine
- mode of operation of the milling tools
- knowledge and expertise in tool chucking, balance the chuck and set up the machine
- labour safety requirements for operating routing machines
- read a drawing, measuring and testing

## Necessary preliminary work

Prior to operations a copying device must be prepared as model facility for the workpiece. The copying device is described in the Trainees' Handbook of Lessons "Operations with routing machines". Prepare a test workpiece of commensurate dimensions for undertaking machine setting operations.

Sequence of operations	Comments
1. Position work materials in readiness and check machine for proper working condition	Check completeness of work materials, sharpness of tools and cleanliness of the machine
2. Set the machine to routing operations	
3. Set the machine rotational speed of $n = 12000 \text{ min}^{-1}$	
4. Position chuck in the machine and clamp	
5. Clamp tool in chuck	
6. Set the locator pin to first stage	
7. Place the copying device onto the machine table and attach the test piece of the device	Locator pin must engage the locator slot
8. Set milling depth – rough setting – fine setting	Lower the machine spindle and set the machine height so that the tool just touches the workpiece top surface  Lower the tool spindle by 6 mm by turning the spiral spacer or stop pin. Beforehand, remove workpiece from copying facility.
9. Attach guard basket	
10. Tighten the test piece in the device and check the proper functioning of the machine	Ensure, above all, the unimpeded passage of the locator pin in the locator slot of the copying facility!

11. Switch on the machine	As milling operations commence the locator pin should be in the top right-hand corner of the locator slot
12. Lower the spindle and mill the chamfer in the test piece. Return the spindle to rest position	
13. Switch off the machine Size and quality controls	If required correct the machine setting
14. Chuck the prepared workpiece and mill the rotating chamfer in the workpiece	Commence as for work sequence 11.
15. Return the spindle to rest position and switch off machine	Switch off the machine and main switches
16. Unchuck the workpiece, quality control	Slightly twisted grains at the chamfer edges are typical for this milling technology and do not denote inferior quality. The chamfers must be straight with no unevenness

Possible additions:

Further workpieces with the same dimensions can be processed.

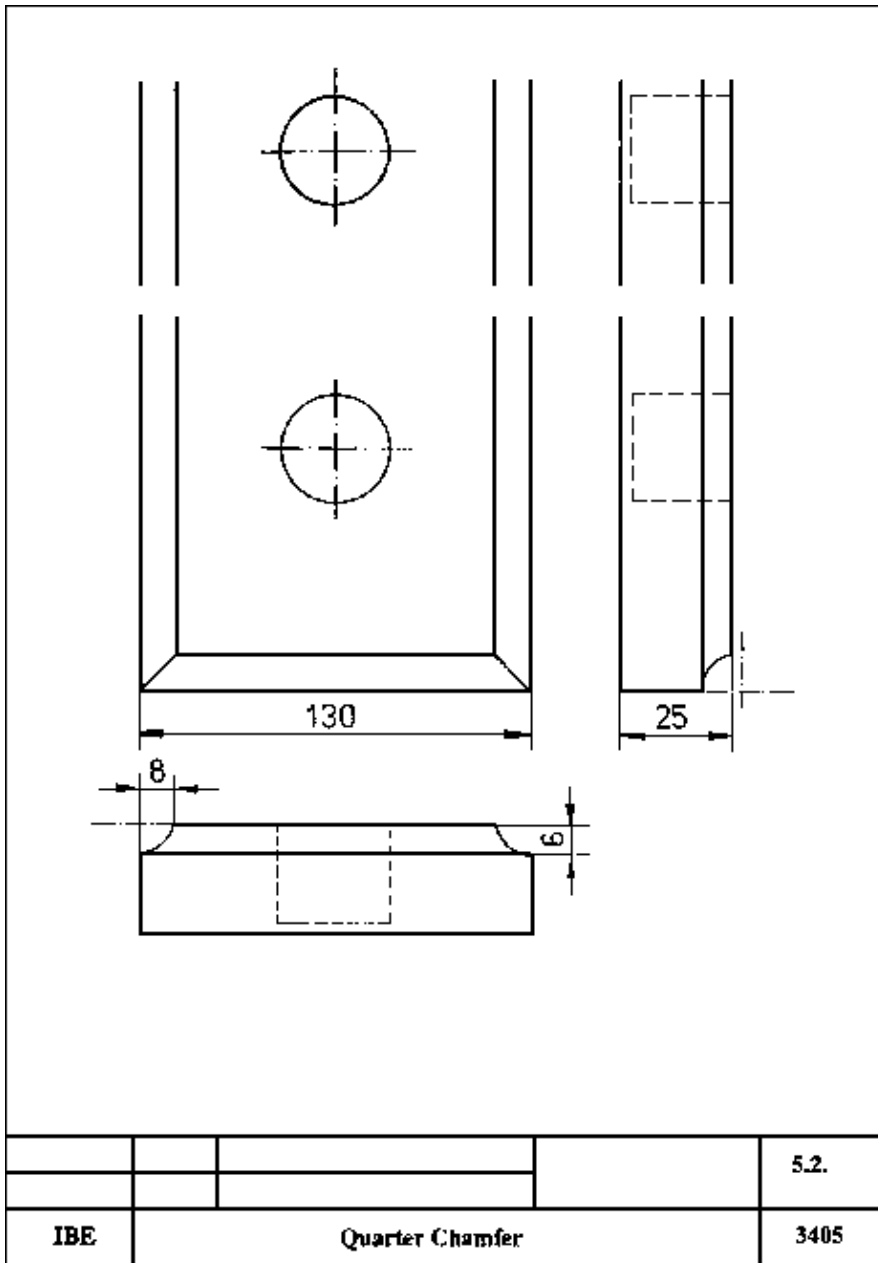

### Instruction Example 05.4.: Slot

Slots are frequently milled into the outer elements of furniture for insert shelves and partition walls. These slots are not generally throughgoing and their widths must be aligned exactly to the reference size of the element to be incorporated.

The present instruction example aims at consolidating and controlling the knowledge and skills acquired in previous instruction examples.



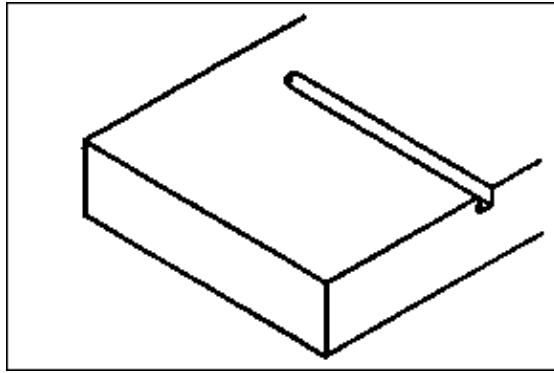

**Material**

Soft wood, 25 mm thick 130 mm wide, some 200 mm long, levelled and milled to thickness, narrow surfaces rectangularly levelled

**Tools and chucking means**

Cylindrical routing machine 4.5 mm or 5 mm in diameter, chuck for eccentric chucking, chuck size 1.5

**Measuring and testing means**

Folding rule

**Auxiliary accessories**

- a piece of playwood 6 mm thick as test piece for the fit
- stop strip of approx. 100 x 50 x 20 mm
- clamp

**Necessary preliminary knowledge**

All knowledge acquired in conjunction with operations for Instruction Examples 04.1. to 04.3.

Sequence of operations	Comments
1. Position work materials in readiness and check machine for proper working condition. Determine the workpiece reference faces	Check the completeness of work materials, tool sharpness and cleanliness of the machine
2. Set the machine to routing operations	
3. Set the machine rotational speed to $n = 18000 \text{ mm}^{-1}$	Change the belt pulley pair
4. Remove the chuck from the machine	
5. Chuck the tool into the chuck (chuck size 1.5)	Determine the plan angle according to survey I of the Trainees' Handbook. (The measure $d_2 = 6 \text{ mm}$ does not feature in the table. Heed the control questions in section 2.3.!)
6. Balance the chuck. Insert the chuck into the machine spindle and clamp tightly with the differential nut	Ensure cleanliness! After tight chucking, release the arrest!
7. Set the table height	
8. Set spindle stroke	
9. Fix the guide rule to the machine table	Arrange the guide rule in lateral position behind the locator pin

10. Set the guide rule to 47 mm from mid–locator pin to stop face	
11. Screw–clamp the stop strip to guide rule	Secure the stop at a distance of 109 mm from mid–locator pin to the left
12. Attach guard basket	
13. Check machine for functionality and labour safety parameters	
14. Position workpiece	Place workpiece to the left on the stop
15. Switch on the machine	
16. Press the workpiece to the stop and to the guide rule thereby lowering the spindle	
17. Milling a slot	Move the workpiece to the right on the guide rule
18. Raise the spindle	
19. Switch off the machine	
20. Control all size and correct plan angle in the event of size deviations	The slot width is checked with the 6 mm test piece. The test piece must slide easily into the groove
21. Quality control	Check the straightness of the slot and edge quality

Possible addition:

Further slots can be milled at the other workpiece end. Milling is also possible on the workpiece rear side. More slots can be milled together at desired distances. In that case the setting of the slip gauge between locator pin middle and stop face must be changed.

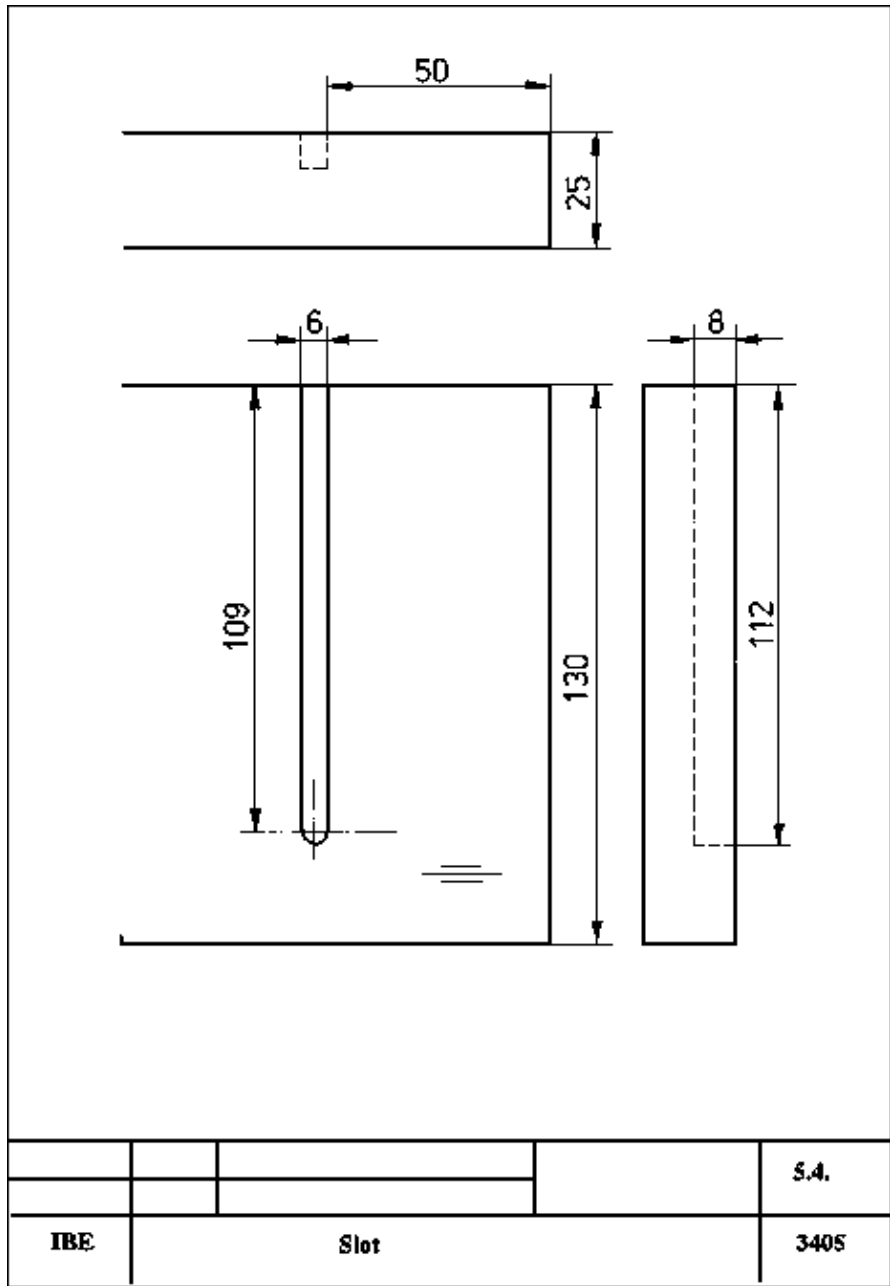



**Operations with Routing Machines – Course: Mechanical woodworking techniques. Trainees' handbook of lessons**



# Table of Contents

## **Operations with Routing Machines – Course: Mechanical woodworking techniques. Trainees' handbook of lessons**..... 1

1. The Purpose of Routing Machine Milling.....	1
2. Assembly of a Routing Machine.....	1
2.1. Operation Mechanism of the Machine.....	2
2.2. Drive.....	3
2.3. Chuck and Tool Mounting.....	4
3. Routing machine tools.....	7
4. Tool Guiding Possibilities.....	9
5. Basic Provisions of Labour Safety when Operating Routing Machines.....	10





# **Operations with Routing Machines – Course: Mechanical woodworking techniques. Trainees' handbook of lessons**

**Institut für berufliche Entwicklung e.V.  
Berlin**

Original title:  
Arbeitsmaterial für den Lernenden  
“Arbeiten an Oberfräsmaschinen”

Author: Günter Hanisch

First edition © IBE

Institut für berufliche Entwicklung e.V.  
Parkstraße 23  
13187 Berlin

Order No.: 93–35–3405/2

## **1. The Purpose of Routing Machine Milling**

The routing machine is a wood-working appliance. A great many processing operations are possible because of the special arrangement of the work spindle and the nature of the tools. The keynote fields of application are:

- profile milling and surface milling of workpiece narrow and wide faces,
- milling curved profiles and contours,
- copy milling operations
- producing ornaments and decorations.

## **2. Assembly of a Routing Machine**

The operations undertaken by the machine precondition the following main functions of a routing machine:

- stable workpiece support and all-round workpiece freedom of movement at table level,
- axial application and interruption of the milling tools,
- a high tool rotational speed,
- sound tool chucking facilities and quiet spindle running,
- simple and safe operations of machine elements, easily reached operating elements.

The heavy cast iron stand ensures a quiet and vibration-free running of the machine and the arrangement of the various elements enable application as:

- routing machine
- bore miller and
- shaping machine

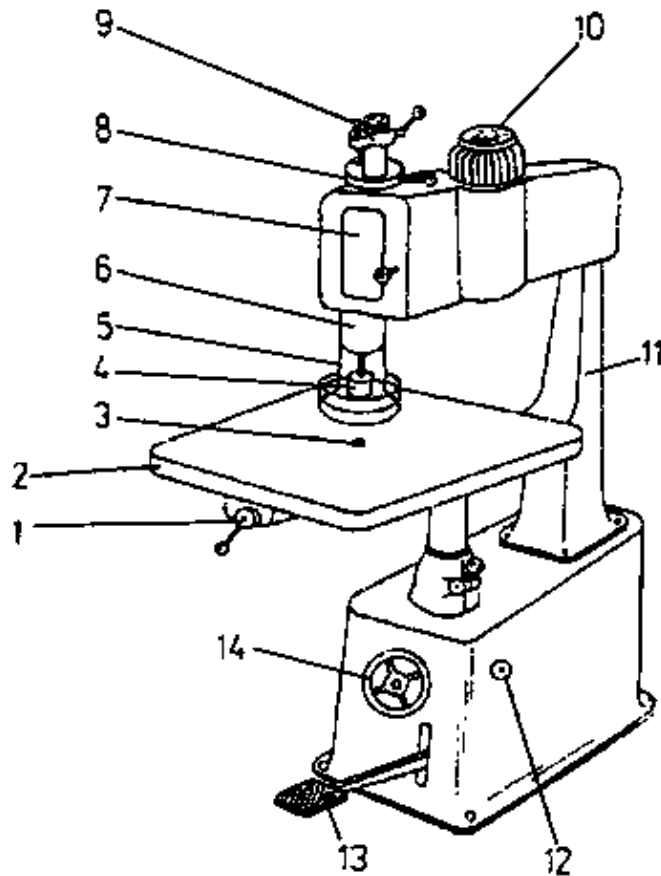

**Figure 1 – Routing machine**

*1 setting device for the locator pin, 2 machine table, 3 locator pin, 4 chuck, 5 guard basket, 6 milling support, 7 gear cover, 8 differential spacer, 9 compensating screw, 10 motor, 11 machine frame, 12 hand wheel to arrest the compensating mass, 13 foot level, 14 hand wheel for table adjustment*

## 2.1. Operation Mechanism of the Machine

In order to undertake surface milling, milling out and bores the spindle, in addition to the rotational movement, must also execute an axial feed movement.

Spindle lowering ensues by depressing the foot lever. The equalization mass compensates as counterweight for the weight of the milling support. Thereby the actuating forces are reduced. The spindle can be lowered for bore operations by depressing the foot lever or raised for routing operations, depending on the position of the reversing lever on the crank lever.

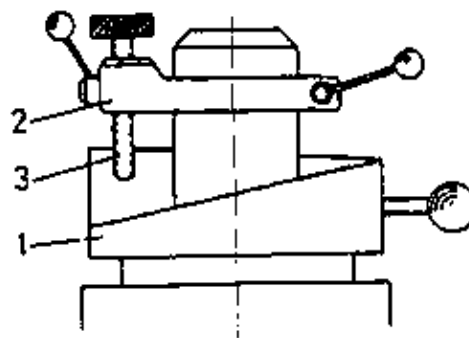

**Figure 2 – Spindle limitation**

*1 spiral spacer, 2 stop, 3 compensating screw*

The spindle stroke can be limited for setting the milling depth. The greatest possible spindle stroke is 100 mm. A stroke limitation of around 40 mm can be set by turning the spiral spacer. The stop can also be adjusted heightwise and, co-ordinated with the spiral space, make possible a height adjustment of between 0 and 100 mm. The stop screw makes possible fine setting. Instead of a spiral spacer other machine types feature a revolver head with a maximum of eight setting screws. Thereby it is possible to store a number of setting dimensions for later work assignments.

The machine table features a height adjustment facility. Setting ensues by turning the hand wheel. The shaft guide of the machine table can be arrested by means of a set-screw.

A locator pin has been positioned in a cavity beneath the spindle axis. The locator pin can be used for various tool diameters, that is to say it is interchangeable, for it features a height adjustment facility by means of which the pin can be raised in several stages over the table surface. The locator pin acts as stop for various locating facilities.

## 2.2. Drive

The routing machine is driven by an electric motor with a wattage of some 1.5 kW and a rotational speed of approx. 2850 min<sup>-1</sup>. The spindle rotational speed can be switched as desired by means of a flat belt gear or, using interchangeable belt pulley pairs, to 3000 min<sup>-1</sup>, 12000 min<sup>-1</sup> or 18000 min<sup>-1</sup>.

The lower spindle rotational speed is used for drilling simple bores into the borehole walls. It is desirable to use the medium rotational ranges when operating as shaping machine.

When undertaking routing operation with a small tool diameter, select the greatest rotational speed for attaining the necessary cutting speed.

Switching over to another rotational speed ensues by exchanging the one belt pulley pair for another set with a different speed ratio. The various belt pulleys are available as machine accessories.

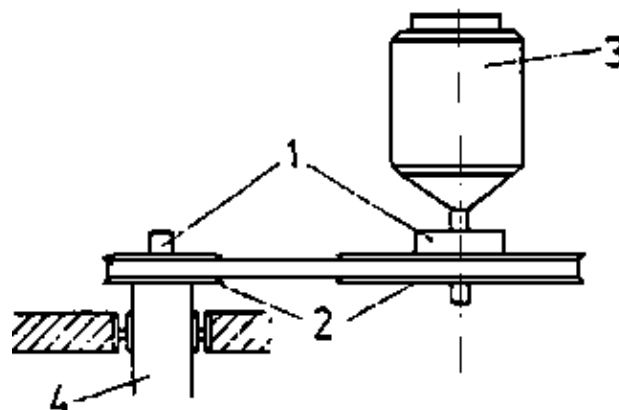

**Figure 3 – Machine drive**

*1 flat belt pulley pair, 2 V-belt pulley pair, 3 motor, 4 milling spindle*

Excessively high spindle rotational speeds exert a considerable strain on the spindle bearings. These elements must be properly maintained and tended to in line with the machine instruction manual provisions. All the movable parts of the machine must be kept thoroughly clean and greased regularly after a certain number of operating hours.

Depending on the hardness of the material, milling speeds of 20 ms<sup>-1</sup> to 80 ms<sup>-1</sup> are required. Cutting speeds of 1 ms<sup>-1</sup> to 15 ms<sup>-1</sup> are required for bores.

The cutting speed “v” in ms<sup>-1</sup> can be calculated from the formula  $v = d \cdot \pi \cdot n$

### Example:

Which cutting speed “v” applies when, given a spindle rotational speed of  $n = 12000 \text{ min}^{-1}$ , a tool measuring 20 mm in diameter (d) is to be used? ( $\pi = 3.14$ )

**Solution:**

$$v = \frac{0.020 \text{ m} \cdot 3.14 \cdot 12000}{1 \text{ min}}$$

$$v = \frac{0.020 \text{ m} \cdot 3.14 \cdot 12000}{60 \text{ s}}$$

$$v = \frac{12.56 \text{ m}}{2}$$

$$v = 12.56 \text{ ms}^{-1}$$

The cutting speed is  $12.56 \text{ ms}^{-1}$ .

The calculated cutting speed is still too low for routing operations. The determined cutting speed is, however, sufficient for boring and milling operations. As regards boring, the cutting speed is the top limit and the tool yields clean bore walls. The release of chips creates difficulties with deep boreholes. This rotational speed should therefore only be employed for bore operations of minimal bore depth.

**Exercise:**

Which maximum cutting speed results when using a 16 mm chamfer mill at a spindle rotational speed of  $12000 \text{ min}^{-1}$ ?

known:

unknown:

$$d = 16 \text{ mm} \quad v = d \cdot \pi \cdot n \quad v = ?$$

$$n = 12000 \text{ min}^{-1}$$

$$\pi = 3.14$$

### 2.3. Chuck and Tool Mounting

The utilization of single-cutter tools presupposes the eccentric chucking of the tools in the clamp. Consequently, a clearance angle is formed between tool surface and working face whereby lateral milling vis-à-vis the tool axis becomes possible. The eccentric tool clamping causes unbalance during rotation. This in turn, would lead to vibrations in the machine and subsequently, machine damage and serious accidents.

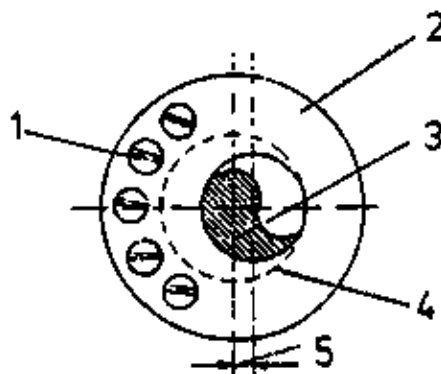
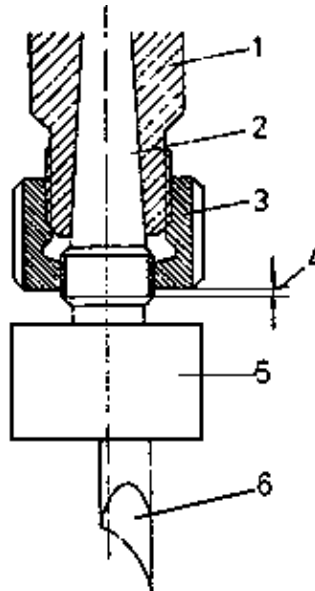

**Figure 4** – Single-edged milling tool in chuck

1 balancing screw, 2 chuck, 3 tool, 4 knife cutting circle, 5 eccentricity

Therefore, every tool clamp must be balanced jointly with the tool. For this reason tapped holes are inserted into eccentric chucks. During balancing screws are turned into these bores for the eccentrically chucked tool. The chuck is tightened in a balancing roll for balancing. The roll is then made to roll slightly on an even and thoroughly even glass plate. By altering the distribution of screws in the chuck the weight distribution is changed around until the roll remains stationary in any position. Then the chuck is sufficiently balanced.

Ensure that the chuck cone is free from grease and dust and in sound condition when the chuck is positioned in the spindle.

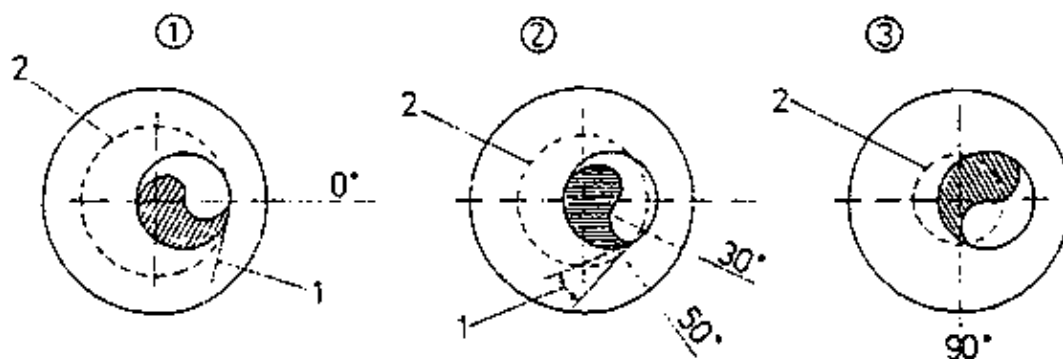

**Figure 5** – Chuck mounting to the milling spindle

*1 milling spindle, 2 cone, 3 differential nut, 4 knife cutting circle, 5 eccentricity*

The positioned chuck is tightly clamped with a differential nut which is only moderately tightened. The chuck has been correctly placed if merely two thread leads are visible below the differential nut.

The knife cutting circle can be altered on the eccentric chuck by varying the plan angle between tool cutter and the line chuck to tool axis. The mill width of the tool can thus be aligned simply to the processing job in hand.



**Figure 6** – Eccentric chucking of the routing tools (example (1), (2), (3))

*1 clearance angle, 2 knife cutting circle*

Plan angle  $\alpha = 0^\circ$  cutting possible but tool inclined to bum as no plan angle available.

Plan angle  $\alpha = 30^\circ$  to  $50^\circ$  optimal cutting conditions and best quality, knife cutting circle becomes smaller.

Plan angle  $\alpha = 90^\circ$  cutting is no longer possible as the workpiece rear face extends beyond the knife cutting circle. The cutter is not brought into play.

Staggered chuck sizes are required for chucking the various tool types. These chucks feature differing eccentricities. Consequently, however, a small number of tool suffice for setting up differing working widths.

**Table 1:** Setting table to determine the chuck sizes for cylindrical routing machines

d <sub>1</sub>	F	d <sub>2</sub> at =		d <sub>2</sub>	F	d <sub>2</sub> at =	
		50°	30°			50°	30°
2.5	0.5	2.85	3	10.5	3	12.6	13.2
2.5	1	3.2	3.4	11	3	13.2	13.8
3	1	3.7	3.9	11	4	14	14.7
3.5	1	4.2	4.4	12	4	15	15.6
4	1.5	5.1	5.3	13	4	15.9	16.9
4.5	1.5	5.6	5.9	13	5	16.8	17.8
5	1.5	6.1	6.4	14	5	17.6	18.6
5.5	2	6.9	7.35	15	5	18.6	19.4
6	2	7.4	7.75	16	5	19.4	20.4
6.5	2	8	8.4	16	6	20.4	21.4
6.5	2.5	8.5	8.85	17	6	21.4	22.4
7	2.5	8.8	9.4	18	6	22.4	23.2
7.5	2.5	9.4	9.9	19	6	23.2	24.4
8	2.5	9.9	10.4	19	7	24	25.2
8	3	10.2	10.7	20	7	25.2	26.4
8.5	3	10.6	11.2	20	8	26	27.4
9	3	11.2	11.6	22	8	27.5	29
9.5	3	11.6	12.2	22	9	28.5	30
10	3	12.2	12.6				

? = routing machine plan angle, d<sub>1</sub> = tool diameter, d<sub>2</sub> = knife cutting circle, F = chuck size

**Example:**

A milling width of d<sub>2</sub> = 20 mm is required.

Which chuck size should be selected?

Which workpiece diameter is used?

According to Table 1, when using a tool with a diameter d<sub>1</sub> = 16 mm in the chuck size F = 5, the result is a possible milling width of d<sub>2</sub> = 19.4 to 20.4 mm

Table 1 does not feature the various milling widths d<sub>2</sub>. How can the not cited value d<sub>2</sub> = 6.0 mm be calculated?

---



---



---

Centrical chucks are also used for multi-cutter tools. Balancing is not necessary with these chucks. The knife cutting circle remains constant and is not subject to change through setting measures.

### 3. Routing machine tools

The selected tool always depends on the nature of the processing operation. Single- and double-edged tools are used for milling operations with a routing machine.

Single-edged tools permit a variety of setting values and can be simply resharpened. Such tools must be clamped into an eccentric chuck, otherwise chip removal is not possible.

Double-edged tools can be clamped into an eccentric chuck. Only one tool cutter operates and, as in the case of single-edged tools, the knife cutting circle can be variously set. When using a central chuck both tool cutters operate and the knife cutting circle remains constant.

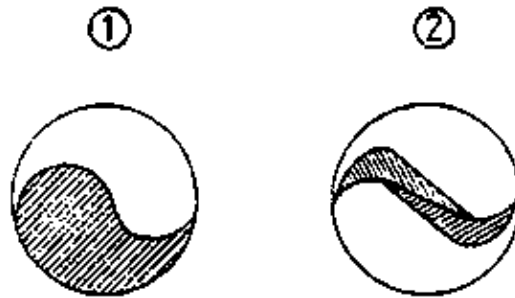

Figure 7

- (1) Single-edged tool
- (2) Double-edged tool

Tools with a taper shank or tap shaft can only be centrally chucked.

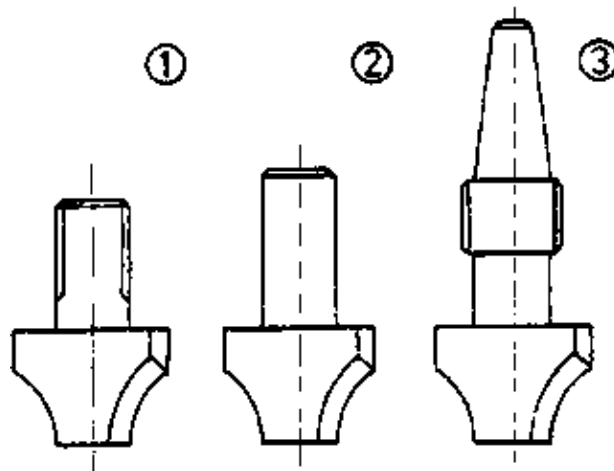

Figure 8

- (1) Tool with tap shank
- (2) Tool with cylinder shank
- (3) Tool with taper shank

Why does only one cutter operate during chip removal given the eccentric chucking of a double-edged tool?

---







---

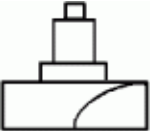

---

Table 2: Types of routing tools

Designation Presentation	Special features
--------------------------	------------------

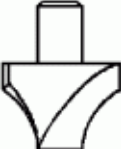
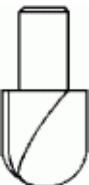
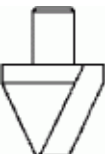
<p>cylindrical routing machine</p> 	<p>single–edged tool for eccentric chucking for milling grooves, curves, recesses and bores</p>
<p>fold cutter with tap shank</p> 	<p>double–edged tool with screw thread for central chucking only for fold milling – not for bore operations!</p>
<p>Dovetailing machine</p> 	<p>single–edged tool for eccentric chucking for yielding dovetailed comer joints</p>
<p>bun cutter</p> 	<p>single–edged tool for eccentric chucking for yielding burr joints, milling burr grooves and the burr spring</p>
<p>half round cutter</p> 	<p>single – and double – edged tool executions possible double–edged only for central chucking for milling half round profiles and narrow faces</p>
<p>quarter round cutter</p> 	<p>single–edged for eccentric chucking at a radius of up to 8 mm from 10 mm double–edged for central chucking</p>
<p>chamfer cutter</p> 	<p>double–edged for central chucking to yield chamfer grooves, half and quarter chamfers</p>
<p>grain cutter</p> 	<p>single–edged tool for eccentric chucking</p>



fold cutter with taper shank

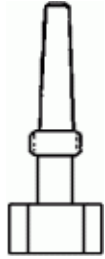

with taper shank for central chucking tool is clamped into the spindle without chuck and tightened by means of the differential nut

#### 4. Tool Guiding Possibilities

Stop strips or a stop rule can be attached to the machine table surface for tool guidance.

The table surface features tap bores to retain the holding screws for the stops. In addition, the stops can be held by means of screw clamps.

Curved models can be prepared at the locator pin. Commensurately, the locator pin can be raised at various heights above the table surface.

The tool shall not touch the locator pin. Tool and locator pin can otherwise be damaged and there is a considerable accident risk. The model only has a very small bearing surface at the locator pin and should, therefore be of particularly hard and durable material.

Special guide facilities must be prepared for milling operations with varying milling directions within the range of broad surfaces and for milling contours. Thereby, the sequence of the milled profile is determined by the sequence of the locator slot in the lower face of the guidance facility. During this process the locator pin is in the locator groove and serves as stop. The top side of the guide facility features stops and holding possibilities for the workpiece being processed.

In the Instruction Example 05.3. "Quarter Chamfer and Half Chamfer" the handling of a copying facility as guide device is described.

The following should be heeded when setting up this facility:

- the device must be easy and safe to handle
- during processing the workpiece shall not change its position in the device
- the locator pin must slide easily into the locator groove

Stops and guide strips are screwed, glued or nailed to the base plate.

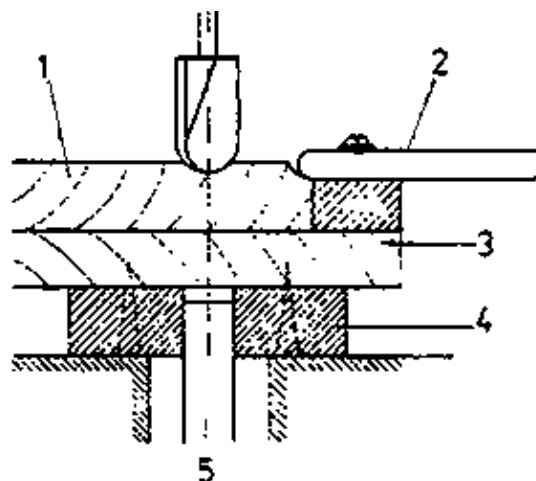
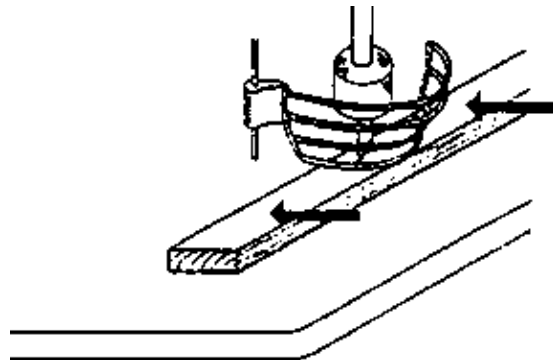

Figure 9 – Cross-section of a copying device

## 5. Basic Provisions of Labour Safety when Operating Routing Machines

The routing machine is a wood working machine giving rise to the lowest number of accidents. The required labour safety provisions can be easily ensured. The requirements in point are the following:

- order and tidiness around the machine are essential preconditions for accident-free operations
- the tool spindle must glide automatically into the top rest position during boring operations. This process ensues through the compensating mass
- the tool spindle must be capable of arrest at the highest position during milling operations. This requirement is met with the help of a retainer pin at the spindle guide. By means of removal and turning through 90° the pin no longer operates. This is necessary when switching to drilling operations
- the tool must evidence its highest setting within the protective device, the guard basket
- the guard basket must prevent the hands from touching the workpiece
- only use sharp tools. Blunt tools can cause accidents
- copying devices must include chucking elements for workpiece clamping. Handle grips are required
- persons with long hair must do on a head covering
- finger rings must be removed prior to commencing work operations



**Figure 10** – Guard basket for operations on the routing machine