

**Ripping and Mortising – Course: Manual woodworking techniques.
Instruction examples for practical vocational training**

Table of Contents

<u>Ripping and Mortising – Course: Manual woodworking techniques. Instruction examples for practical vocational training</u>	1
<u>Preliminary Remarks</u>	1
<u>Instruction Example 6.1.: Recess</u>	1
<u>Instruction Example 6.2.: Slot Hole and Dovetail Hole</u>	3
<u>Instruction Example 6.3.: Mortise</u>	7

Ripping and Mortising – Course: Manual woodworking techniques. Instruction examples for practical vocational training

**Institut für berufliche Entwicklung e.V.
Berlin**

Original title:
Lehrbeispiele für die berufspraktische Ausbildung
“Stemmen und Stechen”

Author: Rolf Jakoby

First edition © IBE

Institut für berufliche Entwicklung e.V.
Parkstraße 23
13187 Berlin

Order No.: 93–33–3306/2

Preliminary Remarks

The present material includes 3 selected instruction examples by means of which the trainee is able to acquire fundamental knowledge and skills in the working techniques of mortising and ripping. These training examples are arranged so that the trainee can learn the handling and correct application of the tools in performing different mortising and ripping operations for manufacturing of wood joints.

This work also includes sharpening of the mortising and ripping tools if the tools' condition should make this necessary.

Knowledge and skills already acquired for sharpening of plane irons from the training course of “Planing” should be applied for this purpose.

For each instruction example, the necessary materials, tools, measuring and testing means and auxiliary accessories are specified to facilitate the preparation and execution of the work.

Furthermore, the previous knowledge is given that is required to work the workpieces and should be incorporated into the exercises for recapitulation.

The sequence of operations specified for each instruction example includes working steps leading to the acquisition of the working technique and the manufacture of the connecting element for the relevant workpiece.

Technical particularities and the achievement of quality features are specifically mentioned.

A working drawing is attached to each instruction example showing the required shape and the dimensions of the practising piece and of the connecting element to be mortised.

In case of a further application of the connecting elements and practising pieces for useful products the required dimensions are decided at the instructor's discretion.

Instruction Example 6.1.: Recess

[...]

Sequence of operations

Comments

- | | |
|---|--|
| 1. Check and prepare the tools, adjust the carpenter's bench. | Check sharpness of the mortising and ripping tools; pay attention to store the tools properly and safely! |
| 2. Scribe the recess on the workpiece according to the given dimensions. | For scribing the depth use a marking gauge. |
| 3. Clamp the workpiece in the carpenter's bench. | The scribed width face is on top. |
| 4. Give a cut with the saw along the measure lines up to the scribed working depth. | |
| 5. Chisel out wood chips

– by driving in the firmer chisel from the centre of the recess with the grain at an acute angle to the wide face,

– splitting off the wood chips by bending the firmer chisel backwards and down. | Tilt the cutting edge of the blade of the firmer chisel slightly upward; recess the entire width and depth of the workpiece in sections; pay attention to the working depth, cut the thin wood chips last. |
| 6. Work in the opposite direction (see operation No. 5). | |
| 7. Flatten and smooth the prechiselled surface; ensure the exact dimensional stability by re-working with the ripping chisel diagonally and across the grain. | The cutting edge of the ripping chisel blade should be pointed at the working face of the workpiece; guide the ripping chisel just up to the centre of the surface to avoid fraying of wood fibres. |
| 8. Check the dimensional stability and the flatness of the chiselled surface. | Half of the scribed line should be visible; the surface must not be splintered; lay a straightedge across and diagonally on the surface and compare. |
| 9. If necessary, sharpen the mortising and ripping tools. | |

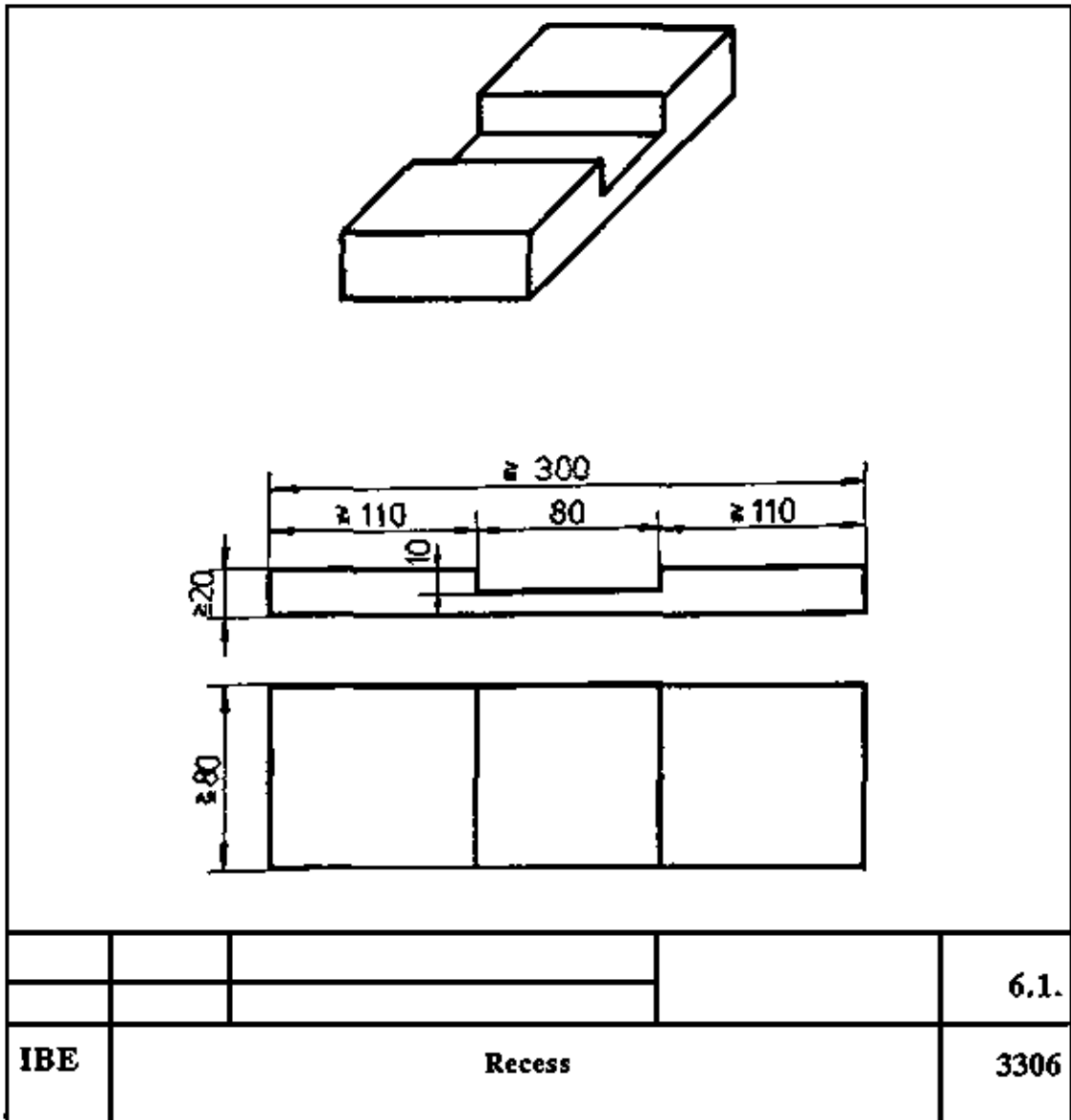

Instruction Example 6.2.: Slot Hole and Dovetail Hole

Mortising of through recesses at the edge of a workpiece to be practised on planed boards or strips.

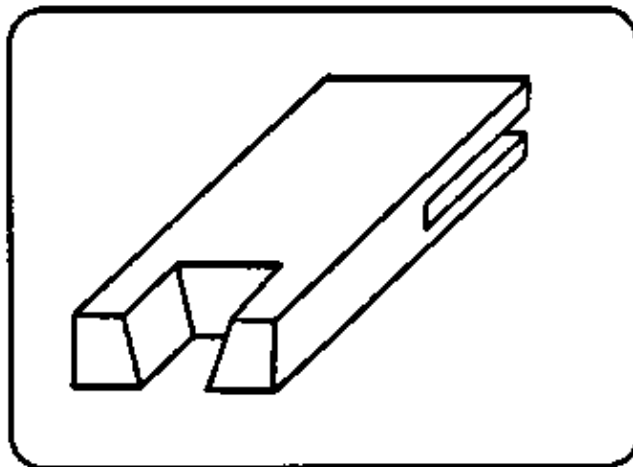

Material

Planed boards or strips, end-grained narrow faces worked rectangularly

Width: not less than 60 mm

Length: not less than 250 mm

Thickness: not less than 20 mm

Tools

Frame saw, ripping chisels of different width, hard wood or hard rubber mallet, marking gauge

Measuring and testing means

Folding rule or measuring tape, protractor, sliding square (bevel)

Auxiliary

Carpenter's bench, screw clamp, packing wood, tool grinder, whetstone, stoning fluid, pencil

Necessary previous knowledge

Reading of drawings, measuring, scribing, sawing, testing, sharpening of tools

Explanations to the working drawing

? – equal to or greater than

Sequence of operations – slot

Comments

- | | | |
|----|--|--|
| 1. | Check and prepare the tools. | |
| 2. | Scribe the length and thickness of the slot on the workpiece according to the given dimensions. | Use a rule and a marking gauge. |
| 3. | Clamp the workpiece in the carpenter's bench. | The scribed end-grained narrow face is on top |
| 4. | Give a cut with the saw close to the scribed lines parallel the grain up to the transverse limiting lines. | Guide the saw along the halves of the scribed lines towards the face to be chiselled out. |
| 5. | Clamp the workpiece – with the longitudinal narrow face on top – on the plate of the carpenter's bench. | The screw clamp should fasten the packing wood, the workpiece and the plate of the carpenter's bench as a whole. |
| 6. | Precut the transverse limiting line with the ripping chisel between the edges cut by saw. | One hand takes the ripping chisel blade; do not guide the ripping chisel at its full width, lilt it slightly when pulling. |
| 7. | Recess the slot hole by | |

The cutting edge of the ripping chisel blade should be pointed at the transverse limiting line.

- driving in the ripping chisel
 - at the precut transverse limiting line, vertically, across the grain,
 - at a small distance from it and diagonally to the grain.

First cut off thin chips only.

– enlarging the funnel-shaped recess up to half the width of the workpiece and up to about 2/3 of the slot length.

8. Reclamp the workpiece with the longitudinal narrow face on top.

9. Cut through the slot hole – according to the operations Nos. 6 and 7 and by driving in the ripping chisel into the end-grained narrow face with the grain.

First chisel out the funnel-shaped recess, then cut off the wood fibres across the grain and finally split them off in longitudinal direction. Caution when mortising the last central wood layers in order not to damage the opposite slot edges!

10. Check the mortised slot edges for straightness and flatness.

Hold a thin straight strip fitting the slot hole (use a side of the try square) against the surface and compare; slot edges and test surface must be snugly fitting on each side.

Sequence of operations – dovetail hole

Comments

1. Scribe the length of the dovetail hole on the opposite wide faces of the workpiece according to the given dimensions.

Use a marking gauge and place it on the narrow face of the cross-grained wood.

2. Clamp the workpiece in the carpenter's bench with the narrow face of the cross-grained wood on top.

3. Scribe the width and the bevel of the hole both on the narrow and wide end-grained faces.

For scribing the bevels use a sliding square (bevel).

4. Give a cut with the saw at the marked lines up to the limiting transverse lines.

Guide the saw acc. to operation No. 4 (making slots)!

5. Fasten the workpiece with a screw clamp on the plate of the carpenter's bench with the wide face on top.

6. Precut the limiting transverse line acc. to operation No. 6 (making a slot hole).
7. Recess the dovetail hole by
- driving in the ripping chisel at
 - the precut transverse limiting line, vertically, across the grain;
 - at a small distance from it and diagonally to the grain.
 - Reclamp the workpiece, with the opposite longitudinal narrow face being on top.
 - Cut through the dovetail hole (acc. to the operations Nos. 6 and 7 – making slots).
8. Check the quality of the mortised dovetail edges (according to the sequence of operations) for flatness.
9. Sharpen the ripping and mortising tools, if necessary.
- Use a ripping chisel of medium or greater width;
- when driving in the ripping chisel across the grain, hold its blade in parallel to the edges cut by saw.
- First cut off thin chips only.

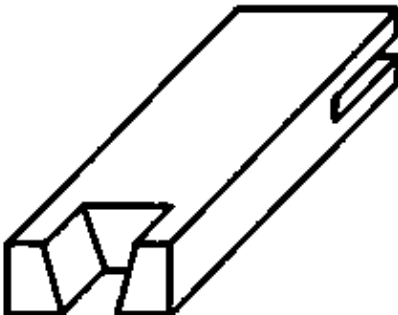
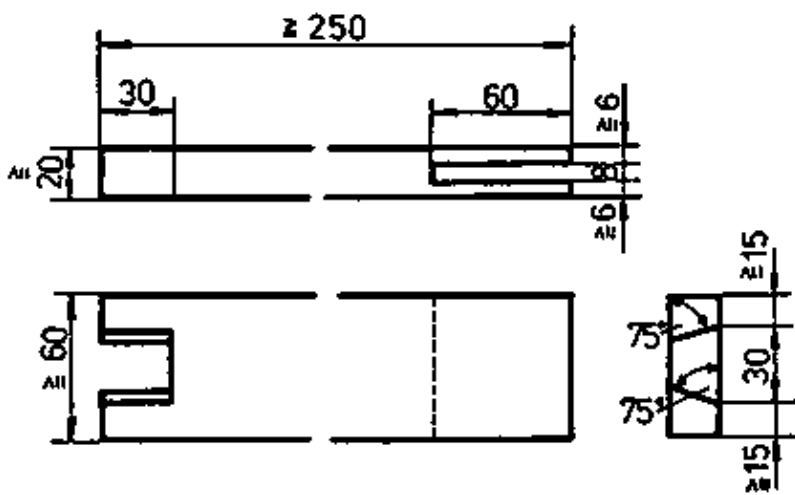
			
			
			6.2.
IBE	Slot Hole and Dovetail Hole		3306

Instruction Example 6.3.: Mortise

Making continuous conical mortises to be practised on planed boards.

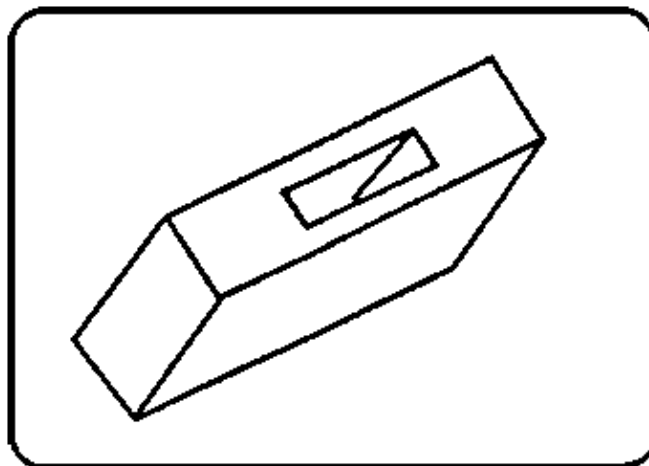

Material

Planed boards

Width: 80 mm

Length: not less than 250 mm

Thickness: not less than 35 mm

Tools

Ripping chisel of larger width, cross-cut or firmer chisel (10 mm to 12 mm wide), hard wood or hard rubber mallet, marking gauge, scribe

Measuring and testing means

Folding rule or measuring tape, try square 90°

Auxiliary accessories

Carpenter's bench, tool grinder, whetstone and stoning fluids, pencil

Necessary previous

Reading of drawings, measuring, scribing, checking, sharpening tools

Explanations to the working drawing

? – equal to or greater than

Sequence of operations	Comments
1. Check and prepare the tools.	For proper guidance of the chisel during mortising mark out the length and the bevel of the mortise with pencil strokes on one wide face.
2. Scribe the length, thickness and bevels of the mortise on the workpiece acc. to the given dimensions.	
3. Clamp the workpiece in the carpenter's bench.	The longitudinal narrow face with shorter mortise edges (to be chiselled rectangularly) is on top.
4. Chisel a notch in the centre of the mortise diagonally to the wood grain and enlarge it up to some millimeters close by the limiting transverse lines.	Use a firmer or ripping chisel the width of which is approx. 2 mm less than thickness of the mortise; the cutting edge of the blade of the firmer (ripping) chisel should be alternately tilted upwards and pointed at the mortise centre; guide the chisel in parallel to the wide face of the workpiece!
5. Drive in the firmer chisel (cross-cut chisel) at the opposite limiting lines, vertically, across the grain.	The cutting edge of the chisel blade must be pointed at the transverse scribed line; drive in the chisel blade true to the scribed line and at an angle of 90° to the narrow face of the workpiece as well as in parallel to the wide faces.

- | | | |
|-----|--|---|
| 6. | Split off the wood chips by driving in the firmer chisel | Guide the channel of the chisel in parallel to the grain. |
| 7. | Deepen the mortise approx. up to half the width of the workpiece acc. to the operations Nos. 5 and 6. | |
| 8. | Finish up the opposite wide faces of the mortise by accurately guiding the ripping chisel along the scribed lines, in parallel to the workpiece wide faces, up to the pre-chiselled depth. | Use a wide chisel; the cutting edge of the chisel blade is pointed at the wide face of the mortise to be produced. |
| 9. | Reclamp the workpiece with the opposite narrow face on top. | |
| 10. | Prechisel the mortise acc. to operation No. 4. | |
| 11. | Drive in the firmer chisel (mortise chisel) at the opposite limiting lines, diagonally to the grain, acc. to the diagonal scribed lines on the wide face of the workpiece. | Guide the chisel acc. to operation No. 5 (with the exception of the angular guidance of the blade). |
| 12. | Cut through the mortise acc. to the operations Nos. 6 to 8. | |
| 13. | Check the inner surfaces of the mortise for dimensional accuracy and flatness. | Use a straight strip fitting into the mortise (use a side of the try square, if available), place it on the faces and compare; the faces of the mortise and those of the testing device must be snugly fitting on each other. |
| 14. | Sharpen the ripping and mortising tools, if necessary. | |

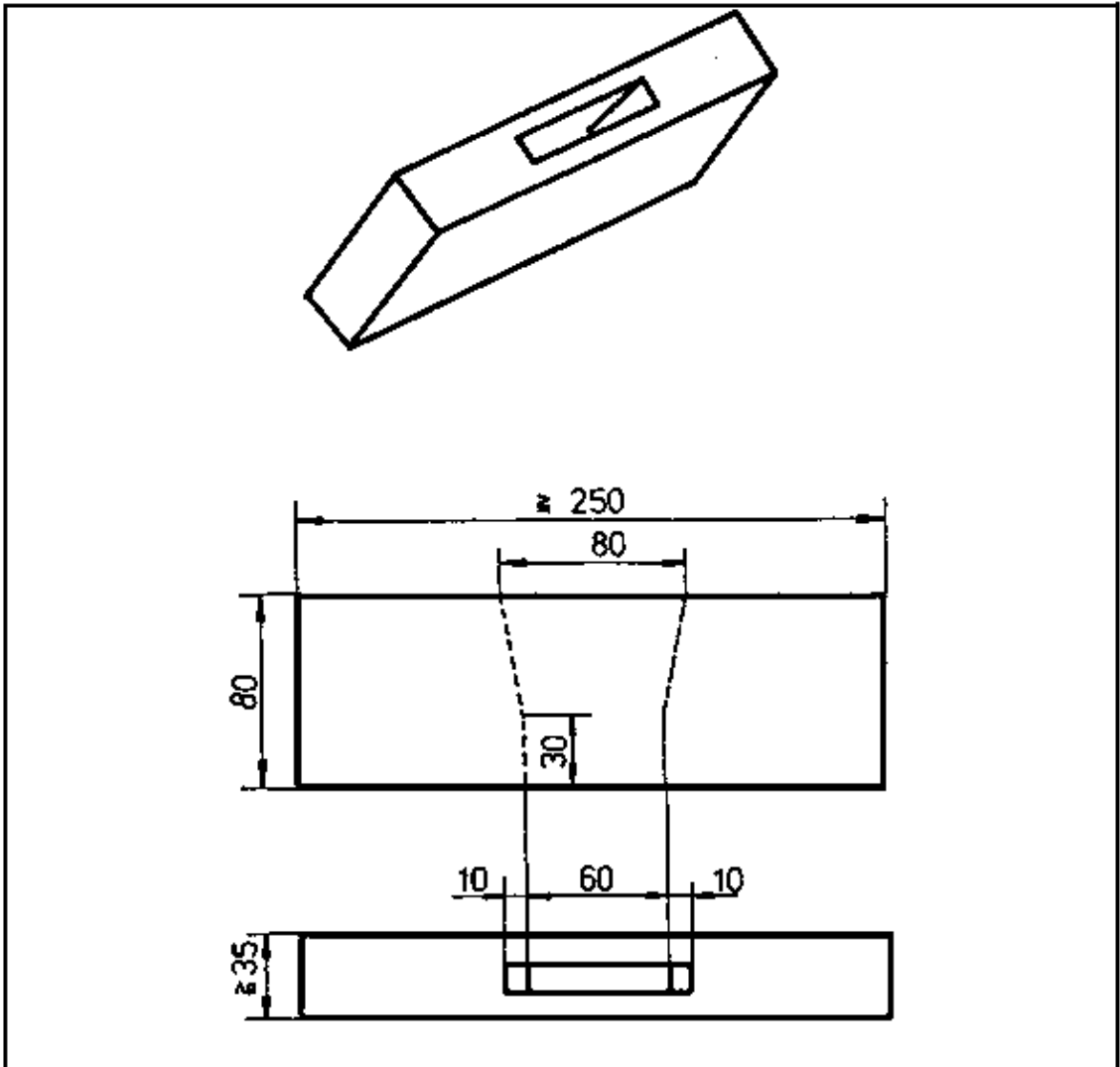

				6.3.
IBE	Mortise			3306