

Making of Roof Flashing – Course: Timberwork techniques. Instruction examples for practical vocational training

Table of Contents

<u>Making of Roof Flashing – Course: Timberwork techniques. Instruction examples for practical vocational training</u>	1
<u>Preliminary Remarks</u>	1
<u>Instruction Example 3.1.: Working of Boards for a Roof Base Facing</u>	1
<u>Instruction Example 3.2.: Making of a Roof Base Facing</u>	6
<u>Instruction Example 3.3.: Template Making for a Rafter Foot</u>	10
<u>Instruction Example 3.4.: Re-proofing of Buildings</u>	14

Making of Roof Flashing – Course: Timberwork techniques. Instruction examples for practical vocational training

**Institut für berufliche Entwicklung e.V.
Berlin**

Original title:

Lehrbeispiele für die berufspraktische Ausbildung
"Herstellen von Dachüberständen"

Author: Rolf Becher

First Edition © IBE

Institut für berufliche Entwicklung e.V.
Parkstraße 21–23
13187 Berlin

Order No.: 93–33–3603/2

Preliminary Remarks

The present booklet contains 4 selected instruction examples which are exclusively related to eaves flashings. Making of eaves flashings requires work on site and in the workshop as well.

The Instruction Examples 3.1. and 3.2. have been selected so that practising of the examples can be done separately or successively, one based on the other one.

Instruction Example 3.3. includes the calculations necessary for making the templates required for an eaves flashing to be made on a roof structure to be built.

Example 3.4. explains the sequence of operations in template making for re-proofing of buildings.

The necessary materials, machines, hand tools, measuring and testing means and auxiliary accessories are specified for each example to facilitate the preparation and execution of the work. Moreover, the previous knowledge, which is necessary in addition to knowledge of the technique Making of Roof Flashings, is also stated for each example and should be recapitulated at the beginning.

The order of working steps given in the sequence of operations is to be followed, in order to achieve good quality of work.

A working drawing showing the required shapes and dimensions is also attached to each example.

The working drawings 3.1. and 3.2. are required for the first two examples.

Instruction Example 3.1.: Working of Boards for a Roof Base Facing

The face and bottom boards for a couple roof base facing are to be worked.

Material

Boards with tongue and groove planed on one side, board lengths between 3000 mm and 4100 mm

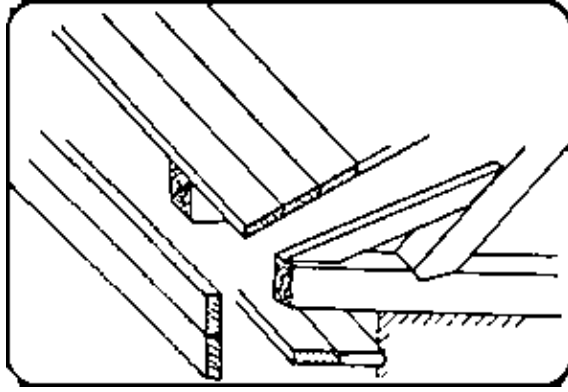

Hand tools and machines

Smoothing plane, circular saw bench

Measuring and testing means

Folding rule, measuring tape (if necessary)

Auxiliary accessories

Pencil, work bench (working table)

Necessary previous knowledge

Reading of drawings, measuring and testing, planing, operation of the circular sawing machine, fundamental arithmetic operations

Sequence of operations

1. Determine the board length.
 – 4100 mm long boards cover 5 bays
 $5 \cdot 803 \text{ mm} = 4015 \text{ mm}$

– 20 bays would be 4 board lengths
 $4 \cdot 4015 \text{ mm} = 16060 \text{ mm}$.

– Initial board

$$3 \cdot 803 \text{ mm} + \frac{160 \text{ mm}}{2} + 20 \text{ mm}$$

365 mm = 2874 mm
 Length selected: 3000 mm

– Intermediate board $5 \cdot 803 \text{ mm} = 4015 \text{ mm}$
 Length selected: 4100 mm

$$\text{Final board } 2 \cdot 803 \text{ mm} + \frac{160 \text{ mm}}{2} +$$

–
 $20 \text{ mm} + 365 \text{ mm} = 2071 \text{ mm}$
 Length selected: 3000 mm

2. Determine the board width.
 – Lay out eaves flashing in scale 1:1, determine and measure the width:
 face boards: 120 mm width
 bottom boards: 130 mm width

Comments

Use attic framing drawing!

Roof base facing must cover the total length of the building.
 Length of building = 16990 mm.
 4 board lengths are not feasible!

Use attic framing drawing!
 Initial board over 3 bays. Beam distance from centre to centre!

over 5 bays,
 three joints = 15 bays

over 2 bays, since $3 + 15 + 2 = 20$ bays
 The difference of 929 mm is required for closing the roof base facing.

Consider maximum board width.
 See drawing of Instruction Example 3.2.
 Add about 10 mm for tongue and groove to be cut off.

3. Determine the number of boards.

- Face boards: 120 mm wide
2 • 2 = 4 boards 3000 mm long
3 • 2 = 6 boards 4100 mm long

- Bottom boards: 130 mm wide
2 • 2 = 4 boards 3000 mm long
3 • 2 = 6 boards 4100 mm long

– List of boards:

- 8 boards of 3.0 m length and 12 cm width
- 12 boards of 4.1 m length and 12 cm width
- 8 boards of 3.0 m length and 13 cm width
- 12 boards of 4.1 m length and 13 cm width.

4. Select boards of adequate length and width in timber yard.

5. Store boards according to width at the side of the circular saw bench.

6. Saw boards to width.

Board (1) 120 mm

Board (2) 120 mm + tongue length

Board (3) 111 mm + tongue length

Board (4) 110 mm

7. Chamfer boards

- Chamfer boards (1) and (4) at the groove side.
- Chamfer board (2) at the tongue side.
- Chamfer board (3) at three sides and smooth visible projection.

8. Store boards for transportation.

Use laid-out eaves flashing and determination of step 1 above.

Roof base facing is to be provided at both sides of the couple roof.

Consider surface quality, too!

Make sure that there is enough freedom to move!

Use laid-out eaves flashing.

(See drawing of Instruction Example 3.2.).

Think of tongue length.

Use stop at circular saw bench!

1 mm on board 3 is needed for smoothing of the surface.

(See drawing of Instruction Example 3.2.)

Put board flat on work bench.

Maximum chamfer 3 mm. Planed side to be on top.

Clamp board edgewise on work bench and plane off to 110 mm. Lay board flat and chamfer at tongue and groove sides.

Turn board over (rough side on top) and smooth visible areas.

Protect stored boards against possible damage during storage!

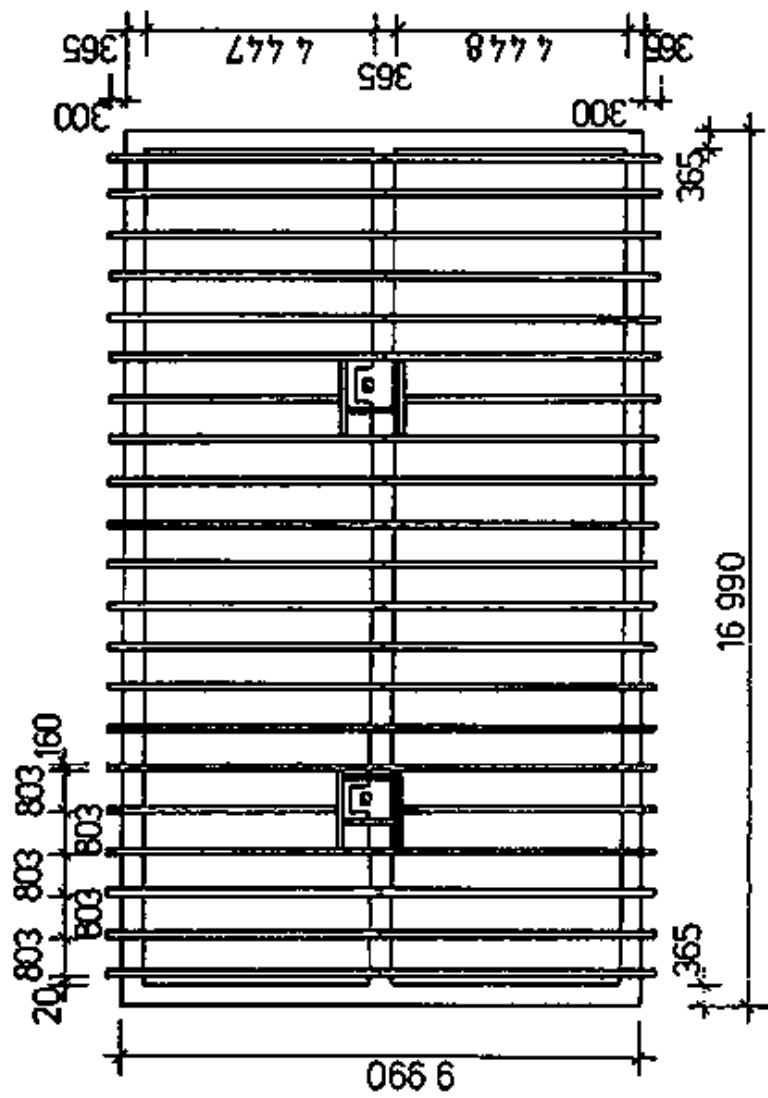

				3.1.
IBE	Attic Framing			3603

Instruction Example 3.2.: Making of a Roof Base Facing

The wooden beam heads projecting by 300 mm are to be covered by a roof base facing.

Material

Prepared face and bottom boards

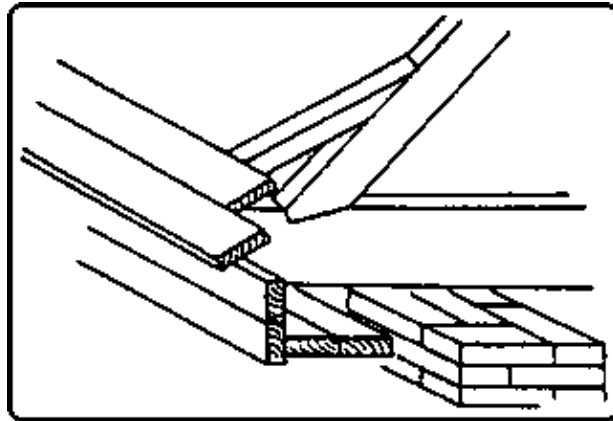

Hand tools

Hammer, frame saw, wrecking bar with claw, nail punch

Measuring and testing means

Folding rule, bevel protractor

Auxiliary accessories

Pencil, measuring rod 4015 mm long, cleat, nails 3.1/80, 2.8/70

Necessary previous knowledge

Reading of drawings, measuring and testing, sawing, scribing, nailing, nail punching.

Sequence of operations

1. Check the scaffolding.
2. Store boards on scaffolding.
Store face and bottom board, as well as different lengths separately.
3. Cut square initial board (1) at right end.
4. Place and fasten provisionally board (1).

Comments

Working direction from left to right.
Stability, bracing, covering of uprights, guard rail.

Ensure freedom of movement!

Use try square.
Saw off only as much as necessary to produce a square section.

Place right end of board centrally at 4th beam head.
Place cleat as stop at cross-grained end of beam head.
Fasten board provisionally on beam heads 1 and 3.
Use nails 2.8/70. Drive nails in only as deep as to

- | | |
|--|--|
| 5. Scribe initial board. | permit their removal later on! |
| 6. Take off initial board and scribe angular line. | Align over gable wall and scribe–mark.
Use a try square.
Don't remove provisionally fastened nails!
(Nail holes in beam heads and nails in board guarantee exact fit!) |
| 7. Saw initial board to length. | Saw square! |
| 8. Place measuring rod at initial board (1) and transfer size. | Do it exactly! |
| 9. Nail initial board (1). | Locate points of nails in the board in nail holes in the beam head and drive in the nails.
Do not completely drive in the nail at the groove side of the board to permit insertion of the tongue of board (2). |
| 10. Scribe and saw to length initial boards (2), (3) and (4). | Measuring rod to be placed flush.
Use try square.
Saw exactly square! |
| 11. Nail initial board (2). | Insert tongue in groove of board (1) and press it in with lever pressure.
Place cleat at plasterwork. Exert gentle pressure with wrecking bar.
Drive in two 2.8/70 nails per beam head.
Make sure it is flush with board (1). |
| 12. Nail initial boards (3) and (4). | Insert tongue in groove of boards and place boards.
Set marking gauge for projection (15 mm) and adjust board (3).
Make sure it is flush with board (1).
Drive in two 3.1/80 nails per beam head. |
| 13. Place measuring rod of 4015 mm length over the next beam heads and check the size. | Place it from centre to centre of beam heads.
Check over the entire facade. |
| 14. Scribe and saw to length all four boards for the other joints of the roof base facing according to the checked size. | Use a try square.
Saw exactly square. |
| 15. Nail roof base facing boards. | Nail the boards joint by joint proceeding similarly as with the first joint (initial boards). |
| 16. Saw square at left end and fasten provisionally final board (1). | Use a try square.
Do not drive in nails completely. |
| 17. Scribe length of board. | Align over gable wall and scribe size. |
| 18. Take off, scribe and saw to length final board (1). | Use a try square. |
| 19. Place measuring rod at final board and transfer length. | Place flush at one end.
Place measuring rod parallel. |
| 20. Scribe and saw to length final boards (2), (3) and (4) according to size taken. | Place measuring rod exactly.
Use a try square.
Do not let the cuttings break off when sawing off!
(Cuttings are to be used for closing the roof base facing) |
| 21. Nail final boards. | 09 Consider type of nails! |
| 22. Close roof base facing at both ends. | |

Use the cuttings.
Place, scribe, saw and insert the board pieces individually.
Use 2.8/70 nails.

23. Nail the roof base facing.

Nail in the centre of the beam bays
– through board (3) in board (1)
– through eaves board in board (4).
Use 2.8/70 nails.

24. Clean the work place.

Pick up wooden cuttings and clean scaffolding.

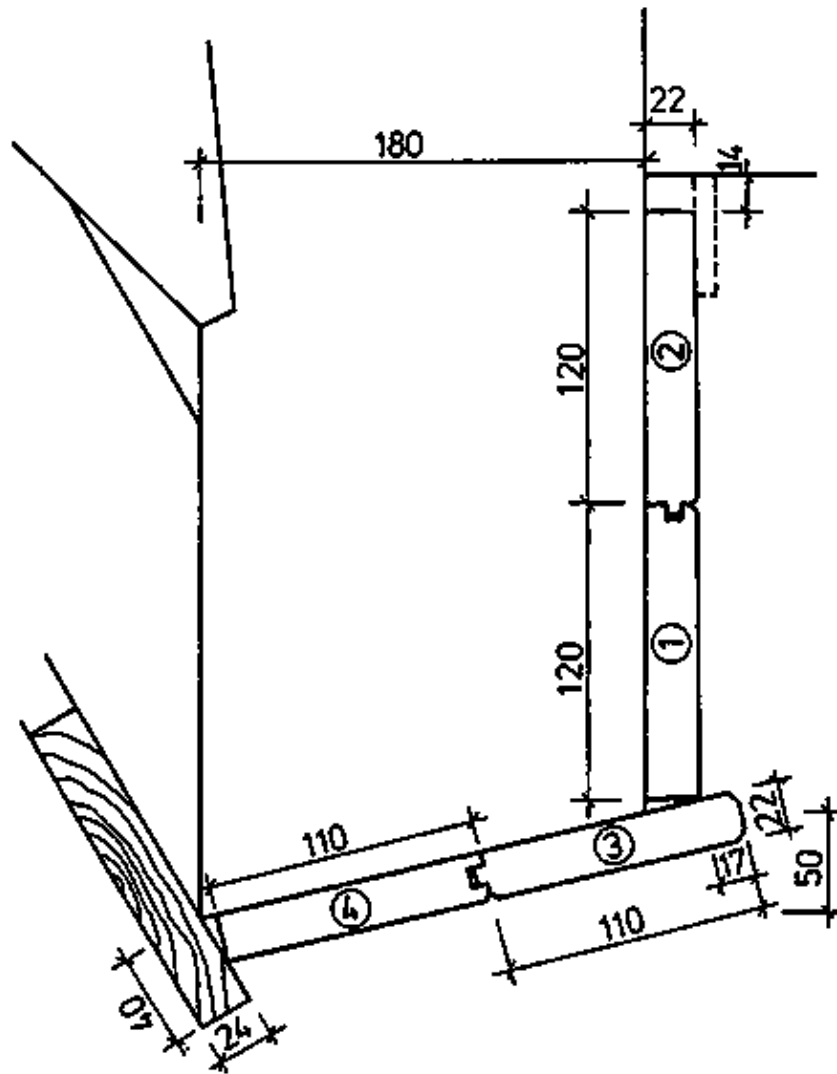

				3.2.
IBE	Eaves Flashing			3603

Instruction Example 3.3.: Template Making for a Rafter Foot

The template for the rafter foot of a purlin roof to be built shall be made and the real rafter length be determined.

Dimensions

Width of building: 8000 mm

Height of roof: 3000 mm

Cross section of rafter: 80/140 mm²

z (horizontal distance of eaves flashing) = 500 mm

n (height of inferior purlin above surface of attic beam) = 80 mm

o (square attachment timber) = 100 mm

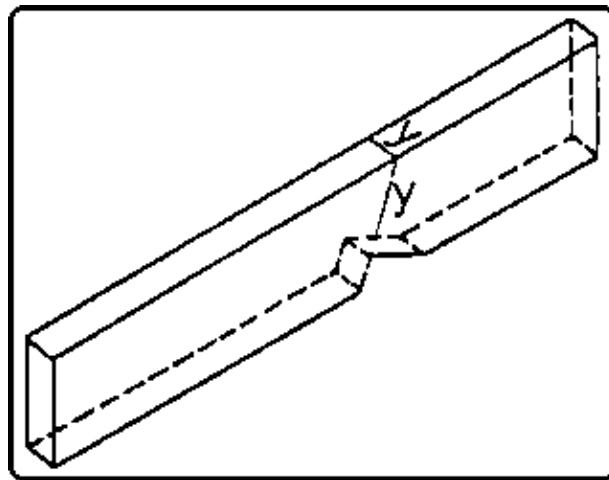

Hand tools

Frame saw

Measuring and testing means

Folding rule, carpenter's steel square

Auxiliary accessories

Paper, pencil, hand sketch, abrasive paper, board approx. 1600 mm long and 140 mm wide

Necessary previous knowledge

Reading of drawings, measuring and testing, scribing, sawing, smoothing

Sequence of operations

1. Determine real rafter length.

Req.: Spl

Known: $Spl_R = b^2 + h^2$

$$y = \frac{Spl_R \cdot z}{b}$$

Comments

Formula: $Spl = Spl_R + y$
(See also Fig. 16 in "Trainees' Handbook of Lessons")

$$y = \frac{8000\text{mm}}{2} = 4000\text{mm}$$

$$h = 3000 \text{ mm}$$

$$z = 500 \text{ mm}$$

$$\text{Spl}_R = (4^2 + 3^2) \text{ m}^2$$

$$\text{Spl}_R = 5000 \text{ mm}$$

$$y = \frac{5000\text{mm} \cdot 500\text{mm}}{4000\text{mm}}$$

$$y = 625 \text{ mm}$$

$$\text{Spl} = 5000 \text{ mm} + 625 \text{ mm}$$

$$\text{Spl} = 5625 \text{ mm}$$

2. Determine x_0

Req.: x_0

Known: $\text{Spl}_R = 5000 \text{ mm}$

$z = 500 \text{ mm}$

$$z_1 = \frac{b(y_1 + n)}{h}$$

$$b = 4000 \text{ mm}$$

$$y_1 = \frac{\text{Spl}_R \cdot o}{b}$$

$$n = 80 \text{ mm}$$

$$h = 3000 \text{ mm}$$

$$o = 100 \text{ mm}$$

$$y_1 = \frac{5000\text{mm} \cdot 100\text{mm}}{4000\text{mm}}$$

$$y_1 = 125 \text{ mm}$$

$$z_1 = \frac{4000\text{mm}(125\text{mm} + 80\text{mm})}{3000\text{mm}}$$

$$z_1 = 273.3 \text{ mm}$$

$$x_0 = \frac{5000\text{mm}(500\text{mm} + 273.3\text{mm})}{4000\text{mm}}$$

$$x_0 = 966.6 \text{ mm}$$

3. Put straight board of approx. 1600 mm length on work bench.

x_0 is the size from the inferior purlin line up to the rafter foot, **not the length for the template!**

(See also Fig. 16 in "Trainees' Handbook of Lessons")

Formula:

$$x_0 = \frac{\text{Spl}_R(z + z_1)}{b}$$

Board width to comply exactly with rafter height.

- | | |
|--|---|
| 4. Scribe angular line at left end and mark with section mark. | Use steel square.
Go to the right only as far as to produce a square cut. |
| 5. Measure in and mark the size x_0 from the angular line. | Scribe only thin and short line. |
| 6. Measure in and scribe square attachment timber. | Do not scribe over the entire length but only scribe thin line in the area of the rafter foot line. |
| 7. Mark the size y_1 on the long leg of the square. | Scribe thin line.
Mark it at the outside of the square. |
| 8. Place square with marked size y_1 at x_0 mark and swivel the square until point of intersection with square attachment timber is reached. | Place it exactly! |
| 9. Scribe surface of inferior purlin and front face of inferior purlin. | Scribe a thicker line at the short leg of the square and a thin line at the long leg. |
| 10. Scribe front face of inferior purlin. | Place long leg of square at thin line and scribe bird's mouth depth. |
| 11. Scribe template length. | Measure from x_0 line. Use a square.
Use maximum length but at least 500 mm! |
| 12. Saw out template. | Saw exactly and perfectly square.
Special care is required for sawing the bird's mouth! |
| 13. Smooth cut surfaces with abrasive paper. | Use fine-grained abrasive paper!
Smooth very gently – no chamfers must be produced! |
| 14. Transfer scribed lines of bird's mouth to upper narrow side of template. | Scribe thin line. |

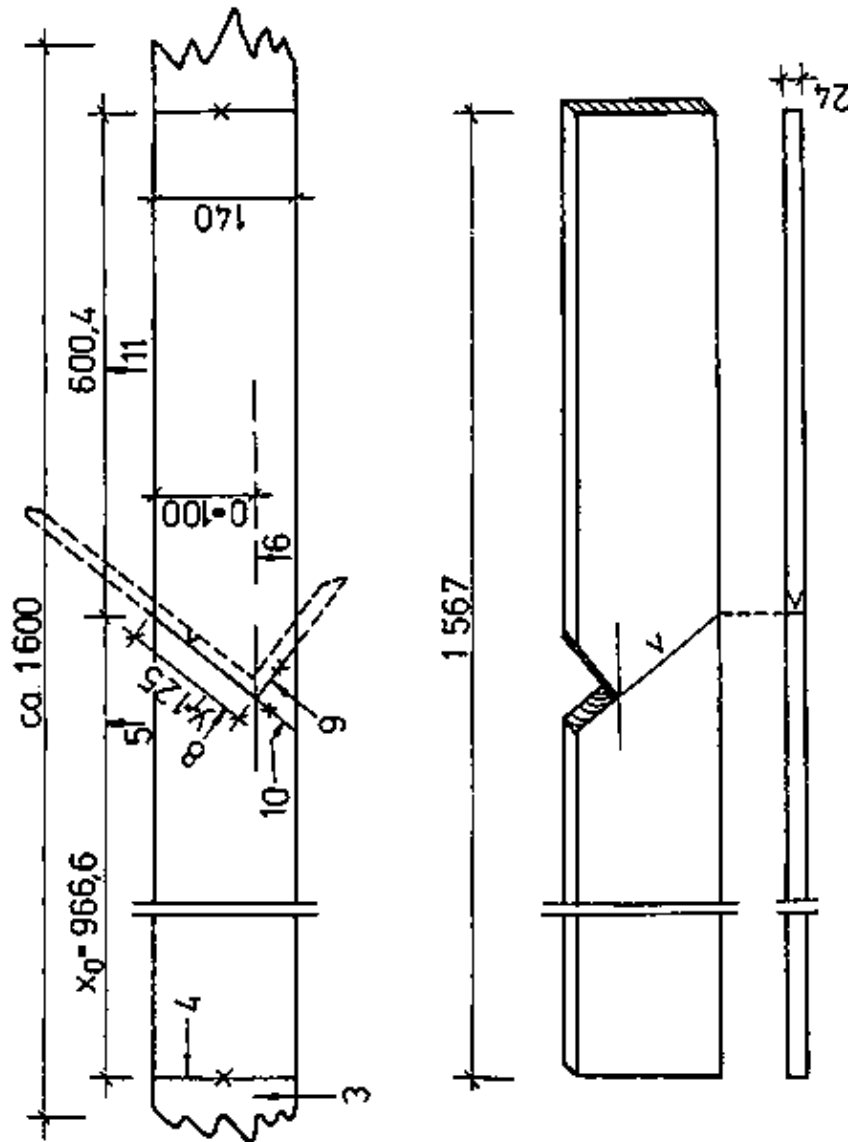

				3.3.
IBE	Template for a Rafter Foot			3603

Instruction Example 3.4.: Re-roofing of Buildings

The cover straps shall be produced for re-roofing a building by displacement of the rafter foot of a purlin roof.

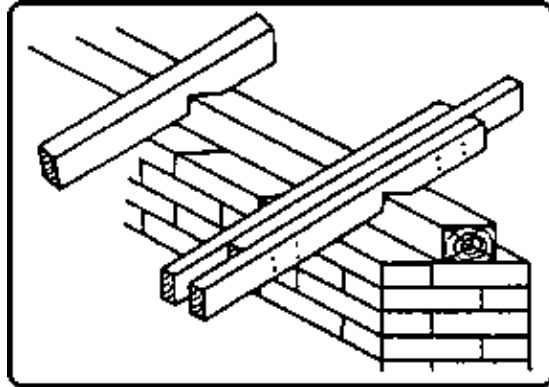

Dimensions

Cross section of roof rafter: 80/140 mm²
Thickness of cover straps: 40 mm
Horizontal distance of eaves flashing: 500 mm

Hand tools and machines

Frame saw, hand plane, bevel protractor, band saw

Measuring and testing means

Folding rule, carpenter's steel square, water level

Auxiliary accessories

Straightedge 2000 mm long, pencil, abrasive paper, board of 140 mm width and 2000 mm length

Necessary previous knowledge

Reading of drawings, measuring and testing, plumbing (perpendicularity), scribing, sawing, curving, planing, smoothing

- (1) scribed straightedge
- (2) board for template
- (3) curve of rafter foot

Sequence of operations

Steps 1 to 6 are to be carried out at the building!

1. Check the scaffolding.
2. Insert the straightedge between the roof boards and the inferior purlin and press it against the roof rafter.
3. Transfer the front face of the outside wall onto the straightedge by scribing the perpendicular line.

Comments

- Stability, bracing, covering of uprights, guard rail.
- Insert it approx. 1000 mm. Make sure that it contacts the roof boards and the roof rafter.
- Use a water level.
Check changing of water level. Mark

	scribing perpendicular line with "PERPENDICULAR".
4. Transfer front face of inferior purlin onto straightedge.	Mark only!
5. Remove straightedge and insert it at several roof rafters to check the scribed lines.	
6. Count the roof rafters.	Is necessary for the number of cover straps required.
All other steps are to be carried out in the workshop	
7. Take perpendicular line from straightedge by means of bevel protractor.	Working direction from left to right! Set bevel protractor tongue exactly and firmly tighten the wing nut!
8. Put board for template (approx. 2 m long) on work bench and scribe on it square attachment timber.	Scribe a thin line.
9. Scribe angular line at right end of board and mark the section to be cut off.	Go only as far as necessary to produce a rectangular cut.
10. Measure in and mark 500 mm from angular line to the left.	Measure on 8.
11. Scribe perpendicular line through marking.	Use bevel protractor. Perpendicular line is front face of inferior purlin.
12. Scribe surface of inferior purlin.	Place square leg at perpendicular line so as to have point of intersection with 8.!
13. Take from straightedge, measure in on template and mark the size up to front face of outside wall.	Measure on 8.! Mark only!
14. Scribe perpendicular line through marking and mark with "FW".	"FW" means front face of outside wall.
15. Mark horizontal distance of eaves flashing (500 mm) at long leg of square.	Apply only thin marking.
16. Place tongue of bevel protractor at perpendicular line, displace short leg of square at tongue so as to have point of intersection at upper edge of template board!	Place square and bevel protractor tongue exactly. Do not squeeze the tongue of the bevel protractor! Apply only thin marking.
17. Scribe template length and mark the section to be cut off.	Use a square.
18. Profiling.	Scribe the curve so that it can be easily sawn out with the band saw!
19. Saw out the template.	Saw it out at exact angles.
20. Smooth the template with abrasive paper.	Use fine-grained abrasive paper. No chamfers must be ground!
21. Measure length of cover straps and select timber for cover straps in the timber yard.	Number of cover straps has been counted on site.
22. Transport the timber to the work bench and store it.	Ensure freedom of movement.
23. Put template successively on the timber for the cover straps to be produced and scribe cover straps.	Scribe cover straps on one side only. Place upper edges of template and cover strap flush with each other!
24. Saw out the cover straps.	Saw the curve exactly on the band saw! Observe the safety regulations for work on

25. Plane the visible sides of the cover strap foot.

26. Smooth curve with abrasive paper.

27. Store cover straps for transportation.

the band saw!

Use a hand plane.
Just smooth-plane, remove small chip.

Use coarse-grained abrasive paper.

Store cover straps so that they cannot be
damaged or get dirty.

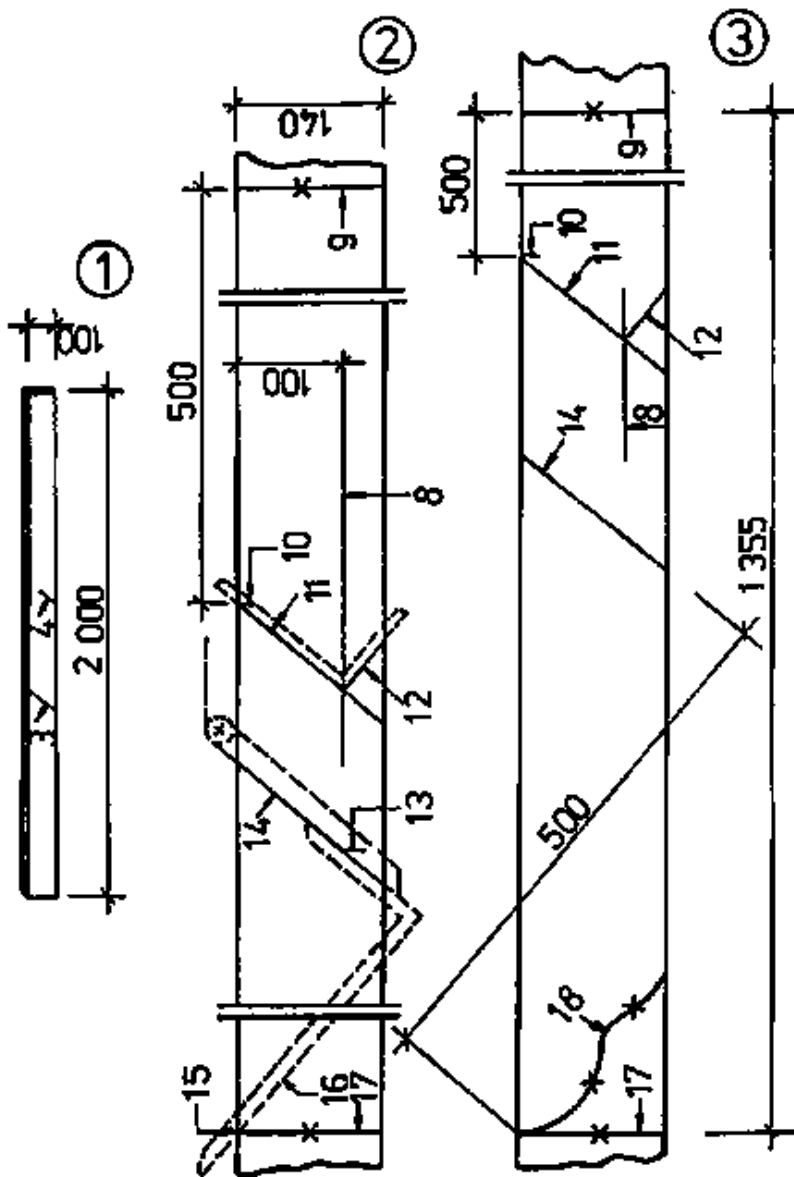

			3.4.
IBE	Re-proofing of Buildings		3603

Re-proofing of Buildings

